

# COMPUTER DESIGN

THE DESIGN AND APPLICATION OF DIGITAL CIRCUITS, EQUIPMENT & SYSTEMS

OCTOBER 1965



22275  
460650  
0502  
F236889  
H. H. GANNON - ENG  
BOEING  
1115 10TH ST  
SEATTLE WASH 98107

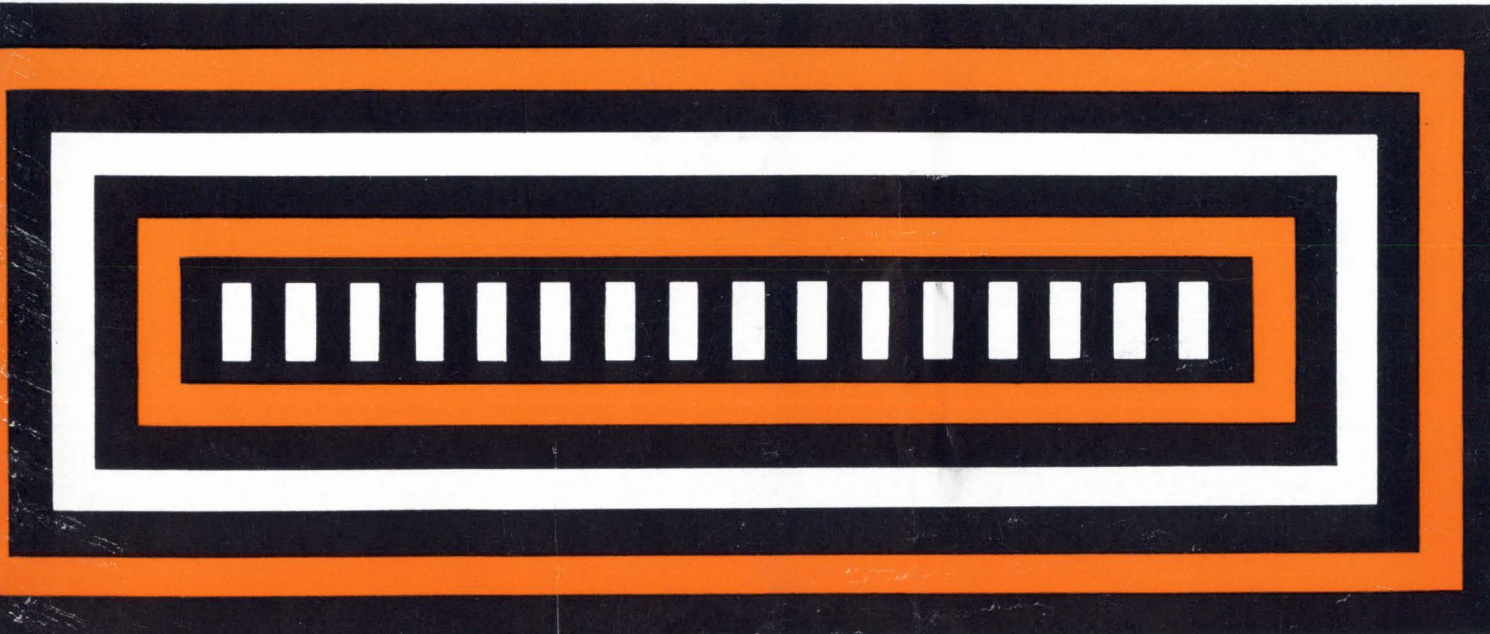

in this issue • Product Reference File: CARD / TAPE CONVERTERS

# NEW



## INTEGRATED CIRCUIT 1 $\mu$ SEC CORE MEMORY

New ICM-40 microcircuit, coincident current, random access core memories feature full cycle operation in 1  $\mu$ SEC (less than 500 nsec access time). ICM-40s feature price, size and reliability advantages of integrated circuit  $\mu$ -PAC<sup>™</sup> logic.\* Word capacities to 16,384 in a 5 $\frac{1}{4}$ " high unit for mounting in a standard relay rack. Design permits pull out front of rack access. Operating temperatures from 0°C to +50°C, with broad margins. Clear/Write, Read/Restore and Read/Modify/Write are standard modes of operation. ICM-40 interfaces comfortably with both discrete component and integrated circuit systems. Low power dissipation.

\*More than 20 months of in-house funded research went into development of the standard  $\mu$ -PAC line of 5 mc silicon monolithic integrated circuit modules.

3C SALES OFFICES: NEEDHAM, MASS.; FOREST HILLS, N.Y.;  
LEVITOWN, PA.; SYRACUSE, N.Y.; SILVER SPRING, MD.; HOUSTON,  
TEXAS; HUNTSVILLE, ALA.; ORLANDO, FLA.; DES PLAINES, ILL.;  
DETROIT, MICH.; CENTERVILLE, OHIO; LOS ANGELES, CALIF.;  
PALO ALTO, CALIF.; KENT, WASH.; ALBUQUERQUE, N.M.



**COMPUTER CONTROL COMPANY, INC.**  
OLD CONNECTICUT PATH, FRAMINGHAM, MASSACHUSETTS 01702

CIRCLE NO. 1 ON INQUIRY CARD

# Integrated circuit digital modules with the highest guaranteed noise rejection: 1.5 volts on clock lines, 30 volts on data lines.

## And that's not just a lot of noise from Raytheon Computer.

Why buy integrated circuit modules with inadequate protection against noise? Now, Raytheon Computer offers IC digital modules that are virtually impervious to system noise. These new ICs give you 1.5 volts guaranteed rejection on clock lines, 30 volts on data lines. And buffering provides 3 volt rejection on all outputs.

The new IC modules operate at 200KC and are compatible with the more than 100 existing Raytheon Computer discrete component digital modules for 200KC, 1MC, 5MC and 20MC frequencies. This means you can buy our lower-priced 200KC IC modules and not give up high frequency capability.

Raytheon IC modules are on the same compact 3¾ inch x 4¼ inch 35-pin boards as the discrete units and have compatible logic levels and power requirements. IC flatpacks are mounted with parallel gap soldering resulting in smaller, stronger joints which make encapsulation unnecessary. Logic density is as high as 24 flip-flops per board.

Write today for additional information. Ask for Data File M-115B. Raytheon Computer, 2700 South Fairview Street, Santa Ana, California.

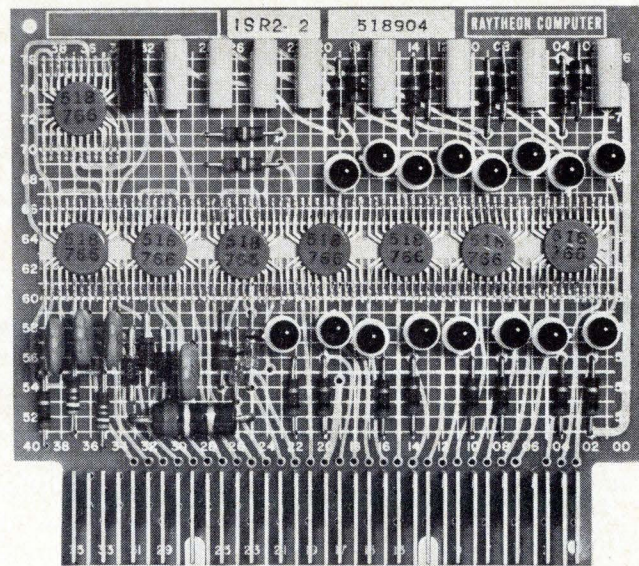

#### THESE NINE CIRCUITS AVAILABLE NOW

IDC1: Decade counter with one digit decoder and 10 line output. IFF1: Flip-flop 4 circuits universal. IFF2: Flip-flop, 12 circuits, buffer storage, parallel in, parallel out. ISR1: Shift Register, 8 bit and 4 bit, Serial in, Serial or Parallel out, T & F out of each Flip-flop. ISR2: Shift Register, 16 bit, Parallel in or Serial in, Serial out, Parallel out for last 8 bits. ISR3: Shift Register, two 4 bit, Serial or Parallel in, Serial or Parallel out, T & F out of each FF. ISR4: Shift Register, two 14 bit, Reg. A Serial or Parallel in, Serial out, Reg. B Serial in or Parallel transfer from Reg. A, Serial out. ISR5: Shift Register, two 12 bit, Reg. A Serial or Parallel in, Serial out, Reg. B Serial in or Parallel transfer from Reg. A, Serial out. IUC1: Universal Counter, 2 decimal digits or two 4 bit binary counters, parallel preset input.



# We don't claim that Royal Paper Tape equipment is more reliable.

## Our customers do.

And you can get their names from our representative.

What we do is tailor 50 CPS and 75 CPS punches and readers to their specifications and help integrate them into their system (rack mounted, desk mounted or custom-designed units). Give a meaningful warranty we stand behind. Guarantee fast service. And provide these new design features for greater efficiency and reliability:

- Efficient electromagnets and off-center springs insure smooth, trouble-free punching.
- Reluctance type pickup for timing eliminates contacts and cams, reduces systems noise.
- Bi-directional reader operates with high reliability at low noise level through action of sensing pins on wire contacts and strobe-like interrogate pin.
- Sealed read station protects mechanism . . . saves maintenance.
- Semiautomatic feed allows fast tape loading (operator merely places tape in head assembly throat).

All at no extra cost. Evaluate them for yourself before you go a step further on *any* system requiring a punch or reader mechanism. There is a Royal Series 500 (50 CPS) and a Royal Series 700 (75 CPS) unit for every punched tape requirement. Including, most specifically, *yours*. Write for specifications. Industrial Products, Royal Typewriter Company, A Division of Litton Industries, Dept. 35JV, 150 New Park Avenue, Hartford, Conn.

*Series 500 and 700 Integrated Punch Stations can operate as a complete tape punching facility when cable connected to appropriate signal generating equipment. This configuration includes a standard 8" tape supply reel in a drawer mounted at the base of the unit. The tape feeds through the punching head and a tape guide (located at the rear) to a side mounted take up reel. Take up reels in either 7½" or 8½" diameters are available. The over-size chad container can accommodate chad from approximately 1000 feet of punched tape. Overall dimensions are 13½" wide x 15" deep x 9½" high. Weight is approximately 23½ lbs.*



**ROYAL** 

CIRCLE NO. 3 ON INQUIRY CARD

# COMPUTER DESIGN

FOR ENGINEERING PERSONNEL RESPONSIBLE FOR THE DESIGN & APPLICATION OF DIGITAL CIRCUITS, EQUIPMENT, AND SYSTEMS IN COMPUTING, DATA PROCESSING, CONTROL AND COMMUNICATIONS.

ROBERT BROTHERSTON, Publisher  
S. HENRY SACKS, Editor

**Editorial Advisory Board**

HAROLD H. SEWARD  
JOSEPH D. SABO  
EDWARD M. COPPS, JR.  
DANIEL J. LICKLY

**Contributing Editors**

RICHARD AHRONS  
DAN M. BOWERS  
A. S. BUCHMAN  
W. A. GANNON  
WALTER A. LEVY  
H. S. MIILLER  
RICHARD PETERSEN

**Washington Editor**

HAROLD V. SEMLING, JR.

JAMES FLORA                      Art Director  
THERESA SACKS                  Production Manager  
BERNARD GREENSIDE            Tech. Illus.  
JERILYN DEE                      Editorial Ass't.  
SANDRA M. MARTIN              Adv. Prod.

LINDSAY H. CALDWELL  
Vice Pres.-Sales

**Editorial & Executive Offices**  
Professional Bldg.

Baker Ave.                      •                      W. Concord, Mass.  
Tel. 369-6660

Computer Design is published monthly. Copyright 1965 by Computer Design Publishing Corporation. Accepted as controlled circulation publication at Post Office at Boston, Massachusetts. No material may be reprinted without permission. Postmaster: CHANGE OF ADDRESS — FORM 3579 to be sent to Computer Design, Circulation Dept., P. O. Box B, Arlington, Mass. 02174. Subscription rate to non-qualified subscribers is \$15.00 per year; \$1.50 per issue. Subscription rate to all foreign subscribers is \$25.00 per year; \$2.50 per copy.



Circulation  
over 24,000

**FEATURES**

**8 CD READERS' FORUM**

Continuing the campaign to establish a universal logic symbology standard, CD Readers' Forum describes the standard adopted by IBM for its System 360.

**CD PRODUCT REFERENCE FILE**

**24 CARD/TAPE CONVERTERS**

A brief survey of commercially-available card/tape converters. A summary of the performance characteristics of manufacturers' units is included.

**32 DESIGN GUIDE FOR COMPUTER-COMMUNICATIONS SYSTEMS**

Part 4 — Program Design-Functional Considerations

The four major functional aspects of the overall program structure of typical real-time systems are discussed in the 4th part of this series.

**40 CONTROL SYSTEM FOR HIGH-SPEED PHOTOCOMPOSITION**

With emphasis on a unique combination of digital techniques, the system and hardware approach to the design of a photo-typesetting control unit is described.

**52 PROGRAM SWITCH/MATRIX BOARDS**

Brief review of how programming boards function, their advantages, and examples of a matrix board system of programming machine tool operations.

**DEPARTMENTS**

**7 DC OUTPUT**

**14 INDUSTRY NEWS**

**56 NEW PRODUCTS**

• Circuit Components • Circuit Packaging • Input-Output Equipment  
• Console Equipment • Power Supplies • Memories • Test Equipment  
• Systems • Circuit Modules

**74 LITERATURE**

**80 ADVERTISERS' INDEX**

Reader subscription cards ..... opposite page 8  
Reader inquiry cards ..... opposite page 72



# New Plug-in Package Gives You Fast,

Four new families of industrial integrated circuits — Series 70, 73, 74, and 1580 — are now available from Texas Instruments in an advance-design plug-in flat package for reduced equipment-assembly costs. The 28 new circuit types offered in this package provide low cost per logic function, and are designed for operation in a wide range of industrial environments.

The first in a series of modular plug-in packages is a 16-pin version, useful for multi-function logic networks of up to six circuits. Here are features: (numbers refer to cut-away illustration at left)

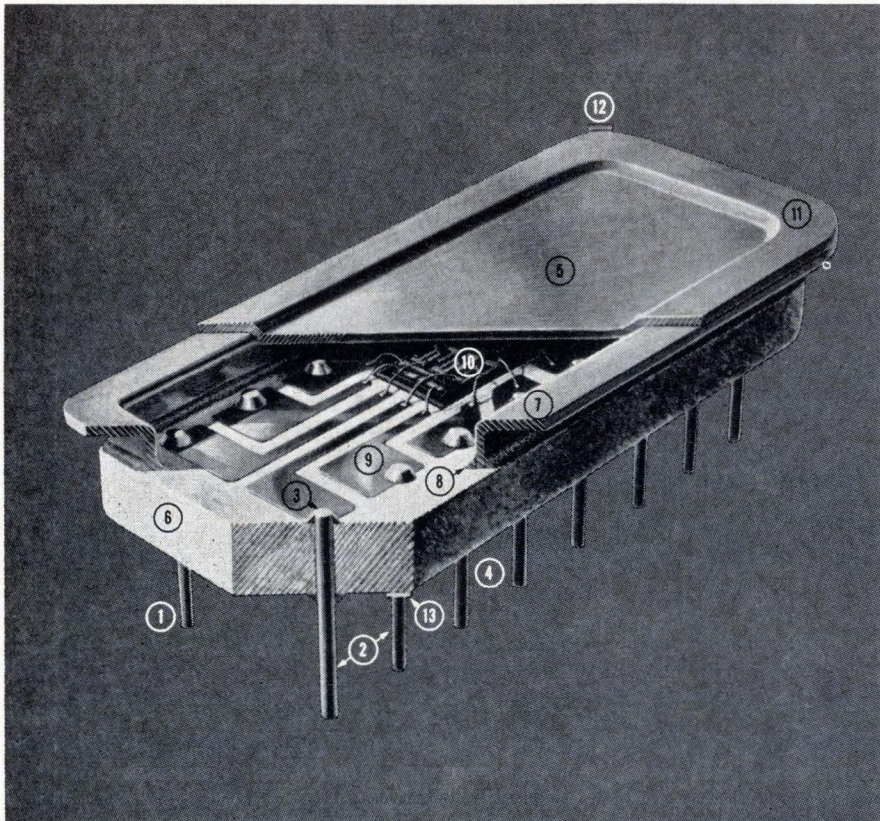

Construction features of TI's new 16-pin plug-in flat pack.

**1. Sixteen pins** enable you to obtain maximum economies inherent in today's multi-function integrated circuits. Pins are in two rows of eight, with rows a convenient 200 mils apart. Positive alignment of pins is assured for high-speed automatic or manual insertion techniques. Alignment tolerance is  $\pm 10$  mils at end of pins.

**2. Pin spacing on 100-mil centers** is appropriate for fast, economical flow- and wave-soldering techniques and for wire-wrap connections.

**3. Round-pin cross-section** is full 20-mil diameter ( $\pm 2$  mils) for strength and rigidity. Pin diameter is compatible with standard PC-board drill fixtures. Pin length is 150 mils, leaving ample soldering space under  $\frac{1}{8}$ " PC board. Despite their rigidity, pins are not brittle, will withstand at least four 90-degree bends using a one-lb weight — exceeding TO-5 requirements.

**4. Pins beneath package** provide maximum rigidity, prevent electrical contact between pins of adjacent packages. With pins projecting from the bottom, additional rows of pins can be added while maintaining same modular length and same form-factor.

**5. Package size—390 by 890 mils**—is convenient for handling during test and assembly. Packages can be mounted at maximum density on 400-mil centers, side-by-side, and 900-mil centers, end-to-end.

**6. Aluminum-oxide ceramic substrate** provides strength and good thermal-dissipation properties. Also provides electrical isolation, pin-to-pin and pin-to-package.

**7. Rugged, flanged sides** provide easy-grip handling without touching pins.

**8. Brazed ceramic-to-metal seal** assures that package will withstand external helium pressure of 100 psi with hermeticity of  $50 \times 10^{-8}$  cc/sec. Also withstands thermal shock — cycling between  $-55^\circ$  and  $+300^\circ\text{C}$ , and cycling between boiling water and ice water. More than 3,000,000 similar ceramic-to-

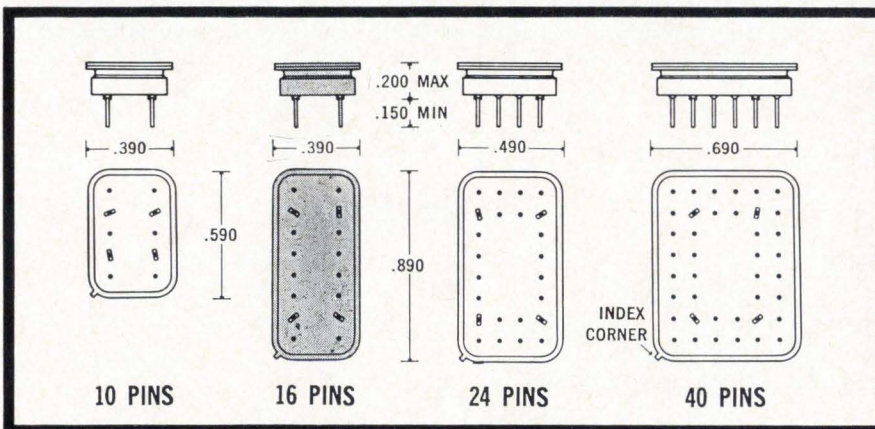

Modular family of plug-in flat packs. First available is 16-pin version.

# For TI Integrated Circuits

## Low-Cost Assembly

metal seals have been applied to TI's TO-50 packages produced for Minuteman and other programs over the past four years.

**9. Metallization pattern** on face of ceramic makes possible short, reliable bonds to the integrated-circuit bar.

**10. Integrated-circuit bar** is recessed in a well, resulting in straight-line bonds to raised bonding pads, with no sags or loops.

**11. Metal lid** is securely sealed with transistor-type "one-shot" resistance weld. Fast, reliable weld means an economical package.

**12. Flange tab** at corner of package provides indexing at a glance.

**13. Stand-off**, 45 mils high, allows easy clean-out of flux beneath package, assures good solder contact through PC-board holes.

A major feature of TI's plug-in package is its modular approach, including versions with 10, 16, 24, and 40 pins. See dimensions at lower left. The larger packages are designed to accommodate the more complex logic arrays to be seen in coming months.

### 28 New Industrial Integrated Circuits Offer Low Cost per Logic Function

TI's new industrial logic families include eight Series 74 TTL networks, 13 Series 73 modified-DTL units, two Series 70 ECL gates, and eight Series 1580 DTL circuits.

Typical gate characteristics for each of the four logic families are listed in the table at right. All these circuits, except Series 70, are reduced-temperature ( $0^{\circ}$  to  $+70^{\circ}\text{C}$ ) versions of established military integrated-circuit lines. They feature the same high performance, same high reliability, and same multi-function economies.

By fabricating two, three, and four circuits simultaneously in a single silicon bar, the cost-per-circuit-function is drastically reduced. Reductions are also obtained in the number of circuit packages, interconnections, and circuit boards — and in inventories, testing, and handling.

The new 16-pin plug-in flat pack is an option available at no additional cost, and is available for Series 70, 74, 1580, and most units in Series 73. The standard package for all four series is the 5-year-proved  $\frac{1}{4}$ " by  $\frac{1}{8}$ " flat pack.

For additional information on TI's industrial logic circuits and the new plug-in packages, contact your local TI Sales Engineer or circle No. 25 on the Reader Service Card.

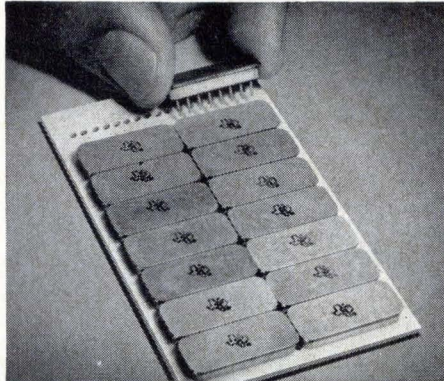

Plug-in flat packs shown mounted at maximum density. Units are easily handled and inserted through PC board.

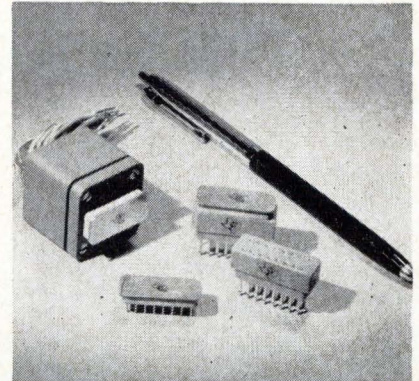

Production test socket (left) and breadboarding sockets (right) are being developed for plug-in flat packs.

#### TYPICAL GATE CHARACTERISTICS OF TI'S INDUSTRIAL LOGIC FAMILIES

Parameter	Series 73	Series 74	Series 70	Series 1580
Propagation delay, nsec	30	13	5	25
Power dissipation, mw	10	10	40+	5
Fan-out	10	10	N/A	8
Noise immunity, mv	300	1000	250	750
Supply voltage, v	3 to 4	4.75 to 5.25	+1.25, -3.5	4.5 to 5.5
Temperature range, $^{\circ}\text{C}$	$0^{\circ}$ to $+70^{\circ}$	$0^{\circ}$ to $+70^{\circ}$	$0^{\circ}$ to $+70^{\circ}$	$0^{\circ}$ to $+70^{\circ}$

#### TYPES AVAILABLE IN TI'S INDUSTRIAL LOGIC FAMILIES

	Series 73 Modified-DTL NAND/NOR	Series 74 TTL NAND	Series 70 ECL OR/NOR	Series 1580 DTL NAND
J-K Flip-flop	SN7300 SN7301	SN7470		SN1590 SN1591 SN1593
Dual J-K Flip-flop	SN7302 SN7304			
Quad gate	SN7360	SN7400		SN1583
Triple gate	SN7331	SN7410		
Dual gate	SN7311 SN7330	SN7420 SN7440	SN7000 SN7001	SN1581 SN1584
Single gate	SN7310	SN7430		
Dual EXCLUSIVE-OR	SN7370	SN7450		
Expander	SN7320	SN7460		SN1580
Inverter, Buffer	SN7350			SN1582
"One Shot"	SN7380			



**TEXAS INSTRUMENTS**  
INCORPORATED  
13500 N. CENTRAL EXPRESSWAY  
P. O. BOX 5012 • DALLAS 22, TEXAS

# Contemporary Electronics is one of the largest producers of computer pulse transformers in the U.S.

## SO?

So, maybe you're missing a bet if you haven't checked Contemporary Electronics for *quality, service* and *price*.

Contemporary Electronics *specializes* in pulse transformers. It's not a sideline, but a principal part of our business. Well over 100,000 pulse transformers are produced each month in 75 different designs.

**Advantages? Here are some.**

**Technical Capability.** Contemporary Electronics engineering staff knows computers and can design any special product for any application.

**High Quality.** Most transformers have special high quality design features. All pulse transformers are 100% inspected as many as three times before shipment. QC system meets MIL-Q-9858, and has been approved for use on the Apollo program.

**Fast Sample Service.** Samples, small production lots and specials are normally shipped 24 to 72 hours after receipt of request.

Interested in what can be done in terms of performance, size, delivery, or MIL-specs? Get to us—we've got lots more to tell.

WRITE, OR CALL COLLECT AND WE'LL HAVE THE FULL STORY TO YOU WITHIN 48 HOURS



 **CONTEMPORARY  
ELECTRONICS**

128 North Jackson, Hopkins, Minn. 55343 Telephone 935-8481—Area Code 612  
**EXTRA SERVICE TO THE DATA PROCESSING INDUSTRY**

CIRCLE NO. 4. ON INQUIRY CARD





Computers will not increase concentration in industry. Walter W. Finke, President of Honeywell EDP, recently told the Senate Antitrust and Monopoly Subcommittee. The relative computing power available to small business is equal to or greater than that available to large business, Finke told the Senators. The capability to make full use of that equipment is available in equal measure, he said, and Honeywell's experience in recent years has indicated a very strong trend towards increased small business usage of the computer.

Senator Philip A. Hart (D. Mich.), Subcommittee Chairman, is holding a series of hearings on economic concentration in industry. Some economists, according to Hart, "have indicated concern that the introduction and use of the computer will have the effect of bringing about further increases in concentration. This line of reasoning is based upon the assumption that only the very large firms can afford to install and use computers and related equipment."

Finke expressed doubt as to the basic assumption of the economists mentioned by Senator Hart. He said small businesses, "by using the computer wisely, will continue to be a major competitive force in our free enterprise system."

Congress has been urged to adopt a computer data plan by the American Institute of Certified Public Accountants. Karney A. Brasfield, Chairman of the group's government relations committee, in an appearance before a Joint Congressional Committee, stressed the need for Congress to sharpen its tools.

CPA's suggested that Congress could use an information system to gather, classify, analyze, and edit data needed for its decisions through the use of computers. "An effective use of data processing techniques makes it practical to be more selective, more penetrating, and more current than was ever possible."

An investigation by the General Accounting Office of selected aspects of the Federal Aviation Agency's purchase of certain ADP equipment at its New York Air Route Traffic Control Center indicated that additional costs of about \$147,000 were incurred "because the agency failed to provide purchase options."

In reply to GAO, FAA's Administrator agreed they should have made a more timely study of the methods

of acquiring ADP equipment and should have provided for appropriate purchase options.

Modern computer technology is being applied to the Government's emergency planning efforts. Office of Emergency Planning Director Buford Ellington told a group recently that OEP has highly-developed electronic computers, a trained staff to operate them, and massive data libraries in which are stored more than a billion bits of information — 750,000 resources records — packed into "man-made brains that can circulate faster and more accurately than any army."

#### Recent Defense Department Contracts.....

**PHILCO CORP.**, Willow Grove, Pa., awarded a \$1,692,384 fixed-price order for electronic data processing systems. The Directorate for Procurement 2750th Air Base Wing (Air Force Logistics Command), Wright-Patterson AFB, Dayton, Ohio, issued the contract order.

**SPERRY RAND CORP.**, St. Paul, Minn., received a \$1,000,000 increment to a previously-awarded contract for the development of digital computers for airborne guidance systems. The Ballistic Systems Division (AFSC) is the contracting agency.

**C-E-I-R, INC.**, Washington, D.C., has been awarded a contract extension by the Aerospace Research Laboratory, Wright-Patterson Air Force Base, Dayton, Ohio, for its continuing investigation into the use of mathematical computer programming techniques for the calculation of atomic wave functions.

**SYLVANIA ELECTRIC PRODUCTS, INC.**, Mt. View, Cal., awarded a \$3,251,701 fixed-price order for spare parts for EDP equipment. The contract order is from the Warner Robins Air Material Area (Air Force Logistics Command), Robins AFB, Ga.

**UNIVAC DIVISION**, Sperry Rand Corp., Washington, D.C., was issued a \$6,705,610 fixed-price contract for EDP systems. Work will be done at Philadelphia, Pa. The 2750th Air Base Wing, Wright-Patterson AFB, is the contracting agency. The **UNIVAC DIVISION** at St. Paul, Minn., also received a \$2,710,240 negotiated fixed-price contract for computer digital data sets, associated equipment and engineering services, for installation on Naval Tactical Data System equipment on Naval Ships and at shore installations. Bur. of Ships awarded contract.



## SALES OFFICES

### BOSTON

Lindsay H. Caldwell  
Professional Bldg.  
Baker Ave.  
W. Concord, Mass.  
phone: (617) 369-6660

### NEW YORK

Robert J. Bandini  
663 Fifth Ave.  
New York 20, N. Y.  
phone: (212) 421-4840

### CHICAGO

Phil Holmes  
410 N. Michigan Avenue  
Chicago 11, Illinois  
phone: (312) 467-6240

### DETROIT

Robert T. Barrett  
424 Lafayette Building  
Detroit 26, Michigan  
phone: (313) WO 1-0278

### LOS ANGELES

David Barton  
672 So. Lafayette Park Pl.  
Los Angeles 57, California  
phone: (213) 382-1121

### LONG ISLAND — SO. CONN.

C. Lynn Coy  
Robert C. Woodies  
155 E. 50th St.  
N.Y., N.Y. 10022  
phone: (212) 751-2960

### SAN FRANCISCO

David Barton  
672 So. Lafayette Park Pl.  
Los Angeles 57, California  
phone: (213) 382-1121

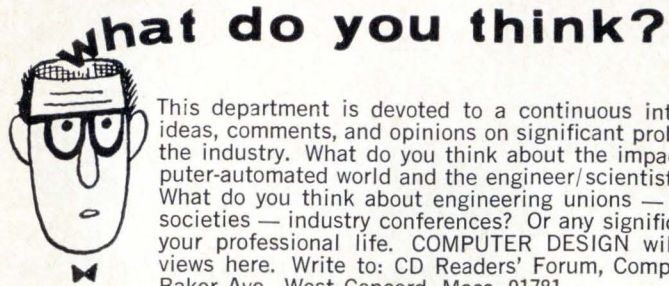

This department is devoted to a continuous interchange of ideas, comments, and opinions on significant problems facing the industry. What do you think about the impact of a computer-automated world and the engineer/scientist's role in it? What do you think about engineering unions — professional societies — industry conferences? Or any significant facet of your professional life. COMPUTER DESIGN will print your views here. Write to: CD Readers' Forum, Computer Design, Baker Ave., West Concord, Mass. 01781.

## CD READERS' FORUM

### LOGIC DIAGRAM SYMBOLS IN THE IBM SYSTEM/360

**R. C. BODEN,**

Poughkeepsie Laboratory,  
IBM Corp.

In the development of the maintenance philosophy and plans for the System/360, IBM management agreed at the outset that logic documentation must follow the same symbology throughout the entire range of equipment. They also decided to break with the past and employ new concepts in logic symbology wherever these would be in the interest of long term maintainability improvement. A study of the ASA Y32.14 standard led to a de-

cision to use that document as the basis for the development of a comprehensive, fully detailed working standard for logic symbology throughout the IBM Corp. It was further decided, after close examination of the two different sets of symbols provided in the ASA standard, that the uniform shape set was preferable.

Rectangular blocks with internal mnemonic labeling are easier to handle for various drafting and presentation techniques. They are easily recognizable, easily recalled, and lend themselves to compact diagram structure. They are especially suited to the requirements of automation in the production of machine printed diagrams. Logic symbols in the IBM Standard, therefore, would consist of a set of rectangles each of which is internally labeled to show function.

In the ASA Standard as well as in the IBM Standard derived from it, the emphasis is on utility by the man who services the equipment. Although the symbology bears a definite relationship to Boolean algebra, the IBM Customer Engineer (CE) is not required to be proficient in that branch of mathematics in

**EDITOR'S NOTE:** In our campaign to establish a logic symbology standard that can be generally accepted throughout the industry, COMPUTER DESIGN hopes to present all reasonably-held views. This month we are pleased to present extracts from a description of the standard adopted by IBM for its System/360. These symbols are based on the ASA Y32.14 standard. The author, Mr. Boden, was a member of the group that developed this standard.

Logic Block Symbols for Logic Diagrams (A Summary of Typical Features)

BASIC BLOCKS

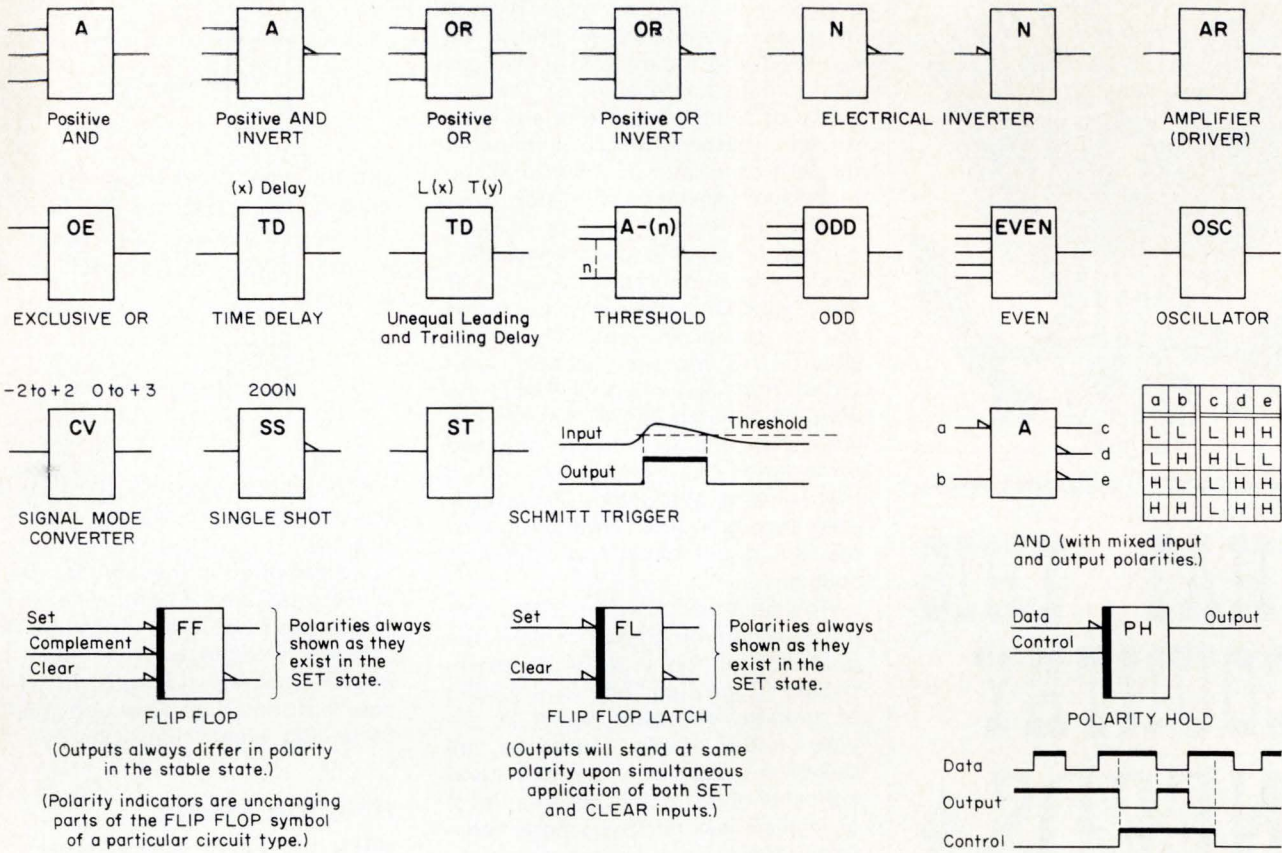

COMPONENT AND AUXILIARY BLOCKS

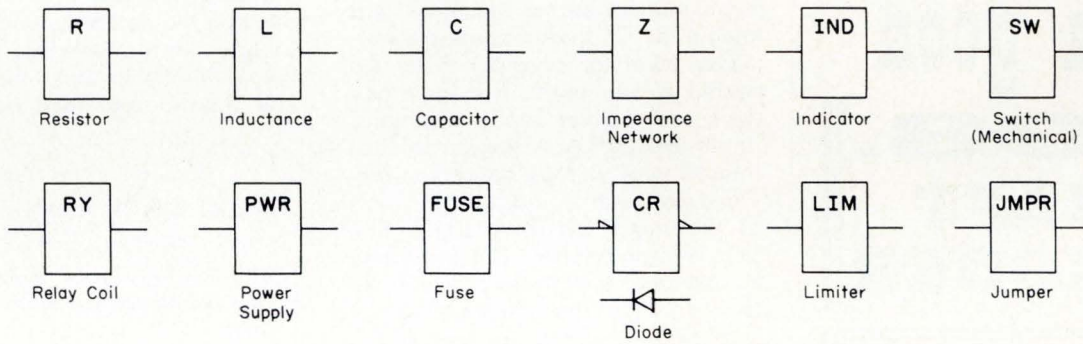

LINE SYMBOLS (Pertaining to Blocks)

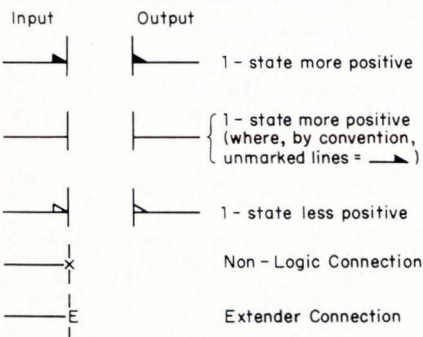

Note: Applicable Input and Output polarities must be shown at all logic blocks.

BLOCK BUTTING

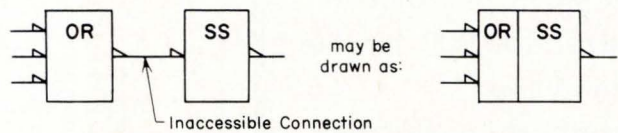

The DOT OR and DOT AND

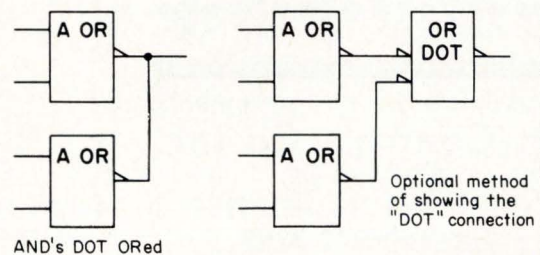



**WHAT THIS  
COUNTRY  
NEEDS**  
is a good  
[ **\$98.** ]  
**SHAFT  
ENCODER**

- up to 2048 bits/rev.
- 2 3/8 inch diameter
- over 100,000 bits/sec.
- long life
- rugged construction



Let us know your requirements:  
**HH Controls Co. Inc.**  
69 Pearl St.,  
Cambridge, Mass. 02139  
Tel. (617) 272-3298

CIRCLE NO. 5 ON INQUIRY CARD  
10

order to read and understand his logic diagrams.

The IBM Standard also states, as a basic rule, that a logic diagram must be constructed so that a CE can read and understand it without an intimate knowledge of the circuitry of which the blocks are comprised. The replaceable element in modern computers is seldom at the individual resistor or transistor level. The CE replaces a card or module on the basis of a diagnostic technique which operates in terms of logic function. He generally need not be concerned with the actual circuit or component details, provided that the block symbols he uses in detailed logic analysis can convey by themselves the required information. Experience has shown that such a symbology is achievable throughout a wide range of modern circuit types and operating speeds.

The CE must know, in addition to the function being performed, the polarities of the logic voltages involved in the function. In a system of voltage operated two-state devices under stable conditions, all points in a logic network will stand either at their more positive level or at their less positive (more negative) level. Knowledge of the relationship between function of a logic block and the signal voltage levels which operate the block will enable the CE to determine the particular level (or polarity) to be expected at any point in a logic network under given input conditions. In the IBM and ASA Standards, such indication of voltage polarity is provided by polarity indicator symbols at the point where a signal line joins a logic symbol. It is important to note that a polarity indicator refers only to the particular block symbol with which the indicator is in contact.

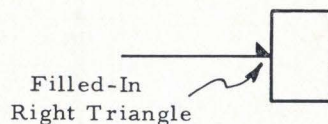

Block function refers to the more positive level of this input lead.

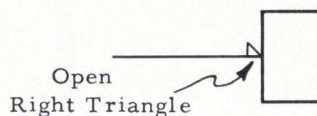

Block function refers to the less positive (more negative) level of this input lead.

The output 1-state (true) of the following block, with respect to the function



and the input polarities shown, is the *more positive* level on this lead.

The output 1-state (true) of the following block, with respect to the function

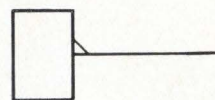

and the input polarities shown, is the *less positive (more negative)* level on this lead.

As provided in the ASA Standard, a user may elect to omit one of the two types of polarity indicators (the filled-in triangle or the open triangle) from his diagrams, in which case all unmarked lines are treated as having a particular polarity.

**FUNCTION SYMBOL  
WITH POLARITY INDICATION**

Sample logic block configurations are shown below in order to demonstrate the flexibility and simplicity inherent in the Standard as regards the relationship between function and input-output lead polarities.

Table of Combinations:

(H refers to the more positive of the two possible levels, L to the less positive)

Input		Output
A	B	C
L	L	L
L	H	H
H	L	H
H	H	H

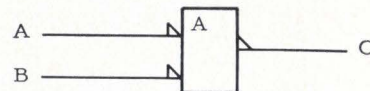

The above logic block may be read as follows: when and only when lines A and B are both stand-

# DATA COMMUNICATIONS

equipment for on-line,  
real-time processing

## picking paper tape punches and readers

The integration of paper tape punches and readers within data processing systems has been widespread. Paper tape has become an important communications link, and

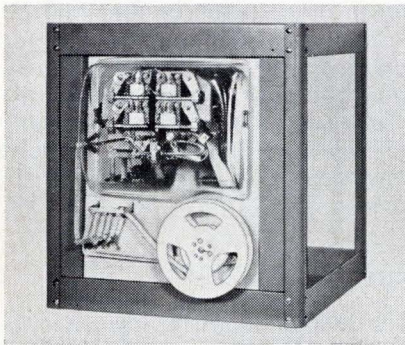

DRPE PAPER TAPE PUNCH

is still the most inexpensive and reliable continuous recording medium available.

### OFFERS FLEXIBILITY IN COMMUNICATIONS

Teletype paper tape punches offer a variety of data communications uses. They can be used on the receiving end of high-speed tape-to-tape systems. They can combine data from various sources on one master tape. Some units include a printing mechanism for simultaneous punch and print information.

There are punches available to operate at 6 to 240 characters per second (60 to 2,400 words per minute), and for punching fully perforated or chadless tape.

Most Teletype paper tape units are available in 5, 6, 7, or 8-level, and either as self-contained units or as components in other Teletype equipment, such as automatic send-receive sets.

Teletype LARP Tape Punch—A multi-magnet punch designed to serve as a "slave" unit for a variety of data

processing systems. Operates on a parallel-wire basis at 20 cps (200 wpm) or less.

Teletype LPR Tape Punches—Actuated by incoming serial line signals, these self-contained units operate at 10 cps (100 wpm). They also have a printing mechanism to print out information that is simultaneously punched in the tape.

Teletype BRPE Tape Punch—This high-speed parallel-wire punch operates at 105 cps (1,050 wpm). It can record output of computers and other business machines, as well as produce master tapes by combining information from various sources.

Teletype DRPE Tape Punch—In this unit, instead of a motor, an electro-mechanical punch supplies the energy to perforate data into paper tape. Operates at speeds up to 200 cps (2,000 wpm). The unit is asynchronous and needs no adjustments or modifications when changing speeds.

### FAST, ACCURATE DATA TRANSMISSION

Teletype tape readers are available to operate at speeds of 6 to 240 cps (60 to 2,400 wpm). They are designed for fast, accurate, and dependable data transmission, whether your needs involve simple station-to-station relay or the more complex transmission requirements of data processing. Most Teletype tape readers will handle fully perforated or chadless tape.

Teletype LX Tape Readers—These units convert data from punched paper tape into parallel-wire impulses. Speed may be varied from 6 to 20 cps (60 to 200 wpm) by substituting different drive gears.

Teletype LXD Tape Readers—Transmit a serial signal at 10 cps (100 wpm). Provide dependable, economical transmission of messages and data.

Teletype CX Tape Reader—Data collected from slower machines can be transmitted over this unit at 105 cps (1,050 wpm). It transmits parallel-wire signals, and can be used as an input device for computer and business machines, feeding synchronized data instantly into these systems.

Teletype DX Tape Reader—Transmits parallel-wire binary signals at speeds up to 240 cps (2,400 wpm). The DX is equipped with step-by-step feeding that enables it to start and stop on a single discrete character with no coasting.

The variety and reliability of Teletype paper tape punches and readers is another reason why they're made for the Bell System and others who require dependable communications at the lowest possible cost. For further information write to: Teletype Corporation, Dept. 71K, 5555 Touhy Avenue, Skokie, Illinois 60078.

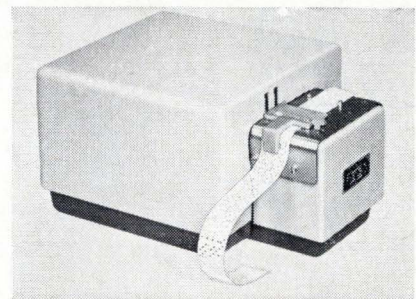

DX PAPER TAPE READER

*machines that make data move*

CIRCLE NO. 6 ON INQUIRY CARD



ing at their less positive level will the output lead C stand at its less positive level. The function of the block is AND.

Table of Combinations:

Input			Output
A	B	C	D
L	L	L	H
L	L	H	H
L	H	L	H
L	H	H	L
H	L	L	H
H	L	H	H
H	H	L	H
H	H	H	H

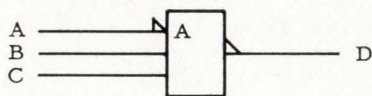

The above logic block may be read as follows: when and only when lines B and C are both standing at their more positive level and line A is standing at its less positive level will the output line D stand at its less positive level. The function of the block is AND.

Table of Combinations:

Input			Output
A	B	C	
L	L	L	L
L	H	L	L
H	L	L	L
H	H	H	H

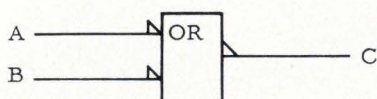

The above logic block may be read as follows: when and only when line A or line B or both stand at their less positive level will the output line C stand at its less positive level. The function of the block is OR.

The OR block shown above may also be diagrammed as an AND block through the change of input and output polarity indicators. In the IBM Standard, as in the ASA Standard, the decision to show a

particular logic circuit as an AND or an OR is left to the discretion of the logic designer.

In the language of Boolean algebra, such duality is explained in terms of which voltage level is to be considered as representative of the Boolean 1 (or truth). In effect, the polarity indicator at a block only shows which voltage level is to be considered the Boolean 1 **with respect to that block**. The CE need not concern himself with this kind of derivation nor with the method by which the logic is developed. He is interested primarily in questions such as: "What kind of operation does this block perform?" and "What are the polarities and test point locations of the leads involved?" A careful following of the Standard will provide a rigorous relationship between voltage level and function throughout the logic diagrams of an entire computer system.

#### GROUND RULES

It is appropriate to discuss certain of the more important ground rules which pertain to all of the blocks. These rules are taken from the IBM Standard but have their derivation, where possible, in the ASA Y32.14 document.

1. Neither size nor aspect ratio of a block affects its function as internally labeled.
2. A block may be expanded in size, if necessary, to accommodate additional inputs or outputs.
3. A logic block may have more than one logic output lead, provided that each of these, **with polarity as indicated**, is the **same** function of the block as shown.
4. A non-logic connection to a block (e.g., a bias lead, a return lead, a shield lead, or a special voltage line) must be marked by an X at the place which would normally be occupied by the polarity indicator.

5. In the case where a circuit is used to add inputs to another AND or OR circuit, and the connection from this second circuit to the first is made at other than a normal input or output of the first circuit, the connection shall be shown without polarity and labeled E (for EXTENDER). In the IBM Standard, the E is placed at the block whose inputs are being extended. The extender block must be labeled with the same function as the block being extended.

6. No input shall enter a symbol on the output side.

7. Blocks may be butted together to save space and promote diagram clarity wherever: (a) the interconnection between the blocks to be butted does not connect to any other block, and (b) the interconnection does not represent a test point for maintenance purposes, (Accessible pin connections are generally treated as possible test points for the CE in IBM.) and (c) no logic inversion takes place between the blocks.

#### SUMMARY

The IBM Standard for logic symbology in the System/360 includes many implementation and drafting practice details which, while important in the preparation of a good logic diagram, are not actually in the realm of logic symbology itself. No attempt has been made in this article to cover all details of the logic diagramming subject or to include all the variations of symbols that may arise.

In the matter of conformance to the ASA Y32.14 Standard, comparison will show only minor differences — these mainly in the extension of the symbology to cover logic functions or implementation details not considered in the ASA document. On the other hand, certain options and presentation techniques allowable under that standard have not been incorporated, at this time, into the IBM Standard.

---

## ORDER YOUR FJCC DISCUSS-ONLY PAPERS NOW — SEE PAGE 45.

---

# DATA COMMUNICATIONS

equipment for on-line,  
real-time processing

## there's more than that to a page printer!

Is most of your data coded in numbers? Need a page printer that will print in 2-colors? Neither is difficult in data communications, because Teletype page printers offer a wide variety of print-out capabilities.

The Teletype numeric keyboard has keys similar to an office adding machine to provide fast, efficient collection, integration, and transmission of numerically coded data. It can be used by branches to record and transmit numeric data to processing or distribution centers to simplify ordering and inventory control, as well as speed shipping. Though this Teletype set transmits numeric data only, it will receive and print-out all alphanumeric characters.

### TWO-COLOR PRINTING

There are many applications of 2-color printing, including tie-ins with business machines. Accounting and statistical departments can use Teletype machines to transmit data in 2-colors to the home office or a centralized data processing center. For instance, the red can be used to indicate

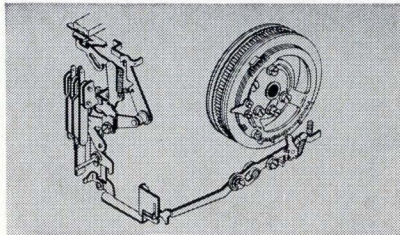

HORIZONTAL TABULATOR

"loss" figures and the black to indicate "profit" figures. Page printers can also be used to report plant operations, using black for normal conditions and red for abnormal conditions.

### AIDS TO DATA COMMUNICATIONS

There are many additional Teletype page printer features that further improve your data communications capabilities. These include: vertical and horizontal tabulators; a variety of type styles and sizes; and sprocket feed platens that enable you to type on multicopy business forms.

There are also a variety of platen widths to accommodate most standard size forms. Another important feature is the automatic forms feed-out. With one key stroke, you can advance a business form, bringing the next one to the starting position automatically.

### KEEPS MANAGEMENT UP-TO-DATE

The capabilities of Teletype page printers have found wide application in both business and industry. For

example, a large aircraft plant uses nearly 50 Teletype Model 35 page printers throughout the plant to report production information to two real-time computers. In this way, management is provided with instant information on the status of plant operations. This system has helped management to tighten control over in-plant functions, shorten production time, and reduce overall manufacturing costs.

And there's more to Teletype equipment than just page printing—such as automatic and keyboard send-receive sets, and a variety of paper tape punches and readers to name only a

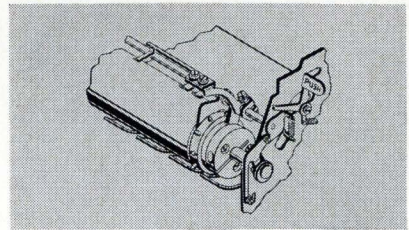

SPROCKET FEED PLATEN

few. That's why these Teletype machines are made for the Bell System and others who need dependable communications at the lowest possible cost. A brochure on the applications of Teletype equipment is available by writing: Teletype Corporation, Dept. 71K, 5555 Touhy Avenue, Skokie, Illinois 60078.

*machines that make data move*

CIRCLE NO. 7 ON INQUIRY CARD



*Absolutely  
Reliable*

**DUE TO  
PLANETGEAR®  
PRINCIPLE!**

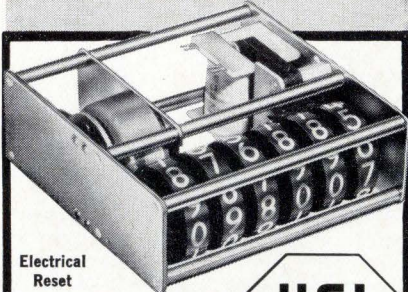

Electrical  
Reset



## Digital CLOCKS and COUNTERS

*Never Slip, Skip or  
Miss a Count!*

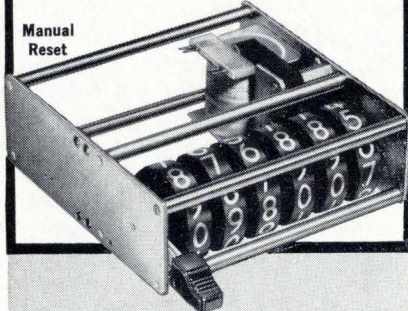

Manual  
Reset

This amazing feat is accomplished because with HSI PLANETGEAR the gears are always in mesh... even while resetting!

You need these trustworthy components if you have applications where there are demands for digital devices which:

- ... offer maximum rapid drum transfer.
- ... give high speed counting (over 2000 RPM).
- ... give infallible accuracy.
- ... long life at high speeds.

HSI has prepared a *gold mine* of scientific and technical data on its PLANETGEAR Pulse Counters and on the revolutionary Digital Stop Clocks and Time Totalizers. Without the slightest obligation write Haydon Switch & Instrument, Inc., 1500 Meriden Road, Waterbury, Conn. 06720 for Bulletins No. 44-1R (Counters) and No. 42-2R (Clocks).



**HAYDON SWITCH &  
INSTRUMENT, INC.**

1500 MERIDEN ROAD  
WATERBURY, CONN. 06720

CIRCLE NO. 8 ON INQUIRY CARD



**INDUSTRY NEWS**

A CONTRACT HAS BEEN RECEIVED BY DATAMARK, INC., FROM NASA, TO BUILD A HIGH-SPEED PRINTER DECODER SYSTEM. The system will record the output from high-speed digital computers in a 132 column format. It includes a new patented vacuum booster system for paper tension which prevents paper jam-up at speeds of 1000 lines per minute. This printer will be a part of the ground systems for NASA on the Orbiting Astronomical Observatory Satellite Program.

THE UTAH POWER AND LIGHT COMPANY HAS RECENTLY ORDERED AN ALL-DIGITAL SYSTEM OPERATION COMPUTER CONTROL SYSTEM from the Westinghouse Power Control Division. It will be used for load frequency control, economic dispatch, economy interchange, load forecasting, data logging and alarming, status monitoring of 72 points, and collection of 39-kw-hr quantities and 38-kw quantities. The equipment for the digital system includes a Prodac 510 digital computer with an 8192-word core memory and a 65,536-word drum memory, operator's and programmer's consoles and high-speed, solid-state digital telemetry and data collection devices. Initially it will control seven generating units at four steam stations, monitor thirteen units at five hydrostations, monitor three nonconforming loads, and monitor twelve interchange points.

"MISSISSIPPI FEDERATED CO-OPERATIVES ARE PUTTING ALL THEIR EGGS IN ONE COMPUTER." The organization, headquartered in Jackson, has ordered a National Cash Register 315 computer and plans to have it in operation by September 1 when the season's first cotton is picked (A "cotton-pickin'" computer?). The system's punched tape input will be produced, variously, by NCR cash registers, accounting machines, and adding machines. The computer's main job will be to keep accurate account of thousands of bales of cotton stored in MFC compresses throughout Mississippi. The system also will handle several other major tasks. It will prepare production and profit reports for a chicken processing plant. The operations of a hatchery and a number of egg grading plants also will be managed by the computer. An analysis is being programmed so the quality of eggs and chickens produced by MFC members can be evaluated and improved. Multiple feed blending mills will create punched paper tape indicating the number of tons mixed, ingredients used and customers who will receive the feed. Thousands of inventory items for five warehouses, now recorded on index cards, will be magnetically maintained on NCR CRAM cards. Data for a new vegetable canning and freezing plant, which covers four acres, will also be processed through the computer. Payroll accounting subsidiaries will also be handled by the system.



# DATA COMMUNICATIONS

equipment for on-line,  
real-time processing

## rock 'em! sock 'em! yea testing!

Reliability is a very important feature of Teletype equipment because it must stand up under all kinds of conditions. That's why laboratory testing equipment is used to make sure Teletype machines will operate in steamy jungles, 20 miles in space, in deep mines, and on warships, as well as in the modern office.

### RELIABILITY THROUGH DEVELOPMENTAL TESTING

The extensive testing in the development of Teletype sets includes a vibration test and a humidity test. An electronic vibrator shakes the machine to simulate conditions on a jet plane or at a command post in combat. Teletype equipment is also placed into a humid, 130-degree tropic test room to check moisture absorption

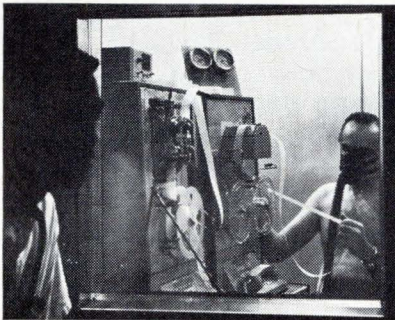

HUMIDITY TEST CHAMBER

rate. This insures that the equipment will operate under the most strenuous physical conditions.

And, still there is more. For instance, the test lab uses a stroboscopic light to "stop" the motion of the paper tape punch mechanism to permit full inspection of the action of rapidly moving parts.

### "THE QUICK BROWN FOX..."

Testing during production is also an important part of the Teletype quality control program. For example, each page printer must produce perfect copy during an exacting typing exercise. If a single mistake occurs, the offending unit is rejected and reprocessed.

Apparatus assembled as sets must undergo a rigid final system test before they are packaged for shipment. Everything possible is done to assure the reliability of every Teletype machine.

### BUT THE BIGGEST TEST IS BY YOU

The reliability of Teletype equipment gets its biggest test in numerous ap-

plications throughout business, government, and industry. Teletype sets are used to keep the ground control center at Cape Kennedy in touch with orbiting space capsules. They transmit weather forecasts and observations. Hotel and airline reservations are made and confirmed by Teletype sets. Railroads use Teletype equipment to maintain optimum freight car inventory; insurance companies for

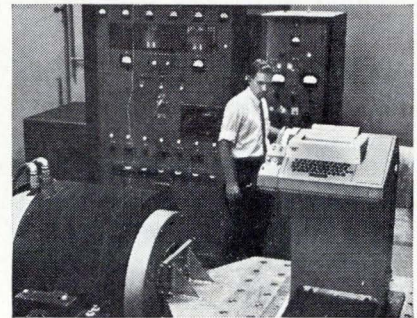

VIBRATION TEST RACK

real-time processing of policy payments and claims; and both large and small companies to speed sales orders to production, shipping, and billing departments.

This kind of reliability is why Teletype equipment is made for the Bell System and others who demand reliable communications at the lowest possible cost. Information on the many applications of Teletype equipment can be obtained by writing: Teletype Corporation, Dept. 71K, 5555 Touhy Avenue, Skokie, Illinois 60078.

## CIRCUIT DESIGN ENGINEERS

for  
Trainers & Simulators

(Southern California)

Important assignments are immediately available for qualified individuals to provide technical direction in the conception and design of trainers and simulators. Must be able to define functional requirements and technical approach, and to guide engineering organizations in the application and advancement of the current state-of-the-art in training devices and simulators. Responsibilities will cover all phases of development from conception to final fabrication and evaluation.

Urgent requirements exist for degree Engineers with a minimum of five years of experience in analog circuitry and display system design or switch and relay logic and digital logic design. Prior experience in the design of training or test equipment is desirable. Should have working familiarity with all applicable government specifications and regulations.

### U.S. CITIZENSHIP IS REQUIRED

For immediate consideration, please airmail confidential resume to:

**MR. B. P. RAMSTACK**

**HUGHES**

HUGHES AIRCRAFT COMPANY

P.O. Box 90515

Los Angeles, California 90009

An equal opportunity employer

## INDUSTRY NEWS

A THREE-COLOR CATHODE-RAY TUBE ALPHANUMERIC DISPLAY for a data processing and control system for the nation's first computer-controlled nuclear reactor will be supplied by a division of International Telephone and Telegraph Corporation. The Industrial Products Division of ITT is producing the high-speed three-color display system for Astrodata, Inc., Anaheim, California, prime contractor to the Atomic Energy Commission for the computer-controlled system. The display equipment includes alphanumeric character generator and a model-KM-906, 19-inch high-speed three-color "Computer-Scope." B. W. Jameson, general manager of the ITT division's instruments department, said that a color tube provides another "dimension" for data presentation and is more useful and versatile than a single-color CRT or conventional lighted display panels.

NCR REPORTS A NEW HIGH IN INCOMING ORDERS FOR ELECTRONIC DATA PROCESSING SYSTEMS DURING THE FIRST HALF OF 1965. Computer orders for the six-month period ending June 30 totaled more than \$50 million in sales value, according to Robert S. Oelman, NCR chairman. This represented an increase of approximately 55% over EDP orders for the corresponding period of last year. The total did not include sales of the company's electronic accounting machines. The impact of NCR's newest modular computer system, the Series 500, was an important factor in the high volume of orders, according to Mr. Oelman.

THE SALE OF A HYBRID COMPUTING SYSTEM TO THE DOW CHEMICAL COMPANY WAS RECENTLY ANNOUNCED BY ELECTRONIC ASSOCIATES. Valued at more than \$500,000, the system is reported to be the largest hybrid computing system ever sold for industrial application. The hybrid computing system will be used for studies ranging from control system design and optimization through industrial dynamics. The major portion of the computer's time, however, will be spent on problems directly related to process engineering and process control, according to the announcement. The computer system is scheduled for completion in late 1965 and will be installed at Dow's Process System Engineering Department in Midland, Michigan.

ITT DATA AND INFORMATION SYSTEMS DIVISION HAS BEEN AWARDED A \$360,000 CONTRACT FOR COMPUTER PROGRAMMING AND SYSTEM TEST SERVICES by the Electronic Systems Division of the Air Force Systems Command. The support services will be performed in connection with the Strategic Air Command's Electronic Data Transmission Communications Centers at SAC Headquarters, Omaha, and major area command centers in Massachusetts, Louisiana, and California. The Strategic Air Command Communication and Control System, originally known as 465L, has been under development since 1958 when the ITT unit, then International Electric Corporation, was assigned over-all management responsibility for the project. A highly automated complex of communications, data processing and display devices, the system is designed to aid SAC in controlling its far-ranging operations.

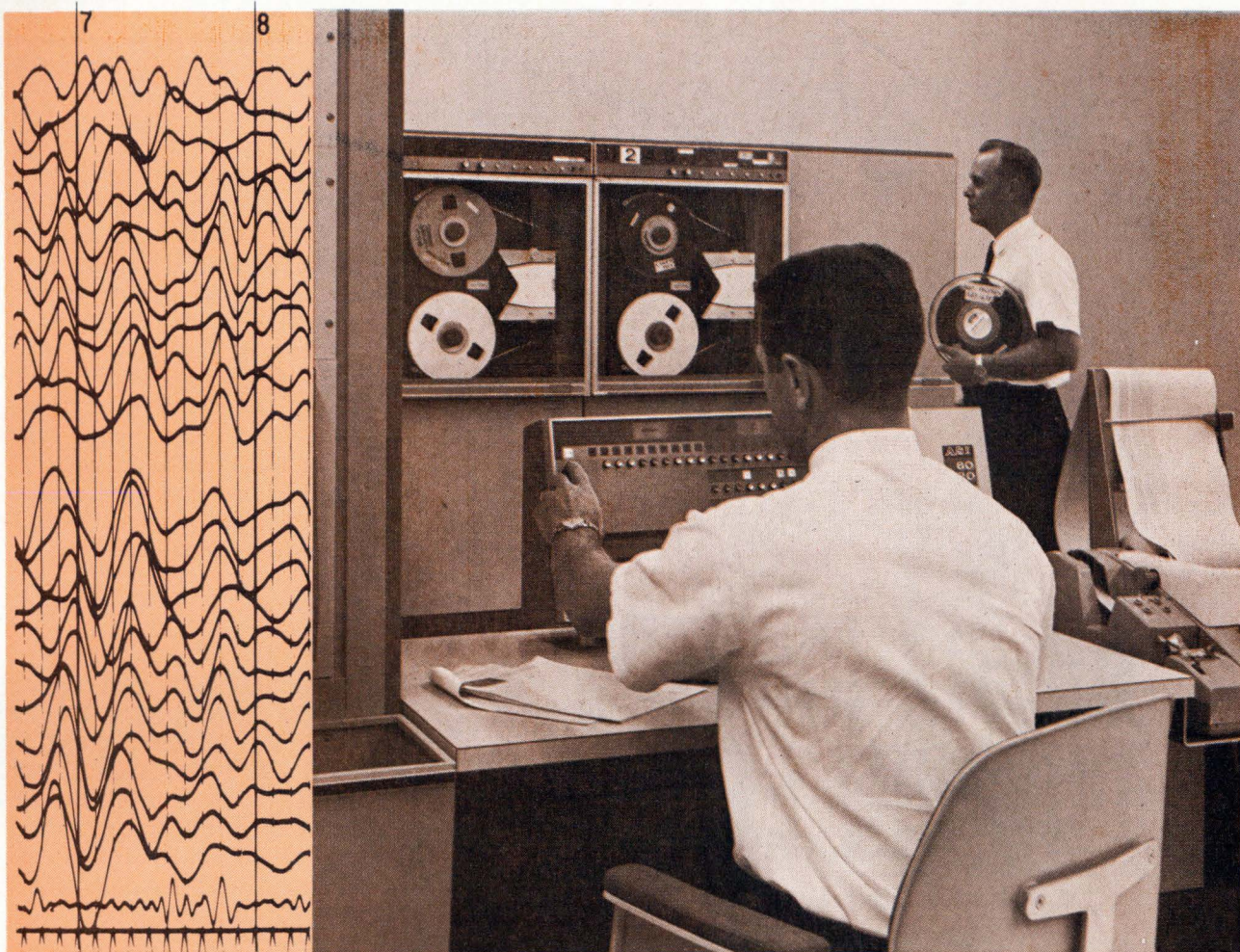

From ASI's continuing program of new product development

## Here is how ASI's systems design solved the seismic data "log jam"

**Problem:** Current geophysical exploration is producing hundreds of thousands of seismic records per month. To make the costly decisions concerning well drilling and placement, the seismic log interpreters require the best input data available. Logs must be corrected and analysis performed, signals must be enhanced and clarified. Earlier methods were both time consuming and inordinately expensive. Intensive competitive pressures and increasing backlogs of data demanded a better solution.

**Answer:** ASI application analysts examined this problem in an intensive study. ASI's answer was a small scale scientific computer combined with special purpose high speed hardware units and utilizing a unique software system.

Since that time, this system has been accepted by a number of major oil companies as being superior to the special purpose digital processors which limit flexibility and as being much more economical than the large scale computers offering similar computa-

tional speeds.

For example, the *ADVANCE* Series Computers can provide corrections to seismic data logs permitting processing of up to 100,000 logs per month at a rental rate as low as \$7,625. The high computation speed and the versatile input/output hardware of the central processor combine with the ASI designed special Seismic Communications Unit and Special Arithmetic Processing Unit to provide the processing power to effect real time throughput of the multi-channel seismic records. Aiding in the real time throughput is a comprehensive, proven set of ASI-written seismic programs.

The solution of this problem did not just happen . . . it was the result of ASI systems-oriented organization. It developed from a thorough understanding of the customers specific requirements. ASI is staffed to solve systems problems other than seismic processing. The ASI brand of imaginative systems design can solve your systems problem.

# ASI

**ADVANCED SCIENTIFIC INSTRUMENTS**

DIVISION OF ELECTRO-MECHANICAL RESEARCH, INC.

8001 Bloomington Freeway, Minneapolis, Minnesota 55420

# 100,000,000 OPERATIONS

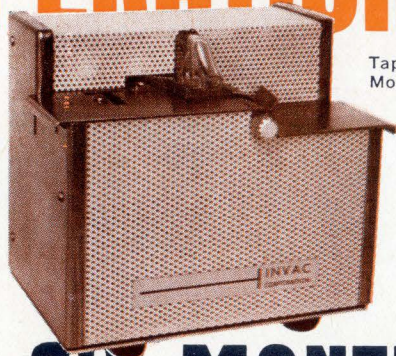

Tape Punch  
Model P-135

## OR SIX MONTHS WITHOUT ERROR

in a Tape Punch backed by an  
Unmatched Guarantee.

Continuous life testing of our Tape Punches reveals that with normal simplified preventive maintenance we can guarantee 100,000,000 operations or six months without error or failure. Invac's Tape Punch, Model P-135, is a rugged solenoid-operated tape perforator only 7 $\frac{3}{4}$ " L x 6 $\frac{1}{4}$ " D x 6 $\frac{3}{4}$ " H and weighs less than 9 $\frac{1}{2}$  pounds. Motors and clutches are eliminated. Operates at 0 to 35 cps with 5 to 8 channels. Punches MYLAR and all other known tape types. Independent of line frequency . . . DC operated. Punch is quiescent during standby. Write for Tape Punch Bulletin.

*Quantity Price: \$391.00    Delivery: 2 weeks*

IT'S INVAC FOR ADVANCED PERIPHERAL EQUIPMENT



CORPORATION

26 Fox Road, Waltham, Mass. 02154 Tel. (617) 899-2380

CIRCLE NO. 12 ON INQUIRY CARD

## INDUSTRY NEWS

ORDERS FROM SIX BRITISH FIRMS FOR ITS SERIES 200 COMPUTER SYSTEMS WERE ANNOUNCED BY HONEYWELL EDP. The total value of the equipment, all of which will be leased, is in excess of two million dollars, according to Robert W. Blucke, director of international operations for Honeywell EDP. The systems will be manufactured at Honeywell's computer production facility in Newhouse, Scotland.

RESEARCHERS AT THE UNIVERSITY OF IOWA ARE DEVELOPING MEANS TO DETECT HEART DEFECTS AUTOMATICALLY WITH THE HELP OF A COMPUTER. When the technique is perfected, it will be possible to examine hundreds of subjects a day so unsuspected heart malfunctions can be found and corrective action started at once. Scientific Data System's 92 computer will be used in the analysis of the sounds from hundreds of hearts and develop a system to distinguish the sounds that may indicate problems. "Our main goal," declared Dr. Donald Epley, head of the University of Iowa electrical engineering department, "is to make heart analysis much more broadly based. We want to be able to record the heartbeats of all the students in a school and then take the tapes to a center where they would be classified automatically." Such analysis would quickly disclose many unsuspected heart problems. These recordings, called phonocardiograms, could be completed in less than a minute. They will seek a recording technique that allows subjects to wear normal clothing.

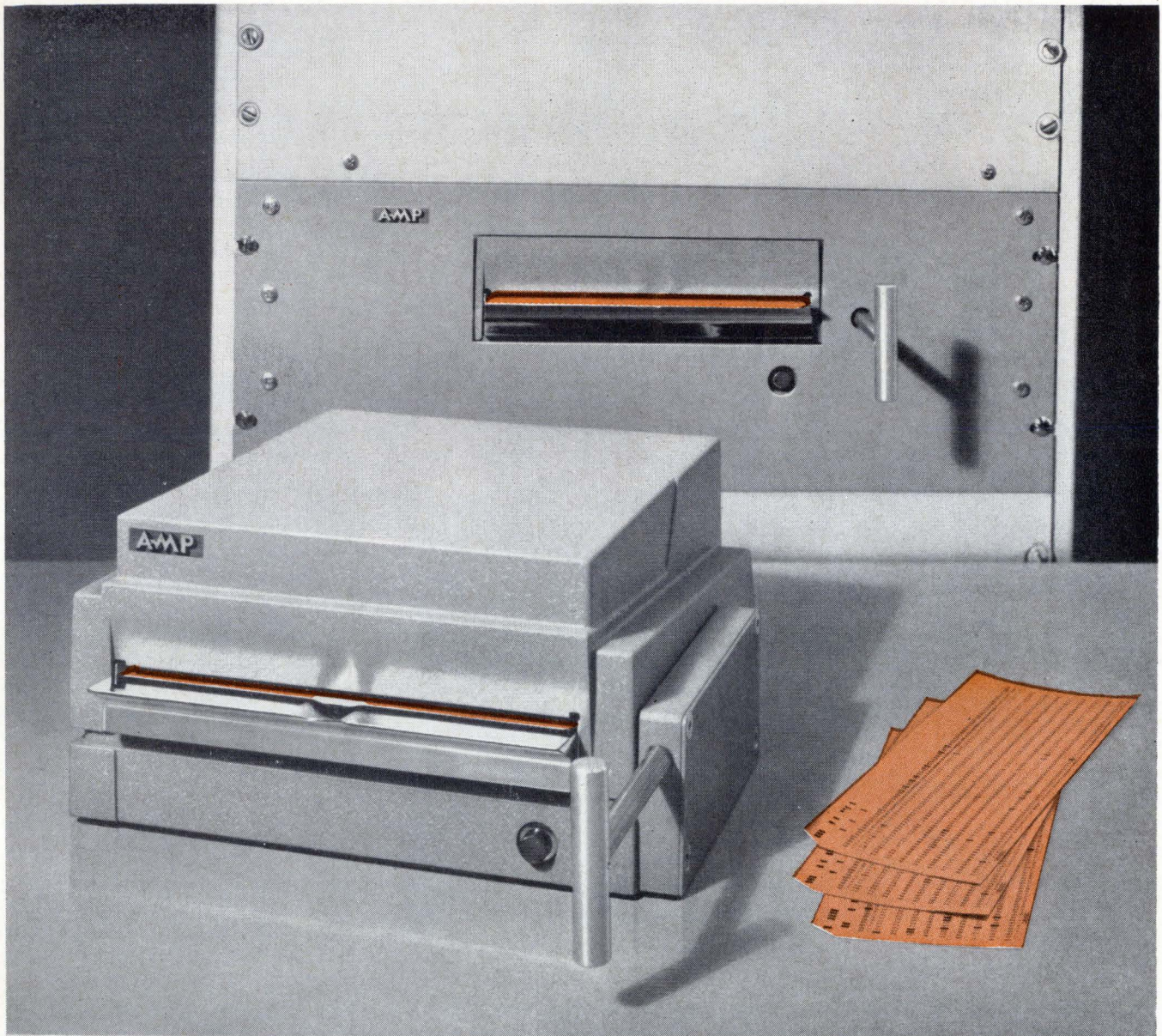

## What's in the cards?

The A-MP★ Card Programming System is designed to find out what's in pre-punched tabulating cards. In fact, this system provides the answers to an unlimited number of applications which require that standard tabulating cards be translated into useful information by electrical impulses. Typical among such uses are—automated process control, test and ground support equipment programming, teaching devices, trainers and simulators, data processing, instrumentation, automated machine control, material handling equipment, and a variety of input-output switching functions.

All programming needs are not the same. That's why we designed the utmost flexibility into our card programming systems. Two versions are available, the desk top style for operation remote from the main body of equipment or the rack mount version which fits a standard 19" relay rack. A selection of pre-wired models including: **12 x 80 matrix; 12 x 80 matrix with diode isolation; 80 inputs, 960 outputs;** or because of their design flexibility, the A-MP Card Programming System can be made in many wiring variations within the basic housing.

Regardless of the wiring configuration you may choose, each system has these engineered features.

- Unique double-wiping action—contacts return from point of maximum travel on printed circuit board to pre-cleaned contact areas to assure reliable sensing
- All contacts are gold-over-nickel plated for long life
- Two-way electrical interlocks prevent false output
- Semi-automatic card ejection
- Rugged, compact construction
- AMPILLUME★ Indicator Light signals that the card is in the "read" position
- Unit can be used for data readout
- Pre-wired to customer specifications

Let us help you select the model best suited for your application. Write today for complete information.

\*Trademark of AMP INCORPORATED



A-MP★ products and engineering assistance are available through subsidiary companies in: Australia · Canada · England · France · Holland · Italy · Japan · Mexico · Spain · West Germany

CIRCLE NO. 13 ON INQUIRY CARD

**HIGH DENSITY  
LOW COST  
INTEGRATED  
CIRCUIT PACKAGING**

**is now called**



**MicroSystem®**

(There are 49 integrated circuits on the card above, interconnected, with room to spare!)

No longer is integrated circuit packaging a high-priced touchy production problem. Now there is MicroSystem®, the new concept in practical, reliable, and low cost I.C. assembly developed by Engineered Electronics Company. Just look at these advantages.

**High Density**—As many as 100 flat packs on a single 4x5 card.

**Dependable**—All welded fabrication, no IC lead bending required.

**Versatile**—Any flat pack desired, accommodates design changes without major cost or delay.

**Fast Delivery**—Only 2 weeks for MicroSystem® prototypes, 4 weeks for production.

**Low Priced**—A fraction of the cost of multilayer boards.

The heart of MicroSystem® is the "stick" element shown here. It is essentially a lamination of flat packs and conductor layers, welded and encapsulated into a finished, plug-in unit. The materials and processes used in assembly permit wide temperature operation. As many as 10 flat packs may be used in a single stick.

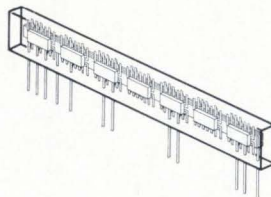

For details on MicroSystem®, complete with circuit layout vellums, write, wire or call...

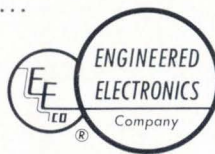

**ENGINEERED ELECTRONICS** Company

1441 East Chestnut Avenue, Santa Ana, California 92702  
(714) 547-5651 • TWX (714) 531-5522 Cable ENGELEX

**INDUSTRY NEWS**

A CONTRACT TOTALING MORE THAN \$500,000 TO SUPPLY DIGITAL CIRCUIT MODULES to Linofilm-Mergenthaler, a division of Eltra Corporation, has been awarded to Wyle Labs of El Segundo, Calif. The circuits will control the automatic operation of the Linofilm "QUICK" phototypesetting system produced by Mergenthaler. The system employs a low-cost, high-speed automated phototypesetting machine. The machine reads a standard six-level justified punched tape which may be prepared on any conventional justifying perforator, and produces type on either photographic film or paper in a variety of type sizes and styles.

THE FOXBORO COMPANY'S DIGITAL SYSTEMS DIVISION OF NATTICK, MASS., HAS PURCHASED SIX CENTRAL PROCESSORS AND PERIPHERAL EQUIPMENT FROM DIGITAL EQUIPMENT CORP., for use in Foxboro's Model 97000 Digital Industrial Process Control Systems. The processors, designed and built by Digital to specifications drawn by Foxboro, are functionally equivalent to Digital's general-purpose PDP computers but with more extensive input/output system built by Foxboro to meet specific needs of real-time industrial process control. They are being used in systems built by Foxboro for the Board of Public Utilities in Kansas City, Kans.; the Central Electric Power Cooperative of Conway, S.C.; Associated Electric Cooperative of Thomas Hill, Mo.; Chase Brass & Copper Company of Montpelier, Ind.; and Allegheny Power System's Fort Martin Station in Fairmont, W.V.

**DESIGN LAYOUT VELLUMS**

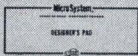

A layout vellum to simplify your MicroSystem® IC designs is yours for the asking. Easy-to-use, it also includes a detailed explanation of MicroSystem® construction.

CIRCLE NO. 14 ON INQUIRY CARD

A \$450,000 CONTRACT TO DEVELOP A SPECIAL MINIATURE INTEGRATED CIRCUIT AIRBORNE COMPUTER FOR A U. S. NAVY PROJECT has been awarded to Control Data Corp., by Sanders Associates, Inc. This airborne computer, including 8,192 words of memory, is only 0.6 of a cubic foot in size, weighs 35 pounds, and has a maximum power consumption of 125 watts. It has a basic memory size of 4,096 24-bit words that is expandable to 32,768 24-bit words. One of its outstanding features is said to be its in-out/output capability, both parallel and serial. The computer can accommodate 12 selectable input devices and five output devices at the same time.



**converting a couple of hundred  
analog inputs  
directly to IBM-format mag tape  
was no sweat**

for the world's worst bridge player.  
How do you figure some guys?

George Stout's the red-hot who designed the EECO 755 Data Recording System. But he'd have trouble making a small slam with 13 spades in his hand.

He's very glib in pointing out the EECO 755 digitizes as many as 200 inputs at sampling rates up to 166 channels a second. With  $\pm 0.05\%$  accuracy. And that it records 500 tape characters per second, and that it handles inputs from  $\pm 50$  mv full scale to  $\pm 5$  volts with 100-megohm impedance. He says it's in the same price range as much slower recording systems.

But try to get an intelligent bid out of him. He doesn't know the Blackwood convention from a hole in the card table.

The system itself looks pretty much standard on the outside ... tape recorder up top, a few dials here, a couple of patch panels there. So we thought you'd rather see a picture of George in action. Of course if you want to get stuffy about it, we do have a data sheet on the EECO 755 we'll part with (reluctantly). It's got specifications and a few block diagrams. George is very proud of it. He thinks he's a writer, too.



**Electronic Engineering Company**  
of California

Box 58, Santa Ana, California 92702 • Phone (714) 547-5501

CIRCLE NO. 15 ON INQUIRY CARD

A LOW-POWER COMPUTER MEMORY FOR AEROSPACE APPLICATIONS IS NOW UNDER DEVELOPMENT AT BUNKER-RAMO CORP'S DEFENSE DIVISION. The work is being performed under a contract with the Systems Engineering Group, Research and Technology Division of the Air Force Systems Command at Wright Patterson AFB. Emphasis is being placed on the use of metal oxide semiconductors (MOS) and batch fabrication techniques that will make the memory economical to produce. A 1000-word, 30-bit, 2-sec MOS memory will be developed and a conceptual 2000-word memory will be designed on paper. Bunker-Ramo has already fabricated a 200-nanosecond monolithic integrated circuit memory as a scratchpad under company sponsored research programs and the low power memory will be an extension of the effort. The Bunker-Ramo memory will be more compatible with integrated circuits and will also be organized to afford a significant reduction in the power requirements of the memory subsystem.

A SUMMARY OF A SPECIFIC TECHNICAL INNOVATION DERIVED FROM THE SPACE PROGRAM. ISSUED BY THE TECHNOLOGY UTILIZATION DIVISION OF NASA.

# LOGIC REDUNDANCY IMPROVES DIGITAL SYSTEM RELIABILITY

## THE PROBLEM

In binary-signal systems, the generation of false ZEROS and false ONES due to noise or faulty equipment are not uncommon. These false signals result in errors in communication or computation and repetition of message is not always feasible.

## THE SOLUTION

A redundant-channel system that automatically corrects any single error in a set of three binary signal channels.

## HOW IT'S DONE

The system is composed of four parts as shown in the illustration:

- (1) Simultaneous binary signal sources **a**, **b**, and **p**;
- (2) Signal channels 1, 2, and 3;
- (3) Temporary storage elements **q**, **r**, **s**, **t**, **u**, and **v**;
- (4) Logic circuits consisting of parity functions and majority functions.

Signal sources **a** and **b** are independent but source **p** produces a signal that is the parity function of **a** and **b**, that is, it is 1 if **a** and **b** are unlike, and 0 if **a** and **b** are like values. In a computer, if **a** and **b** are logical functions of a set of variables, **x**, **p** may be derived directly as a combinational function of **a** and **b**, or indirectly from the same set of variables, **x**. In this system, identical values of **a**, **b**, and **p** are produced twice. The first set of values **a**, **b**, and **p** are transmitted through channels 1, 2, and 3, respectively, and stored in elements **q**, **s**, and **u**, these transmissions being represented by the heavy solid lines in the figure. The second set of values of **a**, **b**, and **p** are transmitted (along the dotted lines) through channels 2, 3, and 1, respectively, that is, transposed with respect to the first transmission, and stored in elements **r**, **t**, and **v**. The signals  $\alpha_c$  and  $b_c$  are generated by the combinational logic elements as the following functions:

$$\alpha_c = \text{majority function } (q, r, [t \oplus u])$$

$$b_c = \text{majority function } (s, t, [q \oplus v])$$

where the majority function of three binary variables is defined as being 1 if, and only if, two or three of the variables are 1, and the symbol  $\oplus$

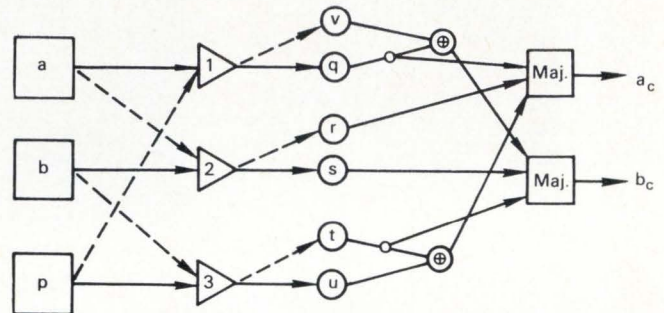

represents the parity function of the associated variables as defined above. The functions  $\alpha_c$  and  $b_c$  are the true values of the independent signals **a** and **b**, respectively, if there is no more than one faulty channel. The explanation of this for  $\alpha_c$  is that: if channels 1, 2, and 3 are perfect then **q**, **r**, and **v** have the value **a** and  $[t \oplus u]$  also has the value **a**, since  $t = b$ ,  $u = p$  [ $\alpha \oplus b$ ], and  $(b \oplus (\alpha \oplus b)) = \alpha$ . Finally, the majority function of  $(\alpha, \alpha, \alpha)$  is **a**. If one of the channels fails, only one of the values **q**, **r**, or  $[t \oplus u]$  may differ from the others, so that the majority function of the three still has the value **a**. The explanation for  $b_c$  follows a similar argument.

## NOTES

1. This system could be used to correct signal channel errors in applications where data is transmitted naturally in parallel channels, such as within a digital computer, and where the channel is substantially less reliable than the associated correction equipment.
2. Inquiries concerning this invention may be directed to: Technology Utilization Officer, Jet Propulsion Laboratory, 4800 Oak Grove Drive, Pasadena, Cal. 91103. Reference: B65-10025.

## PATENT STATUS

NASA encourages the immediate commercial use of this invention. Inquiries about obtaining rights for its commercial use may be made to NASA, Code AGP, Washington, D.C. 20546. **END**



Winchester Electronics announces  
a revolutionary New Series of

# SUBMINIATURE REMOVABLE CRIMP CONTACT CONNECTORS!

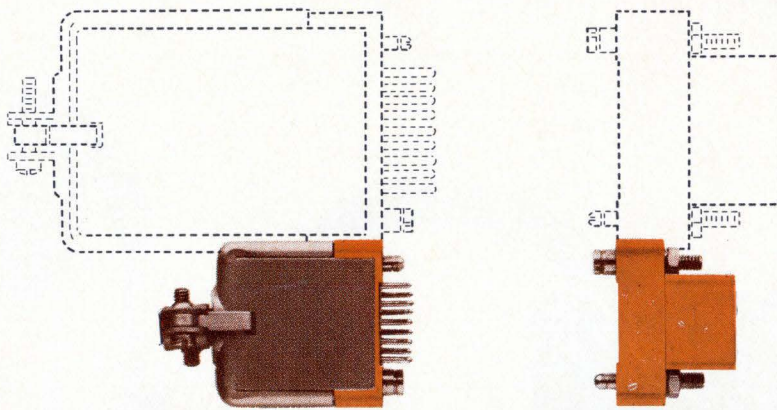

- **50% Size Reduction** • **Crimp Reliability** • **High Contact Density**

(As Compared To MIL-C-22857  
Connectors Outlined Above)

Meet the new Orange Ball family of subminiature connectors from Winchester Electronics. They're small, light weight and feature both crimp reliability and high contact density. Contacts are 0.030 inch in diameter and are spaced 0.094 inch center to center.

These tiny connectors are offered in 7, 14, 20, 26, 34 and 50-contact sizes. Contacts are rated at 5 amps and crimp to No. 24, 26 or 28 stranded wire with four 90-degree indentations for positive retention. Pins and sockets are of solid, machined construction for highest reliability. Moldings are glass-filled, diallyl phthalate per MIL-M-14, Type SDG-F. Of course, there's a wide selection of accessories for these light, compact, self-aligning rack and panel connectors, including several types of jack screws and guides.

The Orange Ball series is ideal for applications requiring high reliability and compactness plus the convenience and economy of removable crimp contacts. Avionics, instrumentation, computers and portable equipment are examples. They're also interchangeable with the popular Winchester Electronics SRE series. For details, contact your local regional office or write: Main Street and Hillside Avenue, Oakville, Connecticut.

*New 1965 Handbook of Standard Connectors  
now available. Write, wire or call for your copy.*

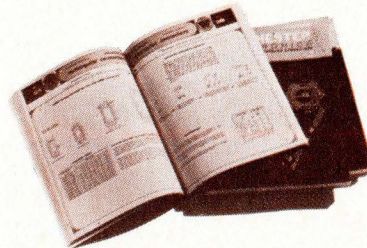

 **WINCHESTER ELECTRONICS**  
DIVISION OF LITTON INDUSTRIES

CIRCLE NO. 16 ON INQUIRY CARD

**PRODUCT REFERENCE FILE**

Background concepts, selection criteria, and application information on a class of products used by digital design engineers.



**RICHARD PETTERSEN,**  
Contributing Editor

Most data processing installations eventually use both punch cards and paper or magnetic tape, and hence the necessity of regularly converting data from one form to the other. For the user with a large-scale computer system this presents no problem — the system normally includes several alternate methods of performing the conversions.

Most users do not start off with million-dollar-plus systems, however. Typically, a company with accounting, statistical, or other data handling problems will have picked up some tab card equipment somewhere along the line; partly because such equipment is well-known, simple to use, and relatively economical; partly because it works with physically discrete blocks of data which are well suited to manual sorting, filing, mailing, and visual inspection. When the data handling installation expands to the point of including an electronic data processor of some sort, punch cards are found to be uneconomically slow for direct input/output (and speed is, after all, the only real advantage of EDP). The user must find some means of translating punch card data to paper or magnetic tape for input, and sometimes

translating output tapes back onto punch cards.

The result is a small but steady market for card-to-tape and tape-to-card converters, and the potential user has some variety to choose from.

Computer manufacturers generally prefer to concentrate on larger systems and do not offer card/tape converters as separate items (a notable exception is IBM). RCA has withdrawn its off-line 527 Card Transcriber and 537 Transcribing Card Punch from the market, and now offers only on-line conversion through its 301, 3301, and Spectra 70 systems. Similarly, Philco prefers to use its Model 1000 computer for such conversions — but the 1000 is available only as a satellite to the large-scale 2000 systems.

The off-line conversion units which are available differ considerably in capability and price. A typical card-to-tape converter consists of a card reader, a decoding/encoding matrix, control logic, a buffer if card and tape rates are very different, and a tape unit. In evaluating systems, the user must determine how many of these black boxes are included as part of the converter and how many he must himself fur-

nish, what the maximum conversion rate is (limited sometimes by the card reader, sometimes by the tape unit), what codes can be read and written, physical and operational characteristics, and, of course, price. Tape-to-card converters, somewhat less in demand, must be evaluated on essentially the same criteria.



Ampex Corp.'s Model CTS-200 card-to-magnetic tape converter.

## MANUFACTURERS' UNITS

Accompanying this survey article is a chart entitled "Characteristics of Card/Tape Converters" which summarizes the major characteristics of commercially-available conversion systems. To supplement this chart, brief descriptions of each manufacturer's system are given below.

### Card/Magnetic Tape Systems

**Ampex Corp.**, Redwood City, Cal. — Model CTS-2000 Card-Tape Conversion System is the first of Ampex's new series of off-line media conversion systems. The CTS-2000 reads 51-column or 80-column cards and records the data on magnetic tape in IBM format at 200, 556, or 800 bpi density. "Extensive computer-like editing, formatting, and automatic error-checking features" are incorporated. Four versions, ranging in speed from 400 to 2000 cards per minute and in price from \$24,000 to \$38,000 are available for varying requirements. Lease or purchase of the system includes full maintenance contract services.

**Data Systems Inc.**, Detroit, Mich. — DSI-1000 Conversion System operates under manual or computer control to convert punch card or

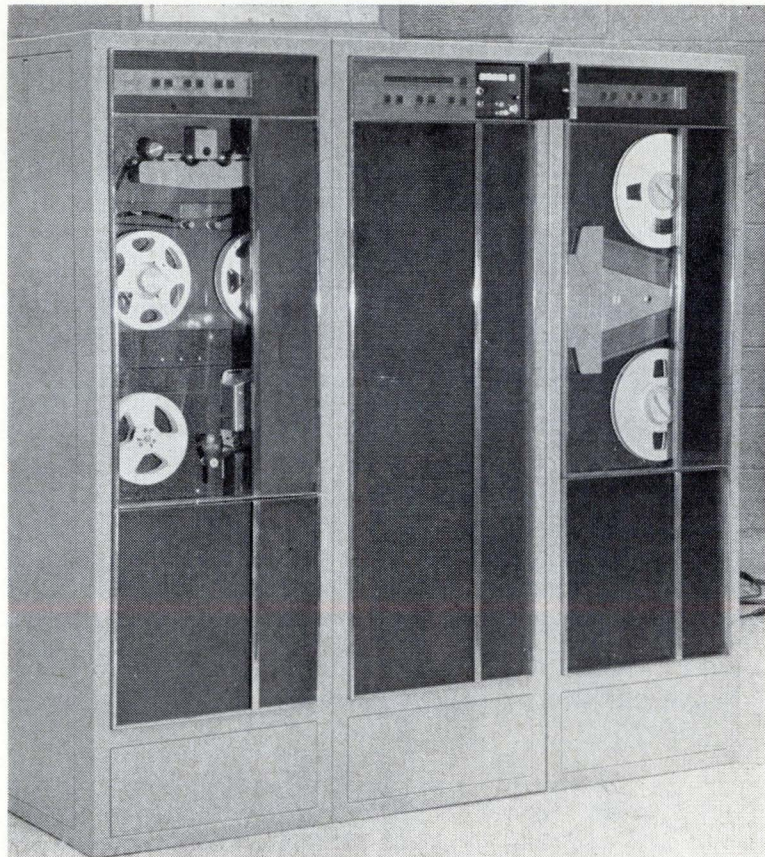

Data Systems' Model DSI-1000 card-to-magnetic tape converter.

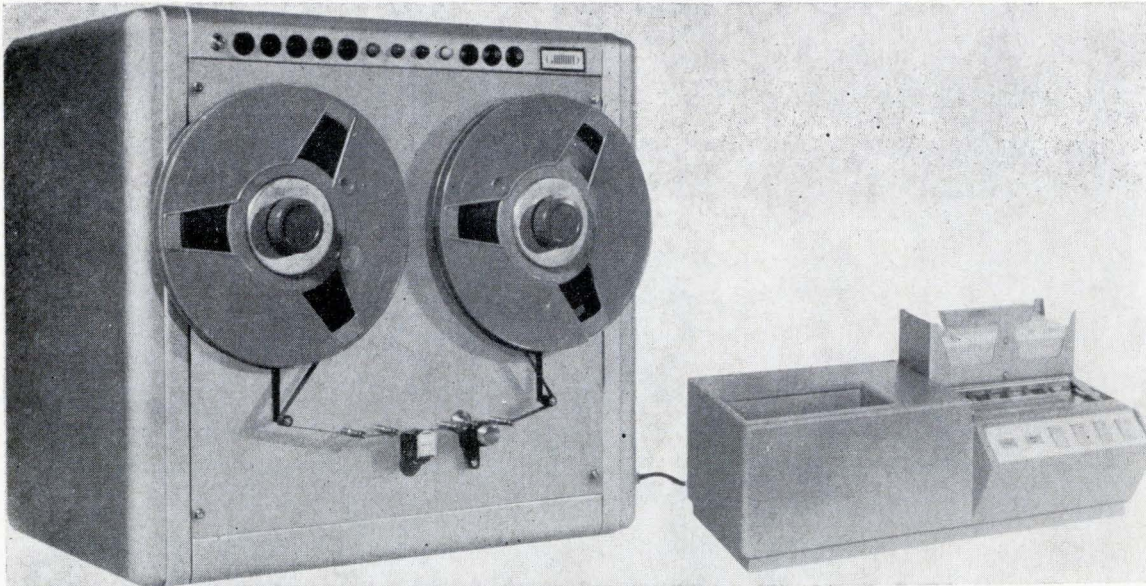

General Dynamics' Model SC-332D card-to-magnetic tape converter.

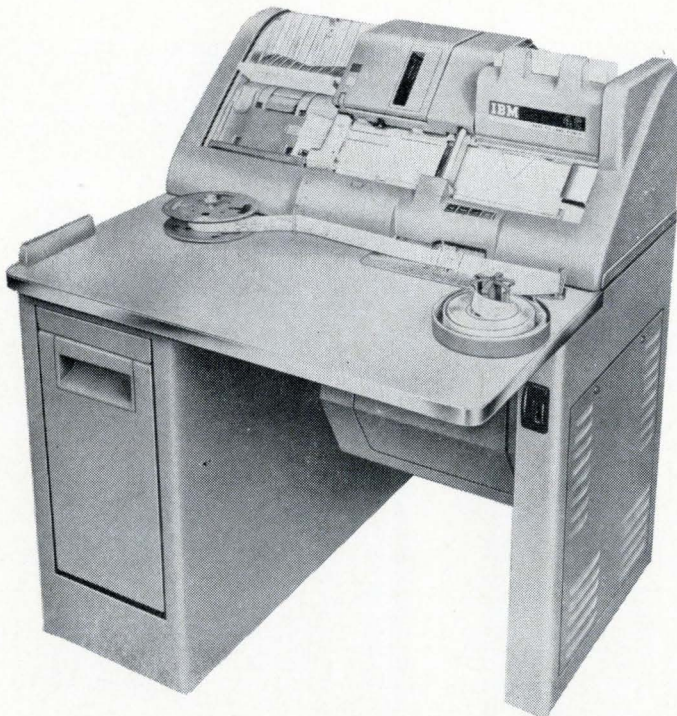

IBM Corp.'s Model 046 paper tape-to-card converter.

paper tape data to IBM-compatible magnetic tape at 200 or 556 bpi. Operating under stored programs available from the manufacturer, the system is also capable of conversions between several other media (computer-to-incremental plotter, tape-to-computer, Dataphone terminal) and from one code to another. For card-to-tape use, systems are offered at 100, 200, or 800 card-per minute rates, at prices from \$20,000 to \$100,000. The programmable conversion unit includes random-access storage for 1024, 12-bit words or 2048, 6-bit words.

**General Dynamics Electronics**, Rochester, N.Y. — Offers a desk-top card-to-magnetic tape converter as an adjunct to its SC-332 line of tape-tape converters. The Model SC-332D includes a reader capable of handling 100, 80-column cards per minute and an incremental tape unit which records at either 200 or 556 bpi density. Conversion is performed by a diode matrix under plugboard control, with provision for combining or deleting characters. Parity checking is included. Price, including card reader and tape unit, is under \$14,000.

#### **Card/Paper Tape Systems**

**Digital Electronic Machines, Inc.**, Kansas City, Mo. — Desk-top unit

49,152 BITS

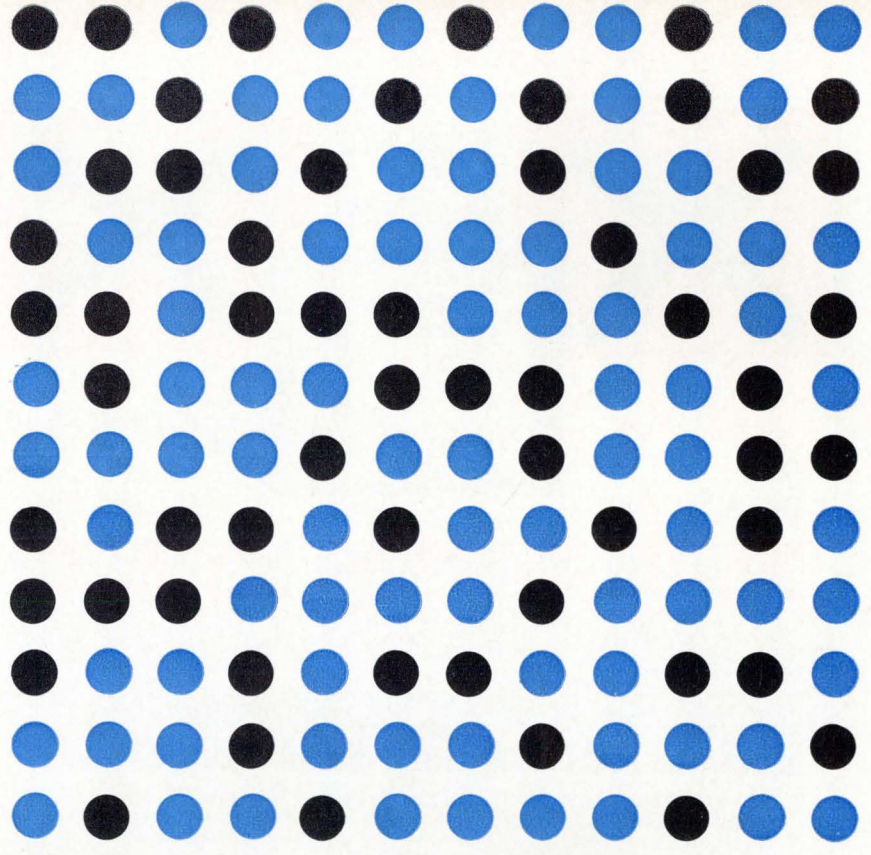

**49,152 BITS**  
**OF CONSTANT-STORAGE MEMORY**

**OR 4,096** <sup>12-BIT</sup> **WORDS**  
**OF READ-ONLY MEMORY**

# MODEL 4700

## MAGNETIC CODE CONVERTER

FOR COMPUTER PROGRAMMING; SHAFT-ANGLE TO TANGENT CONVERTERS; CHARACTER GENERATION; EMPIRICAL DATA STORAGE

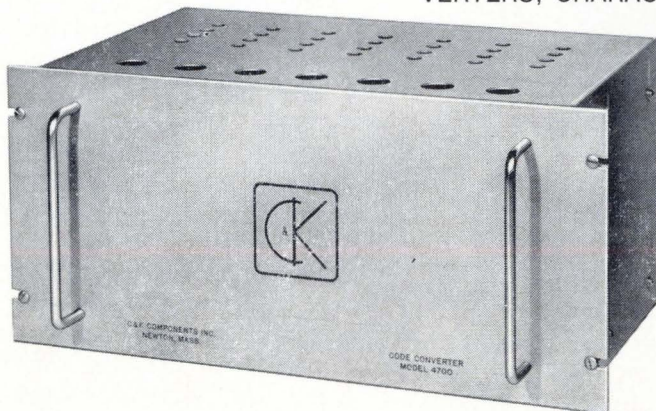

Model 4700 Magnetic Code Converter utilizes magnetic cores and micrologic circuitry to provide readouts of arbitrary binary functions. The unit accepts a 12-bit "argument" as an *input* and produces a parallel 12-bit "function" as an *output*. A single *read* command is required to initiate the entire code conversion operation. *Read* commands may occur as often as once every three microseconds! Outputs appear less than 0.8 microseconds after the start of the *read* command.



low power digital/magnetic timing and control devices

103 Morse Street, Newton, Massachusetts 02158  
Telephone: 617 926-0800



**ELIMINATES  
THE  
MIDDLEMAN!**





AN INCREMENTAL RECORDER  
FOR ONLY  
**\$3750.<sup>00</sup>**

COMPLETE, READY TO OPERATE  
Build it in (Rack Mount)  
or carry it (Portable)

**DIGI-DATA'S**

**DIGITAL STEPPING RECORDER**

**STORE DATA AT ANY RATE — 0 TO 400 CHARACTERS PER SECOND**

**READ ON ANY IBM COMPATIBLE TRANSPORT**

**GENERATES FULLY COMPATIBLE IBM TAPE AUTOMATICALLY!**

- Choice of 200 or optional 556 bits per inch
- Standard IBM type 10½" reels, ½" tape
- 7 track standard spacing
- ¾" inter record gap with longitudinal check character
- Lateral parity selectable — odd or even
- For additional information, phone or write

**DDC** DIGITAL STEPPING RECORDERS  
DIGITAL DATA HANDLING EQUIPMENT  
DIGI-DATA CORPORATION

Main Office: 4315 Baltimore Ave. • Bladensburg, Md. 20710 • (301) 277-9378  
Western Regional Office: 4341 W. Commonwealth Ave. • Fullerton, Cal. 92633 • (213) 941-3182

CIRCLE NO. 18 ON INQUIRY CARD

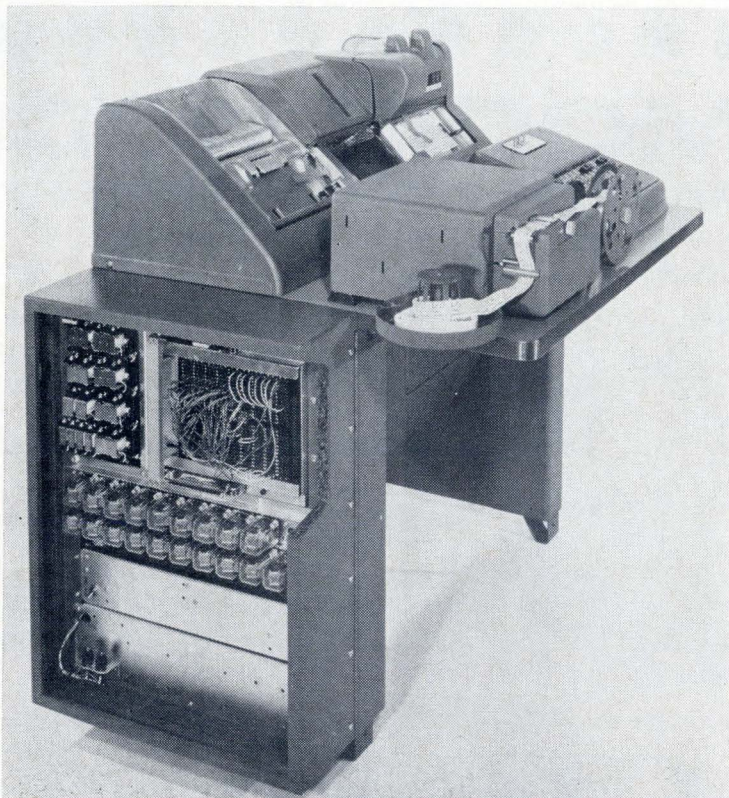

Systematics' Model C750 paper tape-to-card converter.

converts edge-punched or hand-punched cards (including mixed decks) to 8-level paper tape at a rate of 800 characters per minute. The Model TPU-64, priced at about \$2400, includes the manufacturer's card reader, a Friden tape punch, and a diode matrix/pc board converter. Optional features include other tape codes, and operation into other devices such as keyboard, printer, or teletypewriter equipment. IBM Corp., White Plains, N.Y. — Offers both card-to-paper tape and paper tape-to-card converters. The Model 063, renting at \$75.00 per month, reads 80-column punch cards at a rate of 10 columns per second and translates the data to 5-channel telegraphic paper tape. Operation is controlled by an adjustable skip bar and control panel wiring.

The IBM Models 046 and 047 tape-to-card punches are essentially Model 024 and 026 keypunch units, respectively, with a tape reader permanently attached to the desk top. (The 026 prints on the card; the 024 does not.) Two sub-models are offered for each type. The Model 1 reads either 5 or 8 channel tape; the Model 2 reads only 8 channel tape. Both punch 80-column cards. The conversion rate is 20 columns per second for the 046 and 18 columns per second for the 047. Rental is \$135 to \$140 per month.

Systematics, Div. of General Instrument Corp., Hawthorne, Cal. — K-177 card-to-paper tape system, called the Universal Code Converter, is capable of reading 51, 66, or 80-column cards with Hollerith, column-binary, or EBCDIC codes. It produces 5, 6, 7, or 8-channel paper tape in IDP, EDP, or FieldData codes. The converter also features flexible programming via quick-change plugboards as well as by control cards on the card reader. Physically, the conversion unit attaches to one pedestal of an IBM 024 or 026 keypunch, which can be used normally when the converter is turned off. Speed is limited by the keypunch to 20 characters per second. Price, including the punch but excluding the IBM unit, is approximately \$4,000.

The same manufacturer offers a paper tape-to-card converter in its Model C750 which reads the same

# < 3 microseconds write to read recovery time -

Where else can you find this remarkably low recovery time, less than 1 bit in  $10^{12}$  bits transient error rate and single bit alteration phase modulation recording — all at one megacycle data rate? At Magne-Head, these are standard

features — not extra-cost “options.”

Comparison is the key to your best buy. For Magnetic Drum Memory Systems — designed... engineered... and manufactured to your exact requirements, contact Magne-Head today.



**MAGNE-HEAD** *a division of General Instrument Corp.*

13040 South Cerise Avenue • Hawthorne, California 90250 \* 213 679-3377/772-2351 • TWX 910-325-6203

CIRCLE NO. 19 ON INQUIRY CARD

# MELPAR GROWTH CREATES IMMEDIATE OPENINGS IN OUR ADVANCED COMPUTER LABORATORY

## SYSTEMS DESIGN

Development and analysis of complete digital computer system requirements for command and control applications. Requirements include experience in the analysis of real-time, man-machine systems.

## PROGRAMMING

Symbolic and machine language programming of real-time computer - controlled man - machine systems. Requirements include experience on CDC 160, CDC 160A, DDP 24, PB 250, PB 440, SDS 910, or SDS 920 series equipments.

## LOGIC DESIGN

Design, development, and system integration of interface and special-purpose computer equipments. Requirements include experience with solid-state digital logic circuits and computer interface equipments.

Write to Clarence Endsley  
Professional Placement



## MELPAR INC.

A SUBSIDIARY OF WABCO

7708 ARLINGTON BLVD.  
FALLS CHURCH, VA.

(10 miles S.W. of Washington, D. C.)

*An equal opportunity employer*

CELEBRATING OUR  
20TH YEAR IN  
SPACE AND DEFENSE

CIRCLE NO. 901 ON INQUIRY CARD

## CHARACTERISTICS OF CARD/TAPE CONVERTERS

Manufacturer	Model	Type	Limiting Rate	Card Columns	Tape Channels	Accessories	Price
Ampex Corp.	CTS-2000	Card-Mag.	400-2000 cards/min	51, 80	9	Reader, Tape Unit	24K to 38K
Data Systems, Inc.	DSI-1000	Card-Paper	500 cps	80	5, 6, 7, 8	Reader, Punch	20K to 100K
	DSI-1000	Card-Mag.	100, 200, or 800 cards/min	80	9	Reader, Tape Unit	20K to 100K
Digital Electronic Machines, Inc.	TPU-64	Card-Paper	14 cps	80, Edge	8	Reader, Punch	2395
General Dynamics	SC-332D	Card-Mag.	100 cards/min	80	9	Reader, Tape Unit	13,620
IBM Corp.	065	Card-Paper	10 cps	80	5	Reader, Punch	75/mo.
	046, 047	Paper-Card	20 cps	80	5, 8	Reader, Punch	135-140/mo.
Systematics (Div. of General Instrument Corp.)	K-77	Card-Paper	20 cards/min	80, 66, 51	5, 6, 7, 8	Punch	4150
	C750	Paper-Card	20 cards/min	80, 66, 51	5, 6, 7, 8	Reader	3750

TABLE 1 • MANUFACTURERS' LITERATURE

For your product reference file, a complete set of manufacturer's literature can be obtained by circling the reader inquiry numbers listed below.

COMPANY	INQUIRY CARD NO.
AMPEX CORP., Redwood City, Cal. . . . .	71
DATA SYSTEMS, INC., Detroit, Mich. . . . .	72
DIGITAL ELECTRONIC MACHINES, INC., Kansas City, Mo. . .	73
GENERAL DYNAMICS/ELECTRONICS, Rochester, N.Y. . . . .	74
IBM CORP., White Plains, N.Y. . . . .	75
SYSTEMATICS, Div. of General Instr. Corp., Hawthorne, Cal.	76

variety of paper tape codes noted above and causes the keypunch to punch out the selected card code on the selected card type. Programming is again by plugboard and program card, and the physical configuration is similar. The tape reader can be placed on the desk of the keypunch. Price, excluding the keypunch, is under \$4,000.

## SUMMARY

For a complete reference file on this subject, we recommend that the reader supplement this survey article with a set of company brochures and technical data sheets. The list of manufacturers in Table 1 is keyed with reader inquiry numbers for your convenience in requesting this material.



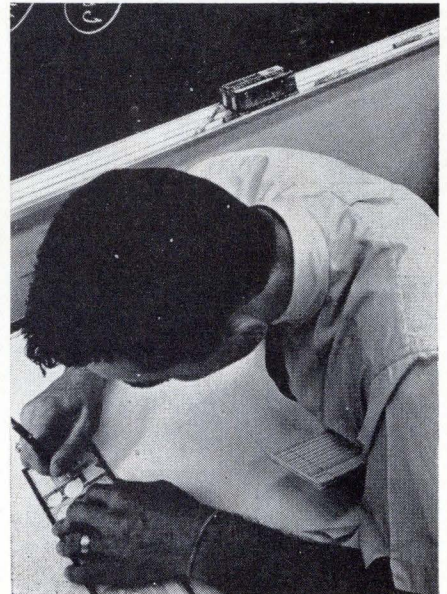
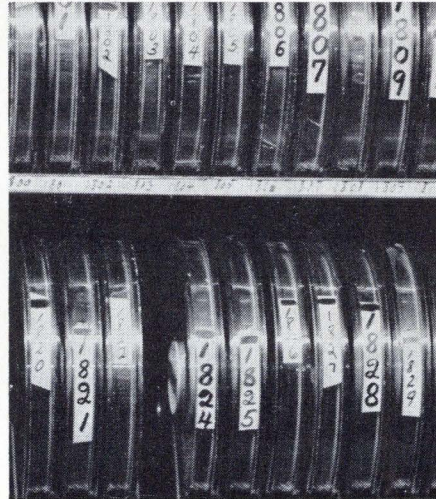
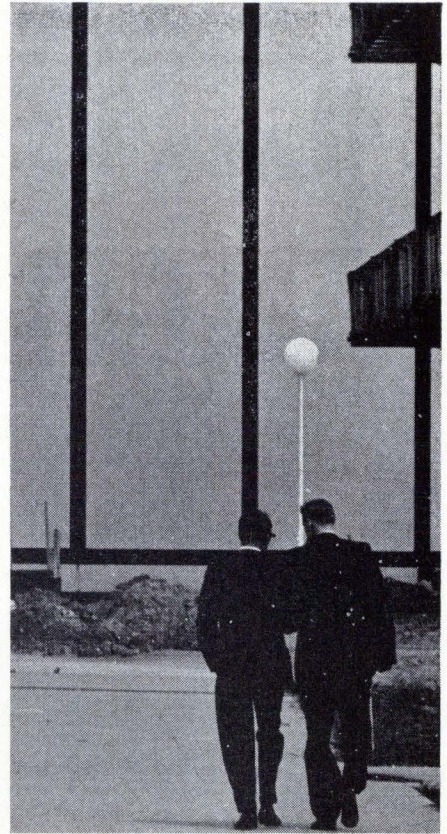
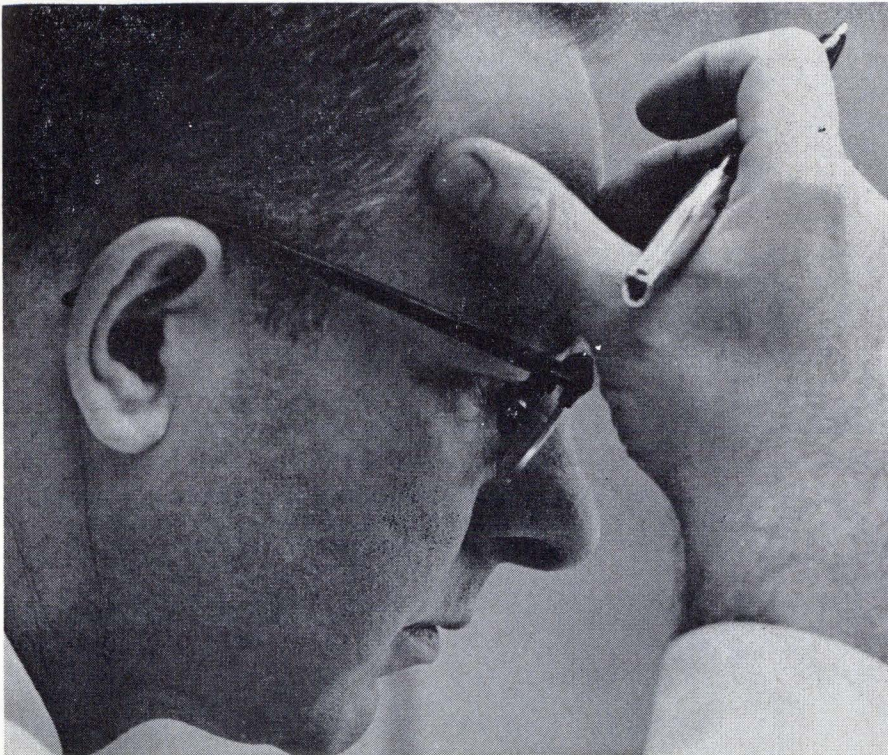

# GROW WITH WOLF

Wolf Research and Development Corporation has continuously expanded and diversified to meet the growing challenges of our nation's aerospace program. At NASA's Manned Spacecraft Center in Houston, Texas, Wolf personnel are playing a key role in the success of the Apollo project. Its Washington, D. C., office is engaged in space science studies and programming services for NASA's Goddard Space Flight Center and NASA Headquarters. In the Boston area, WRDC is now providing analysis and programming services for NASA's Electronic Research Center in Cambridge, in addition to our service to Project Space Track, AFCRL, and numerous industrial clients. WRDC's latest growth move has been the opening of a Los Angeles office to provide increased commercially-oriented computer services. For over 11 years, WRDC has been solving advanced analytical problems as one of the nation's leading independent scientific consultants. Our reputation has been built on our technical competence.

**SPACE SCIENTISTS** — Mathematicians, Physicists, Geodesists, and Statisticians for advanced analytical studies (advanced degree desirable) at our Washington, D. C., and Concord, Mass., facilities. **SCIENTIFIC PROGRAMMERS/ANALYSTS** — Positions in our Houston, Washington, and Concord offices for Programmers and Analysts with a BS degree in Math, Physics, or Engineering, and programming experience on large-scale computers. Applications in a variety of aerospace problems. **COMMERCIAL PROGRAMMERS** — Personnel with a bachelor's degree and 1410 experience are also needed for our Houston and Washington operations.

For further information, write or phone (617) 646-8192.



**RESEARCH AND DEVELOPMENT CORPORATION**

*an equal-opportunity employer*

CIRCLE NO. 900 ON INQUIRY CARD

P. O. Box 2236, Baker Avenue, West Concord, Mass. 01781

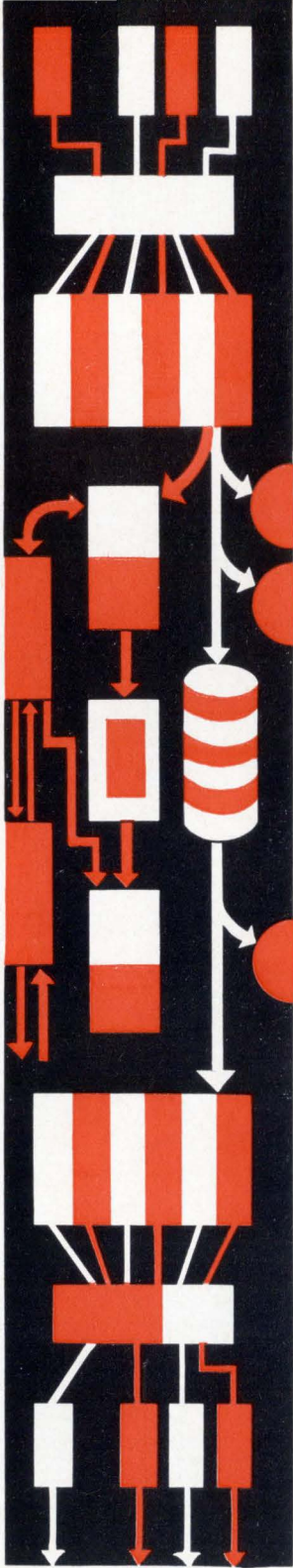

**WALTER A. LEVY**, Contributing Editor  
**EDWARD W. VEITCH**,  
 Pennsylvania Research Associates

**Editor's Note:** Part 1 of this series, in the March 1965 issue introduced the basic system concepts of computer-communications systems; Part 2 in the May 1965 issue evaluated the available techniques for implementing the functions of the Communications Interface Sub-System; and in the August 1965 issue Part 3 described some operational Communications Interfaces. Here in Part 4 the functional aspects of program design are discussed.

## Part 4

### DESIGN GUIDE FOR COMPUTER- COMMUNICATIONS SYSTEMS

# PROGRAM DESIGN-FUNCTIONAL CONSIDERATIONS

Design of real-time systems involves an interplay between equipment and programming considerations. The design of a real-time program requires consideration of two major aspects of the problem.

**Functional aspects** — *what does the program have to do and how must its parts relate with each other and with the equipment?*

**Traffic aspects** — *how fast does the program have to execute its functions and what storage capacity must the system maintain?*

In this part, the functional aspects of program design will be discussed. Traffic aspects will be covered in Part 5, although it will be seen here that functional design depends heavily on the traffic characteristics of the system.

A program generally consists of two parts.

1. The operational program or programs which would be recognized by the external users of the system as doing the specific tasks of the problem; for example, changing an inventory record, calculating an aircraft flight path, etc.
2. The structural programs which serve as the controlling interface between the various hardware elements and between the various operational programs; scheduling and calling in the appropriate routines and scheduling and timing the various peripheral equipments. The former set of programs varies widely depending upon the particular operational function of the system, and generally will not be discussed in detail in this series. However, the structural programs, the problems and methods of real-time control and of scheduling the work, apply to all real-time systems and will be considered here in more detail.

### OVERALL CONSIDERATIONS

The program design cannot be considered independent of the hardware design or hardware selection. The

overall choice of system will normally involve several iterations in which different configurations of hardware will be evaluated; each configuration having different implications upon the program organization. It is of extreme importance during basic planning that the problem to be solved by the system be as completely understood as is reasonably possible, particularly those portions of the problem which require high frequency or rapid actions by the system. This point cannot be overemphasized. There are many examples of good efficient system designs which missed out because they solved the wrong problem or neglected some significant feature.

Before considering the program further, let us review some of the equipment options which are available to the systems designer. First option is the choice of communication interface discussed in some detail in the two preceding parts of this series. Note that this choice is often the most important one in determining the size and speed of processor. The communications flow rate is often such that the choice of one of the more elementary communications interface equipments will mean that the processor must spend up to 90% of its time on the input-output buffering problem.

Second consideration is storage media. The basic processor will, of course, include some comparatively fast access storage, normally, magnetic cores. However, a large volume of storage space may be necessary and it may be desirable to make the system more economical by using a slower speed storage medium in addition to some basic high-speed memory. Possible alternatives are drums, discs, tapes, each with their own advantages and disadvantages. The use of any of these, however, creates a significant buffering and scheduling problem for the programmer.

Third option is the type of processor, and as an added complexity, the possibility of using multiple processors. This latter alternative is being used more and more frequently, although usually because a back-up capability is needed in case of component failure. In either case, however, it introduces additional programming complications.

## STRUCTURAL PROGRAM FUNCTIONS

Table 1 lists the major functions of the structural program. The *Executive* function is concerned with the interface among the operational programs. It calls these in for operation in an appropriate sequence, possibly taking into account the relative priorities of the different functions to be carried out. The program may also make memory assignments. The *Input-Output Monitor* is associated with the direct control of the input-output functions. It will check signals received from peripheral equipment for consistency and in some applications perform a preliminary interpretation of the signals to determine what functions need to be carried out. The *Protective* routines are associated with detection of a failure and implementing a rapid recovery.

### Executive Control and Scheduling

The Executive Control and Scheduling Routines form the heart of the programming system. Fig. 1 shows a

TABLE 1

### STRUCTURAL PROGRAM FUNCTIONS

1. **Executive**
  - Sequence Control
  - Priority Control
  - Memory Allocation and Management
  - Program Interfacing
2. **Input-Output Monitoring**
  - Input-Output Buffering
  - Input-Output Device Interfacing
  - Signal Interpretation
3. **Protective**
  - Record Keeping
  - Self-Test
  - Data Protection
  - Duplexing
  - Recovery after Failure

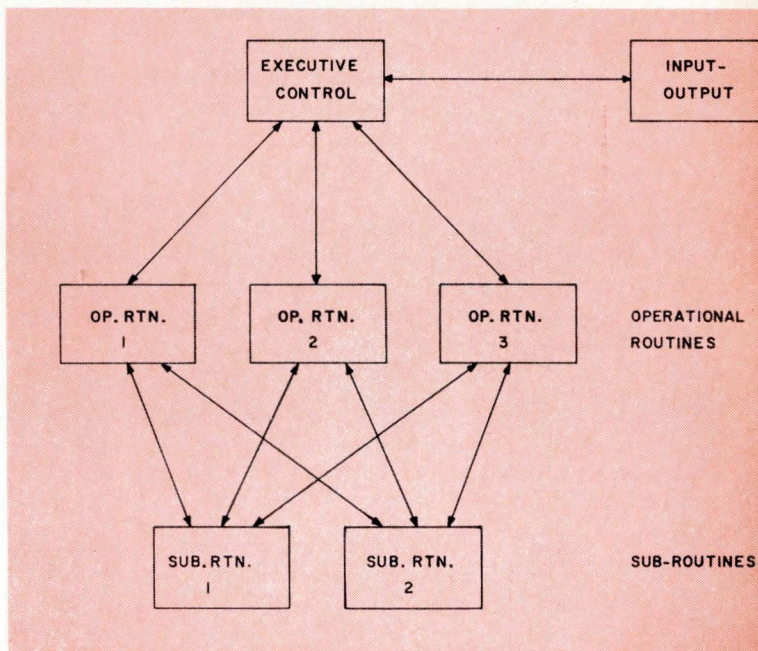

Fig. 1 Overall structure of the program.

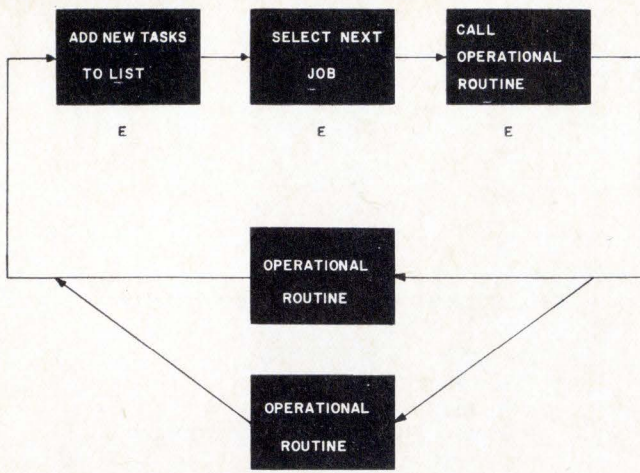

Fig. 2 A Fixed-Cyclic Executive Control (the boxes marked "E" are included in the Executive Routine)

simplified overall structure of the system. The various operational routines do not talk directly to each other. Data and control exchanges between programs are achieved via the Executive program or by the use of common tables accessible by both programs. This constraint is an important one in design. Without it, the individual routines may become so inter-twined that debugging is almost impossible and modifications are very expensive.

There are several different techniques which may be designed into the Executive Routine for scheduling and calling in the various operational routines. These can be lumped into two major categories: cyclic and asynchronous. Generally, the cyclic system is one in which a predetermined sequence is set up for carrying out the various operational programs; the asynchronous system is one in which the sequence is continually changing in accordance with the changing input-output flow of data and operational load.

Sometimes a mixed system is used: for example, the input-output may be treated asynchronously and the internal operations cyclically. Three examples of various systems will be given below to show the variety possible.

1. **Fixed-Cyclic** — an approach often used in a real-time control system where there is a close dependence between input and output and where the computer operates closely with auxiliary analog equipment. For example, suppose that the computer is to supply a signal (e.g., an analog amplitude via a digital-to-analog converter) to a particular output and that this output is to be supplied ten times a second; suppose that there are five such outputs. One approach would be to use a clock signal to mark every 100 milliseconds, ideally through a program interrupt. Following the interrupt, the Executive Routine will call in the five output signal routines; then, if time remains, a computer test routine might be run until the next interrupt. If some inputs or outputs require processing at a different frequency, say five times a second, this might be processed on alternate interrupt cycles. Fig. 2 shows an Executive Routine for scheduling a typical fixed-cyclic system.

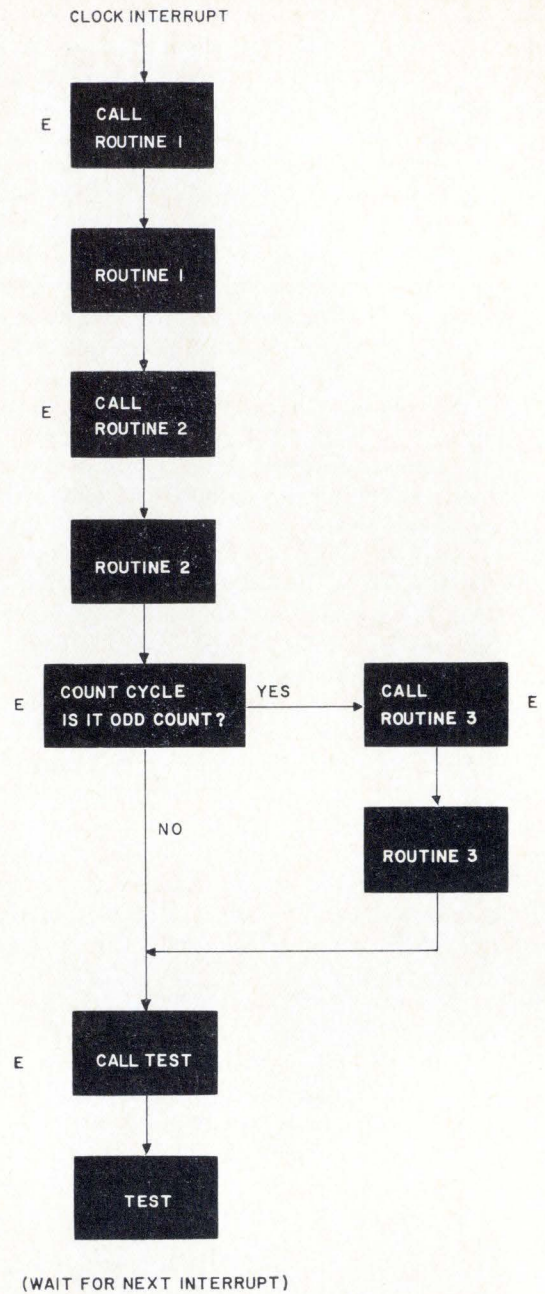
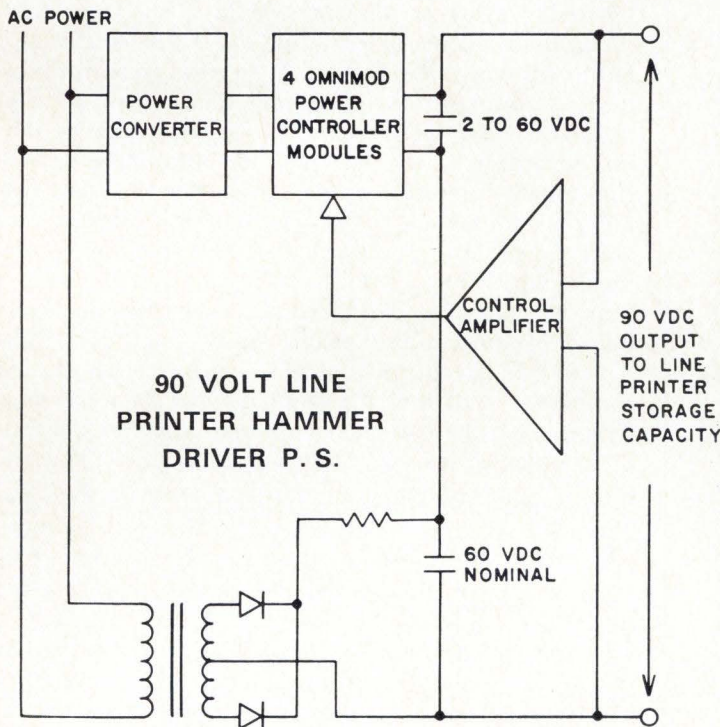

Fig. 3 An Asynchronous Executive (the boxes marked "E" belong to the Executive Routine)

2. **Variable-Cyclic** — sometimes the fixed-cycle constraints are unimportant, or even undesirable. Under these circumstances, a new cycle can be started immediately following the completion of an old cycle. In such a case, the Executive Routine is similar to that of the Fixed-Cycle, in that routines are carried out in a prescribed sequence. The variable-cyclic approach has been used in many real-time programs; the example considered here will be its use in a message-switching communications system. It will be assumed that the communications interface equipments are of the complex type, in which several incoming messages or parts of messages are buffered in the peripheral equipment until the central processor calls for them (on input), and similar buffering is done on outgoing

# 261 companies have already inquired about applications of the new Omnimod power supply

Most of them were for normal P.S. requirements. A few of you tried to stump us with unique problems. Here's an example:



**PROBLEM:** To use OMNIMOD to supply power to line printer hammers which need 90 volt dc for operation. OMNIMOD is limited to 60 v dc.

**SOLUTION (SHOWN AT LEFT):** We connected OMNIMOD in series with an unregulated supply. OMNIMOD's ability to operate over the range of 2 to 60 v without adjustment or modification, *plus* its rapid response time which compensates for the non-regulated supplies voltage variations made this solution possible.

**FACT:** Very few other power supply regulation techniques could have solved this problem. *None* could have done it at such a low cost. OMNIMOD is ideally matched to the severe load characteristics of high speed line printer hammers because of no-load-to-full-load transient load-handling capability and its inherent current-limiting parameter.

*Tough problems? Sure—we welcome them—and easy ones, too. Write or call us collect. Let us show you how OMNIMOD can solve your problems, too.*

 **CONTEMPORARY  
ELECTRONICS**

128 North Jackson, Hopkins, Minn. 55343 Telephone 935-8481—Area Code 612

**EXTRA SERVICE TO THE DATA PROCESSING INDUSTRY**

CIRCLE NO. 21 ON INQUIRY CARD



### We make this airmover unit,

Vaneaxial gas bearing fan, ultra-high reliability, used in *Minuteman*. Only IMC produces it.



### and this unit,

*The Boxer*®, standard sized, distributor-stocked. Rugged metal frame, our own impeller and motor, moves air economically and reliably.

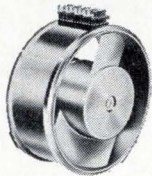

### and this unit,

*Tubeaxial*, the IMCool is distributor stocked in 10 types, inputs of 60, 400, and 1000 cps, air delivery from 18 to 108 cfm.

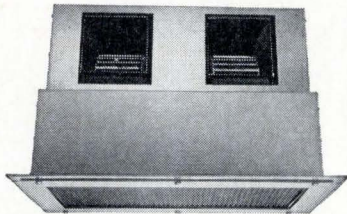

### and this unit,

*Rackmounted double blower*. This one installed right in the broadcast area, delivers 500 quiet cfm to a high-power broadcast transmitter.



### but this unit

## will design and build an airmover to fit your specifications.

IMC is the single-source specialist for airmovers. We design and build the entire system—motor, blade, bearing, housing—and can assume full responsibility in meeting your needs. For quick response, contact Sales Dept., Eastern Division, Telephone (516) 334-7070, or TWX 516 333-3319.

Plants: Westbury, N. Y.; Maywood, Calif.; Rochester, N.H.; and Tempe, Ariz. Products: Airmovers; induction, hysteresis, synchronous, torque, servo, and stepper motors; synchros; solenoids; pressure switches; hydraulic and pneumatic valves; and fuel atomizers. For more data, write:



IMC Magnetics Corp. Marketing Division, 570 Main Street, Westbury, N.Y. 11591.

CIRCLE NO. 22 ON INQUIRY CARD

messages. The Executive Routine calls in the following operational routines in sequence:

- Input data transfer from communications buffer;
- Analysis of incoming messages;
- Transfer of incoming messages to bulk storage (disc or drum);
- Scheduling and selection of outgoing messages;
- Transfer of incoming messages to bulk storage (disc magnetic core storage);
- Checking and possible format conversion of outgoing messages;
- Transfer of outgoing messages to communications buffer.

This sequence is repeated each program cycle. Each of these individual routines takes a variable length of time, depending upon the message load. The time required is minimum when there are no messages to process. The use of a variable-length cycle has a built-in efficiency adaptation. With low utilization of the communications lines (and thus small load on the equipment) the cycle time is short and the overall processing delay on the message in going from communications buffer to disc and out again is also low. However, when the load is high, the cycle time increases, slowing down this overall transfer, but increasing the transfer-volume capacity of the system by taking advantage of the fact that an operational routine can usually process a group of messages faster than the same routine called in twice for processing in separate cycles (two successive pieces of the same message group).

In practice, the particular sequencing of the operational routines will probably differ from that given here to take advantage of certain simultaneous-operation capabilities built into the computer for data transfers. Nevertheless, the particular ordering of operational routines, whatever it is, will not change from cycle to cycle.

**3. Complete Asynchronous Control** — With an asynchronous executive control, there is no cycle as such; operational routines are called in as needed. This form of control is analogous on the macro-level to the micro-level input-output interrupt control where the processor is interrupted whenever an input or output operation terminates, rather than the alternative of a regular continuous scan of the input-output control lines. The ideal asynchronous Executive operates in similar fashion. After the completion of each Operational Routine when the control is returned to the Executive Routine, the Executive looks at the jobs to be done, selects that task of highest priority, and calls in the proper Operational Routine for that task.

The key to this procedure is the **Job List**. This is a simple list (if there are different priority levels, then there should be a list for each level) in which each entry references an operational routine and a piece of data to be used. New entries are made to the list by new input signals to the system and by the completion of other tasks. Thus, each Operational Routine should provide an output to the Executive Routine in the form of a Job List Entry if further work is required.

A possible asynchronous Executive Routine is shown

in Fig. 3. Input-output signals are treated as follows: the termination of an input or output data transfer triggers an interrupt; the routine processing the interrupt makes an entry in a special input-output list which is consolidated with the rest of the job list during the main position of the Executive Routine.

More complex versions of the asynchronous Executive Routine provide for examining the Job List periodically and increasing the priority of tasks held there for an excessive time because of a string of higher priority tasks. In other cases, a mixed or partly-cyclic Executive is often used, with some tasks being carried out asynchronously and others cyclically.

The advantages of the asynchronous approach are that the more important tasks are carried out more quickly; and, because of this, the memory requirement in the processor can often be reduced (this will be discussed further in the next article in this series). The disadvantage is that the lack of program-batching in the asynchronous approach may mean that it can handle less total load.

### Memory Management

The Memory Management Routines are associated with the assignment of memory to the Operational Routines. In simpler systems this may not be necessary; all programs, work areas, and data buffer areas may be given permanent locations in memory. However, in the larger systems, it is usually desirable to have at least a portion of the memory available by different routines during different portions of the overall operation.

In the larger real-time systems, the memory requirements are often such that it is desirable to use a less expensive medium (e.g., tape, disc, drum) for some of the storage. In using such an approach the following general principles should be kept in mind.

- If some programs are to be stored on a drum or disc, then they should be the programs used less often or with less urgency. These programs are brought into a "Surge Buffer" portion of high-speed memory as needed. Obviously, the use of a "Surge Buffer" approach only makes sense when the overall program is easily partitioned.
- If there should be a high data transfer rate requirement between the slow memory and fast memory, as in the message-switch example given earlier, the overall transfer rate capacity can be increased by batching the transfer demands and sequencing these to minimize access time latency. Whether this is worth doing or not depends upon the particular problem.

### Input-Output Monitoring

The details of the input-output processing requirement is, of course, dependent upon both the particular system function and the choice of communications buffering equipment. Normally, however, when the input-output peripheral equipment completes an operation, some quick action is required of the computer program, particularly on input, in order to free the input buffer. Thus, the input-output monitor routine

## a perforated tape reader system for only \$520?



### THAT'S RIGHT!

... only \$520 for the panel mounted Model 1294. And we're mighty proud of the capabilities that permit us to turn out this jewel of a paper tape reader deck at such a low price.

Heart of the system is the rugged NAVCOR 1280 Tape Reader, with its self-contained drive mechanism and extra-sensitive sensing pins. Exerting less than 25 grams of pressure on the tape allows more than 10,000 passes with no tape damage. 5, 6, 7, and 8 level tapes are read asynchronously at 25 cps.

The tape spool servo system is a real beauty. Completely self-contained, it is bi-directional and features automatic forward and reverse, adjustable tape tension, and magnetic braking that insures smooth, silent stops. Transient noise has been completely eliminated through the exclusive design that turns the motor on or off only when the AC waveform crosses the DC zero axis.

Good buy? You won't find a better one. Send in the coupon for the complete story.

### NAVIGATION COMPUTER CORPORATION

Valley Forge Industrial Park • Norristown, Pennsylvania  
Dept. CD-010 • TWX 215-666-0729 • Phone 215-666-6531

## NAVCOR®

Valley Forge Industrial Park  
Norristown, Pennsylvania



SOUNDS LIKE A GOOD DEAL! Please rush me all the technical data on your Model 1294 Reader System.

Name \_\_\_\_\_  
Title \_\_\_\_\_  
Company \_\_\_\_\_  
Address \_\_\_\_\_  
City \_\_\_\_\_  
State \_\_\_\_\_ Zip \_\_\_\_\_  
Dept. CD-010

CIRCLE NO. 23 ON INQUIRY CARD

is often cycled more frequently than the other routines, or it may operate on an interrupt basis. In this sense, the input-output monitor structure is similar to the overall Executive sequences, in that it can be either cyclic or asynchronous.

### System Protection

In the real-time system an important consideration is what happens in case of a failure in the equipment. This may be a transient failure only, or it may require the replacement of a part to repair the hardware. In either case, the real-time system cannot normally tolerate a long down-time or an extensive and involved procedure for reconstituting the system; and thus the designer must consider this problem carefully.

Let us consider first the transient error. The system should have a capability for recovering rapidly following a transient failure. This may be implemented by monitoring a copy of the program in auxiliary storage (tape, disc, or drum), to be reloaded in case of a failure. To provide protection for data, the particular application must be considered. If a loss of data would be serious, a copy of this must also be made. One approach is to copy relevant tables and data from core memory into the disc or drum at periodic intervals. Then, in case of failure, it is only necessary to reconstitute from the last set of copies.

In case of a permanent component failure, the solu-

tion has two stages. Stage 1 involves reconstituting a working configuration of equipment from the working hardware, until the failure is repaired. Stage 2 then involves reconstituting the program and data.

Several different configuration approaches have been proposed for continuing operation after a failure. On one extreme is the complete duplication of all equipment with the back-up configuration normally duplicating the computation or perhaps just receiving periodic reports from the on-line processor. At the other extreme is the multi-memory, multi-processor system where all units normally in operation, sharing the load, and where, in case of a failure, the load is then taken over by the remaining hardware with some tolerable degradation in total performance.

The system must, of course, be designed so that failures will be detected rapidly (by various test routines such as data checks); and so that the faulty component can be readily isolated. In the more complex arrays an important consideration is how to make certain that the faulty hardware is removed from the system, particularly if the faulty equipment is involved in the switching control.

The various details of such systems will not be discussed further here; however, it must be emphasized that the total system, including duplications and recovery procedures, must be considered in the program design, and that the design of the simplex system by itself is often meaningless.

---

# evervolt™

## complete voltage reference units

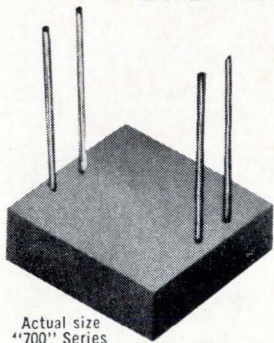

### in modular component size

small ■ printed circuit or chassis mounting ■ simplifies circuit design ■ no temperature compensation needed ■ low price — unlimited variations of voltages, current, temperature coefficient, regulation, output impedance, case and mounting.

**( NOW! )**

Line operated references  
with 0.0001% regulation.  
Write for spec. 200-15

For information—write, wire or phone

**INSTRULAB, INC.**

1205 LAMAR STREET  
DAYTON, OHIO 45404

---

### Conclusions

All real-time programs have a common ground in their structural requirements. These requirements take shape in four major program functions:

1. Executive Control & Scheduling;
2. Memory Management;
3. Input-Output Monitoring;
4. System Protection.

The way in which these functions must be implemented varies with the application. It is highly dependent on the predictability of the load that the system must carry. Protective features are an essential part of real-time program design. Their incorporation in the program must be planned from the start. Their inclusion may impose a substantial price, both in equipment and in program size and performance.

Functional design of programs necessarily involves considerations of the traffic load to be imposed on the system. Methods for analysis of these loads will be discussed in Part 5 of this series.

---

Next in this series —

**Part 5 .....**

**Program Design — Load Considerations**

---

CIRCLE NO. 10 ON INQUIRY CARD



# FIRST SIZE 11 NEO-MAGNETIC NON-CONTACT ENCODER PACKAGES SIZE 18 CAPACITY INTO 1/6 THE SPACE AND 1/4 THE WEIGHT

Litton's new size 11 shaft-to-digital encoder offers a significant size reduction over a standard size 18 magnetic unit of like capacity. It's 84% smaller and 75% lighter. The reductions were effected through a new proprietary technique representing a distinct departure from the conventional "magnetic spot" approach in which ferrite discs are permanently magnetized to create code-symbolizing flux patterns. Now under patent application, Litton's neo-magnetic approach offers complete immunity from external conditions capable of degrading accuracy by altering magnetic patterns or nullifying operation through demagnetization. ■ ■ ■ Output of the new size 11 encoder is 7 through 19 bits natural binary, either decoded or undecoded for time-shared V-scan decoding logic. Resolution is 8

bits per turn. Operating speed ranges from zero to 1,500 rpm with slew rate to 4,000 rpm maximum. Electronics MTBF is conservatively rated at 15,000 hours. Mechanical life exceeds 200,000,000 revolutions. The electronics, available in discrete or microelectronic form and integrally or separately packaged, can be configured to multiplex a number of encoders. ■ ■ Litton's neo-magnetic, non-contact technique also permits other code patterns to be packaged into cases substantially smaller than previously possible. For details, write: 7942 Woodley Avenue, Van Nuys, California. Telephone 213-781-2111. New York: 212-524-4727. Chicago: 312-775-6697. ■ ■ ■ ■

**LITTON INDUSTRIES  
ENCODER DIVISION**

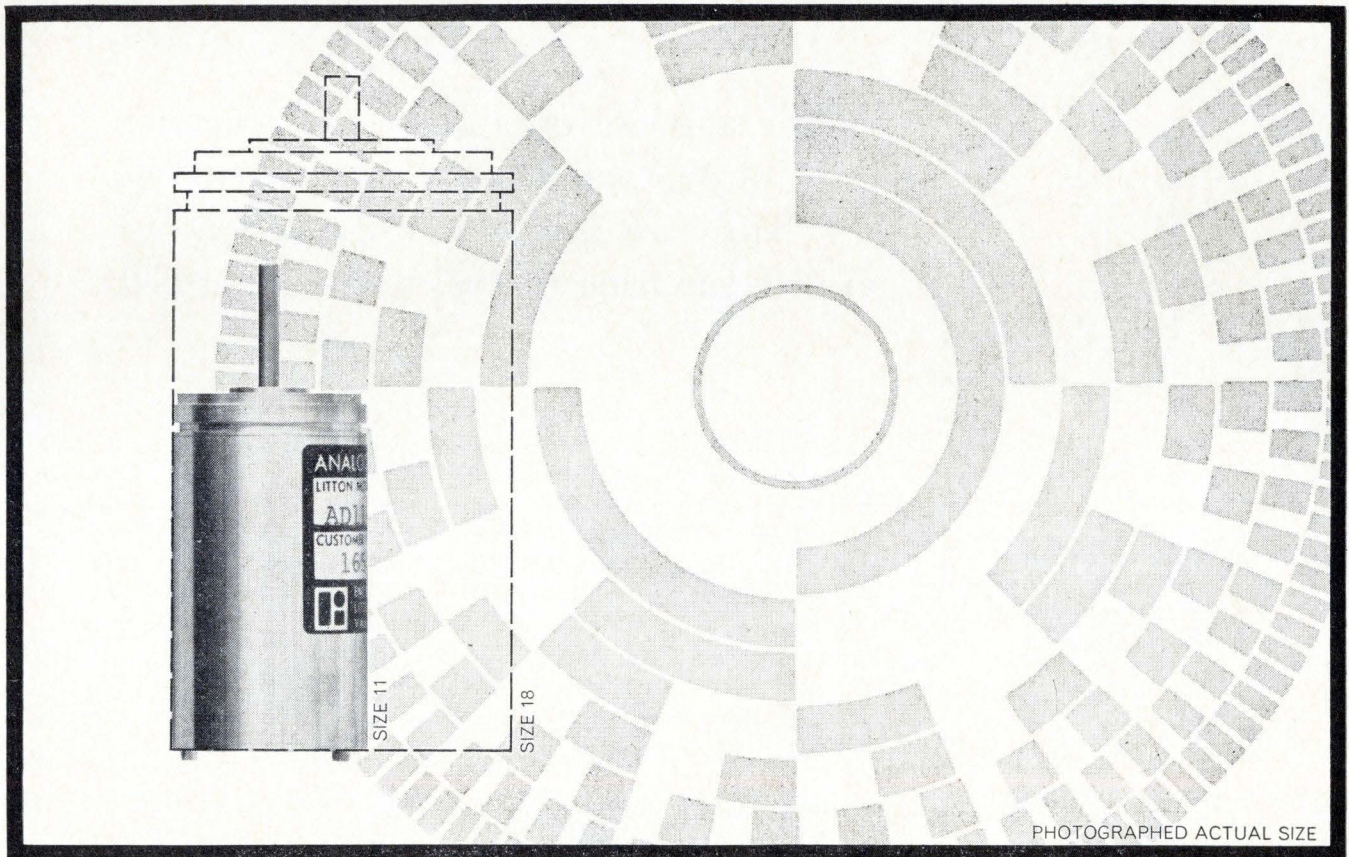

PHOTOGRAPHED ACTUAL SIZE

## Specifications for Typical 13-Bit, Size 11 Neo-Magnetic Encoder

Resolution . . . . .	2 <sup>9</sup> per turn	Diameter . . . . .	1.062 in.
Output Voltage, nominal . . . . .	13 ma @ 4 v; higher if required	Length . . . . .	1.825 in.
Interrogation/output cycle time . . . . .	4.5 usec for parallel decoded word	Starting torque . . . . .	0.05 oz-in max.
		Power consumption . . . . .	700 mw

Optical ■ ■ ■ ■ ■ Solid-State Optical ■ ■ ■ ■ ■ Magnetic ■ ■ ■ ■ ■ Contact

# CONTROL SYSTEM FOR HIGH-SPEED PHOTOCOMPOSITION

With emphasis on a unique combination of digital techniques, the system and hardware approach to the design of a photo-typesetting control unit is described.

**MICHAEL M. STERN,**  
*Mgr. of Systems Design*  
*Di/An Controls, Inc.,*  
*Boston, Mass.*

The National Library of Medicine in Bethesda, Maryland contains the world's largest collection of medical information — well over a million books, journals, pamphlets, etc. The dissemination of this medical knowledge has been speeded up by a giant information processing and retrieval system — Medlars-Grace. Medlars (Medical Literature Analysis and Retrieval System) is a high-speed computer indexing system and Grace (Graphic Arts Control Equipment) converts Medlars' magnetic tape data into photo-copy from which printing plates are made. The system turns out complete pages on photographic film at a rate of 3600 words a minute.

This article describes the major features of the electronic control unit, designed specifically for this

medical data retrieval system, by Di/An Controls of Boston, Mass. The system and hardware approach to the design of this photo-typesetting control unit represents a unique combination of various digital techniques.

Basically, the control unit (see Fig. 1) processes information received from a magnetic tape handler and presents it in a predetermined time sequence to a movable lens-photo recording system. The input-output speed and capacity requirements are determined primarily by the photographic unit which is capable of photocomposing 8" fully-justified lines at approximately 150 lines-per-minute. A choice of up to 256 different characters is available during continuous operation, and any combination of characters can be

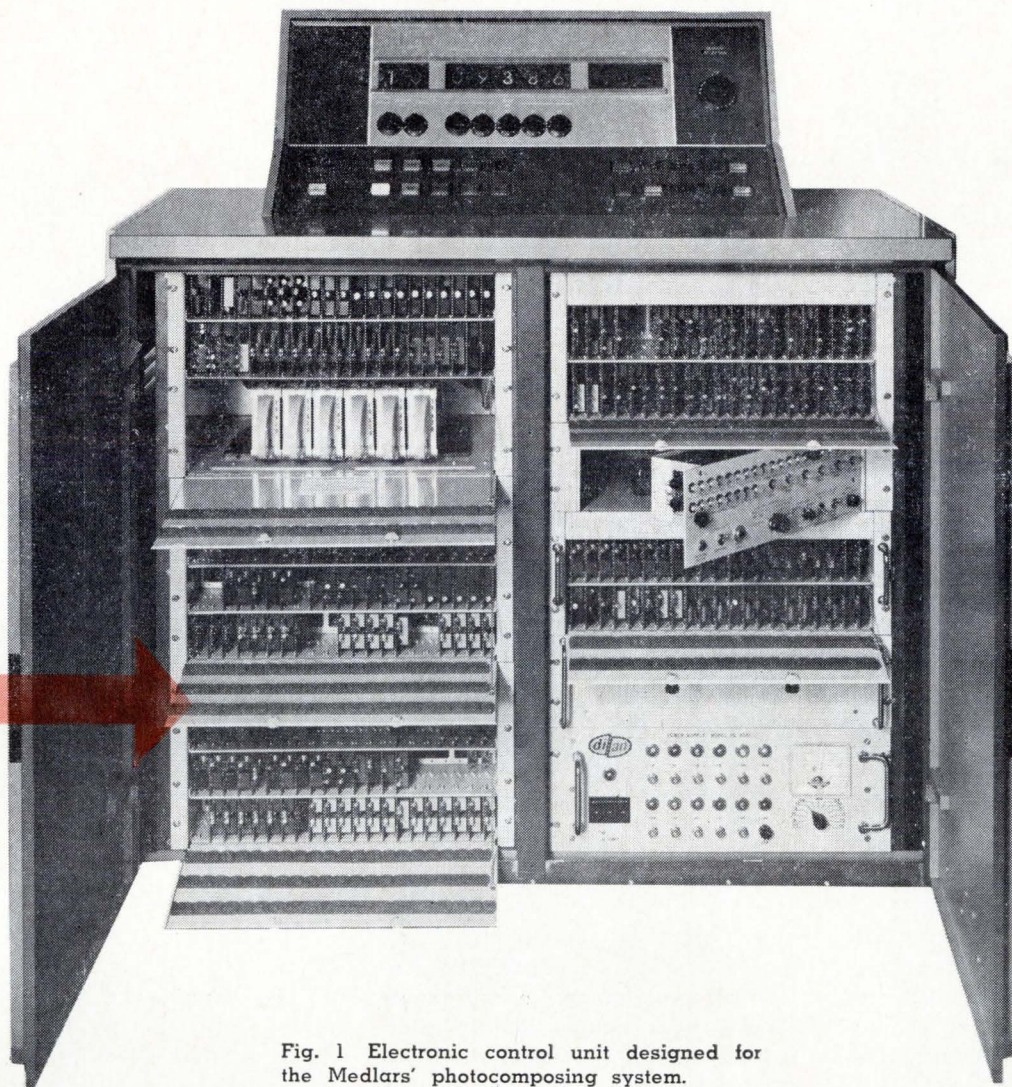

Fig. 1 Electronic control unit designed for the Medlars' photocomposing system.

mixed in the same line. Since the photographic unit can record only one line of print during any one cycle, the control unit processes only a single line at a time. Due to the number of computations which must be made on a single line, and the necessity to present the output information to the photo unit in real-time at a relatively slow rate, the receipt of input information must take place at high speed.

The data information input contains a sequence of characters forming a justified line, presented in the order in which they appear on the printed line. The control information input gives the location of the line with respect to the text to be printed. Timing signals from the photo unit to the control unit are basically a series of pulses refer-

enced to a point physically located at either the left- or right-hand margin of the film to be produced. These pulses indicate the instantaneous position of the moving lens as it traverses the film. A separate voltage level defines the direction of lens travel.

Due to the unique design of the photographic and optical system (Photon 900, manufactured by Photon, Inc., of Wilmington, Mass.), the characters are not flashed on the film in the order in which they appear in the printed lines, but are exposed in accordance with their print position in the line plus a position shift caused by the characters being focused on the film from different angles. The projection of these characters falls on different positions for a fixed position of the

lens system. Thus, the width of each character must be added to all previous character widths in the line in order to accumulate the width of the line. Also, accompanying the identity code of each character must be a computed value that equals the sum of all previous widths in the line plus its position shift value. This value determines at which position (or time) in the movement of the lens system, the character must be presented to the photographic unit. The time during which this coincidence occurs is called the "flash time."

#### Major Operational Modes

To implement the previously-described functional requirements, the data-handling operation is broken

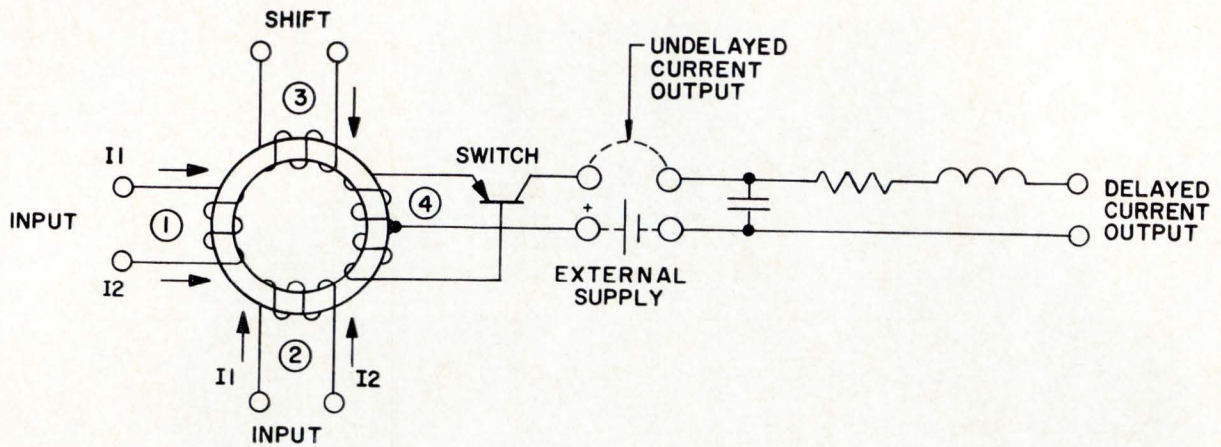

Fig. 2 The core-transistor logic element used in the interface and control logic circuits has high magnetic retentivity with two input windings (1 and 2), one shift winding (3), and one sense winding (4). The input winding always sets the core to the ONE state when driven in the direction of  $I_1$ . The shift winding always resets the core to the ZERO state. The sense winding senses the change of state of the core and a current is produced in the sense winding when the regeneratively-connected transistor is turned ON. The transistor turns ON only during the interval when the core switches from the ONE state to the ZERO state.

The delay network is an RLC network that is fed by the current that flows to the switch while the core is changing from the ONE to ZERO state. The capacitor in the delay network is charged by the sense winding output through the closed switch, while the core is being shifted from the ONE to the ZERO state by the shift current  $I_2$ . There is, therefore, an undelayed voltage output built up across the capacitor while it is being charged. When the core reaches the ZERO state, the switch opens and the capacitor discharge provides a delayed current output pulse.

into four major modes: Load, Calculate, Index, and Transcribe. During the Load mode, the data information and its control characters are fed to the control unit. The flash time of each character is then calculated during the Calculate mode, and the resulting flash time and character identity codes are placed in storage. In the Index mode, the characters are arranged according to their real-time sequence prior to being sent to the output photographic section. In the Transcribe mode, timing signals from the photographic unit synchronize the decoding of the characters and their transmission to the photographic unit. Immediately following the Transcribe operation of one line, the succeeding line of print is loaded from the tape into the input storage and the above operations are repeated.

Because the film cannot be monitored during automatic operation for hours at a time, it is necessary to monitor the system automatically for a variety of possible alarm conditions. Thus, alarm indicators for the following conditions are pro-

vided: film low, flash lamp misfire, film leading error, parity error, input or programmer error, power failure, tape handler failure, internal control error, mechanical interlock open, end-of-tape, end-of-file, and end-of-report.

#### Functional Submodes

In addition to the normal photocomposition function described above, there are four distinct submodes of operation: Search, Proof Copy, Confidence Check, and Record Repeat.

In the Search mode, the complete tape is searched in the forward direction for the report number (2 digits) and page number (5 digits) selected by the operator on switches located on a control panel. This location information precedes each line on the tape. When the first line of the selected page appears, normal composition takes place.

In the Proof Copy mode, an operator command causes the page to be retranscribed onto a fast-developed positive for a check of both system operation and text quality.

The complete operation is automatic.

The Confidence Check mode, when initiated by the operator, loads a pre-selected line and calculates, indexes, and transcribes the line while checking all functions within the system including the exact calculation. Failure of any function causes the Confidence Check indicator to display a three-digit number which pin-points the failure. Completion of the check without failure is visually indicated.

The Record Repeat mode is initiated automatically when a parity error is sensed on tape. The complete record is read a second time with the result that if no error occurs on the second readout, the initial parity error is ignored.

#### Basic Hardware Approach

The hardware used in the electronic control unit comprises a combination of available digital technologies with emphasis on magnetic concepts. Both the magnetic tape interface and the control logic circuits use static transistor configura-

## The creative systems designer and the Bryant PhD-170 were made for each other.

He finds himself with unlimited programming possibilities and a chance to plow new fields in advanced computer applications. The PhD-170 multiple channel drum has simultaneous random read-write access to 21 million bytes. Up to four computer channels provide programming flexibility, redundancy, and the ability to serve multiple processors at the same time. The PhD-170 can be plugged into any make of computer, big or small. What couldn't be done with other random storage devices

can now be done with the  
PhD-170,  
inexpensively.

Just imagine!

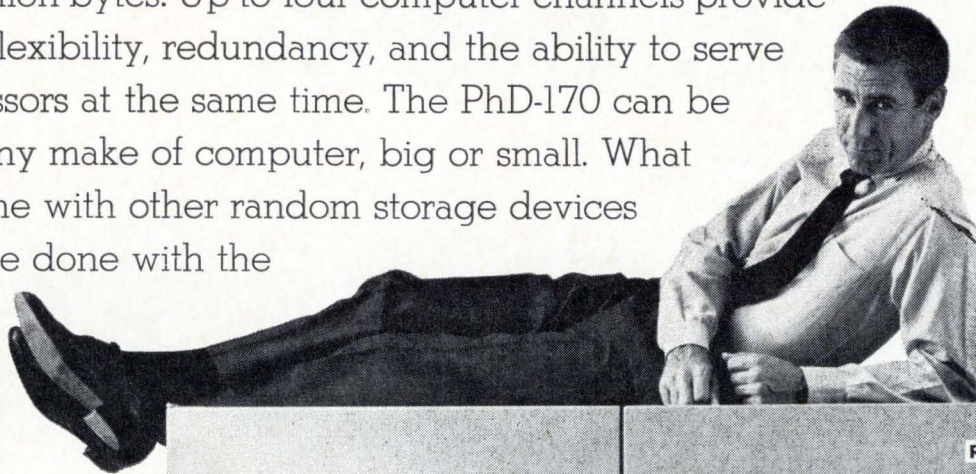

**BRYANT**

**COMPUTER PRODUCTS**

A Division of EX-CELL-O Corporation

850 Ladd Road • Walled Lake, Michigan 48088

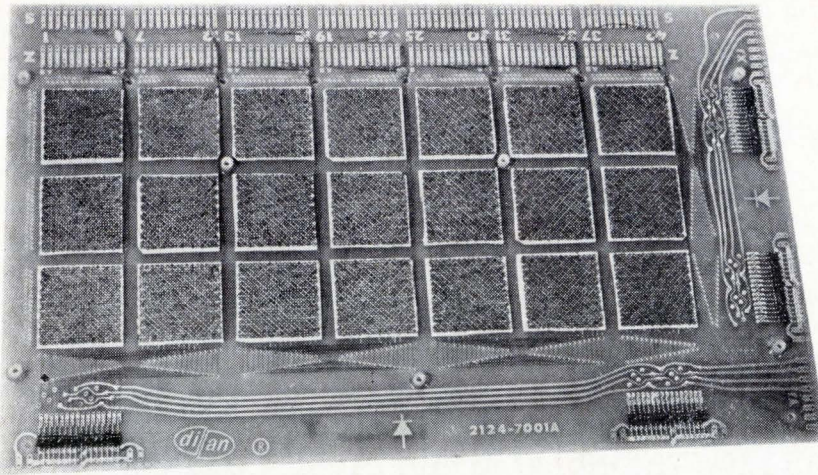

Fig. 3 Memory array was constructed using a straight-through continuous wiring technique rather than a stacked plane technique.

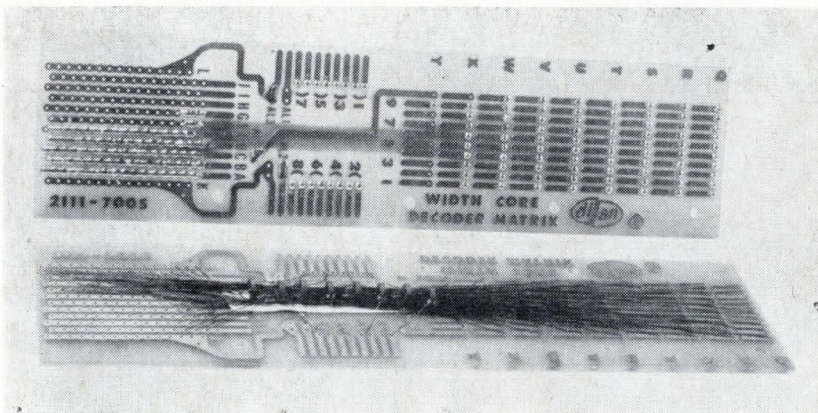

Fig. 4 Plug-in "rope" width-decoder card.

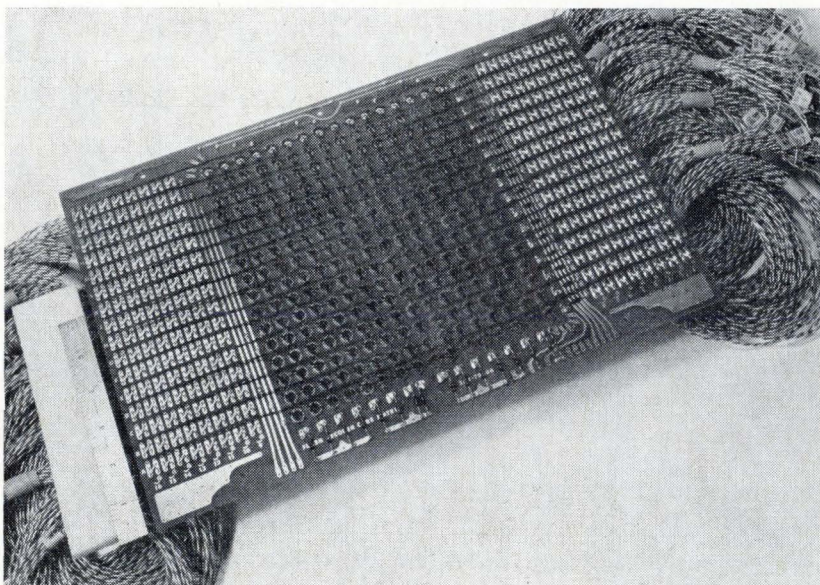

Fig. 5 Flash decoder switch core matrix.

tions. The design of the calculation circuits was based on serial magnetic core-transistor logic (CTL). Data storage is provided by coincident-current magnetic core memories. The look-up tables are implemented with linear-selection "rope" memory techniques. The output decoder section that drives the photographic unit (a single line is used to drive each of 256 flash lamps) was designed around a coincident-current magnetic switch core matrix.

The CTL circuit, as shown in Fig. 2, consists of a magnetic core, a transistor switch, and a delay network. The logic capabilities of the CTL arise from the use of two (or more) input windings. This module performs logic by making use of the input windings either to set the core to ONE or to inhibit the core from changing state. This is accomplished by using currents of appropriate directions or by not using them at all. Both voltage and current outputs are available from the CTL. Voltage outputs are used to activate flip-flops, gates, SCRs, and other voltage sensitive devices. Current outputs are used to shift, input (drive or write-in) and inhibit CTLs and other current sensitive devices. In the Medlars application, the main advantages of this type of logic lie in the use of a single logic element throughout, and the reduction in total circuitry through the use of extremely efficient serial computation.

The Medlars photocomposition control unit contains two coincident-current memory stores — one a 256 word, 20 bits-per-word memory, and the other is a 3072 word, 8 bits-per-word unit. These memories each contain two up-down counters plus an address register for external address input. The following list of some of the memory control functions performed by these units illustrates their unique design flexibility.

- Half-cycle/full-cycle operation
- Enable counter-1/counter-2 or external address
- Reset counter 1
- Reset counter 2
- Preset counter 1 to external address

Send for pre-prints of discuss-only papers before it's too late  
— use order coupon below.

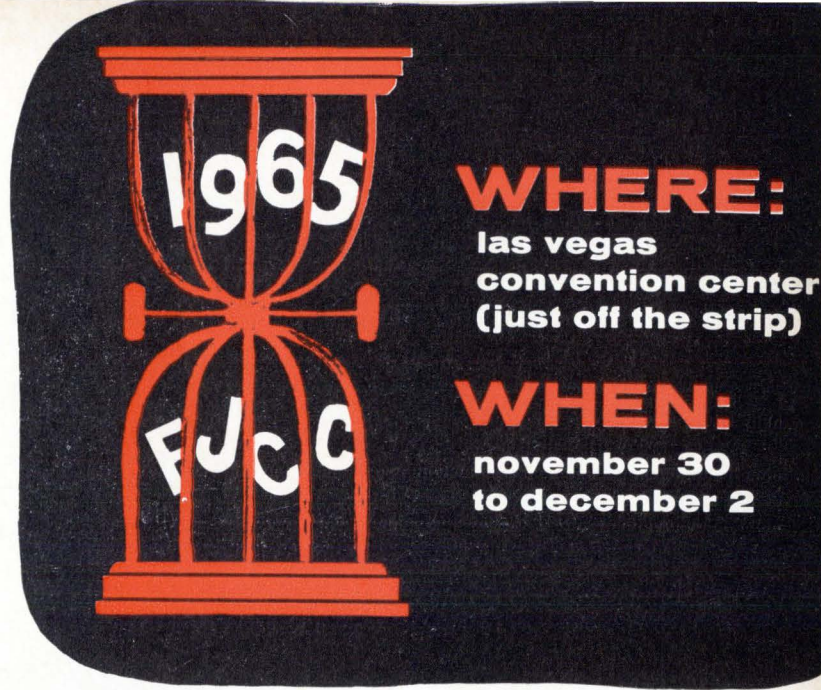

**WHERE:**  
las vegas  
convention center  
(just off the strip)

**WHEN:**  
november 30  
to december 2

## Discuss-Only Sessions at the Coming 1965 Fall Joint Computer Conference

Last month's issue of *COMPUTER DESIGN* gave the details on the 1965 FJCC technical sessions that are scheduled as discuss-only sessions. If you are planning to attend this conference, you should consider participating in one or more of these discussion periods. To do so, you must obtain copies of the discuss-only papers in sufficient time, prior to the conference, to allow critical study of the material.

The titles of the 5 discuss-only sessions are Scratch-pad Memories, Read-Only Memories, Memories for Future Computers, On-Line Interactive Software Systems, and Time-Shared Computer Systems. There are a total of 24 papers involved, contained in a single paper-bound volume that will be mailed on order.

Since delivery time can take as long as two weeks from receipt of order, you should submit your order prior to November 1st. The conference opening date is November 30th and two weeks in which to study the material probably should be a minimum time allowance.

### procedure for participating in discuss-only sessions

To take part in the discussions on any of the papers scheduled for the discuss-only format, you should order the pre-prints prior to Oct. 21, 1965. The mailing of the papers will commence on that date giving you approximately a month's time to study those papers in which you are interested. The complete papers for all 5 discuss-only sessions will be contained in a single paper-bound volume. The cost of this pre-print volume is \$5.00; however, upon presentation of such payment receipt (which you will receive with the volume) at the conference in Las Vegas, you will be charged with only a \$5.00 registration fee. Otherwise, the conference registration fee is \$10.00.

To order your copy of the papers, simply fill out and mail the coupon below with an enclosed check for \$5.00 payable to "AFIPS."

COMPUTER DESIGN  
Baker Avenue • West Concord, Mass. 01781

Gentlemen:

Enclosed is \$5.00 for copy of 1965 FJCC "Discuss-Only" conference papers. I understand that this \$5.00 will be deducted from the \$10.00 registration fee.

SHIP PAPERS TO:

Name .....

Company .....

Address .....

City ..... State .....

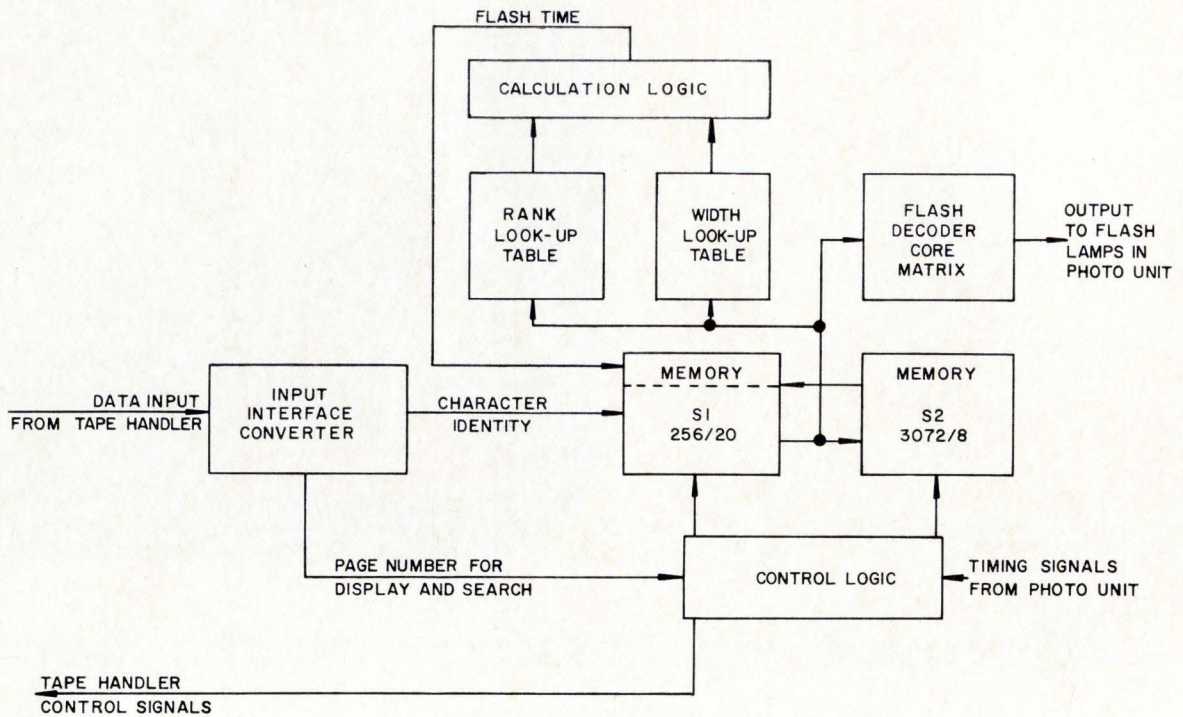

Fig. 6 Simplified block diagram of control unit illustrating data flow from tape handler to photo unit. In the Load mode a single record is read one frame at a time from the magnetic tape handler into the Input Interface Converter. The first six frames of information in a record contain the banner word. The page and report numbers, which are decoded from the banner word, are displayed on the console control panel and are also used to locate particular records during the Search mode. The succeeding information is then converted from Honeywell format to Medlars character code format while parity is checked, and stored in successive addresses in Memory S1 until an end mode control character is received from the tape unit starting the Calculate mode. In the Calculate mode, each eight-bit character is read out sequentially from Storage S1, and used as an address in both the width and position shift look-up tables and the widths are accumulated. The position shift (referred to as the rank) of the character is then added to the accumulated widths of all previous characters in the line, resulting in a numerical calculation of the flash time. The twelve-bit flash time and the eight-bit identity code are restored in their original address in memory S1. At the end of the Calculate mode, all of the characters and their associated flash times stored in S1 have to be rearranged in a way suitable for the Transcribe operation. The requirement that the identity codes come out during the photographic transcription at the real time equal to their respective flash times is accomplished in the Index and Transcribe modes by interconnecting the memories as shown in Fig. 7.

- Preset counter 2 to external address
- Count up/count down
- Set new data/retain old data
- Update section 1 (bits 1-8)
- Update section 2 (bits 9-20)

As shown in Fig. 3, the memories were constructed using straight-through continuous wiring techniques rather than stacked plane techniques. This results in a considerable increase in the reliability due to the minimization of solder joints.

Linear-selection read-only "rope" memories are used as magnetic look-

up tables storing the rank and width values associated with each character identity code. A typical rope card is shown in Fig. 4. A specific requirement of the system was that the width look-up cards be interchangeable such that various fonts could be used within the system. The result was a magnetic rope card, whose printed circuit mates with spring-type contacts. Three complete fonts are present in the system at all times.

#### Magnetic Switch Core Matrix

The final output of the system is an 8-bit identity code occurring at

a particular time within the lens movement, with a particular correspondence to one of the 256 flash lamps in the system. Since the flash lamps require extremely high grid voltages, high-power SCR circuits are used to drive them. To obtain the energy necessary to fire the high-power flash lamp circuits, 256 separate amplifiers would be necessary after decoding the 8-bit character. But, by using a coincident current magnetic switch core matrix to decode and amplify the character identity code, the amount of circuitry was reduced considerably and the control unit electronics was isolated from the high-power flash



**If you ever get tired of waiting for a Remex tape reader to break down, you can always try hitting it**

**with a hammer.** It's not hard to see why more companies buy Remex tape reader and spooler units than any other. They're built to work, work, work. Without making mistakes. The number of moving parts has been kept to an absolute minimum. The solid state circuit has a simplified design. And then there's the rugged, yet precise way these units are put together. You may find yourself looking for a bigger hammer. For details, phone 213 772-5321, or write us at 5250 West El Segundo Blvd., Hawthorne, Calif. 90251

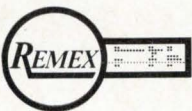
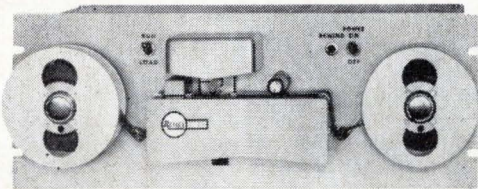
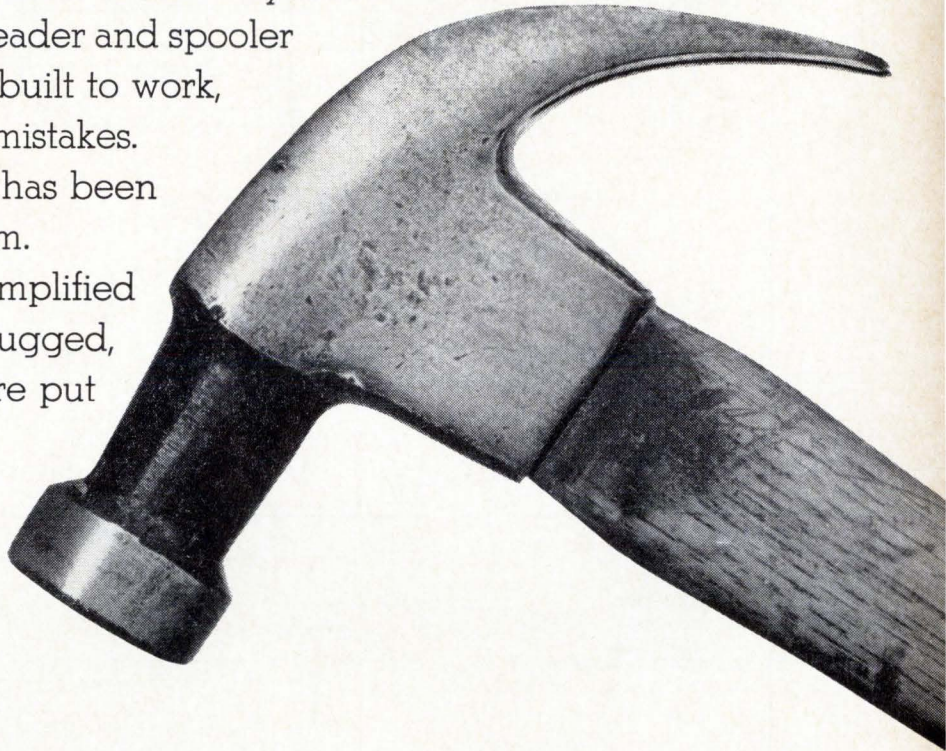

**RHEEM ELECTRONICS**  
a division of  
**EX-CELL-O CORPORATION**

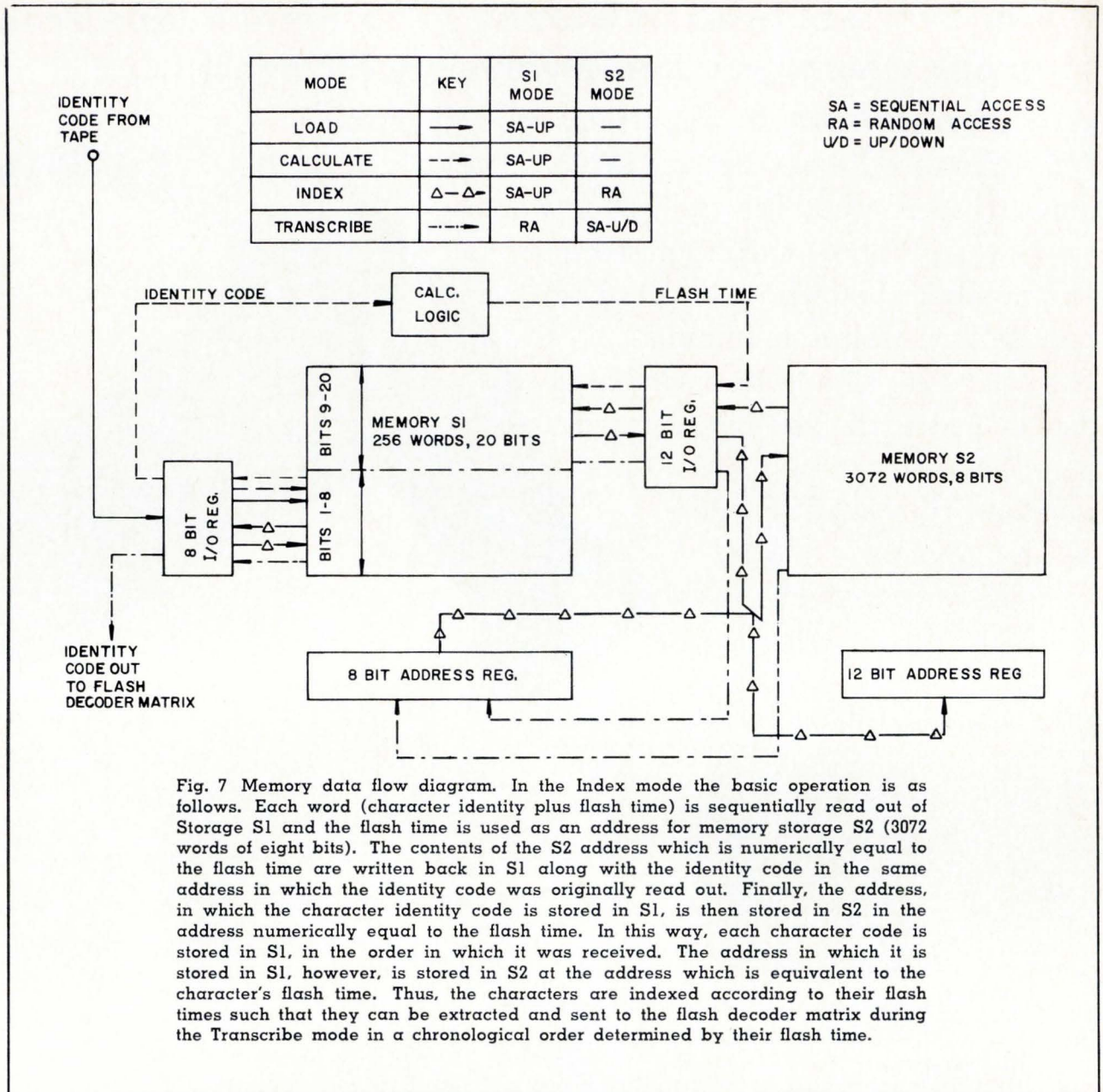

lamp circuitry by the use of double-ended (transformer-coupled) outputs. The flash decoder matrix is shown in Fig. 5. The complete output matrix requires only 16 read-out drivers (four sets of 4), one reset driver, 32 diodes, and 256 ferrite cores arranged in a 16 × 16 matrix.

### System Operation

A detailed system operation is described in Figs. 6 and 7. A simplified block diagram of the flow of data from tape handler to the photo unit is shown in Fig. 6 and the

memory data flow is diagrammed in Fig. 7.

### Calculation Logic Implementation

A block diagram of the Medlars-Grace calculation logic using serial magnetic logic elements is shown in Fig. 8. The calculation logic consists of basically a rank register, a width register, a width accumulator, a half-width accumulator, an output register, two full adders, several gating functions, and two control chains; one for producing the system timing pulses, and one for producing the calculation logic tim-

ing pulses.

One of the more interesting functions provided in the system is the Confidence check function. The Confidence Check logic tests the majority of the system in an instant by entering sequentially, from an eight-bit static counter, all possible identity code and alarm characters into the input interface converter circuitry, bypassing the tape unit. Two deliberate parity errors are forced into the parity check circuitry in order to assure that the parity circuits are operable. At the same time, all other error indicators and alarm conditions are forced to

**EMC INTRODUCES A COMPLETE FAMILY OF 100 KCPS DIGITAL LOGIC MODULES WHICH OPERATE OVER AN AMBIENT TEMPERATURE RANGE OF -55° TO +70°C! HERE IS HIGHEST QUALITY, RUGGED RELIABILITY (OVER 4½ MILLION HOURS MTBF) AT LOWEST COST.\***

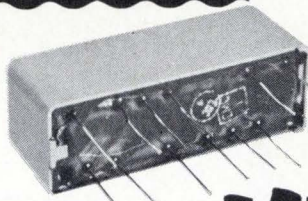
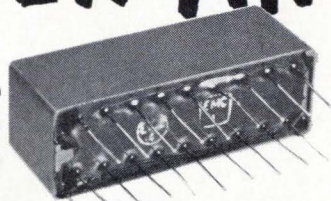
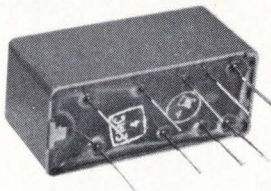

**ELECTRONIC  
MODULES  
CORPORATION**

1949 GREENSPRING DRIVE • TIMONIUM, MD.  
TEL-301-252-2900 TWX-301-252-0723

\* S-R flip-flop module as low as \$3.95 each in quantities of 100.

CALL EMC DIRECT OR CONTACT THE EMC REPRESENTATIVE NEAREST YOU:

**Md., Va., N.C., S.C. & D.C.**  
BARNHILL & ASSOCIATES  
Towson, Md.—(301) 825-3900  
**So. Calif.**  
E. E. ENTERPRISES  
Van Nuys, Calif.—(213) 787-5360  
**No. Calif.**  
E. E. ENTERPRISES  
Palo Alto, Calif.—(415) 324-4448

**W. Pa. and W. Va.**  
AUTOMATED EQUIP. & ENGINEER,  
INC.  
Pittsburgh, Pa.—(412) 931-7616  
**Wash. and Ore.**  
FARWEST AGENCIES  
Bellevue, Wash.—(206) 454-7905  
**E. Pa. and So. N.J.**  
HILLIARD ASSOCIATES  
Jenkintown, Pa.—(215) 884-6100

**Ill., Wis. and Ia.**  
ACTRONIC SALES ENGRG., INC.  
Chicago, Ill.—(312) 286-1037  
**Colo., Wyo., Kan., Nebr.,  
N. Mex., Ut. & Mo.**  
INLAND ASSOCIATES  
Mission, Kan.—(913) 362-2366  
**Fla.**  
LYNCH-GENTRY ASSOC., INC.  
St. Petersburg, Fla.—  
(813) 347-5131

**Ohio, Ind., Mich. and Ky.**  
BERNARD L. MICHAELSON CO.  
Xenia, Ohio—(513) 372-5496  
**Met. N.Y. and So. Conn.**  
PODEYN & SCHMIDT  
Great Neck, N.Y.—(516) 487-1173  
**No. N.J.**  
PODEYN & SCHMIDT  
Wood-Ridge, N.J.—(201) 438-2780

**Canada**  
RYCO ELECTRONICS CO., LTD.  
Quebec, Can.—(514) 695-6236  
**Tex., Okla., Ark., La., W. Tenn.  
& Miss.**  
THE TEXPORT COMPANY  
Dallas, Tex.—(214) 631-6270  
**Minn., N.D. & S.D.**  
COUNTRYMAN AND WAGNER  
St. Paul, Minn.—(612) 645-9925

Modules Potted in TIMONIUM

CIRCLE NO. 28 ON INQUIRY CARD

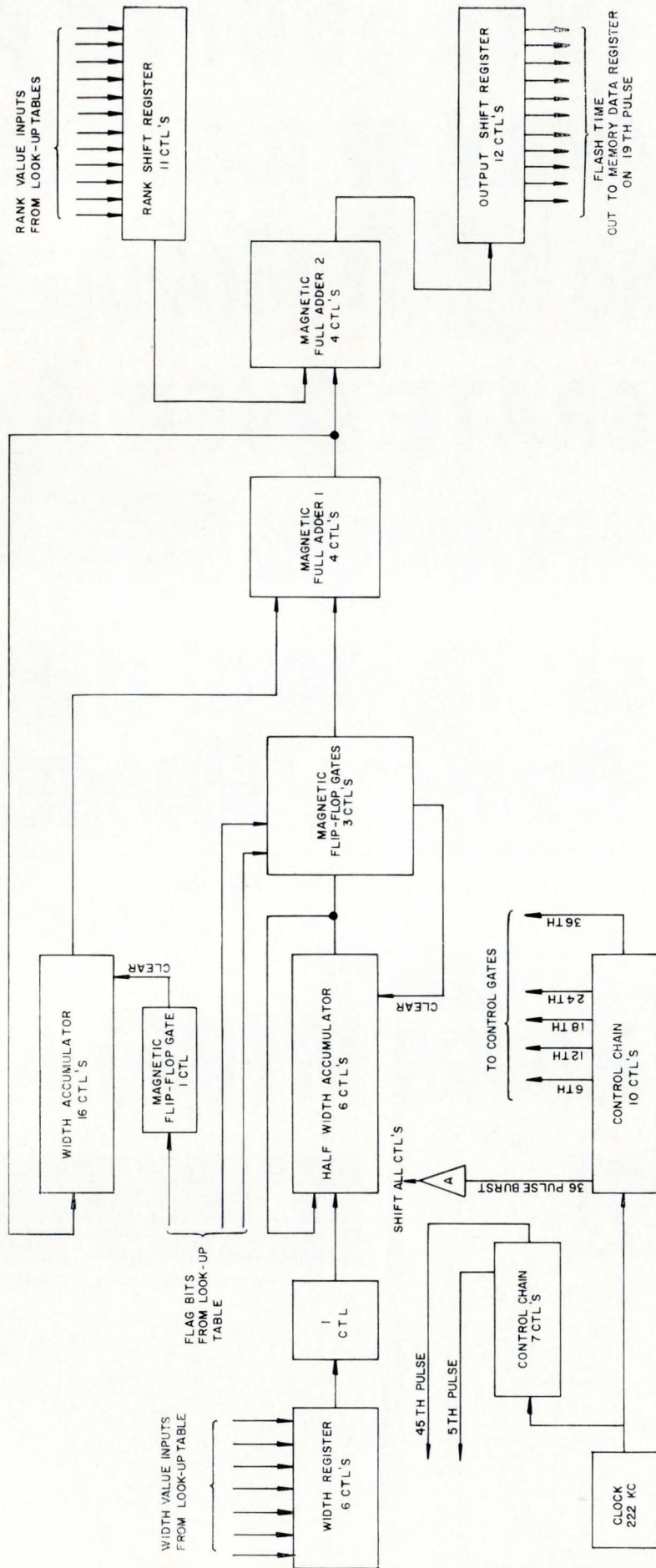

Fig. 8 Block diagram of the CTL Calculation logic. This logic accomplishes the complete numerical computation of each character's flash time using serial addition.

identify their particular error conditions. The system then goes through a calculate mode computing the predetermined line. The line is then indexed in the normal manner and the last computed flash time is compared with a preset number. Finally, the line containing all characters in the system is sent out to the photo-unit in the Transcribe mode and all lamps are flashed. Should any lamp not fire when commanded to do so, or should any lamp fire without a command, the flash error indicator will be lit and the check number which corresponds to that portion of the confidence check (in this case, a particular lamp) is presented to the operator.

It can be seen that with this checking feature, the operator can have assurance at any time that the system is functioning properly. As a further advantage, periodic marginal checking of the supply voltages for the purpose of pinpointing deteriorated components that may cause future error conditions can be accomplished easily. As a final advantage, the confidence check can be used for troubleshooting in conjunction with a maintenance test panel which allows push-button single cycle operation through the Load, Calculate, and Index modes. The twenty-bit I/O register used by both memories plus the eight-bit S1 address register are displayed on the test panel. **END**

# 8 steps to acquiring a better memory...



## \* Disc mass memory, that is.

For "time-sharing" and other applications where various computer systems must draw upon one large-capacity, central memory file designed for continuous and virtually instantaneous information processing, the LIBRAFILE 4800 mass memory produced by Librascope Group of General Precision, Inc., offers many remarkable new features. Consider the following before you buy or specify:

### Step 1. Consider Capacity:

Where an extremely large amount of data must be stored, the memory element of the LIBRAFILE 4800 has an initial capacity of 400 million bits of information with expansion capability to 6.4 billion bits on a single trunk line.

### Step 2. Inquire About Access and "Time Sharing":

The technique of information retrieval used by the random-access 4800 is either fixed-address or record-content search, depending on the master-control electronics used. Average access time is 35 milliseconds. Search by record-content is an exclusive technique that permits any desired field to be used as the access key so that where the data is stored need not be known; only what information is needed. Costly flagging and table look-up are

eliminated and simultaneous off-line search is permitted. The 4800 can be easily incorporated into time-sharing computer networks.

### Step 3. Consider Flexibility:

The LIBRAFILE 4800 mass memory can be used with any data processing system, whether already in use or scheduled to be installed in the future to provide faster, more accurate, more reliable operation with greater storage capacity.

### Step 4. Inquire About High Transfer Rates:

The Series 4800 disc files can be organized to transfer data at rates from 1 million up to 160 million bits per second. This is accomplished through multiple-head read/write operations. (The 4800 discs have one head for every data track.) Through adaptation of special electronics, data rates approaching 1 billion bits per second are possible for special applications.

### Step 5. Ask About The Manufacturer's Experience:

Behind the LIBRAFILE 4800 mass memory is the extensive background and 28-year history of Librascope Group of General Precision, Inc., in computer equipment and components.

### Step 6. Check The Equipment's Performance Record:

LIBRAFILE 4800 mass memories are a key part of a General Precision/Librascope data processing system in Headquarters USAF's 473L command-and-control system in the Air Force Command Post at the Pentagon. More than a million headbar hours have been logged without a single head-bar failure. And, a scheduled installation for a scientific laboratory will provide a common data base for eight powerful computers, enabling many scientists and engineers to "share" the system on virtually a simultaneous basis. The 4800, in this instance, will help replace magnetic-tape equipment twelve times more costly and which must now be manually monitored to provide the data base.

### Step 7.

#### Request Detailed Information:

Write today for our brochure showing applications, typical configurations, and complete specifications.

### Step 8. Call or Write Us:

The quickest and surest way to acquire a better memory (a LIBRAFILE 4800 mass memory) is to contact our Marketing Department. The address is shown below.

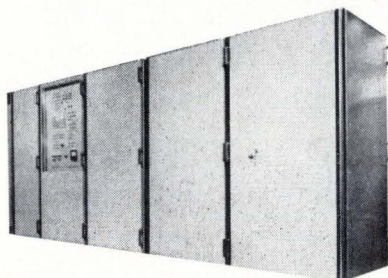

SYSTEMS DIVISION

**GENERAL  
PRECISION INC.**

LIBRASCOPE GROUP

808 Western Ave Glendale 1, Calif.

Phone: (213) 245-8711

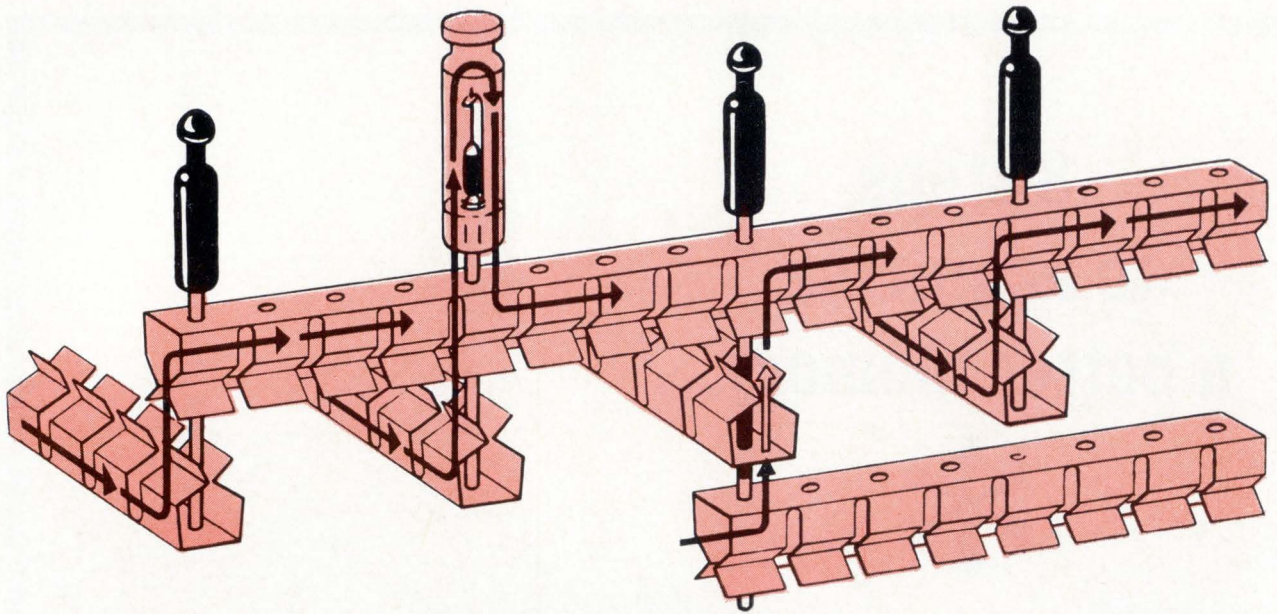

Fig. 1 Matrix boards consist of multiple vertically-stacked planes of contact strips running at right angles to each other, forming an electrical X-Y matrix.

Matrix boards consist of several rows of insulated multi-socket contact strips placed at right angles in multiple vertically-stacked planes. These alternate X and Y planes and strips form an electrical X-Y matrix as shown in Fig. 1. Terminations for each contact strip are brought out through the bottom of the assembly for connection to associated circuitry. The entire contact assembly is sandwiched between non-conductive boards with the top board, or a panel, providing insertion holes at every intersection of the X and Y coordinates. Fig. 2 illustrates how 5 inputs may be connected to any of 5 outputs with a typical 5 x 5 matrix board.

# PROGRAM/SWITCH MATRIX BOARDS

JAMES MULLEN and HOWARD F. GORDON

Sealectro Corp., Mamaroneck, N.Y.

As an alternative to patchcord systems, the matrix board and pin system is finding increasing applications in many areas. However, it is generally not considered as an alternative to paper tape programming. Yet, as reported in this article, the matrix board system of programming machine tool functions has been gaining wide acceptance overseas. Here is a brief review of how these boards function, their advantages as compared to patchcord methods, and examples of machine tool control applications in Great Britain.

## Matrix Boards vs. Patchcords

Patchcord systems require connections to be made from input to output with jumper wires. A large number of these inter-connecting jumper wires frequently results in a confusing array of cables criss-crossing the board. In contrast, matrix boards permit the connections to be made below the board, with only the pins rising above the surface. Also, with the matrix board arrangement, one input can be connected to one or more outputs, and, one output can be connected to one or more inputs; this cannot be done with a system of patchcords.

Patchcord systems with few inputs and outputs are not difficult for semi-skilled operators to handle. They can juggle the limited number

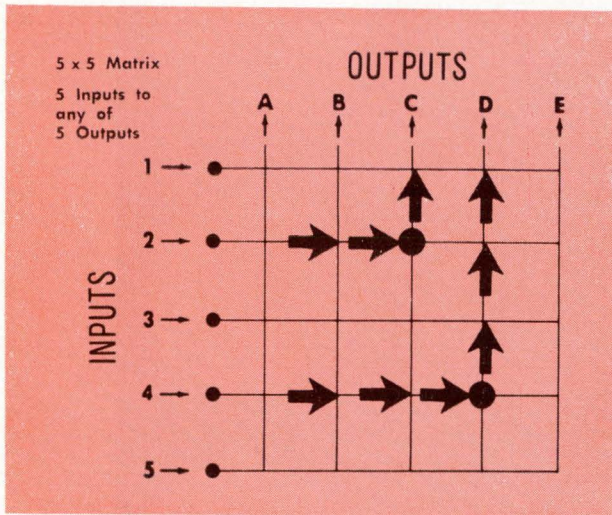

Fig. 2 Five inputs may be connected to five outputs with shorting pins as shown in this diagram of a typical two-deck, 5 x 5 matrix board made by Sealectro Corp. If the shorting pins are replaced with component holders containing diodes, the same basic matrix can be converted to a decimal-to-binary conversion matrix or to an input AND gate. Also, proper logic connections from registers or counters at the input and output terminals will allow miniature lamps (placed in component holders) to be inserted at the matrix intersections as a means of providing information readout.

of jumper wires into the correct holes. But, as the number of jumper wires increases to more than 10, the programming job gets more complicated. When the number of cables exceeds 30, the job of plugging the correct wire into the right hole may be beyond the capability of an untrained programmer. When the number of interconnecting cables exceeds 100 a trained and seasoned programmer must puzzle his way through the job. The job of putting the correct pin into the right hole on a matrix board is much simpler. As shown in Fig. 3, a matrix board system with 18,000 holes was engineered and installed by American Communications Corporation as part of the Hilton Hotel organization's international reservation system. It is programmed and continuously updated by a young lady without professional training. The earlier patchcord system required the services of two professional programmers to keep the system updated.

While the price of a patchcord system is usually less than the matrix board system, the cost of either system, particularly in more complex applications, is only a small percentage of the overall cost of the entire equipment.

### Machine Tool Programming

Here in the United States, machine tool companies automate their equipment primarily with paper tape programming. However, the matrix

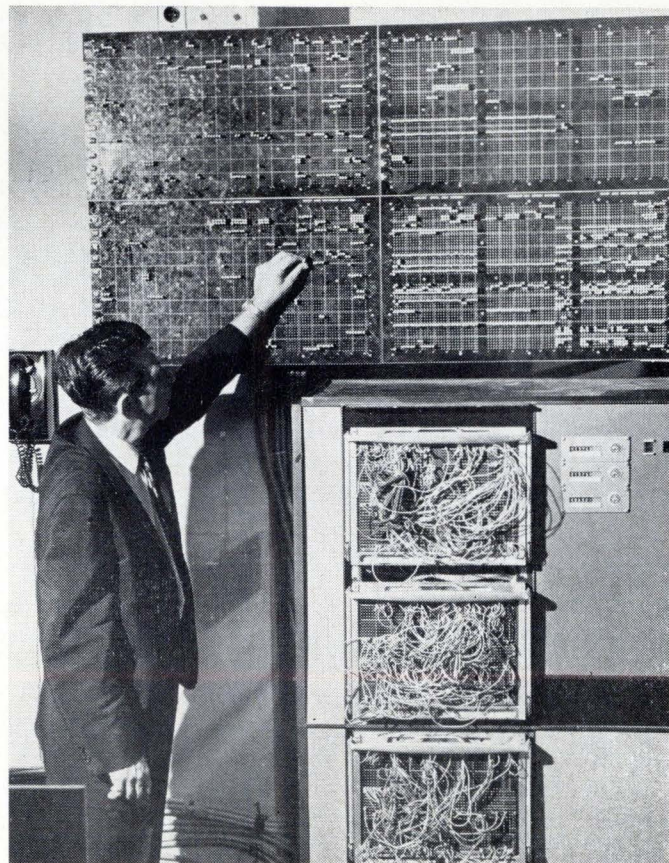

Fig. 3 Matrix board system recently installed at the Hilton Hotels' international reservations center in New York stands above the earlier patchcord system.

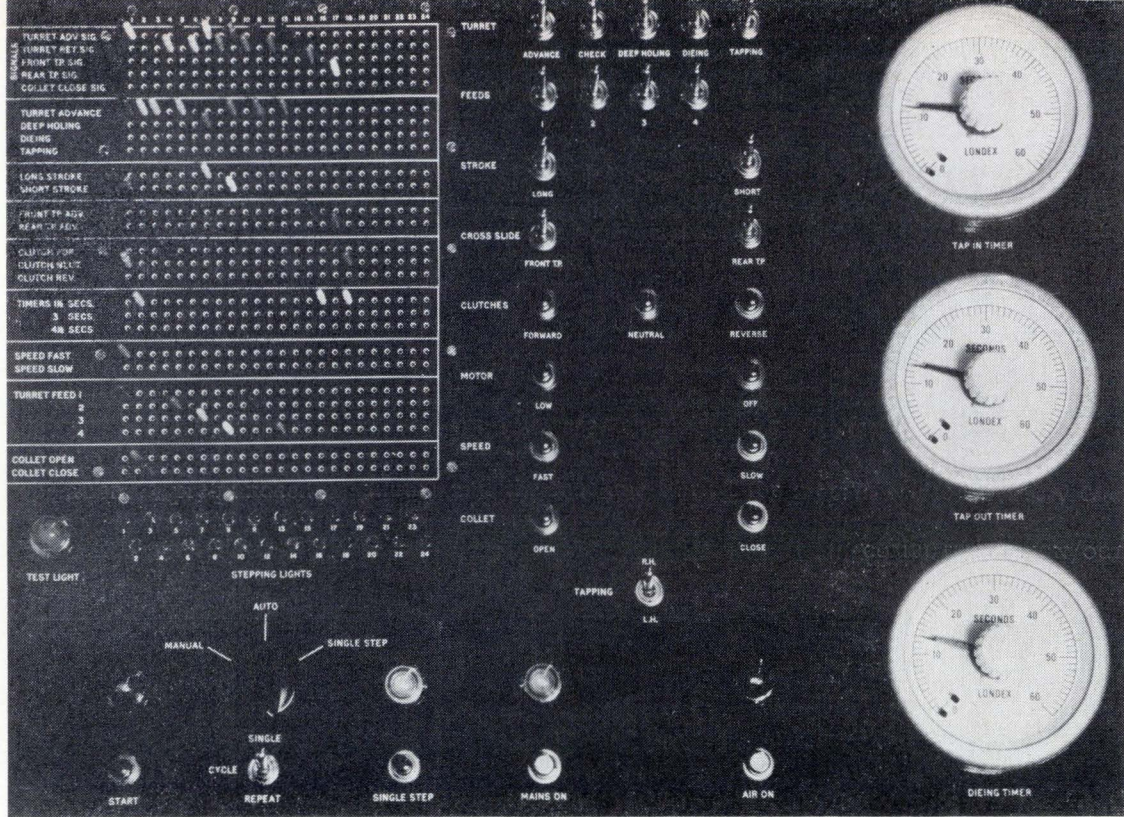

Fig. 4 Capstan lathe controller features matrix board programming at left, as well as switches in the center to control all mechanical functions manually.

board system of programming machine tool functions has gained wide acceptance overseas during recent years and it is now employed with marked success by a number of well-known British companies. One typical example is the Herbert 2D capstan lathe fitted with Auto-Robot control for all machine movements. The matrix board designed for this lathe has each horizontal row representing a machine function, and the positions of the pins in the board determine the relative points in the cycle at which the various functions are obtained. The inserted diode pins connect appropriate circuits which, when scanned successively by a rotary selector switch, actuate air or hydraulic cylinders. Or they may actuate electric clutches and brakes that are attached to the machine elements.

The matrix board is employed for all functions including speeds, feeds, direction of spindle rotation, slide movements, profile attachments, dwell periods, and tool withdrawal before the slide returns. Tools and slide movements can be overlapped to reduce cycle times and the most suitable speeds and feeds can be programmed to extend tool life.

As a guide for the machine setter in plugging in the correct pins for a specific operation, pre-punched

rigid masking templates can be superimposed over the matrix board. These templates can be retained as records of any settings that may be required at a later date, in the event that the machine must be reset.

Another example is a line of matrix board programmed capstan lathes manufactured by H. W. Ward & Co., Ltd. The matrix board controllers are made by Gearaide, Ltd. As shown in Fig. 4, symbols referring to the various machine tool functions are engraved on the left side of the matrix board. In addition to pin programming, provision has been made to control manually all of the machine's functions when it is being set up for operation. During the set-up period, a control knob is set to "manual". After the machine is set and pins have been inserted into the matrix board, the control knob is turned to "single step". On pressing the "single step" button switch, all functions for which diode pins have been inserted in the first vertical row of holes on the board will operate. On pressing the button a second time, all functions plugged in the second vertical row will function, and so on until the complete plugged program has been checked. The control knob is then switched to "auto" and the machine started for

continuous production.

The cross slides are operated by pneumatic cylinders which are controlled by hydraulic cylinders. The slide advances rapidly under air pressure up to a predetermined point near the workpiece, when the slide advance comes under the control of the hydraulic cylinder at the required feed rate. A single control knob sets the feed rate.

The turret forward movement is similar, advancing quickly under air pressure to a predetermined position in front of the workpiece from which point the advance is controlled hydraulically. Four separate hydraulic feeds are provided, each one variable by setting the control knobs.

The first turret station is set to the desired cutting and chip removal by feed no. 1, when a pin is inserted into the matrix board at "feed no. 1" at the position for that turret operation on the matrix board. If a different feed is required for turret station no. 3, then feed no. 2 is used for this station. If the feeds set for turret positions 1, 2, or 3 are satisfactory for other turret stations, it is only necessary to plug in those operations against the number of feeds that apply on the matrix board.

Circle No. 104 on Inquiry Card



# B-L 120 Microfilm Printer/Plotter



## FIRST SECOND GENERATION CRT MICROFILM PRINTER/PLOTTER ON THE MARKET TODAY

The B-L 120 is a truly expandable, modular system, completely **solid-state** and features the latest in high reliability silicon logic circuits.

- Truly off line—does not require expensive computer tape transport
- Through-put—120 frames per minute for both 556 and 800 bpi tapes
- 64 character selection with 128 character option
- Vector line drawing and axes line drawing
- Handles either 16mm or 35mm monochromatic film
- Tape transport compatible with all 7-track, 1/2-inch magnetic tapes or 9-track, 1/2-inch magnetic tape
- Optional "Quick-Look" hard copy-exposure simultaneous with film

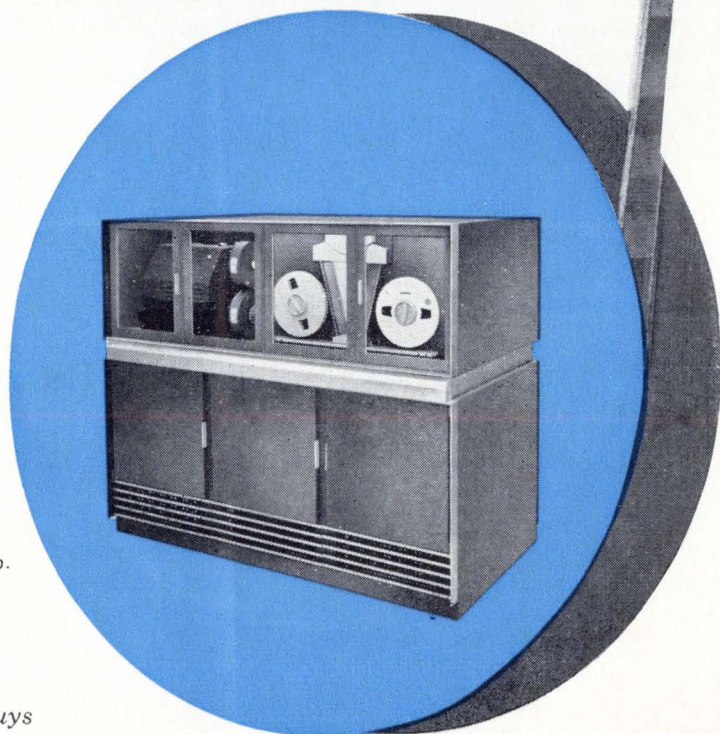

**benson-lehner** corp.

14761 CALIFA STREET  
VAN NUYS, CALIFORNIA

• 781-7100 •

*Demonstrations Now Being Conducted at Van Nuys*

CIRCLE NO. 30 ON INQUIRY CARD



## NEW PRODUCTS

### PROGRAMMED PULSE GENERATOR

Selection of external resistance values is said to provide economical, automatic control of pulse duration, rise time, fall time, and baseline offset for a new programmed pulse generator. High-speed component test, such as test of integrated circuits, can be conducted through use with accessory equipment and card readers, punched paper tape, or magnetic disc programming. Pulse parameters can be set automatically within 2 millisecon of program change, ensuring reliability of test results, greatly reducing testing time, and eliminating the need for highly-skilled operators. Main pulse rise and fall times are continuously and independently variable from 5 nanosecon. to 50 nanosecon. Baseline offset is variable from +2v to -10v on positive pulse and from -2v to +10v on negative pulse. Programming resolution is essentially that of the external programming source. Price of the generator is \$1680. Datapulse Inc., Inglewood, Cal.

Circle No. 144 on Inquiry Card

### TRUE RMS DIGITAL

New instrument permits true rms voltage measurements of complex waveforms. It features precise and easily readable measurements from 1000v ac down to 0.1 volt ac, all within 1% of the indicated value on its 3-digit numerical readout. It uses a "digital passive scaler" system for direct true rms measurements; thus it does not require the care usually associated with delicate thermocouple devices. Basic frequency response is 10 cps to 100kc, through 10V, within 1%. The extended frequency response is 1 mc, within 5%, to provide for broad crest factor utilization and excellent pulse characteristics. Incorporated is a dc voltmeter covering 0.1 to 1000v which is also within 1% of digital indication. Both functions include a fail-safe resettable protection system to protect all ranges automatically against overload up to 1000 v ac/dc. Price of instrument is \$295. Western Reserve Electronics, Cleveland, Ohio.

Circle No. 143 on Inquiry Card

### BAR GRAPH GENERATOR

New generator provides a graphic display of 8 separate input signals in the form of a series of vertical bars, the height of each being proportional to the associated input voltage. Controls allow the positioning and spacing of bars for best display efficiency. Data may be mixed with normal TV images, and two or more units used in parallel when additional bar groups are desired. Individual channels may be readily distinguished, and groups identified by size, location, or video polarity. Price of Model 101 is \$1250. Colorado Video Inc., Boulder, Colo.

Circle No. 126 on Inquiry Card

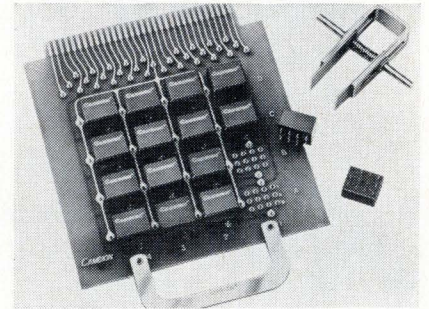

### COMPUTER CARD

New printed circuit card was designed for logic and amplifier modules. The cards are available in two types, CC-01-1 and CC-01-2. Both mount up to 16 modules of 12-pin configuration which include 2mc silicon modules, 100kc germanium modules and 10mc modules. Logic types of all three lines can be intermixed on each card. In the CC-01-1 version, each socket section on the module side has 12 combination jacks with I. D.'s for 0.025" pins. The opposite ends of each of the 12 combination jacks, on the reverse side of the card, have I.D.'s for 0.040" pins for patchboard programming. All other connections on the reverse side of the card are jacks with I.D.'s for 0.040" pins. To insure insertion of proper card into chassis, each card can be keyed by slotting a specific finger of the connector contact area. Cambridge Thermionic Corp., Cambridge, Mass.

Circle No. 128 on Inquiry Card

### NUMERIC READOUT

Characterized as the smallest available numeric readout with a life cycle of 300,000 hours a new numeric readout is a compact correlation of seven microminiature incandescent lamps and seven optical elements. Features include white, bright, sharp display, 170° visibility without loss of readability, low power input capability, and a design simplicity that requires only 7 driver

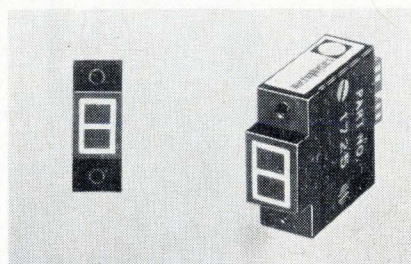

elements. Microphysics, Inc., Westbury, L. I., N. Y.

Circle No. 150 on Inquiry Card

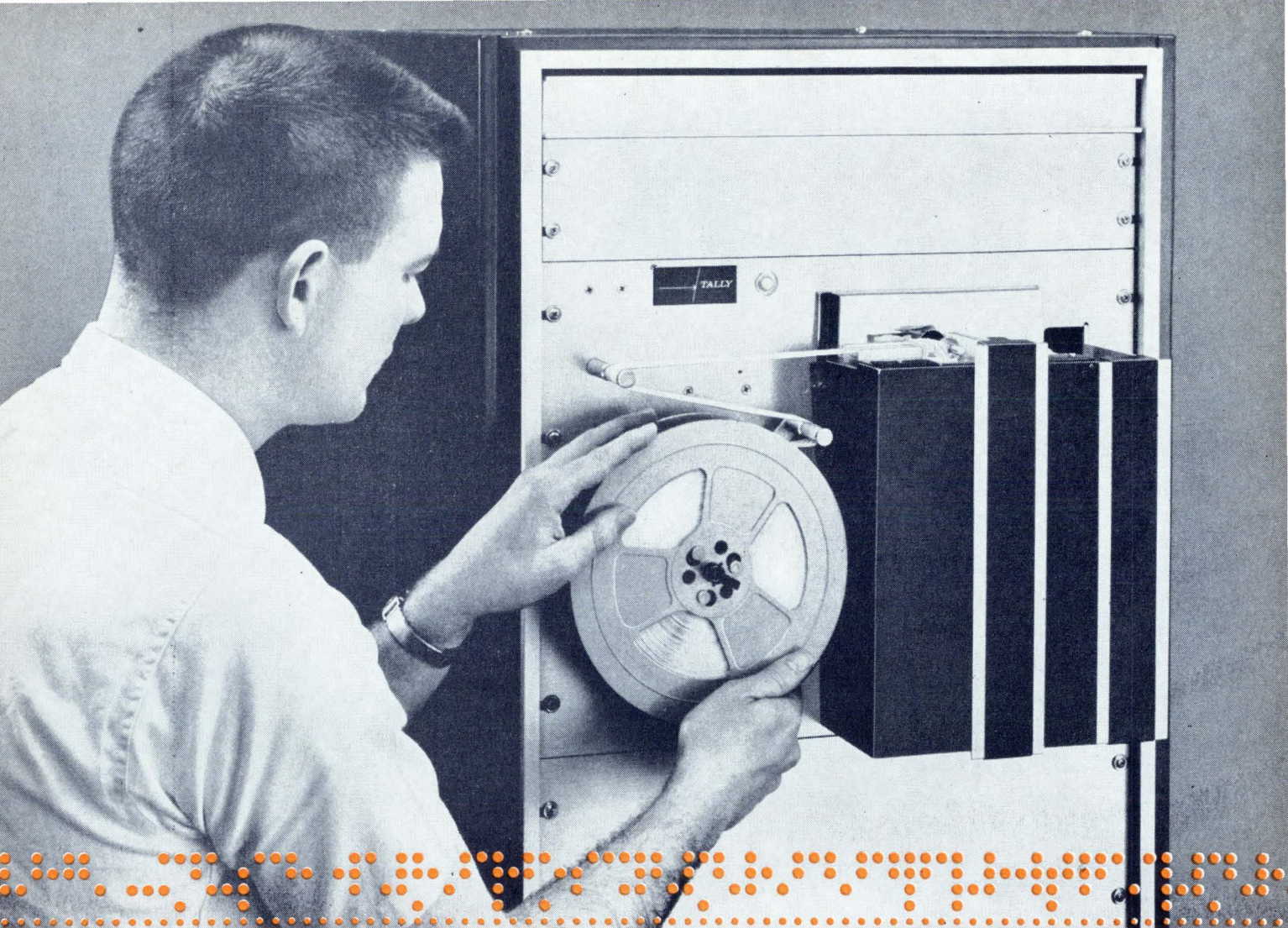

# NEW P-120 PERFORATOR...

... puts down data at 120 char/sec,  
catches errors,  
and prices out at \$975 in quantity

Once in a while, a new product comes along which fits the functional needs of a market to a "T". Tally's new P-120 Perforator is just such a device. The P-120 embodies more useful features and better performance specifications than any perforator ever offered at this price (or even several times the price).

This compact, panel-mounted perforator features integral tape supply and take-up reeling.

The P-120 is designed for quick, easy, front tape loading. Using a limited number of moving parts in a highly accessible frame gives exceptional reliability and speeds maintenance. Operation is asynchronous. Error control and remote tape backup options are offered at modest extra cost. Error checking is accomplished by contacts which

sense the mechanical motion of each punch pin. If an error is sensed, a delete code can be punched **before** the tape advances.

A new bulletin, yours for the asking, tells all. Write our Mr. Ken Crawford, Tally Corporation, 1310 Mercer Street, Seattle, Washington 98109. In Europe and the U. K., address Tally Europe Ltd., Radnor House, 1272 London Road, London S.W. 16, England.

 **TALLY**

## NEW PRODUCTS

### DIGITAL DATA CONVERTERS

Separate transmit and receive modules are said to provide the complete serial-parallel conversion, synchronization, and clocking required between digital data processors and a variety of Datasets and Teletype machines for 5, 7, or 8 data bits. Operating from 60 speed Teletype to 4800 bits/second, the Model ML-100T transmitters accept parallel data within EIA levels for 5, 7, or 8 bits. Five level units output standard baudot code with either 1 or 1½ stop bits. Output will drive a mercury line relay or EIA dataset. An internal line relay is optional. Seven and 8 level units generate ASC code with 1 start and 1 stop bit for 7 level and 2 stop bits for 8 level.

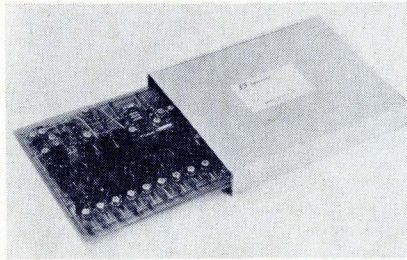

Full compatibility with Dataphone models 103 and 202 and most Teletype machines is provided. The Model ML100R series of receivers accepts serial input from the transmitter, Teletype, or EIA modem sources in baudot or ASC format. Output is a parallel 5, 7, or 8 bit character from an externally selectable store. Control circuits for both units are specifically designed to flag and load from digital computer I/O buffers. Data rates are customer specified and timed from a stable internal clock. Western Telematic, Inc., Pasadena, Cal.

Circle No. 154 on Inquiry Card

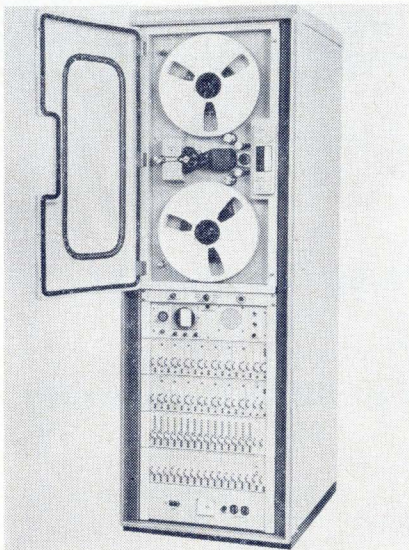

### PCM TAPE RECORDER

A high density, sixteen-track, parallel pulse code modulation magnetic tape recorder/reproducer was originally developed to meet NASA specifications in connection with satellite telemetry data storage systems. It is now adaptable for use as a general data storage facility where a buffer process is required, or as a perma-

nent means of computer output data storage. Recordings can be made with limited bandwidth signals in PCM format at low speed and then reproduced at high speed for computer input. Tape speeds for record/reproduce are 1-7/8, 3-3/4, 7-1/2, 15, 30, 60, and 120 ips (other speeds optional), selectable by switch from either local or remote location. The unit has an adjustable search speed 60-180 ips or a fixed search speed of 120 ips  $\pm$  5% which allows for rapid retrieval of recorded information. In drive mode, transport attains accurate tape speed of 120 ips  $\pm$  0.25% with a full reel of tape in less than six seconds after start. Stop time is less than 1 second at 60 ips and 2 seconds at 120 ips. Constant tape tension is maintained in all modes of operation on both the supply and take-up sides by completely independent, closed loop, electromechanical servo systems. Constant tape tension is also maintained in the start, stop, transitional and fail-safe modes of operation. Telectro Ind. Corp., Long Island City, N.Y.

Circle No. 153 on Inquiry Card

### CAPACITOR CHIPS

Uncased chip capacitors in voltages of 25, 50 and 100 are rugged, nearly monolithic blocks of ceramic dielectric and metallic plate laminated into extremely dense units. The high ratio of capacity-to-volume is said to allow unusually small sizes suited to hybrid circuitry. More than 30 physical sizes are available as standard units, with custom physical shapes and sizes available on special order. Hi-Q Division, Aerovox Corp., Olean, N.Y.

Circle No. 163 on Inquiry Card

### LC DELAY LINES

In designing a new series of lumped constant delay lines, emphasis was placed on high package density and low attenuation to satisfy needs of commercial computer and communications manufacturers who seek accuracy and reliability in small packages. This series offers a variety of time delays, taps and impedances, with delay-to-rise time ratios ranging from approximately 6:1 to 133:1. The epoxy enclosures of these lines are said to provide excellent environmental resistance at minimum cost. Andersen Laboratories, Inc., W. Hartford, Conn.

Circle No. 187 on Inquiry Card

### SOLID TANTALUM CAPACITORS

A new series of rectangular solid tantalum capacitors which can be installed in virtually any position facilitates high density packaging in modular assemblies. The new capacitors are available with axial or radial leads and are said to offer a wide range of capacitance-voltage ratings with extremely low leakage current and dissipation factor limits. Dimensions of the capacitors are 0.125 x 0.070 x 0.040 inches. Capacitance ranges from 1.5 microfarads at 2 volts to 0.0047 microfarads at 20 volts. The maximum leakage current is 0.5 microamps and the maximum dissipation factor 0.10. Tansitor Electr., Bennington, Vt.

Circle No. 166 on Inquiry Card

## HLTTL INTEGRATED CIRCUITS

A complete line of commercial HLTTL integrated circuits are available in the 8 pin short-cap TO-5 hermetically welded package and what is claimed to be the industry's lowest prices for HLTTL circuits. Units are supplied as a standard to a +15 to 55C temperature range but can also be supplied in various temperature ranges up to -55C to +125C with associated price increases. Same chips are used for this series as used for the prime military temperature range units in flat packages. Circuits are produced separately from the standard line and therefore, full, typical distribution of parameters are attained rather than fallout distributions usually observed on commercial type circuits, according to the company. Some of the characteristics that are guaranteed over the temperature range are a fan-out of 7 on standard gates and flip-flop, 20 on the line driver, and 48 milliamps output current on the lampdriver; a propagation delay of 25 nanoseconds maximum (fanout of 1); noise immunity of 300 milliwatts minimum, 800 milliwatts typical; logic voltage swing of 2.1 volts minimum; and a flip-flop operating frequency of 10 megacycles guaranteed minimum. Transatron Electronic Corp., Wakefield, Mass.

Circle No. 147 on Inquiry Card

## MINIATURE RELAY

Designed for industrial applications requiring 1 to 8 Form C's where space saving and weight reduction are important, a new relay features welded cross-bar contacts rated at 3 to 5 amps and one-piece frame and core construction to provide a sensitivity of 50 milliwatts per pole. The card actuator allows a mechanical life expectancy in excess of one-million operations. Size is 1-3/16" by 1-3/16" by 3/4" and weight is 0.95 oz. for the 4-pole unit. Unit costs range from \$3.40 for two poles to \$6.60 for eight poles in quantities from 1 thru 9. Phillips-Advance Control Co., Joliet, Ill.

Circle No. 178 on Inquiry Card

## DISC-MEMORY SYSTEMS

Two self-contained disc-memory systems ready for "plug-in" operation with computerized communications or control networks were designed for use as original, on-line equipment in commercial or military computer systems. The new memory systems were developed in the course of meeting several disc-memory requirements in the digital dispatching and control systems fields. Capacity of the new memories ranges up to 27,033,660 bits for the largest configuration. Model L-414 is a two-disc memory with 512 tracks. Model L-424 has 1024 tracks on two discs mounted on a common shaft, one at each end of a double-ended motor containing precision, preloaded bearings. Each individual track has its own aero-dynamic read/write head which "floats" just above the surface on a cushion of air

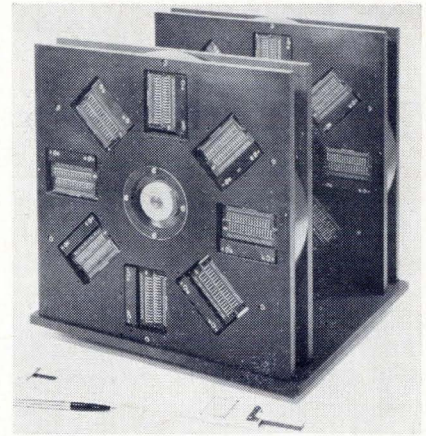

created by the rotation of the disc. The cobalt-plating, the non-wearing aerodynamic design of the heads, and the precision-balanced motor drive combine to give the units trouble-free life with minimum maintenance. Librascope Group, General Prec., Inc., Glendale, Cal.

Circle No. 160 on Inquiry Card

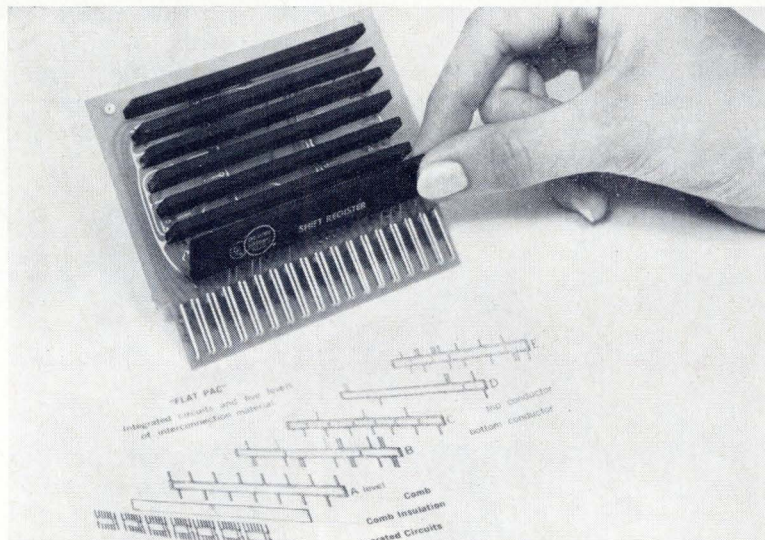

## IC INTERCONNECT SYSTEM

High density method of interconnecting flat pack integrated circuits, called MicroSystem, incorporates the advantages of quick delivery, all welded connections, high density and low cost. It is said to be easy to design with, specify, and use. From 2 to 10 or more flat pack integrated circuits can be intercon-

nected and encapsulated in one "stick." An assembly of 10 unencapsulated flat packs in only 4" long by 1/8" thick by 0.425" wide is just 0.2 cu. in. Price is about \$25 in small quantities for one MicroSystem stick using 6 or 7 flat pack integrated circuits with over 80 interconnections. Engineered Electronics Co., Santa Ana, Cal.

Circle No. 165 on Inquiry Card

### WIRELESS IC PACKAGES

A flatpack integrated circuit is said to be so sturdy it can withstand a hammer-blow. The new flatpack construction uses Kovar ribbon leads directly bonded to thin-film aluminum bonding pads on the silicon substrate. The bonding area is said to be 10 times that of the conventional bonded gold-wire construction. After the leads are bonded, the chips and lead tips are hermetically-sealed by coating them with silicon dioxide and molding them in glass. The package can be made of glass alone or with glazed metal or ceramic lids that fit over the chip and leads. After plating, the packages look like regular 14-lead flatpacks and can be tested and assembled into equipment without changing the customary facilities for testing and assembly. By elimination of gold, the packages can be stored at 400° centigrade without danger of "purple plague." The wireless flatpack construction is much less expensive than conventional flatpacks with wire leads, according to the company. ITT Semiconductors, West Palm Beach, Fla.

Circle No. 197 on Inquiry Card

### MAGNETIC REED RELAYS

Magnetically biased dry reed switching relays feature vernier adjustment for variable operation in normally-open, latching and/or normally-closed contact modes. Units consist of a unique assembly of a hermetically-sealed dry reed switch, a coil, and a movable permanent magnet. Position of the permanent magnet is adjustable by means of a fine thread adjustment screw, permitting adjustment of operating values to exact circuit requirements at the breadboard or assembly stage or in the field to compensate for environmental conditions. The new principle centers on the variable biasing of two fields for actuating reed switch contacts: one field from a coil and the other from a permanent magnet. The position of the permanent magnet varies its contribution to the magnetic flux in the working gap of the switch. Contact operation occurs in response to the net magnetic field at the air gap as determined by the sum or difference between the magnetic and electromagnetic fields. Adjustment is performed by applying the exact required operating voltage, and varying the position of the magnet. The threshold point can be set with extreme accuracy in this manner. Aero-Mec Electronics, Los Angeles, Cal.

Circle No. 194 on Inquiry Card

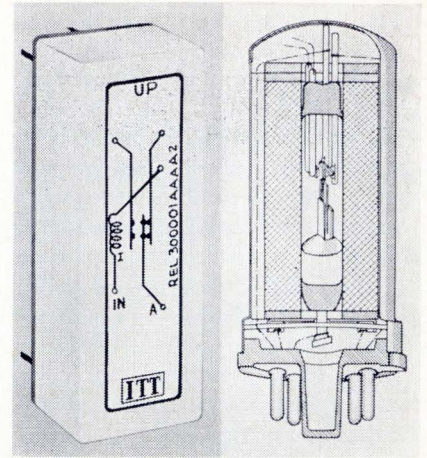

### MERCURY-WETTED RELAYS

Mercury-wetted reed relays featuring a life of 1 billion operations have a high current capacity of 2 to 5 amps, depending on the type. According to the manufacturer there is no contact bounce and no contact wear and the units have very low and constant contact resistance. They are said to be suited for computers, tabulating machines, servomechanisms, and signaling devices. ITT Export Corp., New York, N.Y.

Circle No. 173 on Inquiry Card

### VOLTAGE REGULATORS

Automatic voltage regulators for use in the process control, computer and communications fields provide closely-regulated output voltages from varying ac input voltages. Single-phase models for 115-, 230- or 460-volt, 60 cycle, operation are available in ratings from 1.15-through 60-kva. Three-phase models are available from 230- and 460-volt, 60 cycle, operation in ratings from 5- through 104-kva. The automatic units are designed to maintain a preselected output voltage level with an accuracy of  $\pm 1$  percent and feature voltage correction rates from 10.4 to 34.4 volts/second. To assure accuracy in the new units, an SCR control is combined with a Sylvan-Kettler static-sensing device to govern the voltage regulator automatically by a dead-band type voltage-sensitive control utilizing either lamp or Zener bridges. General Electric Co., Schenectady, N.Y.

Circle No. 171 on Inquiry Card

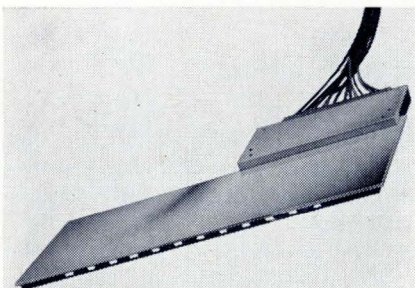

### PHOTOVOLTAIC CARD READER

Standard card reader assembly is applicable to all IBM-type punched cards. Construction provides for

positive registration of punched holes to optic sensing head. This unit is said to eliminate problems due to lint, dust, moisture, and other forms of contamination. The fiber optic bundles are placed on a 0.250" c/c spacing and transmit light to solar cells with 0.100 c/c spacing. The design of the assembly allows for the telescopic mountings of assemblies to facilitate any number of card reader positions. Solar Systems, Inc., Skokie, Ill.

Circle No. 184 on Inquiry Card

## NEW PRODUCTS

### NEW TELETYPE MACHINE

Business form preparation with the Teletype Model 35 automatic send-receive set has been simplified to eliminate time-consuming repetitive manual typing, form positioning, and programming by the operator. These improved capabilities are featured in a new machine, the Teletype Model 35 Automated Communications Set. Greatest usage of the unit is expected to be in the fast, accurate preparation of customer orders for transmission "on-line" or for entering them directly into a computer or associated business machines for processing. Key to the new set is the automatic combining of repetitive information contained in punched paper tapes with variable data entered on the keyboard by an operator. A clear page copy with carbon copies is produced simultaneously with a corresponding tape for use in data communications. Operation is at speeds of 100 words per minute (10 characters per second). Form preparation is controlled by two tape readers, which sense and interpret fully-perforated eight-level, one-inch wide paper tape. The Model 35 ACS fea-

tures a four-row, typewriter-like alphanumeric keyboard for easy operation without extensive training. In addition to the preparation of business forms, the ma-

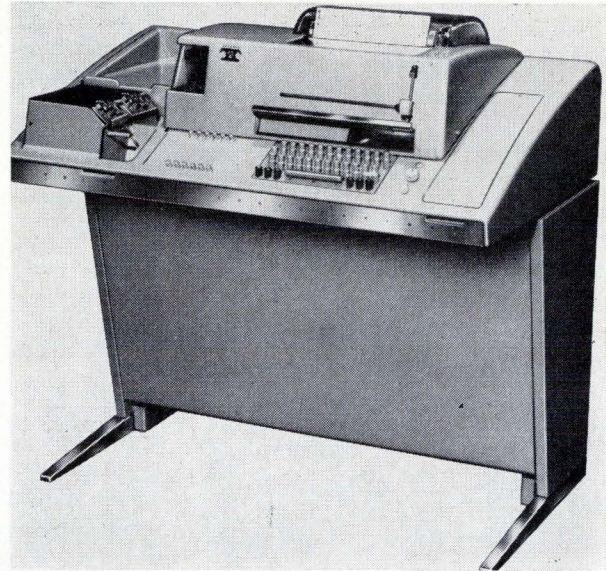

chine has application in a wide variety of communications functions, including the receiving, integrating, forwarding, and disseminating of messages and data of all types. Teletype Corp., Skokie, Ill.

Circle No. 138 on Inquiry Card

## A DESIGN REFERENCE GUIDE

### "CAUSES AND CURES OF NOISE IN DIGITAL SYSTEMS"

By J. Paul Jones, Jr.

#### A 56-PAGE POCKET-SIZE HANDBOOK

Excellent design tips and basic guideline rules for eliminating or minimizing noise in digital systems are given. Here is just a partial listing of topics:

- Electrostatic Interference in Backplane Wiring
- Worst-Case Cabling of Wires
- Inductive Noise in Systems Backplanes
- Routing of Circuit Grounds
- Use of Output Clamps • Output Filters
- RFI-Proofing • AC Power Line Noise
- Driving Diode Matrices • Power Supplies for Very High Noise Locations • Test Points

**PRICE: \$1.75 per copy**

**Bulk quantity prices available on request.**

**To order your copy, simply fill out coupon below, enclose check or money order, for \$1.75 per copy, payable to Computer Design Publishing Corp. Shipment will be made immediately upon receipt of order.**

COMPUTER DESIGN PUBLISHING CORP.  
BAKER AVE., W. CONCORD, MASS. 01781

GENTLEMEN:

Enclosed is \$..... for ..... copy(ies) of 56-page Handbook — "CAUSES AND CURES OF NOISE IN DIGITAL SYSTEMS".

SHIP HANDBOOK(S) TO:

NAME .....

COMPANY .....

ADDRESS .....

CITY ..... STATE .....

### BINARY CONVERTERS

Analog-to-digital converter produces a BCD serial output code by successive approximation methods. The device incorporates its own reference supply, all timing and programming circuits, and has sample and hold characteristics. Standard models are available for three BCD digit encoding in 1 millisecond. Input levels of 0 to 1 volt or greater can be accommodated. The unit is supplied as three completely-calibrated  $4\frac{1}{2}'' \times 5\frac{1}{8}''$  plug-in boards. Total power consumption is less than 1.5 watts from dc supplies of +12 volts and -12 volts. Single unit prices start at \$890.00. Towson Laboratories, Baltimore, Md.

Circle No. 132 on Inquiry Card

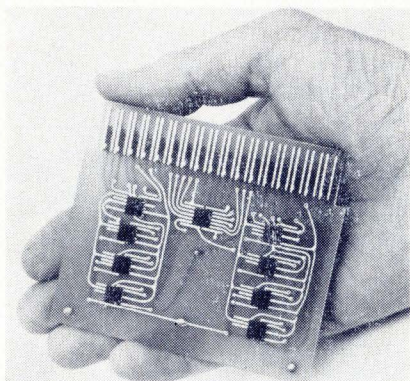

### IC LOGIC CARDS

Line of compatible integrated circuit digital logic cards are available in three types of units: basic elements (flip-flops, NAND gates, exclusive OR gates, and other elements); combinations of these elements (such as counters, shift registers, half and full adders) to provide system functions; and special cards (but still compatible) interconnected to custom needs quickly and at near "off-the-shelf" prices. Standard cards are  $3\text{-}7\frac{7}{8}''$  wide x  $3\text{-}\frac{1}{4}''$  high. Logic elements, power supplies, mounting hardware and peripheral circuits are available from stock. Engineered Electronics Co., Santa Ana, Cal.

Circle No. 149 on Inquiry Card

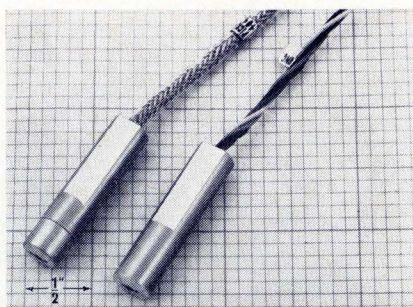

### MAGNETIC DRUM HEAD

New miniature magnetic memory read record head for use with non-contacting magnetic memory or storage drums can be used alone, or in multiples in a variety of operating mounts. Heads are individually adjustable for head-to-drum spacing. Maximum mechanical stability which is said to insure top performance efficiency over long periods of time is achieved by incorporating a metallic structure throughout the new unit. Even the supports are made of aluminum. The Model 4047D has been designed for integration into both solid-state and vacuum tube circuits and will withstand continuous application of 120 ma. dc without damage. Standard inductance is 67 microhenries for each leg, at 100 kc, with a gap of 0.001". Industrial Prods. Div., Pickering & Co., Plainview, L.I., N.Y.

Circle No. 146 on Inquiry Card

### IC MODULES

Series of plug-in modules featuring monolithic integrated circuits provides entire subassemblies such as scalars, registers, and decoders on a single circuit board. Modules include a 32-bit shift register with all outputs available and a 20-bit scalar with both input and output gating. Modules are offered individually and in custom-designed systems. Linear Alpha, Inc., Evanston, Ill.

Circle No. 158 on Inquiry Card

### IC CAPACITORS

A variety of layered construction, uncased capacitors can be mounted directly on integrated circuit substrates. Because of their dense, stacked structure these "Ceramam" capacitors are said to have a higher capacity-to-volume ratio than other ceramic capacitors. The capacitors, which may be readily fitted to any package requirement, can be supplied in any geometric configuration and are available with either axial or radial leads of tinned copper, weldable and weldable/solderable alloy materials. Hi-Q Div., Aerovox Corp., Olean, N.Y.

Circle No. 180 on Inquiry Card



### PULSE GENERATOR

A new 10-megacycle pulse generator features risetime under 3 nanoseconds, tightly-specified waveform, and a full set of independent, calibrated controls. Unit delivers pulses of more than 10 volts into 50 ohms, and prevents error producing reflections by presenting a constant 50-ohm source impedance. Four calibrated range knobs are provided, each with a vernier; independently

controlled repetition rate (10 pps to 10 mc), pulse width and trigger output delay (each 20 nanoseconds to 5 milliseconds), and amplitude. The generator may also be externally triggered. Its duty cycle capability exceeds 50% at all rates above 100 pps, so it will readily produce symmetrical square waves. Fully specified are width jitter (less than 0.2%), overshoot and ringing (less than 2%), rounding (no sooner than 95% of full pulse height), and rise and fall time (less than 3 nsec). This Model 222A pulse generator, in a rack-convertible modular enclosure, is  $5\frac{1}{2}$  inches high, and is priced at \$690. Hewlett-Packard, Palo Alto, Cal.

Circle No. 142 on Inquiry Card



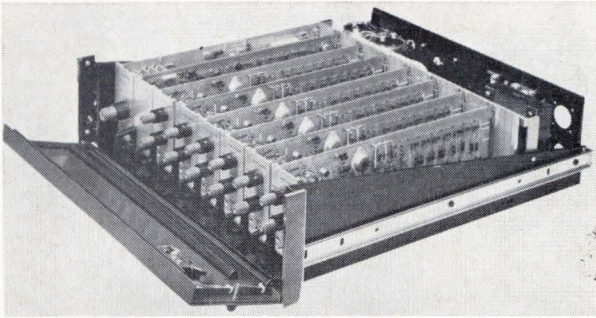

### DIGITAL CHARACTER GENERATOR

A character generator for printing Arabic numerals on oscillograph records can be used with all oscillographs without modification. The device is said to combine, in one instrument, the best features of the fastest digital printer available and an analog light beam oscillograph. Time correlation of digital and analog data can be obtained on the same oscillogram. Up to 26 columns of numbers can be printed on the record at speeds up to 1600 lines per second. The numerals can be placed at any point across the width of the oscillogram and may be varied in height and width. Printing is accomplished optically using galvanometers. The operation requires no flash tubes or moving mechanical parts. Called the DataDigit Character Generator, the instrument is benchmounted or rackmounted with the oscillograph and includes a case/power supply, a synchronizer section consisting of two plug-in units, and up to six plug-in mixer amplifiers. Each mixer amplifier will write a column of decimal numbers. Two galvanometers are required for each character. Price of DataDigit with six channels is approximately \$3000. Consolidated Electrodynamics Corp., Pasadena, Cal.

Circle No. 125 on Inquiry Card

### HIGH-SPEED COUNTERS

Military navigation-type high-speed counters include both tandem and dual, direct-drive mechanical units providing easy-to-read digital readout in degrees and minutes. They are said to be especially-suited for crowded instrument panels where concise, quick and accurate readout is essential such as in trainers, computers, tracking and guidance systems, and similar applications. The Series 1758 tandem counter uses two banks of readout wheels in a common frame for in-line reading. While a single input shaft drives both banks, only one bank is exposed at a time. The shutter transfers from one bank to the other when an "all zeros" reading appears, indicating the equator or zero meridian. Shaft rotation is maintained in one direction during the complete cycle. The Series 1759 dual counter has the two banks located one on top of the other, rather than in-line. For a given rotation direction of the drive shaft, one bank adds while the other subtracts. Veeder-Root Inc., Hartford, Conn.

Circle No. 120 on Inquiry Card

# NEW . . . VersaSTORE INTEGRATED CIRCUIT CORE MEMORY



to see what's stored  
just look at the lights!

VersaSTORE gives you a bright incandescent lamp display of address and data registers that lets you see the data stored in the memory. This is only one of many features on the new VersaSTORE Memory. Integrated circuits in the VersaSTORE allow substantial size, weight and cost reductions. Very flexible signal and power requirements allow input and output signals from 3v. to 12v. with PNP or NPN interface available as standard. The only power required is  $\pm 12$  volts. VersaSTORE memories operate at 2  $\mu$ sec. speeds, and use the servoed current drive to insure exceptional operating margins over a wide temperature range. The exclusive VersaSTORE "DATAGUARD" protects the memory content during system checkout.

The new VersaSTORE memories are built around a truly modular, flexible plug-in concept, and are available in capacities of 128 to 4096 words to 24 bits, in only 5¼ inches of standard relay rack space.

For more information on VersaSTORE memories, write to:



**DECISION CONTROL, INC.**

1590 Monrovia Avenue, Newport Beach, Calif.  
Tel. (714) 646-9371 • TWX (714) 642-1364

CIRCLE NO. 32 ON INQUIRY CARD

### A-D CONVERTER

A high-speed analog multiplexer and high resolution A-D converter have been combined into a single chassis requiring only 7" of panel height. The unit accepts from 5 to 100 analog inputs, and samples at rates up to 29,000 readings per second with 4-decimal-digit resolution. Maximum resolution is 14 binary bits or 4 BCD decimal. Any channel can be gated to read its output on a front panel display during full speed multiplexing and digitizing. Electronic Engineering Co., Santa Ana, Cal.

Circle No. 122 on Inquiry Card

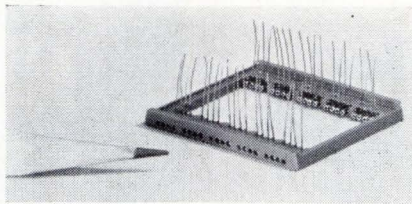

### IC BOARDS

New micromodule packaging techniques for integrated circuitry include carrier boards used as building blocks for integrated circuit assemblies. Each board is 1 1/4" square and carries and connects up to 12 integrated circuit flat-packs. The board functions as both a means for mechanical support and also as a connector. Contacts are attached to the bottom edge of each board to mate with contacts in a module base. This enables a board to be removed from a module without desoldering. ITT Cannon Electric, Los Angeles, Cal.

Circle No. 121 on Inquiry Card

### DIGITAL DECOMMUTATION SYSTEM

Designated the DD-1024, a new digital decommutation system was designed to receive complex signals from missiles and satellites, and translate them for study by computers in ground tracking stations. The principles involved in the new unit may also have other applications such as commercial airlines safety-of-flight telemetry and power company telemetry. Features of the DD-1024 include: 10-bit digital output, in parallel form, for automatic data processing by computer, which can also be used to drive a digital display; up to ninety analog readout outputs, each capable of driving oscillograph recorded galvanometers, display meters, and pen recorder amplifiers; and digital memory techniques in the analog readout channels which yield an infinite memory capability, that is, there is no slope-off with time between samples, even at the lowest operating rates. Continuing tuning rate selection permits selection of any rate within the range of 1 pps to 10,000 pps without extra plug-in rate modules. Stellarmetrics, Inc., Santa Barbara, Cal.

Circle No. 130 on Inquiry Card

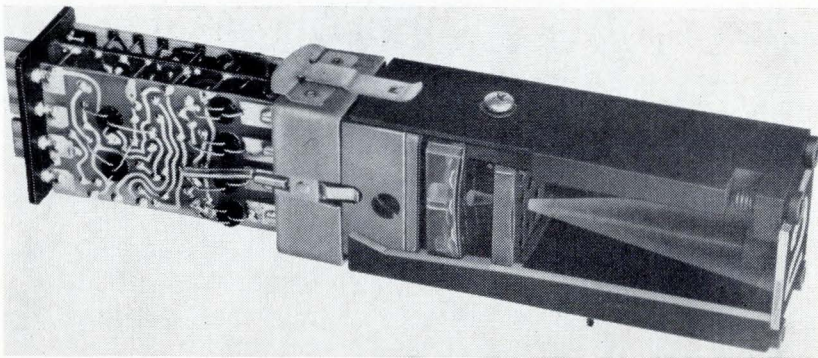

### READOUT DRIVER/DECODER

Solid-state driver/decoder module provides binary to decimal conversion for rear-projection readouts. It utilizes all silicon transistors and offers four-wire BCD input logic with an 8421 binary code which provides 10 decimal outputs. The unit also features forbidden code rejection and is available with memory as an option. The module accepts a binary-coded input, translates it into decimal, and lights the proper lamp in the readout to display the desired character. It operates on a

low current signal of 2 ma maximum at -6.0 vdc or at +6.0 vdc depending upon the option selected. Both the Series 120 and Series 220 rear-projection readouts used in conjunction with this new driver/decoder offer 12 different message displays consisting of anything that can be photographed, such as numbers, letters, words, multi-words, symbols, special characters, and colors. Prices on the new driver/decoder module start at \$85.00 in 1-9 quantities. Industrial Electronic Engineers, Inc., Van Nuys, Cal.

Circle No. 136 on Inquiry Card

### MINIATURIZED RESISTORS

New hot-molded resistor rated 1/8-watt at 70C ambient offers a theoretical packaging density approaching 730,000 units per cubic foot. The resistor, with full length leads, has an average weight of only 0.074 grams. Units are made by an exclusive hot-molding process and are fully insulated with a molded jacket. They may be used with encapsulating casting resins. Leads are adaptable to substantial weld schedule latitude, and they are solder coated to make them readily solderable, even after long periods of storage. The resistors are available with resistance values from 2.7 ohms to 100 megohms and tolerances of  $\pm 5\%$ , 10%, and 20%. Allen-Bradley Co., Milwaukee, Wisc.

Circle No. 199 on Inquiry Card

---

# 1,500,000-bit "scratch pad"?

---

Here's a Fabri-Tek memory system approaching "scratch pad" speed but with full memory capacity. It has a 1-usec cycle time and a 450-nsec access memory organization component economies of system. All silicon well-known Fabri-Tek result in exceptional reliability. The Fabri-Tek HIPAC stack is one of the reasons for the high speed and wide operational margins of this system. HIPAC stack density result in much higher switching drive currents. Delay per bit is (approx. 10 psec.). This oscillogram shows all 1's being read and restored. Scale and circuit design speeds at moderate phenomena are low gram shows all 1's is .1 usec per division. With this new Fabri-Tek Series MF 1-usec Memory System you can do anything you're doing now — but do it faster and

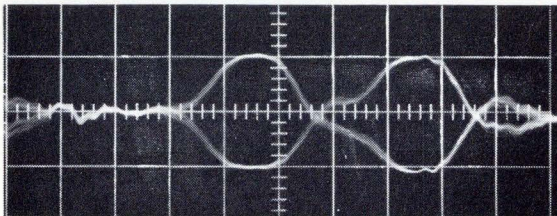
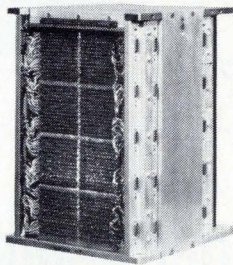
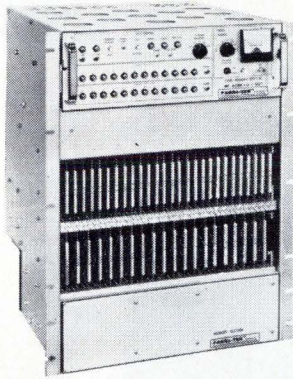

more economically! For Radar data processing — cut down the number of components and solve real-time problems with greater savings in time and equipment. Where computer time is money — get more for your dollar! For more information on the Fabri-Tek Series MF 1-usec Memory System, phone, write, or wire Robert E. Rife, Fabri-Tek Incorporated, Amery, Wisconsin. Congress 8-7155 (Area 715), TWX: 715-292-0900.

---

## FABRI-TEK®

RELIABILITY, RELIABILITY, RELIABILITY

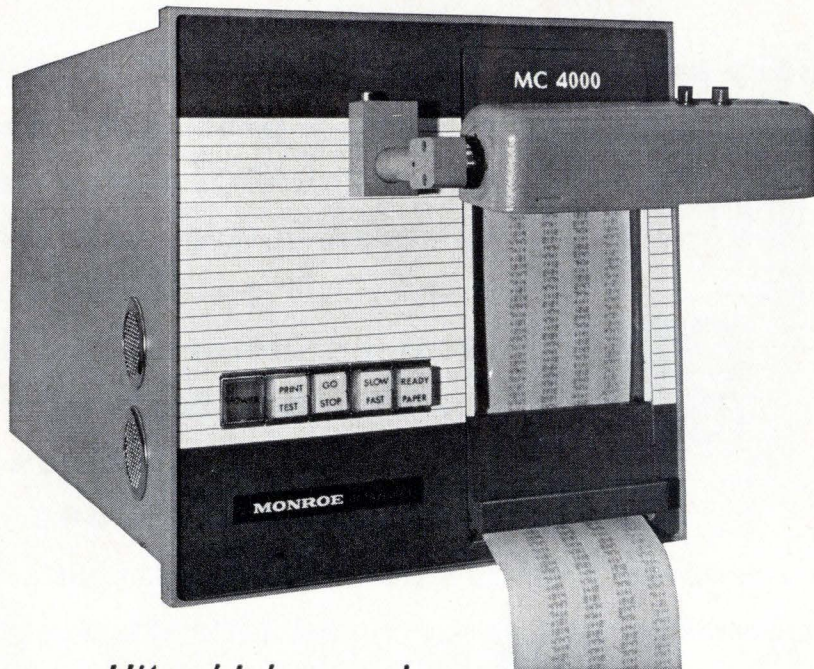

*Ultra high speed*  
*Monroe DATALOG®*  
*MC 4000 Printer delivers*  
**6000 lines per minute!**

That's 100 lines per second, synchronous or *any* speed less than 100 lines per second that your application might require. The MC 4000 is truly synchronous or asynchronous.

A non-impact printer. Completely silent. Absolute reliability.

It's available in a numeric model (15 characters in each column) or in an alphanumeric model (43 to 64 characters in each column). Both models are 32 columns wide and have the same 6000 lines per minute printing speed.

Look at these MC 4000 features: Character serial input, bit parallel. Data transfer time of 50 microseconds (no buffers required). Only two moving parts—the paper feed stepping motor and the fan. Compact: 10½" high, 10¼" wide. Rack mount available. All solid state with cathode ray tube through fiber optics.

Any 4 line code for the numeric model; any 6 line code for the alphanumeric model. Any logic level.

Price, just \$5650 for the numeric, \$5850 for the alphanumeric model.

Reliable. Silent. Ultra high speed. Synchronous or asynchronous.

And, like all Monroe DATALOG printers, the MC 4000 is covered by a full year's warranty with on site maintenance.

*For additional information, specification sheets or a demonstration, write or call Monroe DATALOG Division of Litton Industries, 343 Sansome, San Francisco. (415) 397-2813.*

**MONROE DATALOG** 

A DIVISION OF LITTON INDUSTRIES

CIRCLE NO. 34 ON INQUIRY CARD

## NEW PRODUCTS

### TELEMETRY PROCESSOR

A stored-program telemetry processor is said to be available at a cost considerably below that of conventional telemetry decommutation systems. It provides fully automatic control and setup of all required parameters and functions between receiver outputs and display devices, eliminating human error and costly setup time. Accepting a full range of inputs, the processor automatically decommutates and merges the telemetered data into a variety of standard peripheral equipment. The Model 8420 incorporates signal conditioning, decommutating, formatting and display functions into a small, standard cabinet. Arithmetic and control functions of the processor may be controlled independently, permitting both general purpose and special purpose computation. Beckman Instru., Inc., Systems Div., Fullerton, Cal.

Circle No. 151 on Inquiry Card

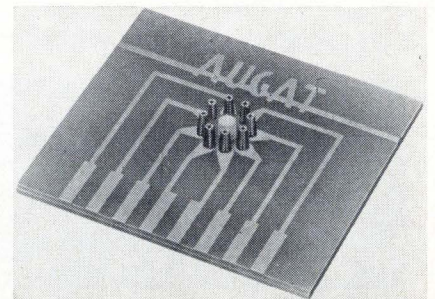

### IC TEST SOCKETS

New series of test sockets for integrated circuits contained in TO-5 cases plug into standard printed circuit board connectors. Counter-sunk beryllium copper contacts in printed circuit board facilitate lead entry and insure low contact resistance. Units are said to offer reliable and expeditious method of testing. Price range: \$1.55 to 2.55 each, depending on quantity and number of contacts. Augat Inc., Attleboro, Mass.

Circle No. 152 on Inquiry Card

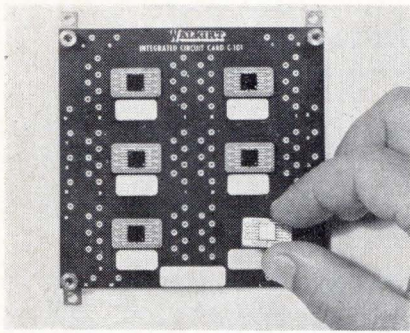

### IC BREADBOARD SYSTEM

Breadboard system allows rapid and economical assembly of integrated circuits flat-packs into final system configuration. The system consists of individual carriers of IC's and a PC mother board which allows up to six IC carriers to be plugged in, or soldered, to the mother board. Several mother boards can be conveniently attached to each other so that final array of mother boards is just like a production system, with practically no sacrifice in system size. Wiring hook-ups are made to forked terminals on opposite side of the IC's to prevent damage during assembly wiring. By using all available plug-in features, individual IC's and mother boards can be used over and over again in other systems. The circuits can easily be removed from individual carriers and/or the carriers can be removed from the board if replacement of either item is required. Walkirt, Los Angeles, Cal.

Circle No. 137 on Inquiry Card

### DATA MULTIPLEXER

A new computer entry device, designated Model 1000 Universal Data Multiplexer, is a multi-channel data collecting and recording system. The system is modular in construction, and is capable of multiplexing and recording data from ten real-time channels, expandable up to 1000 channels. Input data can be of any code and of any logic voltage level. An input adapter is provided for each channel to convert the input data to the common language of the system. Information Technology, Inc., Sunnyvale, Cal.

Circle No. 156 on Inquiry Card

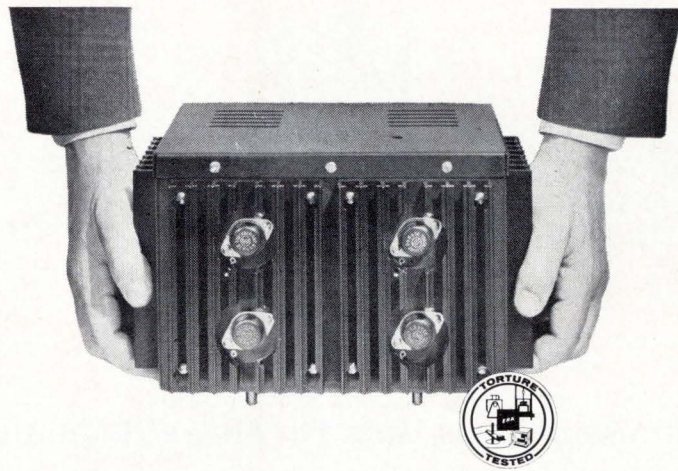

# 1/2 cu. ft. x 40 AMPS!

## Now—Up to 40 Amps (and 31 VDC) from a single ERA Transpac® all-silicon DC power module

New, compact ERA high current Silicon Transpacs provide current ratings of 15A, 25A and 40A with voltage ranges from 1 through 31 VDC in minimum space. Rated for 71°C *free air* operations, all models are fully repairable and are ideally suited for all high current, highly regulated and low ripple applications.

### Specifications

<b>Input:</b> 105-125 VAC, 50-400 cps	<b>Voltage adjustment:</b> Screw driver adjustment
<b>DC output:</b> 1 through 31 VDC	<b>Transient response:</b> Less than 50 microseconds
<b>Current:</b> 15A, 25A, 40A depending on model type	<b>Operating temperature:</b> -20°C to +71°C free air, full ratings
<b>Regulator type:</b> Solid-state, silicon transistors, silicon diodes	<b>Maximum case temperature:</b> 125°C
<b>Ripple:</b> Less than 800 microvolts RMS	<b>Temperature coefficient:</b> Less than 0.01% per °C or 3 millivolts
<b>Line regulation:</b> Better than ±0.01% or 5 mv for full input change	<b>Long-term stability:</b> Within 5 millivolts for 8 hours
<b>Load regulation:</b> Better than 0.05% or 8 millivolts for 0-100% load change	<b>Heat sinking:</b> Internal, convection cooled
<b>Output polarity:</b> Ungrounded outputs	

### REPRESENTATIVE MODEL DATA\* (45 models available for off-the-shelf delivery)

Max Current Rating	Size	Weight	Price
15 amperes	9 <sup>7</sup> / <sub>8</sub> x 11 <sup>1</sup> / <sub>4</sub> x 7 <sup>1</sup> / <sub>2</sub> inches	33 lbs.	\$430.00
25 amperes	13 x 15 x 7 <sup>1</sup> / <sub>2</sub> inches	53 lbs.	\$515.00
40 amperes	16 <sup>1</sup> / <sub>2</sub> x 16 x 7 <sup>1</sup> / <sub>2</sub> inches	67 lbs.	\$685.00

\*Choice of voltage 1 through 31 VDC, all current ratings.

Write for Catalog Supplement #143

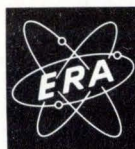

## ELECTRONIC RESEARCH ASSOCIATES, INC.

Dept. CD-10, 67 Sand Park Road, Cedar Grove, N. J. 07009 (201) CEnter-9-3000

Subsidiaries: ERA Electric Co. • Advanced Acoustics Co. • ERA Dynamics Corp. • ERA Pacific, Inc.

CIRCLE NO. 35 ON INQUIRY CARD

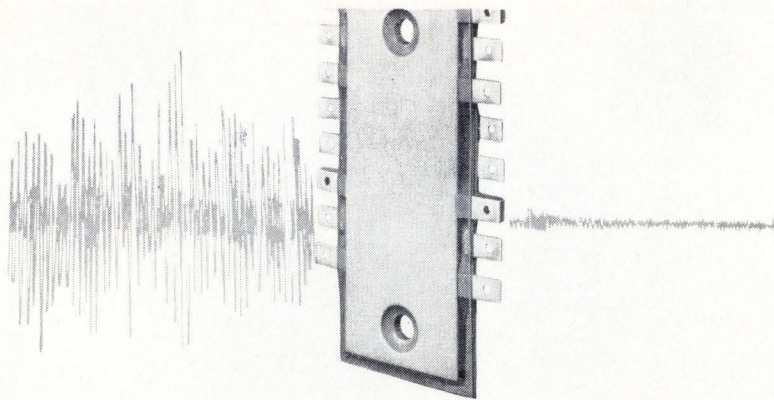

## Laminated Bus Bars For Noise Reduction

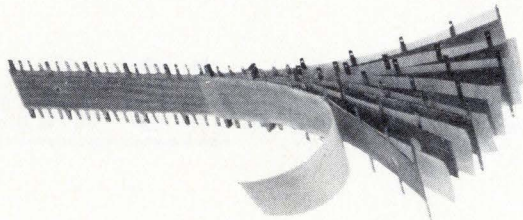

Flat bus conductors laminated with Eldre's thin, rugged insulation will reduce electrical noises which cause havoc in high speed, solid state equipment. Lower the inductance and control the capacitance of your vital power distribution lines. Ground shields are interleaved with the voltage-carrying conductors so that effective shielding can be adequately provided. The terminations of each conductor, as shown, are for soldering but other types can be incorporated into the bus design. This compact and completely molded bus can replace a bulky harness and repetitive wiring.

Increase the reliability of your circuit with a bus system and obtain efficiency.



COMPONENTS INC. • 1239 UNIVERSITY AVENUE • ROCHESTER, N. Y. 14607

CIRCLE NO. 36 ON INQUIRY CARD

Now — the most adaptable, reliable

## DATALITE<sup>®</sup> SYSTEM OF INDICATION

For computers, data processing,  
and other readout applications

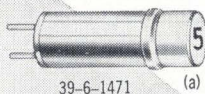

39-6-1471



7538 W/39-6-1471

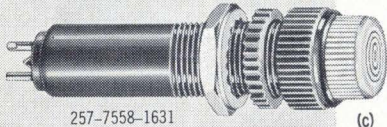

257-7558-1631

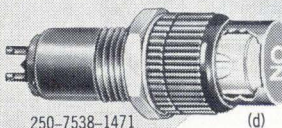

250-7538-1471

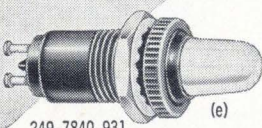

249-7840-931

Build your light indicators with a system—the DATALITE system. Here's how: Choose a "Datalamp" Cartridge (a) and combine it with a "Datalamp Holder" (b); or use a screw-on "Data Cap" with a rotatable readout lens (c, d)... For multi-indications, "Datalamp" Cartridges may be mounted on a "Data Strip" or "Data Matrix" in any required configuration.

"Datalamp" Holders accommodate DIALCO's own plug-in ultra-miniature Neon or Incandescent "Datalamp" Cartridges. Complete assembly mounts in  $\frac{3}{8}$ " clearance hole. Also available with permanent (not replaceable) Neon lamps (e). Legends may be hot-stamped on cylindrical lenses. Styles shown here are only typical components in the extensive DATALITE system of light indication.

**SAMPLES ON REQUEST—AT ONCE—NO CHARGE.**

For complete data, request current Catalog.

(Illus. approx. actual size)

Foremost Manufacturer of Indicator Lights

**DIALIGHT** CORPORATION

60 STEWART AVENUE, BROOKLYN, N.Y. 11237 212 HYACINTH 7-7600

**DIALCO<sup>®</sup>**

CIRCLE NO. 37 ON INQUIRY CARD

## NEW PRODUCTS

### TAPE SPLICER

New tape splicer can be used for punching, correcting, or building codes in edge-punched cards. The device combines in a single unit a precision tape splicer, a tape gauge to assure proper code registration of tapes being processed, and a manual tape punch for rapid correction of coding errors and punching special codes. It can be used with 5, 6, 7, and 8-channel punched tapes. The splicer section has facilities for cutting and splicing coded tapes simply, accurately, and using almost any type of splice. Data-Link Corp., Los Altos, Cal.

Circle No. 157 on Inquiry Card

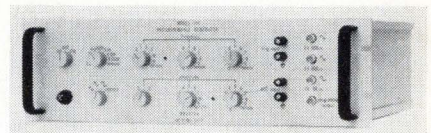

### DIGITAL FUNCTION GENERATOR

A "universal" function generator allows automatic digital programming of frequency, function, and amplitude. Model 155 has both remote and manual controls while Model 150 is remote only. Either of the units will produce virtually any combinations of sine, triangular, or square waveforms, eliminating the normal requirement of a separate generator for each stimulus in an automatic system. Frequency, function, and amplitude can be programmed by tape reader or punched cards through a rear-mounted 50-pin connector. Standard card sets are available to convert either model to the proper interface for specific codes or logic-level controls. The units also feature triggered control in which a 5vdc gate triggers the output at a predetermined frequency and level. Price of the Model 150 is \$995; the Model 155 is \$1,195. Wavetek, San Diego, Cal.

Circle No. 124 on Inquiry Card

COMPUTER DESIGN/OCTOBER 1965

## COMPUTER TAPES

An advanced line of high-reliability computer tapes was produced by an exclusive "Micro-Plate" process which provides, according to the manufacturer, tape surface. Cohesion between the oxide and binder system is also said to be significantly improved in the new tapes. Type 224 and Type 225 are tested and certified on each of seven channels throughout the length of each reel at 556 bits per linear inch and 800 bits per linear inch, respectively. Type 226, also certified at 800 bits per linear inch, is full-width tested, thus providing a tape for current use which will also meet the increasing demands of future generations of computers. Reeves Soundcraft, Danbury, Conn.

Circle No. 134 on Inquiry Card

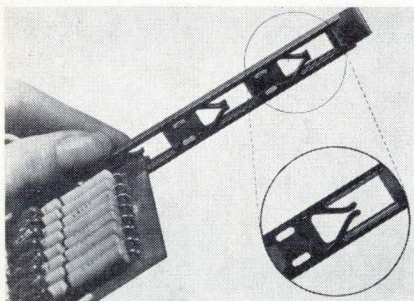

## PC CARD GUIDE

A high-strength, one-piece, precision-molded polycarbonate card guide was designed to hold printed circuit cards firmly in place under stresses of up to 150 G's. Card-gripping power is provided by means of integral cantilever springs which accommodate printed circuit boards ranging from 0.050 to 0.125 inches in thickness. Thus board warpage or variations in thickness do not affect gripping power. In addition to the positive gripping action provided by the integral cantilever springs, another significant feature of the new card guide is fast mounting. Molded-in press lugs make it possible to snap card guides into place quickly and easily without the use of rivets, bolts, or other fasteners. No tools of any kind are required. Calabro Plastics, Upper Darby, Pa.

Circle No. 141 on Inquiry Card

# MODULES DRUM MEMORIES SYSTEMS

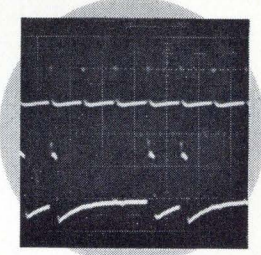
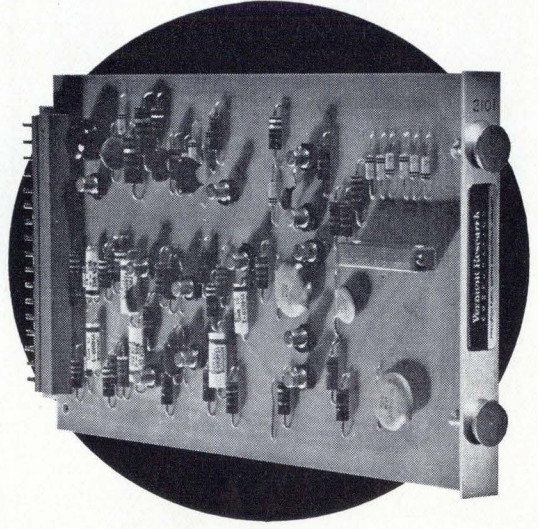
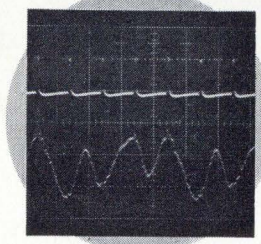

## COMPATIBILITY FLEXIBILITY RELIABILITY

*Three musts for modules.*

And VRC 2.5mc modules — including amplifiers for reading, writing and track switching—have them all. Full compatibility with integrated circuits. Plenty of flexibility to meet *your* logic requirements. Thoroughly proven reliability.

Then, too, VRC modules:

- Operate with low level signals from typical drum and disc applications;
- Convert to negative or positive logic;
- Use silicon semiconductors exclusively;
- Have advanced circuit design enabling use of standard power supplies with typical voltage regulation of  $\pm 10\%$ .

*May we tell you more?*

## FREE BROCHURE

Complete basic specifications of VRC Drum Memories and Modules, plus general design data and descriptions of special Systems.

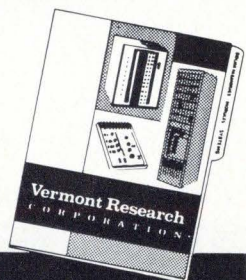

# Vermont Research CORPORATION

Box 20 a , Precision Park, North Springfield, Vermont

CIRCLE NO. 38 ON INQUIRY CARD

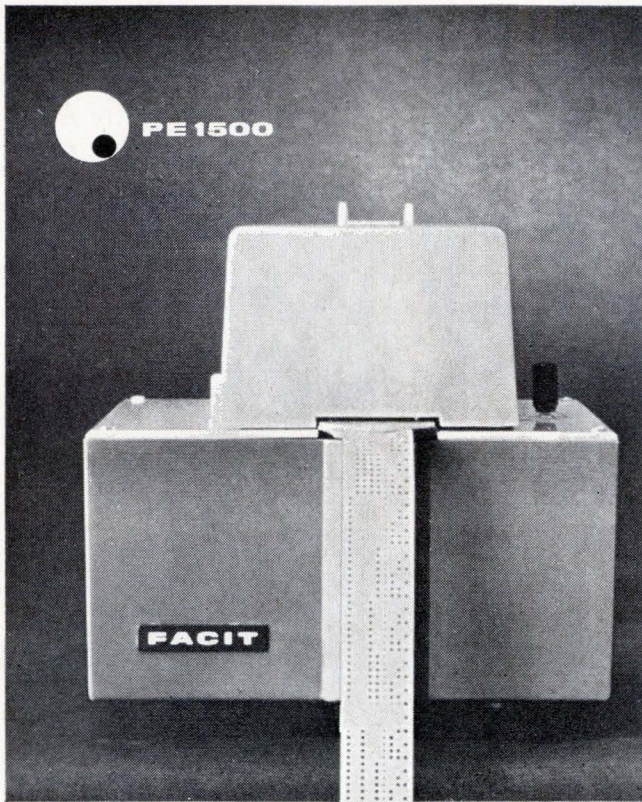

**COMPUTERS  
DATA TRANSMISSION  
DATA LOGGING**

punched  
tape output  
up to 150 characters per second  
including tapes for TTS

MANUFACTURER: Facit, Fack, Stockholm 7, Sweden - GENERAL AGENTS: Austria: P. Marchetti, Vienna  
Belgium: Thomson-Belge, Brussels - Denmark: Facit A/S, Copenhagen - Finland: Finska Kabelfabriken, Helsinki  
France: CFTH Secteur Telegestion, Gennevilliers Seine - Gt. Britain: Facit-Odhner Electronics Ltd. Rochester,  
Kent - Holland: Blikman & Sartorius NV, Amsterdam - Italy: Thomson Italiana, Milan - Japan: Kjellberg  
Kabushiki Kaisha, Tokyo - Yugoslavia: Commerce, Ljubljana - Norway: Kongsberg Våpenfabrikk, Kongsberg  
Switzerland: Venner AG, Bern - USA: Facit-Odhner Inc. New York, N. Y. - W. Germany: Facit GmbH, Düsseldorf

CIRCLE NO. 39 ON INQUIRY CARD

**NEW PRODUCTS**

**DISPLAY SYSTEM**

Table model digital information display system for rapid retrieval, editing, and composing of computer-stored information is said to eliminate card punching, batch totaling, and other intermediate steps in data processing by providing a direct interface between computer and operator. Through the use of an alphanumeric keyboard, information in a random access memory can be recalled almost instantaneously for flicker-free presentation on a 6" by 9" display area. It may then be corrected or replaced with new information and returned to the computer memory for future use. As many as 1040 characters of an easily read type face can be displayed on the TV-like screen upon operator command. The system consists of three basic units — the display console, the control unit, and an optional hard copy printer. By means of a telephone interface, the system can communicate on a time-sharing basis with a remote computer. Local buffering and high-speed display characteristics eliminate tie-ups in computer linkage. Raytheon Co., Equipment Div., Wayland, Mass.

Circle No. 123 on Inquiry Card

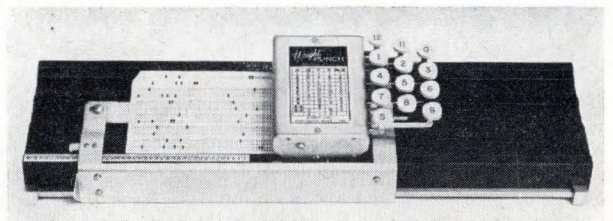

**PORTABLE CARD PUNCH**

Designed expressly for the preparation of source data where on-site recording techniques are required, a new portable card punch can be used for such applications as test data recording, warehouse inventory control, stock requisitioning, programming automatic machines, production control, and statistical compilation. The punch can also serve as an auxiliary unit for adding information to previously punched cards, such as entering special codes or instructions and recreating data from damaged cards. The standard punch is designed to handle 80-column cards; however, cost adaptors, available for any length card under 80 columns, can be installed easily by the operator without disturbing card registration. Two cards, or a two-card set with carbon paper, can be accommodated without making adjustments to the mechanism. Wright Line, Worcester, Mass.

Circle No. 127 on Inquiry Card



## THIN-FILM MEMORY SUBSTRATES

Thin-film planes are produced by placing a thin-film of either ferrite or nickel-iron metal on a plastic backing and then encapsulating the entire surface under thin plastic to protect the active magnetic domains. These substrates are said to be ideal in the production of engineering prototypes and scratch-pad memories. Company also offers a custom produced conduit matrix which is the only extra component needed. The planes are available in different unit models. Model "M" 3" x 3", with 2 1/4" x 2 1/4" actual magnetic surface area consisting of 1 mil thickness ferric slurry is priced at \$5.00. Haddonfield Res. & Mfg., Haddonfield, N.J.

Circle No. 148 on Inquiry Card

## REAL-TIME COMPUTERS

Three advanced general purpose computers are said to reach new levels of systems flexibility in real-time data processing. Designated the UNIVAC 490 Modular Real-Time Systems, the new series consists of three basic computing systems: the UNIVAC 491, 492, and 494. The 491 and 492 are stored-program computers capable of concurrently handling extremely large quantities of data in batch processing and real-time modes. The standard medium scale 491 features eight input-output channels, which can be expanded to a maximum of 14. Cycle time is 4.8 microseconds per 30-bit word. The basic memory of 16,384 words can be increased in modules to a maximum of 65,536 words. For growth processing requirements, the 492 system is a compatible, more powerful system with increased peripheral capacity, memory and real-time capability over the 491. The 492 Processor has 14 input-output channels. Both the 491 and 492 can be linked to existing UNIVAC 490 installations where computer-to-computer hookup is required. Largest and most powerful of the series is the 494, a super-speed stored program computer with a 750 nanosecond memory cycle time, or 375 nanoseconds with overlapped operation. The giant 494 processes several real-time

programs concurrently with multiple batch applications. Core memory capacity of the 494 starts at 16,384 words and is expandable in increments to a maximum of 131,072 words. Standard processor has 12 input-output channels and can be increased in optional increments in groups of four to a maximum of 24. Outstanding communications control feature found on all three systems is the "Externally Specified Index." ESI handles a substantial number of communications lines through a single computer channel, using buffers in memory. This permits other transactions to run without interruptions while communications data comes into and out of the system. Monthly rental prices range from \$8,200 for the basic UNIVAC 491 to \$14,000 for the 494. Purchase prices are \$328,000 for the 491 and to \$588,000 for the large-scale 494. Sperry Rand Corp., UNIVAC Div., New York, N.Y.

Circle No. 139 on Inquiry Card

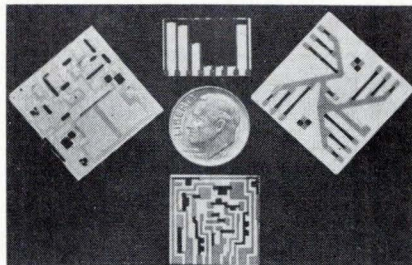

## THICK-FILM RESISTORS

Thick-film resistor networks in the 10 ohm to 1 megohm range offer low voltage coefficients and low noise factors. The networks are fired at high temperatures on rugged 1" square or smaller alumina substrates. The resistor network is then glass-passivated. Miniature components, microtransistors, silicon monolithic flat packs, toroidal inductors, miniature tantalum capacitors can be assembled to the thick-film resistor network to form a complete functional circuit package with a choice of encapsulation and lead/connector configurations. Tolerances are  $\pm 10\%$ ,  $\pm 5\%$  and  $\pm 1\%$  with power ratings of 15 watts per square inch of material. Microtek Electronics, Inc., Cambridge, Mass.

Circle No. 155 on Inquiry Card

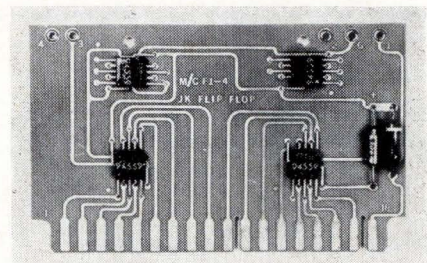

## FLIP-FLOP MODULE

An integrated circuit module contains an improved clocked flip-flop. Major improvements include preferential asynchronous entry to the direct set and reset inputs and improved output buffering to increase noise immunity and higher speeds. The redesigned clock coupling circuits allow arbitrarily presettable counters to be constructed entirely from the card without the use of additional gating structures. The card contains four independent universal flip-flops on a 2" x 3-1/4" military approved epoxy-glass card and is available off the shelf at \$74 in small quantities. Microsystems Components, Woodland Hills, Cal.

Circle No. 162 on Inquiry Card

## DIGITAL CONTROL PLOTTER

Principal function of a new digital controlled automatic drafting/plotting machine, called the Coradomat, is the conversion of digital data into an analog graphic form. The system consists of a drawing table and a control computer. Since a wide variety of accessory units are available for use with the basic system, the machine can be used for converting pairs of graphical coordinates into corresponding digital data. There are three main application areas for the equipment: mapping, microelectronics, and computing. In all three cases, the full advantages of automatic operation can only be utilized in conjunction with a digital computer. A unique feature of the machine is that the X and Y movements are controlled by a high precision lead screw which is monitored through a digitizer wherein one window represents one place on the lead screw at materials of 4/10 of 1/1000 of an inch. Faul/Coradi, Auburn, N.Y.

Circle No. 145 on Inquiry Card

## NEW PRODUCTS

### INTERCONNECTING SYSTEMS

A new form of flat cable interconnecting system was designed to solve complex connecting problems in small, irregular shaped and very thin areas. The system was used on the Phoenix missile as shown in photo. More than 550 random interconnections connect over

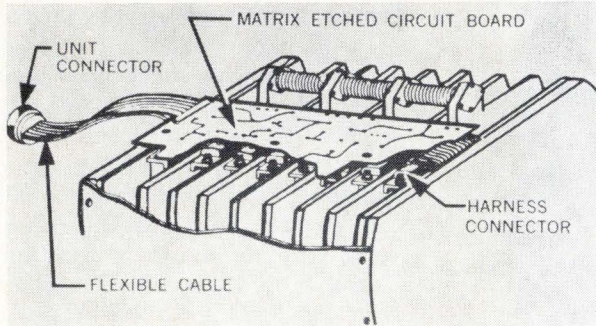
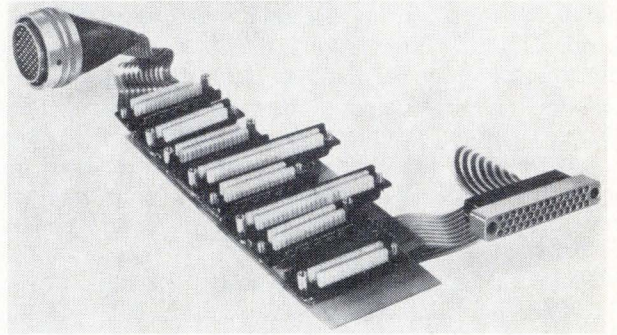

6000 separate components. Modular construction allows easy, rapid modification of circuitry — easy to plug in, or out, all or part of the system. The systems are supplied complete, to customer specifications, with all connectors attached, ready to plug in. Digital Sensors, Inc., Los Angeles, Cal.

Circle No. 129 on Inquiry Card

## TELETYPEWRITER FUNDAMENTALS HANDBOOK By Wm. D. Rexroad

**HANDY POCKET-SIZE BOOKLET IDEAL FOR:** REFERENCE BOOK

- TRAINING PROGRAMS • SALES AIDS FOR SWITCHING COMPUTER MFGRS.
- LIBRARIES • EMPLOYEE EDUCATION • CUSTOMER INDOCTRINATION

**MAJOR TOPICS:** BASIC PRINCIPLES OF TELETYPEWRITERS

HOW THEY OPERATE • Signal Generation & Reception • Baudot Code & Eight Level Codes • Teletypewriter Distortion

HOW THEY ARE USED • Simplex, Half-Duplex, Full Duplex • Neutral & Polar Circuits • FSK & RTTY

GLOSSARY OF TELETYPEWRITER TERMINOLOGY

DESCRIPTIONS & PHOTOS OF TELETYPEWRITER MACHINES

\$1.50 per copy Quantity prices available on request

COMPUTER DESIGN PUBLISHING CORP.  
BAKER AVE., W. CONCORD, MASS. 01781

GENTLEMEN:

Enclosed is \$..... for ..... copy(ies) of  
TELETYPEWRITER FUNDAMENTALS HANDBOOK.

NAME .....

COMPANY .....

ADDRESS .....

CITY .....STATE .....

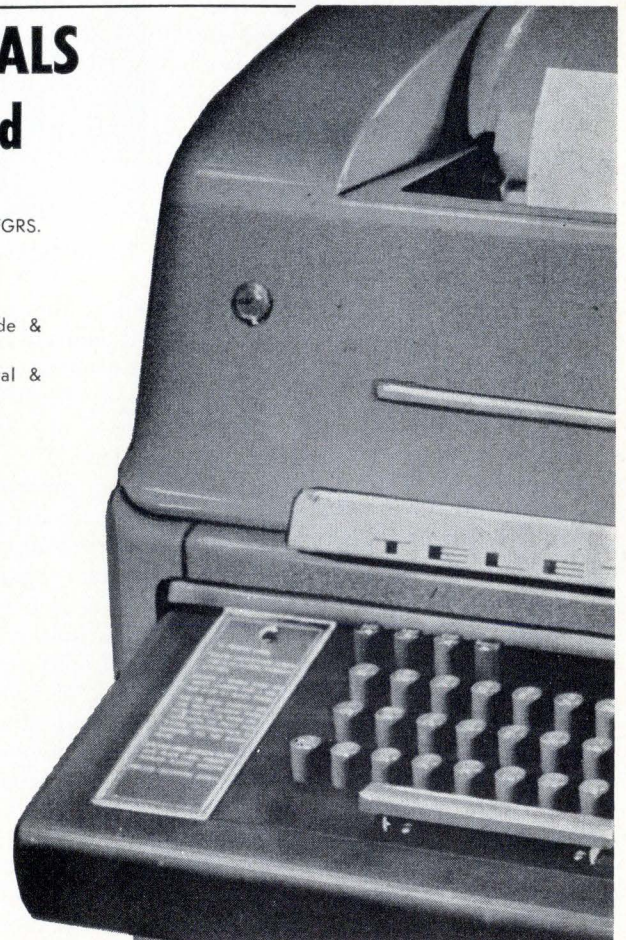

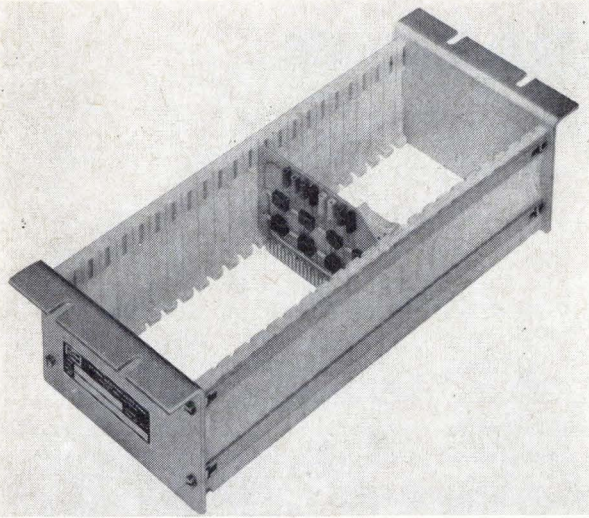

### IC MOUNTING HARDWARE

New line of packaging hardware was developed for the specific problems associated with the support of integrated circuits. The new hardware includes nylon-molded guides, spacers and ejectors and complete files, and horizontal and vertical equipment drawers for support of miniature mother boards. Included also are mountings to attach baby boards to mother boards and new units which permit multiple circuit connections without conventional connectors. Another design allows removing circuit chips for testing without cutting wires or damaging glass insulation. SCANBE Mfg. Corp., Monterey Park, Cal.

Circle No. 133 on Inquiry Card

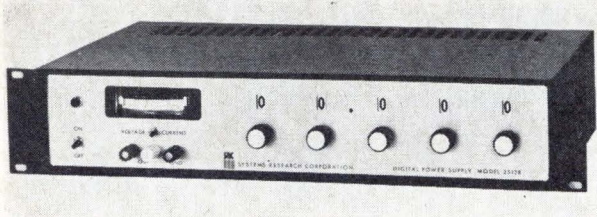

### DIGITAL DC POWER SUPPLY

New isolated 5-decade digital dc power supply is available in two operating modes: 0-100 volts with one millivolt resolution; and 0-10 volts with 100 microvolt resolution. Both units deliver up to 100 milliamperes current. With dc isolation of 10,000 megohms, ac line isolation of 0.1 pf, and 0.002% per degree C temperature stability, this supply has a repeatability accuracy of 0.005%. Applications include operation as a 0.01% working standard (with current output up to 100 ma); linearity checks on data systems; voltage-controlled oscillator applications; dynamic range, linearity and gain checks on dc amplifiers; reference source for analog computer installations; and isolated strain gauge/transducer power supply. Price is \$995. Systems Research Corp., Los Angeles, Cal.

Circle No. 131 on Inquiry Card

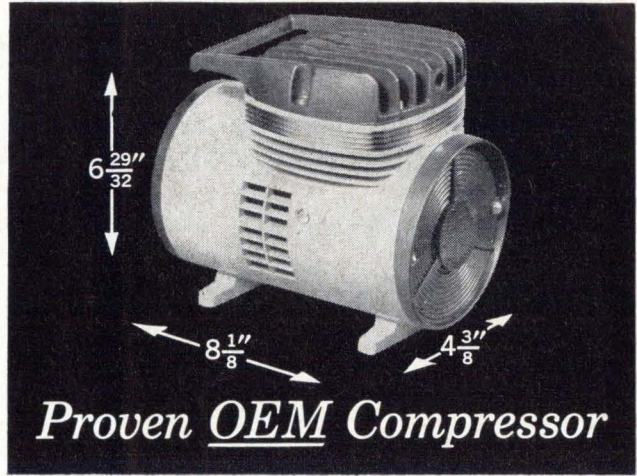

Need a compact, heavy-duty compressor or vacuum pump with a 40 p.s.i. capability in the .25 to 1.65 cfm range? Our Series 906 motor-driven diaphragm unit is a low-cost answer. Weighing only 9 pounds, it is available with a choice of 6 different curves and either a shaded pole or permanent split capacitor 115- or 230-volt, 50-60 cy. motor. The long-life, Thomas Series 906 compressor requires no lubrication . . . features rugged die-cast aluminum construction, sealed ball bearings and a 10,000-hour diaphragm.

The Series 906 and other Thomas pumps can be custom-engineered to meet your O.E.M. needs. Write or call for full particulars. Compressor Division, Thomas Industries Inc., 207 East Broadway, Louisville, Kentucky.



THOMAS INDUSTRIES

CIRCLE NO. 40 ON INQUIRY CARD



**NOW, a low-cost, self-decoding readout with uniform brightness**

**Performance Plus Economy.** Simplified optical system provides brighter, more readable display with perfect uniformity between characters.

**Self-Decoding.** Decoding is inherent in the design. No additional electronics required.

**Long Lamp Life.** Lamp is constantly lit. Lamp life is not decreased by switching on and off.

**Simplified Maintenance.** One lamp to replace—one lens system. This means less down time for expensive equipment.

**Lower Cost.** Straightforward design saves you money in purchase cost, maintenance and down time.

Width 1-9/16", Height 2 1/8", Length 5 1/2", Digit Size 1", Weight 10 oz. 6 or 12 volt lamp; Circuit 20 volt Standard. Other voltages available.

Write for literature and prices



5806 West 36th St., Minneapolis, Minnesota 55416. Phone 929-1681

CIRCLE NO. 41 ON INQUIRY CARD

# the most accurate inertial-grade encoders on the market!

**DRC** doesn't make big, clumsy encoders. Too complicated, too unreliable, too inaccurate, too large for boosters and spacecraft.

**DRC** encoders are small, rugged, simple, and dependable. They're optical shaft-angle encoders that utilize a rotating moiré pattern, low-intensity lamps, wide-aperture optics, and push-pull sensors. Large signals and error cancellation are the result (pulse-to-pulse errors of less than 1 arc-second). Problems of temperature excursion, power supply variations, lamp aging, and shaft loading are minimized.

**DRC** makes both standard and special models, in resolutions ranging from 100 to 1,048,576 counts per turn, in sizes from 1" to 3½" diameter. For all applications. Some are being used now on Saturn, Titan II, and other classified government projects.

We are willing and able to back up our "most accurate" statement. Try us.

**DYNAMICS  
RESEARCH  
CORPORATION**  
  
38 Montvale Avenue, Stoneham, Massachusetts  
Telephone 617-438-3900 • TWX 617-438-0069

CIRCLE NO. 42 ON INQUIRY CARD



## LITERATURE

### Wire-Wound Resistors

A 16-page catalog describing a complete line of precision wire-wound resistors provides detailed technical specs on high-reliability units, epoxy-cast resistors for military, commercial and industrial applications, and series-molded resistors. Technical data on printed-wiring resistors for easy mounting on standard grid printed circuit boards and ceramic resistors for commercial computers, industrial instrumentation, and laboratory experimentation is also included. Custom networks are also described. Hi-Q Division, Aero-vox Corp., Burbank, Cal.

Circle No. 236 on Inquiry Card

### Digital Printers

Two high-speed digital printers are described in detail in a new brochure. The modular units have a printing capability of 1040 or 1380 lines per minute. Booklet explains the operation of the devices and gives specifications, prices, and optional accessory data. Monroe Data/Log Div., San Francisco, Cal.

Circle No. 233 on Inquiry Card

### IC Digital Modules

A 44-page catalog details a new line of silicon monolithic integrated circuit digital logic modules. The catalog features standard dc to 5 mc packages as well as mounting hardware, power supplies, and module accessories. Technical description, specs and logic diagrams for each type are included along with loading rules and typical waveforms. Computer Control Co., Framingham, Mass.

Circle No. 235 on Inquiry Card

### The Engineer's Computer

How engineers with no computer experience can solve problems with a PDS 1020 computer after a few minutes of basic instruction is explained in a brochure. It describes the PDS 1020 as a complete, full-scale, general-purpose digital computer designed with pushbutton simplicity for immediate use by the beginner. A uniquely-designed keyboard-interpreter combination enables an engineer to enter a problem and steps for its solution directly into the computer, using familiar terms rather than machine language. For the experienced programmer, the six-page brochure also describes the full general-purpose capabilities of the 1020. These include over 40 machine commands, multiple input and output capability, a hardware index register, automatic word-length control, and capabilities for both decimal and binary arithmetic. Pacific Data Systems, Inc., Santa Ana, Cal.

Circle No. 201 on Inquiry Card

### Incremental Magnetic Recorders

Short-form catalog describes various models of incremental digital magnetic tape recorders. All models incorporate a "flux-check" technique that provides instant verification of data. Each character is read immediately after recording to verify that it appears on the tape in the intended form. Output of a bit-by-bit check signals any errors which might occur owing to bad tape, failure of the tape advance mechanism, or any other cause. Data on the tape is actually read in time to effect corrective action before the succeeding character. Kennedy Co., Pasadena, Cal.

Circle No. 220 on Inquiry Card

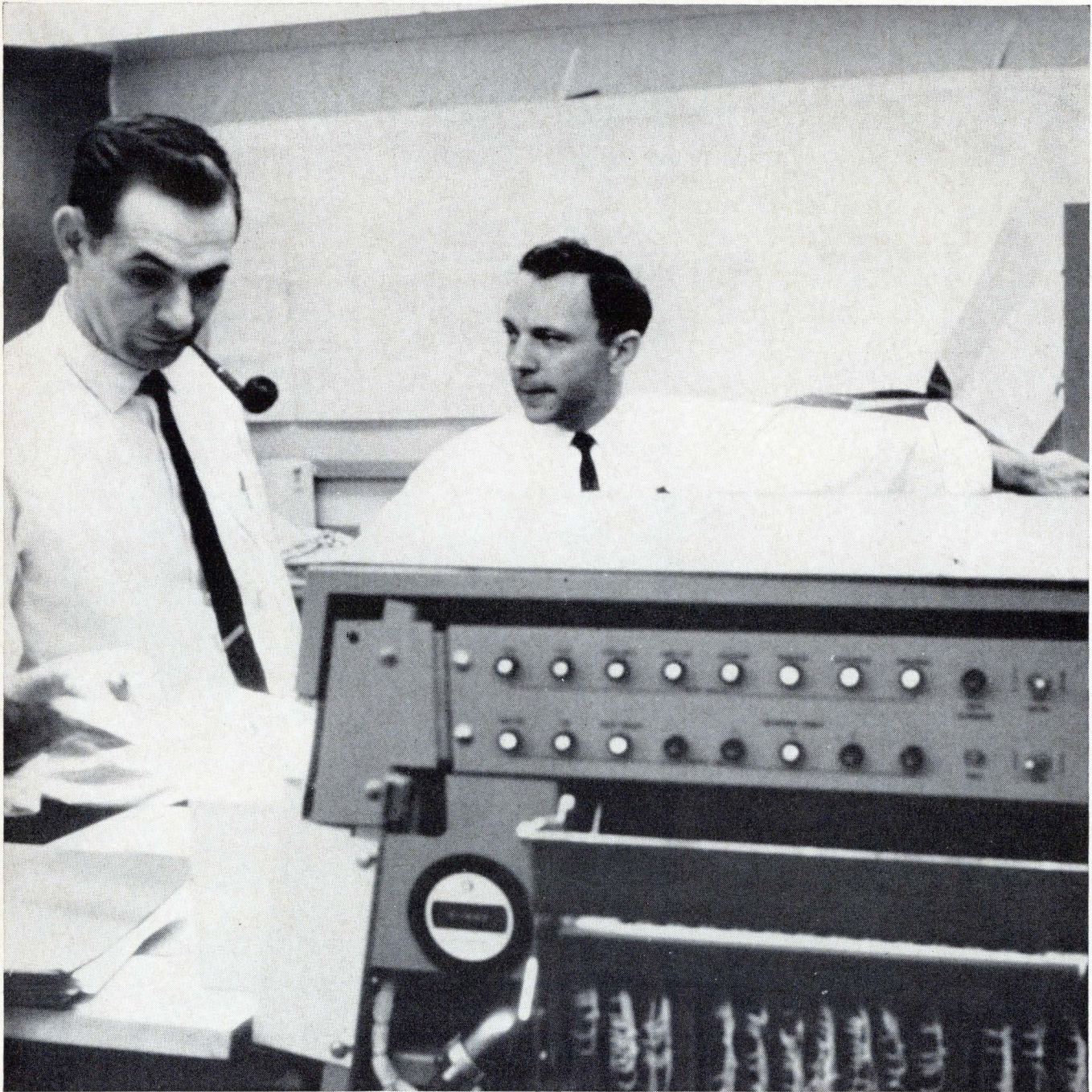

## Sometimes we have to watch our language.

**(Especially when engineers visit our labs.)**

There tends to be a lot of computer language bouncing around Xerox these days. Some people might jump to the conclusion that we're going into the computer business. That's not exactly true.

There's a simple answer to why all the talk about information storage and retrieval, communications theory, bandwidth compression, transmission, digital analysis, coding, and the rest. It is all related to Graphic Communications. Can you see where we're going? There's ample room for some canny computer-based systems people to join us.

Write us about what you've done in the field and we'll try to pinpoint your most promising opportunities at Xerox today. Address your letter or resume in strictest confidence to Mr. Robert Conboy, Xerox Corporation, Dept. CD-10, P. O. Box 1540, Rochester, New York 14603.

**XEROX**  
An Equal Opportunity Employer

---

## LITERATURE

---

### Indicator Lights

Catalog presents a complete line of one-terminal indicator lights for use on grounded circuits. It contains lamp data, illustrations, drawings, and catalog number charts to facilitate selection of the required indicator lights. Dialight Corp., Brooklyn, N.Y.

Circle No. 237 on Inquiry Card

### Digital Modules

A 16-page catalog supplement provides general descriptions, detailed specs, and logic and application diagrams on 12 recently-developed germanium digital modules. The circuits include 8- and 10-bit digital-to-analog converters, a universal flip-flop, and a module which can be used as a half-adder, a subtractor, a comparator, or a parity generator. Raytheon Computer, Santa Ana, Cal.

Circle No. 221 on Inquiry Card

### Transistor Selector Guide

Selection guide permits the user easily to choose the high-frequency amplifier or switching device which most closely fits his exact performance requirements. The guide categorizes devices for high-speed saturated logic, small-signal amplifiers, current-mode switches, core drivers, pulse amplifiers, micro-power devices, choppers, field-effect transistor applications, and high-voltage and general-purpose amplifiers. The new guide covers over 100 different high-frequency silicon annular transistor types for both amplifier and switching service. Motorola Semiconductor Products Inc., Phoenix, Ariz.

Circle No. 203 on Inquiry Card

### Switching Transistors

High current silicon planar epitaxial NPN transistors were primarily designed for use as high current core drivers and are contained in the solid TO-5 package. The use of these high current core driver transistors is said to provide the possible elimination of sense amplifiers. Data sheets give full specs. Bendix Semiconductor Div., Holmdel, N.J.

Circle No. 231 on Inquiry Card

### Multiplex Systems

An 8-page catalog describes time division multiplex systems for remote control, alarm and status monitoring, and telemetering. It includes an explanation of multiplex theory and provides sufficient detail for the reader to design and order a complete system from the modular components described. Two supporting booklets of 4-pages each are offered, describing available equipment enclosures and control display panels. Moore Assoc., Inc., San Carlos, Cal.

Circle No. 212 on Inquiry Card

### Cable Testing

A 15-page application note, "Cable Testing With Time Domain Reflectometry", is the result of nearly two years' experience with TDR technique in coaxial cable manufacture, installation, and maintenance. The publication is accompanied by a TDR slide rule which rapidly makes many of the specialized calculations for obtaining dielectric constant, propagation velocity, characteristic impedance, and distance between discontinuities. The literature includes chapters on the theory of time domain reflectometry, cable characteristics, and testing techniques. New means of minimizing the effect of unwanted signals are described, and methods of testing longer lines. Hewlett-Packard, Palo Alto, Cal.

Circle No. 204 on Inquiry Card

### DTL Circuits

Data sheets give specs for a line of DTL integrated circuits. High noise immunity and low power are said to be the features of these circuits. Stewart-Warner Microcircuits, Inc., Sunnyvale, Cal.

Circle No. 232 on Inquiry Card

### EDP Accessories

Catalog listing a full line of accessories and supplies for EDP systems covers new improved hand field encoders; punched tape, magnetic tape, and microfilm splicers; splicing patches for standard feed and advanced feed hole tapes; an aperture card reader; reels and storage canisters for paper tapes; filing supplies for data tapes and cards; EDP equipment maintenance supplies; and a new expanded line of permanent bond and easy to remove pressure-sensitive labels for all EDP needs. Robins Data Devices, Inc., Flushing, N.Y.

Circle No. 205 on Inquiry Card

### DTL Integrated Circuits

A four-page quick reference guide presents schematic diagrams and complete model designations of 25 new DTL integrated circuits for commercial computer applications. The DTL line includes NAND gates, flip-flops, pulse binary counters, line drivers, level-detecting Schmitt triggers, and diode arrays. NAND circuits are available with one, two, three, four, and six gates having various combinations of multiple inputs, nodes, and with or without collector resistors. In addition to schematic diagrams, the booklet includes electrical characteristics for both special and standard gate configurations. Accompanying the booklet is an official price list that gives delivery information and prices for all the circuits in quantities up to 499 units. Westinghouse Molecular Electronics Div., Elkridge, Md.

Circle No. 202 on Inquiry Card

# This is the way Amperex says 'nix' to costly, complex readout from BCD

Nothing in the world says it better than the new Amperex DP101 Binary Coded Decimal-to-Biquinary conversion matrix in combination with the incomparable Amperex BiQui numerical indicator tube.

For, with the DP101 you require about 50% of the components otherwise required for BCD-to-decimal conversion. What's more, we've completely eliminated 30% of the transistors customarily found in the driver circuit for a readout tube.

As to the Amperex BiQui tube. In addition to its other conspicuous virtues, it gives

you built-in error detection that's second to none. (Any circuit failure will be visible instantly, because two numerals within the tube will simultaneously ignite.)

In other words, you get far simpler circuitry, far greater reliability, far easier maintenance, with a far smaller spare parts inventory—all, at far and away, the lowest initial cost for a conversion matrix/driver circuit/readout tube combination in the entire industry.

The DP101 meets MIL-E-16400 and MIL-STD-242 Specifications. The DP101

card (including matrix and BiQui driver) comes ready to use and needs only a standard connector and socket. A second card, designed and priced specifically for commercial applications, will be available in the near future.

For detailed information, write: Amperex Electronic Corporation, Components Division, Hicksville, Long Island, New York 11802.

**Amperex**<sup>®</sup>

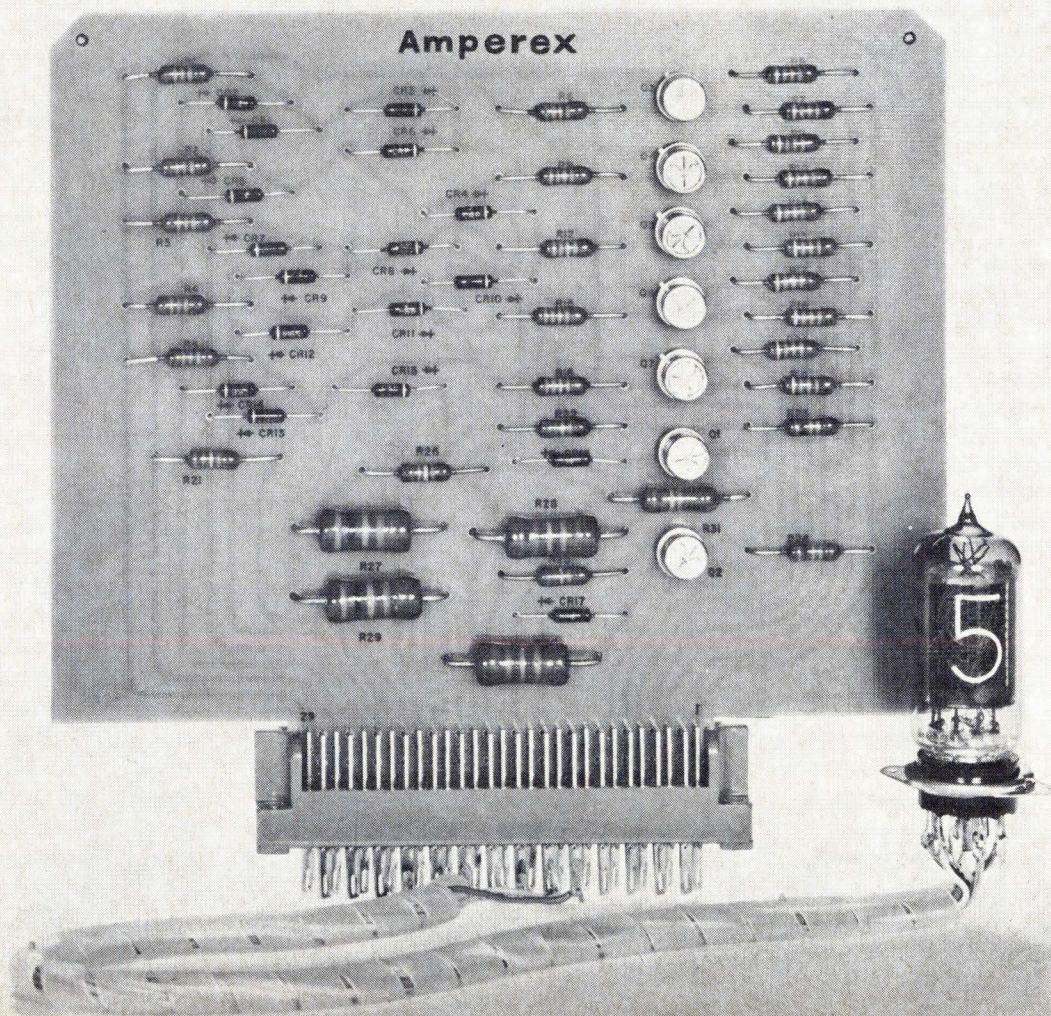

## LITERATURE

### Core Memory Planes

Three new bulletins describe core memory planes. Bulletin MP70 lists advantages of new pluggable, molded plane for coincident-current memory applications, using either 20 mil cores on a 128 x 128 matrix or 50 mil cores on a 64 x 64 matrix. The bulletin tells how instant stacking is provided by simply plugging planes one on top of another, making expansion of bit length a simple operation. A close-up view details the gold-plated male and female contacts, and a drawing shows frame dimensions and a typical winding. Bulletin MP60 describes a standard molded plane for coincident-current memory applications and bulletin MP51 details standard printed circuit planes for coincident-current and linear-select memory applications. A handy reference table allows the designer to select dimensions, array, number of senses or inhibits, core spacing, and core size for six planes using 30 and 50 mil cores. Indiana General Corp., Electronics Division/Memory Prods. Keasbey, N.J.

Circle No. 228 on Inquiry Card

### Scanner Modules

Described in a bulletin are building-block modules for the automation of precision measurement. Units accommodate from 5 to 1000 input channels. Each system consists of a Model 700 Scanner-Control module, and from 1 to 20 Model 750 Scanner Switch modules. Also available is a self-contained switch-and-control module that has a capacity of from 5 to 30 channels. Data acquisition systems involving up to 1000 channels of low-level analog input may be scanned at rates up to 30 channels per second. Output of a system may be any standard digital recording device. Dana Laboratories, Inc., Irvine, Cal.

Circle No. 223 on Inquiry Card

### Display System

Brochure describes a real-time electronic access and display system, called READ. It is a versatile alphanumeric and graphic cathode ray tube display which provides instant access to computer-stored information. Central controller of the system contains a character generator, a vector generator, and a format controller. Consoles may be provided with a typewriter keyboard, a cursor, and a light pen. Information Systems Operation, Philco Corp., Willow Grove, Pa.

Circle No. 215 on Inquiry Card

### IC Interconnection System

A microminiature interconnection system is described in a 4-page bulletin. The system is said to provide substantially increased contact density and reliability in the interconnection of etched circuit board and glass or ceramic substrates. Shown are three different locking variations which are currently available and a detailed description of the concept and its application in a Naval Research Laboratory Control System. Cinch Manufacturing Co., Chicago, Ill.

Circle No. 209 on Inquiry Card

### Data Communications Set

A 10-page brochure describes a data set which weighs only 20 pounds and is 3½ inches high and transmits at fixed rates of 2400 and 1200 bits per second over a standard 3 kc voice channel derived on cable, open wire or microwave radio. Employing integrated circuitry, the set utilizes duobinary coding, a technique which doubles the data-handling capability of standard 3 kc voice circuits and also enables automatic error detection plus a very low error rate at speeds of 2400 bps. The publication includes performance figures, photographs and block diagrams. Lenkurt Electric Co., Inc., San Carlos, Cal.

Circle No. 216 on Inquiry Card

### Random Access Drum

A 4-page brochure describes how a random access drum offers independent, simultaneous multiple access to an entire information store of over 170 million bits. The brochure explains how the new system is a departure from conventional mass memories built today, in that it utilizes one, two, three, or four groups of independently positionable write/read heads consisting of up to 43 heads per group, to serve all of its 2752 separate information tracks. The write/read heads are arranged so that the corresponding heads in each group can gain access to the same data stored in any one of the assigned tracks at the same time. Bryant Computer Products, Walled Lake, Mich.

Circle No. 227 on Inquiry Card

### Miniature Indicator

Bulletin describes an internal-flag, magnetic-latching indicator that requires only pulse power for operation. The flag is positively held in position and will reverse only when a reverse-polarity pulse is applied to the same coil, or a similar polarity pulse is applied to the reset coil. The bulletin contains details on all features, electrical specifications, mechanical specifications, environmental specifications, dimensioned drawings, and wiring diagrams. Minelco, Holbrook, Mass.

Circle No. 210 on Inquiry Card

### Paper Tape Punch

A 4-page technical bulletin describes a tape punch package that combines in a single compact panel all the equipment necessary for punching tape. Any 5 to 8 level code may be accommodated at rates from 0 to 35 characters per second. Photographs, descriptions, specifications, and a simple interface block diagram showing external connections included. Invac Corp., Waltham, Mass.

Circle No. 200 on Inquiry Card



### Digital Memory Plotter

A new concept of permanent recording especially designed for use with multi-channel analyzers, averaging computers, and digital oscilloscopes is described in a bulletin. Plotting speed is 1200 points per minute; accuracy is 0.15%. The literature provides full technical description, specifications, and prices. Houston Omnigraphic Corp., Bellaire, Texas.

Circle No. 217 on Inquiry Card

### Fan Assemblies

Two-page bulletin describes new line of quiet, long-life cooling fan assemblies available for computer and electronic equipment applications. Rated 500 cfm, the suction or blower type fan assemblies are designed for all angle mounting and feature a 4-inch diameter shaded-pole motor with integral stator core insulation and a hydro-dynamic lubrication system. Included in the bulletin are performance curves and outline drawings. General Electric Co., Specialty Motor Dept., Fort Wayne, Ind.

Circle No. 219 on Inquiry Card

### Air Compressors

A new line of air compressors is described in detail in a newly-published 4-page brochure. Complete performance data, dimensions, motor types, and specifications on the various units are given along with typical applications. Featured in the line are six models offering pressures up to 40 psi with air flows ranging from 0.25 to 1.65 cfm. The integral compressors are of the diaphragm type and deliver 100 percent contaminant free air. Some possible areas of use for the new compressors include computers, office machines, graphic arts equipment, instrument air, and other OEM equipment. Compressor Div., Thomas Ind., Inc., Louisville, Ky.

Circle No. 234 on Inquiry Card



*In a bind for thin, flat, odd-shaped precision parts?*

*use the  
theory of  
probability  
to solve your problems*

This is where experience counts! Chances are, Photoforming by Hamilton will get you quickly from the drawing board stage to prototype production of thin, flat, odd-shaped precision parts. No dies . . . no burrs . . . no bent edges . . . no stresses . . . no delays when parts are produced by the Hamilton process called Photoforming. Another plus, Photoformed parts can be heat-treated, plated, or formed according to your specifications. Write for the facts—you'll get useful data on Hamilton's Photoforming and other facilities.

INDUSTRIAL AND MILITARY PRODUCTS DIVISION

 **HAMILTON**

WATCH COMPANY

LANCASTER, PA.

CIRCLE NO. 44 ON INQUIRY CARD

REMEMBER **RESE**  
FOR **MAGNETIC CORE MEMORIES**

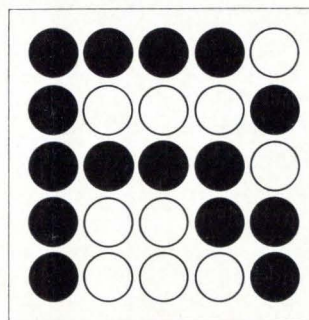

 **RESE ENGINEERING INC.**

A and Courtland Streets, Philadelphia, Pa. 19120 (215) GL5-9000

CIRCLE NO. 45 ON INQUIRY CARD

## LITERATURE

### Digital Logic Modules

An 18-page bulletin describes a complete family of 100 kilocycle digital logic modules which fulfill the requirement for low speed logic systems which will operate over an ambient temperature range of -55C to +70C. Typical flip-flop prices are under \$4 each in 1,000 quantity. Electronic Modules Corp., Timonium, Md.

Circle No. 230 on Inquiry Card

### Reference Diodes

Data sheet describes 400-milliwatt, temperature-compensated silicon Zener devices in hermetically-sealed DO-7 glass packages. Units measure 0.300" in length with a diameter of 0.096" ±0.010. Voltage range at 25C, ambient is 5.9 to 6.5 volts. Voltage temperature coefficient ( $\pm\%/^{\circ}\text{C}$ ) ranges from 0.01 to 0.001. Computer Diode Corp., Fair Lawn, N.J.

Circle No. 218 on Inquiry Card

### Micrologic Modules

Typical applications of a series of micrologic modules are described in a comprehensive 40-page booklet. Presented are specification tables and diagrams showing circuit configurations, logic symbols, and signal connections for typical NOR, flip-flop, buffer, inverter, half-adder, expander, and counter modules. Circuit loading, grounding, and power distribution rules are explained. Included also is a section describing standard logic trays, files, and packaging accessories which have been designed around the modules for simplified packaging. Systems Engineering Labs, Inc., Fort Lauderdale, Fla.

Circle No. 208 on Inquiry Card

## ADVERTISERS' INDEX

ADVANCED SCIENTIFIC INSTRUMENTS	17
AMP, INC.	19
AMPEREX ELECTRONIC CORP.	77
BENSON-LEHNER CORP.	55
BRYANT COMPUTER PRODUCTS Div. of Ex-Cell-O Corp.	43
C&K COMPONENTS, INC.	27
CEDAR ENGINEERING	73
COMPUTER CONTROL CO.	Cover II
CONTEMPORARY ELECTRONICS	6, 35
DECISION CONTROL, INC.	63
DIALIGHT CORP.	68
DIGI-DATA CORP.	28
DYNAMICS RESEARCH CORP.	74
ELDRE COMPONENTS, INC.	68
ELECTRONIC ENGINEERING CO.	21
ELECTRONIC MODULES CORP.	49
ELECTRONIC RESEARCH ASSOCIATES	67
ENGINEERED ELECTRONICS CO.	20
FABRI-TEK, INC.	65
FACIT	70
FAIRCHILD SEMICONDUCTOR	Cover IV
GENERAL PRECISION, INC. Librascope Group	51
HH CONTROLS, INC.	10
HAMILTON WATCH CO.	79
HAYDON SWITCH & INSTRUMENT, INC.	14
HONEYWELL EDP	Cover III
HUGHES AIRCRAFT CO. Aerospace Div.	16
IMC MAGNETICS CORP.	36
INSTRULAB INC.	38
INVAC CORP.	18
LITTON INDUSTRIES Encoder Div.	39
Monroe Data/Log Div.	66
MAGNE-HEAD Div. of General Instrument Corp.	29
MELPAR, INC.	30
NAVIGATION COMPUTER CORP.	37
RAYTHEON COMPUTER	1
RESE ENGINEERING CO.	79
RHEEM ELECTRONICS Div. of Ex-Cell-O Corp.	47
ROYAL TYPEWRITER CO. Industrial Prods. Div.	2
TALLY CORP.	57
TELETYPE CORP.	11, 13, 15
TEXAS INSTRUMENTS, INC. Semiconductor-Components Div.	4, 5
THOMAS INDUSTRIES, INC. Sprayit Div.	73
VERMONT RESEARCH CORP.	69
WINCHESTER ELECTRONICS Div. of Litton Industries, Inc.	23
WOLF RESEARCH & DEVELOPMENT CORP.	31
XEROX CORP.	75



## **THE BEST JOCKEYS RIDE THE BEST HORSES**

... and the best engineers tend toward the best engineering companies.

You can spot the best engineering companies by their low personnel turnover (ours is one-half of the national average), their technical management depth (we have nearly 80 years' experience), their ability to grow steadily (our floor space has doubled in the last year), and their record of engineering accomplishments (this is just a one page advertisement, so we'll only refer you to our most recent pacesetter, the H-200 Series).

As for the best engineers, they almost intuitively recognize each other's ability, and want to work together.

### **How about you?**

Positions exist in nearly all major areas of advanced computer technology, with emphasis on the following:

**MICROELECTRONIC PACKAGING ENGINEERS**

**LOGIC DESIGN ENGINEERS**

**SYSTEMS ENGINEERS**

**SYSTEMS EVALUATION ENGINEERS**

**DESIGN AUTOMATION PROGRAMMERS**

**SEMICONDUCTOR COMPONENT ENGINEERS**

**ELECTROMECHANICAL ENGINEERS**

**MEMORY DEVELOPMENT ENGINEERS**

**MASS STORAGE MEMORY ENGINEERS**

*Interested Engineers are invited to forward their resumes to Mr. Edwin Barr, Employment Supervisor, 200 Smith Street, Dept. CD-01, Waltham, Massachusetts 02154*

# **Honeywell**

**ELECTRONIC DATA PROCESSING**

*Opportunities exist in other Honeywell Divisions. Send resumes to F. E. Laing, Honeywell, Minneapolis, Minnesota 55408. An equal Opportunity employer.*

**does Fairchild  
make memories?**

**no.**

**but we do make  
memories better.**

Everything you need past the stack you can get from Fairchild: Core drivers, diode matrices, linear integrated amplifiers, integrated digital logic modules, etc.

FAIRCHILD SEMICONDUCTOR / A DIVISION OF FAIRCHILD CAMERA AND INSTRUMENT CORPORATION ■ 313 FAIRCHILD DRIVE, MOUNTAIN VIEW, CALIFORNIA, (415) 962-5011 ■ TWX: 910-379-6435

**CIRCLE NO 46 ON INQUIRY CARD**