

Proceedings

of the

Western Computer Conference

Held by the
Joint IRE-AIEE-ACM Computer Conference Committee
Los Angeles, California, February 4-6, 1953

Sponsors:

The Institute of Radio Engineers Professional Group
on Electronic Computers
The American Institute of Electrical Engineers Committee
on Computing Devices
The Association for Computing Machinery

Published by
The Institute of Radio Engineers, Inc.
1 East 79 Street, New York 21, N. Y.
June, 1953

CONFERENCE COMMITTEE

Chairman

G. D. McCANN.....California Institute of Technology

Secretary

SIDNEY S. GREEN.....International Telemeter Corporation

Treasurer

WILLIAM GUNNING.....Rand Corporation

R. G. CANNING
University of California
at Los Angeles

PAUL MORTON
University of California
at Berkeley

JOHN M. SALZER
Hughes Aircraft Company

LOCAL ARRANGEMENTS COMMITTEE

Chairmen--Technical Sessions

ELDRED C. NELSON.....Hughes Aircraft Company
CHARLES STRANG.....Douglas Aircraft Company
H. D. HUSKEY.....Wayne University
C. H. WILTS.....California Institute of Technology

Chairman--Registration Committee

WILLIAM L. MARTIN.....Telecomputing Corporation

Chairman--Publicity Committee

J. R. BRADBURN.....Consolidated Engineering Corporation

Chairman--Hotel Arrangements Committee

PAUL DENNIS.....William Miller Corporation

Chairman--Exhibits Committee

J. F. KALBACH.....William Miller Corporation

Chairman--Publication Committee

JOHN M. SALZER.....Hughes Aircraft Company

LIST OF EXHIBITORS

AMERICAN MACHINE & FOUNDRY CO.....Boston, Massachusetts
ANALYZER CORPORATION.....Los Angeles, California
BECKMAN INSTRUMENTS, INC.
 Berkeley Scientific Division.....Richmond, California
BENSON LEHNER CORPORATION.....West Los Angeles, California
BURROUGHS ADDING MACHINE COMPANY...Philadelphia, Pennsylvania
CLARY MULTIPLIER CORPORATION.....San Gabriel, California
COLEMAN ENGINEERING CORPORATION.....Los Angeles, California
COMPUTER RESEARCH CORPORATION.....Hawthorne, California
CORBETT SCIENCE LABORATORIES.....Los Angeles, California
DIGITAL CONTROL SYSTEMS, INC.....La Jolla, California
ELECTRONIC ASSOCIATES, INC.....Long Branch, New Jersey
ENGINEERING RESEARCH ASSOCIATES
 Division of Remington Rand, Inc.....St. Paul, Minnesota
FRIDEN CALCULATING MACHINE CO., INC.
 Friden Calculating Machine Agency..San Leandro, California
GIANNINI & COMPANY, INC.....Pasadena, California
GOODYEAR AIRCRAFT CORPORATION.....Akron, Ohio
INET, INCORPORATED.....Los Angeles, California
NALLEY, LEONARD L.....Compton, California
NATIONAL BUREAU OF STANDARDS.....Corona, California
NORTH AMERICAN AVIATION, INC.....Downey, California
PCA, INCORPORATED.....Hollywood, California
RUTHERFORD ELECTRONICS.....Culver City, California
TELECOMPUTING, INC.....Burbank, California

PROCEEDINGS of the WESTERN COMPUTER CONFERENCE

Table of Contents

KEYNOTE AND LUNCHEON ADDRESSES

The Impact of Computer Development on the Training and Utilization of Engineers.	Dr. Simon Ramo	4
Factors Influencing the Effective Use of Computers.	Dr. R. D. Huntton	5
Scientific Manpower Problems.	Dr. L. A. DuBridge	6
New Equations for Management.	Dr. J. E. Hobson	9

SESSION III

Panel Discussion - An Evaluation of Analog and Digital Computers		19
--	--	----

SESSION I

Commercial Applications -- The Implication of Census Experience	J. L. McPherson	49
Payroll Accounting with Elecom 120 Computer.	R. F. Shaw	54
Automatic Data Processing in Larger Manufacturing Plants	M. E. Salvesson and R. G. Canning	65
Requirements of the Bureau of Old-Age and Survivors Insurance for Electronic Data Processing Equipment	E. E. Stickell	74
The Processing of Information-Containing Documents	G. W. Brown and L. N. Ridenour	80

SESSION II

Airplane Landing Gear Performance Solutions with an Electronic Analog Computer	D. W. Drake and H. W. Foster	86
The Equivalent Circuits of Shells Used in Airframe Construction.	R. H. MacNeal	98
Analog-Digital Techniques in Autopilot Design.	W. T. Hunter and R. L. Johnson	119
Applications of Computers to Aircraft Dynamic Problems.	B. Hall, R. Ruthrauff and D. Dill	128

SESSION IV

The Snapping Dipoles of Ferroelectrics as a Memory Element for Digital Computers.	C. F. Pulvari	140
Magnetic Reproducer and Printer.	J. C. Sims, Jr.	160
An Improved Cathode Ray Tube Storage System.	R. Thorensen	167
Nonlinear Resistors in Logical Switching Circuits.	F. A. Schwertz and R. T. Steinback	174

SESSION V

New Laboratory for Three-Dimensional Guided Missile Simulation.	Louis Bauer	187
A New Concept in Analog Computers	Lee Cahn	196
A Magnetically Coupled Low-Cost High-Speed Shaft Position Digitizer	A. J. Winter	203
The Solution of Partial Differential Equations by Difference Methods Using the Electronic Differential Analyzer.	R. M. Howe and V. S. Haneman	208
The Nordsieck Computer	Arnold Nordsieck	227

THE IMPACT OF COMPUTER DEVELOPMENT ON THE
TRAINING AND UTILIZATION OF ENGINEERS

Dr. Simon Ramo
Vice President Operations
Hughes Aircraft Company

(Abstract)

Computer development, in the broad sense of automatic intelligence devices for military, business, and industrial applications may some day be the greatest single user of engineers and scientists. Even today, with this field in its infancy, the shortage of properly trained scientists and engineers is the bottleneck.

This talk points out the technical difficulty of the new field and the need for training engineers and scientists in new specialties in order to progress rapidly and efficiently in the development.

Ultimately, the universities must turn out a new kind of doctor whose studies include the physical sciences, with emphasis on electronics, a study of the human brain, nature's example of a thinking machine, methods and procedures in business and industry, and government and labor rules and regulations.

Industry must particularly avoid large programs until and unless capable technical experts can be assigned to the problem. The field is too difficult to be advanced by the average scientist and engineer.

The automatic intelligence field properly developed will pay off several times over in the manpower that it uses. For each top technical man assigned for a period of computer development today, the services of scores of people can be spared during an equivalent later period. From the standpoint of the nation's security, as well as to insure the most rapid technical advances, it is justifiable to assign a substantial part of the technical effort of this nation's scientific body to computer development. This is a way to increase the nation's brainpower.

FACTORS INFLUENCING THE EFFECTIVE USE
OF COMPUTERS

Dr. R. D. Huntoon
Chief, Corona Laboratories
National Bureau of Standards
Corona, California

(Notes on talk)

The second keynote address for the Western Computer Conference was given by Dr. R. D. Huntoon, Director of the Corona, California, Laboratories of the National Bureau of Standards (a center of activity for work in guided missiles.)

Dr. Huntoon coined the word "psycho-numerosis" to describe the problem of matching computing machines to the needs of research workers and of industry. In his light-hearted but basically serious talk, he suggested to the audience of 600 scientists that Darwin's theories be applied to the evolution of "electronic brains" as well as to living ones -- computing machines, in order to survive and prosper, must adapt to their "environment."

Dr. Huntoon cautioned the group to beware of concentrating on new machines to the neglect of proper training of people to use them, suggesting that much more work is needed in ways of preparing mathematical problems for machine solution.

Dr. Huntoon ended his address by stating that he would not draw any conclusions but would only predict that in the computer art "we ain't seen nothing yet."

SCIENTIFIC MANPOWER PROBLEMS

Dr. Lee A. DuBridge
President
California Institute of Technology

(Summary)

There has been a great deal of discussion during recent years of the problems arising from the shortage of scientists and engineers. This is a serious problem but unfortunately it is also a complex one. Hence there is confusion, both as to the facts and as to the remedies. It is desirable, therefore, to be clear about what factors are affecting the demand for scientists and engineers; what factors are influencing the supply; which of these various factors are long- and which are short-term in nature and finally which remedies should be considered for the short-term or the long-term problem.

The demand for scientists and engineers is affected by the following factors:

1. A long-term rise in the percentage of scientists and engineers in the population required by an advancing industrial society. Over the long term this demand is growing and is growing in an ever-increasing rate.
2. Because of the complex nature of many of the institutions and agencies which operate in a complex industrial society (large universities, large industries and large government agencies, including military agencies) scientists and engineers are being called more and more into positions of direction and management of such institutions or agencies.
3. Because of the general nature of the current world situation there appears to be, over a substantial period of years in the future, a necessity for a high level of research and development directed toward military problems.
4. Finally, the unusually large spurt in military activity since 1950 has resulted in a large and to some extent temporary bulge in the demand for scientific and technical personnel.

The following are some of the factors which affect the supply of new scientists and engineers:

1. There has been a long-term, steady increase in the numbers of young men and women going in to science and engineering. This rate of growth in recent years has been, however, less than the rate of growth of the demand.
2. During the last 30 years there has been a reduction in emphasis in high schools on mathematics and the physical sciences which has held down the growth in numbers of students prepared to enter these fields in college.
3. The veteran program following World War II resulted in a very large but very temporary increase in number of students in the engineering field, an increase which disappeared sharply in 1950-51.
4. The number of students now entering college is at a temporary low point because of the low birth rate of the 1930s. These numbers will slowly increase over the next ten years.
5. The requirements of military service have withdrawn substantial numbers of young men from the field during or following their period of education.

The measures which may be taken to remedy this situation, among others, are the following:

A. Measures which will take immediate effect:

1. Make sure that each scientist or engineer in education, industry and the military is being used to the maximum effectiveness consistent with his training and ability.
2. Provide the maximum in subprofessional assistance and in research, development or engineering facilities to each scientist or engineer to increase his effectiveness.
3. Adjust salary scales, particularly for the older scientists and engineers, to prevent their being attracted into nontechnical positions.

B. For the medium term (2 to 4 years)

1. Give subprofessional training at high school or junior college levels to more young men

and women to serve as draftsmen, technicians, etc. to relieve scientists and engineers of routine labors.

2. Stop the drafting or calling up as reserve officers those with scientific and engineering training.
3. Examine the use of scientists and engineers in the military services and adopt methods for using them more effectively.

C. For the long term:

1. Attract more able young men and women at the high-school level into the scientific and engineering field. This can be done by
 - (a) better counseling at the high-school level,
 - (b) providing further information on the opportunities in engineering to high-school students,
 - (c) increasing salary scales to make careers in science and engineering more attractive.
2. Educate the public to recognize the contributions of science and engineering to modern society, to the welfare of people, as well as to their security, and thus increase the prestige of the scientist and engineer and improve the public's understanding of the value of his efforts.

NEW EQUATIONS FOR MANAGEMENT

Dr. J. E. Hobson
Director
Stanford Research Institute

Research produces needed facts. Men planning the course of today's industry need facts. They need dimensional facts from the laboratory and pilot plant; and they need facts on the human element in industry--the customer, the worker, and the executive.

A keen instinctive perception, an extensive background of personal experiences, and techniques acquired through trial and error guided the early leaders of industrial venture. In some instances these motivating factors still work adequately and effectively. But as the processes and operations of industry become increasingly complex and the requirements of management increasingly exact, such personalized decisions find greater difficulty in meeting the tests of competition.

The pencil must be sharpened, the blueprints for planning must be more exact in detail, and the platforms of management must be made more secure. Individual experiences and intuition are as important as ever--necessary but not always sufficient.

The words "new equations" when used with "management" suggest that there may be some new elements of equality or exactness in the function of management--or at least some new conditions, new factors, problems, or approaches in management's sphere of action. Certainly, the idea of change is implicit.

One of the definitions of the word management is "the skillful use of means to accomplish a purpose." "Skillful" and "means" indicate that the role of management groups in industry is to use in a scientific manner all available resources, methods, techniques, and facts to accomplish some purpose--usually that of company growth and development.

A concept of "equation" is "a correction or evaluation due to any varying source of error." In an industry setting, this implies that management must skillfully correct, evaluate, and appraise the factors and conditions at hand if it is to reduce errors to a minimum--errors or changes that arise from varying sources. If management is to correct and evaluate skillfully, adequate facts must be available on all of the major problem areas with which industrial management is confronted.

Presumably, this equating process has been the function of management since the days of the entrepreneur and the domestic system. However, the phrase "new equations" introduces the thought that there has been, or

soon will be, a change in the tools or means at hand--in the problems management must face--in the facts or methods available or needed--in the techniques through which it evaluates or corrects--in the relative preciseness of needed facts--or in the skill with which management can isolate and reduce the probability of error in its decisions.

If we scan the role of management as it has developed over the years, we see that important new conditions, new factors, new problems, and, in reality, new equations do appear from time to time in management. This review shows that new factors in the management equation are now emerging and that others will arise in the future.

In the days before the Industrial Revolution under the domestic system in Europe, the task of management was a rather simple one. An organizer or entrepreneur distributed raw materials to workers in their homes and collected the finished products. He owned the materials, paid or bartered for the work done, and took the risk of selling or trading the products in a local market. Foreign commerce was in the hands of a few merchants and mercantile groups. Transactions were of the simplest sort. There were no complications in organization procedure, little need for policies, little need for exactness, and little need for orderly management processes. There were, in reality, no significant factors in the management equation. A merchant or entrepreneur could operate his business successfully with only those facts he collected personally. This situation remained practically constant for about six centuries. The small changes in technology had practically no effect on the affairs of man. From the days of Homer down to the middle of the 18th century, only three small improvements were made in the method of making cloth. The rate of change in industrial affairs, as well as in technology, throughout this period was insignificant.

Suddenly, however, at least two new and important factors in the management equation came into being. One of these was capital accumulated over the years but for the most part lying idle in the hands of individuals. The other was a series of startling inventions which completely changed the existing methods of industry. The first came in 1763 when Hargreaves developed the spinning jenny. The steam engine appeared in 1782, the cotton gin in 1794, the process of making malleable iron castings in 1821, the Bessemer converter in 1855, and so on. Machinery was substituted for hand tools in production. The factory system replaced the domestic system. Large industrial organizations emerged. Although the change was more evolutionary than revolutionary, we have, since the days of Arnold Toynbee, known the period from around 1760 to about 1890 as the Industrial Revolution.

It was during this period that capital and technology were first brought together. Available capital made possible the formation of business and industrial organizations to exploit the potentials of an ever-increasing number of new inventions. It is significant, however, that prior to 1900 the major factor in the management equation had to

do with capital. Management was aware of the influence of technology, but the underlying philosophy within industry generally was to follow science, to promote the results achieved by the lone inventor, to capitalize on accidental or unexpected inventions, and certainly not to stimulate the discovery of new products, processes, and industries through organized research. Management was more concerned with the development of financial empires, with extending the boundaries of our geographical frontiers, and with company growth through various forms of financial transactions.

Throughout most of this period of industrial development, the mechanical factors of industry occupied the spotlight to the detriment (in many respects) of the human factor. The implications of this situation have indeed been far-reaching. The economic views of Marx and Engel and the early socialists have been attributed by some to the declining position of labor as one of the factors of production, and to the fact that the human element in the management equation failed to gain equal consideration to the machine in the workings and management of industry. Most of the great captains of industry during the 19th century achieved their prominence as eminent financiers, shrewd capitalists, or astute organizers. It is an historical fact that many of the great industrial decisions and managerial achievements during the latter half of the previous century were firmly rooted in capital transactions, and certainly not in the field of industrial relations, marketing, or even technology, except secondarily.

Late in the 19th century a relatively dormant factor in the management equation began to rise in importance. Management found its attention being turned quite forcibly to the human element--labor. The famous Pullman strike was a portent of the changing times. The American Federation of Labor was formed in 1886. The organization of labor increased during the following years as mass production industries came into being. However, it was not until the mid-1930's that the labor movement gained momentum with passage of the National Industrial Recovery Act and the National Labor Relations Act. The collective bargaining idea and the strength of organized labor were accelerated after World War II to the end that labor now has a major effect on the decisions of management. In fact, most industrialists today view the problems arising in the industrial relations fields as being among the more important and perhaps the more difficult with which they deal. Certainly, there is no question about industrial relations becoming one of the major problems areas of modern industry.

Almost simultaneously with the rise of labor as a human factor in the management equation, a transformation occurred in the role played by technology and research. Until about the end of the 19th century, invention remained for the most part an unorganized effort by individuals. Edison was one exception. Before most industrialists had given much thought to systematic efforts toward invention, Edison was keeping 75 men busy con-

ducting experiments and designing and building new electrical apparatus so that he could make the use of electricity practical. Edison was perhaps the originator of the idea that new discoveries could be the result of organized institutional research and experimentation, and that through this approach technology could be a powerful tool in the hands of industry. He believed that "genius is about 2% inspiration and 98% perspiration." It has been said that Edison in his drive to develop a storage battery conducted over ten thousand experiments. This approach--organized creative work toward a definite goal--signalled the entrance of an entirely new element in the management equation.

Industry in general did not at first appreciate the significance of this new set of conditions. For about twenty years, the concept of organized industrial research directed towards definite goals developed slowly. It started with establishment of an applied research laboratory by the General Electric Company in 1900. Fifteen years later there were only about 100 industrial research laboratories in the United States. However, by the end of the next fifteen-year period, i.e., by 1930, there were over 1,600 laboratories. Industry was then spending well over 150 million dollars per year in the search for new products and processes and other forms of applied research. In addition, the government was supporting research at the rate of at least 25 million dollars per year. By 1940, the national budget for research and development had increased to over 800 million dollars per year. Today, industry spends more than a billion dollars each year on research, and there are over 3,300 research laboratories in industry employing more than 165,000 people. The nation, industrial and government, is spending about \$3,000,000,000 annually on research this year.

The rise of industrial research during the past thirty years as a factor in the management equation was brought about, or at least was accelerated, by a number of well planned actions outside of industry itself. During the decade of the twenties, the National Research Council, through its Division of Engineering, conducted an organized promotional program designed to show industry why it should support applied research in its own interest. We are all familiar with the Council's Blue Book of industrial research laboratories which was started early in its program. Furthermore, the Department of Commerce, under Mr. Hoover's Secretaryship, began a long-term effort to encourage American industry to engage in and support applied research. One other major development should be mentioned. The first independent non-profit organization set up to provide research services to industry, the Mellon Research Foundation, came into being in 1915. It was followed by Battelle, Armour, Franklin, and Midwest, formed since World War II. The point has been reached where research and development now ranks along with the traditional fields of production, marketing, personnel, and finance as the major functional parts of a corporation--especially those in the technologically based industries. Industry in general no longer questions the need for organized research. Its big problem is to determine which of many promising research projects should be undertaken, and how to finance those projects--a problem of selecting

among alternatives--not one of deciding against the inevitable. This suggests that the facts management must evaluate in each case are not alone the facts of science, but rather a blending of both economic and technical facts.

While the labor and research factors in the management equation were assuming increasing importance during the first half of this century, the rate of change in the production factor was also accelerated. This change was most noticeable in the growth of mass production concepts and techniques. It was hastened by the work of such men as Frederick Taylor, the Gilbreths, and Gantt, who developed the concept of "scientific management," designed to provide management with facts it needed on complex production operations. The public marvelled at the idea of mass production and lower costs as Henry Ford began to turn out automobiles in a matter of hours instead of weeks. The use of automatic machinery resulted in tremendous increases in productivity per man. Special purpose production tools of all sorts gradually replaced general purpose equipment on the country's production lines. In reality, the economic concept for which America is best known throughout the world came into being--the idea of mass production, lower unit profits, lower prices, mass consumption, higher wages, and generally speaking, higher net profits. The trend still continues--and in fact may be entering a new stage with the wider use of automatic factory techniques, electronic instrumentation of many types, the use of nuclear energy for peacetime purposes, and various new production techniques. Advancing technology in many scientific fields has made production a highly technical endeavor. Indeed, many of today's production plants appear at first glance more like giant laboratories than mass producing units. Still another important transformation in the management equation began to develop during the past half century. This development is, in fact, still moving ahead with great force, and there are many who have called it a "revolution" to emphasize the significance and the rapidity of the changes that are coming. This factor in the management equation is the concept of marketing, or, as it is sometimes called, "complete distribution." As our nation's factories increased the flow of both producer and consumer goods, it became apparent that management's thinking on marketing had to be changed from one of "order taking" to one of aggressive selling to the mass market. Some of the great names in business over the last few decades are to be found there because of aggressiveness in the distribution field--men like F. W. Woolworth, the Hartfords of A & P, J. C. Penney, Patterson of National Cash Register, Rowe and Mills who developed the vending machine, Shields with his automats, Thomas J. Watson of IBM, and many others. The roles of advertising, public relations, and community relations all found their way quite naturally in the ever-increasing pressure for greater and more efficient distribution of industry's products. This marketing revolution brought with it a new need for an organized approach to fact-finding--economic and market research. The idea developed slowly--first in the eastern part of our country, then in the West. As industry has become more and more complex from a technological standpoint, the research functions in economics and in the physical sciences and engineering have inevitably been brought closer together. The resulting approach is now known in some quarters as "techno-economics."

Superimposed on all of these industrial developments over the last few decades in production, research, marketing, and human relations is another significant factor in the management equation--government. To a considerable extent our nation followed somewhat of a laissez-faire policy toward the business community until about the end of the Industrial Revolution. Shortly before the end of the last century, the Interstate Commerce Act and the Sherman Antitrust Act came into being and almost immediately had a major impact upon the deliberations of industrial management. Dissolution of the Standard Oil Trust, the Supreme Court's Rule of Reason, the Steel Decision, the Aluminum Company Case, price controls, wage stabilization, and the complex tax laws, to give only a few examples, bring to mind the disturbing conflict between government and business which must be encompassed by today's management. The legal questions mount as time goes on--presenting management with an ever-increasing mass of problems. Intermingled with these legal problems, brought on in large part by government, as a matter of economic policy, are those arising directly from questions of national security--defense production, amortization of facilities, allocation of materials, and restriction of output for civilian markets.

As these developments have occurred, management has been presented at each turn with new and extended equations through which it corrects and evaluates in order to produce those decisions upon which industrial progress is based. At the same time, a fundamental change has occurred in management itself. This change was first called to our attention about twenty-five years ago. As the size, complexity, and scope of industrial operations increased, there developed gradually a wholesale separation between management and ownership in much the same sense that labor and management divided at the beginning of the Industrial Revolution. Earlier in this century there were many large closed corporations presided over by men who not only held complete ownership, but who also in many cases had founded the original operation. With the ever-increasing demands for capital brought on by new technical developments, and with the rise of the investment banker, wide stock ownership began to replace private corporate holdings. The result was that management, instead of being the sole owner, became the servant of the corporate body; i.e., managers became professional administrators. Gone are the days when one man, such as the late Henry Ford, will personally hold the ownership over a vast industrial empire. We even hear now of the possibility that Ford Motor Company stock may before long be traded on the nation's stock exchanges. Perhaps, this separation of management and ownership has not presented a new factor for the management equation, but it certainly has brought about fundamental changes in the setting in which facts must be evaluated by management.

It would be difficult to attempt even a brief listing of all factors in the management equation. This would mean a recital of all the problem areas with which management is concerned. Even if such a listing were possible, it might be out-of-date when completed. Management in many ways is more concerned with the problems of tomorrow than it is with the problems of today. It must foresee the foreseeable, meet the un-

foreseeable with alternatives, lead not follow--and, in the final analysis, must steer the enterprise to further growth and development whatever the future may hold. The task is not an easy one. Industrial life in our country grows more intricate with each passing day. The intermingling of technology, economics, human motivations and incentives, and other factors in the management equation compound management's problem of evaluation, correction, and appraisal. It is more difficult to reduce or remove errors in decisions. The need for precision in the facts with which management deals is greater than ever before, and there is every reason to expect that this need will increase in the future.

Some of the new problems confronting management are intimately associated with science and engineering, but, as always, the decisions are founded on economics with adequate consideration for the human element. In manufacturing, we are experiencing a move to an advanced stage of mass production--the automatic factory. New types of instrumentation and devices of all sorts are being created to produce more complex products in greater quantities at lower cost. Electronic units with memory components are being adapted to the operation and control of machines both singly and in groups. Automatic process control is the order of the day. At every turn, management is seeking ways and means to reduce the human element in the production of goods and at the same time to perform production functions never before possible.

In research and development, the emphasis is on new and vastly superior products, on product diversification, on planning ahead to insure industry's future ten, twenty, or twenty-five years hence. The drive for technical supremacy within industry is accelerating, and the frontiers have never been so vast.

In marketing, management is seeking more than ever to anticipate the market, to know more about its customers' needs and motivations than they know themselves, to guide research and development to meet predetermined needs of the market, and to achieve complete distribution of an ever-increasing flow of new products. The economist, the marketing research specialist, and the statistician are teamed with engineers, scientists, and mathematicians to refine the marketing factor in the management equation to a more exact point. New tools are being developed to aid management in its evaluations. Some of these tools, such as input-output techniques and the application of high-speed electronic equipment to business operations, constitute almost a new approach to corporate economics.

In human relations, management is seeking new ways to appreciate, understand, and evaluate motivations, reactions, group dynamics, and human engineering problems, whether they involve workers, executives, customers, or the general public. The work of the psychologist, the sociologist, and the human engineering specialist is being recognized and used by industry. Applied research in the social sciences, long

far behind fundamental research in the nation's universities and research centers, is being extended throughout the business world. Management can never afford in the advance of technology to decrease its attention on the human factor--a criticism often levelled against the corporate entity as it progressed during the early stages of the Industrial Revolution.

The effectiveness of communication, the quality of leadership, the temper of employee morale, the adjustment of men to machines and of machines to men, and the significance of the working environment can be analyzed, interpreted, and predicted. General trends can be traced and reasons assigned; patterns of thought and action can be stated in figures; responses and preferences can be forecast.

The evidence that industrial operations are becoming more complex can be observed with relative ease. The important point, however, is that the rate of change is accelerating--a change brought on largely by technology. The increasingly dynamic nature of the management problem is in itself a new factor in the management equation. This trend brings an ever-widening and more urgent demand on the part of management for facts--economic facts about production costs and schedules, market potentials and requirements, inventories and prices; - technical facts about new products and processes; - and social science facts about people and their patterns of behavior.

It might be worthwhile to mention some of the actions management has taken over the years to adjust itself to changes which have occurred in the problems at hand. During the past few decades there have been a number of attempts by industry to meet some of its problems at the management level, either by centralizing or by decentralizing the responsibility for major decisions. It is curious that there seem to be several definite shifts in policy on this question. Events during the relative recent past illustrate the point. Before the last war, there was a tendency for large corporations to centralize authority and responsibility in a single top management group. Following the war, an underlying move existed toward decentralization of many top management functions--of moving the management function closer to the source of facts. In recent years there seems to be a shift toward greater centralization brought on in large part by the need for speed and unity of action dealing with government and labor, and in the need for concerted action on many technological and marketing problems. One evidence of this centralization movement is to be found in the increasing number of companies now organized into divisions as opposed to the wholly-owned subsidiary device. Changes of this sort have an obvious effect upon the flow of factual data up the channel of authority within a company. They also reflect management's attempts to deal with shifting problems.

The rise of the comptrollership function over the past few decades has been in response to management's increasing need for coordinated and analyzed facts on over-all operations of the enterprise. Some large

corporations now have sizeable groups devoted solely to the collection, analysis, and presentation of facts useful to management for control purposes.

Another adjustment in the organization of management is the increasing extent to which research and development occupies a position in the top councils of large corporations. Often now, the director of research of a large industrial organization is an officer of the corporation. This has given rise to the saying that "the research director of a company is the vice-president of the future." The cases are increasingly rare in which the research function of a corporation is subsidiary to one of the other functional elements, such as production. Simultaneous with emergence of the research viewpoint in management's thinking has come an increasing emphasis on the principle that scientific research must stand the tests of economics. Management is insisting, that "proposed research programs must first be pushed through the economic keyhole." The implication, so far as techno-economic facts are concerned, is obvious.

In attempting to achieve a more efficient operation to go along with the increasing complexity of industrial affairs, management has also given serious thought during recent years to the size and location of its organizational units. We hear more about the problem of size versus morale and efficiency. Some companies have taken the position that definite limits should be placed upon the size of a single operating group. Others are striving to place parts of their organization in suburban settings.

It is a curious fact that, while tremendous advances have been made within industry to increase the efficiency of operations in the major functional areas--production, research, marketing, etc.,--equivalent advances have not been made in the techniques for handling the routine facts of business operations. The volume of factual data mounts--the need for factual analysis grows greater--the demand for precision continues unabated. But, by and large, management has had to meet the problem with the same mechanical aids used by a growing army of administrative and clerical employees. The "clerical problem" is becoming a matter of great concern in industry. This situation gives a sense of urgency to the widening applications of high-speed electronic equipment on industry's data-handling problems and their information-processing systems. The possibilities appear to be tremendous--the results far-reaching. If the rate of progress continues for some time in the future as it has since World War II, it is conceivable that future business historians will know this period as the beginning of the "administrative revolution." If the trend continues, a new factor in the management equation will most certainly have been created.

There is one other important development which deserves some attention in reviewing management's attempts to improve upon the evaluation and correction process. Facts alone, no matter how great the volume or

how timely, are insufficient to meet the basic problems created for management by the accelerating change in industrial affairs. Even with greater precision in the accumulation of facts, the problem of analysis still remains. It is one thing to reduce errors in the facts received from varying sources -- and another thing, to reduce errors in evaluation and decision, wherever possible, to some calculated probability.

To meet this need, the technique of operations research is finding a practical application in business. Operations research has been defined as "application of the scientific method to the study of the operations of large complex organizations or activities in order to give executives a quantitative basis for decisions." Several words in this definition are significant to the theme, "new equations for management,"--scientific method, complex organizations, executives, quantitative basis, and decisions.

The very essence of operations research is a mathematical analysis of facts on complex operations. A mathematical concept employed frequently is the theory of probability. Many business operations are repetitive, but operational results may vary depending upon elements of chance. Often, it is essential to measure the extent of these variations and the probability that they will occur in the future. This is done by constructing a mathematical model for the problem being examined.

The particular advantage of an operations research approach, beyond the facts which it develops, is that the problem and its possible solutions are presented to the executive in a systematic way, so that he has the situation clearly and completely before him. He can select an optimum course depending upon the goal he wishes to achieve. At the same time, he may have some measure as to the probable correctness of his decision.

Perhaps a completely satisfactory answer to management's continuing need for a greater and greater volume of more accurate facts will never be achieved. However, we have learned much about techniques of collecting, analyzing, and presenting facts from experience to guide us in decisions affecting the future. We must search for still better techniques to provide management with the facts it needs when it needs them-- and we must seek new methods of using empirical data as a basis for decisions by management. We must, in effect, defy Aristotle, of whom it is said:

"He could see no order in the chaotic appearance of experience. Facts (to him) occurred one by one in a seemingly unrelated fashion. Particular events . . . were an impregnable mass of occurrences without definite meaning. He did not understand what we call today . . . the theory of probabilities."

The really new factor in the management equation today is an increase in the rate of change toward greater complexity in industrial life. We must meet the challenge by giving management evaluated facts to overcome what might otherwise be "an impregnable mass of occurrences without definite meaning." Computing devices and information-processing systems have a major contribution to make in the gathering and evaluation of facts.

Applied research is directed to the production of facts for the management equation. The formulation of the equation, its expression, and its solution must remain with management itself.

SESSION III - PANEL DISCUSSION

An Evaluation of Analog and Digital Computers.

MODERATOR - Professor G. D. McCann
California Institute of Technology

PANEL - Dr. John L. Barnes
Assoc. Director of Electro-Mechanical
Engineering Department
North American Aviation, Inc.
Downey, California

Floyd Steele
Vice President in charge of
Engineering
Digital Control Systems,
La Jolla, California

Dr. Louis Ridenour, Vice-President
International Telemeter Corporation
Los Angeles, California

Dr. A. W. Vance
Research Section Head
RCA Laboratory Division
Princeton, New Jersey

CHAIRMAN McCANN: As you know from the program our panel of experts is to present an informal discussion this afternoon on the state of this rapidly developing field of machine computation. I think that we have succeeded in bringing together four people with as broad a field of experience and knowledge of this subject as possessed by any four persons that could have been chosen.

I would like to begin this meeting by first introducing them to you, and I will start with John L. Barnes, on my far right, Associate Director of the Electro-Mechanical Engineering Department, North American Aviation, Inc., Downey, California. Next is Floyd Steel, Vice President in charge of Engineering, Digital Control Systems, La Jolla, California. On my left is Louis Ridenour, Vice President, International Telemeter Corporation, Los Angeles, California. On my far left is Arthur W. Vance, Research Section Head, RCA Laboratory Division, Princeton, New Jersey.

It is extremely interesting to note the background of our four experts. This is a very new field, as you know. We are not formally training computer people in the schools on any extensive basis and have not given courses on computer development or applications until very recently. The people therefore who have made notable contributions to this field have started their careers in other activities.

Dr. Barnes is well known in Southern California. He started out as a mathematician and electric engineer. He obtained his SB and MS degrees, in Electrical Engineering at M.I.T. Then he decided to take up basic mathematics and went to Princeton University to obtain an AM and PhD in Mathematics. He then went back to M.I.T. to teach in a field for which he is well known; linear circuit theory and its applications to feed-back systems. After a year at M.I.T. he went to the Mathematics Department at Tuft's College where he became the head of the Applied Mathematics Department. Also for a short period he was head of the Electrical Engineering Department there.

During the war he spent some time at the Bell Telephone Laboratories working on microwave guidance problems and gun directors. He went back to Tufts for a short period after the war and then came to U.C.L.A. as Professor of

Engineering. I imagine that perhaps his interest in circuit analogies and his war experience with gun directors, started him toward the computer field. Now his experience is being applied in the aircraft industry. At North American he is guiding very broad phases of development and application of computers and complete systems for the aircraft industry.

Dr. Louis Ridenour started as a Nuclear Physicist. He received his Bachelor's Degree in Physics at Chicago, and his PhD at the California Institute of Technology. He went to the Institute for Advanced Study to work in the nuclear physics field. After a short stay there he went to Princeton University still interested in research as a physicist; then to the University of Pennsylvania as Professor of Physics. At the formation of the Radiation Laboratory at M.I.T. he was asked by Dr. Dubridge to act as an assistant director of the laboratory, where he is probably best known for his work in editing the Radiation Laboratory Series of publications. Following the war he went to the University of Illinois as Dean of their Graduate School. Probably his work at the Radiation Laboratory, his close association with the problem of guidance and control is what started him thinking about computers. In any event, even though occupied with duties as Dean of the Graduate School at Illinois, he nevertheless became sufficiently interested in the computer field to instigate several research projects there, and apparently convinced himself that the computer field was such an important one that he should devote his major interest to it.

Floyd Steele obtained his BA degree at the University of Colorado in Physics and his Master's Degree in Aeronautical Engineering at the California Institute of Technology. He first got into the computer field through his work at Northrup where he went to work on a long-range missile guidance study. This led to the need for special computers and he is well known for his development of the Maddida. He is one of the inventors, I believe, of that device. This became such an interesting activity to him that he thought it sufficiently important to leave Northrup and set up his own company, Computer Research Corporation. He formed this company and acted as its President for one year. He then left to form another new company of which he is now Vice President in charge of Engineering, Digital Control Systems.

Dr. Arthur W. Vance is an electronics man, one of the pioneers in the electronics field at RCA. He received his college education at Kansas State and his background as I said, has been primarily in electronics ever since. He has contributed much to the development of facsimile and television in the last fifteen years and during the war worked on the application of electronics to the guidance and control systems of gun directors. He was also interested in the design and development of special feed-back systems. He is probably best known to us for his valuable contributions to the Typhoon Project Computer at RCA.

That is the background of our panel of experts.

I would next like to give you the rules under which we are going to conduct this meeting, because as you know a subject of this kind can be controversial to the extent that we might not be able to cover all of the subjects planned. There are going to be a number of points of view on each

topic and to provide the maximum of information to you with the minimum amount of time available, we are going to follow this procedure. We are going to first ask each of our experts to present a formal talk which will outline one of the four main phases into which we have divided this subject, to give you the scope of the field as we see it. This will allow you to sit back and think about the subjects as they are being presented and to formulate any questions you may wish to ask this panel of experts. We are going to ask that these questions be written on cards. At any time anyone who has a desire to write down a question may raise his hand. There will be three attendants watching for raised hands who will immediately bring to you a card upon which you should first put your name, your affiliation and then the question you wish to ask.

Following these four formal discussions by our experts we probably will find it desirable to have a short intermission. This will give you a little more time to formulate any questions on the subject matter being presented. When we reconvene, I will submit these questions to our panel of experts for their answers and general comments. These then are the rules under which we are going to conduct this meeting.

Now we believe that since this field is so broad, we ought to develop the subject formally by first defining it together with the important developments that have taken place. We will do this in a series of four parts. I will ask Louis Ridenour to lead this session off by defining the scope and terminology of the subject of computers. Dr. Ridenour.

Introduction: Definitions of Terms and Scope of the Discussion

The topic to be discussed this afternoon is one which has been the subject of many informal and often heated discussions. There are engineers who have a violent preference for the use of computing machines of the analog type for the solution of almost any problem; conversely, there are those who are equally firmly convinced that nothing except a rather rudimentary state of the art prevents the use of digital computers in practically every application. Your panel hopes that our discussion can be conducted on a more modest plane with a view to reaching some sensible conclusions about the relative properties of these two types of machines and the general uses to which each type can be put. Let us begin with definitions.

By a computer we shall mean a machine for the processing of information, whether or not the nature of the problem being handled involves actual arithmetical computation. That is, we shall not exclude from our discussion the use of a computing machine for the purposes of performing a clerical or process-control operation of a practical sort. This being the case, it might be better to refer to the computer as an information machine, or information-processing machine, since this, and not merely computation, is the broad definition of its function. However, since the word "computer" has been used in the program, we may as well continue to employ it, understanding that its significance in the present connection is only to differentiate the machines we are talking about, which handle information, from power machines intended to perform some sort of physical work.

Also implicit in the word computer, as we shall use it, is the idea that the machines we are interested in are automatic in operation. That is, we do not propose to debate the relative virtues of the digital desk

calculator and that prototype of all analog computers, the slide rule; instead we shall be discussing the properties of digital machines capable of executing more or less complicated programs of sequential operations, and analog machines such as those constructed for the purpose of simulating the flight performance of aircraft and guided missiles.

Everybody knows the distinction between the analog and the digital machine, but for the purpose of comparison in this discussion, I remind you of the difference. An analog computer works by transforming, in accordance with its construction, input physical quantities measuring the variables of interest into the output physical quantities which represent the solution of the problem being solved. The analog machine is itself a physical analogy to the problem it handles; it works by measuring the magnitudes of the physical quantities such as shaft rotation, electrical resistance, frequency, etc., presented to it as measures of the magnitudes of input variables. Output information also appears as the magnitude of a physical variable or variables.

In the digital machine, on the other hand, the value of a variable is represented not by a single physical magnitude, but instead by a series of digital representations which correspond to the digits of a number in the number system appropriate to the machine. To work at all, a digital machine must measure, transmit and transform actual physical quantities which represent the digits of the numbers being processed, but the significant point here is that the measurements made to determine the number corresponding to a particular value of the physical quantity in question need not be particularly precise. If the machine works in the decimal system, we need to distinguish among ten possible states of the physical quantity used to represent a number. A precision better than ± 5 per cent will enable us to do this unerringly. If the number system used by the machine is the binary system based on the radix 2, then we need distinguish only between states which can be described as on and off. Precision in the representation of a quantity is obtained in the digital scheme through representing the quantity by a longer and longer succession of digits; precision is obtained in the analog scheme by increasing the precision of the actual physical measurements performed.

Because of this difference in the basic operating philosophy of the two types of computing machines, there is a corresponding difference in the best region for the application of each type to information-processing problems. We note first that the measurement of any physical quantity can be performed only with limited precision. Under actual field conditions it is difficult to make measurements precise to more than perhaps one part in a thousand, or $1/10$ of one per cent. Under average laboratory conditions, it may be possible to attain one part in 10^5 ; while even the most carefully controlled measurements made by standards laboratories rarely attain precisions better than one part in a million when direct measurement of a physical quantity is involved. When the measurement can be made by counting, as is the case, for example, with time and frequency comparisons, much higher precision is possible; but this, of course, is a digital technique. As a rough rule of thumb, we can see that a well-made analog computer should be good to about one tenth of one per cent; and that this precision can be improved about one order of magnitude by taking pains. For problems which require greater precision than this, the use of digital methods is indicated.

Since an analog machine is in fact a physical analogy to the problem it is solving, when the problem is a simple one the computer can be simple, too. This represents a genuine advantage of analog methods for solving simple problems, because the minimum automatic digital computer is still a fairly formidable device whose complexity will be fully justified only when the machine is used to handle reasonably complicated problems.

Another advantage of the analog machine derives from the fact that it works in what is called "real time". If input data are supplied continuously to the machine it will generate continuously a solution appropriate to the current values of the input variables and to their past history, with a time lag which is governed only by the frequency band in which the analog machine is designed to work.

In the case of the digital machine, any problem that it handles must be formulated more or less explicitly before the machine can tackle it, and several or more individual steps of computation may have to be performed for each sampled value of the input variables entering the problem. Under these circumstances, it will happen that the machine is sometimes too slow to keep up with the flow of input data.

This will occur when the time between samples of the input variables becomes shorter than the time necessary for the machine to execute all the computational steps which must be performed on each new value of those input variables. In the early publicity releases on the ENIAC, the first of the electronic high-speed digital computers, much was made of the fact that the machine could solve the problem of a shell's trajectory from a gun to target in a time less than it required the shell to make the trip. That is, the ENIAC was able to solve this ballistic problem in real time. In some of the more complicated flight problems involving control, even the most modern machines are unable to operate in real time. The fastest machines of the present day are roughly an order of magnitude too slow to handle the complete problem of the simulation of the flight of a high-speed guided missile.

It is sometimes asserted that another advantage of the analog machine is its ability to incorporate as a part of the over-all analogy to the problem various sub-assemblies which actually belong to the system being studied. That is, in the case of the simulation of missile flight by an analog computer, we can simulate the performance of an auto-pilot by actually putting the auto-pilot itself on a tilt table which is "flown" in accordance with the conditions of the simulated flight. Output signals from the auto-pilot are then fed into the system in the appropriate way. When this is done, it is clearly not necessary to know the transfer functions of such a device in any explicit way, since the device itself is present at all times to speak for itself. In systems involving human operators, it is especially convenient to make use of this technique, since the pertinent transfer functions of human beings are usually very imperfectly known. While this technique of incorporating sub-assemblies into the system has been used presently in connection with problems handled by analog machines, there is clearly no reason why a digital computer operating in real time could not make use of precisely the same technique. It is true that equipment for performing digital-to-analog conversion would be necessary to control the environment of the sub-assembly, and that analog-to-digital conversion equipment would be required to render the output signals of the sub-assembly intelligible to the digital computer, but neither of these requirements presents any difficulty of principle. People are simply

not accustomed to doing real-time computations on digital machines, so that this technique has flourished principally in connection with analog simulation. As digital machines increase in speed, we can expect that simulation which includes this technique for the avoidance of explicit analysis through the use of sub-assemblies will be of increasing importance.

Digital computers available today are deficient not only in respect of the speed necessary to handle complicated real-time problems, but also in terms of the sort of input and output equipment that will be required to fit them for application to other than straightforward numerical problems. The present fact seems to be that digital computers are so extremely useful for computation that they have been used for little else. The natural trend in this direction has been accentuated by the fact that the terminal equipment required for input and output is very simple in the case of a numerical problem and considerably more complicated and special in cases in which information of other sorts is to be gathered, processed, and used. The real-time flight simulation already mentioned is one case in point. Arrangements for incorporating actual parts of the mechanism into the simulation set-up will be necessary if digital machines are to be used in such an application, but many other examples come immediately to mind. If a digital machine is to be used for industrial process control, for example, it will have to obtain its input information from transducers and analog-to-digital converters of a sophisticated sort. The exact nature of these devices will be dictated in detail by the requirements of the application. Very little work in this direction has yet been done. The resulting scarcity of terminal equipment permitting the application of digital machines to problems more general than computational ones has given many people the notion that something in the machine itself renders it unsuitable for this sort of application. This is almost certainly not the case; it is my expectation that we shall see a substantial and rapidly growing application of digital machines to all sorts of non-arithmetical information-processing in the immediate future.

What is interesting to note about this prospect, however, is the fact that its realization will require an intimate marriage of analog and digital techniques. In general, the input information required in such an application of a digital machine will reside in the values of some physical quantities which must be measured in an analog fashion. The results of this measurement will then be translated into digital form for input to the machine; and the digital output of the machine must be translated back again into analog quantities involving the motion of control levers and the like. It thus makes very little sense to debate the comparative merits of the two information-processing techniques. The practical information machines of the future will involve such an intimate mixture of digital and analog techniques that it is not likely to be sensible to inquire whether one of these is in fact preferable to the other. They are complementary techniques, in the sense that the information machines of the future must be compounded of both.

CHAIRMAN McCANN: Thank you, Louis. We have arrived now at a definition of the subject of this afternoon's meeting. We now come to the second phase of our four main subjects, "The Role of Analog and Digital Computers in Simulation." This will be presented by Arthur Vance.

The Role of Analog and Digital Computers in Simulation

Simulation is a technique for obtaining the solution to the differential equations that represent some complicated physical system. These differential equations usually defy solution by classical methods because of the nonlinearities and of the empirical relationships involved. As the physical system becomes more and more complicated, the solution becomes increasingly difficult. It becomes infeasible to simply avoid the complete solution by using intuitive processes to guide the design, build the equipment and then test and "debug" it because the guesses made this way are often worthless. The detailed equations must be solved at almost any cost.

Simulation may be accomplished by two general methods--physical simulation and mathematical simulation.

Physical simulation is a kind of model testing technique. A good example may be found in the methods often used to determine the overall performance of an autopiloted missile or airplane. Since airplanes and missiles are very expensive to test by actual flight, it is attractive to try to duplicate the motions of the airframe by some ground borne device and attach the autopilot to this device. Then many non-destructive tests may be made while the autopilot is adjusted to obtain maximum system effectiveness. If this can be done, it may be possible to obtain optimum performance without knowing in complete detail how the autopilot itself works and a test of the actual gear itself is obtained. This is a powerful method and is and will continue to be used where possible. The difficulty lies in the physical device which provides the airframe motions. The lateral velocities and accelerations cannot be provided, so at the outset many of the advantages and assurances of the method are lost. The device must work in real time so the dynamical difficulties increase rapidly as the performance of the simulated airframes increases. These mechanical difficulties also increase rapidly as the number of degrees of freedom increase and the number of gimbals required multiply. The whole story of physical simulation is far too complicated and extensive to cover here. The general trend seems to be away from physical simulation for the detailed solution of the large, fast and complicated systems because of the mechanical limitations involved in the construction of the flight tables. The situation is relieved somewhat by the fact that as knowledge increases, more and more is becoming known on what the "black boxes" contain and appropriate mathematical simulation techniques developed.

Mathematical simulation simply means obtaining a solution to the equations. This may be done by any appropriate method and does not require a real time scale. Many years ago the difficulty of solving nonlinear differential equations by hand was encountered and the mechanical differential analyzer was developed. The device is still a valuable tool today. The mechanical machines, while very slow by modern standards, were largely unchallenged by digital hand calculation methods for many years. The evolution of the modern electronic amplifier, servo multiplier type of computer during the last war, primarily as an outgrowth of fire control computer developments, caused somewhat of a revolution in the differential analyzer art. At nearly the same time the modern electronic digital computer was born in the form of the ENIAC. This development at the University of Pennsylvania, sponsored by the Army, sprang primarily from attempts during the last war to develop digital fire control apparatus. Electrical relay computers had been developed into useful medium speed computing facilities by Bell Telephone Laboratories

and Harvard University a few years earlier, but did not fire the imagination to the extent that the ENIAC did. The seeds of a stimulating and sometimes acrimonious controversy were sown. The electronic analog computer on a small scale was rapidly developed into a very useful commercially available device by Reeves Instrument Company, followed by Goodyear, Boeing, Electronic Associates, Philbrick, and others. In the large computer simulator field Reeves started development of the Cyclone Laboratory and RCA began the Typhoon under Navy Department sponsorship. The DACL of M.I.T. developed a large physical simulator with considerable mathematical simulation capability, also under Navy sponsorship. Two large network type machines springing from a different ancestry appeared at Westinghouse and Cal Tech, and provided useful computation capacity in a somewhat different area. Meanwhile a sizeable combination physical and mathematical analog simulation center was developed at the Bureau of Standards, primarily under Navy sponsorship. The birth of the electronic digital calculator was greeted with great enthusiasm and it was proposed as the obvious solution to all computing problems. Many of the proposals were not supported by the required detailed study of the particular problem to be solved. It would seem that many people did not take the time to investigate the effective computing speed and capacity of analog computers, nor to consider the many pitfalls in the tedious step by step integration processes that digital machines must use in the solution of differential equations. At least one large scale digital computer project was started with the intent that it would become a large-scale simulator operating in real time or faster than real time. It developed that one difficulty lay in an unexpected direction--that of speed--the most talked of advantage of electronic digital techniques. This project has long since been diverted to more useful fields, but is occasionally used to solve a test problem for simulators on a greatly extended time scale. This does not mean that digital simulation is completely out of the picture, but merely points out that simulation is an especially difficult field for a general purpose digital computer and that special machines will have to be developed if a purely digital simulation facility is to be able to carry the main work load of simulation problems. Digital techniques have not been discarded as future possibilities for large simulation problems. One interesting project is under way at the University of Pennsylvania, under sponsorship of the Special Devices Center of ONR, for its development of a digital flight trainer. The accuracy requirements of this project are less than for simulators and simplified integration techniques show promise of a reasonably practical solution.

In the field of small scale simulation, digital techniques and machines could be used to handle the main load if a big machine were used for a small job. An interesting development is the digital differential analyzer of the Maddida type which, because it is programmed somewhat like an analog machine, is easier to set up for this kind of work than other types. It does not appear to be competitive in speed, however,

It is obvious that both analog and digital techniques should be teamed up to obtain the most effective overall combination to handle the work load. Even though real time solutions are not mandatory for mathematical simulation, the work load is so high that seriously extended time scales of 100 to 1 or higher cannot be economically tolerated. Present digital machines, in order to solve large scale simulation problems, require time scales of this order or higher and so are not economical. The main use of digital techniques is that of applying check problems. These problems serve to verify that the program has been properly set up and to indicate the accuracy obtained. It is often very difficult to predict the accuracy of an analog solution.

Most small scale analog computers now have available facilities for storing problems on plug-in plug boards. This makes it easier to plug in a test problem and make checks more often. Other trends in their field are improved multipliers (in some cases electronic time division types) and better and more flexible function generators. Overload indicators and drift indicating devices are becoming common and are proving very useful. In general, the situation in the small simulator field is satisfactory.

The most difficult problem exists in the field of large scale simulators. These devices use and require a large volume of equipment which in many cases must be more accurate than that necessary for small problems. Because of the large number of units that must be checked out and properly interconnected, problem set up may require weeks to complete and prove in. Digital check problems are a necessity in this field and it requires as long as several months to program, compute, and verify a single check problem. All of the large simulators are making increasing use of digital check solutions. Often the customer supplies his own check solution. Soon each of these installations may require nearly full time use of a medium size digital machine. Most available digital computers do not have enough fast memory to operate at full speed for these problems. Maintenance is a major problem because there is so much equipment that must be operated simultaneously. Even though a high degree of reliability can be maintained in the individual components, the effective overall useful operating time is often unsatisfactorily low because it is so difficult to locate and find faults in programming and in faulty components. The main loss of time is taken up in diagnosis. The problem is complicated by the wide variety of components that make up these machines. The linear, functional and sine cosine servos are usually a problem. It often happens that some of the servos require considerable modification to obtain the best compromise between speed and smoothness.

A more fool-proof interconnecting and gain setting system is vitally needed, as is a method for storing problems. An automatic system for testing components and locating faults rapidly is necessary.

All of the large simulation installations are aware of these problems and are doing what they can to alleviate them. A rather large scale simulation system has been assembled at the Consolidated Vultee Company in San Diego, and I understand that they expect to install a device developed by Electronic Associates wherein about 500 potentiometers can be accurately set against a single precision voltage divider.

The Bureau of Standards at Corona is experimenting with a somewhat fool-proof interconnecting scheme wherein the problem is stored as punch holes in cards and an operator merely fills up all open holes with special spring connected patch cards.

RCA Laboratories is developing a new large scale mathematical simulator for the Wright Air Development Center of the Air Force. The plans call for this device to take full advantage of the RCA time division multiplier and so eliminate all servos. The elimination of all internal mechanical parts is expected to permit much faster time scales (real time in most cases) and greatly reduce maintenance problems. All trigonometric transformations will be made by mathematical formula using multiplication. The device will contain over 200 multipliers and will use about 900 DC amplifiers, most of

which will be used in the multipliers. A system that will automatically and rapidly check the zero, linearity and scale factor of all the multipliers from the console is under development. Plans are under way to provide punch card controlled interconnections and gain settings by means of a crossbar switching technique. All of the connections will be completely shielded from each other. This involves the use of about 150,000 special switches or connectors. The development of this system is at an early stage so few details can be given at this time.

Experiments are under way on an electronic chopper to replace the vibrators used to stabilize the DC amplifiers. This system, which uses back to back photo cells excited by a glow tube, was just developed by the Cambridge Air Force Research Center.

CHAIRMAN McCANN: Thank you, Arthur. Mr. Vance has covered certain very important phases of this state of the art. I think some of the other aspects of computers as they have now been developed and are being thought about for the future will come out in some of our future discussions here this afternoon. Arthur has touched upon one point which I think is worth emphasizing. That is the fact that those of us who are developing computers find ourselves in many instances trying to develop a device without knowing completely and precisely what this device is supposed to do. This is not facetious. A working model must be used extensively before its complete application and best method of use can be determined. This then provides a basis for redesign of the computer into more useful form. This situation is particularly true in the application of machines to engineering analysis where a large part of the problem lies in the determination of the proper way in which to use computers. From this knowledge then will come the better design of such computers.

Floyd Steele will now discuss this subject from the standpoint of the evaluation of functional applications and processes. Floyd Steele -

An Evaluation of Basic Machine Processes

During the last decade, several developments in the computer art took place which appeared to have implications of far reaching consequence to science and engineering as well as to other fields. These were the development of electronic means of storing and manipulating numerical data, the discovery of new logical processes for computers to follow in performing general computation, and lastly, the recognition of the central nervous system as an electronic digital device.

The discovery of radically better ways and means to perform computation indicated that practicing science might soon expect to free itself of dependence upon analytical mathematical models, while engineering could cope in daily life with non-linear situations, elaborate geometries, and interacting systems.

The unexpected inclusion of animal mechanisms somewhere within this field came as a surprise to which no one has as yet made an adequate response. However, the intertwining of the general computer activity with the human brain now gives to the whole automatic endeavor a delightfully mysterious and somewhat sinister public repute.

Although there is general agreement that electronic devices will lead to broad changes in the techniques of science and engineering, it is evident that as yet no general revolution is in progress, although there have been a few revolting developments.

Nevertheless, if we select any representative number, such as total people employed or total dollars spent, which can characterize some part of the computer activity and we fit the last ten year interval with any standard growth curve, we find that in nearly every instance we are on the lower limb of the curve, well below the reflex. Computer activity is obviously increasing and at an accelerating rate. The chief deterrent to greater activity is still the economic one. Machines are too expensive for average users.

It is worthwhile, perhaps, to consider some of the basic difficulties underlying present day computer developments, and to consider various directions in which they may be resolved.

Much of the impetus for computer development has come from a few universities and from the Bureau of Standards. In these organizations a number of large and high-speed general purpose computers and some analog machines have been made and are now employed both in solving particular problems and extending general theory and technique. This work has laid a broad foundation for large scale application and has pioneered in much component development, but has always emphasized speed rather than simplicity.

Since machines can never be too big or too fast to cope with the ultimate problem, it is intelligent to expect that publicly supported machines will continue to evolve in the direction of still greater speed, cost and complexity as warranted by present demand and new components. These machines must ultimately become our national wind tunnels, weather predictors, missile simulators, etc. In the first round of publicly supported machines, the rendering of generalized computing service has been a chief goal, hence the general purpose computer has been greatly stressed. In the next round, now under way, individual centers will probably tend to specialize in particular problems of great size. Generality of application may well be de-emphasized as of lesser importance.

In the large, technical industries, such as aircraft, a rapidly increasing amount of both research and engineering computation is being performed, nearly all of it on either IBM punch card machinery, or REACS, in either case using extensions of standard techniques.

A large part of this work is not, however, indigenous to the normal growth of American engineering but rather reflects military subsidy.

If our real difficulty is the economic one, it in turn stems from a lack of knowledge of the means of utilizing new devices to achieve simplicity, reliability, and low cost. It is apparent that such features are more natural to digital electronic components than are high speeds. For example, a single channel on a magnetic drum may conceivably record between 4,000 and 6,000 bits of information with about eight or ten active elements serving as proprietors of the record. The cost and reliability is represented by eight or ten, the complexity of response by 4,000 to 6,000. Moreover, the data is normally available in a form which can be readily communicated with like units either in the immediate environment or on commercial wires. This represents a new advent in basic mechanism--a device which achieves many units of complexity for each unit of equipment. The discovery of the magnetic memory would seem

to imply that an extraordinary simplification of existing mechanisms is possible.

Our failure to achieve simplification to date is due in part to a lack of knowledge of the logical processes which will permit us to make use of memory to achieve simplification. This type of difficulty also manifests itself in the coding of engineering and scientific problems for machine computation.

In the actual day to day utilization of large scale mathematical computation, several rather unexpected developments have appeared. Among them is the de-emphasizing of the mathematics and physics concerned. We may distinguish two phases in the solution of a large problem, calling them for convenience, the strategic and the tactical. Strategy normally consists of setting up the appropriate physical equations involved and determining the range of parameters, initial conditions and other relevant magnitudes. The tactics take place in the translation of the equations into practical machine processes. One would normally expect that a great wealth of analytical work would be brought to bear on the problem, since so much has been applied in the past, yet the contrary seems to be quite generally true. For example, in the tactical work it is not common practice to do much analytical error estimating. Instead, runs using various sizes of the discrete intervals are often made.

Again simple integrating and interpolating formulas are used rather than the elaborate ones set forth in the texts. The reason is often that the steps of actual computation are imbedded in a serial routine along with counting and testing steps. The calculation advances one interval by cycling once around the routine. If a simple numerical formula is used, the routine becomes short, more cycles may be carried out in the same length of time, hence a smaller interval can be used. The smaller interval both tends to recover the accuracy and to make the computation better behaved near critical points of various kinds.

Even the strategic mathematics, the physical equations themselves, are not being done very analytically when sufficient computing equipment is available. It is often convenient to start with a standard, linear approximation whose behavior is well understood and to add non-linear elements one by one, observing each time the empirical agreement of the computed consequences with the real situation. This represents an unusual form of function fitting. The intent here is not to develop a mathematical model which describes the real world, but rather to find a computing machine process which imitates it accurately.

It is at this point that we begin to perceive the direction of the difficulty. In the past four hundred years mathematics and physics have been largely interested in studying the general types of relationships which exist between or among variables and in identifying these variables with physical phenomena.

In this period no major attention was given to the study of logical processes. In school we were introduced to the symbolic relationship of multiplication early in algebra and soon became mechanically proficient at manipulating this operator with others to form elaborate relationships. Much earlier in school, however, we learned a logical process for performing the actual multiplication of two real numbers. This total process was conveyed grammatically to be applied by rote.

Now there are actually a number of ways to perform valid multiplication, some of them unusual enough to be used for parlor tricks. Yet there appears to be no general, fluent technique for placing these various processes into an operable notation and showing their equivalence. Number theory can, of course, be used to prove the point but not too usefully. What we will need is a set of simple, rote processes which will enable us to make permissible alterations of sequences of operations, cancel redundant terms, substitute equivalent ones, etc. In short, a process for operating on a process.

The coding of machines has led to the widespread use of flow diagrams very similar to those long developed by industrial engineers. Flow diagrams convey the notion of operation sequence and branching but are not easily operated upon. At present, machine coders are preparing libraries of subroutines pertinent to their machines. These are standardized processes which can be placed in the machine as direct substitutes for either standard functions or for operations not basic to the computer. They represent a convenience rather than a logic, however,

It is probable that an adequate science of process as yet relatively undeveloped, will supply a very important element in long range progress. Such a science will have to discard many of the present outlooks and interest of mathematics and physics, identifying the broad uniformities of the real world directly with basic logical processes, elaborating these into particular situations with some process logic or process process, and manipulating the whole with machinery.

Until such time as a formal science of process becomes available, however, we will have to proceed by enlarging our stock of useful machine logics and maxims.

As of today, we have several rather basic digital processes available. The requirements of a useful rational process are that it consist of a sequence of simple operations, each performed upon like things. A useful operation, in turn, is one having two inputs and one output, the output being formed from both inputs. It is very desirable to have inputs and outputs of the same nature, otherwise the complexity which can be achieved by successive operations is severely limited.

In a general purpose machine, the like things which we choose to operate upon are numbers. We collect two numbers at a time from the number file or store to serve as inputs to a central operation. The output, also a number, is returned to the file, hence is available as any subsequent input. In the various address systems, numbers may be picked up one at a time instead of two, or returned to the file only as called for, instead of automatically.

The basic machine maneuver however, is always that of gathering individual numbers from any place in the memory into a central spot for assembly by pairs into another number and the return of that number to the memory. It is this freedom to gather and dispose of numbers which gives this type of machine great flexibility.

There are many practical situations in which this unlimited communication with the memory is far from economical. In all of those scientific and engineering problems involving continuous situations in geometry, force, and time, it will normally be found that most numbers involved only

enter into operations with one other number, hence that permanent pairing should form the basic process. In such a machine the moving of numbers from pair to pair can be conducted as a special rather than standard operation, or numbers which occur in more than one pair may be repeated. The punch card machines operate by this basic maneuver. A pair of numbers, presented to the machine by a single card, are operated upon with the result being placed back in the card system. Whereas in the general purpose logic it is normal to use a single operation upon the two numbers, it is more useful in the paired number logic to perform a large sequence of operations at one time. It is interesting to note that even in the solution of the Laplace partial differential equation, the operations can be broken up so that the machine does not have to simultaneously collect the left and right and up and down points, hence can operate without regrouping.

A second situation in which the standard general-purpose logic seems redundant is again that in which a continuous situation must be solved. Under these circumstances, the machine, for economy should not use the relevant numbers as the basic units, but rather deal with their changes or differences. Each successive operation tends to alter the numbers involved by small amounts hence it should be unnecessary to move the entire number within the machine.

In many engineering and scientific situations we might gain machine economy by utilizing permanent pairs and at the same time transporting only the differences. No general machine of this sort is available. A special instance however, is the digital differential analyzer in which differences are restricted to unity. This type of machine has many similarities to the analog in its mode of operation, and logical parallels may be drawn between them. This parallelism results from the use of unit differences, rather than permanent pairing.

It is interesting to note the considerable economies which may sometimes be effected by changing the basic machine strategies. In automatic, continuous control applications for example, the general purpose machine must effectively supply a continuous sequence of unit changes to a set of actuators, hence in this application it compares directly with the digital differential analyzer in operation.

At the present time, digital differential analyzers cost a little less than half a tube per integrator, if we include read-in and read-out. Fifty integrators thus cost about twenty-five tubes. If a magnetic drum memory is employed, the logic of the device is such that each revolution of the memory advances every integrator in the machine by one increment. The act of advancing a single integrator is in turn equivalent to performing about five operations. If we turn the drum at the very moderate rate of thirty times per second, the analyzer will carry out about 7,500 operations per second, a speed somewhat less than that of Whirlwind.

This comparison, however, is not valid to make in comparing computation rather than control speeds. In computation, the general purpose machine may enlarge the interval and gain back several orders of speed, while the differential analyzer must continue with the same interval unless it sacrifices accuracy.

The example illustrates that one basic machine logic can often achieve great simplicity over another in a particular field of application.

It is quite probable that logical research will uncover a series of suitable machine strategies, each one yielding machine economy in a given field of application.

All of these logics can, of course, include decision making. The problem is more that of basic number maneuvering.

In the last year, the field of digital control has begun to separate from digital computation, the basic logical requirements becoming increasingly different. In this field, another digital process has begun to develop, that of computation without the use of numbers.

The basic "things" in this machine system which are combined are not numbers, but single selections. The output of any combination is in turn a single selection. So far, it has been possible to find processes for conveying an effectively continuous magnitude without the use of number and for effectively performing addition, subtraction, multiplication, and producing general linear transformations.

It is probable that such a logic bears reasonable similarity to animal control systems, since the latter also do not use numbers to accomplish control operations. Like animal systems, the non-numerical control operations are not seriously disturbed by moderate amounts of internal noise and also lend themselves to defined learning processes.

It may now be worthwhile to talk of a machine learning process as one in which the machine adapts its code of instructions to conform to its experience. Normally, the word "decision" has been used to describe the action by which a machine changes from one program to another and learning has often been discussed as the adjustment of a particular control parameter, by trial and improvement methods. Since in a numerical machine, the trial alteration of any instruction will tend to alter the entire process completely, it is not possible to gradually modify and improve code.

In non-numerical applications, however, the trial alteration of an instruction produces only a slight change in the response, hence, the machine may undertake a continuous alteration of its code in search of a better process of response.

In summary, we may conclude that the chief difficulty encountered in the rapidly growing applications of large scale computation to the problems of science and engineering is in the complexity and cost of the machines themselves rather than in their ability to solve problems. This situation fundamentally requires a new development in theory. Meanwhile, new basic machine processes may contribute considerable simplicity in various applications.

CHAIRMAN McCANN: We have now discussed definitions, the role of computers in simulation, and have evaluated basic digital processes. It is probable that we have not yet covered the specific phase of each of these that many of you want answered. If not, ask for a card and write your question on it so that we will be certain to cover it in the general discussion which follows this formal one.

Now it is of interest to next consider the manner in which computers or "information processing devices" have been utilized in a broad sense by one of the big industries of this country. The aircraft industry has been a pioneer in this respect. Nobody here is probably better qualified than John Barnes to summarize that particular phase of the subject for you.

INFORMATION PROCESSORS FOR THE DESIGN, TESTING & OPERATION OF AIRCRAFT

Introduction - As Norbert Weiner has suggested, we are now entering the second phase of the industrial revolution. The first phase consisted of the replacing of the power of men and horses by the power of machines. The second phase consists of replacing the more routine thinking of men by (non-human) automatic thinkers. This automatization of thinking is producing fundamental advances in the engineering, testing, and operation of aircraft systems.

Decreasing Crews - Let us first consider the present stages of evolution of aircraft. Bomber crews are going from 15 to 3 to 0. Fighter crews are going from 2 to 1 to 0. From the crewed aircraft we pass to the crewless aircraft through successive stages of approximation.

In this process we begin by automatizing the simpler operations, We design autopilots for cruising flight, automatically-tuned communications systems, and the like. Then we design drone aircraft which are flown from an accompanying mother aircraft. The next step is the crewless aircraft. Even in this step there will be a crew, but the crew may well be on the ground, or in a ship, or in a distant aircraft.

Information Processors - The automatic thinkers for these increasingly automatic aircraft systems I shall call information processors. These information processors must replace the thinking of the crew which was devoted to flying the aircraft. They must perform the proper functions with stability and adequate quality. They must exhibit the proper degree of indisturbability and reliability.

Processors for Design - Now if we can make information processors for flying aircraft, it is evident that we should make information processors for doing routine, boring, slow thought processes needed in designing aircraft systems. This revolution, or perhaps we should call it evolution, is taking place.

Autopilot - A really good aircraft system must be designed as a whole. Allow me to direct your attention to the design of that part called the autopilot. The final design can be approached through the following sequence of approximations.

1. After exploration of a set of promising aircraft configurations including autopilot, one is chosen. Then a classical engineering solution of the linearized equations is run through. Here the Laplace transformation and root-locus graphical aids are used to explore the proposed design.
2. The next step in approximating the aircraft-autopilot system is the synthesis of a full-scale dynamic model by using an analog computer such as a REAC. At this

stage it is possible to simulate certain of the nonlinear characteristics of the system.

3. As a further step toward the final system, autopilot actuators and control system replace their simulated counterparts in the analog computer. The actuators operate lumped-parameter rigid-mechanical hinge-moment simulators which take the places of the control surfaces.
4. There follows next the first airborne step in which the autopilot is checked out in a piloted airplane. The pilot can manually override the autopilot if need be in this stage. This may be the last step.
5. However, in the case of a crewless aircraft there is one more step. Here the autopilot is adjusted and checked out in the crewless aircraft.

In each phase the information learned is fed back into the autopilot design to improve the function, stability under the range of aerodynamic conditions, the quality of response to characteristic control signals, the load limiting behavior, and the reliability of operation.

Information Processors for Operation - Turning now to information processors for operation of the aircraft, it is seen that the typical problem is the processing of measured or communicated information to put it in a form to be used as actuator inputs. In an autopilot the input to the information processor may consist of steering signals, angles of attack, pressures, temperature, angular rate signals, structural strain signals, etc. The processor will properly combine these signals and send the amplified output signals to the propulsion system and to the aerodynamic control surfaces.

In matching the information processor to its task the designer is concerned with the measurement and statistical description of the expected set of input signals, the rate of information flow, the amount and duration of information storage, the accuracy of output and input signals needed for the job to be done, the statistics of expected external and internal disturbances, the statistics of expected operating environments, the statistics of expected load reactions, etc. Furthermore, there are conditions of lightness, compactness, low power input, and operating under difficult temperature, pressure, vibration and shock conditions. Combinations of continuous and discrete computation now appear to offer the best solution to many of the design problems.

Information Processors for Testing & Operational Checkout - In the development of increasingly automatic aircraft it is natural to use automatic information processors in the laboratory test, flight test and operational checkout.

Again the problem is that of the automatic processing of important measured variables. The interest centers on the statistics of the variables and the statistics of the external and internal disturbances which corrupt these signals.

In the testing phase of the engineering development of an aircraft system the many adjustable parameters must be set at their most appropriate

values for operation over the probable range of environments to be met in the operational phase. Also the hoped-for behavior of the system must be checked over the partially simulated range of operational environments. The proper conduct of this test phase requires the maximum use of automatic measurers, communicators, and information processors. The well-engineered design of this information system involves consideration of information source rates, transmission rates, storage access rates and capacity, resolution and accuracy of information from source to sink, separation of disturbances, such as instrumentation errors, from signals and system reliability.

Again, as with the operational information processors, the present theory and practice combines continuous and discrete computing systems in matching the information processor to its task. The speed, lightness and compactness of analog subsystems are interwoven with the precision, flexibility and reliability of discrete or digital subsystems to form an efficient system.

Conclusion - A perspective view of the field as a whole shows an evolutionary or revolutionary change from the stage of information processing by men, slide rules and desk computers toward the nearly fully automatic information processing of the business, engineering, production, distribution, storing and operation of increasingly automatic aircraft systems.

CHAIRMAN McCANN: Thank you, John. Now your experts have had an opportunity to talk about the things they want to discuss, to emphasize those phases of the field which to them seem most important. The next portion of the meeting will provide an opportunity for you to make them talk about the things you want them to cover, to compare different types of computing techniques or whatever you wish in the way of a critical evaluation of the development and application of "information processing devices." We have, however, now spent about an hour and fifteen minutes here and we will next have a short intermission of about ten minutes before we start the second phase of this session.

RECONVENING OF SESSION

CHAIRMAN McCANN: Our panel has received from the floor a large number of questions. These have been sorted with reference to the panel member to which they should first be directed. I will start with Dr. Ridenour. Several have been directed to his attention.

This first question is from R. R. Bennett, Hughes Aircraft. He asks "By what year do you expect that a digital computer capable of handling large real time flight problems will be available?"

DR. RIDENOUR: I am glad that he asked that question, because it enables me to cover again in a few words of my own a point that Mr. Steele made which I think is worth noticing. That is that in the past history of computer development and use the emphasis in the field of analog computers has been more on special purpose equipment, equipment designed for a particular class of problems. Total differential equations, for example, are best suited to solution by the early differential analyzers and so on down the line, while the digital machines have from the outset been called general

purpose machines. This has not always been exactly the precise description of some of the machines, but what is meant by that is simply that the logical organization of the machine is intended to be comprehensive in terms of the machine's ability under some program or other to handle any class of problem. Now in order to simplify the construction of digital machines and to do such things as speed up their operation as you wanted to for simulation purposes, what you have to do is to think in terms of special purpose digital machines; machines whose organization and balance of internal operating times and all that sort of thing are especially contrived to fit them best to a particular class of problem rather than to endow them with some embodiment of what somebody vaguely supposes to be the general operating requirements for a very much wider class of problem.

Thus if you are interested in making a digital simulator I think that you would have to go more deeply into the requirements of simulation than I believe anybody has yet done. I remarked to Dr. Vance a moment ago that I suspected with about the same amount of money it is going to cost to build the contraption with 900 amplifiers in it you could indeed speed up the kind of digital computation required for simulation by a couple of orders of magnitude. So my answer to this question, "By what year do you expect a digital computer capable of handling large real time flight problems will be available?" is just exactly this; Roughly two to three years after someone seriously tackles the problem. To my knowledge except for this investigation going on at Pennsylvania, which is pretty much an investigation and not a determined high budget effort to knock the problem in the head, there is nothing going on.

CHAIRMAN McCANN: Floyd, do you have anything to add to that discussion? Do you want to make a guess as to the time element involved?

MR. STEELE: Well, I think it will be a few years before there will be a digital flight simulator. As far as the general simulation field is concerned, I think there are three kinds of ways that people are going about it or might go about it. If a person attempts to do the simulation entirely by some digital machine, what he usually does is make a series of approximating equations and collects the terms all together, and the effect of collecting these terms all together among other things, provides the general design criteria for the computer. A somewhat different approach to this might be to isolate sections in a computer each one devoted to a particular piece of the simulation. For example, bringing in the autopilot. You might devote an isolated section of a digital computer to imitating an autopilot, and the person specialized in that component would put in whatever non-linear terms, whatever pseudo histories or terms he wanted, and the flexibility of that section would be such that it would be immediately evident what changes in a particular parameter were doing to the whole system. The parameters wouldn't be lost by a general collection of complete system equations. Now where the system is entirely contained in a computer, including the instruments, the simulation of instruments and the simulation of the airplane is not what is required in actual testing of components. This other problem is the midway problem. A person designing a missile from scratch does not have instruments or an auto-pilot or any particular piece of hardware to put into the thing to try. He has to start out making a guess as to how everything will behave, and as it is designed he can see what

happens. He could start the total simulation in about a year's time by putting together things like 150 to 300 integrators, and then of course he would have to gradually speed the thing up as the hardware was available.

Since the demand of the simulator is not for new designs but for designs that have been going for a long time, I think that this is not too pertinent a problem.

CHAIRMAN McCANN: Here is a card which states: "The J. B. Rea Company is now working on a real time flight computer to be finished in 1953". That answers your question specifically. Does anyone else among the panel wish to discuss this question?

DR. VANCE: I would like to make a few remarks along that line. Naturally according to my past history I wouldn't agree to any schedule of less than ten years. In these discussions it is always a question of generalities. It is a very dangerous thing to be general about one of these things. We talk about big computers and small computers. The question is, how big is big and how small is small. If you take a computer represented by the capacity of this new device we are building for the Air Force wherein we have 200 or more multipliers, each of these multipliers is capable in itself of being faster than any single digital computer now in existence or planned, so you have over a 200 to 1 duplication. That means that something will have to be done at least about the processes of your multiplication. In other words, there is no way of simplifying multiplication. Multiplication is multiplication. I am sure that the people who have been trying to design the logic of digital parallel adders and things of that kind in the binary system would like to know how to gain in the scale factors of time. When you talk about a system of that size the only conceivable answer is, you go to microwave techniques wherein the time of flight around the wires would be important.

Now I believe there are two fairly serious programs underway to attempt to build digital and log devices so to speak. I wouldn't depreciate this program at the University of Pennsylvania at all because some of the people on that have had considerable background in solving the non-linear differential equations that represent flight systems. I believe that is a step in the right direction, but I still stick to my idea of ten years before you can duplicate the performance of one of these very large machines. I would like anybody from the Bureau of Standards to correct me if this isn't true, as there is a study underway at the Bureau of Standards to determine how to design an effective digital simulator. Does anybody in the Bureau of Standards care to say anything about that, possibly Dr. Spanstead?

DR. SPANSTEAD: All I can say is that we have the matter under advisement and are following through on a few ideas we have. We are hopeful we will come up with something.

CHAIRMAN McCANN: I have here another question which is somewhat similar, at least closely related, to the last one. We have just talked about this problem of digital simulation in real time, the question of relative speed. We have talked about it primarily from the point of view of simulation, let us say, for testing on a 1 to 1 or real time basis. I have a

question here that is somewhat related with respect to possible speed advantages of analog computing from a general design analysis point of view, where some other factors come into play regarding this timing factor. This question is from Professor C. H. Wilts of Cal Tech. He states: "The only practical engineering design problem discussed is the auto-pilot problem. Do any digital computer designers feel that applications to more complex design problems (e.g. aircraft flutter) can be practically accomplished at this time, particularly in view of the desire to study changes in performance due to variations of the many parameters of the system?" Let me address this to John Barnes.

DR. BARNES: Not being a flutter expert I think I will reflect it to a friend of mine, Dr. Ed Van Fees sitting in the front row. Don't you want to say a word about what the flutter equations are?

DR. VAN FEES: I don't believe I have any comments.

DR. BARNES: I will pass it back to the Moderator.

DR. VANCE: The Moderator himself is an expert in the field.

CHAIRMAN McCANN: Dr. Wilts is thinking of the distinct advantage that a direct analog provides in the field of design analysis where one is trying to study the effect of a varying large number of parameters and determining an optimum design taking into account a large number of controlling factors. It appears at present that the use of digital techniques requires that you state the problem completely, starting out with one set of assumptions, obtaining the results from that set of assumptions, which means a complete programming of the problem, the examination of results and then deciding what the next step will be in the analysis. At present it appears to Dr. Wilts and other people at Cal Tech that the set up of a direct analog or model with which you can experiment, provides a much more rapid and satisfactory method of analysis. You set up the general system not specifying exactly what all the parameters are--knowing only that the general physical system is described by a certain number of specified equations. Then with this general model you delineate areas of interest experimentally and narrow the problem down to more exact calculations in specific regions of greatest interest. I do not know whether this technique is being used on any digital computers.

DR. RIDENOUR: I want to make a general platitudinous type of remark which is that it seems to me this question and our Moderator's answer to it reflects once more in very clear fashion the poverty of input and output equipment that has been used with digital machines. That is, to my knowledge, there are only one or two people in the country who have made arrangements for intervention in the program that is being followed by a digital machine--the kind of intervention that would enable you in one of these design studies to alter a parameter in the course of a computation in order to find out where some characteristic or other has its best value. Similarly I know of only one place in the country where anybody has ever put an analog sort of cathode ray tube display on the output of a digital computer so you can look at it and see what it is doing, and not until you do that kind of thing will these devices--even though they are slow and poverty stricken as Arthur thinks they are--not until you do that, do they even have

a prayer of tackling such a problem. The people who have been using digital computers have been so beglamoured by their performance on mathematical problems, which is indeed dandy (laughter), that they have neglected to notice that provided with these amenities a digital machine might be a useful tool for some other thing such as the ones we are talking about here.

CHAIRMAN McCANN: Does anybody else want to comment further on this question?

DR. GROSH of the GENERAL ELECTRIC COMPANY, speaking from the floor:

What is reflected here is not that there is a poverty in input and output equipment that has been used with digital machines. If some of the engineers had had the gumption to put it into numerical analysis as the astronomers did 150 years ago, we wouldn't be trying to put 900 integrators on the end of one piece of wire. (Laughter and applause.)

CHAIRMAN McCANN: Let's direct this next question to Arthur Vance first. Mr. Milton Drandell of the Hughes Aircraft Company asks this question: "Can analog computers be adapted to solving problems in the business world, such as problems in accounting and more specifically in problems of production control? Are there any developments along this line?"

DR. VANCE: I would say right now I had never heard of anybody wanting to apply an analog computer to bookkeeping, (laughter) but when you get around to the situation of production control it is common and has been used for years in such places as bottle inspection machines and tin plate inspection machines. As a matter of fact you talk about the automatic factory. The only part of it that exists today is the analog part which has been growing continuously for the last twenty years.

CHAIRMAN McCANN: Floyd do you wish to add to this?

MR. STEELE: There is quite a little bit of what might be called analytical analog engineering that can be applied; the learning curve theory for example, is beginning in the planning of production processes. Probably a small analog machine would facilitate a good deal of the plant loading; in other words to load an aircraft plant you essentially take a learning curve which tells you how many people per unit you are going to require, and then you have to somehow figure out how many people you can actually put to work, incorporate a lag of some kind, and from this you get the proper distribution in people per week. Quite a good deal of work goes with this, and there isn't a chance to try it more than two or three work loads before one is picked out.

This is a hiring program and it is broken down and turned over to personnel, and they start bringing people into the plant. Again in breaking down a master schedule which this machine would produce, to detail schedules, a lot of this--though it is presented in a tabular form--is very easily usable with analog work and detailed scheduling could also be done.

CHAIRMAN McCANN: This question deals specifically with regard to applications in the business world. I do happen to know of some work in the field of economics in which considerable success has been obtained in the solution of certain of the linear equations of business economics by analog

techniques. In fact one of the groups working on this has built themselves a special purpose computer for this use.

Here is another question I want to direct first to Arthur Vance. It is from Walter F. Bauer of the University of Michigan: "What are the relative merits of the two types of computers in dealing with problems involving extensive function generation, especially empirical functions of more than one variable as found in aircraft simulation?"

DR. VANCE: As far as functions of one variable are concerned, the situation is quite clear. That constitutes one of the major weaknesses of the present general purpose digital computer. We had the problem of as many as twenty or forty non-linear arbitrary functions. In some cases you can memorize all these functions. In terms of high-speed memory, that is a terrific problem. There is not a computer on the boards that would come near doing that. One possible solution which is amenable to this kind of work would be developing power series and extrapolation methods to compute these functions. Even if you are fortunate enough to gain much by that technique, you are still using up arithmetical element time. The generation of functions of more than one variable is a very difficult task for both types of machine.

I think it would be just increasingly difficult for the digital machine for the same reasons I have stated. Now for the analog machine there isn't any equipment so far available for that purpose. It is normally handled by attempting to approximate these functions as sums or differences or products of one variable. There are several methods that have been proposed, and there is no reason why they couldn't be made to work. The function generators would be a function of two variables.

CHAIRMAN McCANN: Here is a question from C. B. Poland of the General Electric Company, Hanford Works, addressed to Mr. Steele: "What is your opinion regarding the major obstacles to cost reduction in producing digital computers?"

MR. STEELE: Well, major obstacles are the number of components. Often the components are not always being used at unusually high speeds or somewhat out of their normal ranges. I think the whole problem in this is to attempt to reduce the complexity of the machine and reduce the number of parts, and this automatically will reduce the production costs and should bring it way below the analog. The reason the digital has the potential of being very cheap is because the complexity of it can be controlled. You have a machine that is basically extremely simple. As a matter of fact except for things like the player piano there has never been a mechanism available in which people can get many units of complexity response out of one unit of equipment. Of course that is the reason the analog will not ultimately grow to great complexity and requires at least one unit of equipment for one unit of the complexity of response. In the digital if everything is in a normal easy memory you would have the equipment in one memory channel of 4,000 relays since each piece of information on the channel can be altered or taken out or used in some way in a sixtieth of a second. You have something very much like a relay. The 4,000 relays cost you about the same as it costs to make six or eight relays as far as elec-

tronic equipment is concerned. Let's look at the relay. The reason that you can't then make a machine that is 4,000 times as complex as the present one with the same equipment or cut the complexity a few thousand times with existing machines is for the reason that nobody really knows how to use the memory. There are ways of using it that make it simple, and there will be many more ways developed later. I think the direct answer to the question of the cost of producing machines is almost entirely that of extreme complexity of components because that complexity in turn also demands unusually expensive components and unusually precise components. You reduce the number of components and reduce the cost of components also.

CHAIRMAN McCANN: Does anyone else on the panel wish to comment on this question? Here is one directed to John Barnes from Mr. R. E. Carr of the Jet Propulsion Laboratory: "Do you know of any practical (i.e. operating) device which can be used in connection with electronic analog equipment in order to simulate $f(t-\tau)$ from an input of $f(t)$? I assume here that τ is an assigned positive finite constant, but otherwise is unrestricted. That is, it would be desirable that τ could be assigned either large or small values. I realize that reading on to magnetic tape and off τ seconds later is theoretically a possibility. Is it an actuality?"

DR. BARNES: Well, I don't know of any you can buy, but I don't think it is too difficult a problem. Long ago at M.I.T. Gray and Brown developed an analog type of computing machine in which they used this process. They used film. Mr. Carr himself suggests magnetic tape. I think that this is quite feasible and a modern way of doing it.

CHAIRMAN McCANN: This question is directed to Arthur Vance from Walter F. Whitbeck, Bonneville Power Administration: "In the large simulators it is proposed to set elements against a standard, or to check components in the same way. If this is done manually, it will be very time-consuming. Have any automatic or semi-automatic methods been proposed for this task?"

MR. VANCE: I believe I mentioned the clutch servo type of mechanism which Convair is using where you set a large number of potentiometers. That is planned for the Air Force. It is not intended that in any short length of time all the components could be checked against the master standard, but they would be tested at some routine interval which would be determined by the stability of the elements.

We hope this interval will be at least a month and possibly longer so that one eliminates the routine of taking the impedances, unplugging them from the machine, plugging them in a standard bridge, and continually adjusting them. Calibration is practically mandatory if you have precisions beyond a part of 10,000. It has been our experience that many elements will hold indefinitely to a part in 1,000.

CHAIRMAN McCANN: Here is one directed to Mr. Steele. It is from R. R. Johnson of Cal Tech: "Boolean difference equations were mentioned by you as a potentially powerful tool for handling sequential problems in logical design. Would you be kind enough to amplify this statement indicating what you mean by this principle, and including a possible application of the technique."

MR. STEELE: I think those who use Boolean algebra every day use it in a form that Shannon put it in which he borrowed the signs and the processes from ordinary arithmetic, and with a few mental reservations the Boolean propositions can be treated very much as they would be in ordinary algebra or arithmetic. If we create these operations that Shannon defined with two of the total table of tautologies and the prime, that gives us three. There are many people who express the total table of tautologies by quite a number of combinations of these operations. We define another one, and for convenience call it subtraction. We get an exclusive core, you might call it, and it enables us to write a proposition at a given time. At this time then we can write a relationship between a number of variables. Then we can write the relationship T plus ΔT and subtract the 2 by logical notation and that gives us chains. This is only a beginning, or a kind of a marginal case. Actually the problem in logic is not that of expressing relationships among a number of things, but the sequence of them. The thing that makes a machine large is not one of static relationship, but a sequence long in time which has to be followed. I would like to say in passing, take the table of tautologies and apply the practical principle to it and take the first difference of the table, and you will find out that the table of tautology reduces from 16 to 2 as far as form is concerned. As a consequence the first difference of the tautology seems to be more important than the table itself. One might say that the tautologies and how they change gives you a means of progressing from one relationship to the next by an operation. That doesn't do too much justice to it.

CHAIRMAN McCANN: Here is one directed to John Barnes by Mr. M. Levy, Post Office Department, Canada: "I thought the problem of flutter of airplane wings was solved twenty years ago. I published myself, a solution using Lagrange's Equations. Probably the parameters have increased since then."

CHAIRMAN McCANN: Do you want to make any comment on that John?

DR. BARNES: I still say I am not an expert on flutter.

CHAIRMAN McCANN: Mr. Levy has, I believe, answered this question himself. The number of parameters the aircraft engineer must consider today in making a design from the flutter point of view has increased considerably from that used ten years ago.

Here are two questions that are very similar. One is asked by R. G. Canning of U.C.L.A. and the other is asked by R. B. Conn of the Cal Tech Jet Propulsion Laboratory. They are directed to Floyd Steele: "Will you please give an unclassified example of computing and/or control without numbers." "What is this non-numerical data representation you mentioned? Give a 'for instance'."

MR. STEELE: A rather easy process for the non-numerical to carry out is non-convolution. We are trying to decide what to do with a convoluter, we call it, and what you do if you have sets of twenty or thirty convoluters. There is no history or background on how it is to be utilized. To give a simple example on a non-sophisticated type of non-numerical computation, suppose we picked data off a single time varying instrument in the form of a plus 1, whenever the instrument goes up, and a minus 1 whenever the instrument goes down. Normally we need two channels to convey such kind of work, because the instrument also stands still. We apply clocking intervals to this. It is very fundamental. You are going to clock the instrument

every time and it can do one of three things. It can go up one, down one, or do nothing. If you wish to convey the fact that it does nothing you alternate between minus 1 and plus 1. Now supposing that you are involved with a difference equation of some kind that has come from translating the differential equation that has assumed there is a linear friction term in it. If you pass data back through memory this type of one minus one data is automatically passed, and you allow the delta T equal to K, and then recombine the data again beginning with the present through a non-numerical subtractor, you substantially form a multiplication. You have taken the derivative and multiplied by the constant. It requires less equipment than the analog technique, and it is an extension of this. This is a very unsophisticated method, of course, because you are tapping the memory. A more sophisticated way is to tap the memory continuously by another memory in such a way that you perform not just simply the first difference multiplied by a constant, but you perform a general convolution and you solve the linear system. I hope that answers the question.

CHAIRMAN McCANN: Mr. J. F. Kalbach of the William Miller Corporation, Pasadena, asks this question of Dr. Ridenour: "What are your feelings on the accuracy justifiable in computers when an overall accuracy of five or ten per cent is often all that is desired when considering the validity of assumptions? You mentioned 0.1% or a decade better is desired in analog computers. Some people would be happy to know where to put the decimal point."

DR. RIDENOUR: I didn't mean to suggest that you had to build a better computer than is required by the necessities of your problem. What I meant by the numbers I gave regarding the precision of analog machines, is that this is--by golly--the end of the line. This is as far as you can go in using such techniques, and therefore there is a boundary to the kind of problem that you can handle using these techniques simply because there are certain instances in which you desire more precise answers than one part in 10^n will give where "n" is five or smaller. I don't know whether this is an adequate response to the question, but it is all that occurs to me.

CHAIRMAN McCANN: We are running late on time. We have several more questions. Here is one for Arthur Vance from W. L. Martin of the Telecomputing Corporation: "How does the use of back-to-back phototubes eliminate the problem of drift and allow for a suitable stabilizing chopper? Does not differential drift still exist in the phototubes?"

DR. VANCE: Yes, it does. This is not a driftless affair. The two photo-cells have to be alike and have the same amount of light. Change in resistance must be on each photo-cell or an amount commensurate to the sensitivity of the cell. We have found it is possible to balance these things so they hold up for periods of days. There are, of course, mechanical choppers. You don't need anything like that at least.

CHAIRMAN McCANN: Here is an unsigned question directed to Mr. Steele. "For same accuracy, approximately how much slower is digital simulation than analog simulation?"

MR. STEELE: I think the answer for average practice today is about half an order to one order. Digital simulation, for example, would

do very well on all the translational problems of an aircraft and simulate the rotation problems on large wing-craft without too much difficulty. As far as the same accuracy is concerned, there are a lot of things that aren't explored yet, the chief thing being that there are these digital processes in which you can trade time and accuracy the same as on an analog. There is one difference, and that is being exactly repeatable and can be calibrated. There is no effort that I know of that has been made in this direction. Presumably a person could cut the accuracy down quite a way and make studies in the nature of the errors and do an error computation for a fix-up or somehow juggle the thing so the error is compensated. That technique hasn't been used. I think the answer is on the order I gave on the wing-craft. If you get into roll rates of the rockets or translational rates of some rockets, the digital is about one order off.

CHAIRMAN McCANN: Next is a question from Richard P. Gaunt, Cal Tech Jet Propulsion Laboratory, and it is directed to Mr. Vance: "Our most serious component deficiencies are in relays and polystyrene capacitors. Are these yours? What types of each are you using?"

DR. VANCE: As far as the polystyrene condensers are concerned, the last large computer we manufactured was the Typhoon Computer. The condensers were \$1.60 each on the surplus market and were made by the Western Electric Company. We found that under controlled conditions they can be calibrated and held to the known value better than a part in 10,000 for a period of months. Similar data on polyethylene shows tolerances on the order of one part in 10,000. I am sure that condensers of equal excellence can be purchased today.

Now as far as the relays are concerned, I don't know what he is talking about. In the original Typhoon we used a very high-speed computing relay. Now those relays, because of the fact that they have to operate in a hundred micro-seconds and do it very accurately they were very much of a design and manufacturing problem, but they are not as I understand it a serious deterrent in the operation of the Typhoon. The other relays you might use in analog computers of the type we build would be the relays used for putting in and out initial conditions and starting and stopping the machine and changing parameters and things, and I can see no relay difficulty there if ordinary precautions are taken.

CHAIRMAN McCANN: I presume he is speaking of relays used for this last purpose Dr. Vance mentioned. I might point out that with our computers at Cal Tech, we have the same problem where we have higher speeds to worry about as compared to an electronic integrating type of computer. We find the Western Electric Mercury relay is very satisfactory from every point of view including reliability; just to mention a specific relay that seems to fit this particular application.

Here is a question directed by Mr. V. P. Magnuson, Bendix Computer Division, to Floyd Steele: "What type of error correction can be applied to compensate for errors arising from random noise in the channels which transmit incremental changes only? Loss of an increment would seem to permanently place in error the number which should have received the increment."

MR. STEELE: I don't want to go into this too far. It is of a classified nature. I would say this in general. A chief problem in the use

of numbers for automatic control is that a number may be looked upon as an abstraction of the whole past history of the instrument inputs, and an abstraction of the whole past history is useful in some cases and poor in control. The past that you want in control dies out fairly fast, and even in cases where you are simply perturbing the parameters of the system a little bit to adjust for gradually changed flight conditions you don't want too much past history available. Numbers are not particularly useful for automatic control. The second thing, and that is the purport of the question; numbers themselves are very subject to disturbance by noise and random interchange from one to zero will blow up a number entirely. If you communicate between the numbers by counting systems the chance interchange from one to zero puts a permanent error in. The non-numerical techniques are not subject to this in particular and they behave like the analog. They keep a past history. The past history is not extensive and dies out rapidly through the use of weighting functions, you might say, and the result of this is that a casual interchange of the one and zero passing into the machine disturbs it the same as a random piece of noise on an analog will disturb it. It passes out of the system and doesn't lodge as permanent in the whole history of the control. I think perhaps that indicates the answer to this question.

CHAIRMAN McCANN: We now have just a few remaining questions. The next card is from W. W. Seifert of M.I.T. He doesn't ask a question. He would like to give some information. He says: "In response to Mr. Vance: The flight simulator group in the D.A.C.L. at M.I.T. has scheduled the installation of four generators for representing functions of two independent variables during June 1953. These will be on the order of 1/4% accuracy." I notice that somebody has written on in ink a question as to whether these are truly arbitrary functions. Bill Seifert, would you like to comment on that?

MR. W. W. SEIFERT: They are arbitrary in respect to the fact that you can't have double value functions or anything like that. They aren't necessarily monotonic or anything of that nature.

CHAIRMAN McCANN: Here is a question that comes back to the somewhat controversial one we cut short. This is submitted by Richard C. Booton of M.I.T. The question is directed to Dr. Barnes: "The implication was given that the use of computers reduces design procedure to an automatic process. Do you really feel that any original design concepts can arise from automatic computation, or that significant progress can be made in new areas unless machine computation is used as a tool by competent analysts."

DR. BARNES: I am glad to have a chance to answer this one. I don't think engineers will be out of jobs very soon or even analysts operating computer machines. I would like to make an example out of the filter theory. Back in the 1920's or 1918, in through there, people had just discovered that electromagnetic wave filters could be made by using transmission lines such as telephone transmission lines. The design of filters in that day was done by coupling end to end with recurrence relations, combinations of known types of filters and the size of known types with certain rules. Later on in the early twenties people looked at the problem in a normal filter of the type in which designing was a change in attenuation, frequently in the pass band. They designed networks that would offset this and equalize it. This was the beginning of equalizers. These were networks designed with an arbitrary or prescribed characteristic for telephone work. Later on Cauer and others proposed a more general problem of designing a filter with certain specified

types of elements to have prescribed characteristics with certain limitations for two terminal networks and later four terminal networks, including filters and so on. There is quite a bit of literature on this subject. When you have developed a good system of design that will design characteristics, it is quite possible to reduce this to an information processing device, a computer which will turn out your designs. It doesn't require this spark of originality that a lot of people think of when they think of designing an airplane, for example. This is only because the aircraft design field is still in the early stages relatively to electrowave volts, for example, so I think in this sense that we will have design computing equipment that will give us answers to prescribed characteristics once we have moved along far enough in the theory of what we would like to do, and then mechanize it. Computing machines provide solutions to certain problems. These in turn will help us build up intuition so later we can develop hand methods for solving non-linear problems.

CHAIRMAN McCANN: Here is one from J. S. Morrel of Bendix Radio: "A number produced by an analog computer in solving a stress problem, for example, is in fact a sample from a distribution representing all numbers this computer (or many nominally identical computers) would yield in repeated trials of this problem. Likewise the physical property it represents is usually associated with a distribution over many individual structures. It appears that matching these distributions is a major computer problem. Comment requested."

DR. BARNES: Well I agree that in physical systems such as the analog computer of continuous type, we don't deal with a specific exact answer, but with a possible distribution depending on a lot of features such as the temperature of the computer and the noise level and the various other parameters that come in. But since the answers we want are still in the accuracy range of the computer, we are not too disturbed by this. I would like to refer another question back to the questioner here. Did you ever work with rounded numbers? You will find this is a problem in arithmetic and a problem of digital computers. You will find just as much distribution theory in rounded numbers as there are on computers in the distributions functions that arise on the computation. You are always working with range such as the mean value and variance.

CHAIRMAN McCANN: We have one more question here. In fact this is a request in a sense to amplify something from the floor by John J. Burke of the Jet Propulsion Lab. It is directed to Mr. Steele. Also he seems to want to comment about it: "If time permits I would like to phrase a comment from the floor regarding the relationship of computers to animal control mechanisms." Is Mr. Burke here?

MR. JOHN J. BURKE: At first I thought I had a considerable pseudo philosophical difference with Mr. Steele. One comment he made, I think, was on counting systems. In dealing with computers in terms of biological systems we might learn a lot by comparing the two biological systems. After all the biologists have really been in the computing business since 1929 or something like that. We might learn from them. However it seems to me a little confusing to talk about non-numerical systems when they are really numerical. Another comment I had which I would like to bring out in more detail pertains

to attempts to compare a computer to an animal mechanism. This is something that irritates me a little. It used to be popular for writers to refer to computers as brains and things of this sort. Now we would like to compare them to animal mechanisms. My comment is that I don't think it is such a superb device. It is actually quite crude, and most all the measurements it makes and data it collects in terms of engineering practice is of low precision and low response.

MR. STEELE: Well, the animal systems, without going into this too far, do some things we would like very much to do, and that is that they are like the analog systems; they are fairly free from accumulative disturbances or noise. That has been a severe handicap with the digital computer. The thing can't stand internal noise at all, and the animal system can. Also again we have the problem of initial conditions which the animal systems don't have. When we stand up and take off a set of gyros we keep our eyes closed. We pass that in some kind of a fashion through a coordinate transformation and down the control system. It doesn't require any setting up of initial condition, and this is a very desirable thing if you know how to achieve it. Actually we recognize analog systems as being digital. There is no theory for tracing them out. The fact is that there are now some processes that are both digital and non-numerical and don't use binary numbers and don't use counting either; you might call it a sign of progress where you can get such things accomplished that are a good deal alike: addition and subtraction and differential control and anticipation and transformation. If you can get things like that you may also have something that is like the animal system. It might be very useful to trace out animal systems to see if they are really this way. The fact of the matter is that animal systems not only have complicated visual processes way beyond this but their sense of balance is not too different from the thing you are trying to do in an airplane. Now we want to gather more data in an airplane to balance it than just the data from a gyro. We gather data from the compass and altimeter and other instruments and combine them altogether. We would like to combine all coordinates and use them as a reference to control. This is exactly what people do all the time, and they don't fall down if they have a random popping of the synapse. (Laughter) They start off with the wrong conditions. This is something that we would like to do. I think there are some clues. That is all we can say at the present time--there are clues how it might be done and some directions we might go, and the fact the two are parallel is a thing of extraordinary interest and of philosophical value. It has not come about deliberately--that is, people haven't deliberately studied it.

DR. VANCE: Might I make a comment? It seems to me that our concern about the human being transmitting information around to the form of noise is being overemphasized. The human being is an animal, and why the preoccupation with the idea of the on and off pulses and that his processes are rather crude. I would say that the fact that you measure nerve action as on and off pulses is just a secondary factor in determining the mechanism.

CHAIRMAN McCANN: Gentlemen, we have probably subjected this group of experts to enough discussion and it is time we called a halt to this discussion period. We thank you all for being here. We certainly thank the panel for providing us with an extremely interesting discussion.

END OF SESSION

COMMERCIAL APPLICATIONS —
THE IMPLICATION OF CENSUS EXPERIENCE

James L. McPherson
Bureau of the Census

The Bureau of the Census began operating a Univac System in April 1951. We temporarily stopped operation at the end of December 1952. During this period our Univac was housed in the factory in Philadelphia where it was built by the Eckert-Mauchly Division of Remington Rand Inc. The first of this year (1953) our Univac was shipped to Washington. It is now being re-assembled and we hope to put it back in operation within the next two or three months.

As soon after our Univac was delivered as operating personnel was partially trained which was about June or July of 1951, we introduced a seven day per week, twenty-four hours per day schedule. This schedule was continued throughout our operation of Univac.

During this period the Univac performed a variety of what we call "small jobs". Most of these were on Census work but some of them were for the U. S. Air Force, the Army Map Service or the Atomic Energy Commission. We call these jobs "small" not because they were small in importance but because they were small in terms of the amount of Univac time they required as compared with the two "large" jobs our Univac performed during the period we operated it.

One of the two large jobs was the preparation of certain population statistics and the other was the preparation of certain housing-family statistics. Both were part of the 1950 Census of Population and Housing. Important characteristics of each of these large jobs were (1) they involved a very large amount of input (a total of about 20 million input items for both jobs combined) (2) relatively little processing of each input item was necessary (a fraction of a second was the time required typically for the Univac to dispose of an input item) and (3) a fairly large amount of output resulted—the output units were tabular presentations of population or family-housing statistics for a complex of geographic areas.

Commercial applications of large scale, integrated, high speed information processing equipment which come to mind most immediately are the activities under the jurisdiction of the accountants and bookkeepers. Whether these are more or less important than other possible commercial applications I am neither inclined, nor prepared, to argue. Control of all sorts of industrial processes will undoubtedly become more and more automatic through the use of these new electronic data processing devices. Such applications challenge the imagination and invite investigation and discussion. I feel competent only to conjecture and speculate about the impact of these equipments in this area.

The bookkeeping kinds of applications are, I believe, similar in many respects to the work we have done at the Bureau of the Census. Characteristics they share with Census applications are: (1) large numbers of input items (2) a small amount of processing per input item and (3) a significantly large amount of output. This is, of course, a generalization to which numerous exceptions can be found. However, it is, I think, obvious that maintaining inventory records on thousands of items, or preparing payrolls for thousands of employees, or sending monthly bills to thousands of customers or clients are applications much more akin to Census jobs than they are to the problems of engineering and applied mathematics to which large scale electronic computers have already contributed significantly and for which they were originally developed.

To our knowledge there exists nowhere, other than at the Census over eighteen months of continuous full time (around the clock, around the week) experience with high speed electronic information processing equipment on problems quite similar to those faced by the accountants in the business community. This does not qualify us as experts in such problems, ipso facto. In fact, the statement I can make with most conviction is that we have much to learn about how, most efficiently, to use our Univac. Nevertheless, we believe a few important comments are dictated by our experience.

The first of these is that large scale electronic information processing equipment can be more efficient for many commercial purposes than any other tool, or collection of tools, presently available. This statement is true, I believe, for devices which exist today, are commercially available and have a history of proven workability. Whether or not they can be used economically in any specific situation depends only on two things. One is the size of the job. At present the devices most readily available are very large scale and rather expensive. Obviously the job must be large enough to justify the investment in equipment. The other factor is the ability of the user to analyze and accurately define the final objectives of his present procedures; his willingness to arrive at those objectives by what may prove to be radically different procedures; and his willingness to familiarize himself with the logic of, and programming for, integrated information processing equipment.

With respect to the first of these two points I am confident that it will become decreasingly important. Equipments of reduced speeds and memory capacities but which are general purpose and well integrated are beginning to become available at costs significantly below those charged for their larger and more ambitious forerunners. This is one way equipment investment may be reduced. Another may well be through pooling of resources to defray the cost of equipment. This obviously may occur in several ways. A group of users might own an information processing system jointly; a trade association might acquire one to supply service to its members; an owner might sell excess time

on his system to other users; or independently owned facilities may sell information processing services. A wonderful attribute of these general purpose devices is the speed and ease with which they can be made to stop work on one problem and begin work on another. It takes literally only a minute or two to change. Last summer there was a period during which Census personnel were operating two Univacs at Remington Rand's plant in Philadelphia for three agencies. There were many actual instances where one minute a Univac would complete the numerical solution of a complicated formula for the Atomic Energy Commission and a minute later it would be tabulating Census statistics, and within a minute after it completed the Census work it would be engaged on a conversion of coordinates task for the Army Map Service.

This versatility means that to share an installation of electronic data processing equipment a group of potential users need not have common problems. Each potential user, however, must meet the second requirement I mentioned earlier. He must analyze and accurately define his end objectives and then develop procedures to achieve those objectives which take full advantage of the capacities of high speed data processing equipment. Not only Census experience supports this point. I have some familiarity with several investigations of the commercial applicability of these new equipments which were conducted by potential users. Two cases, in particular, I think bear mention. Both are multi-million dollar corporations with long histories of successful operation. Their businesses are quite different yet their investigation led to similar conclusions. These were that through radical changes in procedures significant economies could be effected through the use of these new equipments. In general these changes require the consolidation, into one integrated operation, of activities which are now being conducted in separate departments. In fact, in both cases most of the success of the investigation resulted from the fact that the investigators were staff officers attached to the very top officials in their respective companies and therefore were able to cross existing departmental lines with little or no difficulty.

To restate, briefly, the first point concerning commercial applicability - equipment in operation and commercially available can be used profitably by the business community today if users will apply their detailed knowledge of their problems to the development of procedures to exploit these equipments.

Please keep the foregoing in mind. A person who believes he has perfect facilities for performing any task is either a genius or a fool. We at Census know we are not the former and hope we are not the latter. We are not satisfied with the equipment we have. I will try to indicate some ways in which we think it could be better. Unfortunately there have been instances where our indications of shortcomings have been interpreted as general condemnation of these equipments. This is completely unjustified. We are only trying to indicate how good equipment can be made better.

The input-output facilities presently available are badly out of balance with the ability of these equipments to manipulate information internally. There are two reasons for this. The first is a historical reason. These equipments were originally developed for applications where large quantities of input and output did not exist. Only when the designers and builders looked for commercial application did these facilities become important. The second reason for the mismatch between input-output and internal processing speeds is an engineering one. The input-output devices must make the transition from the physical world we humans know and operate in where time is measured in months, days and hours to the electronic world of the data processor where time is measured in seconds, milliseconds, and microseconds. This transition can be accomplished only by equipment with mechanical as well as electronic properties. We do not believe that designers have developed the best mechanical components for these equipments yet.

On the input side particularly, however, we think it is hopeless to expect mechanical elements to operate at speeds comparable to the internal speeds of the information processing equipment. This being the case we believe we must look for means to minimize the inefficiencies that slow input causes.

Procedures we used in the 1950 Census of Population and Housing will illustrate this problem. A census enumerator recorded the required information on a schedule, later a census clerk converted some of the information from descriptive words into number codes, still later a key punch machine operator transferred the intelligence recorded on the schedule to a punched card, and later still a card-to-tape machine transferred the intelligence from the punched card to the magnetic tape which is the input medium for our Univac. Now let us look at rates of speed with which these processes were accomplished. The enumerator's job involved much more than recording answers on the schedule. Let us say that the 30 or so households for which he obtained information each day was reasonable and satisfactory. The coding clerk processed the information for about 300 households per day. The key punch operator prepared cards for about 250 households per day, the card-to-tape prepared tape for about 10,000 households per day. The Univac processed information at a rate of about 20,000 households per day (all of this is based on an eight hour day). Obviously, the more manual the process, the slower it is. An ideal solution for this Census problem would be a device which would read the information recorded by the enumerator and transmit it directly to the electronic information processor thereby eliminating the coding clerk, the key punch operator and the card-to-tape operation and even the magnetic tape.

It is unlikely that we will ever achieve this ideal. We believe we are making progress toward it, however.

The National Bureau of Standards has been helping us with this problem and has in the final stages of development a device designed to read a census

schedule and transfer the information thereon directly to magnetic tape. In order to use this equipment we must require our enumerators to record their answers by means of positioned marks rather than descriptive words or numbers but this does not, at present, appear to us to be particularly burdensome or undesirable. We hope through the use of this device to affect substantial savings of time and money by eliminating the key punch operation and the card-to-tape operation. (There may be a partially offsetting increase in the time and cost of coding).

This we think illustrates the most important way in which input can be brought more nearly in balance with the information processing ability of these devices, namely by more complete integration of the processes involved. Possible commercial applications are very easy to visualize. For example: (1) cash registers which communicate directly with magnetic recording media very likely will be developed before long (2) the charge-a-plates now used in most department stores may well be modified so they initiate a communication with an information storage reservoir (3) standardized type used to record serial numbers and amounts on bank checks can probably be read by equipment which exists today. Other illustrations are not hard to find. In fact some of you may be familiar with the perforated garment tags which are currently being used by some mail order houses and department stores to mechanize the process of input of information to inventory control systems.

The mismatch between output speeds and information processing ability may be more serious for some commercial applications than it is for Census work. For some commercial purposes - account billing for example - there may be a one-to-one ratio of input to output items. Here high speed, legible printing is extremely important. It would be untrue and unfair to suggest that this problem has not received the attention and interest of designers of these equipments.

In this area, too, the Census has sought the assistance of the National Bureau of Standards. It is, I believe, correct to say that so far we have been advised to save our money. In other words there has not yet appeared output equipment enough better than our Uniprinters which type ten characters per second, to justify the price quoted for the faster equipment.

In summary of the second point then: There is room and need for improvement in input-output equipment and on the input side particularly there is need for system development and integration.

In conclusion, I want to remind you of the history of the development of punched card equipment. We, at the Census, are proud to have fostered Dr. Hollerith who invented the punched card method to increase the efficiency of Census tabulations. We recognize that this method grew to be the powerful aid to business and industry it is today as a result of the interest in it and the demands made of it by private business. Electronic information processing equipment which exists today was developed to meet government needs. Private uses are just beginning to appear. As businessmen put this new equipment to work for their purposes they will learn where it is strongest and where it is weakest. Just as their father's influenced the course of development of punched card equipment, today's businessmen should direct the development of tomorrow's electronic data processing equipment.

PAYROLL ACCOUNTING WITH ELECOM 120 COMPUTER

Robert F. Shaw
Electronic Computer Division, Underwood Corporation

Introduction

The Elecom is a magnetic drum computer of the same general type as the Elecom 100, which was described in detail by Mr. Auerbach of this company at the meeting of the Association for Computing Machinery in Pittsburgh last May, and published in the Proceedings of that meeting. It differs from the 100 in two important respects; operation is decimal throughout, and the memory capacity has been increased from 512 to 1000 words. The change from binary to decimal operation results in a machine which is well adapted to commercial applications as well as purely mathematical computations.

Payroll accounting, because of the relatively small amount of input data involved, is an application which uses the 120 system with reasonably high efficiency. In the example I will describe, one computer, operating on a 7 hour a day, 5 day a week basis, can handle the payroll accounting for approximately 4000 employees.

Preparing the Entry Tape

The manual preparatory work includes collecting time cards, totaling for each employee the number of hours worked at regular and at overtime rates, and typing the employee number and the hour totals on a typewriter which simultaneously punches a paper tape. The result is the punched tape, together with a printed record like that shown in Fig. 1.

Here the first word of each pair gives the employee number, preceded by zeros to fill it out to the standard 8 digit length, and the second word shows the hours worked at regular rates and at overtime rates, with decimal point assumed to lie between the second and third digits in each case. The three digit number following the first entry of a group indicates the memory address into which that word is to be placed; subsequent words go into sequential addresses automatically.

As the payroll clerk processes the cards, she also arranges them in ascending numerical order by employee number. Since cards can ordinarily be collected from each rack in proper order, the amount of time involved in collating all cards processed by one clerk is relatively small, and this is one operation which can be done more efficiently by the clerk than by the computer. At the end of each ten entries a stop character is punched in the tape; this will later cause the computer to stop reading

Copyright 1953
Electronic Computer Division
Underwood Corporation

paper tape at this point and proceed with computation.

The Account Tape

Information concerning each employee is recorded on a magnetic tape. This data includes name, address, social security number, withholding exemptions, basic and overtime rates, and data concerning special deductions such as union dues, hospitalization and the like. In addition to these figures which do not ordinarily change from week to week, cumulative earnings and tax totals for quarter and year are recorded weekly, and at any given time the details of earnings and deductions for the previous or current week are included. A block of 50 words is assigned to each account. This space, equivalent to 400 digits, is considerably more than is logically necessary for the data stored, but two important advantages are gained. First, each item, regardless of how few digits it contains, can be assigned to a separate word, so that extraction and recombination are minimized, and editing is simplified. Furthermore, much of the data can be stored in edited form ready for printing; in fact, certain items can be recorded in both edited and unedited form. Results can thus be stored in only one section of the memory, from which they are both printed and recorded on tape, instead of being assembled in one place for printing and in another for recording.

Figure 2 shows a typical arrangement of data in the block. Column A indicates the word position in the block of 50. Column B indicates those items which are printed during weekly payroll processing. The items in Column C are used in the quarterly preparation of social security tax returns. Those in Column D are used in preparation of annual withholding tax statements. The only editing required in changing from one type of form to another is the appropriate shifting of printer stop symbols. Finally, Column E indicates items which are used in computation and are thus stored in unedited form. Note that many of these also appear in edited form. Thus it is unnecessary to "de-edit" an item carried over from one week to the next before using it in the new computation.

Starting the Processing

A weekly processing run is started by mounting the paper entry tape on the tape reader of the first input typewriter, and the employee account tape on the magnetic tape unit. The blank journal form is started on the first typewriter, and the combined statement and check form, together with the individual earnings record form, are mounted on the second typewriter. Fig. 3 shows the forms used. Note that the journal carries the same data arrangement as the order forms. It is therefore possible, by operating the typewriters simultaneously, to type only a single line of data for all three forms, so that typing, the slowest of all the operations involved, is kept to a minimum.

The only reason two typewriters are used is because the journal form is advanced a line at a time, while the other forms are advanced a considerably greater distance.

Manually operated dual paper feeds for typewriters are now available, and it is quite likely that an electrically operated version of this device

will soon be developed. When this can be obtained, all forms can be handled on a single typewriter.

The journal and statement-check forms are one-time forms, of course, but the earnings record form carries entries for thirteen weeks, with a heading showing the employee's name, address, and other pertinent information. Its registration with respect to the statement-check form is adjusted so that each week's data will fall one line below that of the preceding week.

In addition to mounting the tapes and forms, the date and the starting number for the pay checks are entered manually into the computer. Computation can now be started, and from this point on the operation is entirely automatic.

Computation

Fig. 4 shows a flow chart of the program. Ten entries are read from the paper tape, and one account from the magnetic tape. The employee number of the first entry is compared with that of the first account. If they differ, another block is read from the magnetic tape, and the process is continued until agreement is reached.

When employee numbers match, computation starts, and as it proceeds the magnetic tape is backed up one block. The latter operation proceeds in parallel with computation. Computation of earnings, deductions, and net pay is relatively simple and occupies less than 2 seconds. Editing of the results requires about 3 seconds more. Results are stored in the memory channel occupied by the block read from the account tape, replacing corresponding figures read from the tape. Thus cumulative totals are brought up to date, and the current week's figures replace those of the previous week. Appropriate portions of the data are then printed by the typewriters, and the block of data is recorded on the account tape, in the same block as that from which it was read but in a different channel. Thus the original block is not erased, and, in case of discrepancies, is available for reference. With five channels available in each block on the tape, data from as many as four preceding weeks can be retained before it finally becomes necessary to replace them.

In the course of computation, column totals are accumulated in the memory, and are printed out on the journal form at the end of the day's run. Any desired departmental or other group totals are also accumulated and printed as desired, and journal page totals may also be printed periodically.

Zero Suppression

Zero suppression is the most time-consuming operation in the editing process. It is made somewhat easier by making use of a so-called "normalizing" instruction included in the L20's code. This instruction, introduced originally to simplify programming of floating decimal operations, causes a number in the accumulator to be shifted to the left until its first digit is non-zero. The number of shifts required to accomplish this is automatically counted and recorded in a specified address in the memory. This number, in the present case, of course indicates how many spaces are to be substituted for the zeros preceding a number. The zero suppression

subroutine is a good example of the type of programming used in the 120. Figure 5 shows the zero suppression subroutine.

Column A shows the addresses in which instructions and data for the subroutine are placed. Column B contains the instructions themselves, each consisting of a space symbol in the sign position, not specifically shown; a two-digit number indicating the type of operation; and two three-digit addresses. Column C contains brief descriptions of the indicated operations.

Before entering the subroutine, the number N to be processed is placed in address 110 and in the accumulator and the subroutine is entered by means of the 26 instruction, which records in the right-hand address of the instruction in 106 the point of return to the main program, and then transfers control to address 100.

Instruction 100 causes the number N to be shifted and the number of zeros (p) to be counted and recorded in 109 as a single digit preceded by seven zeros and a positive sign. Instruction 101 subtracts this quantity from 8, and places the result in A after first clearing the shifted N, which has no significance. The result, s, shows how many significant figures N contains. Instruction 102 shifts this figure 6 places to the left, making it appear as the second digit of A, and then extracts it into that position in the instruction in 104. A word containing 9 spaces, including one in the sign position, is brought into A by the instruction 103. Now instruction 104 shifts these spaces "s" places to the left, making the "s" right-hand digits zero. The result, in A, is a word whose first "p" digits are spaces, and whose last "s" digits are zeros. 113 contains irrelevant data. It is now only necessary to add the original N to this number in A, store the result in 110, and return to the main program at the point previously recorded in instruction 106. The entire process requires 0.2 second.

Checking

Checking operations are performed as desired, and their scope is limited only by the amount of time one wishes to devote to them. Certain ones are worthy of mention and are almost essential.

For example, a common type of error is the introduction of an entry out of sequence. Since we have assumed entries arranged in increasing sequence, any one having a number lower than the preceding one indicates an error and can be detected with a simple comparison. It can then either be recorded on a separate line of the journal, or punched into an error tape (since paper tape can be punched from the computer.) It may also be advisable to list as an error any entry bearing a number appreciably higher than the preceding one; for example, if account number 1385 were inserted by accident between 1312 and 1313, the result, in the absence of such a test, would be to skip over all numbers between 1312 and 1385 on the magnetic tape and earnings records, and after computing on entry 1385, to list as errors all subsequent entries from the paper tape up to 1386.

Another obvious check is periodic cross-footing of column totals. Recording on the magnetic tape can be checked, if desired, by rereading the recorded block. If an error, such as the missing of a pulse, was made

during recording, automatic checks included in the reading operation will have a very high probability of detecting it. This latter check requires several additional seconds per block, and our experience with tape reliability would appear to indicate it is quite superfluous, particularly in view of the policy of retaining the previous week's record on the tape for reference.

Tax Returns

Since cumulative earnings totals have been kept from week to week in each account, it becomes a very simple matter to run off the quarterly report of social security taxes on form 941a. Practically no computation is involved; it is only necessary to accumulate the column totals. The only editing required is the insertion of a decimal point between dollars and cents in the quarterly earnings total, and placement of carriage return and printer stop symbols. Restoration of the quarterly cumulative totals to zero in each account is accomplished by a minor modification of the program for the next weekly run. Thus here again the most time-consuming part of the operation is the typing of the form.

Annual preparation of withholding statements on form W-2 is likewise a simple matter. Here again the only computation involved is the accumulation of column totals, and the only editing is insertion of decimal points and placement of printer control symbols. Again the clearing of annual cumulative totals in each account is accomplished on the next weekly run.

Operating Times

Operating times, on a per-account basis, are approximately as follows:

For weekly payroll processing, approximately 27 seconds, distributed as follows:

Reading paper tape	2 seconds
Magnetic tape operations	3.2 "
Computation, including editing	5 "
Typing, including additional line feeds on second typewriter	17 "

These times allow for the off-sequence checks mentioned above, and periodic cross-footings. They will be increased somewhat, of course, if more elaborate checks are desired, or if a large number of inactive accounts accumulate and have to be passed over on the magnetic tape and earnings records.

The quarterly social security report requires approximately seven and a half seconds per line, distributed as follows:

Magnetic tape operation	1.6 seconds
Computation & editing	1 "
Typing	5 "

Preparation of W-2 forms require about 21 seconds per form, with the following breakdown:

Magnetic tape operation	1.6 seconds
Computation & editing	2 "
Typing	17 "

Conclusion

Payroll accounting is, of course, only one example of the applications of the Elecom 120 system. In addition to the usual wide range of scientific and engineering computations for which high speed computing machines can be used, the 120 system can handle other types of commercial problems, such as cost accounting, inventory control, and insurance premium billing. Its chief limitation is in the slow printing speed and the slow speed with which paper tape is read.

Two approaches to the input problem are possible; a fast paper tape reader can be used, employing photoelectric pickup or other non-mechanical sensing means, or equipment can be designed for preparation of magnetic tape from a keyboard. Both of these methods are now under investigation to determine which is more economical, and it is expected that a decision can be reached and equipment made available within the next year.

The problem of designing a high speed printer which can be produced at a cost low enough to be commensurated with the rest of the system is considerably more difficult. We are confident that it will be solved in time, but meanwhile the problem of producing output data in visible form at a reasonable rate will continue to be the chief factor limiting this more extensive use of computers in commercial applications.

```
*00003127 200
*40000125
*00003128
*40000000
*00003129
*40000000
*00003131
*38750000
*00003132
*40000000
*00003133
*40000200
*00003136
*40000000
*00003137
*40000000
*00003138
*39500000
*00003139
*40000000 #
*00003140 200
*40000000
*00003141
*40000100
etc.
```

Stop character inserted here; does not appear in printed copy.

Fig. 1. Entry Tape

ACCOUNT TAPE
Arrangement of Data in Block

A			B	C	D	E
00	Employee Number	*00001234				x
01	Rate: basic	*00019529				x
02	Rate: overtime	*00029294				x
03	Exemptions	*00000003				x
04	Dues	*00000045				x
05	Hospitalization	*00000028				x
06	Earnings: quarter	*00091523				x
07	Earnings: year	*00381799				x
08	Withholding Tax: quarter	*00011832				x
09	Withholding Tax: year	*00054519				x
10	FICA: quarter	*00000320				x
11	FICA: year	*00005400				x
12	Employee Number	xxxxxx1234	x			
13	Regular hours	*4000xxxx	x			
14	Overtime hours	**250xxxx	x			
15	Gross Pay	*xxx**9654	x			
16	FICA	*xxxx****	x			
17	Withholding Tax	*xxx*1430	x			
18	Dues	*xxxx**45	x			
19	Hospitalization	*xxxx**28	x			
20	Earnings: year	*xx381799	x			
21	Withholding Tax: year	*xx*54519	x			
22	Net Pay	**8032***	x			
23	Date	*12-*7-53	x			
24	Check Number	*x54320tt	x			
25	Social Security Number	*999*99xx		x	x	
26	" " "	*9999txxx		x	x	
27-28	Name	xQUENTIN*	x	x	x	
29-30	"	xA*HASTIN	x	x	x	
31-32	"	xGSxxxxxx	x	x	x	
33-34	(Printer control)	xtxttxxxx	x	x	x #	
35-36	Address	x1854*E*7			x	
37-38	"	xSTcNEW*Y			x	
39-40	"	xORK*NYcx			x	
41-42	"	xxxxxxxxxx			x	
43-44	"	xxxxxxxxxx			x	
45-46	"	xxxxxxxxxx			x	
47-48	Amount	x**\$80.32	x			
49	(Printer control)	xcttxxxxx	x			

* Space x Blank (ignored by typewriter) c Carriage Return
t Tab # Modified during editing tt Printer Stop

Fig. 2.

EMPLOYEE'S EARNINGS RECORD

NAME Newcombe P. Riley S.S. ACCT. NO. 233-45-6601
 ADDRESS 333 Hartsdale Ave., City EXEMPTIONS 3
 DATE OF BIRTH 7/22/14 DIVISION Production

Check No.	Hours Worked		Gross Pay	DEDUCTIONS				TO-DATE TOTALS		Net Pay	Date	Check No.
	Reg	OT		FICA	M-H Tax	Other	Hours	Earnings	M-H Tax			

Check No.	Hours Worked		Gross Pay	DEDUCTIONS				TO-DATE TOTALS		Net Pay	Date	Check No.	PAY TO THE ORDER OF	Amount of Check
	Reg	OT		FICA	M-H Tax	Other	Hours	Earnings	M-H Tax					
1236	39	25	8792	132	970	45	28	37940	4490	7617	12- 7-53	54322	NEWCOMBE P RILEY	\$76.17

Fig. 3A. Statement of Earnings and Check Collated with Employee's Earning Record

EMPLOYEE'S EARNINGS RECORD

NAME Newcombe P. Riley
 ADDRESS 333 Hartsdale Ave., City
 DATE OF BIRTH 7/22/14

S.S. ACCT. NO. 233-45-6601
 EXEMPTIONS 3
 DIVISION Production

Check No.	Hours Worked		Gross Pay	DEDUCTIONS				TO-DATE TOTALS		Net Pay	Date	Check No.
	Reg	OT		FICA	W-H Tax	Deer	Hoop	Earnings	W-H Tax			
1236	4000	225	9716	146	1170	45	28	9716	1170	8327	11-16-53	38745
1236	3850		8624	130	970	45	28	18460	2140	7451	11-23-53	42235
1236	4000	550	10808	162	1380	45	28	29148	3520	9193	11-30-53	50672
1236	3925		8792	132	970	45	28	37460	4490	7617	12-7-53	54322

Fig. 3B. Employee's Earning Record

62

Check No.	Hours Worked		Gross Pay	DEDUCTIONS				TO-DATE TOTALS		Net Pay	Date	Check No.	PAY TO THE ORDER OF	Amount of Check
	Reg	OT		FICA	W-H Tax	Deer	Hoop	Earnings	W-H Tax					
1234	4000	250	9654		1430	45	28	381799	54519	8032	12-7-53	54320	QUENTIN A HASTINGS	\$80.32
1235	3950		7878	118	1320	45	28	130424	14472	6117	12-7-53	54321	THOMAS F KINGSLEY	\$61.17
1236	3925		8792	132	970	45	28	37940	4490	7617	12-7-53	54322	NEWCOMBE P RILEY	\$76.17

Fig. 3C. Payroll Journal

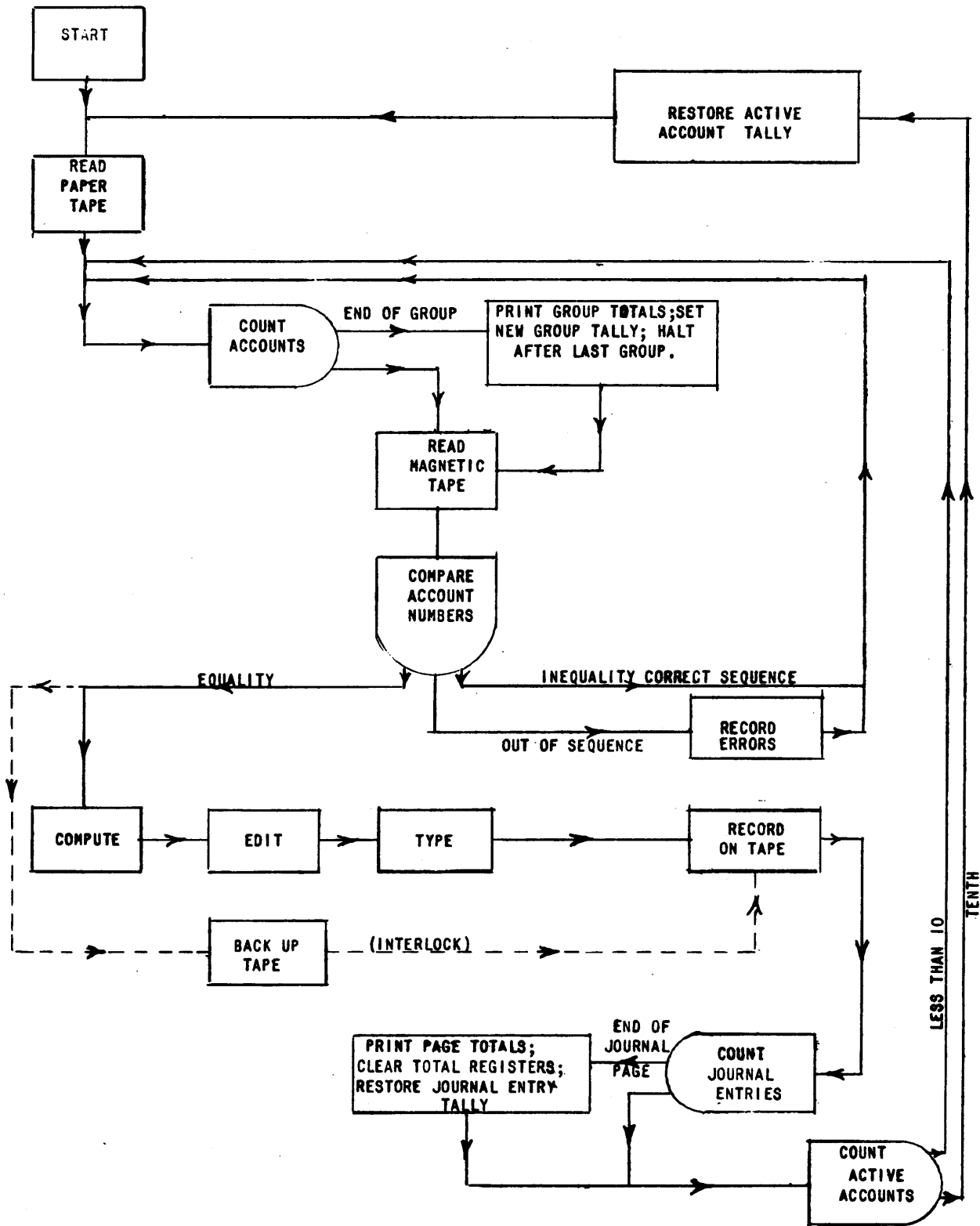

Fig. 4. Flow Chart of Payroll Processing with Elecom 120

ZERO SUPPRESSION SUBROUTINE

A	B	C
100	49 109 101	Find p; store in 109
101	16 107 109	8 - p = s into A
102	46 104 111	Generate space shift instruction
103	11 112 108	Spaces into A
104	4[s] (113) (111)	Replace s spaces at right with zeros
105	10 112 110	Add N
106	20 110 []	Store result; return to main program
107	00 000 008	Constant
108	** *** **	Spaces
109	[]	Number of zeros (p)
110	[]	N; later, corrected N
111	01 000 000	Extract control
112	00 000 000	Zero
113	[]	Working storage

Enter with instruction 26 106 100 after placing N in A and in 110. Result left in A and in 110.
 () indicates irrelevant information
 [] indicates quantities changed during computation
 N = number to be processed
 p = number of zeros preceding first significant digit of N
 A = accumulator

Fig. 5. Zero Suppression Subroutine

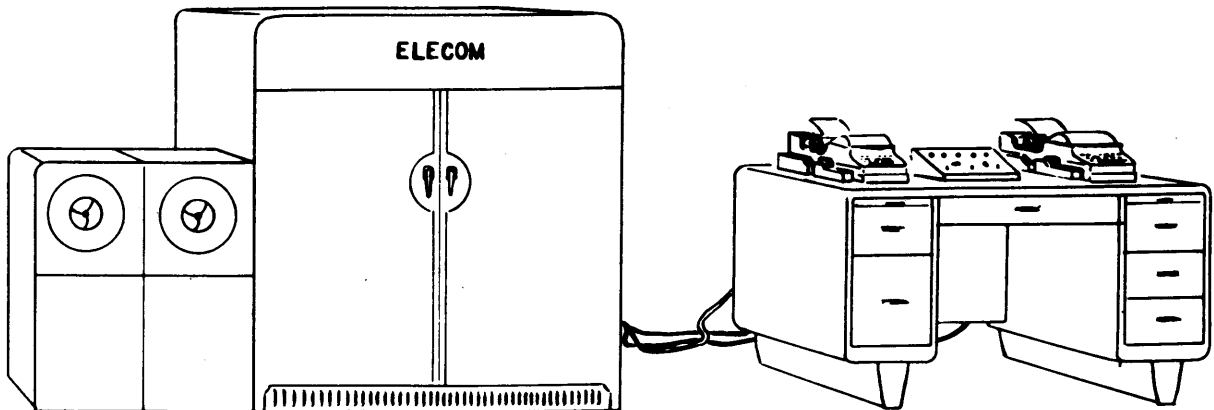

Fig. 6. The Elecom 120 System

"AUTOMATIC DATA PROCESSING
IN LARGER MANUFACTURING PLANTS"

by

M. E. Salveson and R. G. Canning^Δ
University of California, Los Angeles

If you have ever tried to drag a small child through a toy department, while trying to catch a train, you will have some feeling for the troubles of the Production Control Manager. He is faced with a never ending stream of unexpected troubles, all of which tend to keep him from making good his schedule. Development of ingenious methods to solve this problem has helped some, but in many cases, both the problem and ulcers remain.

The authors are engaged on a research project at the University of California, Los Angeles, on how to improve scheduling. The objectives are to provide quantitative methods as a basis for management decision, instead of the present predominantly intuitive methods. One main phase of the project is developing the "optimum schedule"--that schedule which makes the best use of plant facilities and materials. A conceptual "model" of a scheduling system has been developed by one of the authors and serves as a conceptual "framework" for this study.

But, in addition to methods for developing an optimum schedule, there is the further problem of meeting the schedule. This problem reaches its peak of bewilderment in the large job shop--where a large variety of products is possible, and production is to customer order rather than to inventory. Parts are made in small quantities, and there is a long time between repeat orders, hence, the learning process is minimized. Because tooling on one operation turns out to be unsatisfactory, the job has to be set aside until proper tools are obtained. Then the reworking of incorrectly made parts can throw off the schedule, and the rejecting of bad parts changes the quantity and necessitates rush orders. The machinist, not clearly understanding the print, decides to make the part his way--and sometimes this isn't the right way. Occasionally whole operations are skipped, by sending the parts to the wrong department. Or an order is lost; it is somewhere within the plant but no one knows where. Sometimes you can't determine the cause of the trouble; the part has been made satisfactorily 50 times before but this time it just can't be made right. And then just when everything seems to be going smoothly on the part, the customer changes his order--more earlier, fewer later, cancels out or other.

What is the result of all of this on the schedule and the man who is responsible for it? A sample survey was made in a local manufacturing plant. Table I shows what was happening to scheduling there. Out of 692 orders in the sample, only one was on schedule, all others either were early or

^Δ This paper was prepared while the writers were under contract to the Logistics Branch, Office of Naval Research.

late relative to the schedule. This same plant publishes a shortage list daily that is about 300 pages long. Decision-making is indeed difficult with that much data to consider.

Number of days <u>actual</u> differed from <u>scheduled</u> completion date	Number of parts completed within the interval	
	early	late
21 or more	128	114
17 to 20	84	78
13 to 16	72	48
9 to 12	40	56
5 to 8	21	28
1 to 4	16	6
"on schedule"		1

TABLE I

Figure 1 shows the variations in the work load in one department of this plant, a hydraulic press department. The solid line represents the jobs arriving in the department, and due in the future. The upper dotted line represents the past due jobs, and the lower dotted line is the number of jobs clearing the department on that day. Uneven flows and backlogs such as this mean loss of money to the firm, since parts often must be assembled out of the proper sequence; jobs, men, and machine are not available at the same time, etc. In part, this is just like putting the electrical wiring in a new house after the walls are up. This not only costs extra money, it also usually means that deliveries are "off schedule".

The variety of solutions to the production control problem is almost as great as the variety of problems. Probably the most common solution is some variation of the "manual" system. In this system, the problem is broken down into a number of small components, and different men are made responsible for these components. Expeditors are needed to coordinate efforts; it is not uncommon to find 2 percent to 5 percent or more of the employees of a plant working as expeditors. Under such a system, it is almost impossible to predict the load on a given production department even a few days into the future, especially where there is no standardized flow of parts through the plant.

To allow some means of predicting future loads, use has been made in recent years of punched card systems of production control. Punched card systems allow for more centralization. By sorting cards by expected dates and by departments, some estimate of future loads can be obtained. All predictions are based on standard running times, and the only way to enter the day-by-day variations into the cards is by mass key-punching new cards and replacing the obsolete ones. The common method of meeting this problem is to increase the standard running times until you can be sure the parts

will be made within the allotted time--and consequently, up goes inventory--raw, finished, and in process, and back into the future go delivery promises.

Electronic data handling systems offer much promise for helping solve such production control problems. Since, if properly designed, data in the system can be changed or erased at will, the system can keep up with the day-by-day variations. Actual running times can be remembered easily, for adjusting standards. Data can be sorted, collated, and transferred, to give different pictures of shop loads according to different needs. In short, an electronic system promises to provide what one of the Navy's top admirals recently asked for--a machine which, upon throwing a switch, would project onto his wall a "picture" of the major problems and bottlenecks confronting his organization at that moment.

To obtain a more concrete picture of requirements for an electronic production control system, our project has sponsored a detailed study at one of the local plants. The company has about 1000 employees, which is near the lower limit in size for companies who can consider an electronic system. They fabricate and assemble small but complex units on a job shop basis. The company at present has an efficient manual method of processing data; an idea of their efficiency is seen from the fact that only 7/10 of one percent of their employees are expeditors, as compared to a normal range of 1 percent to 5 percent. A total of 29 people are employed in production control, with such diverse jobs that only about half of them might be replaced by an electronic system. Amortizing this saving over $2\frac{1}{2}$ years, it is seen that the electronic system should cost in the neighborhood of \$175,000 to \$200,000. Some additional cost might be allowed if the system would provide very desirable scheduling data that are not now feasible. So let us say that \$225,000 to \$250,000 is the range we must shoot at. A company with such an efficient manual system was picked as a yard stick against which to compare the merits of an electronic system.

Time does not permit consideration of all the possible variations of an electronic system that were considered. For example, the idea of an all-electronic memory throughout was soon discarded, at least until more efficient systems are developed, as the volume of data was too great, and since other forms of memory were quite feasible. Also, not all production centers throughout the plant are tied to the machine by electrical communication circuits, since in general, information is not generated at a high enough rate to justify this.

In the next few minutes, I will hit the highlights of a proposed system that we believe can meet the requirements of this company. At the same time, I want to emphasize that this is not a general purpose system, but is designed for this one company specifically. For another company, many of the same building blocks might be used, but the parameters would be different. However, later in the talk, a design philosophy will be presented, based on our experience, which we believe will apply quite generally.

Figure 2 is a flow diagram of the procedure to be used in posting customer orders and the issuing of purchase requisitions, shop orders, and assembly orders. A typing operation appears unavoidable at the beginning, in order to prepare a standard sales order from the customer's order. Such

items as inspection procedure, renegotiation clause, customer code number, and product code must often be added to the information supplied by the customer. By using an electric typewriter that can punch a paper tape (such as the Flexowriter), data are in a form suitable for direct entry into an Electronic Data Handling Machine, designated here as the EDHM. This machine is quite similar to electronic digital computers of today; in fact, it is possible that commercially available machines will meet all requirements. Bills of material are prepunched into punched cards; the appropriate decks are selected by the operator and fed into the machine. Automatic access of Bill of Material data is not essential here in this plant, since only 40 to 50 assemblies are involved each day. The machine combines the variable information (quantities, due dates, etc.) with the standard data and posts these schedules on the Requirements magnetic tape. After all postings are made, the machine scans the requirements data for each part number, compares it with the inventory data from the adjacent magnetic tape, and pulls out those part numbers for which an order may be necessary. The operator scans these printed data and decides which parts to order and in what quantities and enters this information by a keyboard. The machine is then able to prepare the necessary papers.

More tape units, or the newer types of random access memory, probably would be desirable if the cost were not too great, to cut down access time. Allowing only 10 seconds to hunt each part number on the tape, the 1000 to 1200 individual part number entries per day will require about three hours machine time, which is almost at the maximum time limit allowable for this operation.

Figure 3 shows how shipment schedule cards can be prepared automatically, without the need for manual key punching. These cards contain the pertinent data of the customer orders, and can be sorted by delivery due date, by customer name, or other convenient breakdowns. The breakdown by delivery due date will be used in a later figure.

Figure 4 shows the assembly order procedure. Variable data such as quantity and due date is stored in the working magnetic memory; bill of material data, as before, are in pre-punched cards. The electronic machine in conjunction with a summary punch and interpreter combines the two, to provide individual requisition cards. The stock clerk, when filling the parts requisitions from stock, separates these cards into two piles--parts disbursed and parts that are short. Day-by-day changes are handled by a Summary Punch with keyboard in the stockroom, or a unit similar to the Talley Register, (made in Seattle). Disbursement cards are read by the machine and entered into the inventory tape previously shown. Shortage cards are read into the Parts Shortage magnetic tape.

Figure 5 shows the method of obtaining and recording shop progress data. As new shop orders are issued, they are recorded on a Shop Order Status magnetic tape. This tape is kept up to date by means of reading the completed move tickets (a pre-punched card), labor distribution cards (already being prepared by the Accounting Department), filled raw material requisitions, and inspection and reject punched cards. The machine is also able to prepare the next move ticket for each job, as the completed one is read in. The method of calculating the due date for this new move ticket will be discussed shortly.

Figure 6 shows the analysis procedure, for using all of the data gathered most effectively. The Production Controller selects shipment schedule cards (mentioned above) by due date: he is primarily interested in past due, due, and about due orders, and the cards have been sorted in this fashion. The machine reads these cards and collates with this information the data from the Parts Shortage tape. The data are graphically presented on a large visual Control Board, and show, for example, which customer orders are past due that have only one part missing. It is on such orders that the Production Controller concentrates his attention.

The machine is next asked to tell specifically which parts are missing on these assemblies, by part number. The Control Board might be adapted to this use by using a transparent plastic overlay on which are written the Bills of Material. Lights are lighted behind those parts which are missing.

The value of a temporary, graphical presentation should be emphasized so that the Production Controller does not have to scan a large number of figures. Details of the Control Board have not been completely worked out but the problems appear to be ones of cost and engineering, rather than new, unique problems. Several alternative approaches appear interesting, also.

Next, the Production Controller calls for the status of the shop orders which are making the missing parts. These data are obtained from the Shop Order Status magnetic tape. The overlay on the Control Board in this case gives the Route Sheets for these parts, and the lights indicate which operations the orders are in.

To get an idea of when these orders might be completed, considering the overall status of the shop, the Production Controller makes use of the Scheduling Machine. This electronic machine works on a principle very similar to the digital differential analyser. It is loaded from the Shop Order Status tape. Then with Route Sheet data at its disposal, it gradually works its way into the future. Whenever a machine tool becomes available, the machine scans the waiting shop orders and picks the one with the highest priority slated for that machine. By changing priorities, the Production Controller can "play" with the schedule, until he gets one that looks good for the next two weeks. Appropriate operation due dates and priorities are transferred to the Shop Order status memory, for preparing the next move tickets. The Production Controller then lets the machine run out for a month or two into the future to get a rough picture of what is ahead. It is estimated that the time scale is about three hours shop time per one minute machine time.

When the machine allocates a shop order to a machine, it causes a card to be punched, with all pertinent data. These cards can be sorted to give future department loads, possible tool conflicts, etc. After the machine has determined the schedule, the Production Controller or an assistant can play with it, testing out different priority rules, scheduling methods, etc. Monte Carlo methods can be used to simulate the conditions of machine breakdown, tooling trouble, inventory policies, and other day-by-day variations, to find a scheduling method that is least affected by these factors.

Also available from the Shop Order Status tape is a running total of shop order cost, as opposed to standard cost. This is a first order

approximation of how much the Production Controller can spend in expediting an order, and still make a profit. This is a value judgment, and often involves more than just the cost of the individual part.

Adding up the estimated costs of the above equipment, and including rental of punched card equipment for $2\frac{1}{2}$ years, gives an optimistic total of about \$264,000. Installation charges are not included. So while the electronic system probably costs in the right order of magnitude for this particular firm, it is not a foregone conclusion that it would be desired. However, this was a research study, and we were not trying to sell anything.

Experience at this one plant, plus the other surveys made by the authors, indicate a rather general purpose design philosophy for electronic production control systems. For the next three to seven years, it is likely that most such installations will make use of existing equipment and techniques (such as punched tape, punched cards, electric typewriters) as well as newer electronic devices such as random access memory. The system must be tailored to meet the individual plant's requirements, as we see little hope of a general purpose system. The human operator will still be the main source for important judgments; the machine can only help out on the routine choices (not of a complex nature). Therefore, a good integration of men and the machine must be engineered. Recent studies on information theory in psychology should be of great assistance here. Many results of the data processing for Production Control need only a visual display, and need not be permanently recorded; this will reduce very materially the printed output problem.

The Production Control Center in a plant thus takes on the aspect of a Combat Information Center aboard ship. The machine processes the data and presents it to the humans for decision-making purposes. The plant machine works on a different time scale than does the CIC--hours instead of minutes or seconds, so that the plant machine need not be designed to aid in the minute-by-minute decisions.

From an engineering standpoint, it is quite evident that data should be recorded in machine language as close to the source of data as possible, in order to reduce manual operation bottlenecks to a minimum. The use of existing equipment where possible has the advantage of predicting the level of reliability in advance. Also, this reliability and the accuracy of the system can be improved by providing routine cross checks between Accounting Department data and Production Control data. Finally, an all-electronic system is not necessarily desirable, and depends upon the economics of each specific case. For example, the inter-department mail system may be a completely satisfactory communications channel for some of the data. Similarly, not all data has to be stored in electronic, random access memory. In short, the system should be designed to fit the company, rather than squeezing the company to fit the system.

In this paper, we have presented some of the initial results of our Industrial Logistics Research Project. We are anxious to place these results before business management, as potential users of electronic data handling systems, as well as before electronic equipment manufacturers. It is hoped that we can perform some small service toward a meeting of the minds, between users and producers of this type of equipment. Time has not allowed a detailed

description of the topic of this paper, nor an indication of the other affiliated areas in which we are working. For any such additional information, we extend a cordial invitation to all interested parties to visit us at U.C.L.A.

REFERENCES

1. Salveson, Melvin E., "On a Quantitative Method in Production Planning and Scheduling", Econometrica, October, 1952.

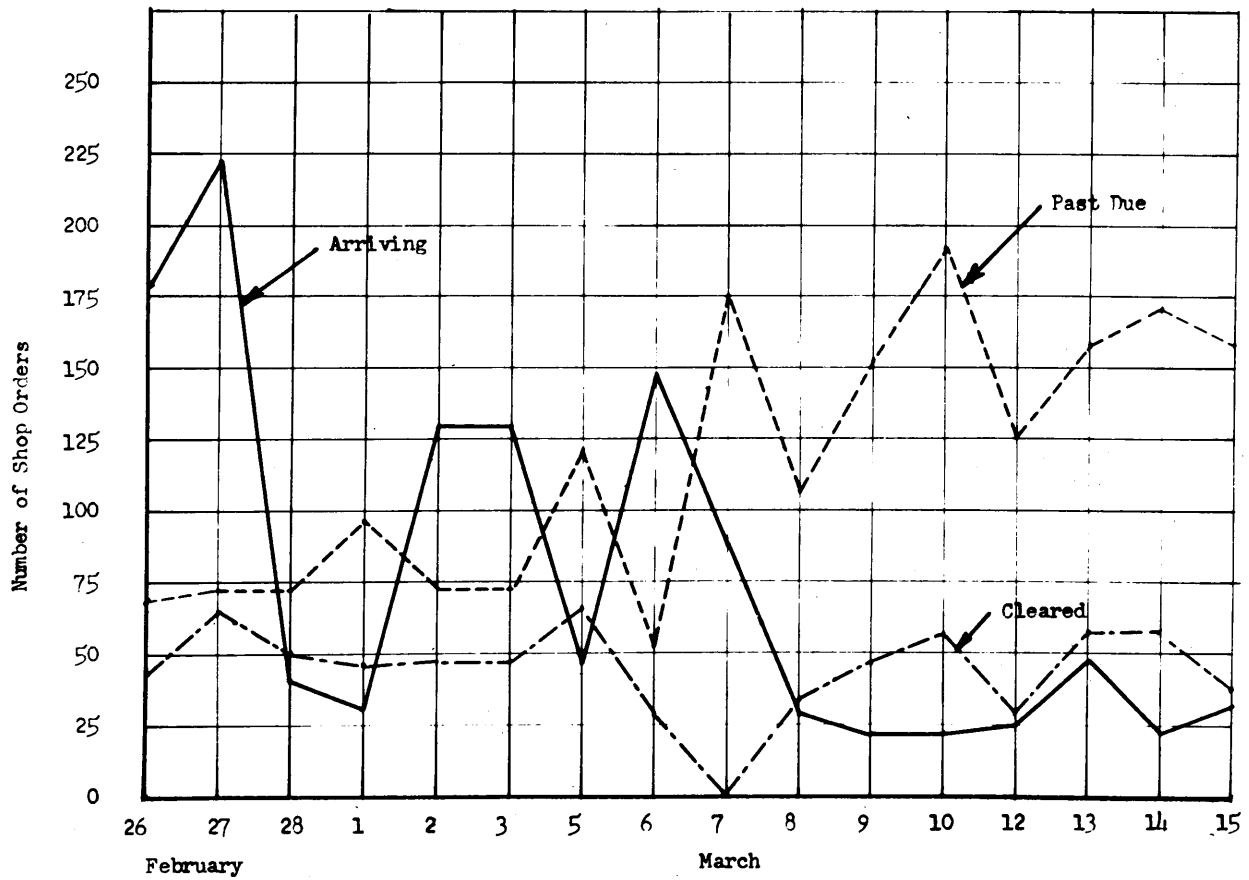

Fig. 1- Typical Variations in shop loads (Hydro Press Department).

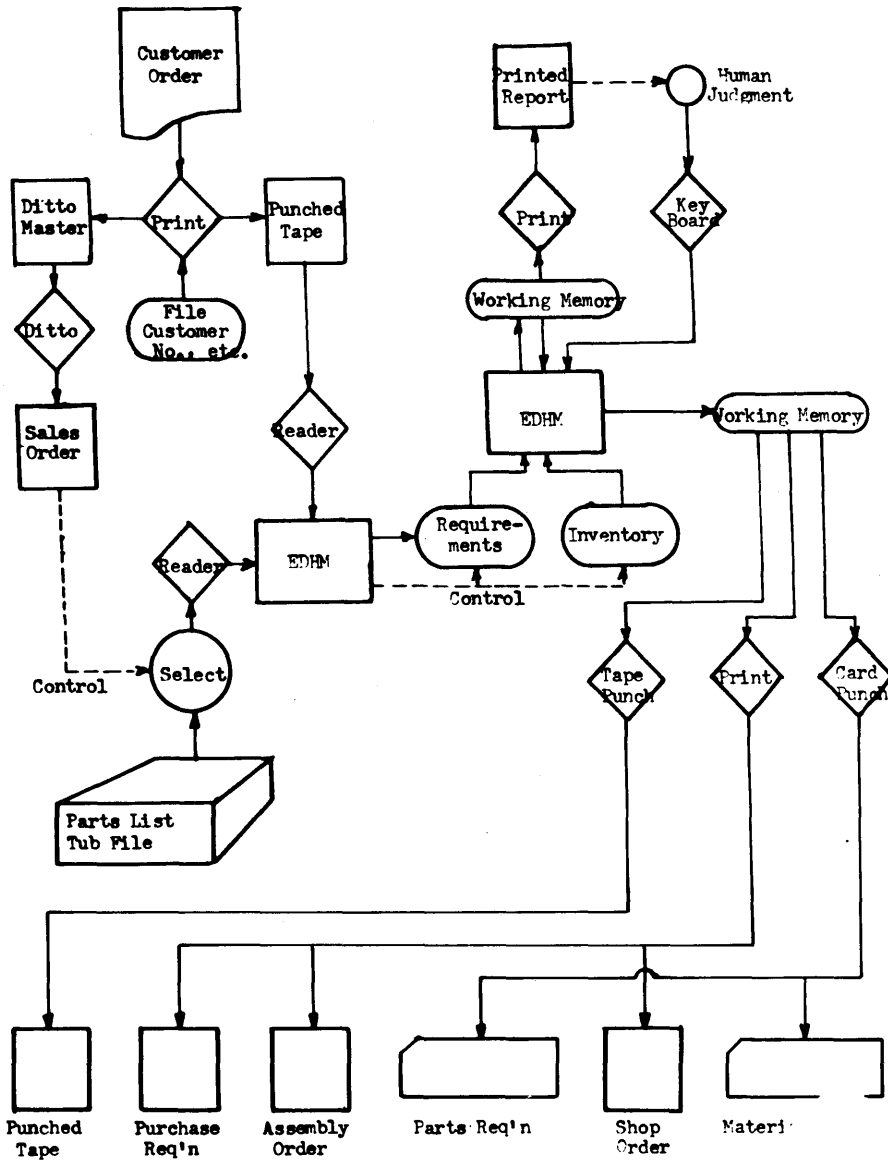

Fig. 2 - Posting Requirements and Ordering.

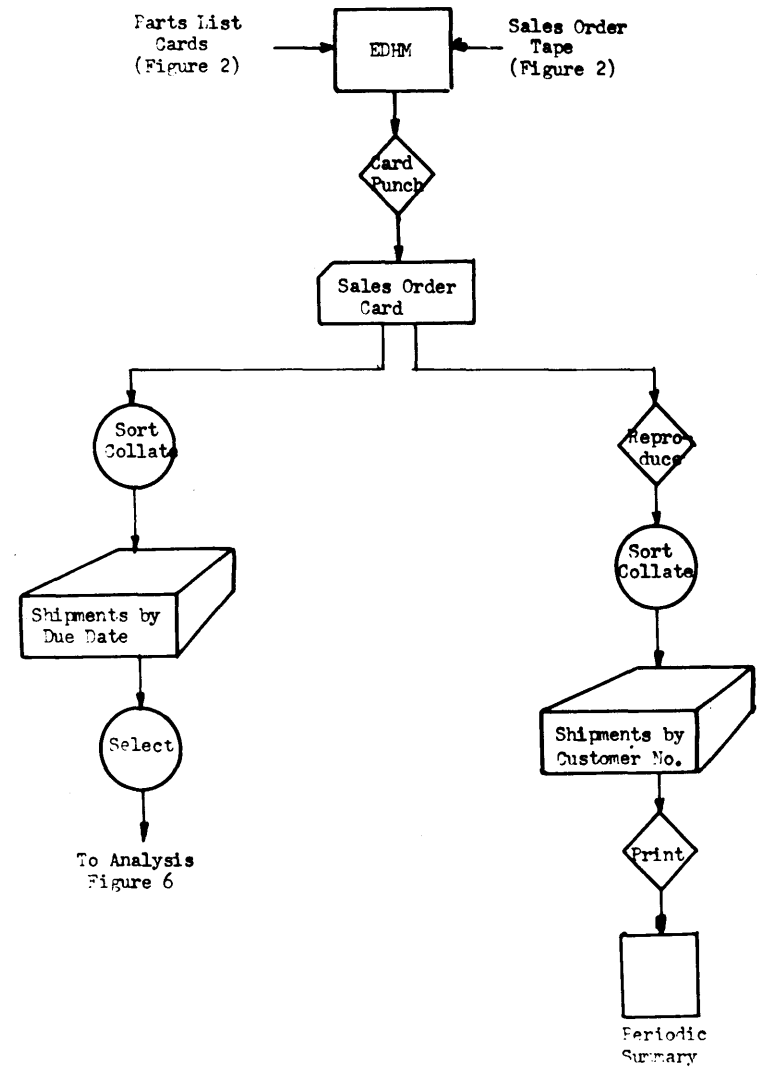

Fig. 3-Sales Order Cards.

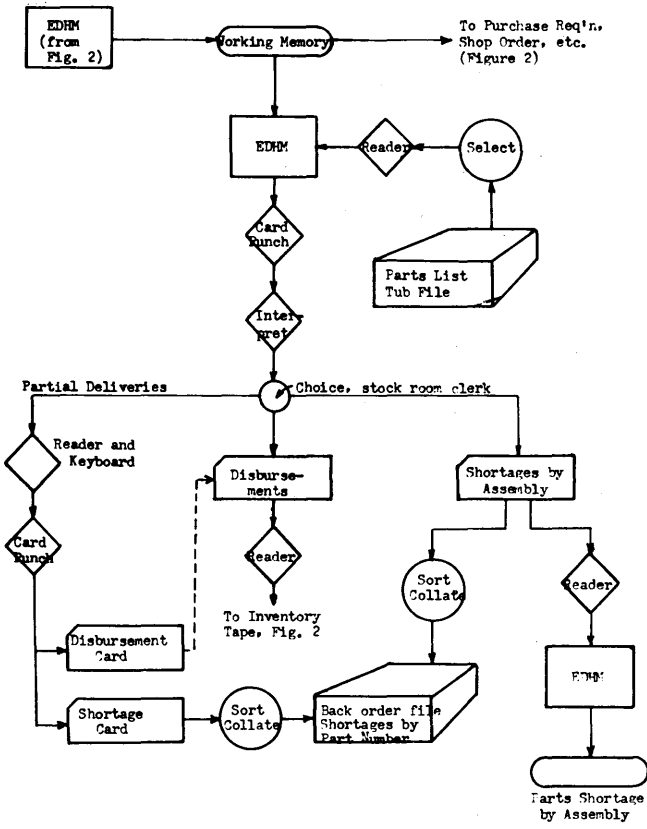

Fig. 4 - Assembly Order Procedure.

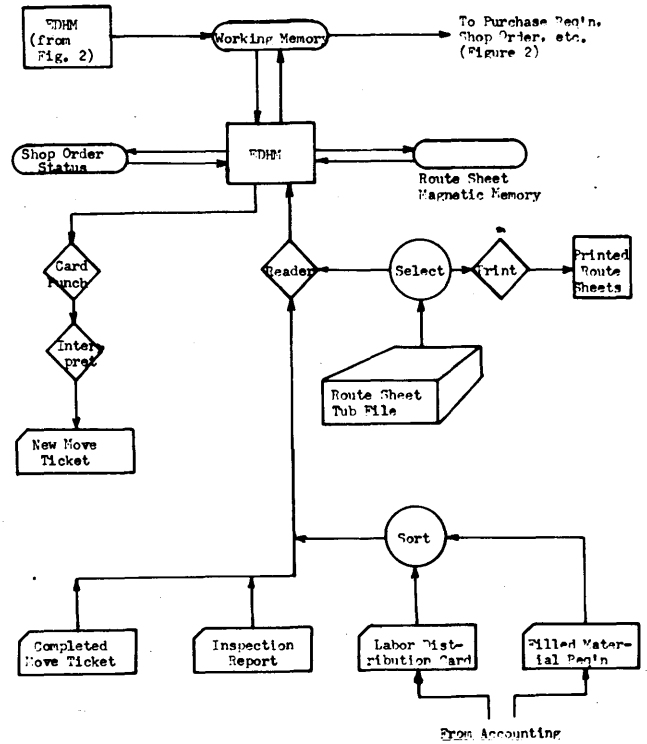

Fig. 5 - Shop Progress.

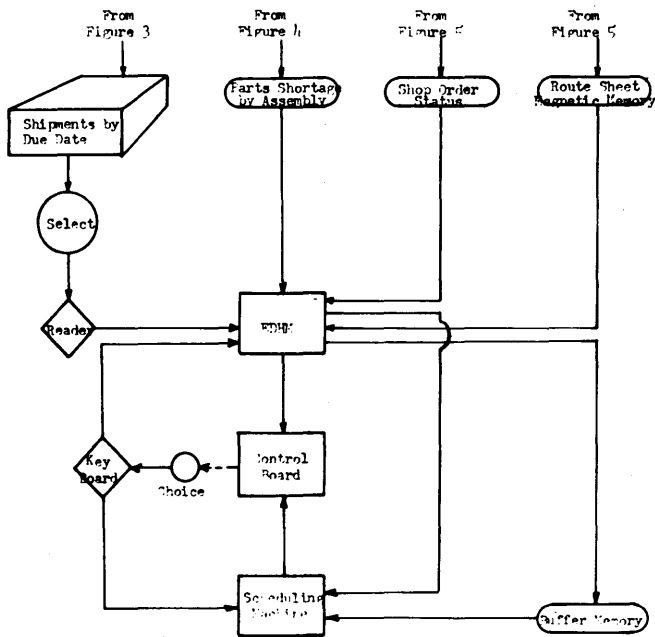

Fig. 6 - Control and Expediting.

REQUIREMENTS OF THE BUREAU OF OLD-AGE AND SURVIVORS INSURANCE
FOR ELECTRONIC DATA PROCESSING EQUIPMENT

Edward E. Stickell
Social Security Administration
Federal Security Agency
Baltimore, Maryland

The activities of the Division of Accounting Operations of the Bureau of Old-Age and Survivors Insurance have been referred to, upon occasion, as one of the biggest bookkeeping jobs in the world. Whether this condition is true or not depends on how it is measured. Certainly, by the yardstick of costs, it would not appear that the job is at all near the biggest. On the basis of comparisons similar to those made in business, the gross costs of operations represent only $\frac{1}{2}$ of 1 percent of total gross income. Furthermore, the system shows no signs of becoming the biggest in terms of cost. In a ten year period, an approximately 50 percent increase in basic work loads has been absorbed with no significant or compensatory increase in personnel. It is felt, therefore, that if the job qualifies as being one of the biggest in volume, it also might qualify as one of the smallest in terms of proportionate costs. However, regardless of how it is measured, the job represents a real challenge to those who administer it and to those who would furnish it with suitable electronic paraphernalia. For these reasons, the following problems are presented with pleasure at the opportunity and with confidence in the know-how represented at this conference to solder together whatever combinations of wires, tubes, diodes and transistors that are found to be necessary in each case.

The largest area of mechanical operation within the whole accounting system is in the processing each quarter of approximately 60 million entries received in random order to approximately 107 million accounts which are established in numerical order for ready reference. The end result of this work must permit rapid access to any one of the approximately 107 million accounts at any time except the instant at which a particular account is being posted. Such access is necessary in completing the approximately 755 thousand references made each quarter for such purposes as: processing claims for benefits, issuing statements of account, and making adjustments.

The ideal situation, of course, would be one in which each of the 60 million incoming items each quarter would be incorporated with the related account at the instant the new item is presented to the system. Key depressions by which punched cards now are produced instead would cause pulses to flow over wires to a device which would summon forth the designated account. This device would compare and post the entry or separately record it for clerical investigation if absolute identification of the entry with the account were not possible. Although, we often have seen yesterday's fantasy become today's reality when electronic principles have been established and applied, we cannot wait for as long as might be required to produce equipment suitable to this ideal. Hence, we must contain ourselves with projects of less ambition while the science progresses to this ultimate destination.

A sorting problem of considerable magnitude, therefore, is involved in arraying 60 million items each quarter for comparison with and entry into 107 million established accounts. Each of the 60 million items contains a nine digit account number and 61 digits of satellite information. Six words probably would be necessary, therefore, to express each of the 60 million items in electronic notation. We have not found, as yet, any way in which this sorting work might be done with any of the existing general purpose computers at a cost comparable to that of the rental of punched-card sorters. One of the presently most capable general purpose computers is reported to sort at speeds 5 to 10 times faster than that of a punched-card sorter. However, the cost factors greatly exceed these ratios. Attempts have been made to see how the cost of sorting by a general purpose computer might be reduced by some combination of other operations with the sorting. Unfortunately, it has been found that such possibilities so far have not been sufficient to surmount the cost disadvantages involved. It appears, therefore, that before sorting can be considered to be an efficient electronic process, either of two developments must occur. It must become possible to feed and extract data from general purpose computers at rates many times faster than at present or to have a low cost special-purpose computer specifically designed for sorting.

Although such sorting facilities are highly desirable, the present lack of them might not preclude some application of electronic equipment to this problem of entering 60 million items each quarter into 107 million accounts. A system which combines the advantages of punched cards and magnetic tapes might be found to be the most suitable answer for awhile. Under this arrangement, the data would be introduced and retained in punched card form until it had been sorted by account number and made ready for the actual posting to the established accounts. At this point, converters might be used to transfer the data from punched cards to magnetic tapes. Preliminary studies have been made of this possibility. Conclusions at this point are by no means final, and additional study is necessary based on more recently available operational data on card-to-tape converters and general purpose computers. However, some observations might be stated with reasonable validity at this time.

Card-to-tape conversion is an economical procedure if the operations performed thereafter in an electronic medium accomplish results at significantly lower cost than the punched card medium permits. The foremost requirement is that the cost of the card-to-tape conversion be absorbed. This requirement involves consideration of the cost, number, extent, and variety of the clerical and machine tasks which might be performed in one pass through an electronic computer but which would require separate and extensive treatment with punched card equipment, or by clerical workers. An additional requirement, insofar as the data processing problem previously discussed is concerned, is that the means be provided for frequent and random interrogation of the tapes.

Our preliminary studies show a possibility that two large punched card machine operations might be wholly combined and two clerical operations partially combined into one electronic computer operation after a card-to-tape conversion. The mechanical operations involve the collation and posting of the 60 million items to the 107 million accounts. The clerical operations involve the reconciliation of minor discrepancies in the spelling of names and

certain transpositions in the account numbers, and the notation and reconciliation of cases wherein females have changed their surnames by marriage or divorce after their accounts were established. Whether or not it is desirable to convert from cards to tape to accomplish these combinations of operations will depend on the results of further cost studies and on the finding of suitable means of obtaining high speed random access to data stored on electronic media.

The reason a means of high speed random access is so important to a substantial conversion to the electronic medium is that approximately 755 thousand random references are necessary each quarter to the data contained in the 107 million established accounts. Approximately 400 thousand of these references are made in connection with claims for benefits and 230 thousand for the issuance of statements to persons who request information concerning the amounts recorded in their accounts. It is necessary that this type of work proceed rapidly in order that the public might be served properly. Consequently, work cannot be scheduled and arrayed for reference to the file of accounts in blocks large enough to provide a considerable density of reference. Contacts with the file at widely scattered intervals are necessary. The time limits on the accumulation of work for reference purposes cannot be extended for much more than one hour per block. In addition to this situation, the references which are made involve the removal from file of a set of media, at present in the form of punched cards, for the mechanical preparation of abstracts of accounts and benefit computations for claims, and for the mechanical preparation of statements of account. The file to which these references are necessary contains, at present, approximately 20 billion alphabetical and numerical characters of information in punched card form. It appears that the present inability to obtain the discrete use of data when it is stored on reels of tape would seriously handicap the type of reference work just described. It would be necessary to move many thousands of reels in and out of the tape file daily. In numerous cases, the same reel might be required upon more than one occasion during the same day.

With a large number of inputs to a computer, it might be possible to work under such conditions provided the time required to load and unload the tape feeding devices could be substantially reduced. One company reports that a skilled operator can load or unload its machine in one minute, and that it is attempting to reduce this time to ten seconds. The success of this effort might make it possible to conduct these reference operations by manually carrying reels to and from a computer instead of relatively small quantities of punched cards to a printing tabulator as at present. However, it also would be necessary to have quite durable feeding mechanisms to withstand such constant use. There also would be a need for definite assurance that the frequent daily handling of the reels would not create serious problems of tears or kinks, or of dust and dirt becoming imbedded in the tape. For these reasons, the prospects of being able to conduct large scale random reference operations without equipment specifically designed for that purpose are not viewed with substantial optimism at this time.

A high-speed random access external memory of capacious design also might provide the means of applying electronic data processing equipment to another important area of reference work. The Division of Accounting

Operations maintains a file containing, at present, approximately 138 million flexoline strips showing the identities of holders of account number cards. Each strip contains a 9 digit account number, 25 digits for the name, a 3 digit Russell soundex code number, and 6 digits for the date of birth. Approximately 36 thousand references are made daily to this file of flexoline strips, principally to identify applicants for duplicate account number cards and wage earners who were reported under incorrect account numbers. This type of file was adopted and has been retained because it offered, and still offers to the present time, the highest speed of access to such information. For example, over 15,000 of the daily references are made to determine the account numbers of individuals so that duplicate account number cards can be issued. If the applicant for the duplicate card has given the same identifying information as he furnished originally, it usually is possible to locate the correct number in a matter of seconds.

Clerks who make the references to this file are required to do considerable walking, standing, reaching, and bending, notwithstanding the fact that the work is blocked to obtain the maximum density of reference. The conversion of the data in this file to a high-speed random access external memory appears attractive, not only from the standpoint of economy, but as a prospect for the elimination of a laborious type of work. For these reasons, we should like to see more attention given to this type of development. At the moment, we know of but two efforts which have been made in this direction. The one is the Notched-Disk Memory invented by Dr. Jacob Rabinow of the National Bureau of Standards; the other is the R.A.M. of the Potter Instrument Company. Both of these devices now are being studied to determine their possibilities. If other equipment of this nature exists, or is being planned, we should like to have whatever information is available.

Two areas have been found in which applications of electronic data processing equipment do not depend on the availability of equipment for high-speed random access to data stored externally. The one involves the calculation of the primary insurance amount of each claim that is processed; the other involves the development of the statistics which are necessary in certain operational, program planning, and other activities of the Bureau of Old-Age and Survivors Insurance. In the processing of claims, the computation of the benefit payments are based upon the claimants' work histories. The Social Security Act, as amended, requires the consideration of different base periods, the inclusion of credit for military service, and the use of a number of different formulae in the computation process. There are ten possible methods of computation; the one which gives the highest benefit must be selected. In this work, a computation card is punched for each of the pertinent possible methods of computation for each case. These cards are processed in an IBM Type 604 Electronic Calculating Punch Machine at the rate of 100 per minute.

A considerable amount of thought and attention has been given to the possibility of using electronic data processing equipment in the statistical operations of the Bureau. These statistics are used in analyses of the old-age and survivors insurance program and in administrative planning, and are used also by certain other governmental and private organizations for

general economic and demographic studies. The statistical operations involve the quarterly and annual processing of millions of punched cards obtained as a by-product of the regular accounting operations. In spite of the fact that a great deal of the basic source material is obtained as a by-product of the accounting operations, a substantial expenditure both in manpower and standard punched card machine is required to convert the basic cards received to final statistical data. Because the Bureau has not been able to obtain all the potentially available and required data, due to limitations of present equipment and time schedules, the Bureau is investigating the possibility of using electronic equipment to overcome these problems in the statistical program.

The investigation was started in cooperation with the National Bureau of Standards as part of a survey which also covered the investigation of possibilities in the accounting field. A number of test runs indicated some possibilities of money and time savings in the statistical operations of the Bureau of Old-Age and Survivors Insurance. However, these tests were run with but a few thousand accounts. Consequently, the results were not deemed conclusive enough to estimate savings which might be realized under actual conditions, when the number of accounts to be processed is substantially greater than in the test runs. Hence, a decision was made to conduct additional studies involving several hundred thousand punched cards. The Bureau of Old-Age and Survivors Insurance is arranging to have the Bureau of the Census perform two of the former's largest statistical tabulations on the Census UNIVAC machine. This machine will not be available for these tests until the Spring of 1953. In the meantime, staff members of the Bureau of Old-Age and Survivors Insurance are programming their statistical operations and will attempt to have the programs tested, so that the Bureau will be ready to proceed with the actual statistical operations as soon as the computer time becomes available.

In one of the two tests mentioned, approximately 300 thousand punched cards would have to be processed by conventional methods to obtain information on the economic and personal characteristics of about 100 thousand individuals with social security account numbers. In this operation, data are summarized for each individual. In addition, approximately fifty statistical tables are produced. This particular operation is similar to another annual statistical tabulation of the Bureau which involves ten times the number of cards and individuals and over 100 statistical tables. This latter operation comprises more than half of the total expenditure by the Bureau for compiling statistics. The Bureau is going ahead with the smaller statistical operations test on the assumption that the results can be used in making comparable estimates for the larger statistical operation.

In the second statistical test, approximately 25 thousand punched cards containing information on selected employers reporting under the old-age and survivors insurance program would be processed to produce approximately ten statistical tables by conventional methods. This operation is performed annually in this Bureau for approximately 3 million punched cards and is financed jointly by the Census Bureau and this Bureau. The results are a publication "County Business Patterns," which you might have

seen. Again, it would be necessary to draw inferences about the timing and cost for completing the latter operation on the basis of results obtained in the test.

This Bureau also has found that high speed printing equipment would be necessary to any large scale conversion to electronic data processing equipment. However, it appears that such requirements have become rather widely recognized and need not be argued for in this paper. In view of the comprehensive treatment given to this topic at the computer conference in New York this last December, it appears that satisfaction of this need lies at hand or at least is within reach in some form which might not require large reconciliations of expectations with the facilities which are offered.

Electronic scanning devices which could read pages of information and activate mechanisms to form characters and numbers in the form of holes in punched cards or magnetic patterns on electronic media also could be used somewhat extensively in the operations of the Division of Accounting Operations. A considerable number of the 60 million items received for credit to the accounts each quarter originate from returns of employers who use punch card equipment, typewriters, or addressograph machines. The printing on many of these returns is quite legible throughout. In addition, the information is spaced and aligned in a manner which probably would not require shifting beyond the range of the scanner. In view of the large turnover of personnel in key punch operations and the expense of key punch operations both in punched card and electronic data processing, a development of this kind would be most favorably received. For this reason, we are watching with considerable interest and anticipation a few developments which appear to have substantial prospects of application in this field.

In conclusion, it is felt that the requirements which have been stated in this paper are not altogether unique. Comprehensive market surveys by interested manufacturers probably would uncover quite similar needs in numerous other governmental agencies and in commerce and industry. For these reasons, this paper is presented with the hope that it might prompt such inquiry and possibly cause other potential users to come forward with descriptions of their requirements. Such information, when gathered, might form a basis for coordinated effort leading to the earlier satisfaction of a wide area of common needs.

Acknowledgment:

Acknowledgment and appreciation is due to Mr. S. D. Hearn, Division of Program Analysis, Bureau of Old-Age and Survivors Insurance, for his having prepared the discussion of the statistical problem included in this paper.

References:

1. Marc Shlowitz, "Analysis of the Application of Large-Scale Digital Computers to a Sorting Process." Part 1: "The Quaternary Mesh Sorting Method." National Bureau of Standards Report #1519, March 1952.
2. R. B. Marimont and J. W. Chin, "Estimates of Sorting Rates for Digital Computers." National Bureau of Standards Report #1875, August 1952.

THE PROCESSING OF INFORMATION-CONTAINING DOCUMENTS

George W. Brown and Louis N. Ridenour

International Telemeter Corporation

Los Angeles, California

The Problem

General Remarks

Much recent attention has been paid to the promise that digital computer techniques will simplify, speed up, and cheapen various sorts of large-scale information processing in business and industry. Only a few actual applications of this sort have so far been attempted, probably for two main reasons. First, punched-card machines are already so highly developed that, despite the potentially greater speed of the newer electronic techniques, it is difficult to introduce novel ways of accomplishing what can now be done by standard business machines. Second, and probably more important, appropriate input and output equipment to couple the world of the digital computer to the world of men often does not exist. To use a computer for scientific or engineering calculations, it is sufficient to provide it with input in the form of a device for reading punched cards or tape, and an output in the form of an electric typewriter or a card punch. Most existing computers have terminal equipment no more sophisticated than this. To use such a machine for accounting purposes, however, requires a far more imaginative solution of the input-output problem; a satisfactory solution can be achieved only on the basis of a deep understanding of the nature of the accounting activity that is being mechanized.

Thus, before the automatic processing of information can be fully successful, means must be provided for imparting the pertinent information to the machine in a form suitable for automatic handling, and for extracting the processed information in useful form. In many practical situations, the problem is made still more difficult by the fact that the original documents containing the information to be processed themselves have a significance, and must be physically handled, routed, or sorted on the basis of the information that they contain. It is an application of this sort that we wish to discuss.

While documents are often used only as vehicles for information, and can be replaced by other documents carrying the same information, there are many other instances in which the original document itself possesses a logical or legal significance, so that it must be preserved throughout an operation which may be rather complicated. In the case of a bank check, for example, the original bit of paper constitutes at all times the legal evidence of an obligation which is fully discharged only when the check is cancelled and returned to the man who drew it. Bank checks must be physically conveyed from hand to hand until they are deposited in a bank; thereafter they must be taken through a series of sortings and concurrent proof and bookkeeping operations, until the bank on which each check is drawn returns each check to its originator.

For an example of another kind, consider the postal service. The U. S. Post Office undertakes to transmit from sender to addressee each letter properly posted, without transforming or even inspecting the contents. Indeed, the inviolability of first-class mail is jealously guarded by the postal authorities, except in such special situations as that which required the censorship of overseas mail in wartime. Except in the case of V-mail, which had as its object condensation of the bulk of letters going abroad, no large-scale attempt has ever been made to impose on the letter-writing public a scheme of transforming and transmitting the information contained in a letter, in lieu of the straightforward transmission of the letter itself. Even when the art of electrical communication is more highly developed than it is today, a tear-stained note on scented paper will probably have more emotional significance to its recipient than would a transformed message transmitted with the speed of light!

Not only bank checks and letters, but also any original papers evidencing indebtedness or obligation, must be processed in a similar fashion. Thus department-store or oil-company charge slips, chits at hotels and clubs, and similar papers characteristic of the increasing public use of credit, must themselves be handled while the information they contain is concurrently being processed.

A Specific Application

Let us consider more closely a problem of the sort mentioned above: the handling of checks by a bank. We shall suppose that the bank has several or many branches, and that the volume of check clearings is sufficient to make it desirable for the bank to perform a head-office clearing-house operation within its own organization; the generalization to other situations will be easy.

At a given branch bank, checks accompanied by deposit slips are handed or mailed in by depositors. A first proof and sorting operation is performed at the branch, in which the deposit-slip total is verified against the independently run-up total of the individual checks belonging to that deposit slip. The proof-machine operator at the same time sorts the checks into a few gross categories; for each category a printed tape listing each item in the category is prepared.

Periodically, checks drawn on other banks or branches are bundled up, in the gross categories mentioned, and forwarded to the head office. With each such bundle goes a printed tape listing the items contained in it; this tape plays for the head office the role that the deposit slip played at the branch. In the head office there is performed a proof and sorting operation precisely similar to that previously done at the branch; the tape total is compared with the individually run total of the separate checks in a batch, and the batch is further sorted according to the bank of origin of each check.

The proof machines which are sometimes used for this head-office operation may have either 24 or 32 compartments, depending upon which of two models is used; for each compartment a tape is printed listing the items it contains. Since checks may require sorting to many more than 32 destinations, it is clear that the average check must be run through the head-office proof-machine operation more than once.

Every step in the clearing process is dependent on the information contained in the check. This information is of two principal sorts: the amount entered on the face of the check controls the proof calculation, while the sorting process is governed by the information regarding bank of destination, which is conventionally printed at the top of the check and is also presented as a bank number assigned to the bank under a nation-wide standard scheme. The operators who run the proof machines perform a function which is logically indistinguishable from translation; they read the entries on the face of the check and inform the machine (by punching its keys) as to what those entries say. That is, they are performing a translation from the printed and written language used by human beings to the language understood by the proof machine.

In default of a machine for reading print and handwriting, which we do not yet have, one such act of translation must be performed by a human being. Once the translation has been done, however, the preservation of its results in a form that a machine can read will eliminate the need for further human agency in the later stages of the proof and sorting operation. There are several ways in which this preservation can be attempted; let us examine them.

Proposed Solutions

Punched-Card Checks

The most obvious suggestion is that the information-bearing document be itself a standard punched card, so that conventional business machines can perform the processing of the document and of the information it contains. Bank checks of this sort are indeed available, and are in fairly wide use. The fact that the punched-card check is not universal suggests that it may not be an ideal solution to the problem; if this conclusion is correct there are at least two principal shortcomings of the system which suggest themselves as reasons for it.

First is the rigidity of the system with respect to the physical form of checks. Present custom permits the depositor of a bank to choose his own style of check, within fairly wide limits of size, shape, and paper stock. Further, it permits him, when no blank check form is available to him, to write a counter check, to alter a check printed as belonging to a bank other than his own, or even to write a check on any piece of blank paper that may come to his hand. While it might be possible to re-educate the public not to expect this latitude of service from the banks, it appears that few banks are willing to take steps which limit the service they give the customer, so long as other banks are putting heavy emphasis on greater customer service.

A second and more fundamental difficulty with the punched-card check system stems from the fact that the checks spend a substantial time in passing from hand to hand, out of control of the bank, before they are finally deposited and must be cleared. Maltreatment or accidental damage occurring prior to deposit cannot be controlled by the bank, and, if it is serious enough to prevent even a small percentage of punched-card checks from feeding properly through the machines, such damage can very quickly eliminate the savings realized by installing a punched-card check system. The damaged punched-card check cannot be replaced by a good card carrying the same information (as a damaged card used in an accounting system would be), because it is a check -- unique evidence of a legal obligation. Instead, the damaged card must be carried by hand through all the operations

necessary to clear it; this is sufficiently troublesome so that even a tiny fraction of damaged cards will make a card-check system impractical for general use.

Parallel Control by Punched Cards

It has been suggested that a punched card might be prepared to accompany a check through the clearing operation. This card, into which would be punched all the pertinent information contained on the check, could be prepared at the time of the first proof operation. Corresponding stacks of these cards and of the documents that they represent would then be handled individually and simultaneously, through common control by card readers. Thus two sorters would operate side by side, the one sorting cards and the other, controlled by the first, sorting checks.

So far as the authors are aware, this scheme has never been used, which may indicate that its manifest drawbacks are so serious that it is not practical. Among these drawbacks are the following:

1. Automatic feeding and sorting equipment capable of handling documents of a wide range of size, shape, stiffness, and degree of preservation is assumed by the scheme. The required equipment poses a variety of difficult mechanical problems.

2. Two corresponding processes must be kept in synchronism, without any check on proper operation or control over the individual identities of the documents being sorted.

3. Any accidental disordering of either stack -- documents or cards -- can be repaired only by an item-by-item inspection of the disordered stack, a costly and time-consuming process.

4. The cost of the punched cards required by this scheme -- between one and two mills per card -- may be a non-trivial part of the total cost of the system. An efficient internal clearing operation can be run manually for less than five mills per item handled.

Coding Information into an Ordinary Check

It has occasionally been suggested that the necessary information carried by a check be coded directly into the check itself, in a form suitable for machine reading. While this idea does not have the rigidity of the punched-card check scheme, it has the damaged-item difficulty in an exaggerated form. Punched cards are standardized and carefully controlled precisely because their uniformity makes the design of reliable handling equipment less difficult than it would otherwise be. Machinery to handle automatically a heterogeneous mixture of documents of various shapes, sizes, and degree of preservation would be very difficult to make; and the usual check form, being of flimsier stock than that used for punched cards, would be far more susceptible to damage which would prevent it going through the machines at all.

The Information-Bearing Attachment

The foregoing discussion makes it almost self-evident that the problem can be solved by preparing and affixing to the check, at the time of the first proof operation, an information-bearing attachment which contains in machine language the pertinent information written and printed on the face of the check. This has the advantages of the punched-card check system -- standardization of the size, form, and style of the thing to be fed and read by the machine, in this case, the attachment -- without the disadvantages. For the attachment, being prepared after the check is deposited, remains under the control of the bank throughout the clearing operation, and it can be preserved from damage if the bank simply takes adequate pains to protect it. Further, no restriction is put on the customer's preparation of checks; the attachment can be affixed to any sort of paper whatever.

Once the attachment is prepared and affixed to the check or other document, all further human reading or handling is unnecessary. Since the attachment is prepared at the time the document enters the mechanized system, a fresh and reliable medium is available for carrying the information in machine language, which can take the form of perforations, marks, signals in magnetic recording media, etc. The size, weight, and information code of the attachment are standard, so that positioning, feeding, and handling operations can all be performed on the attachment, without reference to the size, shape, degree of preservation, or nature of the original document which is carried along when the attachment is handled. To simplify the problems of mechanical design, the attachment can be provided with special marks, slots, or holes to assist in indexing it as it is handled.

It is also of importance to observe that the information-bearing attachment is not the important document. It contains information, and that is all. If that information is incorrectly entered on the attachment, or if the attachment becomes damaged so that it will not feed properly through the machines, the old attachment can be replaced by a fresh new one, simply at the cost of the effort required to make a new attachment. There is no necessity to carry checks by hand through the clearing operation, as is required in the case of damaged punched-card checks.

The International Telemeter Corporation is currently developing equipment for mechanizing the clearance of checks on the basis of the attachment concept. The attachment is prepared in the bank or branch of deposit, at the time the deposit items and deposit slips undergo the first proof operation. According to present practice, the amount of each check is entered on a keyboard, and the bank of origin is noted, though not necessarily entered. At the expense of entering the bank identification number from the face of the check during the first proof operation, all further human handling can be eliminated from the check-clearing process.

According to our preliminary designs for the actual machines which prepare and affix the attachments, and do the later sorting and proof operations automatically, the attachment will be a short length of seven-hole punched tape, affixed to the check by a heat-sensitive adhesive. The reading of the attachment

will be done by a photoelectric reader, in the automatic stages of the clearing operation which follow the step of preparing the attachment.

The upper limit on the operating speed of the automatic proof and sorting machines is set by the necessity for physical transport of the checks. It is a design objective to handle them at ten items per second. This speed is so low that the concurrent logical processing of information, required by the proof operations which must accompany sorting, can go much faster. It is accordingly our intention to let one magnetic drum and its associated logical circuits serve a number of sorting stations, perhaps four or five.

The machines now being designed and constructed are primarily intended for use in the automatic clearance of bank checks, but it is our aim to keep the mechanical design sufficiently general so that the same machines will handle other types of documents. Only the logic will need to be altered to use these machines in another application.

The attachment concept clearly lends itself not only to the proof and sorting of checks for their clearance to the bank of destination, but also to the bookkeeping, posting, and sorting operation that the bank of destination must perform before returning cancelled checks to the depositors who have drawn them. At present, we are not including this operation in our considerations and designs, though it seems that this would be a straightforward extension of the technique.

AIRPLANE LANDING GEAR
PERFORMANCE SOLUTIONS WITH
AN ELECTRONIC ANALOG COMPUTER

D. W. Drake and H. W. Foster
Research Group Engineers
Lockheed Aircraft Corporation
Burbank, California

Introduction

The typical airplane landing gear is basically a rather simple shock absorbing device whose characteristics can normally be described with considerable accuracy by a system of three or four simultaneous differential equations. However, due to the fact that the system includes a number of non-linear and discontinuous elements, it has been impractical to obtain analytical solutions of the equations without making simplifying assumptions which severely limited the value of the results. For this reason the shock strut energy absorbing characteristics have generally been developed experimentally by laboratory drop tests of an actual landing gear, and the landing gear evaluation has been accomplished by extensive laboratory and flight tests. This design method is obviously far from ideal, since all structure effected by landing loads must originally be designed to assumed landing gear characteristics, and the landing gear test results do not become available in time to allow design changes to be made economically.

The development of cheap and reliable electronic differential analyzers suggested that practical analytical solutions of landing gear characteristics might now be possible. To investigate this possibility a study was initiated of a landing gear for which relatively complete drop test data were available. This paper reports the results of the study and compares the drop test results with analytical solutions obtained on Boeing Electronic Analogue Computers. The work was done at Lockheed Aircraft Corp. by the Structures Research and Mathematical Analysis Departments.

Description of Landing Gear

A typical main landing gear system consists essentially of a large mass (usually considered to be one-half the mass of the airplane), coupled through a shock absorber (oleo strut) to a wheel and tire assembly. The shock absorber itself normally consists of a cylinder and piston assembly so arranged that closure is resisted by (a) the flow of oil through a fixed or variable orifice to provide a force which is a function of the velocity of closure, and (b) by a gas pressure providing a force which is a function of the closure displacement. The shock strut cylinder is rigidly attached and braced to the airplane structure, but the shock strut piston carries fore and aft (drag) and side loads in cantilever bending; closure of the strut is therefore also resisted by a friction load of significant magnitude.

The most critical function of the landing gear, the function that controls the design of the shock strut, is to stop the vertical motion of the airplane during landing at a controlled deceleration rate which limits the forces and accelerations on the airplane structure to values within the design strength envelope. It is normal to design for airplane sinking speeds of the order of 10 ft/sec and to require the landing gear to limit accelerations to values not

to exceed 1-1/2 to 3 times gravity. During the impact period the airplane is still flying, that is, all or a large percentage of the weight of the airplane is still carried by the wings, so the landing gear is required to absorb little if any more than the kinetic energy stored in vertical velocity.

The most important degrees of freedom for defining the landing gear characteristics are:

1. Vertical motion of the airplane mass with respect to the landing surface.
2. Vertical motion of the "unsprung" mass (wheel, tire and piston) with respect to the landing surface.
3. Fore and aft horizontal motion of the unsprung mass with respect to an airplane reference axis.
4. Rotation of the wheel and tire assembly about its axle.

The first two of these are, of course, first order motions with respect to the primary function of the landing gear. The third and fourth, while not strictly first order motions with respect to the shock absorbing characteristics of the landing gear, are responsible for some of the critical landing gear design conditions, and may, in addition, have important effects on the shock strut characteristics through their effect on friction forces.

Landing Gear Equations

The landing gear system was idealized as shown in Figure 1. This figure also defines the symbols used in the following discussion. The effect of drag deflection on geometry is neglected. The airplane mass, M_1 , is assumed to be constrained to move vertically without rotation. The mass, M_2 , is constrained to move relative to lower portion of the gear in the "Z" direction only.

The equations of motion for the idealized gear are:

$$F \sin \theta + SK_2 \cos \theta + M_2 \ddot{h} - P_0 + K_3 \dot{h} = 0 \tag{1}$$

$$K_1 v + M_2 \ddot{v} + SK_2 \sin \theta - F \cos \theta = 0 \tag{2}$$

$$M_1 \ddot{x} + F \cos \theta - (1-L)W = 0 \tag{3}$$

and the displacements are defined as

$$h = y \sin \theta + z \cos \theta \tag{4}$$

$$x = v - z \sin \theta + y \cos \theta \tag{5}$$

The force resisting compression of the oleo is the sum of an orifice force, a gas pressure force, and a friction force,

$$F_2 = F_0 + F_a + F_f \tag{6}$$

Hydraulic Orifice Force

The orifice force was assumed to be

$$F_o = \left(\frac{\dot{y}}{B}\right)^2$$

(7)

where \dot{y} is the velocity of strut closure and B is proportional to net orifice area. B is constant in a strut with a plain orifice but variable with strut position when a metering pin is used. The direction of this force is always such that it resists piston motion, i.e., it has the same sign as \dot{y} .

Gas Pressure Force

The gas pressure force is a function of shock strut stroke, y, and is defined by the following equation:

$$F_a = A \left(\frac{E}{E-y}\right)^n$$

(8)

where E is the fully extended shock strut volume divided by the strut area, A, and n defines the type of compression. Reference 1 suggests that n = 1.1 is a good approximation for most gears, and that value was used in this investigation. In the computer, Eq. 8 was approximated by three straight lines using limiters as shown in Figure 2. This force always acts to extend the piston and hence is always positive.

Shock Strut Friction Force

The drag force applied to the shock strut piston produces a shear force and a moment in the piston, and in addition, the vertical forces produce a moment in the piston. These forces are reacted by the upper and lower bearings in the oleo. The bearing loads will, of course, vary with strut stroke since the reacting moment arms change. The friction force resisting closure of the oleo is the result of these bearing loads, and may be defined as

$$F_f = \mu_2 \left[\frac{K_2 S (2L_2 + L_1 - y) + 2FL_3}{L_1 + y} \right]$$

(9)

See Figure 3. A value of .05 was used for the coefficient of friction, μ_2 , on the basis of some limited data collected on other struts. The friction force always acts to resist motion of the piston and hence has the same sign as \dot{y} .

Fore and Aft Drag Force

In an airplane landing during the fraction of a second after contact, the landing gear wheel assembly is accelerated in rotation from zero to a peripheral speed equal to the airplane forward velocity. In drop tests in the laboratory this phenomenon is simulated by rotating the wheel assembly backwards before dropping, and this procedure was assumed in the computer. In this fashion the same wheel speed change and hence energy exchange is obtained as in a landing. The gear drag forces are caused by this wheel acceleration, which in turn, is caused by the friction force between the tire and the landing surface. The coefficient of friction is assumed to be constant for design purposes but varies considerably in practice. See Reference 2.

The friction force is defined as

$$P_D = \mu_1 K_1 v \quad (10)$$

$K_1 v$ being the normal force between the tire and landing surface. Since the torque produced by this force is reacted by the wheel assembly inertia, the gear feels this force as being applied at the axle as indicated in Figure 1. The Eq. of rotational motion of the wheel assembly is

$$P_D (R - v) = I \dot{\omega} \quad (11)$$

and

$$\omega = \int \dot{\omega} dt$$

When the wheel speed change is completed, the tire no longer slides relative to the surface and P_D becomes zero. In the computer setup this was accomplished by using Eq. 10 for P_D until ω changed sign and then making P_D equal zero.

After spin-up, as the gear oscillates fore and aft, the wheel rolls or slides, and this motion, plus any damping in the gear, absorbs energy from the drag oscillation. These effects were lumped as the $K_3 h$ term of Eq. 1.

Fore and Aft Oscillation Frequency

The natural frequency of the gear in the drag direction varies with the position of the piston in the shock strut, the system being much stiffer when the piston is bottomed than when it is fully extended. Some available test data suggest that a gear will be approximately three times as stiff fully compressed as when fully extended and that a linear variation with strut stroke is a reasonable approximation of the variation. Lacking better information, the fore and aft spring constant, K_2 , is defined for these tests as

$$K_2 = K_{FE} \left(1 + \frac{2y}{y_{max}} \right) \quad (12)$$

Discontinuities in Shock Strut Action

A landing gear has several discontinuities in its action, mathematically speaking. Initially the air force and the friction force hold the shock strut fully extended against mechanical stops until applied force exceeds the preload, i.e., the shock strut has one less degree of freedom during this period. This fact permits the use of Eq. 2 for defining the strut force, F_1 , during the initial period. In the computer, the strut force, F , used in the differential equations (Eq. 1, 2 and 3) was F_1 from Eq. 2 until $F_1 - F_2$ changed sign; then, by means of a relay, F was taken as F_2 , the force resisting closure of the strut.

Another discontinuity occurs when the shock strut bottoms. This discontinuity was simulated by the very steep line in the limiter generation of the air force which had the effect of making the strut very stiff and forcing any downward motion of M_1 into tire deflection.

A discontinuity in the fore and aft motion occurs because in an actual landing gear there is some looseness or slop in the system which appears as deflection without load change as load direction is reversed. Such slop will generally

increase the dynamic component of the drag load. This characteristic was simulated with a limiter by relating the motion of M_2 relative to the piston, Z , to the drag spring deflection, S , as shown in Figure 4.

Computer Set-Up

Following normal differential analyzer practice, the basic system equations were solved for the highest derivative of each variable. The circuit used for generating and relating the variables is shown in Figure 5. The computer work was done in the Mathematical Analysis Group using four of their Boeing electronic analogue computers, a Miller photoformer, and Goodyear servo multipliers. Data were collected as a function of time on a two-channel Brush recorder and load vs. strut stroke curves were plotted on a Dumont 304H oscilloscope and photographed with a Land camera.

Test Landing Gear

The test landing gear is shown in Figure 6, installed for drop testing. The shock strut is metered by a fixed orifice. The axle centerline passes through the strut axis but the center of the tire is 16.1 inches to the side of the strut axis. This value was used for L_3 . The system constants used in the computer simulation are tabulated in Table I.

The system was set up on the computer and the constant, B , in the orifice equation was adjusted for best agreement with the drop test vertical load vs. strut stroke curve for a 29,500 lb. drop weight, 10 ft/sec drop in the nose down attitude. The drag spring constant, K_{FE} , was then adjusted to match the fore and aft natural frequency indicated by the drop test data for this same drop. A slop of $\pm 1/8$ in. was found to produce about the same discontinuity in passing through zero drag load, as indicated by the drop test data. The constant, K_3 , in Eq. 1 was adjusted to match the drag load decay rate after spin-up for the reference drop. The drop tests of this gear were made on a concrete reaction surface. As the coefficient of friction developed by this surface varied during each drop, an R-C circuit was adjusted to provide a variation in the applied drag load, F_D , more closely simulating the drop tests. See drag force comparisons in Figures 16 and 17.

With the system adjusted to match this one drop test, data were obtained for a range of contact velocities at a 29,500 lb. drop weight, nose up and nose down, and at 33,750 and 38,500 lb. drop weights in the nose down attitude. Plots comparing the computer and the drop test data are presented in Figures 7 through 17.

In these figures, it is seen that the simulation of vertical load characteristics is rather good, although the further the test condition gets from the drop for which system was adjusted, the larger the differences between the computer and drop test data. This is particularly noticeable at the high drop weight where the strut force climbs well up the air pressure curve near strut bottoming. Part of the error in this region may be explained as poor simulation of the air curve in the computer. See Figure 2. The drag load data comparisons show that the character of the spin-up and springback phenomenon was fairly well simulated but that the magnitudes of the drag loads in the computer are consistently lower than in the drop tests.

The detail reasons for these differences are not known but are probably of two types: (1), it was necessary for lack of better information to make some unsubstantiated estimates of some of the system constants, and (2), there is very little detail information on the various phenomena present in a gear during landing so that some of the equations describing the system are at best only rough approximations. In addition, it has been shown (Ref. A) that variations as high as 15% may be expected in conducting so called identical drop tests, so some scatter of results would be expected in any case.

In view of these factors, it is felt that, in the present state of the art, the simulation of the test landing gear is quite good.

Discussion of Results

The significant result of this investigation is the successful practical solution of landing gear mathematics describing landing gear action in detail. Any lack of accuracy in the simulations was due to lack of knowledge of the gears and not due to limitations of the computer. In other words, given an accurate functional knowledge of landing gears, accurate simulations of a given gear can be expected on the computer.

Most experimental work with landing gears in the past has been directed toward determining the overall characteristics of a given gear under specified test conditions. Very little work has been done investigating the detail operation of landing gears because little practical use could be made of the information if it were available. This investigation suggests that the differential analyzer provides a means of overcoming the problem of handling landing gear mathematics and hence emphasizes the need for more basic information on landing gears.

In setting up the gear simulations, it was apparent that more knowledge was needed of the following gear phenomena:

1. The relation between the orifice force and fluid velocity through the orifice.
2. The exponent to be used with the air compression equation.
3. The source of strut friction and the range of variation of strut bearing coefficients of friction.
4. Correspondence between effective and calculated tire moment of inertia.
5. Variation of drag rigidity with strut stroke.
6. The amount of slop to be expected with different gear configurations.
7. The magnitude of damping of fore and aft oscillations when the tire is on the ground.

Most of these items can be rather simply evaluated during drop tests. After such information has been obtained in specification drop testing of a number of gears, it seems probable that landing gear installations may be rather accurately evaluated during the early stages of design, and it will probably be possible to confine testing of specific gears to the determination of accurate gear constants,

after which broad range survey tests can be done in the computer where it will be possible to include other airplane structure beyond the landing gear.

References

1. NACA TN 2477, Sept., 1951, "Investigation of Air - Compression Process During Drop Tests of an Oleo Pneumatic Landing Gear."
2. "Friction Surfaces for Spin-Up Simulation in Landing Gear Drop Tests," by D. W. Drake, Trans. ASME, Oct., 1952.

TABLE I
LANDING GEAR CONSTANTS

UNITS	CONSTANT	TEST GEAR.		
		N.D.	N.D.	
Degrees	θ	4°12'	13°12'	
None	L	2/3		
Lbs.	A	7700		
ins.	E	17.46		
ins.	L_1	13.7		
ins.	L_2	22.0		
ins.	L_3	16.1		
ins.	R	28.3		
ins.	y_{max}	16.0		
None	μ_1	.25		
None	μ_2	.05		
in.-lbs.-sec ²	I	419		
Lb./in.	K_{FE}	5000		
$\frac{\text{lbs.-sec}^2}{\text{in.}}$	M_2	2.63		
None	n	1.1		
$\frac{\text{lbs.-sec.}}{\text{in.}}$	K_3	6		
Lbs.	Drop Weight	29,500	33,750	38,500
$\frac{\text{lbs.-sec.}^2}{\text{in.}}$	M_1	76.5	87.5	99.8
Lb./in.	K_1	8,400	10,200	12,100

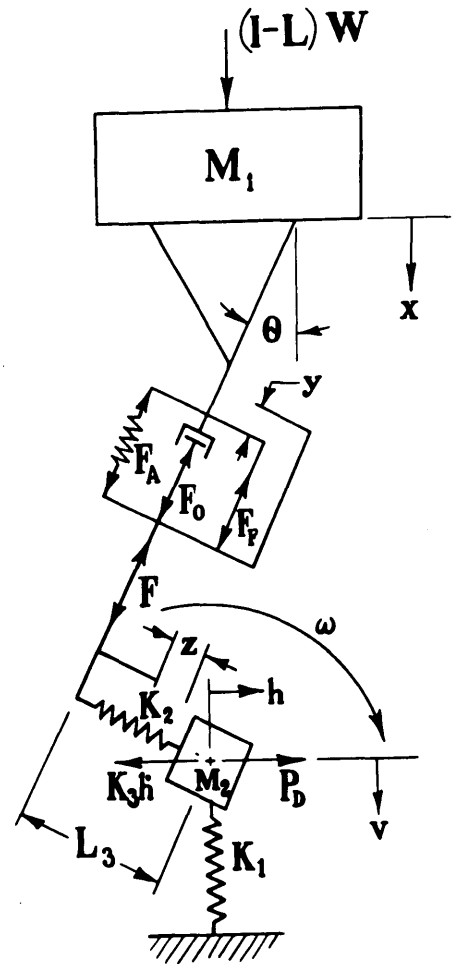

Figure 1 - Landing Gear Schematic Diagram

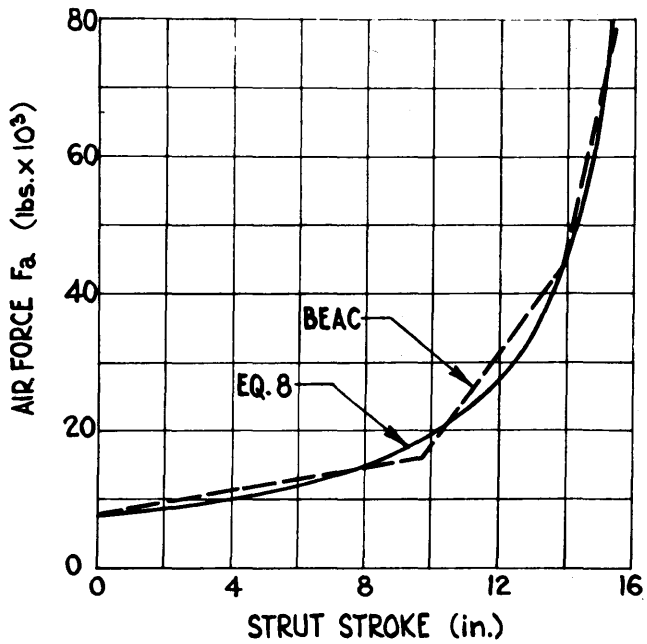

Figure 2
Approximation Used for Gas Pressure Force

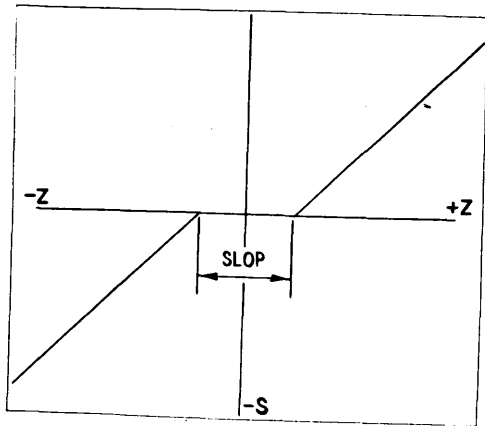

Figure 4
Simulation of "Slop" in Fore and Aft Motion

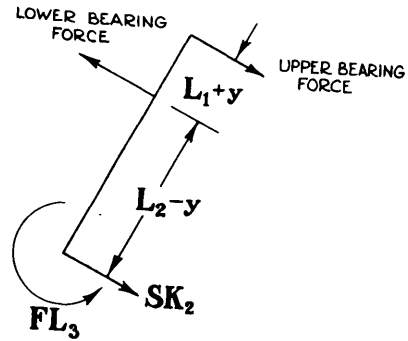

Figure 3
Schematic Diagram Defining Friction Force

ELECTRONIC ANALOG SIMULATION OF LANDING GEAR

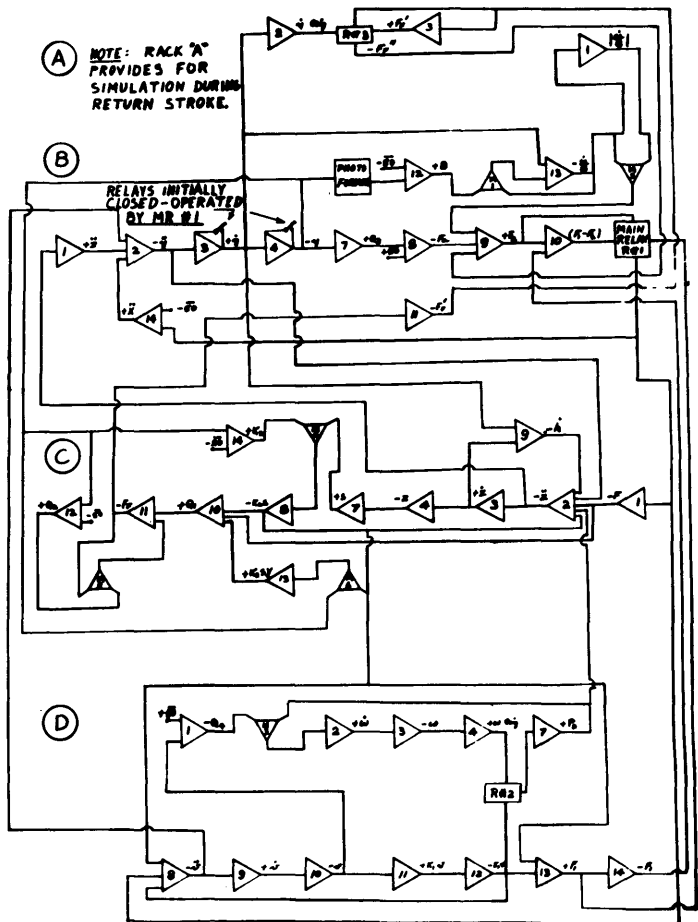

Figure 5 - Electronic Analog Simulation of Landing Gear

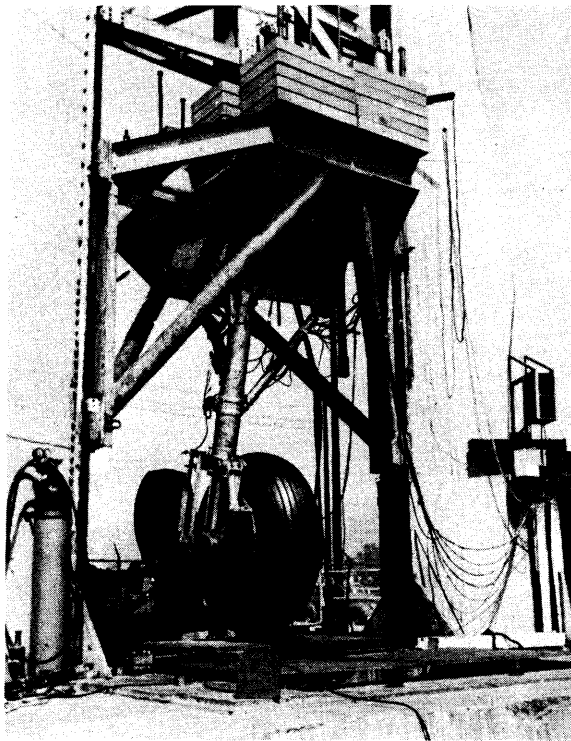

Figure 6 - Photograph of Test Landing Gear Installed in Drop Test Tower

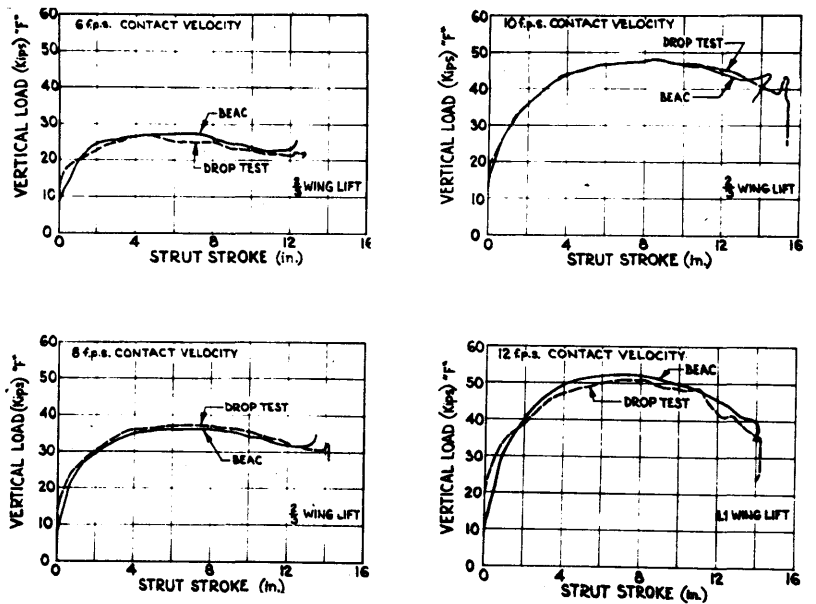

Figure 7 - Vertical Load Versus Shock Strut Stroke
29,500 Lbs. Test Weight - Nose Down Attitude

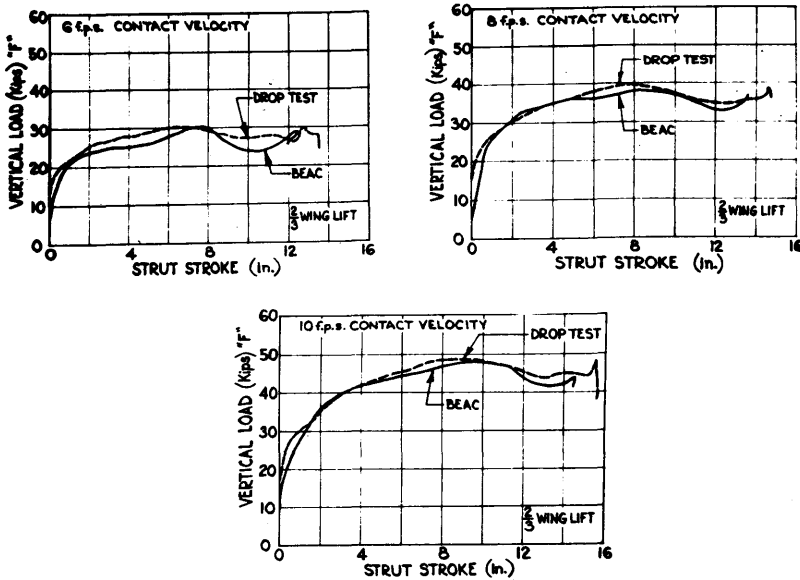

Figure 8 - Vertical Load Versus Shock Strut Stroke
29,500 Lbs. Test Weight - Nose Up Attitude

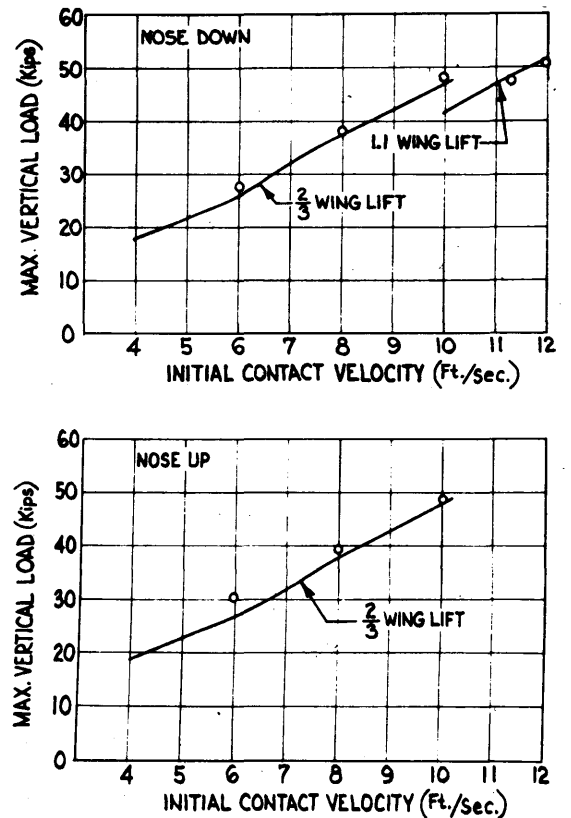

Figure 9 - Maximum Vertical Load Versus Contact Velocity
1000 RPM Initial Wheel Speed
29,500 Lb. Test Weight

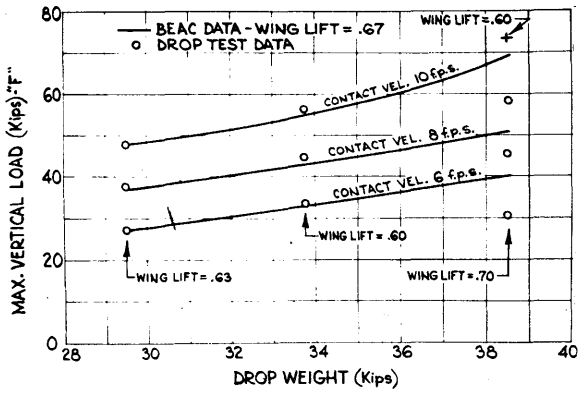

Figure 10 - Maximum Vertical Load Versus Test Weight
1000 RPM Wheel Speed - Nose Down Attitude

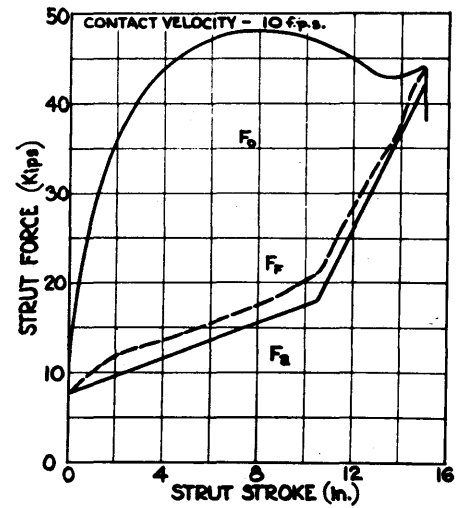
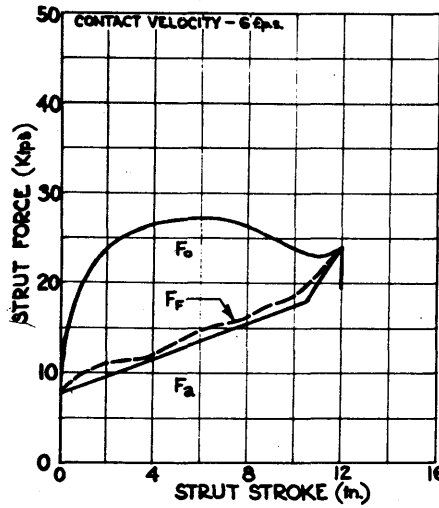

Figure 11 - Composition of Shock Strut Force
1000 RPM Wheel Speed
Nose Down Attitude
29,500 Lb. Test Weight
(Computer Data)

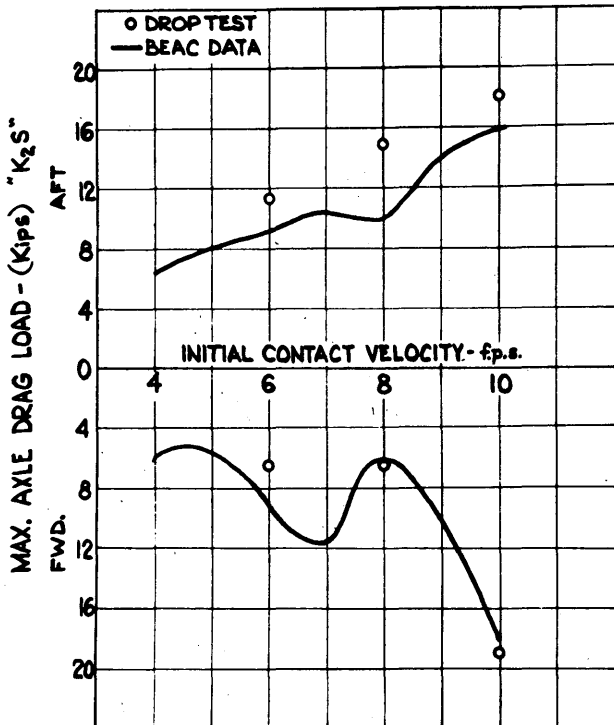

Figure 12

Maximum Axle Drag Load Versus Contact Velocity
1000 RPM Wheel Speed
2/3 Wing Lift
29,500 Lb. Weight
Nose Down Attitude

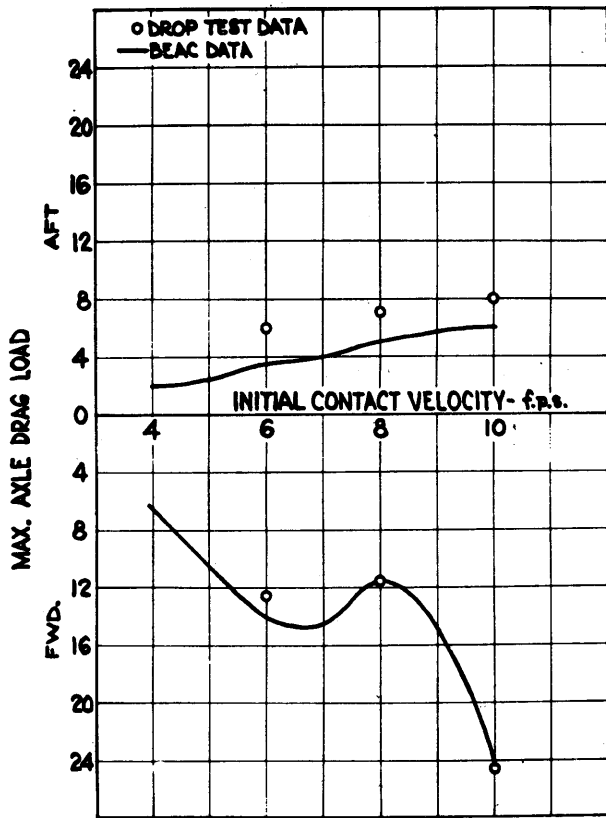

Figure 13

Maximum Axle Drag Load versus Contact Velocity
 1000 RPM Wheel Speed
 2/3 Wing Lift
 29,500 Lb. Weight
 Nose Up Attitude

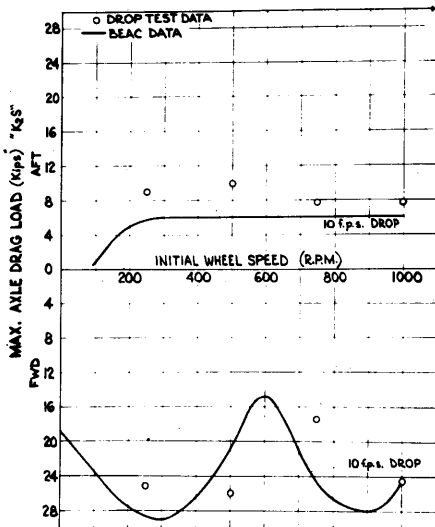

Figure 15 - Maximum Axle Drag Load versus Wheel Speed
 2/3 Wing Lift
 29,500 Lb. Weight
 Nose Up Attitude

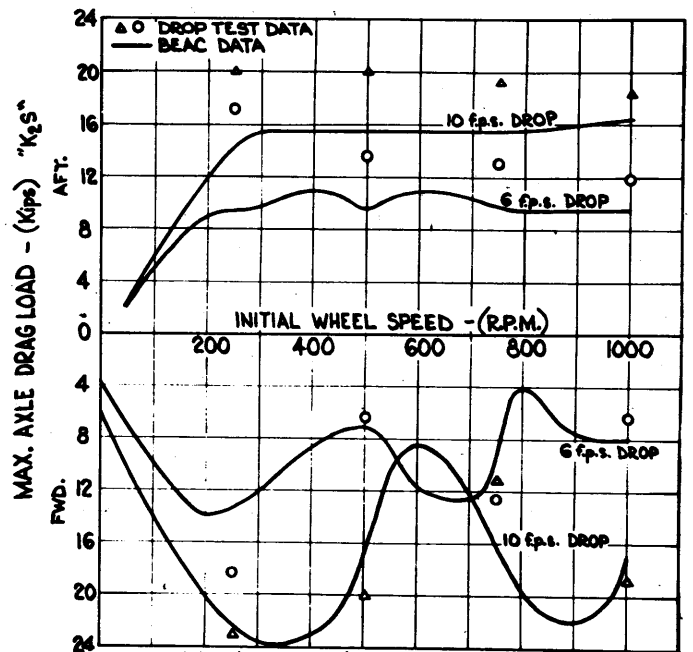

Figure 14 - Maximum Axle Drag Load versus Wheel Speed
 2/3 Wing Life
 29,500 Lb. Test Weight
 Nose Down Attitude

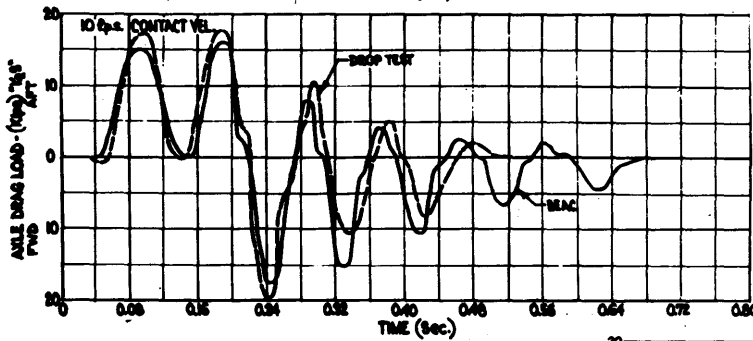
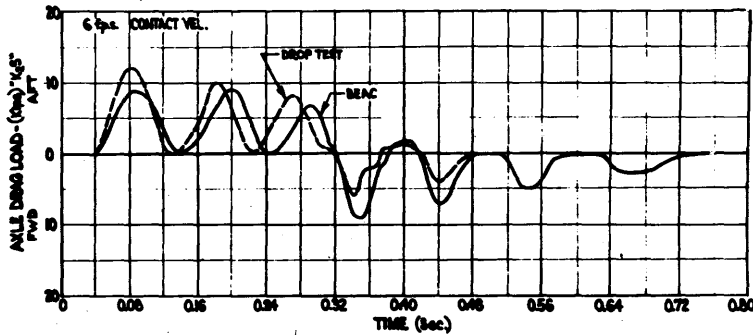
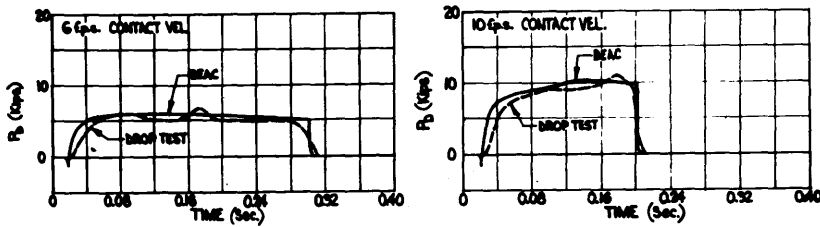

Fig. 16
Applied and Resultant Axle Drag
Load vs. Time.
1000 RPM Wheel Speed
29,500 Lb. Test Weight
Nose Down Attitude.

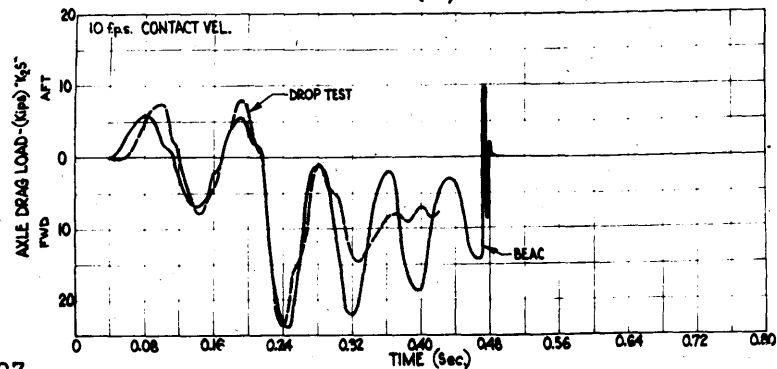
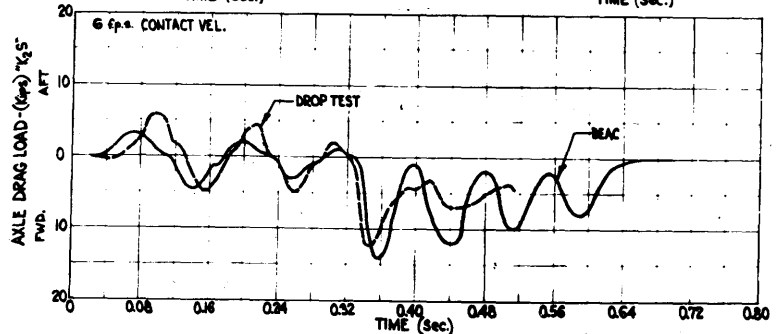
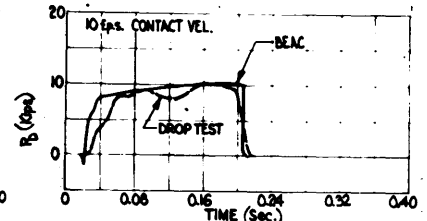
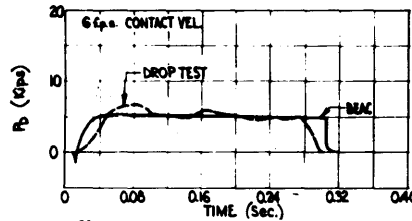

Fig. 17
Applied and Resultant Axle Drag
Load vs. Time
1000 RPM Wheel Speed
29,500 Lb. Test Weight
Nose Up Attitudes

THE EQUIVALENT CIRCUITS OF SHELLS

USED IN AIRFRAME CONSTRUCTION

R. H. MacNeal
California Institute of Technology
Pasadena, California

Introduction

In discussing elastic shells one must be careful to state clearly the type of shell being discussed. Although a complete description together with restrictive assumptions will be given later, it is well to state at the outset that the type of shell discussed in this paper is the type to be found in aircraft fuselage construction. Such a shell has an elongated shape and consists of a thin skin supported by rings and longitudinal members. In analyzing such shells it is the universal practice to replace the elastic supporting rings by rigid bulkheads in order to simplify the analysis. This assumption will not be made in this paper.

The means of analysis to be used in this paper is an electric analog computer of the "direct analogy" type. Any complicated system, if it is to be analyzed on such a computer, must have its equations formulated in a very special way. Essentially one seeks for laws of equivalence between the system being analyzed and a lumped constant electrical network. The basic laws of equivalence between the equations of elasticity and the equations of an electrical circuit are well known. In fact there are two alternative sets of laws depending on whether force is made analogous to current or to voltage. If the former alternative is chosen the laws of equivalence are: force is analogous to current; displacement is analogous to voltage; Hooke's Law is analogous to Ohm's Law; equations of equilibrium are analogous to Kirchhoff's Law for the sum of currents entering a node; and the equations concerning the compatibility of strains are analogous to Kirchhoff's Law for the voltages around a loop.

However much comfort these basic laws of equivalence may give they are usually insufficient to determine the form of a lumped constant electrical network that is analogous to a given structure. For one thing elastic structures are continuous rather than "lumped", and some means must be found for replacing the given continuous elastic structure by an idealized lumped one before an electrical analogy can be found. This "lumping" consists either of replacing the differential equations governing the structure by finite-difference equations, or of employing other devices such as concentrating normal stress carrying area into equivalent flanges and shear carrying area into equivalent panels. In the analysis of stiffened structures this latter approach is reinforced by the fact that much of the structure is in fact so concentrated. In this paper both of the methods mentioned will be used.

In deriving an electrical analogy for an elastic structure an effort should be made to preserve a one-to-one correspondence between the properties of the electrical circuit and the properties of the idealized structure. This correspondence means, for example, that the current in resistor A is equal to the force in flange A' multiplied by a scale factor, or that the voltage at node B is equal to the vertical displacement at panel point B' multiplied by a scale

factor. If such correspondences are preserved, the analog computer can be made a useful tool for designing as well as for analyzing structures. If a change in the cross-sectional area of a single flange corresponds to changing the value of a single resistor and if currents can be easily and directly converted into internal forces, then design changes can be made very rapidly and their effects instantly determined while the problem is set up on the analog computer. In all of the work done with the Caltech analog computer¹, such one-to-one correspondences have been closely preserved. In the present paper they are preserved to the last detail.

Another advantage of the close one-to-one correspondence of the electrical analogy and the idealized structure is that it enables the structural engineer, who is usually un instructed in electric circuit theory, to understand the operation of the analog computer, and to use it himself after a period of indoctrination. It has even been found that structural engineers may be aided in their understanding of structures by using some of the concepts of electric circuit theory. This naturally applies, a fortiori, to the electrical engineer.

It is the hope of the staff of the Caltech analog computer (The Analysis Laboratory) to develop a method that is generally applicable to the solution of aircraft structures. This paper is but one step toward this goal. At present, analogies exist in the technical literature for beams, frameworks, flat sheets, the bending of plates, and the bending of plate-like multicell shells. The present paper adds to this list the analysis of rings bending in their own planes and certain types of shells. Structures combining components of the above types can be analyzed by combining their electrical analogies. Consequently it is at present possible to analyze a great many practical aircraft structures.

The size of an analog computer that is capable of adequately analyzing these practical aircraft structures is rather large. It is estimated that such a computer should contain at least one or two hundred transformers and two or three hundred resistors. The Caltech analog computer which has sixty transformers and about ninety resistors is adequate only for problems of moderate complexity.

Some of the previous papers that have a direct bearing on the subject of the present paper should be mentioned.

In 1944 G. Kron published a paper² containing electrical analogies for the general three dimensional elastic field problem, and as sub-cases, analogies for the plane-stress and plane-strain problems. In a companion paper³, G. K. Carter, worked the plane-stress problem for a deep cantilever beam.

More recently analogies have been developed for thin multicell shells having a horizontal plane of symmetry by using an equivalent plate theory⁴.

In 1951 Goran published a paper⁵ containing an electrical analogy for stiffened elastic shells. The shells were assumed to be conical and to be supported by rigid bulkheads. Although the stringers were not assumed to be parallel, the panels were assumed to be nearly rectangular in shape. Goran used the minimum energy principle in deriving the equations from which he developed the electrical analogy, in contrast to the method of difference equations used in this paper. For this reason he was unable to attach a physical significance to some of the terms in his equations.

Derivation of an Analogy for a Circular Non-Cylindrical
Stiffened Shell

A sketch of a circular non-cylindrical shell is shown in Figure 1a. This shell consists of circular elastic rings to which stringers and a thin skin covering are attached. The rings are spaced a finite distance apart in planes perpendicular to the axis of the shell, which is assumed to be straight. The stringers lie in planes perpendicular to the rings and are assumed to carry axial forces only. The skin is divided into panels by the intersection of the stringers and rings; these panels are assumed to carry shearing forces only, the effective normal stress carrying area of the skin having been included in the cross-sectional area of the stringers. The radius of the shell may vary in any manner along the axis of the shell, but the radius of curvature of the stringers is assumed to be large compared to the radius of the shell. The angle between the axis of the stringers and the axis of the shell need not be small provided that the rings and stringers are spaced close enough together so that the shear panels are approximately rectangular in shape.

The stringers and skin will be treated separately from the rings. For the analysis of the stringers and skin it will be shown that the rings can be represented by tangential external forces applied to the skin along the lines of intersection of the skin and the rings.

The equilibrium and force-displacement equations will be derived for the skin and stringers and an electrical circuit satisfying these equations will be constructed. Then in the next section the equations for an elastic ring will be written and a circuit satisfying these equations will be constructed. As a final step the two circuits will be connected together to give the electrical analogy for the whole shell. Orthogonal coordinates in the surface of the shell parallel and perpendicular to the stringers as shown in Figure 1a will be employed in the analysis of the skin and stringers. An enlarged portion of the shell is shown in Figure 1b. This figure shows the points where displacements parallel to the axis of the stringers, u_s , and displacements parallel to the axis of the rings, u_t , are defined.

Figure 2 shows a portion of the skin between two adjacent rings with its midpoint on a stringer. F_s and F_s' are the total axial forces carried by the stringer at points where the stringer passes over two adjacent rings. F_{ts} and F_{ts}' are the total tangential forces acting in the s direction on sections passing through the centers of two adjacent shear panels.

The force in the stringer is continuous at the point where it passes over a ring because of the following assumptions:

- a. The ring can only exert forces which lie in its own plane.
- b. The stringer cannot support bending loads.
- c. The change in direction of the stringer at the point where it passes over a ring is negligibly small compared to the curvature of the ring.

Consequently the ring can only exert forces in the t direction, and these forces can be treated as applied forces in the analysis of the skin and stringers.

In Figure 2, $\alpha/2$ is the angle between the stringer and the line of action of the shear force, F_{ts}' . This angle is approximately equal to $1/2\psi\Delta\phi$ where ψ is the angle between the axis of the shell and the axis of the stringer, and $\Delta\phi$ is equal to the angle subtended by a segment of ring between two adjacent stringers. The cosine of the product of these angles will be assumed to be equal to one. Hence the equilibrium equation for forces in the s direction is:

$$F_s' - F_s + F_{ts}' - F_{ts} = 0 \quad (1)$$

Using difference equation notation, equation 1 can be written

$$\Delta_s F_s + \Delta_t F_{ts} = 0 \quad (2)$$

This notation will be used in the remainder of this paper.

Figure 3 shows a portion of the skin between two stringers with its midpoint on a ring. F_{st} and F_{st}' are the total tangential forces acting in the t direction on sections passing through the centers of two adjacent shear panels. f_t is the tangential force exerted by the ring on the skin per radian of ϕ . The lines of action of the forces F_{ts} and F_{ts}' intersect the axis of the shell, so that the equation of equilibrium for moments about this axis is

$$\Delta_s(r \cdot F_{st}) - r\Delta\phi \cdot f_t = 0 \quad (3)$$

F_{ts} and F_{st} are defined as the total forces acting on perpendicular planes passing through the center of a shear panel. From equation 2 it is seen that the shear stress cannot be uniform in the s direction across the surface of a panel if r is not constant.

It will be assumed that the variation of shear stress is linear across the surface of the panel, so that the value at the center of the panel is equal to the average along a line in either the s or t direction. Then a relationship between F_{ts} and F_{st} may be obtained from the equilibrium equation of a small element at the center of the panel. (See Figure 4.)

$$F_{ts} \cdot \frac{\delta s}{\Delta s} \cdot \delta t = F_{st} \cdot \frac{\delta t}{\Delta t} \cdot \delta s \quad (4)$$

$$F_{ts} = F_{st} \cdot \frac{\Delta s}{\Delta t} \quad (5)$$

The equilibrium of the portion of the shell shown in Figure 3 for forces in a direction parallel to t at the center of the section may be demonstrated, if desired, by means of equations 3 and 5.

The force displacement equation for the stringers is quite easily written. The axial displacement of the stringer, u_s , is defined at the midpoints between adjacent rings as shown in Figure 1b while the axial force (positive for tension) is defined at points where the stringer passes over the rings as shown in Figure 2. Assuming the variation in axial force to be linear between adjacent points where u_s is defined, we have, from Hooke's Law:

$$F_s = \frac{EA}{\Delta_s} \left[\Delta_s u_s \right] \quad (6)$$

where A_s is the cross-sectional area of the stringer.

The relationship between shear stress and shear strain for the shear panels is less easily written because the relationship between shear strain and the displacements is complicated. The displacements in the s and t directions are defined at the midpoints of the sides of the shear panel as shown in Figure 1b. The shear strain of the panel is defined as the distortion of the angle between two lines passing through the midpoints of the sides. In computing this angle care must be taken to eliminate apparent distortion due to rigid body rotation about the axis of the shell. From Figure 5, the shear strain,

$$\gamma = \gamma_1 + \gamma_2 \quad (7)$$

where

$$\gamma_1 = \frac{\Delta_t u_s}{\Delta t} \quad (8)$$

$$\gamma_2 = \frac{\Delta_s u_t}{\Delta s} - \delta \quad (9)$$

δ is the angle by which the direction of the s axis, drawn through the center of the panel, has been changed due to translation parallel to the t axis. For small displacements this angle is

$$\delta = \frac{u_t}{r} \cdot \sin \psi \quad (10)$$

where ψ is the angle between axis of the shell and the s axis. From Figure 2 it can be seen that

$$\frac{\partial r}{\partial s} = \sin \psi \quad (11)$$

Combining equations 9, 10, and 11 we find

$$\gamma_2 = \frac{\Delta_s u_t}{\Delta s} - \frac{u_t}{r} \frac{\partial r}{\partial s} \quad (12)$$

Assume that the first term on the right can be replaced by the equivalent partial derivative evaluated at the center of the panel

$$\gamma_2 = \frac{\partial u_t}{\partial s} - \frac{u_t}{r} \frac{\partial r}{\partial s} = r \frac{\partial}{\partial s} \left(\frac{u_t}{r} \right) \quad (13)$$

Replace this equation by its finite difference equivalent and obtain from equation 7

$$\gamma = \frac{\Delta_t(u_s)}{\Delta t} + \frac{r}{\Delta s} \Delta_s \left(\frac{u_t}{r} \right) \quad (14)$$

The shearing strain is related to the total tangential force acting on a line parallel to t by the following equation

$$\gamma = \frac{1}{Gh} \cdot \frac{F_{ts}}{\Delta s} \quad (15)$$

where h is the thickness of the skin. Hence the force displacement equation for the panel is

$$F_{ts} = Gh \frac{\Delta s}{\Delta t} \left[\Delta_t(u_s) + \frac{r\Delta t}{\Delta s} \Delta_s \left(\frac{u_t}{r} \right) \right] \quad (16)$$

The equations that are essential for the construction of an electrical analogy are summarized below.

Equilibrium Equations

$$\Delta_s F_s + \Delta_t F_{ts} = 0 \quad (17a)$$

$$\Delta_s (rF_{st}) - \Delta_t f_t = 0 \quad (17b)$$

$$F_{ts} = F_{st} \cdot \frac{\Delta s}{\Delta t} \quad (17c)$$

Force-Displacement Equations

$$F_s = \frac{EA_s}{\Delta s} \cdot \left[\Delta_s u_s \right] \quad (17d)$$

$$F_{ts} = Gh \frac{\Delta s}{\Delta t} \left[\Delta_t(u_s) + \frac{r\Delta t}{\Delta s} \Delta_s \left(\frac{u_t}{r} \right) \right] \quad (17e)$$

These equations have been derived by assuming the normal-stress carrying area of the shell to be concentrated in stringers. They can also be derived from the known equations for a membrane shell of revolution⁶ by replacing differential operators by finite difference operators.

In the electrical analogy forces are analogous to currents and displacements are analogous to voltages. The complete circuit is shown in Figure 6. This circuit consists of two separate parts. In one part the voltages to ground are the displacements, u_s , while in the other part the voltages to ground are the displacements, u_t . The two circuits are coupled together by means of ideal transformers. Transformer coils which are coupled together are indicated by circled numbers. Points at which each one of the above equations are satisfied are indicated by letters in the circuit. Equation 17a is satisfied by the currents entering a node of the u_s circuit. Equation 17b is satisfied by the currents entering a node of the u_t circuit. Equation 17c is satisfied by the currents flowing in the windings of a transformer whose turns ratio is $r\Delta t/\Delta s$. Equation 17d is satisfied by a resistor whose value in ohms is $\Delta s/EA_s$. In equation 17e the increment in u_s in the t direction is added to a fraction of the increment in u_t/r in the s direction. This addition is accomplished by the

same transformer which satisfies equation 17c. The sum of these terms is the voltage across a resistor whose value is $\Delta t/Gh\Delta s$ and through which a current equal to F_{ts} flows.

Two observations can be made concerning equations 17 and the resulting circuit. If r does not depend on s the equations are those of a cylindrical shell, and r may be removed from inside the difference operators. Hence the equations of a non-cylindrical shell have the same form as the equations of a cylindrical shell if rotation about the axis, u_t/r , (rather than tangential displacement) and torque about the axis, rF_{st} , (rather than tangential force) are used as variables. The rotation and torque about the axis are the natural variables to use in deriving the equations of a circular non-cylindrical shell.

Equations 17 also apply with slight modification to the skin and stringers of a non-circular cylindrical shell. In this case r depends on t rather than on s , but this dependency on t will not enter into the derivation of the equations for the skin and stringers. Hence for a non-circular cylindrical shell, r can be eliminated from equation 17e; and can be divided out of equation 17b to give

$$\Delta_s(F_{st}) - \Delta\phi \cdot f_t = 0 \quad (18)$$

Since f_t is the external tangential force per radian of ϕ , $\Delta\phi \cdot f_t$ is the total external tangential force per bay in the t direction.

In Figure 6 parts of the u_t circuit corresponding to different values of ϕ are not shown connected. The interconnection is accomplished by means of the currents $\Delta t f_t$ which are the reactions of the rings. The voltages at the points where these currents are inserted are constrained to be equal to the corresponding values of u_t/r for the rings. A complete circuit for a shell, including the circuits for elastic rings will be shown later. If the rings are assumed to be rigid, the circuits for the rings become quite simple as will be shown.

Derivation of an Analogy for an Elastic Ring

An electrical analogy for the bending of a ring in its own plane will be derived in this section. In the discussion of shells supported by rings it is usually assumed that the rings are perfectly free to warp out of their own planes. An electrical analogy for a circular ring deforming perpendicular to its own plane has been derived by Russell⁷, but this effect will not be considered here.

It will also be assumed that the effects of shearing stiffness and axial stiffness of the ring are small so that these effects can be ignored. This assumption is made in order to simplify the discussion; these effects can be included in the electrical analogy if desired.

An element of ring is shown in Figure 7. The displacement quantities to be used in the analysis of the ring are the normal and tangential displacement of the center line and the rotation of the normal to the center line. The independent position variable, ϕ , is the angle between a horizontal line and

the normal to the center line of the unloaded ring. f_t and f_n are external tangential and normal loads per radian of ϕ applied along the center line of the ring. Distributed moment loads will not be considered. It will be noted in Figure 7 that the radius of curvature is not constant.

The loads, internal forces and displacements of the above described ring satisfy the following six first-order differential equations:

Equilibrium

$$\frac{dF_n}{d\phi} = F_t - f_n \quad (19)$$

$$\frac{dF_t}{d\phi} = -F_n - f_t \quad (20)$$

$$\frac{dM}{d\phi} = -F_n \cdot r \quad (21)$$

Stress-strain and strain-displacement

$$\frac{d\theta}{d\phi} = \frac{Mr}{EI} \quad (22)$$

$$\frac{du_t}{d\phi} = -u_n \quad (23)$$

$$\frac{du_n}{d\phi} = u_t + \theta \cdot r \quad (24)$$

These equations will be replaced by the corresponding first order difference equations. In so doing central difference equations will be used so that the quantities appearing behind the derivative symbols in the above equations are defined at values of ϕ midway between the values of ϕ at which the undifferential quantities are defined. For example equation 19 may be approximated by the following equation

$$(F_n)_2 - (F_n)_0 = \left[(F_t)_1 - (f_n)_1 \right] \cdot \Delta\phi \quad (25)$$

The same difference equation notation can be used for this equation as was used in the previous section

$$\Delta\phi F_n = F_t \Delta\phi - f_n \Delta\phi \quad (26)$$

Position subscripts are not required in this equation. u_n , F_t and M are defined at the same points and these points are midway between the points where θ , u_t and F_n are defined.

Equations 20 to 24 could be replaced by simple difference equations in the same manner that equation 19 was replaced by equation 26. However it can be demonstrated that the following difference equations are more accurate. They give exactly correct results for a segment of ring which is rigid, has constant radius of curvature, and which is uniformly loaded. In other words for any ring with constant radius of curvature, they give correct results for rigid body displacements and the statically determinant parts of the internal forces. These statements require lengthy proofs and instead they will be partially demonstrated later by means of an example

Equilibrium:

$$\Delta\phi F_n = (F_t - f_n) \cdot 2 \sin \frac{\Delta\phi}{2} \quad (27)$$

$$\Delta\phi F_t = - (F_n + f_t) 2 \sin \frac{\Delta\phi}{2} \quad (28)$$

$$\Delta\phi M = - F_n (2r \sin \frac{\Delta\phi}{2}) \quad (29)$$

Stress-strain and strain-displacement

$$\Delta\phi \theta = \frac{r\Delta\phi}{EI} \cdot M \quad (30)$$

$$\Delta\phi u_n = (u_t + r \theta) \cdot 2 \sin \frac{\Delta\phi}{2} \quad (31)$$

$$\Delta\phi u_t = - u_n \cdot 2 \sin \frac{\Delta\phi}{2} \quad (32)$$

For $\Delta\phi$ small, $2 \sin \Delta\phi/2$ is approximately equal to $\Delta\phi$ and the above equations approach the corresponding simple central-difference equations.

An electrical circuit which identically satisfies the above equations is shown in Figure 8. In this circuit displacement quantities are voltages to ground and the loads and internal forces are currents. Equation 29 is satisfied by the currents entering a junction in the upper circuit of Figure 8. Equations 27 and 28 are similarly satisfied by the currents in the middle and lower circuits of Figure 8. Ideal transformers are used to produce currents flowing into the junctions of one circuit that are proportional to the currents flowing in the "main line" of another circuit.

Equation 30 expresses Ohms law for the drop in voltage between successive nodes of the upper circuit. Equation 31 is satisfied in the "main" line of the middle circuit by means of ideal transformer coils which insert voltages in the line proportional to the voltages to ground in the other two circuits. Equation 32 is similarly satisfied in the lower circuit. Each transformer is instrumental in the satisfaction of two equations, an equilibrium equation and a strain-displacement equation. The circuit of Figure 8 employs three transformers per cell. If the radius of curvature of the ring is constant, or if the ring can be divided into segments containing several cells for each of which the radius of curvature is constant, a circuit requiring only two transformers per cell can be used. Since r is now assumed to be constant, equations 27 to 32 can be rewritten as follows, (where $2 \sin \Delta\phi/2$ has been abbreviated by $\Delta\phi'$).

$$\Delta\phi F_n = (F_t \cdot r) \cdot \frac{\Delta\phi'}{r} - f_n \cdot \Delta\phi' \quad (27a)$$

$$\Delta\phi (F_t \cdot r) = -F_n (r\Delta\phi') + (f_t \cdot r) \Delta\phi' \quad (28a)$$

$$\Delta\phi M = -F_n (r\Delta\phi') \quad (29a)$$

$$\Delta\phi \theta = \frac{r\Delta\phi'}{EI} \cdot M \quad (30a)$$

$$\Delta\phi u_n = \left\{ \frac{u_t}{r} - (-\theta) \right\} r\Delta\phi' \quad (31a)$$

$$\Delta\phi \left(\frac{u_t}{r} \right) = -u_n \cdot \left(\frac{\Delta\phi'}{r} \right) \quad (32a)$$

In this form of the equations u_t/r and $F_t \cdot r$ replace u_t and F_t as variables as in the case of the skin and stringers for a non-cylindrical shell. The purpose of this manipulation has been to get equation 31a into the form shown, where the increment in u_n is proportional to the difference of the other two displacement quantities. This equation can be satisfied by a single transformer whereas equation 31 required two transformers. A circuit satisfying equations 27a to 32a is shown in Figure 9b. In this figure the transformer coils connecting the upper and middle circuits are coupled to the transformer coils in the main line of the lower circuit. This remote coupling is indicated by circled numbers. The currents corresponding to the loads are not shown in this circuit.

Circuits for Rigid Rings

It is frequently possible to assume that some or all of the rings supporting a shell are rigid in their own planes without serious error in the analysis of the shell. This assumption greatly simplifies analytical solutions of shell problems and sometimes eliminates a great deal of the equipment required in an analog computer solution. Since only the tangential displacement of the ring is important in the analysis of shells, only this coordinate need be represented at points around the periphery of a rigid ring.

The position of a rigid bulkhead is determined by the displacement of one of its points in two perpendicular directions and by the rotation about an axis perpendicular to its plane (as shown in Figure 10a). The tangential displacement at points on the periphery can be computed from these three quantities.

$$u_t = Y \sin \phi + Z \cos \phi - \Theta r \sin \alpha \quad (33)$$

In an analytical solution Y , Z and Θ are unknown quantities. They are usually regarded as Lagrangian multipliers and equation (33) is regarded as an equation of constraint. In an electrical analogy this equation of constraint can be satisfied by a network of transformers, a general form of which is shown in Figure 10b. This network also satisfies the equilibrium equations of the rigid ring. Applied loads in the y and z directions and applied torque are inserted as currents into the network as shown. Since, in general, this circuit requires three transformers for each tangential displacement it has, in general, no advantage over an elastic ring circuit in which the resistors corresponding to the bending stiffness of the ring are set equal to zero. However in practice, one or more of the terms in equation (33) may be equal to zero because either the unknown or the coefficient may vanish. In such cases the transformer network may be quite simple

For example, in a shell with a vertical plane of symmetry, loaded symmetrically with respect to this plane;

$$u_t = Z \cos \phi \quad (34)$$

This equation requires one transformer for each value of u_t . It is possible to introduce further simplification by replacing u_t by a variable which depends on ϕ . Let

$$u_t = \bar{u}_t \cos \phi \quad (35)$$

then

$$\bar{u}_t = Z \quad (36)$$

If this change of variable is now introduced into the equations of the skin and stringers (equation 17), it will be found that the form of the equations will remain unchanged and that the only effect will be a change in the turns ratio of the transformers coupling the u_s and u_t circuits. Equation (36) is then satisfied by connecting together all the tangential displacement nodes in any one ring.

As another example consider a rigid ring (or bulkhead) which is very thin in one direction (see Figure 10a). In this case it may be assumed that the angle between the y axis and the top and bottom surfaces of the shell is small everywhere except at the ends, where there are closing vertical segments. Furthermore it is usual to assume that Y, the displacement parallel to the long direction, is zero. In this case

$$\begin{aligned}
 u_t &= -\theta \cdot r \sin \alpha && \text{top and bottom surfaces} \\
 u_{t1} &= Z - \theta \cdot c/2 && \text{at the left end} \\
 u_{t2} &= -Z - \theta \cdot c/2 && \text{at the right end}
 \end{aligned}
 \tag{37}$$

Here again scale factors can be introduced to simplify the equations

$$\begin{aligned}
 \bar{u}_t &= -\frac{u_t}{r \sin \alpha} = \theta && \text{top and bottom surfaces} \\
 \bar{u}_{t1} &= u_{t1} = Z - \theta \cdot c/2 && \text{at left end} \\
 u_{t2} &= -u_{t2} = Z + \theta \cdot c/2 && \text{at right end}
 \end{aligned}
 \tag{38}$$

These equations are satisfied by the simple network of Figure 10b.

With this circuit for a rigid bulkhead and the circuit for the stringers and spars (Figure 6), two spar box wings with unsymmetrical top or bottom surfaces can be analyzed. The extension to multispar wings is simple and direct.

Solution of Problems

The Caltech analog computer was used for the solution of two problems in connection with the preparation of this paper. This computer consists essentially of a storehouse of electrical parts which contains, among other things, the resistors and high quality transformers required in the solution of stress analysis problems.

The first problem was the analysis of the simple circular ring shown in Figure 9a subjected to two opposing concentrated vertical loads. Because of the symmetry of the ring and its loads a quadrant of the ring can be substituted for the whole if proper boundary conditions are applied at the ends of the quadrant. At $\phi = 0$ the proper boundary conditions are that θ , u_t and F_n equal zero. At $\phi = \pi/2$ the proper boundary conditions are that θ and u_t equal zero and that F_n equals P, one-half of the applied load.

In Figure 9b, the quadrant of ring has been represented by a circuit containing four cells. The boundary conditions have been satisfied by setting the corresponding electrical quantities equal to zero at the two ends.

The results of the analysis are presented in Table I in dimensionless form. An exact analysis of the problem using differential equations is compared with the analog computer solution. In addition an exact solution of the difference equations governing the electric circuit is shown. It will be seen that the differential equation solution and the exact solution of the difference equations give identical results for the internal shear and internal axial force. This was to be expected since these quantities are statically determinate in the problem investigated. The other quantities show errors due to finite difference approximation. A comparison of the difference equation solution and the analog computer solution shows errors in the computer solution of the order of one or two percent, which is fairly typical of the results customarily obtained with the Caltech analog computer.

The second problem was the analysis of a conical shell supported by circular elastic rings. As such it provides an example illustrating the manner in which the shell and ring circuits are interconnected. The structure, which has three elastic rings and fourteen stringers, is shown in Figure 12a, and specifications for the structure are given in Table II. This structure is supposed to resemble the aft portion of an aircraft fuselage. The relative size of the stringers and rings and the thickness of the skin have been chosen to give maximum stresses of the same order of magnitude in the stringers, skin and rings. The structural weight is divided approximately equally among these three components. The number of stringers and the number of rings in the structure are much fewer than the number that would be employed in an aircraft fuselage, so that each stringer of the structure represents several stringers in the fuselage, and the stiffness of intermediate fuselage rings is included in the stiffness of the three main rings shown. It will seldom if ever be possible to represent in detail on an analog computer all of the members in a large elastic structure.

The shell is subjected to symmetrical concentrated vertical loads applied to the ring at the small end of the shell and these loads are reacted at the large end, which is built into a rigid wall. Because of the symmetry of the structure and the applied loads, only a quarter of the shell need be considered if appropriate boundary conditions are applied. This part of the shell has been given a two coordinate numbering system for the identification of points in the structure. For example, point 42 refers to a point at the intersection of ring number 4 and stringer number 2.

The electrical analogy for the structure is also shown in Figure 12. This circuit consists of three parts, the u_s and u_t circuits discussed in section II and the ring circuits discussed in section III. In Figure 12b only one ring circuit is shown since the other two have an identical appearance. The connection between the ring circuit shown and the u_t circuit are indicated by the circled letters a, b, and c. Currents corresponding to the interaction forces between the skin and the rings flow through these connections. In Figure 12a a cutout is indicated in the middle bay. Electrical parts corresponding to the cutout, (shown dotted in Figures 12c and 12d) are removed when the cut panel is removed.

The boundary conditions at the vertical plane of symmetry are that the shear stresses in shear panels intersected by this plane are zero; and that in the ring circuits θ , u_t and F_n are all zero except when vertical loads are applied to the ring in the plane of symmetry, in which case F_n is equal to P , one-half of the applied load. The boundary conditions at the horizontal plane of symmetry are that the displacement in the s direction, u_s , is zero; and that in the ring circuits, u_n , M and F_t are zero except when vertical loads are applied

to the ring in the horizontal plane of symmetry, in which case F_t is equal to $-P$. The boundary conditions at the large end of the shell are that both u_s and u_t are equal to zero. At the small end the boundary conditions are conveniently expressed as the absence of applied loads except as indicated. All of the above boundary conditions have been satisfied in the electrical circuit by means of short and open circuits. Short circuits are used to set displacements equal to zero while open circuits are used to set internal forces equal to zero.

The electrical circuits shown in Figure 12 use 27 resistors and 27 transformers which is approximately 40% of the present capacity of the Caltech analog computer. In calculating the values of the transformer turns ratios and resistors to be used in the circuit it is necessary to make use of scale factors. This aspect of the problem has been omitted in the present discussion in order that the electrical quantities shown in the circuit diagram may have a direct significance in terms of mechanical quantities. A brief discussion of the scale factor methods employed with the Caltech analog computer is given in the appendix of reference 8.

The structural and loading conditions that were investigated in this problem are tabulated in Table II. It was desired to investigate the effect of the following things on the distribution of internal forces; the effect of the stiffness of the rings; the effect of the location of the vertical load on the end rings; and the effect of a cutout in the middle bay.

The results of these investigation are given in Tables III and IV. The quantities recorded according to the numbering system previously discussed are: the stringer forces, F_s ; the panel shears, F_{ts} ; the ring bending moments, M ; and the vertical displacements. The vertical displacements have been obtained by vectorially combining the tangential and normal displacements of the rings. The tabulated results are subject to experimental errors and when four significant figures are given, the fourth figure is entirely unreliable.

The main conclusion to be drawn from these results is that the stiffness of the rings has a rather small effect on the distribution of internal forces. The only change made between conditions (1) and (2) was that in condition (2) the rings were made five times as stiff as in condition (1). It will be seen that the stiffness of the rings has very little effect on the internal forces except between the second and third rings. However the distortion of the third ring in condition (1), as given by the vertical displacements, is quite large. In another condition, the results of which are not tabulated, the first and second rings were stiffened by a factor of ten while the third ring retained its normal stiffness. The difference in the results between this condition and condition (1) were negligible.

The results of condition (3) indicate that the effect of ring stiffness is considerably less when the applied vertical loads are in a horizontal plane than when they are in a vertical plane. The results of conditions (4) and (5) indicate that even moderately small symmetrical cutouts produce a severe redistribution of the internal forces and that, in this case, the effect of ring stiffness is important if accurate results are desired.

SYMBOLS

A_s	cross-sectional area of stringer	
E	Young's modulus	
f_n	external load normal to ring per radian of ϕ	
f_t	external load tangential to ring (or skin) per radian of ϕ	
F_n	shear force in ring	
F_s	force in stringer	
F_{st}	tangential force in panel parallel to t	
F_t	axial force in ring	
F_{ts}	tangential force in panel parallel to s	
G	shear modulus	
h	thickness of skin	
I	moment of inertia of ring cross-section	
M	bending moment in ring	
P	applied vertical load	
r	radius of circular shell; radius of curvature of ring; distance to point in rigid ring	
s	coordinate parallel to stringer	
t	coordinate perpendicular to stringer and parallel to ring	
u_n	displacement normal to axis of ring	
u_s	displacement parallel to s	
u_t	displacement parallel to t	
\bar{u}_t	coordinate related to u_t by transformation	
Y	horizontal displacement of rigid bulkhead	
Z	vertical displacement of rigid bulkhead	
α	angle between two adjacent stringers; angle between tangential displacement and line to a point in a rigid bulkhead.	
γ	shear strain of panel	
δ	angle by which direction of s axis is changed due to translation in t direction	
$\left. \begin{array}{l} \Delta_s \\ \Delta_t \\ \Delta\phi \end{array} \right\}$	difference operators in s , t and ϕ directions	
$\left. \begin{array}{l} \Delta_s \\ \Delta_t \\ \Delta\phi \end{array} \right\}$		increments in s , t and ϕ
$\Delta\phi'$		
ϕ	angle between horizontal line and normal to center line of undisplaced ring	
ψ	angle between stringer and axis of shell	
θ	rotation about axis of shell, usually in ring	

BIBLIOGRAPHY

1. McCann, G. D., The California Institute of Technology Electric Analog Computer., Math. Tables and O.A.C., Vol. III, No. 28, pp 510-513, October 1949.
2. Kron, G., Equivalent Circuits of the Elastic Field., J. Applied Mech., Vol. 66, pp A-149-A-161, September 1944.
3. Carter, G. K., Numerical and Network Analyzer Solution of the Equivalent Circuits for the Elastic Field, J. Applied Mech., Vol. 66, pp A-162-A-167, September 1944.
4. Bescoter, S. U. and MacNeal, R. H., Equivalent Plate Theory for a Straight Multicell Wing, NACA TN 2786, September 1952.
5. Goren, L. A., A Minimum Energy Solution and an Electrical Analogy for the Stress Distribution in Stiffened Shells., J. Aero. Sci., Vol. 18, No. 6, pp 407-416, June 1951.
6. Timoshenko, S., Theory of Plates and Shells, McGraw-Hill Book Co., Inc., New York, 1940, p. 373.
7. Russell, W. T., Lumped Parameter Analogies for Continuous Mechanical Systems, Ph.D. Thesis, California Institute of Technology, 1950.
8. MacNeal, R. H., McCann, G. D., and Wilts, C. H., The Solution of Aeroelastic Problems by Means of Electrical Analogies, J. Aero. Sci. Vol. 18, No. 12, pp 777-789, December 1951.

TABLE I

SOLUTION OF CIRCULAR RING PROBLEM

WITH FOUR FINITE DIFFERENCE CELLS PER QUADRANT

Quantity	$\theta(^{\circ})$	Differential Eqns.	Difference Eqns.	Analog Computer
$\frac{F_n}{P}$	22.5	+.3827	+.3827	+.387
	45.0	+.7071	+.7071	+.702
	67.5	+.9239	+.9239	+.922
$\frac{F_t}{P}$	11.25	+.9808	+.9808	+.982
	33.75	+.8315	+.8315	+.824
	56.25	+.5556	+.5556	+.566
	78.75	+.1951	+.1951	+.210
$\frac{M}{PI}$	11.25	+.3442	+.3401	+.340
	33.75	+.1948	+.1907	+.192
	56.25	-.0810	-.0851	-.083
	78.75	-.4415	-.4456	-.447
$\frac{Q}{PI^2/EI}$	22.5	+.1327	+.1335	+.1333
	45.0	+.2071	+.2084	+.2064
	67.5	+.1739	+.1750	+.1703
$\frac{u_t}{PI^2/EI}$	22.5	+.0487	+.0514	+.0515
	45.0	+.0706	+.0747	+.0756
	67.5	+.0515	+.0548	+.0559
$\frac{u_n}{PI^2/EI}$	11.25	-.1271	-.1318	-.1310
	33.75	-.0573	-.0596	-.0586
	56.25	+.0493	+.0509	+.0535
	78.75	+.1349	+.1405	+.1435

TABLE II
SPECIFICATIONS FOR CONICAL SHELL PROBLEM

Number of stringers = 14
 Cross-section area of stringers, $A_s = 0.60 \text{ in.}^2$
 Thickness of skin, $h = .030 \text{ in.}$
 Moment of inertia of rings, $I = 5.33 \text{ in.}^4$
 Young's modulus, $E = 10.4 \times 10^6 \text{ p.s.i.}$
 Shear modulus, $G = 4.0 \times 10^6 \text{ p.s.i.}$

CONDITIONS INVESTIGATED

- (1) Vertical loads applied to points A and A' of end ring (see Figure 12a). No cutouts. Properties of shell as given above.
- (2) Same as (1) except moment of inertia of rings increased by a factor of 5.
- (3) Same as (1) except vertical loads applied to points B and B' (see Figure 12a).
- (4) Same as (1) except with symmetrical cutouts in center bay (see Figure 12a).
- (5) Same as (4) except moment of inertia of rings increased by a factor of 5.

TABLE III
RESULTS FROM STUDY OF CONICAL SHELL

$p = 1 \text{ kip}$

Panel Point	Condition				
	1	2	3	4	5
stringer forces, F_s (kips)					
02	-.945	-.945	-.942	-.330	-.577
04	-1.708	-1.708	-1.708	-1.550	-1.632
06	-2.118	-2.050	-2.124	-2.475	-2.300
22	-.688	-.711	-.722	+.767	+.688
24	-1.282	-1.282	-1.291	-1.409	-1.321
26	-1.612	-1.594	-1.587	-2.124	-2.180
42	-.308	-.380	-.452	-1.783	-1.789
44	-.676	-.714	-.745	-.536	-.650
46	-1.002	-.935	-.882	-.445	-.326
panel shears, F_{ts} (kips)					
11	+1.206	+1.195	+1.191	+1.593	+1.726
13	+.954	+.956	+.963	+.509	+.469
15	+.513	+.531	+.536	+.372	+.155
31	+1.596	+1.550	+1.522	0	0
33	+1.217	+1.231	+1.254	+2.537	+2.457
35	+.618	+.661	+.707	+1.687	+1.838
51	+1.985	+2.046	+2.080	+2.740	+2.789
53	+1.685	+1.662	+1.632	+.994	+1.032
55	+1.013	+.937	+.880	+.449	+.334

TABLE IV
RESULTS FROM STUDY OF CONICAL SHELL
p = 1 kip

Panel Point	Condition				
	1	2	3	4	5
Ring bending moments, M (in-kips)					
22	-0.07	-0.03	+0.02	+3.58	+4.08
24	-0.03	-0.02	+0.01	+0.96	+1.28
26	+0.06	+0.02	-0.02	-2.40	-2.84
42	+0.20	+0.05	-0.08	-3.72	-3.88
44	+0.10	+0.01	-0.02	-1.08	-1.28
46	-0.18	-0.07	+0.06	+2.48	+2.64
62	+4.45	+4.36	-2.28	+5.53	+5.45
64	+3.84	+3.52	-0.56	+4.12	+3.88
66	-5.25	-5.65	+1.44	-5.93	-6.45
Vertical displacements (inches)					
22	.0288	.0283	.0282	.0133	.0247
24	.0290	.0286	.0288	.0262	.0282
26	.0283	.0283	.0283	.0592	.0336
42	.0875	.0871	.0876	.2180	.1887
44	.0880	.0872	.0870	.2105	.1870
46	.0895	.0885	.0880	.1912	.1830
62	.1577	.1670	.1735	.2595	.2515
64	.1660	.1701	.1702	.2660	.2530
66	.1926	.1770	.1627	.3005	.2605

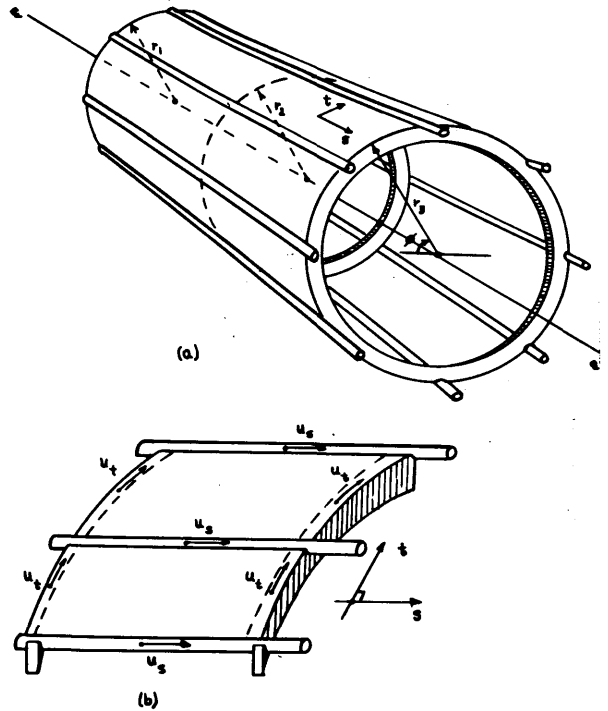

Fig. 1
Circular non-cylindrical stiffened shell.

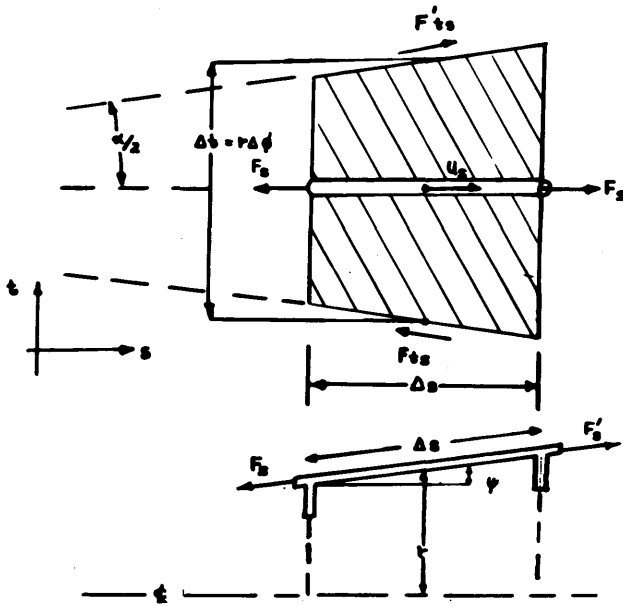

Fig. 2
Equilibrium of portion of shell between two adjacent rings with center on a stringer.

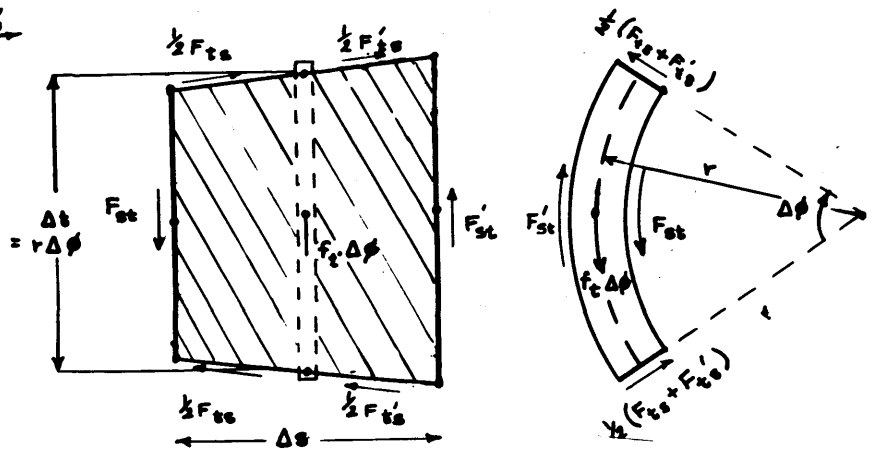

Fig. 3
Equilibrium of portion of shell between two adjacent stringers with center on a ring.

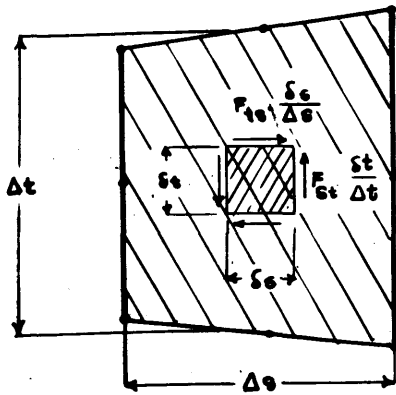

Fig. 4
Equilibrium of shearing forces in a panel.

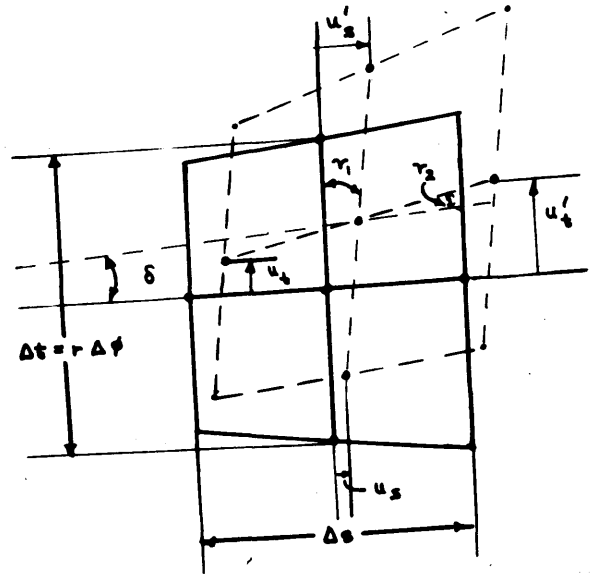

Figure 5 Shear strain of a panel.

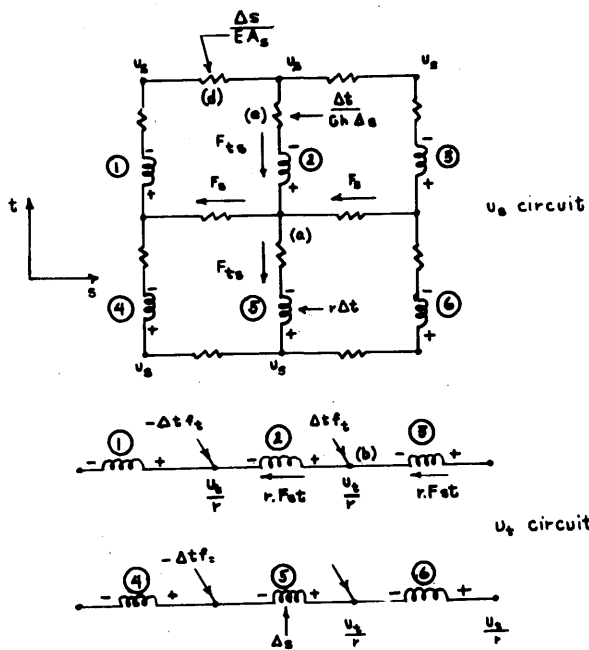

Fig. 6
Electrical analogy for the stringers and skin of a circular non-cylindrical shell.

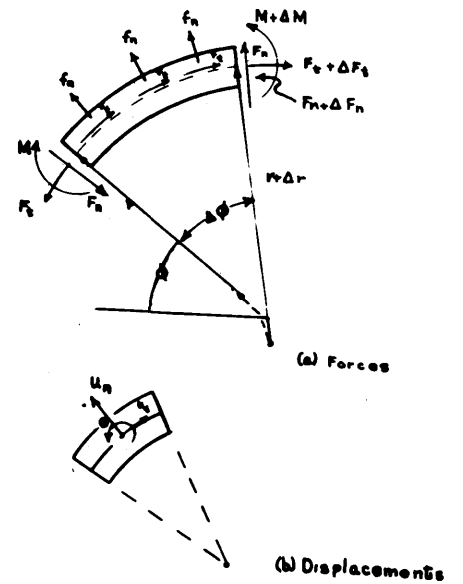

Fig. 7
Segment of a ring showing applied loads, internal forces and displacements.

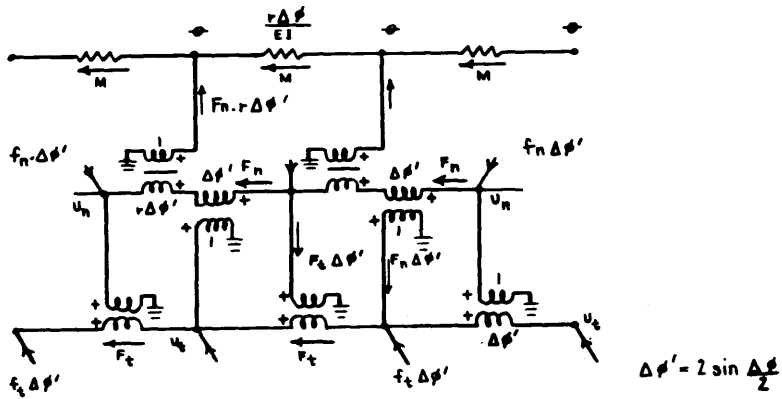
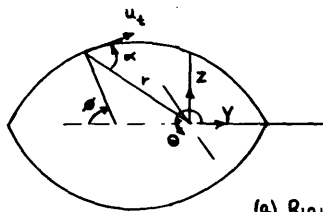
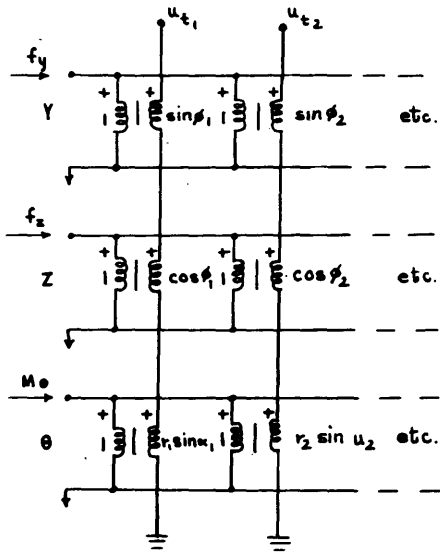

Fig. 8
Electrical analogy for a ring with variable radius of curvature.



(a) Rigid bulkhead
 $u_t = Z \cos \phi + Y \sin \phi - r \sin \phi$



(b) Analogous electric circuit

Fig. 10
Electrical analogy for a rigid bulkhead.

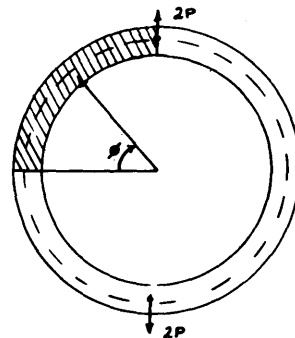

(a) Ring and loads

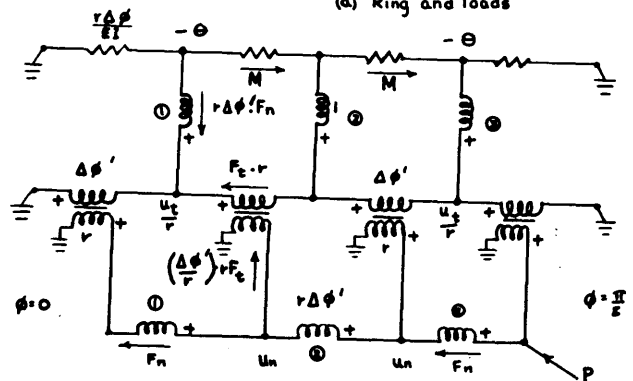

(b) Analog circuit for quadrant of ring

Fig. 9
Electrical analogy for a circular ring subjected to concentrated loads.

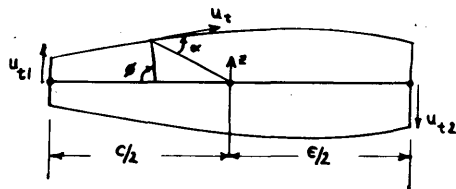

(a) Flat rigid bulkhead

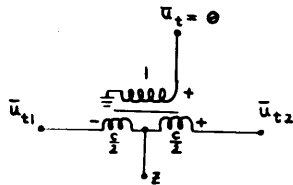

(b) Analog electric circuit

Figure 11 Electrical analogy for a flat rigid bulkhead.

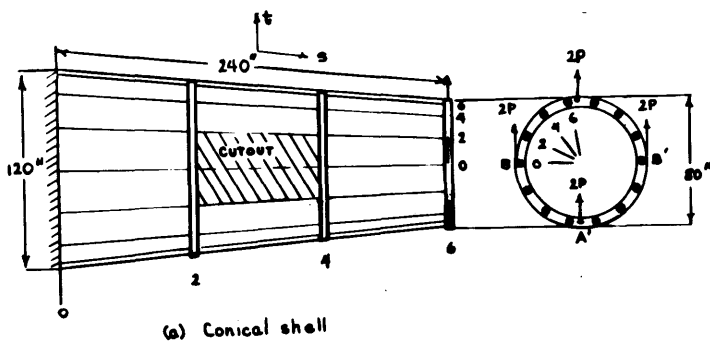

(a) Conical shell

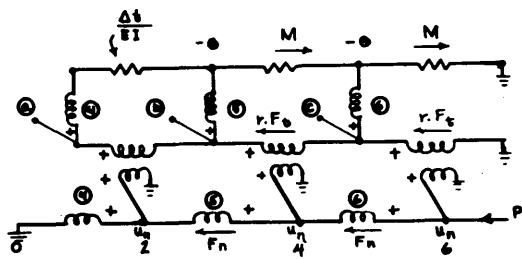

(b) Typical ring circuit
(3 required)

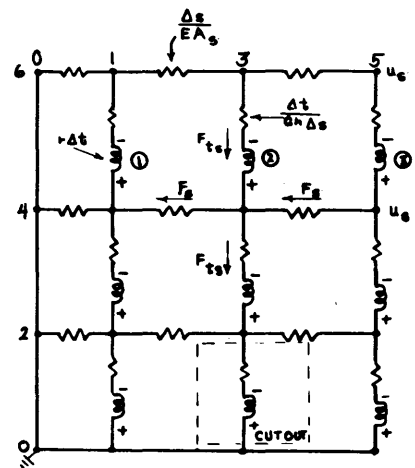

(c) u_e circuit

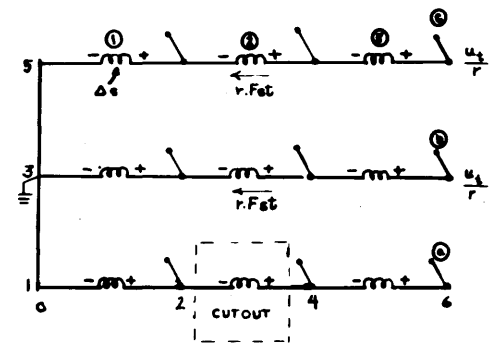

(d) u_t circuit

Figure 12 Electrical analogy for the conical shell problem.

ANALOG-DIGITAL TECHNIQUES IN AUTOPILOT DESIGN

W. T. Hunter and R. L. Johnson
Douglas Aircraft Co., Inc.

Abstract

The analytical and computer techniques employed in the design of aircraft and missile autopilot systems at Douglas Aircraft Company are presented. Roles assigned to digital and analog computation are discussed with the associated reasons for such assignment. The mutual support provided by both types of computation is stressed. Typical examples are used for illustration.

Introduction

One frequently hears discussed, with various degrees of conviction, the relative merits of digital and analog computation. In some fields of endeavor such discussion may be warranted; however, in the design of autopilots at Douglas Aircraft Company, Santa Monica Division, both types have been fitted into design techniques¹. The mutual support of the design problem by both yields results which use of only one type could not do. It is believed that this mutual support has enough application to other design problems that its description as applied to autopilot design may help others in their problems.

Illustration of the points involved is best accomplished through discussion of a specific design problem. The problem selected here is that of automatically controlling a guided missile so that it will respond accurately to lateral acceleration commands from a guidance computer. Target interception may be made under a wide variety of altitude and speed conditions so it is required that the controlled missile operate satisfactorily over a rather wide band of flight conditions. The problem considered here is not that of hardware design but rather the system design leading to hardware specifications.

Preliminary Analytical Preparation

Preliminary analytical work prepares the way for eventual solution of the autopilot design problem. This usually consists of preparation of the system block diagram, description of the component elements by their respective equations relating input and output, derivation of the complete system equations relating missile response to input signals or disturbances and a listing of the system peculiarities or conditions not well described by the preceding

¹ Douglas Aircraft Company has used digital International Business Machine equipment for the last six years, and Reeves Electronic Analog equipment for the last two years, and the Cal. Tech Electrical Analog Computer for four years.

equations. This latter is important in that most of the preliminary analytical work is based upon linear theory and it is important to know the limits involved in order that the effects may be considered in later machine computation.

System Description

Autopilot systems are based upon the use of closed loop or feedback intelligence. In such a system the desired behavior is compared with the actual behavior and any difference, i.e., error, used to drive the system into more exact correspondence. In the sample at hand, this is accomplished by the outer loop of the block diagram shown in Figure 1. The achieved acceleration is compared with the commanded acceleration in the electrical network and, neglecting the other two inputs to the network for the moment, any error taken to the power servo. This servo functions to move the fin in the direction necessary to reduce the measured error. The resulting fin motion imposes forces and moments on the missile causing an incremental change in the lateral (translational) acceleration, the resulting acceleration being measured by the accelerometer for comparison with the commanded acceleration.

The internal rate loop and fin loop feedbacks to the network are required to provide system damping, preventing excessive transient overshoots and oscillations while responding to input commands. The rate loop feedback is accomplished by measuring missile angular rate (about the center of gravity) with a single degree of freedom, spring restrained gyroscope. The fin loop feedback is accomplished by measuring fin actuator travel with a linear potentiometer. All three feedback signals, as well as the input signal, are shaped and summed in the desired manner by the electrical network. The resulting signal which is actually fed to the power servo not only moves the fin in the direction of reducing an acceleration error but provides for moving it in a manner leading to well damped missile motions. The missile structure block in Figure 1 represents measuring instrument pickup caused by structural resonances. Although this pickup contributes nothing to the satisfactory operation of the system, it must be included in the design analysis.

In order to provide a summary of the nomenclature used in the example, the symbols used to represent each individual block are indicated on Figure 1. Specification of each component element by a symbol of the form, F_{oi} , has the meaning:

$$\text{Output} = (F_{oi})(\text{Input})$$

In general, the function F_{oi} is nothing more than the differential equation specifying the component's oi behavior. When this differential equation is linear, the function becomes the common transfer function of the component.

Preliminary Design Phase

This phase of the design is carried out by direct analytical syntheses and by simplified analysis procedures that require no more complex equipment than desk calculators. The system indicated by the block diagram is simplified to the barest essentials. For example, the effects of the missile structure

are neglected completely. The measuring instruments and the power servo are assumed to be ideal components. The frequency characteristics of the electrical network are neglected. In fact, the only dynamics considered are those resulting from forces and moments caused by missile wing deflection and angle of attack.

The important design information obtained in this phase consists of the following:

1. Approximate component gains
2. Measuring instrument ranges
3. Torque and speed requirements of the power servo
4. Desirable aerodynamic characteristics
5. Approximate system performance characteristics

The above information, coupled with engineering experience, is usually sufficient to permit the procurement of hardware, at least for the initial test vehicles.

Frequency Analysis Phase

After the preliminary work has been completed, it is desirable to perform an extensive frequency analysis of the system considering as many of the system characteristics as possible.

The frequency analysis phase is considered to be an extremely important part of any control system design. It furnishes a very clear insight into the manner in which the various components affect the stability and basic response of the system. Virtually all of the design of the electrical shaping network is accomplished through the frequency analysis process. In addition, it is very valuable in tracing down troubles that may be encountered in the flight testing of the design.

This phase of the analysis lends itself well to the use of digital computing equipment because of the large number of routine calculations involved. For the sample problem, the functional operation of each component is represented by a transfer function. If some of the component differential equations are nonlinear, these equations are linearized around certain operating points to permit the derivation of their transfer functions.

The eighteen component transfer functions are represented by expressions of the following form:

$$F_{oi} = \frac{A_0 + A_1P + A_2P^2 + A_3P^3 + A_4P^4 \dots}{B_0 + B_1P + B_2P^2 + B_3P^3 + B_4P^4 \dots}$$

where operator notation has been employed by replacing $\frac{d}{dt}$ with P. The order of the polynomials required to represent the component transfer functions varies from zero for the fin potentiometer (that is $F_{d\delta}$ is independent of P) to as high as ten or more for some of the electrical network transfer functions. The coefficients of the polynomial terms are determined by the differential equation representing the components.

The system equations which are derived from the block diagram yield six transfer functions of the following type:

$$\frac{n_o}{n_i} = \frac{F_{Sc} F_{\delta E} F_{n\delta}}{1 + F_{\delta E} F_{d\delta} F_{Dd} + F_{\delta E} F_{h\theta} F_{Hh} (F_{\theta\delta} + F_{\theta\delta_B}) + F_{\delta E} F_{an} F_{Aa} (F_{n_a\delta} + F_{n\delta_B})}$$

In order to begin the frequency analysis, a trial electrical network is devised (the first trial network is usually one containing only resistors), and the polynomial term coefficients of all of the transfer functions determined from the basic data. Examples of this basic data are wind tunnel test results, resistor and condenser values, instrument natural frequencies and damping ratios, data obtained by experimental measurements on system components, etc. Then each of the component transfer functions are evaluated as complex number functions of frequency². These complex numbers representing the component transfer function are then combined to obtain the products and sums indicated by the system transfer function shown above. The results are then plotted in the form of Nyquist diagrams and system transfer functions. The Nyquist diagram, which indicates the stability of the system, and the system transfer function, which indicates the basic transient response of the system, are then examined for inadequacies. As a result of the knowledge gained in the previous trial, the electrical network or one or more of the component transfer functions are modified and the cycle repeated. An autopilot system that operates over a wide range of aerodynamic conditions (i.e. a number of sets of aerodynamic transfer functions must be considered) may require that the above cycle be repeated several hundred times before a sufficiently optimum design is achieved.

Our digital equipment has been programmed to perform the above transfer function calculations. This has proved very economical when it is considered that the equipment can perform one complete cycle of the above calculation in about 2.5 machine hours as compared to about 100 man hours required for a manually computed solution. Selective storage of parts of the computation reduces the average time per cycle to about 1.25 machine hours. In addition, the machine results are much more dependable than the manually computed results when the problem is this complex.

The ability to perform a complete frequency analysis of a complex system in such a short time becomes a tremendous asset if, as sometimes happens, the test program shows that a design change is required. The change can be completed in a matter of hours instead of weeks, thus greatly expediting flight test schedules.

2 This is accomplished by the well known substitution, $P = j2\pi f$, where $j = \sqrt{-1}$, and f is frequency in cps.

Every attempt is made to eliminate the necessity of processing the data that goes into the machine or the results computed by the machine because it is felt that the machine itself is the most efficient processor. The program for the digital equipment is arranged to use the basic data in the form in which it is most easily available; the results are printed out in the form most easily plotted.

For one complete cycle in the sample problem, the input to the machine consists of approximately 200 numbers. The machine performs some 20,000 operations³ with these numbers, and then prints out slightly more than 1500 numbers for plotting. A survey is presently being made to determine the feasibility of using an automatic plotter for these results. A sample Nyquist diagram and overall transfer function as obtained from digital equipment is shown in Figures 2 and 3.

Analog equipment does not appear to be as well suited as the digital equipment to perform frequency analyses of this type from the standpoint of setup time, running time or accuracy of results. In fact, it is estimated that an analog solution would be more time consuming than the hand solution, because of the difficulty in obtaining the large number of amplitude ratio and phase measurements.

An additional insight into the stability of a system is achieved if the roots of the characteristic⁴ equation can be found. This equation, being of about the 20th order, is difficult to obtain as a polynomial in P and, once obtained, considerable difficulty is encountered in solving for its roots. A digital program to compute, from the same basic data required for the transfer function process, the characteristic equation and its roots has been devised. Setup is not quite complete at this time, but it is estimated that the running time will average 3 hours per solution.

Transient Analysis

Throughout the frequency analysis phase of the design, the transient response of the system must be considered. The transfer function gives a qualitative view of the transient, but at times it is advisable to actually compute the transient response of the linearized system. This can be done conveniently by the following Fourier series process. First, the input function is represented by a Fourier series⁵. This series is then modified by the values of the system transfer function to obtain the series that represents the transient response. This resulting series is summed up to obtain the transient response. A sample transient is shown in Figure 4.

3 These computations are performed on a "floating decimal" scheme which permits eight significant figures to be carried on all numbers, within the magnitude range from 10^{-50} to 10^{+50} .

4 The characteristic equation is obtained by setting the denominator of the transfer function $\frac{n}{n_1}$ equal to zero.

5 A digital process has been programmed to compute the first 40 harmonic terms of a general periodic input in an average time of 3 machine hours. This process has proved very valuable in the reduction of flight test data.

This process has also been programmed for computation on the digital equipment. For example, to obtain the transient response to a step function input, the values of the transfer function at 40 to 200 discrete frequencies are used as inputs to the machine. (This data is the same data that was computed by the machine in the transfer function process described previously.) When 40 frequencies are used, the machine performs some 40,000 operations to obtain 50 points on the transient response in 2 machine hours. It is estimated that this operation performed by manual calculation would require approximately 60 man hours.

The transient analysis performed by the above process is very restricted for two reasons. First, the theory of the transfer function approach requires that the system be represented by linearized differential equations whose coefficients do not vary with time; second, the required digital machine time becomes prohibitive if large numbers of transients are desired, (1,000 to 5,000 may sometimes be required).

It is in the performance of an exhaustive transient analysis of the system that analog computer equipment has proved so useful. Employment of analog equipment permits a very complete study of nonlinear phenomenon and 3-axis coupling problems, and it also permits realistic evaluation of transients when component characteristics change appreciably during the time of the transient. For example, the aerodynamic parameters change throughout the flight of a missile because the velocity and/or altitude is continually changing. These complicated analyses can be conducted by solving the set of simultaneous differential equations (nonlinear or time varying) digitally, but this is very time consuming. It should be mentioned, however, that a digital solution of this sort is often required as a check problem⁶ for an analog setup.

One important system nonlinearity is that associated with the aerodynamic restoring moment as the missile rotates away from zero angle of attack, i.e., the aerodynamic spring. A typical variation is shown in Figure 5. The dashed lines on the figure show the linear approximations made for use in the digital frequency analysis. Analog equipment permits the inclusion of the actual characteristic. A similar nonlinearity is associated with most power servos and is analyzed in the same manner.

Another important nonlinearity is associated with measuring instrument pickoff granularity. This problem is illustrated in Figure 6 for a wire wound potentiometer pickoff. Again, the dashed line represents the linear approximation used in the digital frequency analysis. The true characteristic is almost impossible to include in a digital analysis, but it may be included readily in an analog analysis by driving wire wound potentiometers with a computer servo. A sample transient showing the effect of too coarse pickoff granularity is shown in Figure 7.

Aerodynamic cross coupling phenomenon, because of their nonlinear nature, are also very difficult to study by digital techniques, but they may be studied readily by means of analog equipment.

⁶ The ratio of digital to analog machine running time may be of the order of 1000 to 1 for these check problems.

Another important advantage of using analog equipment can be realized if a real time scale can be employed in the analog (i.e., the analog works at the same speed as the actual system). The aerodynamics and measuring instruments can be represented by analog equipment. The output voltage of these analogs can be feedback through the actual electrical network to drive the power servo. The power servo in turn drives the analogs, thus obtaining a very realistic simulation. Transients may be run very quickly on such a piece of equipment, but it is not as flexible as a more general setup. It does have a distinct advantage in that hardware which is difficult to represent by differential equations can be used in its exact role in the system. However, some analyses performed with analog equipment require that the system be analoged on an extended time scale so that the dynamics of the computer servos do not distort the results. This extended time scale prevents the use of actual components in the analog:

Conclusions

The use of both digital and analog equipment permits a much more optimum design than could possibly be achieved in the absence of such equipment. Digital equipment has some advantage in the accuracy of solutions, but the accuracy of analog equipment is sufficient for most autopilot engineering purposes. Digital equipment has a distinct advantage in that it permits the use of familiar analysis techniques which have been developed in communication engineering; the digital equipment simply performs the labor involved in applying these techniques to complicated autopilot systems. The frequency analysis performed on the digital equipment seems to give a better qualitative understanding of how the various parameters effect the system stability and basic response characteristics and provides a firm general design foundation; the transient analysis performed on analog equipment seems to be the only practical way of studying certain nonlinear phenomenon. However, digital equipment is usually required to solve check problems for the analog equipment.

It must be recognized that the computer tools available to the system designer have a major influence upon the nature of the completed design (i.e., hardware specifications). Access to digital computers with the consequent thorough system frequency analysis permits a more optimum selection of component dynamic characteristics. However, a design that is completed on digital equipment only, tends to be as linear as possible; the use of analog equipment may permit the designer to exploit some of the advantages of nonlinear systems. The design that is completed on the basis of linear theory tends to be over conservative in regard to allowable tolerances, whereas the use of analog equipment generally permits a more realistic evaluation of the tolerances, and may greatly alleviate some production problems. In addition, the use of analog equipment gives the designer the distinct advantage of using actual components in the solution of problems.

The use of digital and analog equipment tends to result in a much more complete design than would have been obtained without this equipment, but the cost of the design is usually increased because so many more cases and conditions are investigated. The real saving is made in the flight test program which tends to be shorter, more successful, and to require fewer test vehicles.

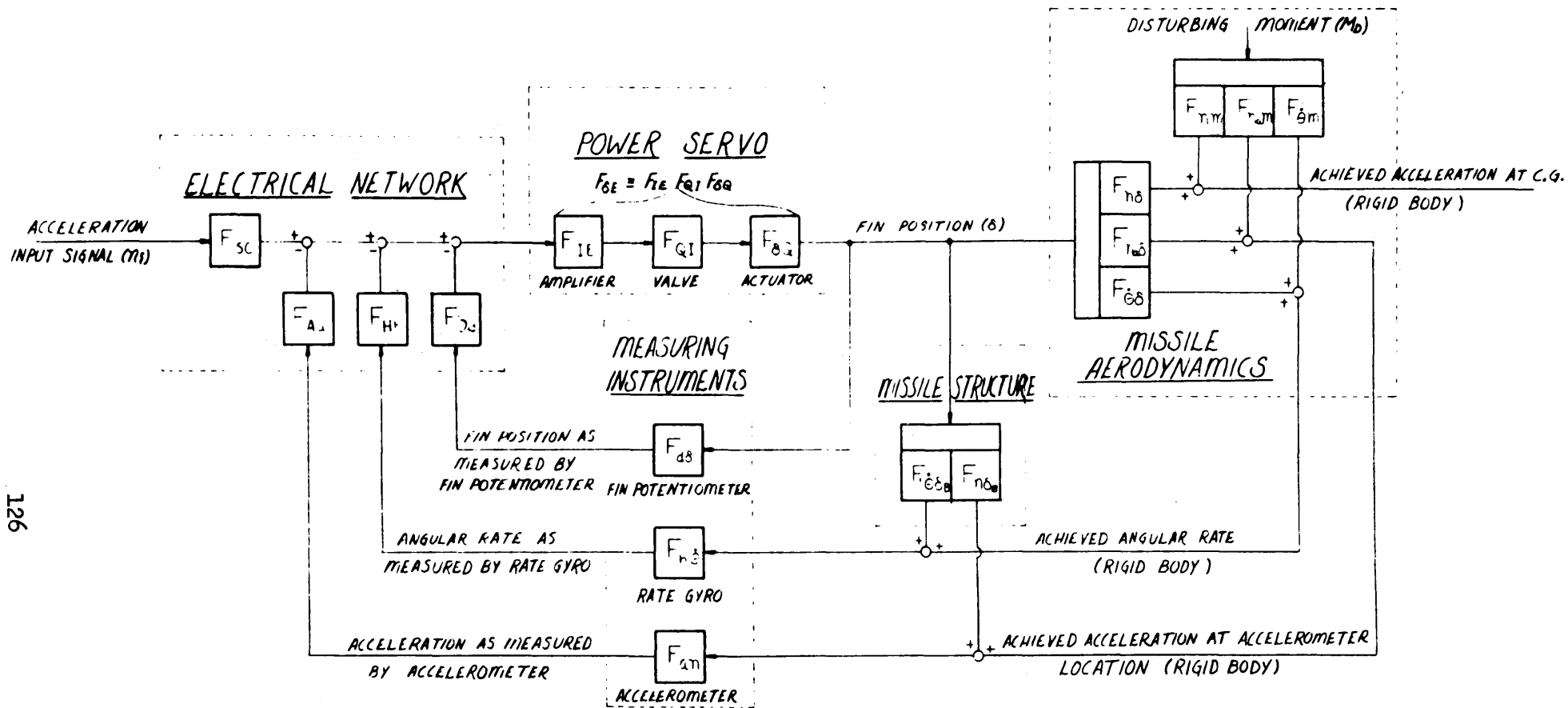

LATERAL ACCELERATION CONTROL SYSTEM BLOCK DIAGRAM

FIGURE 1

NYQUIST DIAGRAM

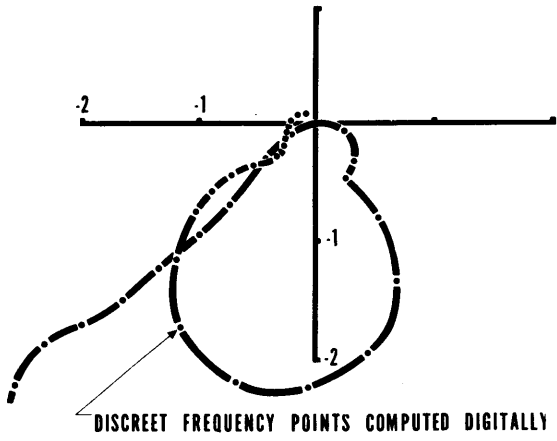

Fig. 2

SYSTEM TRANSFER FUNCTION

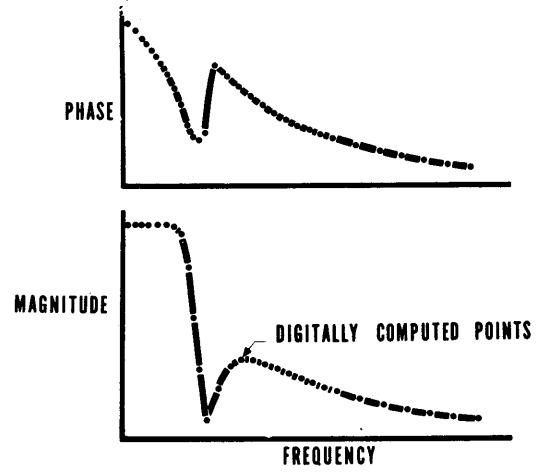

Fig. 3

TRANSIENT RESPONSE

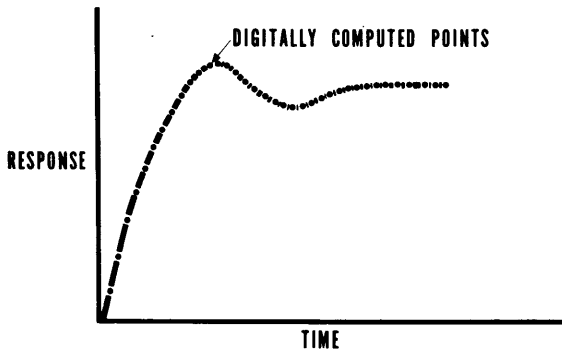

Fig. 4

AERODYNAMIC RESTORING MOMENT

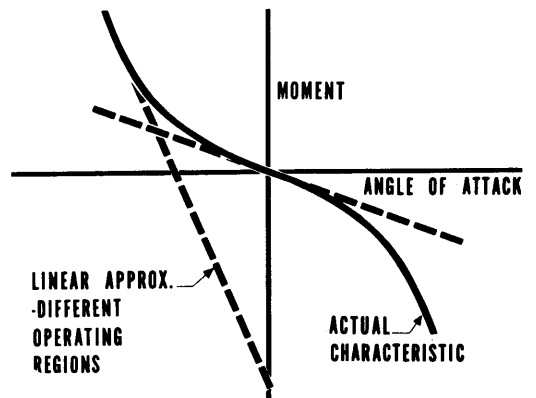

Fig. 5

POTENTIOMETER GRANULARITY

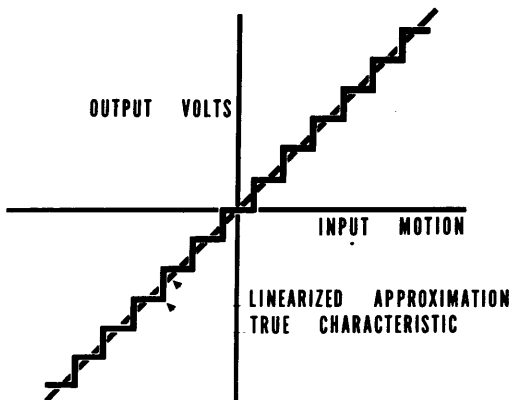

Fig. 6

ANALOG COMPUTED TRANSIENT
POTENTIOMETER GRANULARITY TOO COARSE

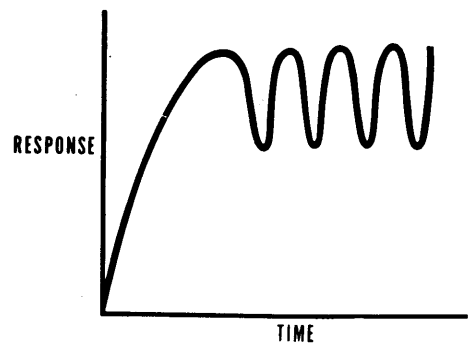

Fig. 7

APPLICATIONS OF COMPUTERS TO AIRCRAFT DYNAMIC PROBLEMS

B. Hall
R. Ruthrauff
D. Dill

Douglas Aircraft Company, Inc.
Santa Monica, California

Aircraft dynamic problems present a major field for the application of modern digital and analog computers. While it is true that airplanes were designed before the advent of these computers, the design requirements of aircraft have advanced simultaneously with the computer development programs. Today the efficient design of high speed aircraft depends to a large extent on the rapidity with which a large volume of calculations on dynamic problems can be completed.

The applications of computers may best be illustrated by considering four general categories of dynamic problems:

1. The problems dealing with long period control of aircraft and missiles during part of or the entire flight time;
2. Rigid body dynamic problems;
3. Problems of the elastic aircraft at zero frequency; and
4. The elastic aircraft with finite inertia, the flutter problem.

Before discussing each category, it is necessary to point out that the four classifications are extremely dependent on each other. It is only because of simplifying assumptions that one is able to consider them separately.

In the first category a missile or airplane is considered to be at rest or in flight. If the craft is at rest, some propulsive force is applied and the resulting motion is to be computed. If the craft is in flight some natural or induced disturbance is applied to the craft and again the resulting motion is to be computed. As an example of problems typical to this group, consider a missile trajectory problem. Assume, for the purpose of simplification, that the missile is constrained to move in only two directions: range and altitude. At any instant of time the geometrical conventions in Figure 1 are used to describe its motion and position in its flight path.

The trajectory of the missile is determined by the following equations:

$$\ddot{y} = \frac{g}{W} \left[(T-C)(\cos \theta \cos \alpha - \sin \theta \sin \alpha) - N(\sin \theta \cos \alpha + \cos \theta \sin \alpha) \right]$$
$$\ddot{z} = \frac{g}{W} \left[(T-C)(\sin \theta \cos \alpha + \cos \theta \sin \alpha) + N(\cos \theta \cos \alpha - \sin \theta \sin \alpha) \right] - g$$

In these equations the parameters are defined as follows: T, the thrust which is directed along the axis of the missile; C, the chord force opposite to T along the same axis; ϕ , the climb angle; and α , the angle of attack. N is the normal force on the missile and W its weight. The angle α may vary between 0 and 30 degrees while ϕ may lie between plus or minus 90 degrees, a range which indicates the high degree of non-linearity of the system. As is indicated in Figure 2, some of these quantities are discontinuous functions of time.

The missile is launched with the booster motor burning. At the end of a specified time the booster is dropped and the missile glides prior to motor burning. It is at this point that the calculation of the trajectory begins. On the graphs in Figure 2, time t_0 is actually the beginning of the glide phase.

t_a denotes the time of missile motor burning and is accompanied by a corresponding loss in weight due to fuel consumption. At the time of motor burnout, t_b , the thrust returns to zero and the weight following the jettisoning of excess fuel remains constant.

In the actual integration of the equations of motion a step by step method of solution is employed. At time t_i the values of $y_i, \dot{y}_i, \phi, \dot{\phi}$ are available. The corresponding values of these quantities for time t_{i+1} may be approximated by the following formulas:

$$\dot{y}_{i+1}^{(b)} = \dot{y}_i + \ddot{y}_i \Delta t$$

$$y_{i+1}^{(b)} = y_i + \frac{\Delta t}{2} (\dot{y}_i + \dot{y}_{i+1}^{(b)})$$

Using these values $\ddot{y}_{i+1}^{(b)}$ may be formed. Then the values $y_{i+1}^{(b)}, \dot{y}_{i+1}^{(b)}, \ddot{y}_{i+1}^{(b)}$ may be improved by the following equations:

$$\dot{y}_{i+1}^{(c)} = \dot{y}_i + \frac{\Delta t}{2} \{ \ddot{y}_i + \ddot{y}_{i+1}^{(b)} \}$$

$$y_{i+1}^{(c)} = y_i + \frac{\Delta t}{2} \{ \dot{y}_i + \dot{y}_{i+1}^{(c)} \} + \frac{\Delta t^2}{12} \{ \ddot{y}_i - \ddot{y}_{i+1}^{(b)} \}$$

which may then be used to determine $\ddot{y}_{i+1}^{(c)}$. An identical procedure is used to form $z_{i+1}, \dot{z}_{i+1}, \ddot{z}_{i+1}$.

This integration process has proved to be quite accurate as is evidenced by the trajectory in Figure 3. The graph records the time history of an actual missile flight together with the trajectory obtained by the procedure outlined above. The actual path of motion is indicated by the solid line, while the digital reproduction of this run, which had for its initial conditions experimental values obtained from the end of boost conditions, is the solid line with circles.

In the second group, problems involving the rigid airplane are studied. The craft is allowed to have 6 degrees of freedom, (Figure 4), with aerodynamic and inertia forces acting upon it. For stability calculations the degrees of freedom may frequently be considered in groups. For instance, the pitching and vertical motion are considered separately from rolling, yawing and sideslip for small amplitudes of motion. The former are the longitudinal degrees of freedom and the latter are the lateral degrees of freedom. Providing linear aerodynamic forces are employed, the solution of the stability problem is relatively simple. The

following equations are typical of the lateral stability problem.

$$I_x \ddot{\Phi} - C_{L\dot{\Phi}} \dot{\Phi} - I_{xz} \ddot{\Psi} - C_{L\dot{\Psi}} \dot{\Psi} - C_{L\beta} \beta = 0$$

$$I_z \ddot{\Psi} - C_{n\dot{\Psi}} \dot{\Psi} - I_{xz} \ddot{\Phi} - C_{n\dot{\Phi}} \dot{\Phi} - C_{n\beta} \beta = 0$$

$$\frac{2b\mu}{V} [\dot{\Psi} + \dot{\beta}] - C_v \dot{\Phi} - C_{y\dot{\Phi}} \dot{\Phi} - C_v \Psi \tan \gamma - C_{y\dot{\Psi}} \dot{\Psi} - C_{y\beta} \beta = 0$$

The Army and Navy specifications require that lateral directional oscillation be damped within a certain time, depending on the period of oscillation, Figure 5. The motion of particular concern here is one in which the plane yaws and rolls to the right, followed by a recovery toward the equilibrium position and an overshoot consisting of a yaw and roll to the left. If this motion is not sufficiently damped, it may become very bothersome.

The moments of inertia in the equations may be roughly computed by slide rule using standard formulas, or for more accurate determination computing equipment is frequently employed. The coordinates employed in the above equations are the same as those defined in Figure 4. I_x , I_{xz} , etc. are the moments and products of inertia. The C's are the aerodynamic coefficients. Wherever possible the aerodynamic terms of the stability problem are derived from wind tunnel scale models. If these data are not available, the derivatives are estimated by ratio with other airplanes of similar but known aerodynamic characteristics.

Having determined the coefficients of the equations, an Eigenvalue problem remains to be solved. The real part of the root will yield the damping and from the imaginary part the period is determined. With this information the degree of lateral stability may be located on the specifications chart Figure 5.

Because of the relative sizes of the coefficients in the equations of motion, it is difficult to solve for the roots. This problem is presently being solved by first finding the characteristic equation by direct expansion, and then solving the equations by any one of numerous methods. The expansion and solution is programmed for one continuous operation on the IBM card programmed calculator (CPC). One particularly valuable method of solution known as the Lin and Barstow method, extracts quadratic factors from the equation. The quadratics are solved by the quadratic formula, and the remaining polynomial is treated in a similar fashion. Frequently linear factors are taken from the polynomial as an alternative method.

As a second example dealing with the rigid airplane, a rolling pull out maneuver will be considered. In this problem the airplane pulls out of a dive at constant acceleration. When the airplane becomes horizontal, the ailerons are deflected initiating a roll, and the aerodynamic forces on the vertical surface may exceed the structural limit during the maneuver. The problem is to calculate these loads for different initial accelerations and for different magnitudes of aileron deflection. The equations used to solve this problem are shown below.

$$\dot{\beta} = \alpha \rho - \dot{\alpha} + K_{11} \cos T_2' + K_{12} \beta + K_{13} \dot{\alpha} + K_{14} \rho + K_{15} \beta \alpha^2$$

$$\alpha = \dot{\alpha} - \beta \rho + K_{12} \cos T_2' + K_{22} \alpha + K_{23} \dot{\alpha} + K_{24} \alpha^3 + K_{25} \alpha \beta + K_{26} \alpha \beta \dot{\alpha} + K_{27} \alpha \beta \rho$$

$$\dot{\rho} = K_{31} \dot{\alpha} + K_{32} \rho + K_{33} \dot{\alpha} + K_{34} \alpha \dot{\alpha} + K_{35} \beta + K_{36} \dot{\alpha} + K_{37} \alpha \beta$$

$$\dot{\alpha} = K_{41} \rho \dot{\alpha} + K_{42} \rho + K_{43} \alpha \rho + K_{44} \dot{\alpha} + K_{45} \beta$$

$$\dot{\dot{\alpha}} = K_{51} \dot{\alpha} \rho + K_{52} \alpha + K_{53} \dot{\alpha} + K_{54} \dot{\alpha} + K_{55} \alpha + K_{56} \beta^2$$

$$\cos T_1' = r \cos T_2' - q \cos T_3'$$

$$\cos T_2' = p \cos T_3' - r \cos T_1'$$

$$\cos T_3' = q \cos T_1' - p \cos T_2'$$

$T_{1,2,3}'$ ARE THE DIRECTION COSINES OF THE GRAVITATIONAL VECTOR

β IS THE SIDESLIP ANGLE.

α IS THE ANGLE OF ATTACK.

p IS ROLLING VELOCITY.

r IS YAWING VELOCITY.

q IS PITCHING VELOCITY.

This problem has gained a great deal of complexity from the previous example, since aerodynamic forces are now considered to be non-linear. A complete discussion of the terms in these equations is not consistent with the purpose of this paper. It is sufficient to note that the inertia terms are included in the coefficients $K_{11}, K_{12}, K_{13}, K_{14}, K_{15}$ and the remaining coefficients define the aerodynamic forces. These coefficients are also obtained from wind tunnel data wherever possible. Since the time history of the velocity of the vertical surface is required, the roots associated with an Eigenvalue problem would not immediately yield the desired information. To solve this problem the REAC was found to yield fast, accurate solutions for various inputs. The REAC diagram for this problem is shown in Figure 6. Blocks A through E integrate the 5 differential equations. In some cases it is necessary to use an isolating amplifier to distribute the output of the integrators to the different parts of the circuit. Blocks F, G and H are used to satisfy the equations determining the gravitational vector. Blocks I, K, L, M, N, P, R, are the servo units producing the non-linear terms. The term denoted by $K_{24}t$ determines the rolling moment due to aileron deflection. This term is represented on the REAC by the relay circuit in the lower left hand corner. The input deflection is a square wave of arbitrary magnitude.

The results are obtained by recording the time history of the sideslip angle β . For large values of β the aerodynamic force on the vertical tail surface exceeds the structural limit and failure occurs.

In the problems of the first two categories it is assumed that the aircraft is responding as a rigid body to the imposed forces. In the present section the problems under consideration will contain the actual deformations of the wing under aerodynamic forces. These studies will be carried out with the omission of the inertia terms present in the previous categories. The example problem of this category is that of finding the span loading of a flexible swept wing. It is generally convenient to divide the wing into sections as shown in Figure 7. Each section will be coupled to the adjacent section by springs computed from the stiffness properties of the wing. The springs are arranged to allow the wing to bend in a vertical plane and to twist about its spanwise axis. In addition to the spring restraints, aerodynamic lift and moment act upon each section. Assume that the aerodynamic constants of each section, the design load on the rigid wing, and the built in angle of attack distribution are known. From these conditions the strength engineer can compute the stiffness the wing requires to support the load. As soon as this finite stiffness is introduced, the wing is

free to deform, and this deformation will in turn redistribute the load on the wing. The following iterative procedure is successfully employed to compute the final load and deformation of the wing. The iteration procedure is carried out as one continuous operation on the CPC. With the aerodynamic and assumed elastic parameters and the operating conditions stored in the memory register of the card program calculator, the machine computes a new angle of attack distribution from the rigid body loads by the following formula:

$$\Delta \alpha_n = \frac{1}{G} \left[\frac{\Delta y}{J} \right]_n T_n - \frac{TAN \Lambda}{E} \left[\frac{\Delta y}{I} \right]_n M_n$$

$\Delta \alpha$ = CHANGE IN ANGLE OF ATTACK	C_n = CHORD
GJ = TORSIONAL STIFFNESS	S = WING AREA
Δy = LENGTH OF SECTION	V = SHEAR
T_n = TORSION MOMENT	$\frac{dC_L}{d\alpha}$ = LIFT CURVE SLOPE
Λ = SWEEP ANGLE OF WING	q = DYNAMIC PRESSURE
EI = BENDING STIFFNESS	$ea-ac$ = DISTANCE FROM ELASTIC
M_n = MOMENT OF THE SECTION	AXIS TO AERODYNAMIC CENTER.

A constant angle of attack determined by

$$\alpha_1 = - \sum_n \frac{C_n \Delta y_n}{S} \Delta \alpha_n$$

is added to the new angle of attack distribution, thus keeping the total load on the wing constant. With this normalized angle of attack distribution, new loads are computed for each section by the following formulas:

$$\begin{aligned} V_n &= 0 & n &= K \\ V_n &= V_{n+2} + q \left(\frac{dC_L}{d\alpha} \Delta y \cdot C \right)_{n+1} \alpha_{n+1} & n &= 2, 4, \dots, K-2 \\ M_n &= 0 & n &= K \\ M_n &= M_{n+2} + \frac{\Delta y_{n+1}}{\cos \Lambda} V_{n+2} + \left(\frac{dC_L}{d\alpha} q \Delta y e \right)_{n+1} \left\{ \frac{\Delta y}{2 \cos \Lambda} - (ea-ac) C \sin \Lambda \right\}_{n+1} \\ T_n &= 0 & n &= K \\ T_{n+2} + \cos \Lambda \alpha_{n+1} & \left[\frac{dC_L}{d\alpha} q \left\{ C^2 \Delta y (ea-ac) \right\} \right] & n &= 2, 4, \dots, K-2 \end{aligned}$$

With the new wing loading the process may be repeated until convergence is reached. If the loads or angle of attack distribution differ radically from the original loads, the wing stiffness may have to be modified to obtain the desired load and deformation characteristics.

In dealing with the dynamic stability of the airplane in the higher frequency ranges of the fourth category, it is necessary to include not only the aerodynamic forces and elastic deflections, but also the local mass and inertia effects. This

gives rise to very complicated sets of equations, the solution of which leads to a serious computing problem. However, the danger involved in high frequency dynamic instability, generally called flutter, is such that these calculations must be performed, and a great deal of effort has been expended by engineers and mathematicians in trying to find ways of employing computing machines in the solution of this problem.

Two quite different approaches have been used successfully in the Douglas Aircraft Company, and will be described here. The first and older technique is digital in character and uses IBM computing equipment. The second method employs the California Institute of Technology analog computer which sets up electric circuits having the same dynamic characteristics as the aircraft system.

When digital methods are used the work is done almost entirely by matrix manipulation. Although the equations of motion are linear, the aerodynamic forces contain time lags which in the usual formulation lead to complex coefficients in the equations of motion. When the number of degrees of freedom is high (say greater than seven) considerable difficulty is experienced in obtaining accurate values of the frequencies and stability (damping) of all of the possible flutter modes. As a consequence every effort is made to minimize the number of degrees of freedom. The method usually followed uses the natural modes of vibration as degrees of freedom. In other words it is assumed that the deflection configuration of the airplane structure when flutter occurs can be made up of a linear combination of the natural ground vibration modes. These ground vibration modes may be either calculated or measured during ground vibration tests.

Given these data the detailed procedure is as follows:

The wing or tail surfaces are divided into sections as shown in Figure 7 and the mass, center of gravity, and pitching inertias are computed for each section. Aerodynamic force and moment coefficients must be calculated for each section for a range of ratios of velocity to frequency. When this is done, the final equations may be formed by a process based on the principle of virtual work.

This process leads to the formation of generalized force coefficients for the inertia, aerodynamic, and elastic terms from the sectional values of these quantities. Thus if W_i represents a mass matrix for the i th section and N_i is the corresponding aerodynamic matrix, then $\bar{M} = \sum_i \phi_i^* W_i \phi_i$ and $\bar{L} = \sum_i \phi_i^* N_i \phi_i$ will represent generalized force coefficient matrices. The transformation matrix ϕ_i represents the relative deflections at section "i" due to the various modes of vibration employed, and ϕ_i^* is the transpose of the matrix ϕ_i . The generalized elastic constant matrix \bar{Z} is usually computed from \bar{M} and a knowledge of the ground natural frequencies.

If q is a column matrix of the magnitudes of the various ground modes present in flutter, the final equations become $\{A - zI\}q = 0$ where $A = \bar{Z}^{-1} \{\bar{M} + \bar{L}\}$ and $z = \frac{1}{wI} (1 + j\zeta)$, w is the frequency of flutter, and ζ is an index of the system stability.

The matrix equation $\{A - zI\}q = 0$ will have non-trivial solutions only if the determinant $|A - zI| = 0$ which yields an algebraic equation in z called the characteristic equation. A number of methods for obtaining the complex characteristic equation have been used. However, in general, a direct expansion of the determinant is used for four degrees of freedom or less. This work

including the computation of the roots of the complex fourth order equation is programmed for one continuous operation on the CPC. For higher orders than the fourth, Leverrier's method is used. This involves computing powers of the matrix $A = \mathcal{C}^{-1}(Z + \mathcal{A})$ and applying the following formulas:

$$S_1 = \sum \text{Diagonal Terms in Matrix } A$$

$$S_2 = \sum \text{Diagonal Terms in Matrix } A^2$$

$$S_3 = \sum \text{Diagonal Terms in Matrix } A^3$$

$$S_4 = \sum \text{Diagonal Terms in Matrix } A^4$$

$$S_N = \sum \text{Diagonal Terms in Matrix } A^N$$

The characteristic equation is:

$$Z^N + bZ^{N-1} + cZ^{N-2} + dZ^{N-3} + eZ^{N-4} \dots f = 0$$

where

$$b = -1 (S_1)$$

$$c = -1/2 (S_2 + b S_1)$$

$$d = -1/3 (S_3 + b S_2 + c S_1)$$

$$e = -1/4 (S_4 + b S_3 + c S_2 + d S_1)$$

$$f = -1/N (S_N + b S_{N-1} + c S_{N-2} + d S_{N-3} + e S_{N-4} \dots)$$

In some instances it is found that Leverrier's Method for calculation of the characteristic equation requires that a large number of figures be carried. If sufficient figures are not retained, the last few coefficients of the characteristic equation become inaccurate.

An alternate method for calculation of the last coefficients by determinants is as follows:

Coefficients of a six-degree characteristic equation:

$$e = 1/2(D_{+1} + D_{-1}) - 1 - c - D_0$$

$$f = 1/2(D_{+1} - D_{-1}) - b - d$$

$$g = D_0$$

Coefficients of a seven-degree characteristic equation:

$$f = -1/2(D_{+1} + D_{-1}) - b - d + D_0$$

$$g = 1/2(D_{-1} - D_{+1}) - 1 - c - e$$

$$h = -D_0$$

In the above equations

b)
c) = Coefficients of the characteristic equation previously determined
d) by Leverrier's Method
e)

A = Normalized matrix for which characteristic equation is being determined.

$D_0 = A$

$D_{+1} = A - I$

$D_{-1} = A + I$

Having obtained the complex characteristic equation, the roots are found by an iterative process, employing synthetic division and Newton's method.

It is hoped that the foregoing example will sufficiently illustrate the complexity of the flutter problem, and make clear the need for automatic computing machinery in this field.

The other method successfully used in attacking the flutter problem employs the analog computer developed at the California Institute of Technology. In using this machine the wing is also broken into sections, and the same physical properties as before must be computed. An electric circuit is formed which matches each of these sections and their elastic connections. In the electric circuit analogy voltage corresponds to velocity, current to force, capacity to mass and so forth. The aerodynamic forces must be simulated by means of amplifiers. The circuit for a typical section is given in Figures 8A, 8B and 8C.

When the analogical system has been set up, its behavior under various electrical impulses may be observed on an oscilloscope and photographed if desired. The excitation may correspond to the airplane entering a sudden gust, or it might simulate a vibrator placed in a wing. In any case the dynamic stability and frequency of the system may be observed. Examples are given in Figure 9.

One great advantage of the analog method of solution is the ease with which physical parameters of the airplane can be changed. If the digital technique first described is employed and it is desired, for example, to change the wing rigidity, new natural modes of vibration must be calculated before the process described can even begin. On the analog machine only the values of a few inductors need be altered.

In conclusion it may be stated that the Douglas Aircraft Company has successfully made use of a number of different computing machines of both the digital and analog varieties. No comparison of the relative merits of these various types will be made, since experience has shown that each type has advantages depending on the nature of the problem. In any event the use of computing machinery has become practically essential to modern aircraft engineering, and this trend will undoubtedly continue as further developments in this field take place.

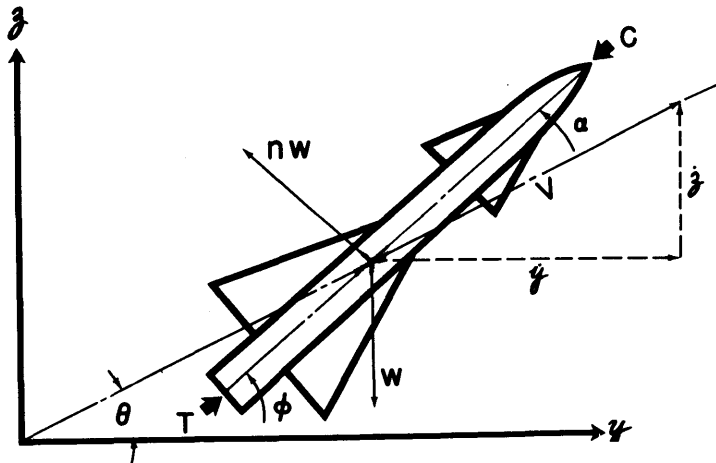

Figure 1 Geometry of Missile Flight.

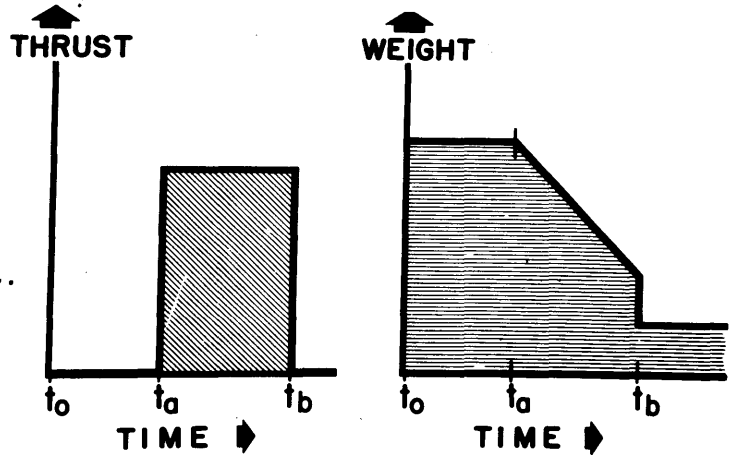

Figure 2 Discontinuous Functions of Missile Flight.

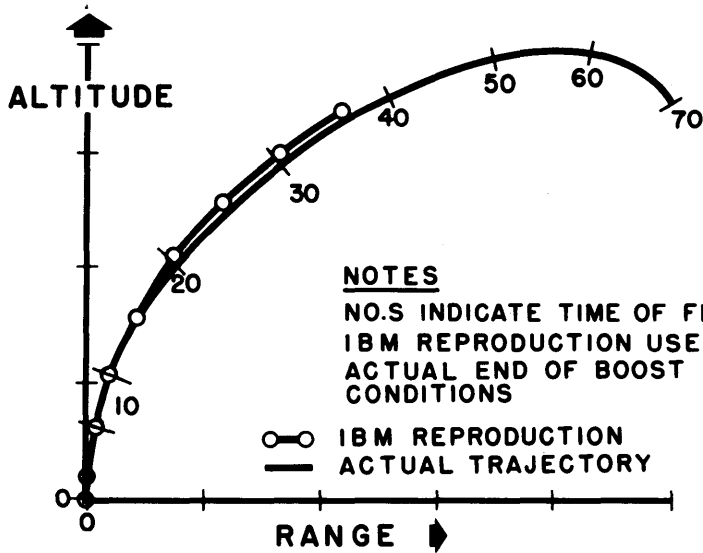
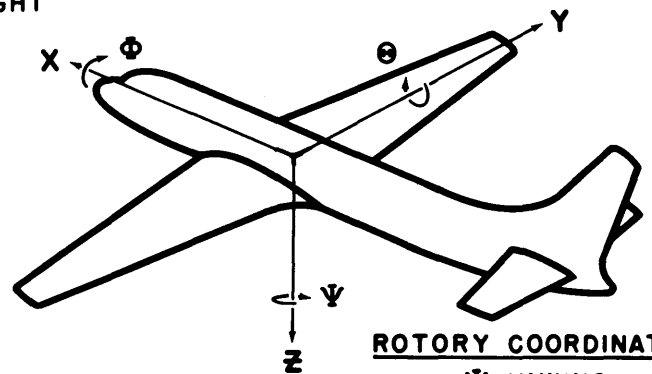

Figure 3 Missile Trajectory

NOTES
 NO.S INDICATE TIME OF FLIGHT
 IBM REPRODUCTION USED
 ACTUAL END OF BOOST
 CONDITIONS

○ IBM REPRODUCTION
 — ACTUAL TRAJECTORY



ROTARY COORDINATES

ψ YAWING
 θ PITCHING
 φ ROLLING

TRANSLATION COORDINATES

X LONGITUDINAL
 Y LATERAL
 Z NORMAL

$$\beta = \tan^{-1} \frac{\text{SIDESLIP VELOCITY}}{\text{FORWARD VELOCITY}}$$

Figure 4 Airplane Degrees of Freedom

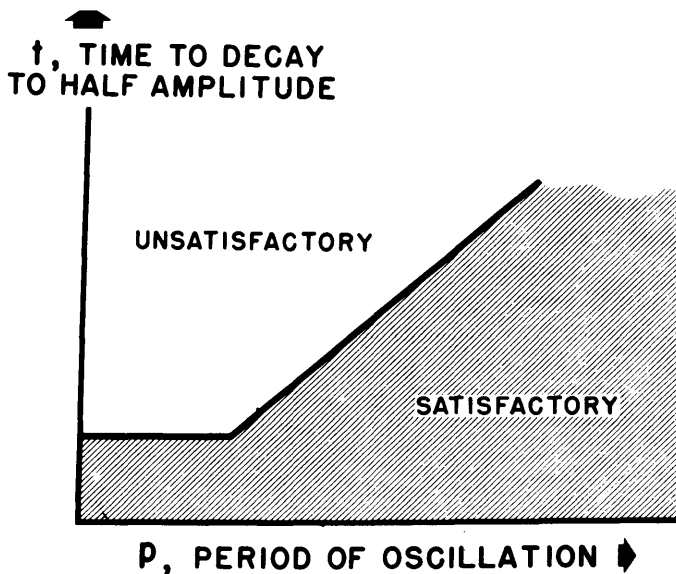
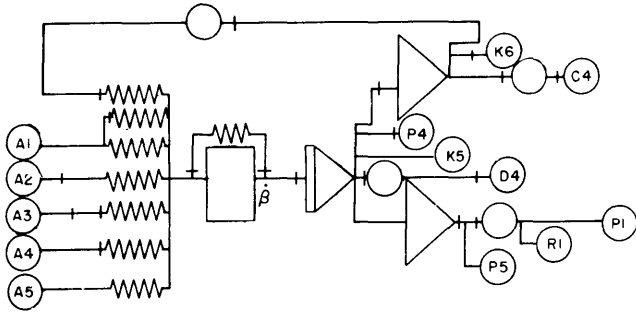

Figure 5 Stability Chart.

SUMMATION AND INTEGRATION OF SIDESLIP EQUATION, β



BLOCK A

SUMMATION AND INTEGRATION OF YAWING EQUATION, r

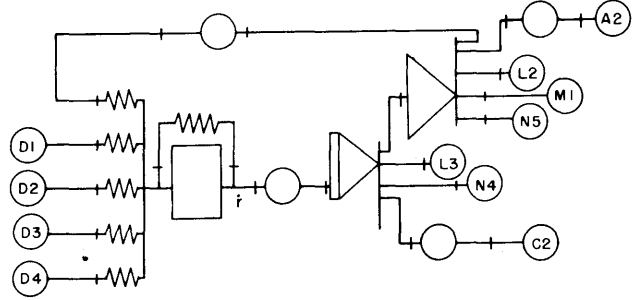

BLOCK D

SUMMATION AND INTEGRATION OF ANGLE OF ATTACK EQUATION, α

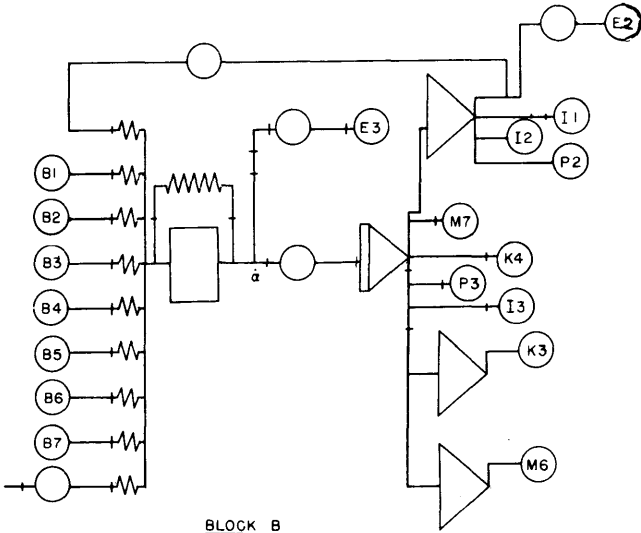

BLOCK B

SUMMATION AND INTEGRATION OF PITCHING EQUATION, q

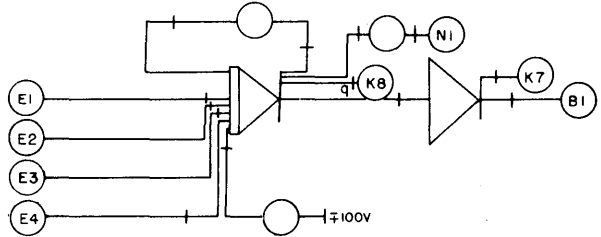

BLOCK E

GENERATION OF \bar{X} COMPONENT OF GRAVITATIONAL VECTOR

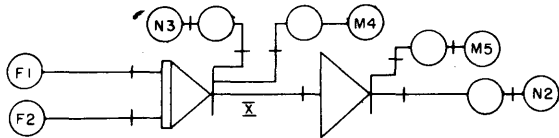

BLOCK F

SUMMATION AND INTEGRATION OF ROLLING EQUATION, p
GENERATION OF ROLLING MOMENT DUE TOAILERON DEFLECTION

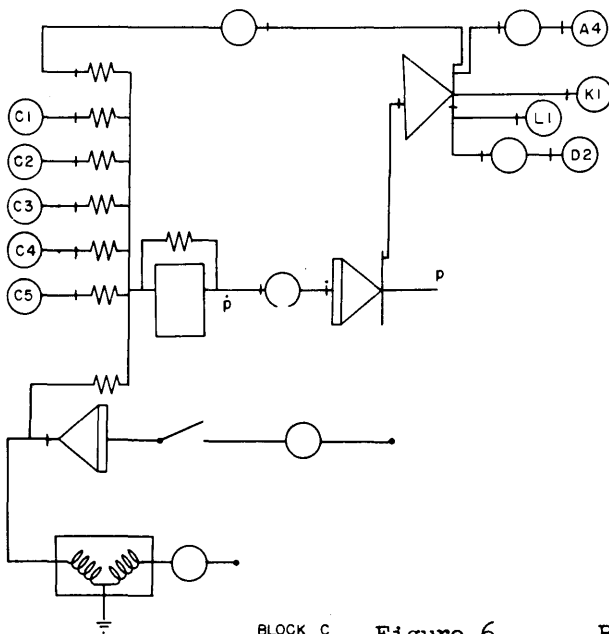

BLOCK C

Figure 6

GENERATION OF \bar{Y} COMPONENT OF GRAVITATIONAL VECTOR

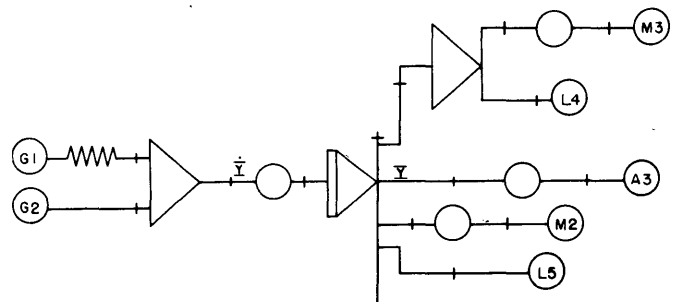

BLOCK G

GENERATION OF \bar{Z} COMPONENT OF GRAVITATIONAL VECTOR

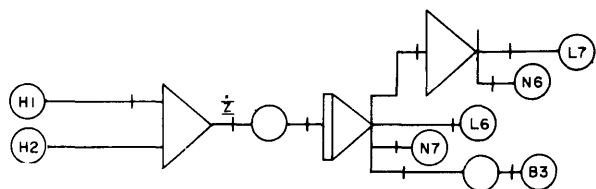

BLOCK H

REAC Block Diagram

GENERATION OF TERMS NON-LINEAR IN a

Figure 6 (Cont'd.)

GENERATION OF TERMS NON-LINEAR IN q

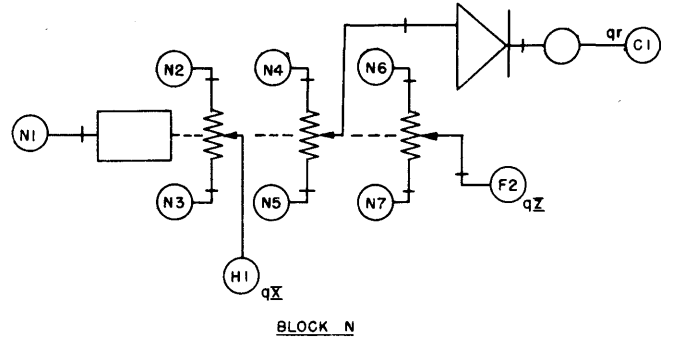
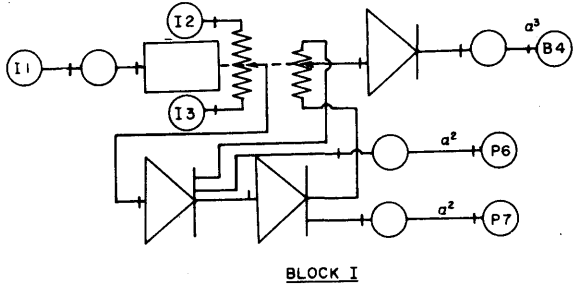

GENERATION OF TERMS NON-LINEAR IN p

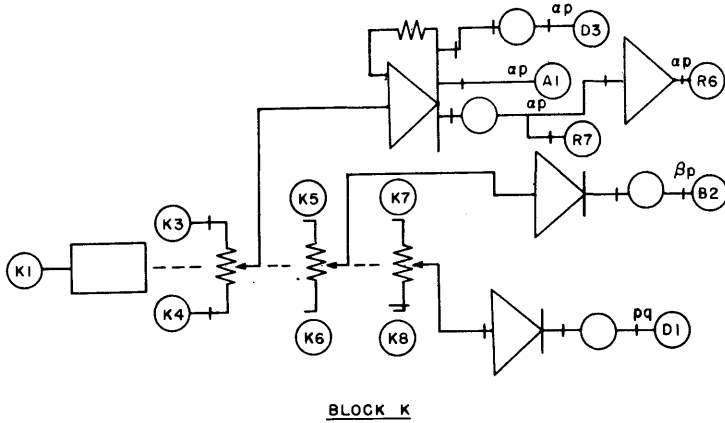

GENERATION OF TERMS NON-LINEAR IN β

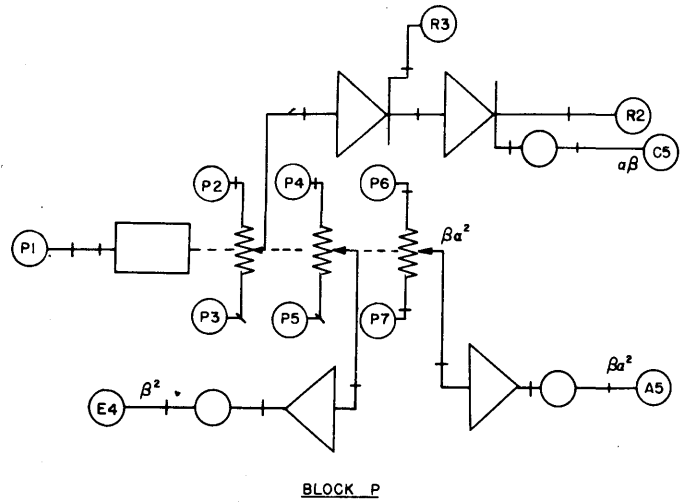

GENERATION OF TERMS NON-LINEAR IN p

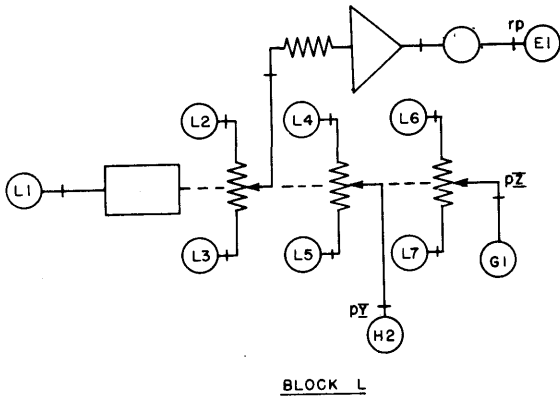

GENERATION OF TERMS NON-LINEAR IN β

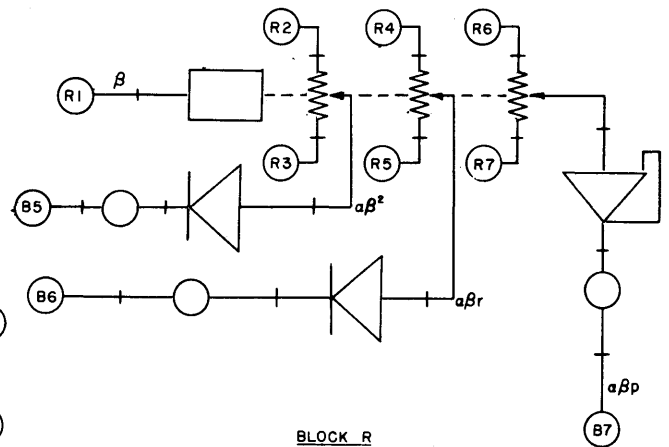
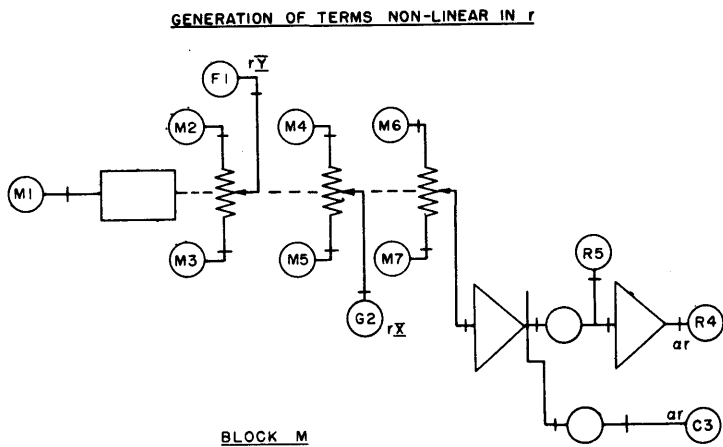

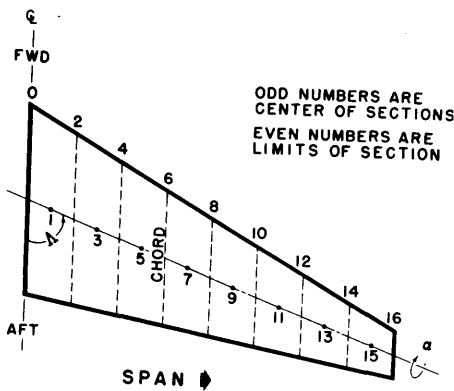

Figure 7 Section Division of Wing

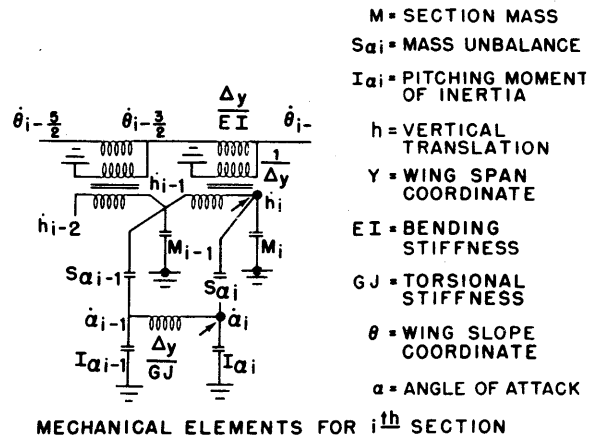

Figure 8A Analog Circuit for One Flutter Section.

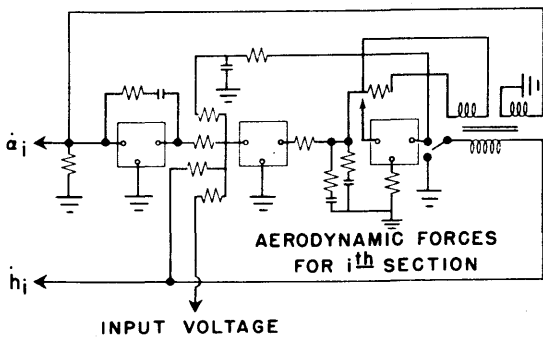

Figure 8B Aerodynamic Force Circuit.

- (1) $\theta_{i-\frac{3}{2}} - \theta_{i-\frac{1}{2}} = \frac{\Delta y}{EI} M_{i-1}$ SLOPE EQUATION
 - (2) $h_i - h_{i-1} = \Delta y \theta_{i-\frac{1}{2}}$ FIRST DIFFERENCE
 - (3) $M_i - M_{i-1} = \Delta y V_{i-\frac{1}{2}}$ MOMENT EQUATION
 - (4) $V_{i+\frac{1}{2}} - V_{i-\frac{1}{2}} = W_i \Delta y$ SHEAR EQUATION
 - (5) $\frac{GJ}{\Delta y} (y_{i+\frac{1}{2}}) [\alpha_{i+1} - \alpha_i] + \frac{GJ}{\Delta y} (y_{i-\frac{1}{2}}) [\alpha_{i-1} - \alpha_i] = T \Delta y$ TORQUE EQUATION
 - (6) $M_i \ddot{h}_i + S_{ai} \ddot{\alpha} + W_i \Delta y + \text{AERODYNAMIC LIFT} = 0$
 - (7) $S_{ai} \ddot{h}_i + I_{ai} \ddot{\alpha} + T \Delta y + \text{AERODYNAMIC MOMENT} = 0$
 - (8) $\text{AERODYNAMIC FORCE} = \beta_0 \left\{ \frac{C_1 + C_2 P}{C_3 + C_4 P} (\beta_1 h + \beta_2 \dot{\alpha} + \alpha) + \beta_3 \dot{\alpha} \right\}$
 - (9) $\text{AERODYNAMIC MOMENT} = (\text{MOMENT AT QUARTER CHORD}) + \text{LIFT (DISTANCE FROM REF. AXIS TO QUARTER CHORD)}$
- $P = \frac{d}{dt}$

Figure 8C Analog Equations for Typical Flutter Section.

RESPONSE OF WING TIP ENTERING SHARP EDGE GUST



DAMPED SINUSOIDAL RESPONSE OF WING TIP TO APPLIED IMPULSE

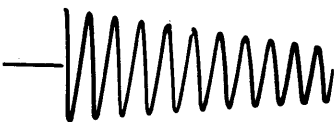

Figure 9 Response Curves of Analog Solutions.

THE SNAPPING DIPOLES OF FERROELECTRICS AS A MEMORY ELEMENT FOR DIGITAL COMPUTERS

Charles F. Pulvari
The Catholic University of America
Washington, D. C.

-SUMMARY-

A brief review is given of the memory properties of non-linear ferroelectric materials in terms of the direction of polarization.

A sensitive pulse method has been developed for obtaining static remanent polarization data of ferroelectric materials. This method has been applied to study the effect of pulse duration and amplitude and decay of polarization on ferroelectric ceramic materials with fairly high crystalline orientation.

These studies indicate that ferroelectric memory devices can be operated in the megacycle ranges.

Attempts have been made to develop electrostatically induced memory devices using ferroelectric substances as a medium for storing information. As an illustration, a ferroelectric memory using a new type of switching matrix is presented having a selection ratio 50 or more.

Introduction

High speed computing is, at the present, in a state of fermentation, and an intensive search continues for new computer and memory elements which are smaller and more reliable than those in present use.

All phenomena possessing two stable states are possible candidates for computer elements. The desirable characteristics of a computer or memory element may be summarized as follows:

1. High speed flip-flop (two stable states).
2. Small size per flip-flop or unit of information.
3. Low cost per unit of information.
4. Good memory properties without need for recycling.
5. Simple and reliable structure.
6. Convenient pulse operation.
7. Proper non-linearity of the flip-flop element such that very simple switching devices may be used.

The search for new computer and memory elements presents a two-fold problem if the elements are to be used in a switching matrix. First there is need for a material which meets the requirements listed in the second paragraph under Items 1, 2, 3, 4, 5 and 6; i.e. there is the problem of economical storage of information. Second, but of equal importance, is the switching problem. New computer and memory elements should have characteristics such that a random selection of the storage element could be easily performed. For this purpose Item 7 must be satisfied by providing the storage element with the "proper" non-linearity. It will be shown in this paper that the non-linearity of certain computer elements may be artificially increased by the use of proper circuit configurations.

Solid state physics presents many basic research opportunities in the growing field of high speed computing. This investigation was begun in 1940, when the "snapping dipoles" of ferroelectrics were proposed for memory devices in large scale digital calculators. It seemed clear however that a preliminary basic study of the significant properties of ferroelectric materials was necessary to confirm the practicability of this proposition. Proceeding along these lines, it was soon found (a) that the memory properties of ferroelectric materials in general, and BaTiO₃ in particular, had very promising features and (b) that there may be different approaches to the development of the use of these materials as memory elements. (1)* More importantly, it was recognized early in the investigation that the production of proper single crystals and a thorough understanding of the flip-flop action of snapping dipoles would be necessary prerequisites to the successful use of ferroelectrics in digital calculators.

*Numbers in parentheses refer to Bibliography at end of paper.

Snapping Dipoles of a Ferroelectric Material

A crystalline structure can be regarded as formed by as many uniform and parallel interpenetrating space lattices as there are ions in the unit cell. An electrostatic field causes a displacement of oppositely charged lattice centers from previous equilibrium positions. Thus different lattices of equal dipoles are induced. The response of ionic point lattices to an electric field depends on the constitution and microstructure of the lattice. (2)

The present investigation is concerned only with dipoles occurring in solids; three main types may be distinguished depending on nature of the displacement imposed on a particular atomic or molecular structure.

1. Dipoles may be induced by elastic displacement of an electronic or an ionic structure. In each case they exist only in equilibrium with an applied field. This type of dipole may be called simply, elastic dipole.
2. Dipoles which arise from binding forces between atoms in a molecule are permanent dipoles, and are inherent or firmly bound in equilibrium with the states of the material. Although material containing such dipoles may go through thermodynamic first-order transitions, they are not recognized as ferroelectric.
3. Recently a new type of permanent dipole was observed which arises from the very special intramolecular distance ratios of ionic spheres, which allow minute relative motion of ionic space lattices. Conditions for proper intramolecular spacing based on various considerations have been reported by many workers, as for example Mason and Matthias. (3)

Minute displacement of space lattices is accompanied by coupling of induced dipoles such that feed-back action may be visualized. Interaction of coupling and feed-back creates an intramolecular field which produces conditions such that two equilibrium states may occur in the structure. This type of dipole behaves like a free dipole in a solid; it may be called a "snapping" dipole, because, under the action of an external field, a network of dipoles jumps from one equilibrium position to another across the non-linear potential well. It has been recognized that if these snapping dipoles are in a single crystal structure a very fast "flip-flop" element would be possible with necessary properties for high speed operation needed in digital calculators.

Few materials possess snapping dipoles which may be identified as ferroelectric; barium titanate is one of these.

Signals Produced by Change in Polarization

For computer applications, a signal may be obtained from a condenser containing a ferroelectric dielectric. This signal is produced by change in polarization when a ferroelectric material is switched between its two equilibrium states. A physical picture of this action may be visualized as follows.

According to simple statistical considerations, when ferroelectric material is placed in an electric field N_1 cells assume one equilibrium condition and N_2 cells assume an opposite equilibrium condition. Knowing the dipole moment of one unit cell and the number of cells in particular equilibrium states, the remanent polarization may be computed, in the case of a single crystal, by:

$$P_r = (N_1 - N_2) \mu \quad [1]$$

where P_r is the remanent polarization, and μ the dipole moment. If the material under consideration is a polycrystalline ceramic, μ is replaced by $\bar{\mu}$, the average dipole moment taken over all orientations of the polycrystalline material. Thus, if charges are applied to a condenser containing a ferroelectric dielectric in order to produce a polarizing field, a certain quantity of these charges are bound, i.e., the surface dipoles of the dielectric are in equilibrium with the bound charges.

As long as the ratio of N_1 to N_2 does not change, i.e., the polarization is in a stable remanent state as in the case of a ferroelectric dielectric, the bound charges cannot be removed. When change in polarization occurs, the quantity of bound charges is altered in such a way that during an increase in polarization the dielectric seems to absorb charges, and during a reduction in polarization the dielectric appears to liberate charges. Thus, a ferroelectric dielectric material resembles a storage battery. Charges (electric energy) can be stored by polarizing the dielectric remanently. The stored charge may be released by two methods: (a) by randomizing the aligned dipoles, that is, by destroying the remanent polarization, (b) by changing the sign of the remanent polarization.

Figure 1 shows a family of hysteresis curves taken for different maximum values of electric field. Let it be assumed that the ferroelectric dielectric is originally in a random state (origin of coordinates). After the application and removal of each polarizing field a certain remanent polarization P_r , P'_r , P''_r , ... is obtained. These remanent polarizations bind on the condenser electrodes, certain quantities of charge Q , Q' , Q'' , ... If now, it is assumed that the total remanent polarization is completely randomized the charge Q , corresponding to P_r , is released and may be used to obtain a signal. Since the charge equals the product of remanent polarization and area and since it also equals the product of capacity and voltage, these equations may be combined with the simple equation for capacity with the following simple relation between field E , and remanent polarization P_r .

$$E = \frac{V}{\delta} = \frac{4\pi P_r}{\epsilon} \quad [2]$$

where ϵ is the dielectric constant of the ferroelectric dielectric, and δ the thickness of the dielectric material. Equation [2] shows that, if a

remnant polarization P_r becomes randomized, a field can be obtained across the condenser. If a "flip-flop" action occurs the sign of the remnant polarization is reversed and the change in polarization is given by $2P_r$; thus twice the field is obtained.

If a signal is developed across a capacitive load, the charge released by randomizing is distributed on all capacities involved. Figure 2 is the equivalent circuit of a signal measuring apparatus developed for these investigations. Total capacity in the equivalent circuit is given by

$$\sum_i C_i = \frac{Q}{V} \quad [3]$$

Since the voltage is distributed in inverse ratio to the capacities,

$$V_x = \sum_i C_i \frac{V_m}{C_x} \quad [4]$$

where V_x is the voltage on C_x , the actual storage element (See Fig. 5). The remnant polarization is, therefore:

$$P_r = \frac{\sum_i C_i V_m \epsilon}{4\pi \delta C_x} \quad [5]$$

where V_m is the voltage measured on all distributed condensers and $V_m/\delta = E$, the field produced by $Q = P_r$ (units of charge per unit area), when P_r is randomized. Having obtained P_r , the free charge after randomizing will be $Q = P_r A$; when the sign of P_r is reversed the charge is given by $Q = 2P_r A$. Thus, the free electric charge does not depend on the thickness of the material but only on the area of the condenser.

Barium Titanate Storage Elements

It has been recognized for some time, that single crystal plates of BaTiO₃ are most desirable for any type of memory application, since in single crystals hysteresis loops may be nearly rectangular and stability of remnant polarization is superior to that of polycrystalline ceramics. Accordingly it was decided to attempt to produce single crystals. However, the work necessary for establishing crystal growth is taking a longer time than anticipated because several auxiliary devices for the high temperature oven had to be constructed in the laboratory.

Consequently, one of the present aims of the research is to produce practical memory devices with existing ferroelectric ceramic materials. It appears that the production of a highly oriented ferroelectric ceramic plate for this purpose is very promising, and successive improvements in obtaining highly oriented ferroelectric ceramics will increase the practicability of such ceramics for memory devices. If such a BaTiO₃ ceramic is made sufficiently thin (about 0.15 to 0.25 millimeters) and is subjected to crystallization

conditions, some minute crystals tend to grow through the thickness dimension of the material.

Figure 3 is a photomicrograph of a thin sheet of Glenco ceramic, type X18 placed in front of a strong light source.* The thickness of the material is 11 mils. The small bright spots are crystal grains, some of which are presumably, single crystals. The abundance and scattered distribution of these crystal grains is clearly shown in the photograph.** The average dielectric constant of this material was found to be about 2500 at room temperature. Storage elements were formed by preparing condensers using silver paste electrodes placed on opposite sides of the ceramic plate. Capacity of specimen condensers varied from 50 to 180 micromicrofarads. Condenser areas varied between 1 and 4 square millimeters; a rather large surface was selected in the expectation that local effects of the irregularly distributed crystal grains would be obscured in an average integration of remanent polarization. To prevent voltage breakdown in the air surrounding the dielectric each condenser was encased by a protective plastic coating.

Figure 4 is a photograph showing the test condensers and several thin sheets of BaTiO₃ ceramics on which silver paste electrodes are fired.

Considerations in the Method of Measuring Remanent Polarization

Since no information was available on remanent polarization of ferroelectrics as function of amplitude and duration of applied field, it was decided to develop a standard method for comparative remanent polarization measurements. The time history, $P_r = f(E, t)$, (how the new steady state will be attained if E is a function of time) is a complicated statistical problem, particularly if a third parameter, decay of remanent polarization as a function of time, is also considered.

It has been found that while strongly polarized commercial polycrystalline barium titanate ceramic elements retain their remanent polarization for years, weakly polarized condensers lose polarization gradually; from this it would seem that a polycrystalline ceramic will not retain polarization for a long period of time. In single crystals, polarization occurs almost instantaneously in a group of cells (domains) and coupling and feed-back associated with the dipoles is sufficient to stabilize polarization. Although this research was designed to answer certain questions connected with decay of remanent polarization, it was believed that decay time is a function of overall crystal orientation.*** This indicated that, for memory purposes, development of highly oriented ferroelectric ceramics will be essential. It was hoped that if the orientation of a ceramic exceeds a certain critical value, practical stable signal storage would be possible.

* This material was manufactured by the Gulton Manufacturing Company.

** Courtesy of Dr. Dale C. Braungart, Department of Biology, Catholic University.

*** The overall crystal orientation may be defined as the ratio of the measured remanent polarization of a ceramic near breakdown to the maximum polarization obtainable in a single crystal (approx. 45,000 c.g.s.).

The desired information concerning remanent polarization includes:

- a. Shortest pulse duration producing a desired amount of remanent polarization.
- b. Rate of decay of remanent polarization as a function of pulse duration.
- c. Rate of decay of remanent polarization as a function of applied field.
- d. Information on breakdown voltage as a function of applied field and pulse duration.

The method of obtaining this information is indicated in Figure 5. The barium titanate condenser under inspection is acted upon by a d-c pulse, the sign of which may be reversed in order that a complete "flip-flop" can be obtained. The magnitude of remanent polarization of memory cell C_x under inspection may be determined by measuring the voltage developed by the memory cell as it is heated through the Curie temperature. The liberated charge is distributed on all capacities connected to C_x . Total load is then represented by C_L , the sum of C_1 , C_g , and C_o . For the measurements taken, load capacity varied from 4,000 micromicrofarads to 120,000 micromicrofarads depending on the sensitivity desired. The insulation of each memory element including all connections was better than 500 megohms. Using this method, the randomizing action of heat, high frequency, etc., can readily be studied and remanent polarization can be measured without difficulty. This method was chosen for its simplicity and high sensitivity and because no circuit complication need be taken into account. Furthermore, remanent polarization caused by snapping dipoles could be studied in itself without elastic displacement disturbances. By this thermal randomizing method remanent polarizations of approximately 15 cgs units (an extremely low value) to 25000 cgs units and higher can be obtained with good reproducibility.

Instrumentation

Figure 6 shows a block diagram of the experimental arrangement for measuring remanent polarization. The units are described as follows:

1. Trigger unit. This unit simultaneously initiated the sweep of a cathode ray oscilloscope and a pulse generator. It can either deliver single 0.05 microsecond pulses or be driven at a repetition rate of 10 to 20,000 cps.
2. Pulse generator. The pulse generator delivers d-c pulses, variable in amplitude and in duration. The output impedance is of the order of a few hundred ohms. When short duration pulses of approximately 2 to 3 microseconds are needed, a blocking oscillator is connected to the 3E29 input of the d-c pulser; the blocking oscillator is fired by the trigger unit.
3. Blocking oscillator. This unit delivers a 0.01 microsecond trigger pulse at 1000volts.
4. CRO. An oscilloscope enables the operator to view the waveform of the pulse applied to the barium titanate condenser and gives a measure of duration and amplitude.
5. Electrometer. The Lindemann-Ryerson electrometer measures the voltage developed by the memory cell as it is heated through the Curie temperature. From the voltage indicated on the electrometer

the remanent polarization may be calculated by Equation [5]. The sensitivity of this instrument is an important factor if small values of polarization are to be measured. Thus the capacity of the input of the electrometer (C_x/C load) should be kept small when small values of polarization are to be measured.

6. Oven. The heat developed by the oven randomizes the polarized memory element. A 1-inch diameter alundum-tube oven is used for the heat bath. One end of the tube is sealed with a teflon stop; the other end is open to receive the sample condenser. During randomizing, temperature is maintained constant at 140 degrees Centigrade. Provision is made in the stop for a thermometer to measure the temperature of the tube interior.
7. Specimen condensers. The condensers are permanently mounted on individual holders consisting of two wire arms -- one fastened to each end of an insulating mounting block by machine screws. Condenser leads are soldered to the supporting arms. The insulating block is held temporarily in a socket while electrical contact with the BaTiO₃ specimen condenser is effected by snap-spring terminals. (See Figure 4).
8. Switch. S_1 is a single-pole switch. If the electrometer is used to measure the polarization, S_1 is open in order to prevent the impedance of the pulser from being placed across the specimen condenser.

Grouping of Specimen Condensers

For the purpose of investigating remanent polarization of BaTiO₃ material as function of amplitude and duration of applied field, as well as for obtaining data on decay of polarization with time, fifty-three (53) condensers were prepared from the same sheet of Type X18 ceramic. During the preliminary measurements it was observed that the condensers varied widely in sensitivity although they were made from the same ceramic sheet. This indicated a need for determining some type of relative sensitivity measurement which would permit the selection of specimens with approximately equal ability to retain polarization. A "standard test", designed to give reliable reproducibility, was therefore devised. In the standard test the condenser was subjected to a 500 volt--500 microsecond d-c pulse, after which it was immediately randomized in the heat bath and measured for remanent polarization. The units assumed for this standard method of comparison are completely arbitrary; the method was intended to provide, as a first approximation, means for selecting condensers with approximately equal relative sensitivities.

Three groups of condensers were chosen for investigation. Capacities and "standard" sensitivities for the three groups are given in Table I.

Remanent Polarization Curves

Figure 8 shows representative curves of remanent polarization as a function of applied pulse voltage for several values of pulse duration. Data for these curves were obtained experimentally using condensers from Sensitivity Group 3. The remanent polarization coordinate of each plotted point

in Figure 8 was obtained by averaging four measurements in which applied pulse polarity was alternately reversed. Thus, average remanent polarization of two complete "flip-flops" was taken to be the remanent polarization corresponding to the voltage of the applied pulse. Since the thickness of the condenser dielectric was known (11 mils) the field could be computed. Breakdown voltages are indicated by the change of solid lines to dashed lines, at about 950 volts or 37,000 volts per centimeter. This breakdown voltage is high compared to straight d-c breakdown voltage; this may be attributed to the fact that short pulses were used in the measurements.

These investigations established the fact that strong remanent polarizations in highly oriented barium titanate can be produced by single pulses in the microsecond range. The limiting factor in the time domain was not the response of the material but rather that of the instrumentation in use.

Decay Curves

Figures 9 and 10 show decay of remanent polarization with time for various pulse durations. Each curve represents measurements made on condensers from the three sensitivity groups for given values of pulse duration. Coordinate data for the curves were experimentally determined as follows:

1. All condensers of the three groups were subjected to 500-volt pulses for a given pulse duration.
2. Measurement of remanent polarization was made on one condenser from each group for each time lapse shown.

Thus three condensers, one from each group, were measured for remanent polarization at only one coordinate value of elapsed time.

Figure 11 shows decay of remanent polarization with time as a function of applied field, and indicates that even very low values of remanent polarization are stable for long periods of time.

It may be observed that these curves of loss of polarization with time are collectively and systematically associated in trend. The irregularity is thought to be due to random distribution of crystal grain orientation (Figure 3); the crystal grains are also clamped in different ways by the surrounding BaTiO₃ ceramic, with the result that the corresponding wall energies modify the total energy obtained when the dielectric is randomized.

However, the decay curves show conclusively that the polarization, following an initial loss during a short period immediately after pulsing, remains relatively constant for a very long period of time. Some of the test condensers were observed to have approximately 5,000 cgs units of remanent polarization even after three months.

Further work in progress will include:

1. Continuation of a study of decay of polarization in the 0 to 100-volt range with pulse durations ranging from 0.1 to 10 microseconds.
2. Construction of new instrumentation for measurement purposes.

Ferroelectric Bistable Circuit Elements

Results of this research have shown that ferroelectric materials may be used in small, inexpensive bistable circuit elements which possess good memory properties and high speed operation.

The dielectric hysteresis curve for BaTiO₃ shows that remanent polarization has two opposite limiting values. Switching of polarization from one limiting value to the opposite limiting value by an external field may be described as a molecular snap action and corresponds to the "flip-flop" operation desired in computing circuits. Because of this property the possibility of designing different computer circuit elements using ferroelectric material has been investigated.

Figures 12 and 13 show the basic circuit of a memory flip-flop element employing ferroelectric condensers. Figure 12 illustrates the use of an inductance and a resistance for load impedance. Figure 13 shows resistance-capacitance load impedances. Any type of series impedance may be used, selection being governed by type of circuit with which the basic element is to be used.

Assume that remanent polarization of the ferroelectric condenser in the basic memory circuit is minus P_r . If a positive pulse of sufficient amplitude is applied to the input terminals, the remanent polarization of the dielectric will be switched from minus P_r to plus P_r , causing a large displacement current to flow through the series load impedance. If a negative pulse is applied to the input terminals, the displacement current will be small, since the remanent polarization has the same sign as the applied pulse and no switching occurs. Thus the basic circuit element is capable of responding to pulses of predetermined polarity or of remembering the polarity of the pulse previously received. Such is the basic requirement of a counter or memory element.

For purposes of illustration simple types of indicating circuits are shown in Figures 12 and 13. A gas discharge tube, biased close to its ignition potential, is placed across the series load impedance. If an applied pulse causes switching of remanent polarization, the voltage drop across the series load impedance, caused by the displacement current, ignites or extinguishes the gas discharge tube depending upon polarity of the bias, direction of the displacement current, and initial condition of the gas discharge tube. Figure 13 is given to illustrate how a bistable transistor indicator circuit can be used to indicate the state of the ferroelectric "flip-flop."

These basic circuits have been tested and one microsecond operation obtained.

Ferroelectric Memory Matrix

In general it is assumed that memory properties must be inherently connected with sufficient nonlinearity to obtain simple switching of storage

elements in a matrix type of memory device. This was the case when magnetic materials with rectangular hysteresis loops were proposed for digital information storage (4, 5, 6).

This same idea prevailed when BaTiO₃ single crystals, with rectangular hysteresis loops, were first suggested for use in a simple electrostatic memory matrix (7, 8). Figure 14 represents such an (n x n) ferroelectric memory matrix proposed at the beginning of this work. Without going into detailed discussion, it may be seen from the reduced matrix diagram of Figure 14 that the selected condenser, of capacitance C_{xy} , will be acted upon by the applied voltage V, while the groups of condensers connected to the leads x and y, of capacitance $(n - 1)C$, will be acted upon by a voltage somewhat less than V/2. Condensers located in the remaining part of the memory plane, of capacitance $(n - 1)^2C$, also produce a voltage drop; however this voltage drop is practically negligible. Thus the familiar 1:2 voltage ratio is obtained in the matrix. This ratio may be improved to about 1:3 by applying an electrostatic compensating potential to the unused rows and columns of the matrix.

Although it seemed that a memory matrix using single crystals would be a more simple arrangement, the favorable memory properties found for highly oriented ceramics suggested their use in a memory matrix even though this would present a more complex problem. The only disadvantage of ceramic material is the lack of "proper" non-linearity; that is, the lack of sharp breaks in the polarization characteristic curve.

However, it should be noted that a nonlinearity "sufficient" for the switching of the storage elements can be obtained by using a switching matrix with a high selection ratio. Remanent polarization curves shown in Figure 8 indicate that the relation between remanent polarization and applied field is approximately exponential as should be expected; this particularly so in the low voltage region. This exponential relation was also found by transient measurements (9). After recognizing this fact, it was decided to develop a switching matrix having a selection ratio of 50 or more. Since ferroelectric memory cells are voltage devices, the switching matrix should also be a voltage device. In such a matrix the switching and memorizing action would essentially be separated.

For illustration purposes assume a selection ratio of 50 and a simple square law relating remanent polarization and applied field. Further, assume a pulse which established a remanent polarization of about 1250 cgs units. It can now be seen that the disturbing polarization on the unselected matrix cross-points would be only 0.5 cgs units, a value well below the threshold of any remanent action in a highly oriented ceramic. Such a low level threshold should exist although no reliable measurements are yet available.

Principle of the High Selection Switching Matrix

The selection ratio in a switching matrix may be defined by the ratio of the potential acting on a selected cross-point to the highest potential appearing on any of the unselected cross-points. The basic problem was to find a method for compensating practically all disturbing potentials which

appear on the unselected matrix cross-points. Many possible matrix combinations were systematically studied until a switching matrix using diodes as nonlinear elements was found which was capable of a high selection ratio.

Figures 15 and 16 illustrate schematically the principle of this new type of switching matrix. Figure 15 shows one cross-point; x and y represent one row and one column respectively and are connected through the resistors R_M to diodes D_1 and D_2 . The diodes D_1 and D_2 are alternately connected through the corresponding switches to ground depending on whether writing or reading is desired. These switches, which may also be diodes, are common to all D_1 and D_2 diodes respectively. For a simple presentation, the usual switch symbols have been used in both Figures 15 and 16. The active diode in the cross-point is biased through the resistor R_C with a positive or negative potential, polarity depending on whether writing or reading is desired. C_F represents the ferroelectric memory cell. It should be noted that any other bistable element may also be used as a memory element such as a bistable transistor circuit, etc. R is the load impedance common to all memory cells; it may be a pulse transformer, integrating condenser, etc. A diode may be connected across the load impedance to act as a low resistance path during the writing period (Figure 16). The writing and reading steps are similar except for the polarity of the bias and the polarity of the applied pulses.

Operation of the selection matrix may be described as follows. For the writing cycle, diode D_2 at each matrix cross-point is biased in the forward direction (conduction) while diode D_1 is inoperative. If now a single negative pulse arrives at an unselected cross-point and the pulse amplitude appearing across the diode is slightly less than the bias voltage V_C , the diodes remain in a high conducting state. The potential drop across C_F is practically negligible due to low forward resistance of diode D_2 (about 70 ohms). On a selected cross-point two pulses coincide and drive diode D_2 into a low conducting state; a major part of the input pulse is now applied across the memory cell and switching action takes place. Thus the disturbances due to noncoincident pulses of amplitudes below the bias voltage are practically eliminated.

The selection ratio S_r may be computed from the expression:

$$S_r = \alpha X \quad [6]$$

X is a function of the operating point and characteristic curve of the diode and is defined as the ratio of the dynamic resistance of the diode in the low conducting state (high resistance) to the dynamic resistance in the high conducting state (low resistance). The term α contains the circuit parameters and is a function of the number of coordinates (coincidences) used. Due to the inherent symmetric conditions of the matrix all resistances are assumed to be equal; the pulse amplitude and bias voltage are also chosen to be nearly equal. Using these assumptions and the additional assumption that,

$$R + r \approx R,$$

α for a double coincidence matrix is given by

$$\alpha = \frac{2}{1 + \frac{3X\mathcal{P}}{R} + \frac{2X^2\mathcal{P}^2}{R^2}} \quad [7]$$

where \mathcal{P} is the dynamic resistance of the diode in the high conducting state (low resistance), and R is the value of the resistance connected to the matrix cross-point.

From this description it can be seen that triple, or higher order, coincidence memory matrices may be built, employing similar compensation. The dashed line in Figure 15 shows a three-dimensional matrix cross-point; perpendicular to the rows and columns a third switching conductor z has been added and connected through a resistor R_M to the cross-point. Triple coincidence on a cross-point is now needed for switching, enabling a random selection in three dimensions. Reading and writing operations are accomplished in the same manner as for the two-dimensional matrix.

The scanning devices are not shown since such circuits have already been described (10, 11); multicoincidence scanning switches may also be built on the principle described here.

Figure 16 illustrates schematically a two-dimensional matrix. The selection rows and columns are drawn with thick lines. The bias source for compensating the matrix is common to all memory cells and may be supplied in form of a long duration pulse; likewise the output is also common for all memory cells. Diode D_1 may be omitted and on each cross-point only one diode may be used. In this case in order to obtain a binary yes from the unswitched cross-points and a binary no from the switched cross-points, the reading step may be as follows:

1. The output comprises an anti-coincidence circuit, which combines in a bridge circuit a reading and signal pulse.
2. The same polarity pulses may be used for reading as for writing.
3. The stand-by condition may be reset by applying a reverse polarity bias pulse.

The equivalent circuit for the matrix in Figure 17 shows clearly that the impedance of all unselected cross-points connected to the selection rows or columns can be regarded as grounded. Thus the input resistance of a selected row or column will be primarily a parallel combination of the resistances of the unselected cross-points.

Figure 18 is a photograph of a working model of a 4×4 matrix of the type described. The diodes are type 1N56 and the resistances are 10,000 ohms.

Figure 19 shows the selection ratios obtained with operating conditions; however these curves do not represent optimum conditions but show merely preliminary results. It is clear from these curves that for each value of the compensating bias there exists an optimum applied pulse voltage corresponding to the highest selection ratio. The solid lines indicate the useful pulse

amplitude on a selected cross-point as a function of applied bias and selection ratio.

The switching and memory matrix presented is only one of many possible applications of ferroelectrics in the computer field but it shows the potentiality of this new material.

Work extended on a three-dimensional memory matrix and other computer applications of ferroelectrics will be reported later.

Acknowledgment

The work here reported has been done with the financial support of the USAF Office of Air Research under Contract AF18(600)-106, E.O.R. - 468. The author wishes to thank Professor Frank A. Biberstein for his kind cooperation and for the enthusiastic assistance of Mr. George E. McDuffie, Jr. and Mr. Richard W. Young, members of the staff of the Electrical Engineering Department. The author also wishes to thank Dr. Jean S. Mendousse for the valuable discussions during this work and to acknowledge the assistance given by Mr. Louis Peselnick who assisted at the beginning of this project.

Bibliography

1. Charles F. Pulvari, "An Electrostatically Induced Permanent Memory." Journal of Applied Physics, Vol. 22, No. 8, pp. 1039-1044, August 1951.
2. A. von Hippel, "Piezoelectricity, Ferroelectricity and Crystal Structure." Zeitschrift für Physik, Bd. 133, S. 158-173, 1952.
3. W.P. Mason, B.T. Matthias, The Physical Review, Vol. 79, pp. 1622-1636, December 1948.
4. Gay W. Forrester, "Digital Information Storage in Three Dimensions Using Magnetic Cores." Journal of Applied Physics, Vol. 22, Jan. 1951.
5. William N. Papian, "Coincident Current Magnetic Memory Unit," Master of Science Thesis, M.I.T. Elec. Engr. Dept., 1950.
6. Jan A. Rajchman, "Static Magnetic Memory and Switching Circuits." RCA Review, June 1952.
7. Charles F. Pulvari, Air Force Project Report No. 4, Air Force Contract No. 33(038)15977, George Washington Univ. Oct. 1950-Oct. 1951.
8. J.R. Anderson, "Ferroelectric Material Storage Element for Digital Computers and Switching Systems." Bell Telephone Laboratories.
9. Dudley A. Buck, "Ferroelectrics for Digital Information Storage and Switching." Report R-212, M.I.T., June 1952.
10. C.B. Tompkins, J.H. Wahelin, W.W. Stifler, Jr., "High-speed Computing Devices." McGraw-Hill Book Co., 1950.
11. J.H. Felker, "Typical Block Diagrams for a Transistor Digital Computer." Electrical Engineering, Dec. 1952.

Table 1

Condenser groups and their "standard" sensitivities.

Group No.	Capacitor No.	Capacity,	Sensitivity: P_r in cgs.
1	4	154	4200
1	5	169	4280
1	8	167	4510
1	9	167	4480
1	11	166	3990
1	27	124	4370
2	2	191	8520
2	19	107	8900
2	20	212	9300
2	24	174	8920
2	60	116	7650
2	65	126	10,580
3	22	134	21,900
3	33	238	22,000
3	41	250	22,200
3	44	171	22,000
3	48	208	21,900
3	55	152	21,900

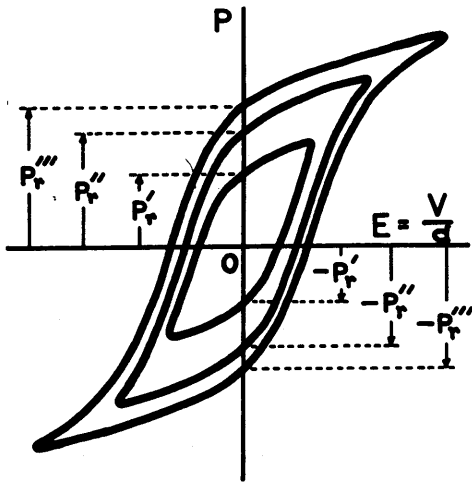

Fig. 1
Hysteresis curves obtained by different maximum values of electric fields.

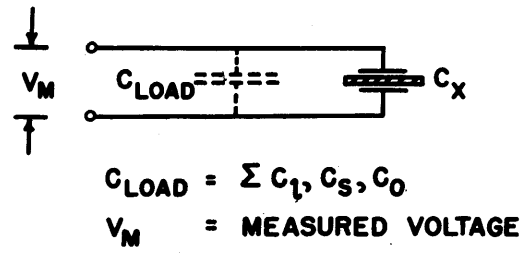

Fig. 2
Equivalent circuit of remanent polarization measuring apparatus.

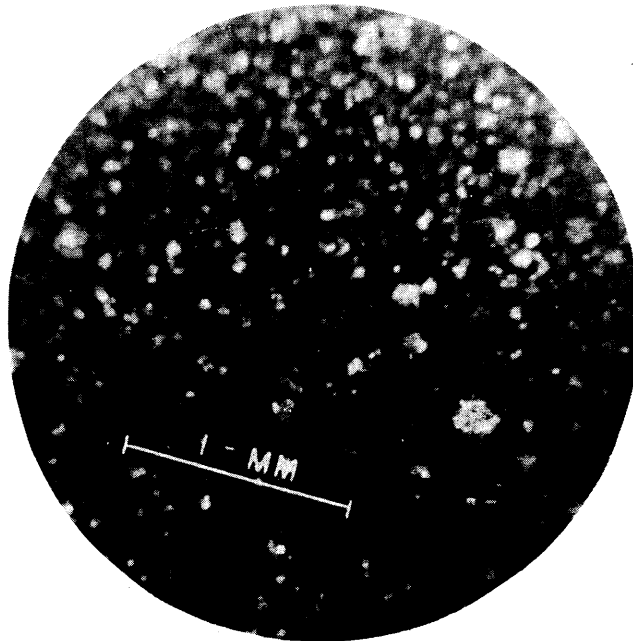

Fig. 3
Photomicrograph of a thin sheet of ferroelectric Glenco ceramic.

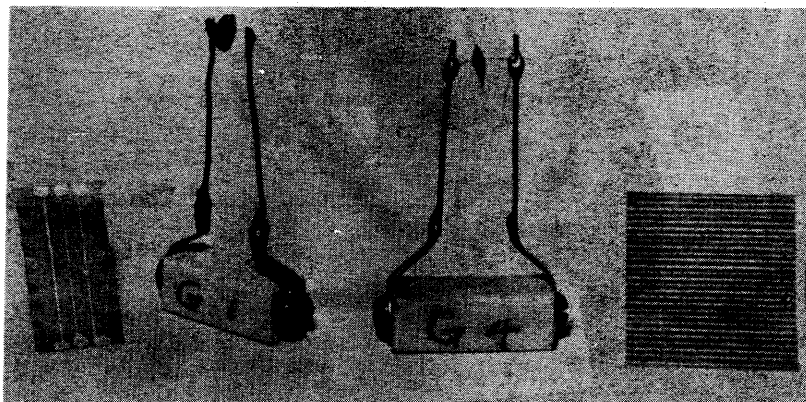

Fig 4 - BaTiO3 specimen condensers.

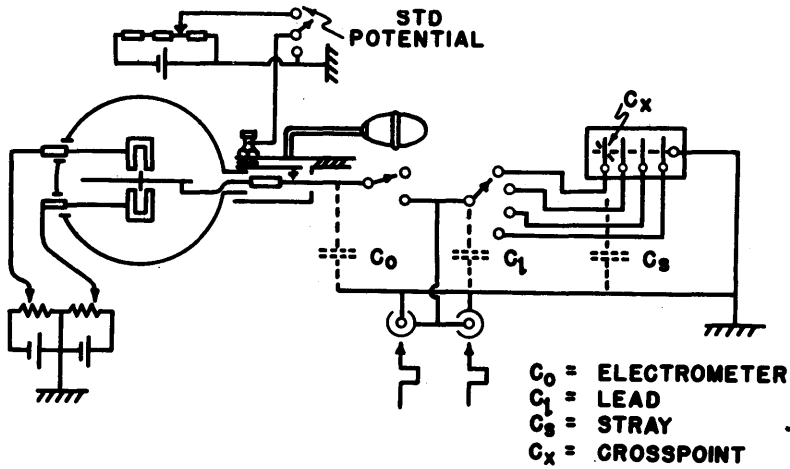

Fig. 5
 Arrangement for obtaining data on remanent polarization.

Fig. 6
 Block diagram of the experimental set up for measuring remanent polarization.

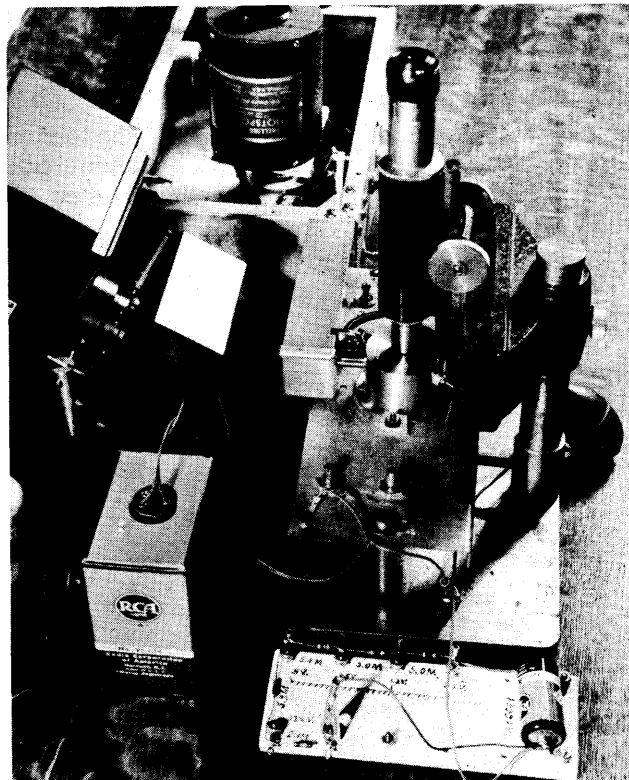
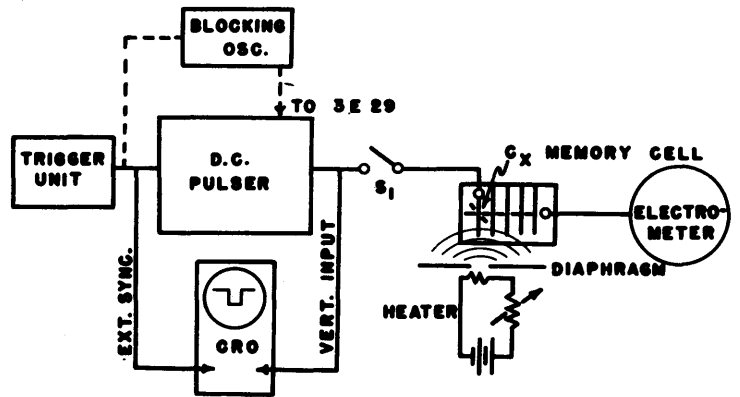

Fig. 7
 The experimental apparatus.

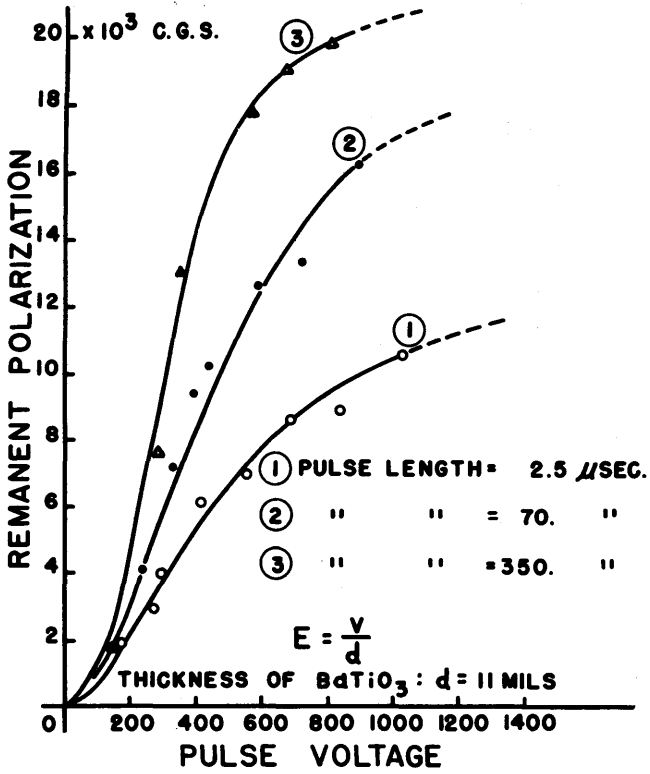

Figure 8 Remanent polarization curves.

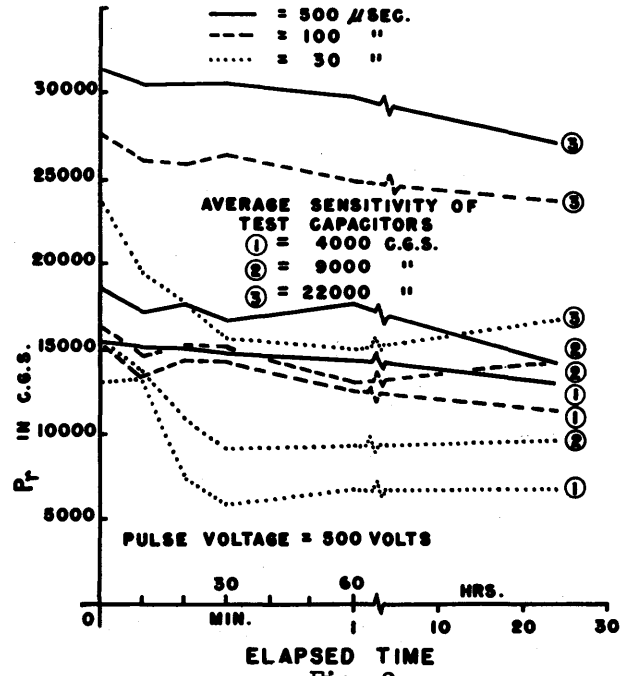

Fig. 9 Decay of remanent polarization in function of pulse duration.

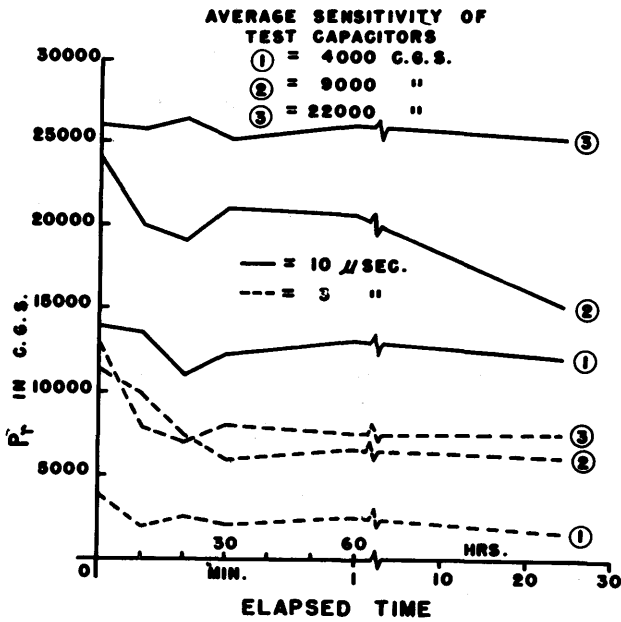

Fig. 10 Decay of remanent polarization in function of pulse duration.

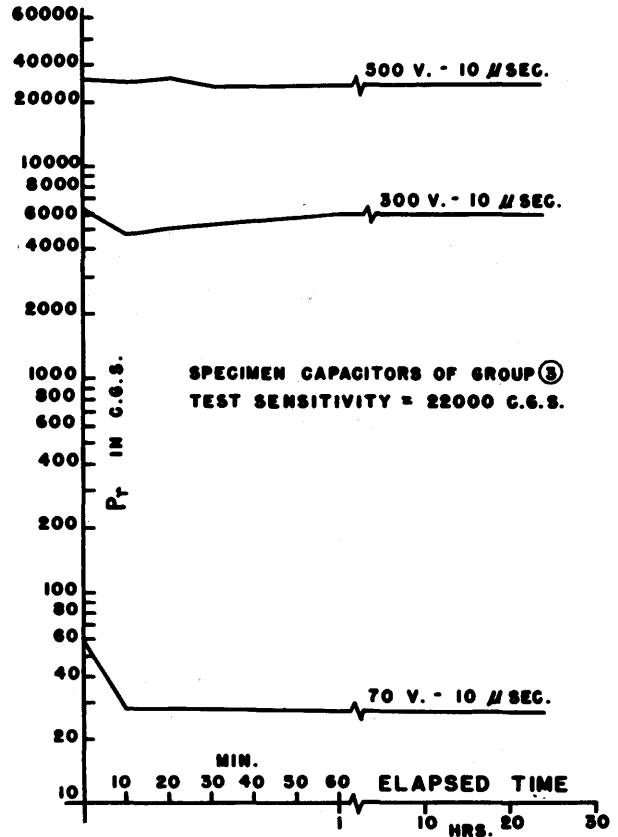

Fig. 11 Decay of remanent polarization in function of applied field.

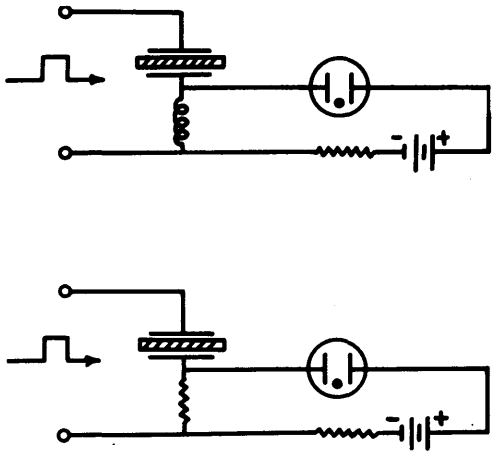

Fig. 12
Bistable ferroelectric circuit elements.

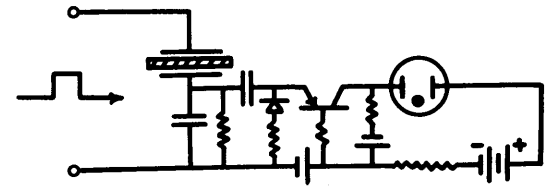
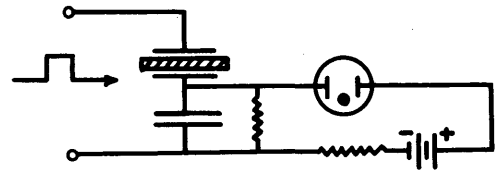

Fig. 13
Bistable ferroelectric circuit elements.

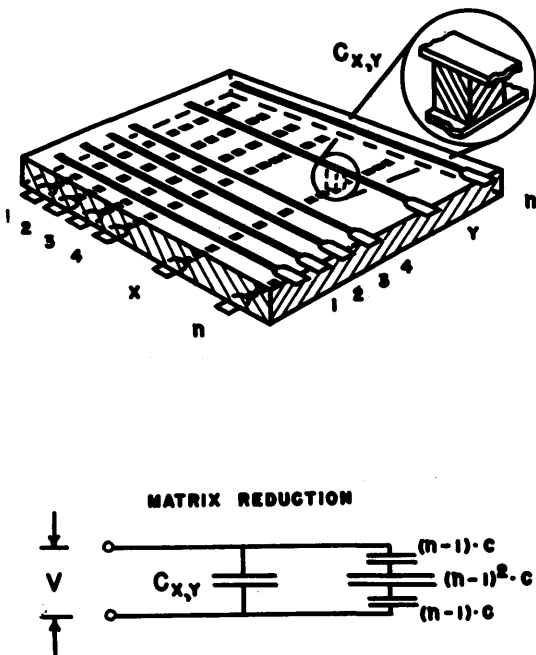

Fig. 14
Memory matrix on a single crystal ferroelectric plate.

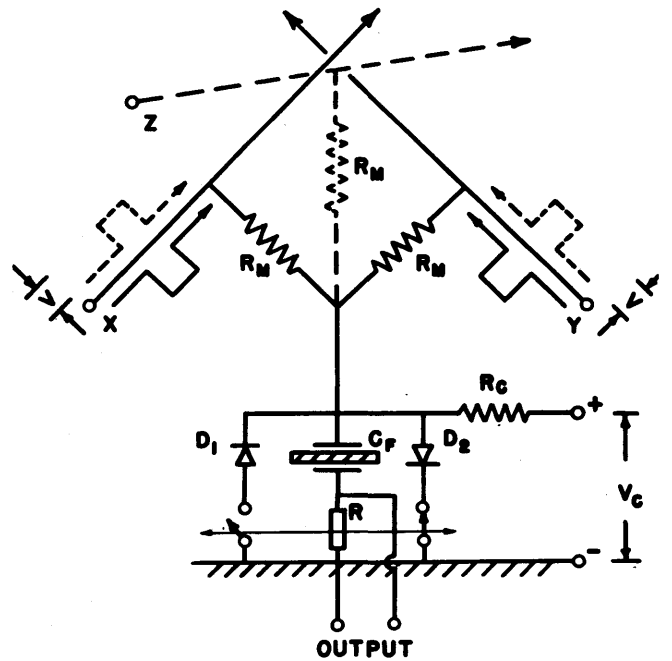

Fig. 15
One cross-point of the high selection switching and memory matrix.

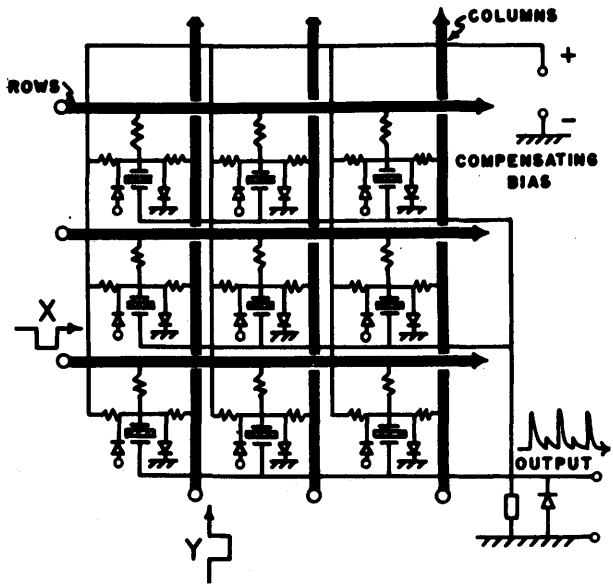

Fig. 16

Double coincidence memory matrix with compensated matrix disturbances.

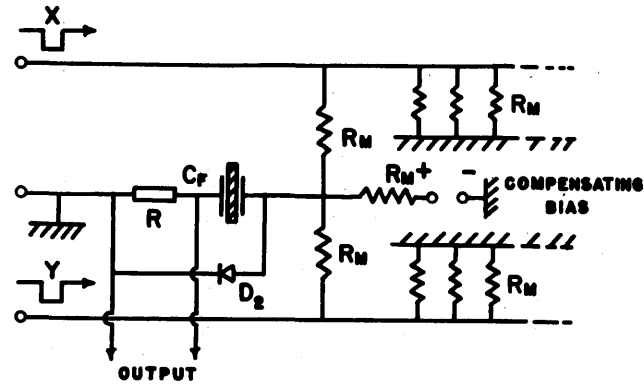

Fig. 17

Equivalent circuit for matrix shown in Figure 16.

15T

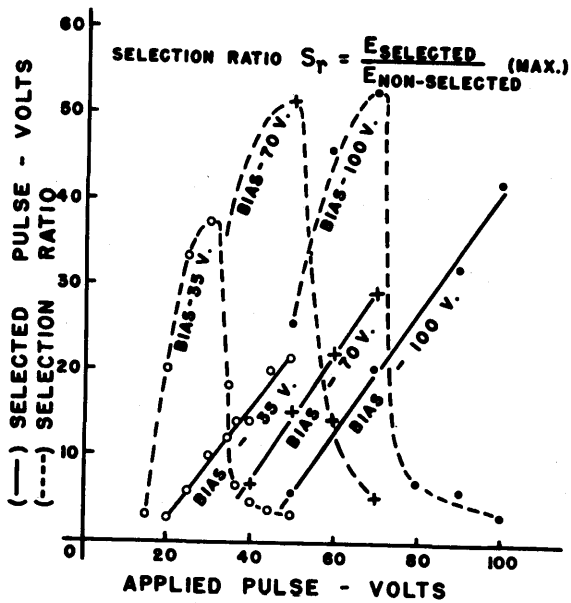

Fig. 18

Model of matrix shown in Figure 16.

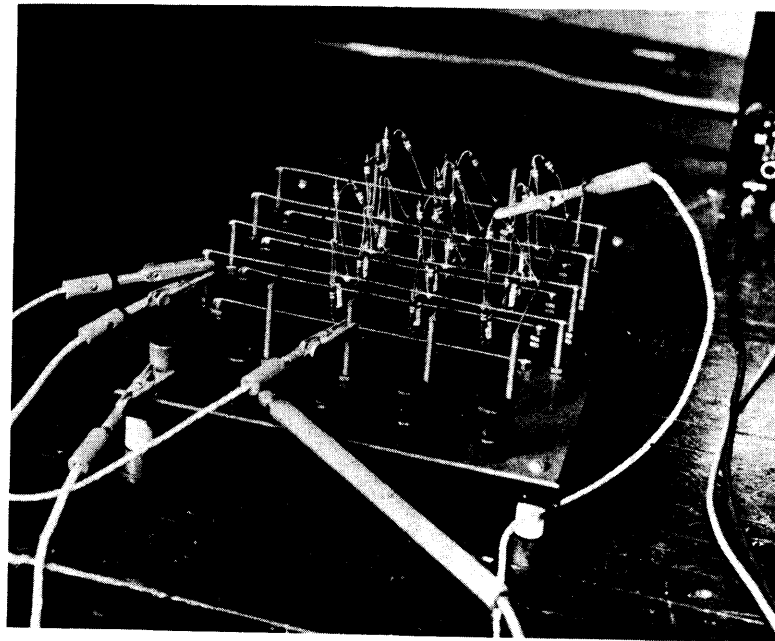

Figure 19

Selection curves.

MAGNETIC REPRODUCER AND PRINTER

by John C. Sims, Jr.

Remington Rand Inc.,
Eckert-Mauchly Division.

The rapid development of business systems during the past few years has at the same time called attention to some rather serious limitations in mechanical and photographic methods for the production of printed copy. Modern electronic computing machines can process data and produce results in tremendous quantity. Moreover, the operation of large business organizations creates a problem in the dissemination of information within themselves that is not always economically solved by existing equipment.

There has accordingly been much interest in new methods of producing printed copy, both for the recording of original data created by computing processes and for multicopy reproduction of existing data for distribution. The technical literature (1) reveals that considerable development work has been done on equipment of this type in the last few years. Devices have been designed for rapidly recording the results produced by electronic computers. These devices have, for the most part, been improvements and extensions of well known mechanical principles. The inherent speed limitations of mechanisms have generally been overcome by utilizing a high degree of parallelism. For example, printing tabulators may employ upwards of one hundred independent printing units, each capable of printing the entire font of symbols it is desired to record (2). These parallel or "gang" printers have utilized relief type mounted on reciprocating bars or rotating wheels. Means are then provided to bring the paper and the type into engagement when the desired character is in position in each column. The large amount of equipment involved, not only in one hundred or more printing stations, but in the devices required for storing information and feeding it to them, results in a bulky and expensive piece of gear.

The subject of this paper is a printing process and equipment which is inherently fast enough so that serial printing methods can be used and still permit reasonable speeds to be attained. The process depends on the attraction of a magnetic ink to selectively magnetized areas on a printing plate. Setup of the printing plate is rapidly accomplished by magnetic recording techniques while development and transfer of the recorded image to paper is effected at printing press speeds. This process we have generically named "Ferrography," a title which has also been used by more independent investigators of the art (3).

The Ferrographic process, like the older printing methods, is fundamentally one having three steps: first, the recording of a magnetic printing plate by one of several methods; second, the inking of the plate to develop the latent magnetic image; and third, transfer of the developed image to paper or other receiving surface. The process is thus fundamentally similar not only to the Xerographic electrostatic process (4) but to all commonly used printing methods. The differences lie in the type of materials employed for the printing plates, the methods used for registering images on them and techniques for inking or developing the images. Processes generally transfer the image to paper by

pressure contact, but some require preprocessing or postprocessing of the paper.

The first step in the Ferrographic process is the recording of a latent magnetic image on a magnetizable drum or plate. A number of materials have been used successfully for Ferrographic plates. These include iron oxide dispersions, electrodeposited films of cobalt-nickel alloys and sheets of magnetic alloys such as Cunico and Cunife. It is important that the material chosen has as high an energy content as is consistent with the definition desired and practical recording head design. Strong magnetic images can be readily inked while weak ones produce "noisy" prints.

There are a number of ways in which magnets can be impressed on a magnetizable surface. Perhaps the most commonly used method of recording is called longitudinal, in which the magnets are oriented parallel to the motion of the recording head. This method is used on sound recorders and on most pulse recording equipment. For recording on Ferrographic plates, however, the magnet orientation produced by longitudinal recording is the least suitable. The magnets produced on the surface of the plate by a longitudinal head tend to produce only outlines of desired images. It will be recalled that the flux path or magnetic "ghost" of a bar magnet can be revealed by laying a piece of paper over the magnet and then sprinkling iron powder on it as shown in Figure 1. It will also be remembered that the flux pattern so developed consists of heavy agglomerations of powder at the poles of the magnet and progressively lighter powder deposits at more remote distances, even along the magnet itself.

The same phenomenon occurs on a developed Ferrographic plate. The magnetic ink is attracted only to magnetic poles on the plate and not to intermediate points as shown in Figure 2a, even though the material at these points is magnetized. This means that if a video signal is applied to a longitudinal magnetic head which is scanning a plate, then the ink will develop only the outline or flux changes of the recorded image. A true picture will be developed only if the head records a modulated carrier which will apply a series of poles to surfaces which must attract ink. The result of recording such a series of poles is shown in Figure 2b.

Two other recording methods exist which do not require such a carrier. These methods are commonly called perpendicular and transverse recording. In the first method, shown in Figure 3, magnets are recorded which are oriented normal to the surface of the plate. In the second, the magnets are in the plane of the plate but at right angles to the motion of the recording head.

The simplest type of perpendicular recording head, as shown in Figure 4a, consists only of a pencil shaped bar of soft magnetic material having a coil wound on it for the reception of video signals. If the point of such a recording element is brought in contact with, or slightly spaced away from, a Ferrographic plate, then the high flux concentration at the point as a result of current flowing in the coil, will mark the plate magnetically. The flux returns through the air to the far end of the bar. This is, of course, an inefficient magnetic structure and can be improved by providing an iron return path for the flux. The area of the return bar should be large compared to

that of the pencil point of the marking bar or the plate will also be marked at the flux return point. Such an arrangement is shown in Figure 4b.

Of course, a recording head which impresses purely perpendicular magnets, or for that matter longitudinal, or transverse, is a theoretical possibility only. The magnetic flux lines emanating from a point or developed across a gap always fringe out in broad curves which result in magnetic components in all three axis. Thus, for example, perpendicular heads produce some recording both transverse and longitudinal. The transverse component becomes larger if a return bar is brought down to the surface of the Ferrographic plate and becomes the primary component if the return bar is brought to a point and located close to the marking bar point.

Now the important criteria in recording on a Ferrographic plate is the creation of poles. It will be recalled that longitudinal recording of a video signal was unsuitable because of the small number of poles produced. The deficiency could only be corrected by modulating a carrier so that enough poles would be produced to effectively attract ink to dark areas. Perpendicular recording overcomes this objection by rendering such a surface a large pole as a result of the orientation of the magnets produced. Noticeable wash-out in the center of large areas will still be encountered, however, due not only to self demagnetization over the surface of a large pole but also to the lack of magnetic gradients on the surface.

It has been found that transverse recording has none of these shortcomings. The magnetic pattern produced in an area which is recorded to print dark will resemble a ploughed field where the head has scanned across it as shown in Figure 5. Strong flux lines fringe out from the plate to join the crests and valleys of each furrow. The magnetic gradients are sharp and the magnetic return paths in air are short to give strong external fields. Ink powder is attracted strongly to such a surface. No modulated carrier is required for the driving signal and thus the circuits required are simpler.

Several problems exist in the formulation of inks suitable for Ferrographic printing. In the first place, the ink must be strongly attracted to the magnetized areas of the plate. They must, therefore, have a high initial magnetic permeability. The attraction and adherence of the ink depends on its providing a better or lower energy flux path than air. Almost any magnetic powder satisfies this criteria but soft magnetic materials are superior to hard ones from the point of view of permeability.

The ink may be either a liquid or a powder. Successful printing has been done with each type. Liquid inks usually consist of unstable colloidal dispersions of iron powder or iron oxide powder in a low viscosity fluid. Such an ink is a dispersion of Fe_3O_4 in alcohol or carbon tetrachloride. A Ferrographic plate immersed in such an ink draws the magnetic material from solution to adhere to the magnetized portions of the plate. Similar liquid inks can be made with soft iron powder of Fe_2O_3 . In each case the vehicle should be colorless and have a very low viscosity. High viscosity vehicles do not permit sufficient mobility of the magnetic particles and, of course, colored vehicles stain the plate.

The image so developed can be transferred at once while still wet or can be

dried before transfer. In the latter case, of course, the vehicle should be highly volatile. When wet transfer is made, smearing of the image and loss of definition result unless an offset technique is used.

Dry inks can be made from mixtures of magnetic powders with pigments, dyes and fixing resins. These inks can be applied to a spinning Ferrographic cylinder to develop an image. One feature which distinguishes Ferrography from other printing processes is that, although inks are attracted to selected areas, there is no magnetic mechanism to repel them from unselected portions of the plate. In Xerography, for example, there is some repulsion as well as attraction of charged ink particles. Relief printing plates effectively deny adherence of ink in low areas, while Lithography is essentially a negative process, depending for its operation entirely on inhibition of ink adherence on wet portions of the plate.

One mechanism which has been used successfully in Ferrography to deny adherence in unselected portions is centrifugal force. This technique works satisfactorily with dry powder inks. Cylindrical plates are used and rotated rapidly during inking. The ink is poured on the top of the spinning cylinder and centrifuges off the unmagnetized portions. In this manner, plates can be inked so that unselected areas are extremely clean.

After the image has been developed by inking, it can be transferred to paper by pressure contact. If liquid inks are allowed to dry partially, then they will transfer to paper on contact without smearing. Similarly, dried liquids inks and dry powder inks can be contact transferred to a dampened sheet of paper. If this is done, almost complete transfer of the developed image will be accomplished. A pressure sensitive adhesive on the surface of the paper will also effectively strip the image. It also serves the function of holding or fixing the ink particles to the paper surface.

Three other methods of fixing the image have been used. The first is to include in the ink formula a soluble adhesive resin. The paper is then dampened with its solvent as a stripping agent which also softens the adhesive to fix the image. The second method incorporates a thermo-setting resin or wax in the ink formula. Application of heat from an infrared lamp after transfer then fuses the image to the paper surface. In addition, dyes can be included in the ink formulation which are soluble in the solvent and which will mark the paper surface to increase the intensity of the print or produce some desired color. The iron powder can then be magnetically removed from the paper surface so that only the dye pattern remains.

The third fixing method is to spray the paper surface with a fixer such as is used on charcoal or pastel drawings. These fixers are usually thin shellacs or lacquers. The fixer also imparts to the paper a superior finish or gloss and also tends to prevent ink dyes from fading.

The Ferrographic process has been employed in the design of a duplicating machine. This equipment produces Ferrographic duplicates of copy up to 8½ by 13 inches. The material to be duplicated is facsimile scanned by a photocell while a magnetic head receiving the signals sets up a Ferrographic plate. This plate is cylindrical and, after development by a dry powder ink, the image is transferred to paper and fixed.

The process has also been studied for use in a high-speed-data printer. Here two methods of application have merit. One method employs a multi-channel head to receive and record parallel facsimile signals to create images of character shapes on a Ferrographic drum. The other employs direct magnetic transfer from a type face.

Multichannel heads for use in the first process have been produced having upward of one hundred channels per inch. Such a head structure is shown in Figure 6 and 7. These heads can be fed from a letter forming function table or switching circuit through an electronic distributor to record character images in response to an input in code. Preliminary tests show recording speeds in excess of 10,000 characters per second with such a head. Since a single recording element can set up printing plates at these speeds, serial equipment becomes practical. This simplifies the design from a logical standpoint and reduces the amount of equipment required. The transfer to paper, of course, can proceed at printing speeds until the desired number of copies have been produced. The plate is then erased and new copy set up on it.

Direct magnetic transfer from soft iron type faces can also be done serially. The type faces can be mounted on one or more rotating wheels which are mounted on an axle parallel to the Ferrographic drum axle. A magnetic circuit is pulsed when the desired character is in position next to the drum to effect magnetic image transfer. The use of a plurality of such type wheels has been considered, both by the writer and by Berry (3), providing one wheel for each column of the copy to be produced. A single type wheel can be operated rapidly enough, however, to scan a drum surface at acceptable speeds with simpler circuitry.

The Ferrographic process has an economic advantage over many existing printing processes. This advantage is the use of ordinary sheet paper. Special stock is not required in most cases and carbon paper is eliminated. The high cost of pin-fed multipart forms represents a major part of the cost of operating tabulating equipment. Such a high speed printer can consume its own cost in paper in a year's time. This high cost is the result not of using very high grade paper but rather of the high cost of carbon paper, of interleaving it between the sheets of the form, punching the tractor holes along the side of the form and stapling the sheets together. Since such specially prepared papers are not required for Ferrography, a tremendous reduction in the operating cost of the equipment can be expected. High speed printing processes employing "teledeltos" or other electrosensitive papers are uneconomical for the same reason. These papers are very high in area cost and are not generally available.

The Ferrographic printing process appears to be superior to Xerography on several counts. First, the magnetic plate constitutes a memory for the information which is to be printed. The electrostatic charges which govern the operating of Xerographic printing are destroyed by each printing signal. They must, therefore, be restored by re-recording or recharging between printing operation. Secondly, the fact that a single recording suffices to produce a large number of copies is important from a legal point of view. The legal status of the carbon copy is well established. Microscopic examination of an original and a carbon copy can confirm that they were produced simultaneously in a printer or typewriter. The same relationship can be established for Ferrographic prints produced from the same recording. Supposedly identical

recordings of the same subject matter will differ in a microscopic sense due to magnetic noise on the plate and to minor defects in the operation of the recording process, which only such microscopic examination would reveal. Continuity of recording reflected in a family of copies can be obtained only by commercial printing processes, carbon copies and Ferrographic prints. They cannot be obtained by processes which require re-setup of the copy between printing operations such as is required in Xerography and facsimile.

In summary, the new process provides means for rapidly setting up copy on a printing plate. The information may be new data received in pulse code from a computer or facsimile signals generated by a photo scanner. The resulting printing plate can be developed and printed rapidly. As many copies as may be desired can be produced from a single setup. The plate can then be erased and new information recorded. It is believed that the process will be useful for tabulators and data printers as well as facsimile duplicators. The process is also expected to find application in commercial printing especially where setup time is an important economic factor.

REFERENCES

1. "Ferrography," Atkinson and Ellis, Franklin Institute Journal, November 1951.
2. "A Survey of Non-Mechanical Type Printers," Lt. R. J. Rossheim, USNR, AIEE-IRE-ACM Computer Conference, December 12, 1952.
3. "Ferromagnetography," T. M. Berry and J. O. Hanna, GE Review, July 1952.
4. "Xerography," The Haloid Company, Rochester, New York, 1950.

Fig. 1 FLUX PATTERN
BAR MAGNET

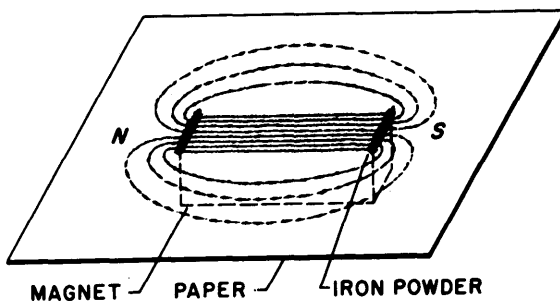

Fig. 2.a VIDEO SIGNAL
LONGITUDINAL MAGNETIC HEAD

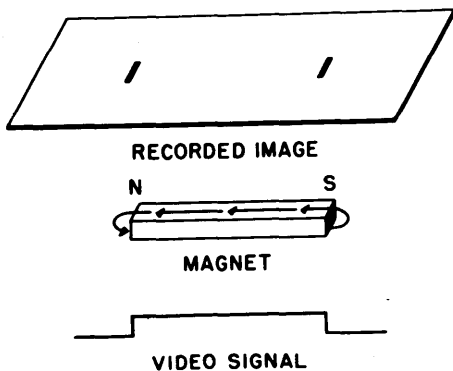

Fig. 2.b SERIES OF SIGNALS
LONGITUDINAL MAGNETIC POLES

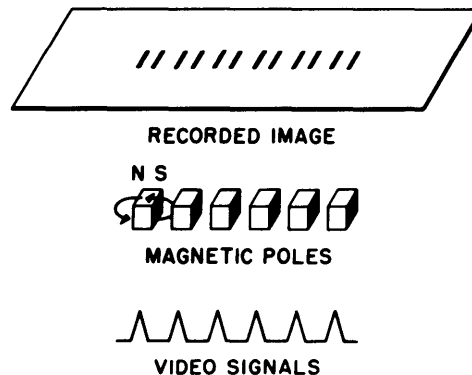

Fig. 3 PERPENDICULAR RECORDING HEAD

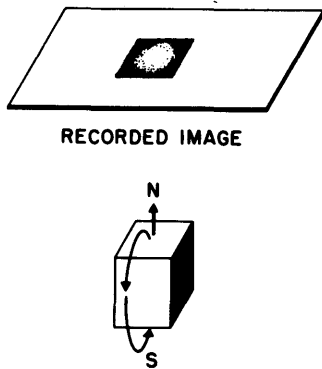

Fig. 4a PERPENDICULAR RECORDING HEAD

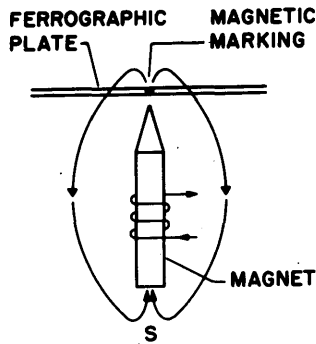

Fig. 4b PERPENDICULAR RECORDING HEAD

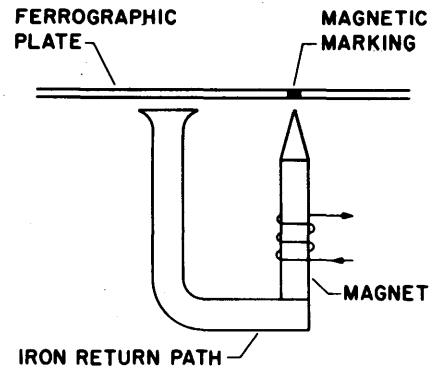

Fig. 5 TRANSVERSE RECORDING

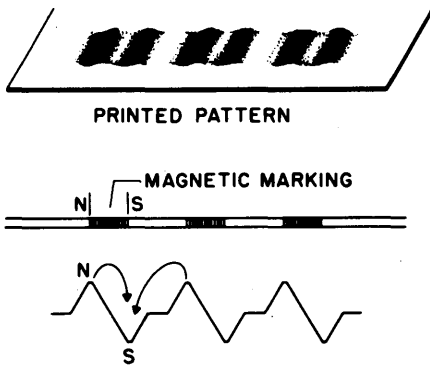

Fig. 6 MULTICHANNEL HEAD

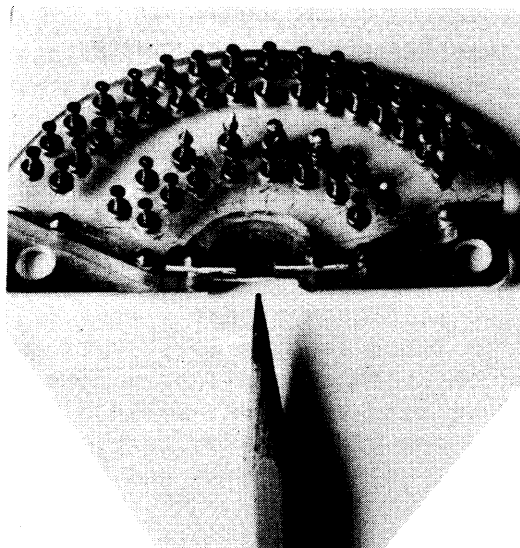
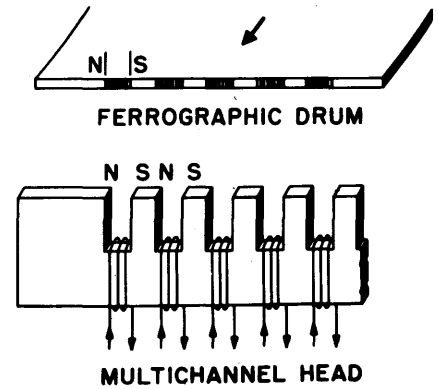

Figure 7

Photograph of Multichannel Head

An Improved Cathode Ray Tube Storage System*

by

R. Thorensen

National Bureau of Standards, Los Angeles

Introduction

Several years have passed since Williams and Kilburn⁽¹⁾ first described their method of storing digital information as charge patterns on the phosphor screens of common cathode ray tubes.

Since then many computers have been built using this form of storage. Considerable research has been carried out to further the understanding of the storage phenomena^(2,3) and to improve the storage tubes themselves. Yet this type of memory is still faced with two rather severe limitations. The first one is spot interaction or spillover. Thus if a single spot on the cathode ray tube screen is referred to repeatedly, the information in adjacent spots may be altered. A measure of the storage systems susceptibility to this type of failure is the "read-around ratio", or the number of times a single spot may be consulted before the adjacent spots have to be regenerated to avoid loss of information. Needless to say a low read-around ratio limits considerably the usefulness of a storage system.

The second type of difficulty encountered is caused by the presence of flaws or imperfections on the cathode ray tube screen, of such characteristics that they will not store information. These imperfections are usually very small even when compared with a beam diameter and it is relatively easy to position the charge pattern so that none of the flaws interacts with any of the storage spots. It is however quite difficult to maintain a high enough long term stability to insure that the raster of storage spots does not drift onto one of these flaws with a resultant loss of information.

The ability of the electrostatic memory tube to retain its information in the presence of flaws on the phosphor screen is somewhat dependent on the mode of operation of the tube.

Thus the various systems presently in use (dot-dash, double dot, defocus-focus, etc.) all show different susceptibility to flaws. As a rule, however, those systems which show a high resistance to flaws have a low read-around ratio and vice versa. Because of this, efforts to improve cathode ray tube storage systems have largely been centered on producing improved storage tubes with better focus and deflection characteristics and with storage screens free of flaws⁽⁴⁾.

A parallel effort has been carried out at the Institute for Numerical Analysis to devise a modification of the Williams' principle of storage which has resulted in improvements not only in spillover, but also in resistance to flaws. Before describing this new system, however, it is well to review briefly the principle of charge storage in the conventional dot-dash system both under normal operating conditions and as affected by spillover.

*The preparation of this paper was sponsored (in part) by the Office of Scientific Research, USAF.

The Dot-Dash Storage System

Normal Operation

The major components of a cathode ray storage system include the storage tube itself with a pick-up electrode in the form of a wire screen added to the face of the tube, an amplifier for the restoration of signal levels, and beam control and deflection circuits. The pick-up electrode is capacitively coupled to the phosphor screen inside the cathode ray tube so that sudden changes in charge distribution on, or in the vicinity of, the phosphor result in a transient voltage signal at the input to the amplifier.

Consider now how such transient voltage changes may be generated. When an electron beam of proper energy is directed at a specific spot on the phosphor screen, the area directly under the beam charges positively with respect to its immediate surroundings due to emission of secondary electrons.

After a short time interval an equilibrium potential distribution is reached somewhat like that shown in Figure 2. Under these conditions the number of secondary electrons arriving at the collector each instant just equals the number of primary electrons in the beam. After the charge distribution of Figure 2 has been established it will remain intact although the electron beam is turned off as the phosphor screen is an excellent insulator. If the beam is now turned on and off repeatedly, a signal like the one in Figure 3(C) is developed at the input to the amplifier.

The initial negative going portion is due to the appearance of an electron cloud in the vicinity of the pick-up screen when the beam is turned on, and the later positive going portion is due to the disappearance of this electron cloud when the beam is turned off. No changes take place in the charge pattern on the phosphor screen since an equilibrium potential distribution had previously been established at this spot. The times for the generation and disappearance of the electron cloud are extremely short so that the shape of the output signal is largely determined by the transient response of the amplifier.

Consider next what takes place when the electron beam is turned on and moved slowly, say to the right. The new areas which come under direct bombardment of the beam, charge rapidly to a positive equilibrium potential, and the positively charged areas which are emerging from under the beam will slowly be discharged by the capture of secondary electrons, to the average potential of the surroundings. Thus the resultant effect is that the potential peak at X moves more or less intact to the position Y as shown by the dotted lines in Figure 2. If the beam is again directed to position X and turned on, the equilibrium potential peak has to be re-established. This occurs very rapidly and for a while both the peaks at X and Y may co-exist. However, as the beam is kept on, the secondary electrons from spot X gradually discharge the potential peak at Y down to the average potential level of the surroundings. The signal developed at the pick-up plate during this sequence of events is shown in Figure 3(A). The initial going positive peak is due to the recharging of the spot X to an equilibrium potential and the following negative peak due to discharging of the neighboring positive surfaces at Y. The two signals shown in Figures 3(A) and 3(C) are those taken to represent a binary "one" and a binary "zero" respectively in this storage system. When sampled at the time indicated by the short pulse shown in Figure 3(B), the "one" signal is positive and the "zero" signal is negative.

Effects of Spillover

With the ideal signals as shown in Figure 3 it is hard to see how a "zero" could possibly be misinterpreted as a "one" or vice versa, and normally, of course, this does not happen. A difficulty arises however when the electron beam is repeatedly referred to a single spot on the cathode ray tube screen. Under these conditions the "dot" or "zero" signals of the adjacent spots are progressively altered as shown in Figure 4 (A, B and C). Actually there exists a continuous distribution of signals changing gradually from the ideal signal as shown in Figure 4(A) to the highly distorted form of Figure 4(C), depending on how often the action spot is referred to before the adjacent spots are regenerated. The signal shown in Figure 4(C) resembles a "dash" or a "one" signal very closely and certainly at the time of the inspection pulse the signal is positive. It would therefore be interpreted as a "one" instead of a "zero" and permanently changed to the "one" or "dash" type of a signal. Spillover has now taken place.

But what causes the "dot" signal to change its shape? The most plausible explanation is as follows: The ideal "dot" signal is due to the appearance and disappearance of an electron cloud in the vicinity of the pick-up plate as the beam is turned on and off. It is critically dependent on the fact that the area on the phosphor directly under the beam must previously have been charged up to an equilibrium potential (Figure 2). If this area has been fully discharged as in the case of the "dash" signal an initial positive instead of a negative going voltage is obtained.

The discharge of a positive potential peak is accomplished by its capture of secondary electrons from a nearby source; i.e., an electron beam is turned on in its vicinity. The emission of secondary electrons from any given area however is not sharply confined. Some of the electrons go to the collector while others tend to rain down on the most positively charged areas in the vicinity of the electron beam. Surely the density of this rain of secondary electrons must decrease as one moves away from the beam spot. However, if the beam is kept on long enough the cumulative effect of this rain of secondary electrons is sufficient to at least partially discharge the positive potential areas in a neighborhood, spanning perhaps over several storage spots.

If these partly discharged potential peaks are those of stored "dots" or "zeros", a distorted signal is obtained. This is because the "dot" signal, normally due only to the electron cloud, now has superimposed upon it an additional signal due to recharging of the phosphor screen back to its equilibrium potential. The more severe the discharge of the "dot" equilibrium potential peak due to stray secondary electrons, the more severe a distortion is encountered until at last a practically fullfledged "dash" signal is obtained as shown in Figure 4(C).

The Improved Storage System

It was shown above that the dot signal is quite vulnerable to distortion and that in severe cases this distortion is such as to make the dot signal indistinguishable from a normal dash signal at the time of an inspection pulse. In less severe cases discrimination can only be made by careful amplitude comparison of the two signals, the normal dash signal then being of larger positive amplitude than the distorted dot.

As both the dash and the dot signals can be positive at the time of an inspection pulse, it seems that the initial portion of the signal waveform is perhaps not the best characteristic to rely on for discrimination between the two signals. Better results might be obtained if one could afford to wait and inspect the signals at some later instant. This delay requires that the electron beam is kept on for a longer time interval before a decision is reached as to whether one has a dot or a dash type of signal. When the beam turn-on pulse is lengthened the dot signal changes its character to that shown in Figure 5(B). It still is caused solely by the transient presence of an electron cloud in the vicinity of the pick-up plate and as such can properly be interpreted as the differentiated waveform of the beam turn-on pulse itself. The shape of the dash signal on the other hand is only slightly affected and is as shown in Figure 5(A).

In the conventional storage systems the inspection pulse comes at time t_1 . In the system proposed here, however, the inspection pulse is moved to the later time of t_2 . Discrimination between the dot and the dash signal is on the basis of whether the signal at time t_2 is zero or positive (dot signal), or exceeds a certain minimum negative amplitude (dash signal).

For ideal waveforms the maximum amplitude difference between the dot and the dash signals is somewhat greater at time t_1 than at t_2 so that the proposed change may not seem to be much of an improvement. For signals distorted by spillover however, the reverse certainly is true. Figures 6 and 7 show how the dot signal of the modified system is affected by spillover. The two oscillograph traces shown in each picture are those of the distorted signal together with an undistorted signal shown for comparison.

As would be expected the negative peak at t_1 disappears and in the worst cases changes to a positive peak which rivals in amplitude the initial positive peak of a normal dash signal. The amplitude difference between the distorted dot and the normal dash signals has at the time t_1 shrunk almost to the vanishing point. On the other hand consider the amplitude difference at time t_2 . The dot signal is still positive at this time; the dash signal is negative and as will be shown later has changed very little. The amplitude difference between the two signals at t_2 instead of getting smaller has actually increased. No difficulty is therefore encountered in discriminating between the two signals even under severe conditions of spillover.

Figure 8 shows a dash signal affected by spillover. The features which make it differ from a normal dash are a somewhat larger positive peak and a slightly decreased negative peak. The decrease of the amplitude of the negative peak is of some concern as it could eventually if severe enough cause a "one" signal to be interpreted as a "zero" and thus cause spillover. This amplitude decrease however has been found to be very small and only by purposely defocusing the beam while continuously consulting a single spot could it be made severe enough to cause misinterpretation.

In the conventional dot-dash system the various design parameters have been carefully chosen to enhance the generation of a large initial positive peak for the dash signal. In the modified system, however, this peak is not made use of. Some of the design parameters besides the length of the beam turn-on pulse have therefore been changed to favor the generation of a large negative dash amplitude at the time of the inspection pulse (time t_2 , Figure 5). In particular the saw-

tooth or the twitch signal, which is applied to the deflection plates to produce the dash display has been shortened from four to approximately one and one-half microseconds. In the conventional dot-dash system, the purpose of the sawtooth deflection voltage is to cause the beam to move slowly away from the dot position (position X, Figure 2), and by these means cause the potential peak at that point to be discharged. This process normally takes about four microseconds. When only one microsecond is allowed, those surfaces that come under the beam are charged to a positive equilibrium potential as before. However, now there is time only for but a slight discharge at the trailing edge of the beam. Hence the two potential storage patterns will probably be somewhat of the nature shown in Figure 9. Now when the beam is again turned on at position X there will be a small initial positive signal peak due to charging of the phosphor surface back up to equilibrium potential followed by an enhanced negative peak caused by the slower discharge of the large shaded positive area of Figure 9.

Test Results

Several single cathode ray tube units have been tested in the system just described. The amplifiers and gating circuitry used were those presently in use on the SWAC with the one modification that the signal output from the amplifier was inverted. This was done to facilitate gating of the dash signal which then could be done in the same manner as on the standard SWAC system.

Among the cathode ray tubes tested were some which had been withdrawn from the SWAC memory system because of excessive spillover and some which were currently in use.

Direct comparison of results of spillover tests indicate that improvements in read-around ratios for poor tubes may range from three to four. On good tubes the tests were less conclusive as the maximum read-around ratio obtainable on the test set was 256.

However, under these conditions the modified system always performed at least as well or better and in no case was a lower read-around ratio obtained on this system than on the standard dot-dash system.

Flaws

The second major limitation of a cathode ray tube memory is that of flaws as mentioned earlier. - Apparently there exist on the phosphor surface minute specks of foreign or damaged material whose secondary emission characteristics are such as to severely attenuate the initial positive portion of the conventional dash signal. A typical flaw signal is shown in Figure 10. The raster has been purposely positioned so as to give maximum attenuation of the initial positive peak and as may be seen from the photograph it is almost completely missing. A "one" could therefore not be stored at this spot in the conventional dot-dash system. Figure 11 shows the signal obtained from the same flaw area when the raster was so positioned as to give a minimum amplitude for the negative peak of the dash signal. The amplitude of the negative peak has decreased only about 10% and the modified system stored perfectly both "zeros" and "ones" at this point.

Indeed it was found after testing several flaw areas on several cathode ray tubes that as a rule the negative going peak of the dash signal was very much less affected by flaws than the initial positive peak of the dash.

It should be pointed out though that there still exist flaws which would not store information in either system.

Conclusions

A modification of the standard dot-dash cathode ray tube storage system has been described. It appears from tests on single cathode ray tube units that this system is superior to the conventional system with respect to spillover and resistance to flaws.

Acknowledgment

Much of the work described here has been carried out collectively by the engineering staff of the Institute for Numerical Analysis. In particular, Mr. L. E. Justice and Mr. E. D. Martinolich have contributed to this project.

References

1. F. C. Williams and T. Kilburn, "A Storage System for Use with Binary-Digital Computing Machines," Journal IEE, Part IIIA, Vol. 96, p. 81, March 1949.
2. C. V. Parker, "Charge Storage in Cathode Ray Tubes," Proceedings of the IRE, Vol. 39, Number 8, p. 900, August 1951.
3. T. Kilburn, unpublished work on cathode ray tube storage phenomena, received at the Institute for Numerical Analysis in December 1951.
4. National Bureau of Standards Electronic Computers Laboratory, "First Quarterly Progress Report of the Research Program for Improving Cathode Ray Storage for Computers," NBS report, November 1952.

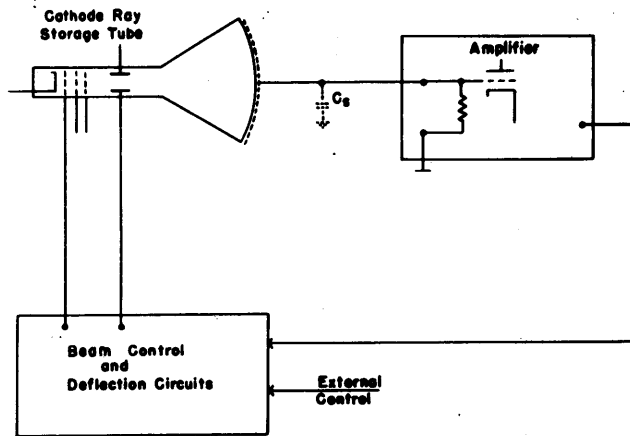

Figure 1.

Basic Elements of a Cathode Ray Tube Storage System

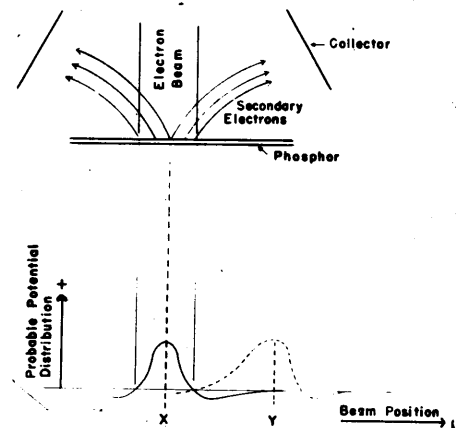

Figure 2

Probable Potential Distribution Across a Storage Cell.



Figure 3. Typical "One" and "Zero" Signals for a Conventional Dot-Dash Storage System

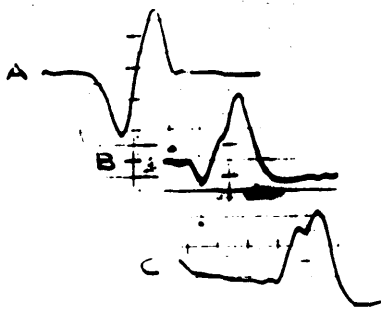

Fig. 4
Progressive Distortion of the Dot Signal
as Caused by Spot Interaction.

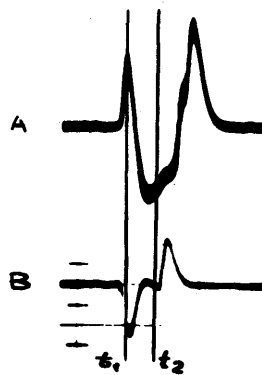

Fig. 5
Typical "One" and "Zero" Signals for the
Modified Dot-Dash Storage System.

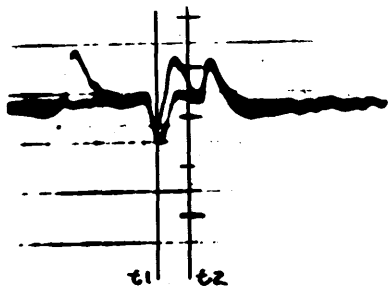

Fig. 6
Distortion of the Dot Signal, by Spot
Interaction for the Modified Dot-Dash
Storage System.

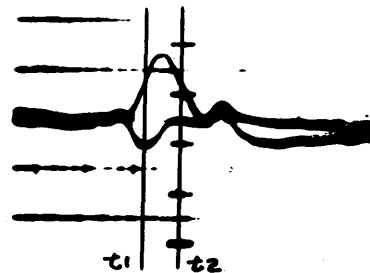

Fig. 7
Severe Distortion of the Dot Signal in
the Modified Dot-Dash Storage System.

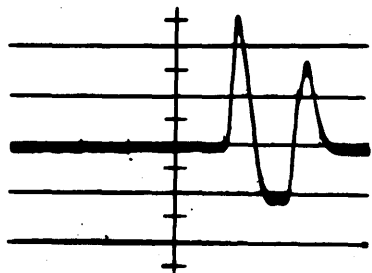

Fig. 8
Distortion of the Dash Signal
by Spot Interaction.

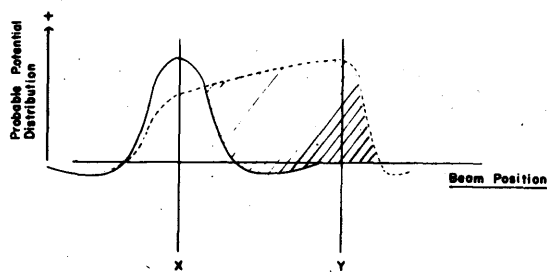

Fig. 9
Probable Potential Distribution Across a
Storage Cell for the Modified Dot-Dash System.

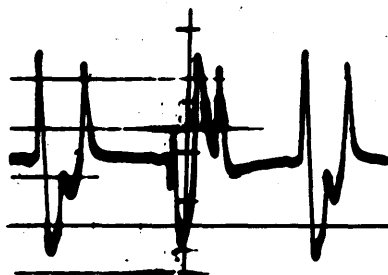

Fig. 10
Dash Signal from a Flaw Area. Storage Raster
Positioned to Give Minimum Positive Dash.

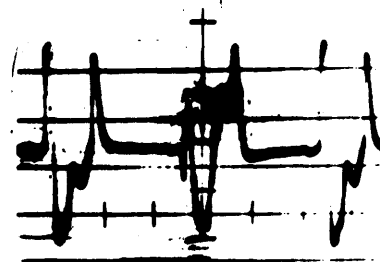

Fig. 11
Dash Signal from a Flaw Area. Storage Raster
Positioned to give Minimum Negative Dash.

NONLINEAR RESISTORS IN LOGICAL SWITCHING CIRCUITS

F. A. Schwertz and R. T. Steinback
Mellon Institute*
Pittsburgh 13, Pa.

Introduction

Nonlinear resistors may be used to replace whole arrays of crystal rectifiers in certain logical switching circuits. Where such replacement is possible, considerable savings in fabrication and component costs may be effected, because both the nonlinear resistors and the associated connecting busses are fabricated by applying printed circuit techniques to standard plastic- or ceramic-bonded sheets of semiconductors such as granular silicon carbide. The manner in which groups of nonlinear resistors may be used in logical switching circuits is described here in terms of simple circuits which employ both "matrix logic" and "grid logic." The technique is experimentally illustrated with the aid of a pair of simple matrix-type function switches, encoded as binary-to-octal converters. The first employs individual nonlinear resistors as the switching elements; the second is fabricated from a rubber-bonded sheet of granular silicon carbide. Two similarly-constructed decoding matrices are used to transform the converters into three-binary-digit adders. The output voltage-patterns for these devices are compared photographically.

Nonlinear Resistors in "and" and "or" Circuits

Since logical switching circuits comprise primarily combinations of "and" and "or" circuits, the behavior of nonlinear resistors in such circuits will first be described. Typical of such circuits is the "logical or" circuit shown in Figure 1. The elements labeled a, b, and c are ordinarily crystal diode rectifiers. Depending on the positions of the switches shown at the left of the figure the diodes may be either connected to ground potential or to the potential E. If either a or b or c (or more than one) is connected to E, the output voltage terminal is raised to the potential E provided the voltage drop in the crystal rectifiers is negligibly small. Hence the designation "logical or" is employed to describe the circuit action.

*The research reported in this document has been made possible through support and sponsorship extended by the Radiophysics Directorate of the AF Cambridge Research Center, RDC, under Contract AF 19/122/-376. It is published for technical information and does not represent the recommendations or conclusions of the sponsoring agency.

The question is now raised, What will be the voltage pattern on the output terminals if the diode rectifiers are replaced by passive elements very unlike diode rectifiers, namely linear resistors? This question can be answered in a direct way where it is assumed that all the linear resistors have the same resistance, r . In this case the allowed values of the output voltage e are given by the equation

$$F_N = \frac{(N/M)}{1 + (1/xM)}, \quad N = 0, 1, 2, \dots M \quad (1)$$

where $F_N = e/E$, x is the ratio of the load resistance, R , to the switching resistance, r , and N is the total number of resistors r connected to the potential E . M designates the total number of switching resistors in the "or" circuit. In the special case where $M = 3$, as in Figure 1, and the load and switching resistors are equal, four equally-spaced voltage levels are obtained corresponding to $F_0 = 0$, $F_1 = 1/4$, $F_2 = 1/2$, and $F_3 = 3/4$. Actually there are eight possible configurations which the input switches on Figure 1 may assume; some of these configurations, however, yield the same voltage levels as others, and F_N consequently assumes only four independent values. The voltage levels may be "read," for example, on an oscillograph, as all the possible switching configurations are "written" into the "or" circuit. The "writing" may be done very conveniently with the aid of three series-connected binary scalars, the pair of output voltages from each stage of the scaler serving as input voltages to cathode-followers; these in turn serve as low-impedance sources for the circuit input voltages. The photograph in Figure 2 depicts a voltage pattern obtained in this way. For this picture a circuit containing identical load and switching resistors at 56,000 ohms was employed. The three-stage binary scaler was triggered once every 10 microseconds. The scaler output voltages fluctuated approximately between 100 and 200 volts, and the load resistor in the "or" circuit was biased 100 volts above ground. In this situation four equally-spaced levels corresponding to $F = 0, 1/4, 1/2$ and $3/4$ were obtained as predicted above. These levels are shown in Figure 2. They are also shown diagrammatically in Figure 3. The level difference ($F_3 - F_0$) in this figure represents the desired signal. The levels corresponding to F_1 and F_2 are in the nature of "noise," since, for proper action as an "or" circuit, it is desirable that F_1, F_2 and F_3 be coincident. It is therefore useful to arbitrarily define a "signal-to-noise" ratio S , by the expression

$$S = \frac{F_3 - F_0}{F_2 - F_0} = 3/2. \quad (2)$$

In the more general situation where there are M switching resistors, the corresponding ratio is

$$S = \frac{M}{M-1}$$

This ratio approaches unity quite rapidly as M increases, so that above $M = 3$, circuits employing linear switching resistors are probably unsatisfactory. The situation is quite different, however, where nonlinear resistors are employed as switching elements. These resistors display a voltage-current characteristic curve defined by the equation

$$i = k V^n \quad (3)$$

where i is the current carried by the resistor and V is the applied voltage. k and n are constants, and n generally lies between the limits 4 and 7. If the nonlinear load resistors and switching resistors have the same value of n but different coefficients, say K and k respectively, the voltage levels analogous to those defined by equation (1) are given by

$$F_N = \frac{1}{1 + A_N} \quad (4)$$

$$\text{where } A_N = \left[\frac{1 + (M-N)x}{Nx} \right]^{1/n}, \quad N = 0, 1, 2, \dots, M \quad (5)$$

and $x = k/K$

The voltage levels obtained from equation (4) for $n = 5$ are shown on Figure 4 for a three input "or" circuit ($M = 3$) and for $x = 1$. The corresponding experimental results are shown on the photograph in Figure 5. The results depicted on this figure were obtained at a trigger-pulse rate of 10,000 per second. The nonlinear resistors (Thyrites GE type 8386118G1) were not identical in characteristics; their spread in resistance is indicated by the fact that 45 ± 3 volts were required to produce a current of one milliampere. This situation produced a slight splitting of the voltage levels. The "signal-to-noise" ratio was little affected, however; the calculated value of 4.8 agreed very well with the experimentally determined value of 4.7.

The data indicate that the nonlinearity serves to squeeze the unwanted voltage levels together and to increase the "signal-to-noise" ratio. By analogy with equation (2), this latter quantity may be calculated from the expression

$$S = \frac{1}{1 - B_n}, \quad (6)$$

$$\text{where } B_n = \frac{1 + (1/Mx)^{1/n}}{1 + \left[(1/x) + (M-1) \right]^{1/n}}$$

This equation-pair indicates that as n gets larger B_n approaches unity, and hence the "signal-to-noise" ratio increases rapidly as n increases. Conversely, as n decreases toward unity, the "signal-to-noise" ratio decreases to the value predicted by equation (2). These facts are expressed graphically in Figure 6 where the "signal-to-noise" ratio, S , is plotted against the exponent n for various values of M . The information on this figure refers to the special case

where $x = 1$; for lower values of x of the signal-to-noise ratio is increased. This increase, however, is obtained at the expense of a decrease in the amplitude of the desired signal, and a compromise is required. For example, it may be specified that the product of the signal-to-noise ratio, S , and the desired signal, F_M , be a maximum and consequently that the quantity $F_M^2/(F_M - F_1)$ be a maximum. This requirement leads to the equation

$$(A_1 - 2A_M - 1) + \frac{A_1 (1 + A_M)^2}{A_M(1 + A_1) (1 - x + Mx)} = 0 \quad (7)$$

where the A 's have the form given by equation (5). For the case where the number of binary inputs is $M = 3$ and the degree of nonlinearity is $n = 5$, equation (7) leads to a value of $x = 0.18$. This yields for $F_M = F_3$ a value 0.47 and for the signal-to-noise ratio a value of approximately 8.³ The situation can therefore be represented by a voltage-level diagram very similar to Figure 5. This diagram, it will be recalled, was constructed for the case where $M = 3$ and $x = 1$; the signal-to-noise ratio was 4.8.

As mentioned earlier, where ideal diode rectifiers (possessing zero forward resistance and infinite back resistance) are employed as switching elements, the output voltage of the "or" circuit assumes only two values, 0 and E . Similarly, where ideal nonlinear resistors (degree of nonlinearity $n = \infty$) are used, equation (4) predicts that the output voltage assumes only the values 0 and $E/2$ quite independently of the values of x , M , and N . In other words, where ideal nonlinear resistors are employed as switching elements, ideal "or" circuit action will be obtained although the amplitude of the input voltage will be cut in half. The signal-to-noise ratio will, however, be infinite.

The circuit depicted in Figure 1 was described as an "or circuit" but it might equally well be described as an "and circuit" if it is assumed that the desired output voltage is zero and not E . This will occur only when a and b and c are all connected to ground. Alternately, the circuit shown in Figure 1 can be converted to an "and circuit" by raising the common lead to the load resistors to the potential E . The output voltage will then be high ($=E$) only when a and b and c are high ($=E$).

Nonlinear Resistors in "Matrix Circuits"

The manner in which simple "and" and "or" circuits may be combined to effect logical switching operations is illustrated by the function switch,¹ represented in Figure 7. It consists essentially of eight "or" circuits arranged in a parallel array. It may be regarded as a binary-to-octal converter, since it may be employed to convert any three digit binary number into the octal equivalent digit. The binary digits are represented on the binary input lines shown at the left side of the figure, and the octal equivalent digit appears on one, and only one of the eight output terminals corresponding to the octal digits 0 to 7 inclusive.

¹The Subcommittee of Electronic Computer Terms (Proc. I. R. E., 39, 274, 1951) defines a function switch as "a network or system having a number of inputs and outputs and so connected that signals representing information expressed in a certain code, when applied to the inputs, cause output signals to appear which are a representation of the input information in a different code."

Physically the converter comprises two sets of parallel coplanar, conducting busses arranged one above the other in such a way that in plan view, the busses appear to intersect each other at right angles. At certain of the virtual points of intersection, switching elements are inserted, in a pattern which yields the required output. Ordinarily diode rectifiers, as mentioned before, are used as switching elements in this type of device. These are represented by the circles in Figure 7, and they are assumed to be connected in such a way that conduction will be effected when a positive voltage is placed on the horizontal bus lines and the vertical lines are grounded. If then a positive voltage, E volts above ground, is placed on a given horizontal conductor, all the diodes connected to it will conduct current to ground through the load resistors, R . The ends of the load resistors connected to the octal output positions will then be raised above ground potential by an amount equal to the iR drop in the load resistor. If now the adjacent horizontal lines are grouped together in pairs, and a voltage pattern is placed on the pairs such that when one member of the pair is at a voltage level E the other member of the pair is grounded, one, and only one of the eight output terminals will remain at ground potential for each configuration of the input voltage pattern. There are, accordingly, eight input voltage configurations corresponding to the eight output terminals. For the voltage configuration shown in Figure 7, only the output terminal designated by the digit 7 is at ground potential; all the other output terminals are, ideally, at a common voltage level E , above ground. Now the digit 7 can be correlated with the equivalent binary number in the following way. Let the upper bus line in each input pair be at the potential E and lower line be at the potential 0 in order to represent the binary digit "one." Let the reverse be true for a binary zero. Furthermore, let the uppermost pair of horizontal lines represent the highest order digit position. The configuration shown in Figure 1 then symbolizes the binary number $111 = 1 \times 2^2 + 1 \times 2^1 + 1 \times 2^0 = 7$. In a similar manner all of the three binary digit numbers (eight in all) may be represented by their equivalent octal digits. For test purposes, all of the required digit combinations may be obtained, as explained above, in cyclic sequence, with the aid of a three stage binary counter. Such a test pattern was employed to examine the binary-to-octal converters described in the next section.

Binary-to-Octal Converters

The current which flows through a nonlinear resistor is inversely proportional to the n 'th power of its length, other things being equal. It is this fact which makes possible the fabrication of complete function switches with the aid of resin- or ceramic-bonded sheets of silicon carbide. For example, if the degree of nonlinearity is $n = 5$, an increase of a factor of four in the resistor length produces a 1024-fold decrease in the current. Thus two nonlinear resistors formed side-by-side on a flat sheet of rubber-bonded silicon carbide are essentially non-interacting provided their distance of separation is equal to, say, four or five times the thickness of the sheet. Furthermore

these resistors may be materialized simply by spraying metal electrodes on the function switch blanks through appropriately formed stencils. Whole function switches, comprising many nonlinear resistors and the associated inter-connecting busses may be fabricated in the same way.

The binary-to-octal converter referred to above was formed from a sheet of rubber-bonded silicon carbide about 1/16th of an inch thick. This sheet was kindly supplied by The Carborundum Co. (Sample No. 3777-1-1C) and was made with the aid of the same techniques employed in the manufacture of standard silicon carbide "cut-off" wheels. It contained about 89% of Electrical Grade Grit No. 36 and about 11% of rubber binder by weight. The average particle diameter for this grit number is very roughly 0.02 inches.

A photograph of the converter is shown in Figure 8. The front face of the converter is shown on the left hand side of the picture and the back face on the right hand side. The electrodes and the associated bus lines shown in the photograph were put down in a single operation. The diameter of the switching resistor electrodes was 0.375 inches and the diameter of the load resistors was 0.25 inches. Since the connecting busses were only about 1/16 inches wide, it was thought at first that there would be no "cross-talk" between the lines on the front and back faces at the points of virtual intersection. However, it was found necessary to insulate the lines from the silicon carbide on one of the faces at the intersection points. This involved spraying a clear insulating lacquer through a stencil prior to applying the silver conducting paint.

About 48 ± 2 volts were required to pass one milliampere of current through the switching resistors and about 58 ± 2 volts for the load resistors. The index of nonlinearity n was 4.5.

As mentioned earlier, a logically identical converter was fabricated with the aid of individual, selected, nonlinear resistors (Thyrites GE type 838611G1). In this case about 39 ± 2 volts were required to pass a milliampere of current through both the switching and load resistors. The index of nonlinearity n was 5.0.

The voltage output patterns produced at the octal output terminals of these converters are compared on Figure 9 where a three-stage binary counter operating at a ten thousand per second counting rate was used as the source of input digits. For this type of input the selected line should be "high" relative to the neighboring lines for only one out of eight pulse times. Figure 9A shows the shape of the binary digit input pulses, Figure 9B the output voltage at one of the converter output terminals, and Figure 9C the output at a terminal of the Thyrite converter. Figures 10 and 11 present similar data for counting rates of 50,000 and 100,000 per second. The signal-to-noise ratio for the output pulses appearing on these figures is roughly 2 1/2 to 1. The quality of the output obtained from the two converters is about the same. The results at the higher frequencies are vitiated by the poor output wave form obtained from the binary counter.

Three-Binary-Digit Adders

The output pulses from the binary-to-octal converters were decoded in such a way as to transform them into three-binary-digit adders. The manner in which this was done is illustrated in Figure 12 which shows the decoding matrix attached to the binary-to-octal converter. The decoding matrix was fabricated from the same sheet of rubber-bonded silicon carbide as the converter. The physical separation was effected for purposes of illustration, but the encoding and decoding matrices could equally well have been fabricated on the same continuous sheet.

For test purposes, the three-stage binary counter was again used as a source of digit pulses. In this way, all of the possible combinations of three binary digits were supplied to the adder, in a cyclic manner. The output "sum" and "carry" pulses for the silicon carbide sheet adder and a logically identical adder employing individual, selected, nonlinear resistors (Thyrites GE type 838611G1) are displayed in Figures 13, 14, and 15 for counting rates of 10,000, 50,000, and 100,000 per second respectively. In all cases, the "sum" and "carry" digits are clearly delineated, and, as in the case of the converters, the quality of output obtained from the two adders is about the same. Inequalities in output pulse heights are probably associated with the fact that the switching resistors are not identical in characteristics.

Nonlinear Resistors in "Grid Circuits"

Where it is desirable to have an amplified output pulse, the output signal of a "logical and" or "logical or" circuit may be fed to the grid of a triode amplifier. A two-input, linear resistor "logical and" circuit employed in this fashion is shown in Figure 16.² The indicated arrangement may be used only if standardized input pulses of amplitude E are employed. In this situation the output voltage delivered to the grid assumes the three values, 0, E/2, and E. If therefore the triode will deliver an output pulse only where the grid assumes the voltage E, that is, only where a twin-coincidence of input pulses occurs. In general, if not two, but N coincident pulses are to be detected, the grid must be biased between (M-1)E/M and E. This precludes the use of such a gate for M much larger than five, for in this case the grid must discriminate between signals of amplitude 0.8E and E. This requirement places severe limits on the tolerance allowed in the amplitude of the input signals. However if nonlinear resistors are substituted for the linear resistors, the grid may assume the voltages defined by the equation

$$e = \frac{E}{[1 + (M-N)/N]^{1/n}}, \quad N = 0, 1, 2, 3, \dots M. \quad (8)$$

²High Speed Computing Devices, Engineering Research Associates, p. 40, McGraw-Hill Book Company, 1950.

The voltage level lying closest to E is that for which $N = M-1$, that is, for

$$e = \frac{E}{\left[1 + \frac{1}{M-1}\right]^{1/n}} \quad (9)$$

For $e = 0.8E$ and $n = 5$ the allowable value of M (the number of input voltages) is approximately 1000 provided that the amplitudes of the input signals are all rigorously equal. Where this is not the case, fewer inputs may be used, but there will still be considerable advantage in employing non-linear resistors in this type of resistance grid gate.

Practical Considerations

A practical difficulty was encountered in adapting rubber-bonded sheets of silicon carbide to switching applications. This may best be described with reference to the manner in which these sheets were tested. For testing purposes, a $3/8$ " diameter electrode was placed on each surface of the sheet, at diametrically opposite points, by spraying silver conducting paint through a suitable stencil. The voltage-current characteristic curve for the nonlinear resistor so-formed was then obtained. If more than 50 volts were required to pass a milliampere of current through the resistor, the sheet was rejected for function switch applications. If less than 50 volts were required to pass a milliampere, the sheet was further tested for uniformity by placing electrode-pairs at widely separated locations on the sheet. In general, it was found that sheets displaying low impedance were non-uniform, but that sheets showing high impedance, say one milliampere at 150 volts, were remarkably uniform in characteristics. These facts can be understood by recognizing that the seat of the resistance in nonlinear resistors is at the grain-grain contacts. Thus, where a large number of grains are required to bridge the distance between the two faces of the rubber-bonded sheet (high impedance condition) there is statistically little chance of divergence in resistance characteristics from point-to-point over the sheet surface. However, where the number of particles required to bridge the gap is small, the opposite is true. This difficulty can be obviated by employing a more suitable bonding agent than rubber, for example, a resin or a ceramic bond permitting a greater ratio of silicon carbide to bond material.

Conclusions

The information presented here indicates that nonlinear resistors fabricated from granular aggregates of silicon carbide may be used effectively in certain logical switching circuits. The fact that such resistors and the associated connecting busses may be materialized from resin- or ceramic-bonded sheets of silicon carbide with the aid of simple metal-spraying techniques yields obvious savings in fabrications and component costs. It should be emphasized, however, that the use of silicon carbide in this connection is not unique, and that its use was dictated primarily by its availability. In general, granular aggregates of semiconductors display voltage-current characteristics qualitatively similar to those of silicon carbide. Some of these display lower grain-grain contact resistance than silicon carbide and may be more adaptable to the fabrication of function switch blanks.

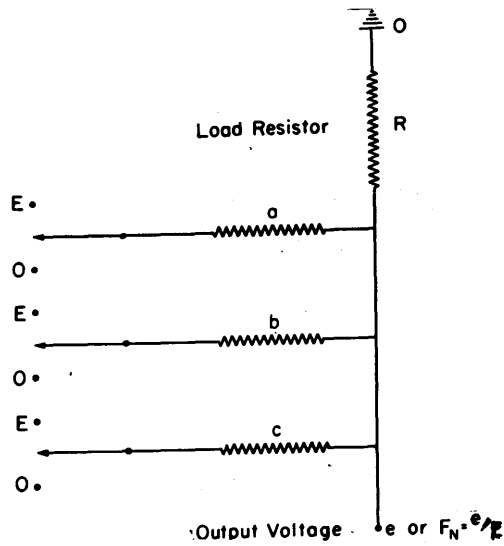

Fig. 1 "Logical or" Circuit.

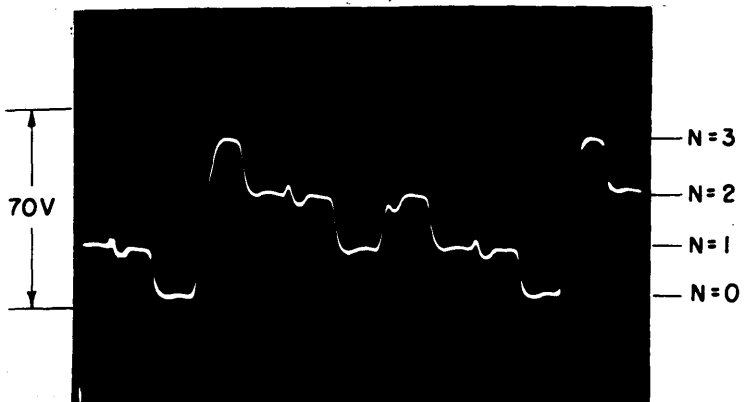

Fig. 2
Experimental Voltage Levels - F_n for Linear Switching Elements.

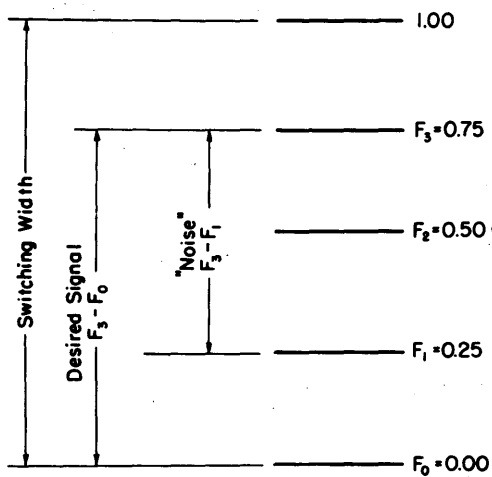

Fig. 3
Calculated Voltage Levels - F_n for Linear Switching Elements.

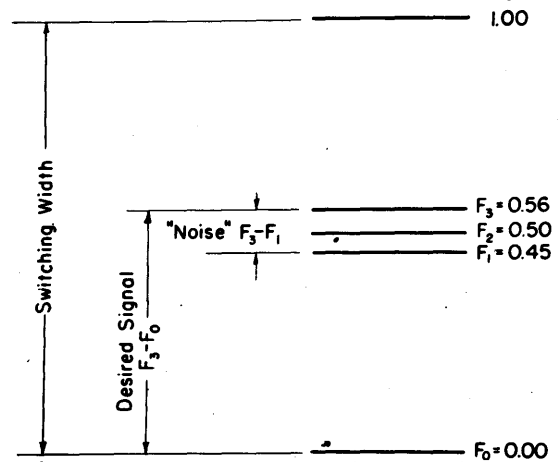

Fig. 4
Calculated Voltage Levels - F_n for Nonlinear Switching Elements.

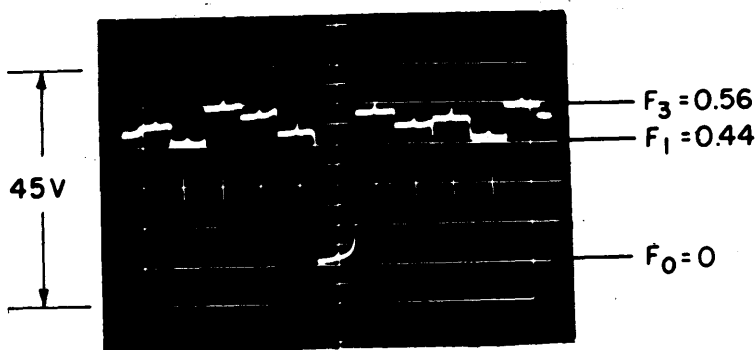

Fig. 5
Experimental Voltage Levels - F_n for Nonlinear Switching Elements.

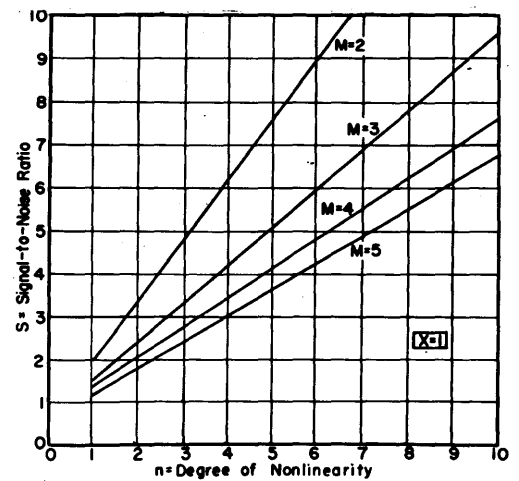

Fig. 6
Effect of Nonlinearity on Signal-to-Noise ratio.

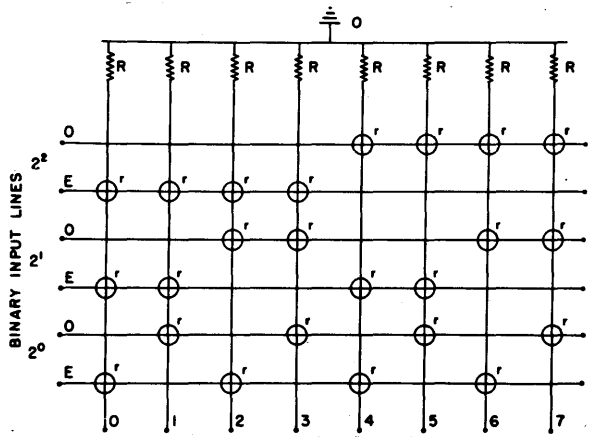

Fig. 7 A Simple Function Switch

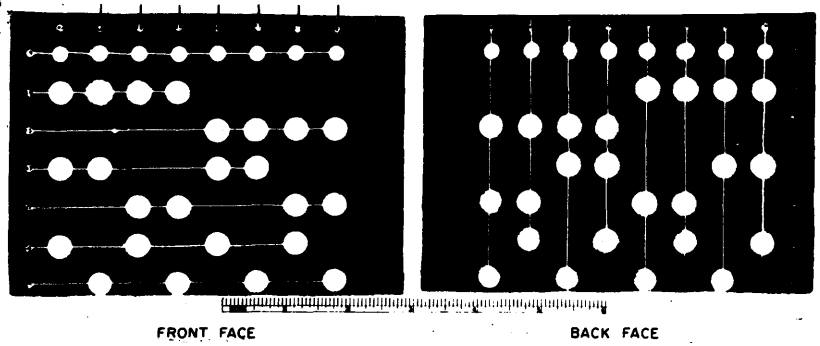
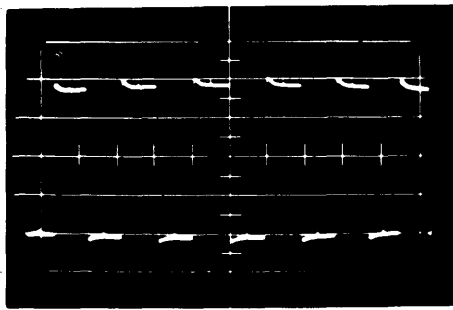
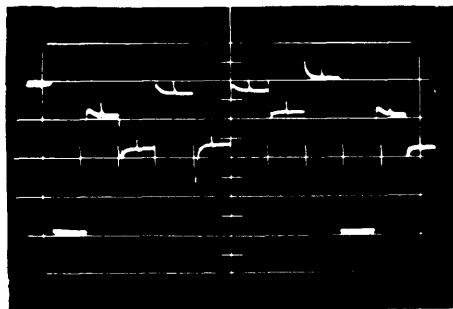

Fig. 8 Binary-to-octal converter



135V

Input Pulse Waveforms



45V

Rubber-bonded Silicon Carbide Converter

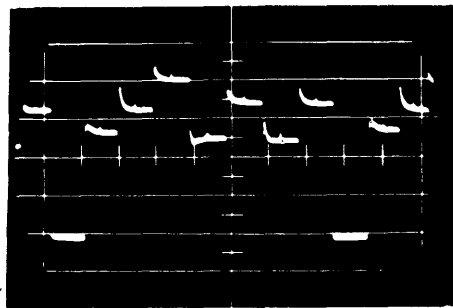

40V

Thyrite Resistor Converter

Fig. 9 Converter Output Voltage Patterns (10,000 counts/sec.)

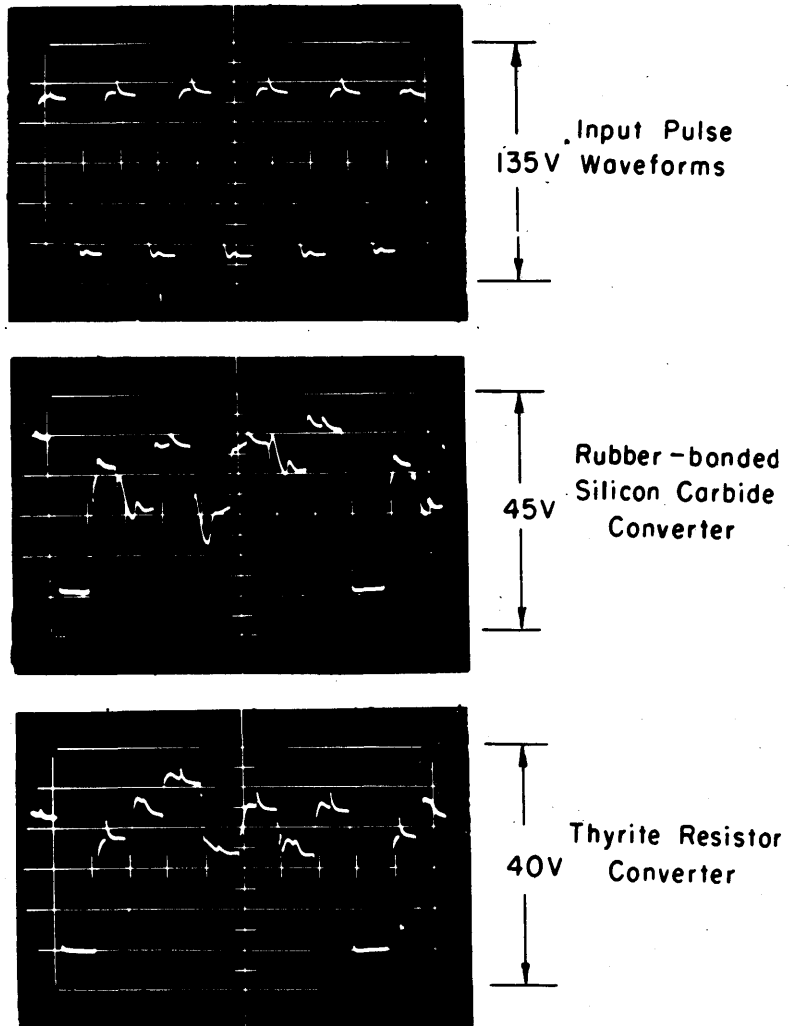

Fig. 10 Converter Output Voltage Patterns
(50,000 counts/sec.)

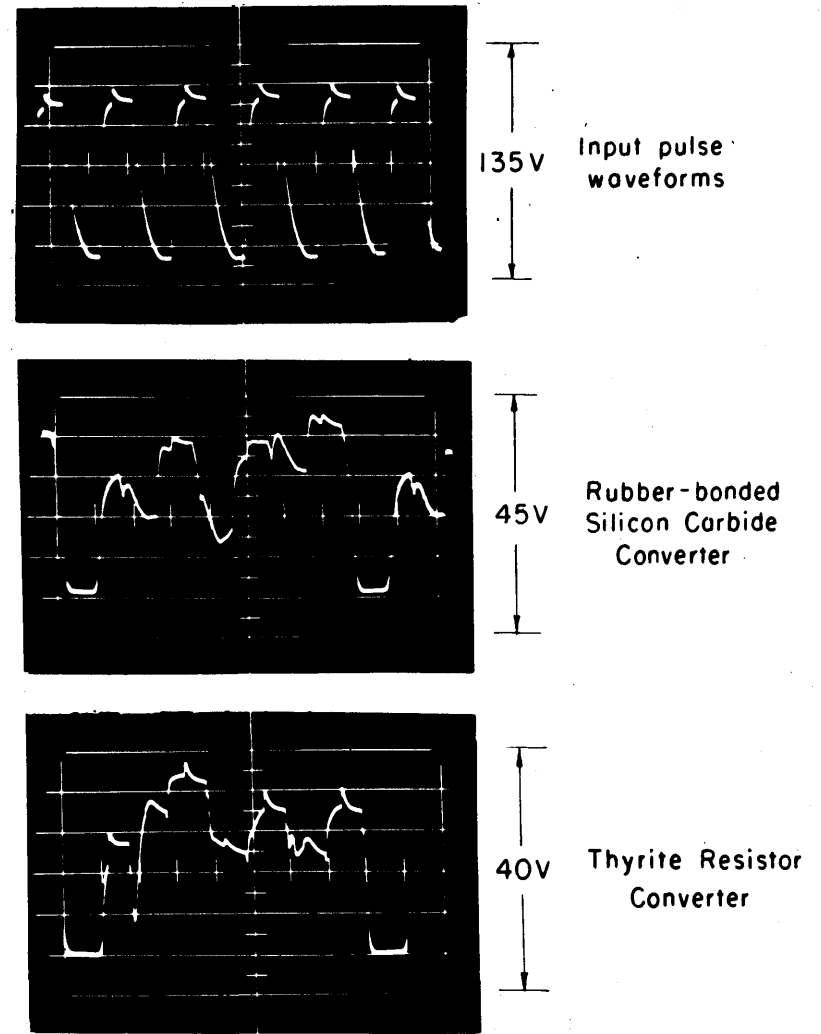

Fig. 11 Converter Output Voltage Patterns
(100,000 counts/sec.)

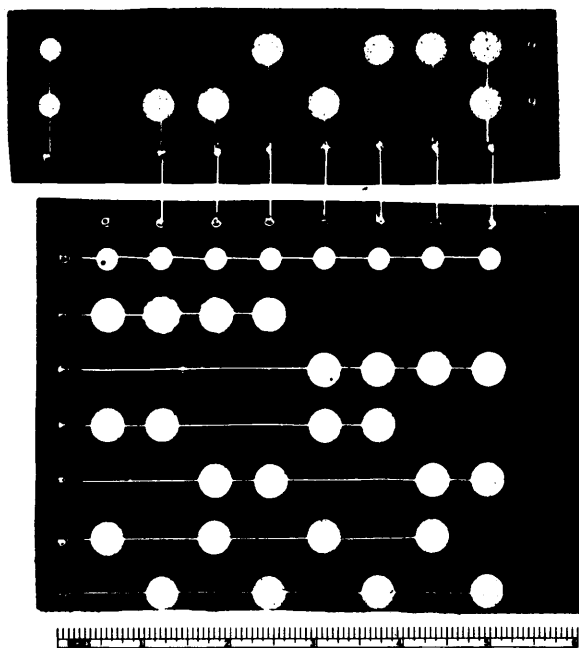

Fig. 12 Three-Binary-Digit Adder

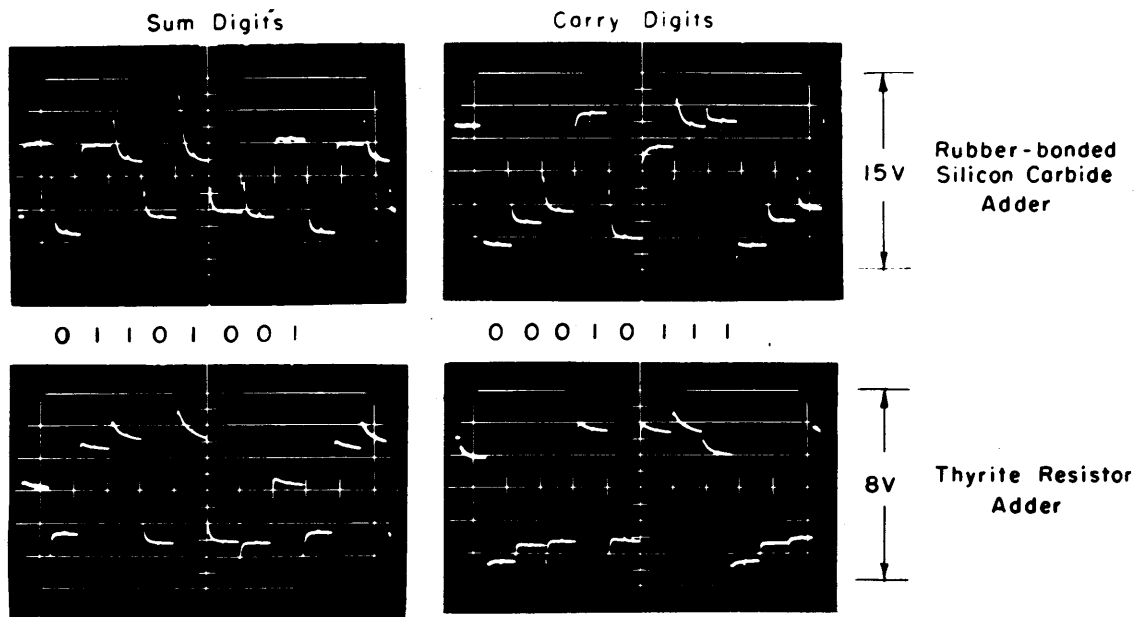
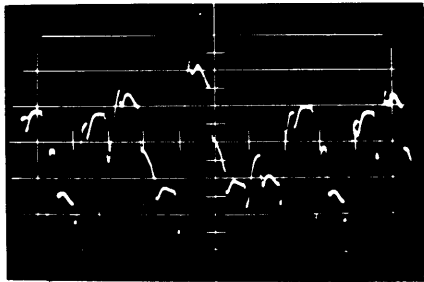

Fig. 13 Adder Output Voltage Patterns (10,000 counts/sec.)

Sum Digits



0 1 1 0 1 0 0 1

Carry Digits

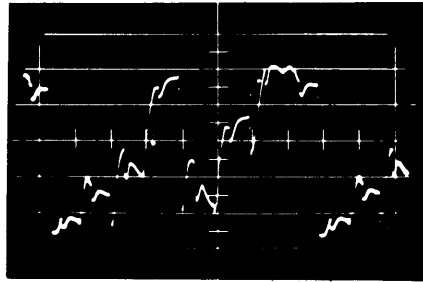

0 0 0 1 0 1 1 1

15V
Rubber-bonded
Silicon Carbide
Adder

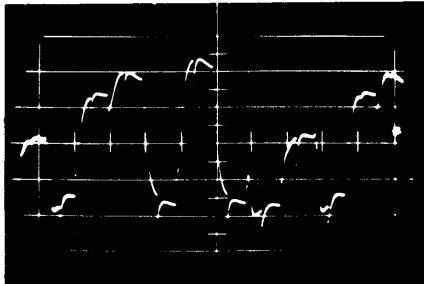

Sum Digits

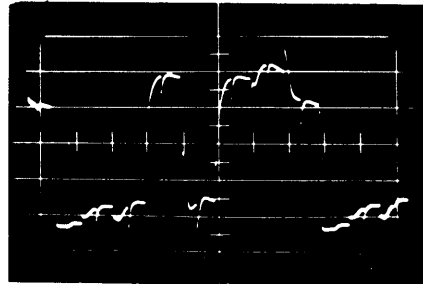

Carry Digits

8V
Thyrite Resistor
Adder

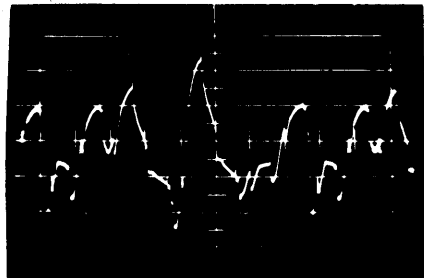

0 1 1 0 1 0 0 1

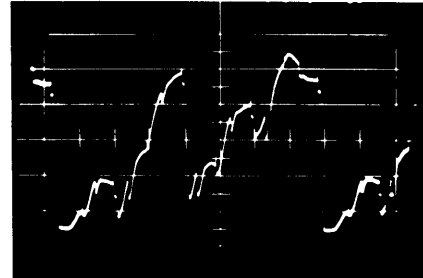

0 0 0 1 0 1 1 1

15V
Rubber-bonded
Silicon Carbide
Adder

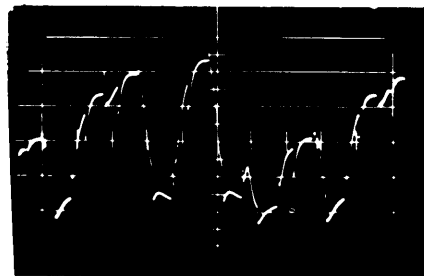

Sum Digits

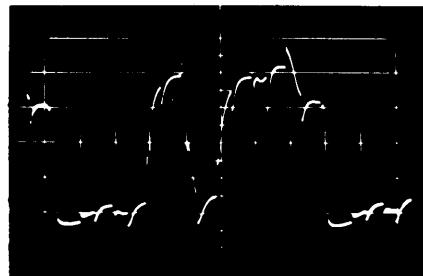

Carry Digits

8V
Thyrite Resistor
Adder

186

Fig. 14 Adder Output Voltage Patterns (50,000 counts/sec.)

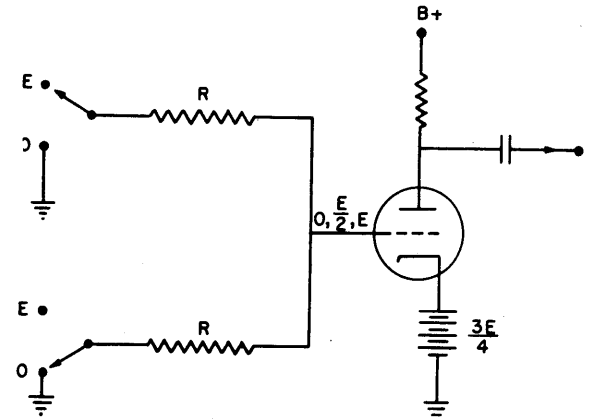

Fig. 15 Adder Output Voltage Patterns (100,000 counts/sec.)

Fig. 16 Resistor Grid Gate.

NEW LABORATORY FOR
THREE-DIMENSIONAL GUIDED MISSILE
SIMULATION

Louis Bauer
Project Director
Project Cyclone
Reeves Instrument Corporation
New York, New York

Introduction

Project Cyclone at the Reeves Instrument Corporation is under the cognizance of the Bureau of Aeronautics of the Navy. The function of Project Cyclone is primarily the development and operation of a Guided Missile Simulator, and the establishment and operation of a Simulation Laboratory. Problems in other fields are also studied and analyzed using the computing machinery of the Simulation Laboratory.

The original Guided Missile Simulator consisted of two types of flexible computers, and one large computer with DC and AC components which were permanently connected to handle those equations which were common to all Guided Missile problems. This large computer was known as the Ballistic Computer. The flexible computers were a DC analog computer with servo-mechanisms units (now known as the Reeves Electronic Analog Computer, or REAC®) and an AC analyzer. The flexible units were intended for simulation of those aspects of Guided Missile problems which could be expected to vary widely from one problem to the next.

Because of the immediate success of the flexible DC analyzer and because of the pressure of problems awaiting solution on it, the AC analyzer was somewhat neglected; it never performed as well as the REAC and was later abandoned. Work on the Ballistic Computer was continued until a satisfactory solution to a three-dimensional check problem was obtained. However, by that time REAC techniques had advanced sufficiently so that it was possible to obtain the solution to this check problem on REACs. After careful consideration of the relative difficulties of setting up such problems on the Ballistic Computer, and of making the problem work (i.e. making the machine perform), it was decided to replace the Ballistic Computer by a large installation of REACs and servo units. Other considerations in this decision were the greater flexibility of the REAC equipment which would make it unnecessary to express all Guided Missile problems in the coordinate systems used in the Ballistic Computer, and the fact that a much greater variety of navigational systems was encountered than had been envisaged in the design of the Ballistic Computer.

The result of this decision is the new laboratory for three-dimensional Guided Missile simulation at Project Cyclone.

Basic Block Diagram of Guided Missile Problems and Coordinate Systems

The equipment in the new laboratory was planned to be more than sufficient to handle anything that could be handled on the old Ballistic Computer. The basic elements of all GM simulation problems can be represented in the block diagram shown in Figure 1.

Starting, say, from the aerodynamics computer, we see that the angles of attack and the control surface deflections are accepted as inputs and the forces and moments are produced as outputs. In the force unit the equations of motion (translation) are integrated once, yielding a complete description of the velocity vector. The velocity vector may be given in terms of magnitude and flight path angles, or in terms of its components. In the moment unit the first integral of the equations of motion in rotation is obtained, yielding the angular velocity vector in terms of its components. In the angle of attack computer the kinematic equations of rotation are integrated, yielding the attitude angles; knowing the velocity vector and the attitude, the angles of attack are computed. From a knowledge of the velocity vector the missile coordinates are obtained by the integration of the kinematic equations of translation. Error distances or angles are determined from the missile position and target position. Those in turn form the inputs to the control system which produces the control surface deflections.

The following coordinate systems have been used in the solution of GM problems. (All are righthanded systems; thus the third axis is always completely defined after two axes have been fixed.) (See Figure 2.)

1. Earth Coordinate Systems (ECS): 1E direction is north, 2E east, 3E down. The missile motion is usually determined in this system; sometimes the force equations are solved in this system.
2. Missile Coordinate System (MCS): 1M along missile axis, 2M along right wing, 3M down, as determined by 1M and 2M. The moment equations are most easily solved in this system (Euler equations). The MCS is also used in homing problems when the relative motion of target and missile is computed.
3. Velocity-Earth Coordinate System (VECS): 1VE along the velocity vector, 2VE perpendicular to 1VE

and in a horizontal plane, 3VE determined by 1VE and 2VE. The force equations are frequently solved in this coordinate system.

4. Velocity-Missile Coordinate System (VMCS): 1VM along the velocity vector, 3VM perpendicular to 1VM and contained in the missile symmetry plane (down); 2VM determined by 1VM and 3VM. The VMCS differs from the VECS by a roll angle, and differs from the MCS by the angles of attack. This coordinate system was believed to be essential for a realistic handling of aerodynamic data obtained from wind tunnels. We have found, however, that many times the aerodynamic data are given to us in the missile coordinate system. In such cases it frequently turns out to be more convenient to disregard the VE and VM systems entirely, solve the force equations in the MCS and resolve the motion directly into the ECS.

Additional coordinate systems are encountered in many problems, e.g. Radar CS, Gyro CS, and in the case of wind, a Relative Wind CS.

Computing Equipment

Because of the necessity of converting from one coordinate system to another a number of resolvers are provided in the new simulation laboratory. The availability of DC resolvers was a strong factor in favor of an all DC computing system, as opposed to the hybrid DC and AC system in the old Ballistic Computer.

The new laboratory contains 13 REACs, 14 servo units and 3 special cabinets with additional amplifiers, limiters, relays, etc.

A REAC contains seven integrating amplifiers, seven summing amplifiers, six inverting amplifiers and 23 scale-factor potentiometers. (Figure 3.) The computing amplifiers are identical in basic design and differ only in their feedback and input networks.

Ordinary linear differential equations with constant coefficients, up to the seventh order can be solved on one REAC. Diode limiters are provided, and permit the handling of some non-linear effects. Variable coefficients and non-linearities other than limiting effects can be handled by using a servo unit.

Seven of the servo units are of standard Reeves design, and seven units have special design to handle any additional resolutions that may be necessary in our problems.

A standard servo unit has four separate servos; two of those have four linear multiplying potentiometers and two functional potentiometers each; the other two servos have three linear multiplying potentiometers and one DC resolver each. (These figures do not include the follow-up potentiometers.)

Six of the seven special servo units have two servo motors, each of which drives two DC resolvers and seven linear multiplying potentiometers. The special servos have to be more powerful than the others, because they are driving a heavier load.

Finally there is one special servo cabinet with only one servo which is driving four DC resolvers and seven linear potentiometers. This servo has continuous rotation. In planning the layout for the computer it was expected that provision for resolution about an unlimited rotation would have to be made. In some three-dimensional GM problems the missile may roll over many times. Resolutions of error angles, of aerodynamic forces, etc. about the roll angle can be accomplished by means of this special servo unit. Since the angle in the case of continuous rotation cannot be conveniently represented by a DC voltage, but its derivative can, this servo has also been designed to accept a rate input, i.e. the servo acts as an integrator. The follow-up in this case is a DC tachometer generator. The servo can be reset by switching the follow-up to a potentiometer. Continuous rotation may also arise when the servo is used in "polar", i.e. when the servo rotation is the arc-tangent of the ratio of two voltages. If the two voltages vary in a certain way continuous rotation of the servo will result. This special servo can also be used in this form. Finally provision has been made for adding a synchro if it should ever become desirable to repeat the position of this servo with some other specially constructed servo. We, at Project Cyclone, have not yet had an opportunity to use this servo unit. It was given on loan to Project Typhoon, and has not yet been returned.

The DC resolvers are accurately wound sine and cosine potentiometers (made by Electronic Associates), accepting as inputs DC voltages A , $-A$, B , $-B$, and a rotation θ , and putting out voltages $-A \sin \theta$, $A \cos \theta$, $B \sin \theta$, and $B \cos \theta$. In order to make the operations more convenient, inverting amplifiers are provided with the servos, so that only $+A$, $+B$, and θ are required as input voltages. The sine and cosine cards are approximately 50K per quadrant and are intended to work into a 1 megohm load; they are wound to compensate for the loading due to such a load, and are accurate to .15 volts (100 volt peak) under these conditions. The quantities $(A \cos \theta + B \sin \theta)$ and $(-A \sin \theta + B \cos \theta)$ which are used in resolutions have to be formed in the REAC summing amplifiers.

A recapitulation of available servos and resolvers follows:

- 7 "A" type servo units (standard):
 - 2 servos with multipliers and functional pots.,
 - 2 servos with multipliers and resolvers.
- 6 "D" type servo units:
 - 2 servos with multipliers and
 - 2 resolvers each.
- 1 "C" type servo unit:
 - 1 servo with multipliers and 4 resolvers (C.R.).

In total, there are 42 resolvers on 27 different shaft rotations. There are 41 different shaft rotations altogether.

The laboratory also contains input and output equipment in the form of 6 recorders, 2 plotting boards and 4 input-output tables.

Figure 4 shows how the new laboratory is laid out. Basically it has been divided up into seven units (minus one REAC), each unit consisting of two REACs and two servos. One such unit is shown in Figure 5. Since the new type of servo does not permit enough room for a patch bay, extra cabinets with patch bays were provided between servo units. These cabinets also proved to be necessary for extra amplifiers used in connection with the resolvers. The three special cabinets (A105) were inserted in various locations, shown in Figure 4. Interconnections between cabinets are made by using 1) long patch cords, 2) interconnections provided between the four cabinets comprising any one unit, and 3) interconnections provided between every cabinet and one master interconsole patch bay.

The power supplies are located in a room behind the computer room; power is provided for two halves of the room separately.

Some of the regulators are in the power supply room; two of them are in the computer room. All cabling involving power leads and grounds is kept separate from the computing leads and ground. This is especially important for the relay power supply because of the relatively heavy current drawn by the relays. The relays are used to control the operation of all amplifiers, and as many REACs as desired may be used simultaneously by paralleling their relay connections and operating from one REAC.

Figure 4 also shows the layout of the other computing labs; lab 3 consisting of older computing equipment (4 REACs, 4 servos and 2 special cabinets) and lab 2, the lab for test simulation which contains one REAC, 1 auxiliary unit, some servos and several one axis roll tables which may be necessary in connection with the tester work. A system of interlab wiring has been

installed so that computing connections can be made between labs; this makes additional equipment available in any of the labs.

Figure 6 shows an overall picture of the equipment. Some problems were patched in at the time this picture was taken.

At the present time a number of improvements and additions to the laboratory are being planned and carried out. The most important item which still remains to be done is the installation of some form of flexible prepatch system with one or two master control consoles. Other items are more routine improvements which will tend to make the operation of the computers easier.

Operation

The new laboratory has been in operation since early October, 1952. As has happened before, equipment was used on problems just as fast as it became available. This has led to some difficulties when equipment had not been given a final "computer check".

Checking procedure which is considered appropriate for the equipment consists of two phases:

1. So-called Equipment Checks: routine checks of all amplifiers, servos, and potentiometers for accuracy and performance; e.g. the input resistors of amplifiers are checked for accuracy, all servos are checked for accuracy and freedom from noise, etc.
2. So-called Computing Checks: problems to which the answer is known are set up on the machine and run. In the course of these checks most troubles that escape detection in the equipment check are discovered. Due to the pressure of problems waiting to be solved this phase is frequently neglected; this means that the first problem is then solved more slowly, and with more frequent break-downs than would otherwise be expected. The acceptance check for this installation consists of a three-dimensional problem for which a numerical solution has been obtained.

Some complicated two-dimensional problems have been handled in the new laboratory. One three-dimensional problem is now being worked on, and another one or two are in preparation. One observation that has been made was that the more complex problems frequently call for the construction of special equipment which are no longer minor items when it comes to preparation

and scheduling of work. (Example: in our current flutter problem a pot panel of 196 pots is being constructed to handle a matrix of 14 x 14 coefficients.)

The project has at present a staff of 32 mathematicians, physicists and engineers at various levels. The engineering section has recently been enlarged because of the increase in engineering problems arising from more complicated problems.

The maintenance of the equipment including all three labs, and accessory equipment has required the full time service of at least two technicians. Between problems the machines are subjected to a thorough equipment check, and repairs and replacements are made, if necessary.

The problem of determining whether and when a computer solution is correct is sometimes very difficult. In making such a decision one has to know that the problem has been set up correctly and with the best scale factors possible, and whether the machine is performing properly. In the cases of problems involving many computing cabinets the difficulty involved is obvious. Two approaches are being used to get an answer to the problem of checks. One is the acquisition of a small scale general purpose digital computer for the purpose of obtaining numerical solutions for all problems for which the contractor is unable to furnish one. The other is embodied in some work now being done on error analyses for analog computers such as the REAC. At present we rely on some check solutions obtained numerically, and depend on the assumption that the solutions are continuous functions of the parameters of the equations.

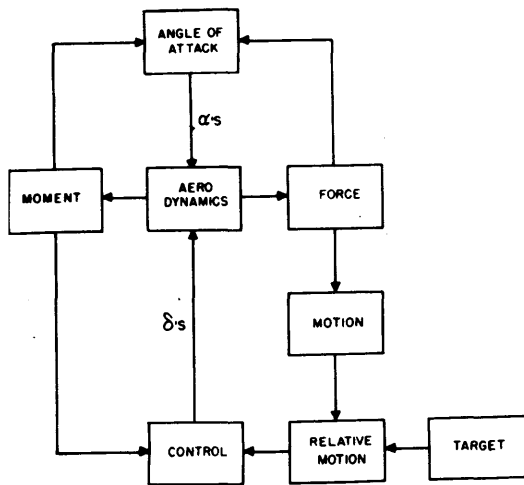

Fig. 1
Block diagram of typical guided missile problem.

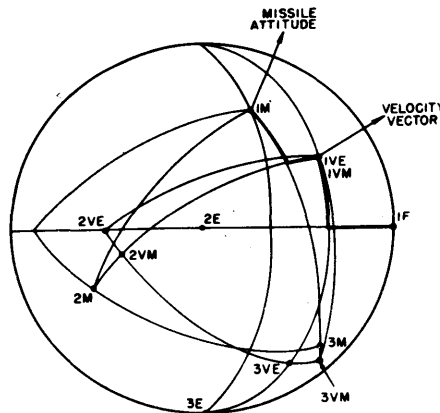

Fig. 2
Spherical Diagram showing Coordinate Systems.

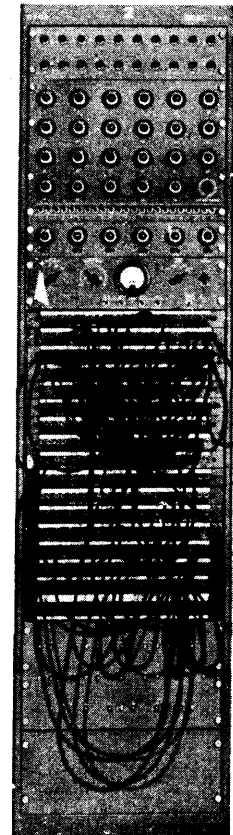

Fig. 3-REAC Computer Cabinet.

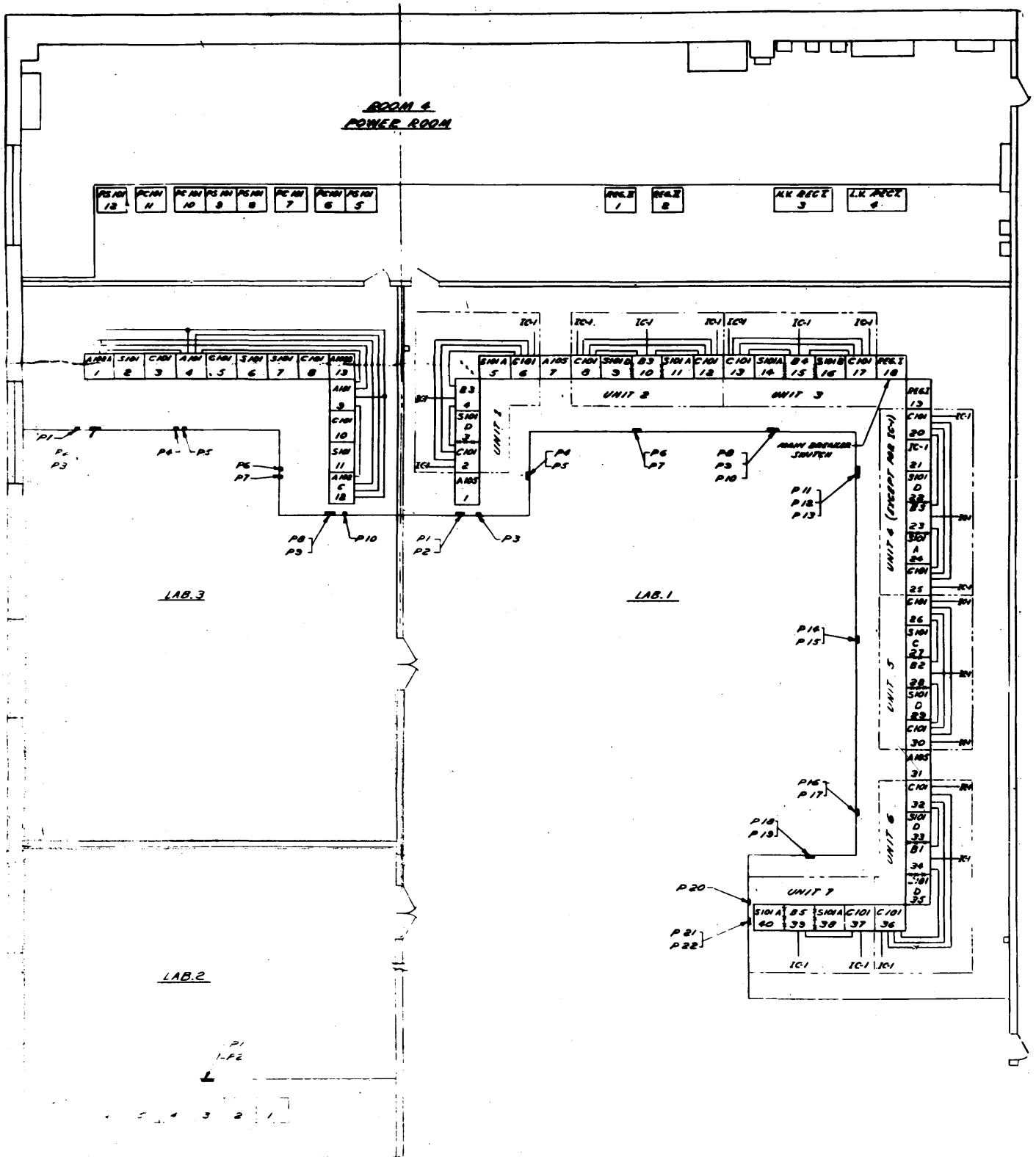

Figure 4. Layout of Laboratory.

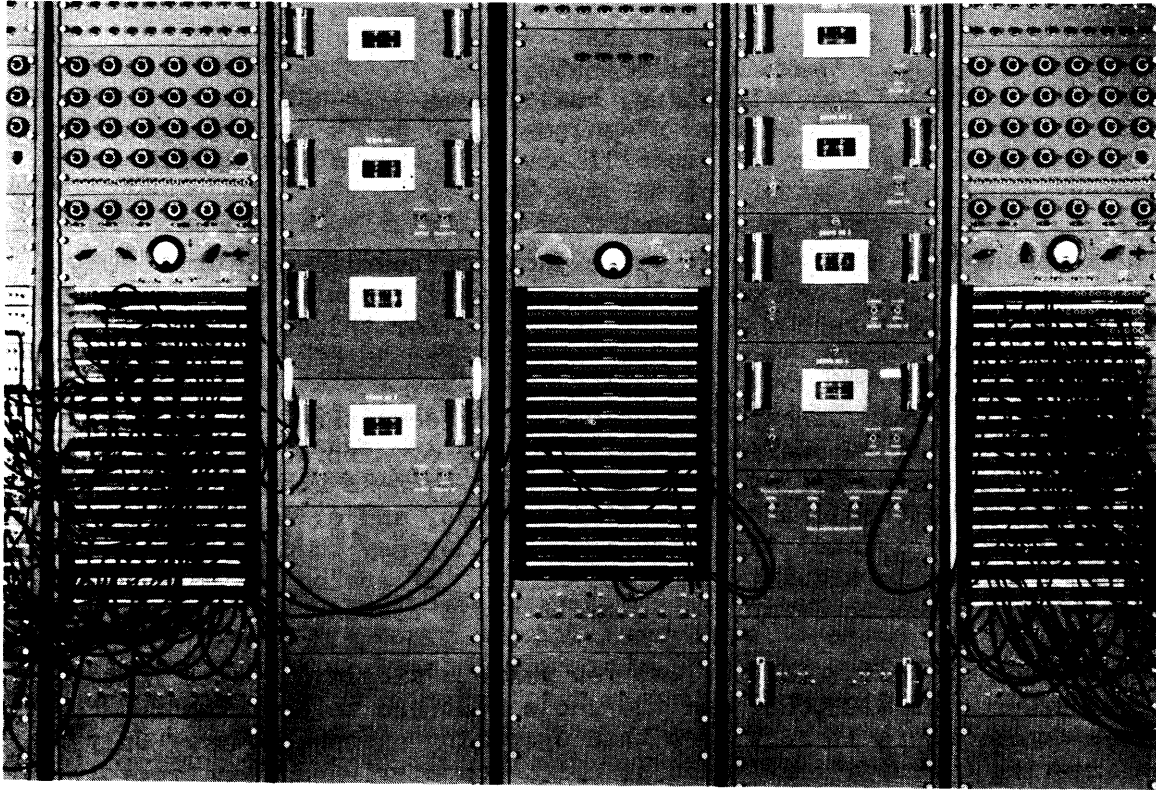

Figure 5 Computer Unit consisting of two REACs, two servo units and one servo patch bay cabinet.

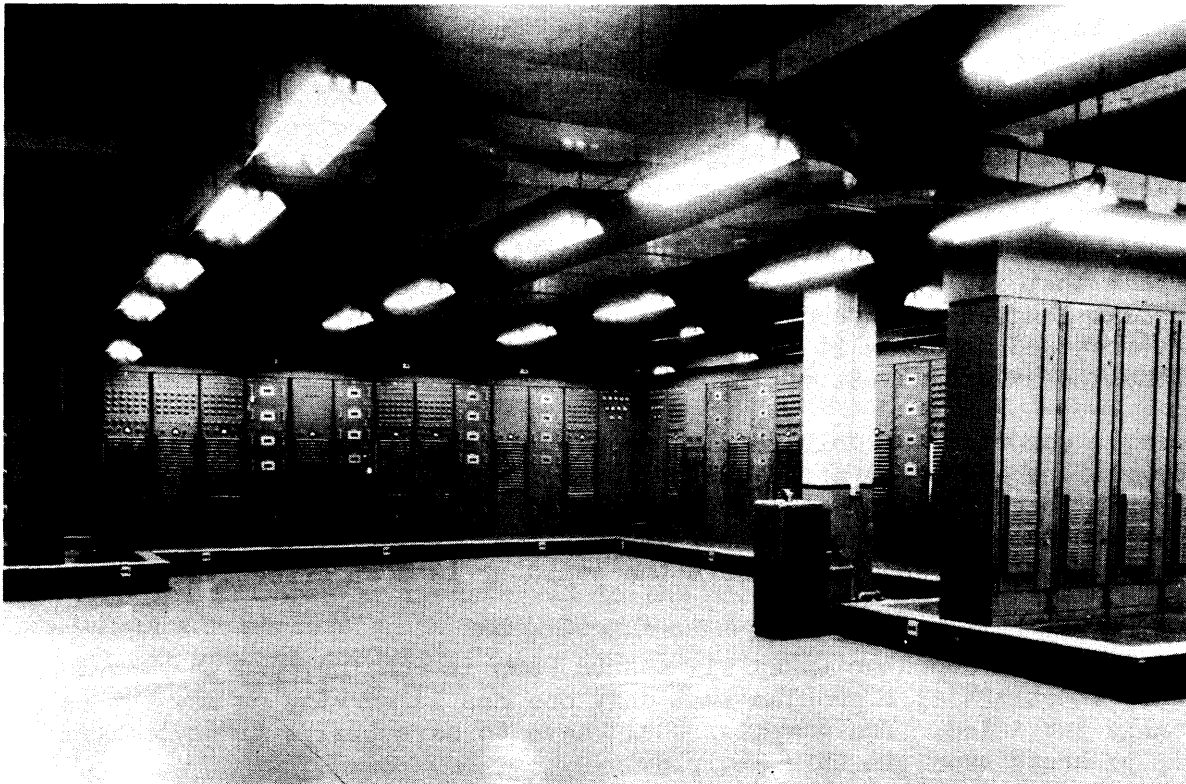

Figure 6. Photograph showing Laboratory.

A NEW CONCEPT IN ANALOG COMPUTERS

Lee Cahn
Beckman Instruments, Inc.
South Pasadena, California

1. The Pattern of Use

Analog computers can solve a wide variety of engineering problems. Why, then, doesn't every engineer use one? This paper will discuss the pattern of use of analog computers in the recent past and as the author thinks it will be in the future.

Technically, the field of application of analog computers is extensive. They may be used in studies of automatic control systems, of aircraft and missiles in flight, of electrical circuits, dynamic instruments such as accelerometers and pen recorders, of certain economic and biological systems, and of many other phenomena. They may be used in purely analytical studies, or they may be used with part of a complex physical system to simulate the rest of it. If analog computers are not widely used, lack of technical applicability is not a reason.

The big reason is cost. In the last few years a single computer installation commonly cost upwards of \$100,000, and the whole cost had to be taken from capital or facilities funds, where it hurt more than operating expense money. Only the largest engineering organizations could afford a computer, and then probably only one.

A second limiting factor has been the technical difficulty of operating a computer installation. This may be divided into two parts. First there is the computer itself. It may require special accessories, such as function generators, which have not been adequately provided by the original manufacturer. Or some of the users may be able to get better performance from the basic components than the original manufacturer did, much as hot-rod enthusiasts can do with automobiles, after half a century of development in that field. Thus many installations have found it desirable to keep computer development engineers working full time.

Second, even if the computer itself is working satisfactorily, skill is required to ascertain that it is working and to lay out and connect problems. This latter skill is like languages; anyone can learn broken English in a short time, but years are required to speak it faultlessly. An expensive installation needs a professional to make best use of its limited time.

A single computer can only handle one problem at a time. By going to multi-shift operations and other artifices the number may be raised to two or three. An engineering organization large enough to afford a computer may have dozens of problems which the computer can solve, at one time. Priority is then given to the most crucial problems, and those where the computer is most effective in saving manpower.

Indeed, if the computer takes six men to keep it running, and the wages of six more to amortize it, a problem that only one man is working on may not be economically justified. The computer would have to save twelve times the time it required, to break even, in this example.

Thus we have had a pattern of computer use characterized by the following features:

1. High cost of purchase and operation.
2. Centralized installations manned by professional computer operators and designers, to which other engineers brought their problems for solution or which were devoted to a specific set of problems. Computers generally belonged to Analysis Groups, Mathematics Groups, or Autopilot Groups.
3. Computers were only applied to a fraction of the problems where they might be applied on purely technical grounds, due to economic considerations.

A new pattern of use is developing, based on new developments in computers. Several manufacturers sell a basic but complete linear installation for less than \$8000, while a full-sized linear and non-linear unit can be had for \$15,000 or so. The new computers are generally more compact and can be moved easily from place to place. No elaborate preparations are required. They are generally quite reliable in operation, and convenient to use. Their accuracy is considerably better than most engineering work requires.

Small companies can buy these computers, where they would have no chance of buying the older designs. Large companies can have three or four or more of these for the price of one older type. More computers means that other problems than the most urgent can also be studied. Lower unit price also implies that the break-even point in terms of hours saved is much lower; that computers are economically justified for many more problems. Simulation applications, in which the computer may be tied up for long periods, benefit especially.

Another consequence of the lower price is that it is not so important to get the ultimate in efficiency of utilization. Instead of having experts, hereafter called "computer men", running the machines, they may be turned over to the engineers who need the answers, hereafter called simply "the engineers". If the engineers are not so quick as the computer men, it doesn't matter on these new computers. On the other hand, by participating in the actual operation the engineers learn a lot more about their problems than they can if they get ready-made solutions from a central facility.

The difficulties of running a computer installation are resolved differently on the new machines. There is a lot less of the hot-rod atmosphere; the new computers are generally used as built, as working tools, and are found to be adequate for their purpose, as are stock automobiles. If changes are in order, the engineering could be done once for several machines, at a lower unit cost. The emphasis is primarily on the answer rather than on the computer as a scientific tool.

The problem of teaching the engineers how to set up and operate computers is more difficult. Recent advances have been made in the literature¹. Three distinct transition patterns of training have emerged. One is simply a modification of the old pattern, in which engineers belonging to groups which will need to use the computer are temporarily transferred to the computer group and trained there as computermen for periods up to one year. When they return to their original groups they may use the computer freely and without supervision. This pattern is found in organizations which have had computers for a number of years and are used to the old pattern.

In the second type of instruction, engineers watch their problems being run by the computermen and gradually do more and more of the work. Finally the computermen drift off to more urgent work and the engineers solo.

The third pattern is found where the computer program is relatively new and based entirely on the new computers. One or two professional computermen are available for instruction and advice, but any engineer can have a computer, usually without waiting. They seem to get satisfactory results from the computers, although their knowledge of the fine points of the art certainly cannot compare with the professionals'.

A small survey was made to get some indication of the extent to which the new pattern of computer operation has spread (Table 1). Five large Southern California aircraft and missile engineering organizations were asked how many electronic computers they had, and how their computing time divided between the four types of operation:

- (a) Engineer brings his problem to computermen, who solve it for him and give him the answer.
- (b) Engineer and computerman both work together approximately equal time.
- (c) Engineer does most of the work, but has regular help from a computerman. The computerman satisfies himself that the engineer is using the computer correctly.
- (d) Engineer works alone, but may seek out a computerman for advice if he wishes.

While numerical percentages are given in some cases, they are purely qualitative estimates and do not represent actual measurements of computing time. These questions were asked for the present, for two years ago and for five years ago. The training method is given as 1, 2 or 3, where the numbers refer respectively to the methods described above.

The growth in computer use, as well as the change in pattern is dramatically shown. Every organization contacted had at least two computers. The companies concentrating on missile guidance had had computers longest, while the primarily air-frame companies had just gotten theirs.

The organizations which had computers longest had the older pattern of use, while the newer users had what I have called the newer pattern. Even in the same company, patterns differed from group to group in this way, depending on their computer-using histories. In each case this phenomenon did not appear to be the result of inertia, but rather was due to the limitations of the equipment of the older group, and to differences in function of the group.

It appears likely that organizations which have central computing groups will retain them, to handle the very complex or demanding problems where professional skill is required. Expansion, however, seems likely to occur in the direction of decentralized, inexpensive, auxiliary computers of the newer types.

2. The Computers

The circuits used in these new computers are of interest chiefly because of their effect on computer use, and as an exercise in engineering judgment, rather than because of novelty. For example, let us consider the operational amplifier.

First we see that chopper stabilization has generally been omitted. While it is true that chopper stabilization will reduce effective drift voltages by a factor of about five, this advantage has not been able to pay its way. Choppers are expensive, and their associated a.c. amplifiers are also expensive. Choppers are not distinguished for their reliability. Most important, the reduction in drift does not increase the computing accuracy accordingly. Typical values for the short term drift voltage referred to the grid, eg., are 0.1 mv for one chopper-stabilized amplifier, and 0.6 mv for a regular d.c. amplifier.* In an amplifier connected for a gain of 10, with maximum output of plus or minus 100 v., the corresponding error at the output would be

$$e_o = e_g (K_c \neq 1), \quad (1)$$

where K_c is the closed-loop gain with all input resistances paralleled, or 0.0011% of full scale for the stabilized amplifier and 0.0066% for the regular one. These errors are negligible. The critical application as far as drift goes is as an open-loop integrator. The integrators in closed-loops behave more or less as high-gain amplifiers. For the open-loop integrator with time-constant T , the drift voltage at the output is

$$e_o = e_g \frac{t}{T} \quad (2)$$

For the large values of $\frac{t}{T}$ the error voltage becomes appreciable, and is a basic limitation to the length[†] of time one can compute. For a time constant $T = 1$ sec, an output of plus or minus 100 v, and a permissible error of 0.1% = 0.1v, the maximum computing time is 1000 sec. or almost 20 minutes, for the stabilized amplifier and 160 seconds or almost 3 minutes for the regular amplifier. Within their respective maximum times, T_L , as indicated above, the two amplifiers are equal in accuracy of open-loop integration.

Long-time drift, over a period of hours, need not be a factor in the accuracy of computation, but it can be burdensome to have to rebalance amplifiers frequently. The same considerations apply as in short-term drift; drift voltage for a regular amplifier or closed-loop integrator will generally not exceed 0.1% of full scale for days. But open-loop integrators multiply the long-term drift voltage by $\frac{t}{T}$, where t is still the computing time, and may have to be rebalanced every half[†] hour or so for accurate work. Fortunately, there are relatively few open-loop integrators in most physical problems.

Thus the use of a chopper amplifier does not improve accuracy, but it does reduce the amount of rebalancing required on the open-loop integrators. It is less expensive to go over and rebalance them by hand periodically.

The new amplifiers usually have fewer vacuum tubes than the chopper amplifiers have in their d.c. portions, and obtain part of their high gain by using internal positive feedback. If the positive feedback is variable, it may be set for "infinite" gain (output voltage exists for zero grid voltage). While this sounds instinctively wrong to many engineers, it is perfectly legitimate where much larger negative feedback will also be used. High gain obtained with positive feedback does not produce as low output impedance as does the same gain obtained by using more tubes, but the usual value of 3 - 4 ohms is low enough. It does produce a better high-frequency response than using more tubes does. Fewer tubes also means fewer tubes to fail.

* Beckman EASE, Mod. A. Average absolute value of many runs.

If it is necessary to operate the regular amplifier six times as fast as the stabilized one to get equal results as far as drift is concerned, faster recording devices must be used for readout. Fortunately, they are ready to hand in the pen recorders manufactured by Sanborn, Brush and others, which have about ten times the bandwidth of the servo-driven plotting tables, and are very much less expensive.

Actually, this faster solution time is highly desirable in practice. Twenty minutes is too long to wait for most answers. Three minutes is even a little long. Many users prefer 30 to 50 seconds, to speed up their work. The only limitation in shortening the time is the range of frequencies encountered in the problem. For example, if the pen recorder begins to introduce its own dynamic response characteristics above fifty cycles per second, and the problem runs two hundred seconds, ten thousand cycles of this highest frequency component can be accommodated in the full computing time. This non-dimensional quantity appears to be a good measure of the dynamic requirements of a problem, and of the performance of a computing system, since it allows a comparison of problems and computers which may originally be on different time scales. I call it the dynamic range, R . A dynamic range R of 10,000 cycles is rather high for most practical problems; we are then considering one second and three hours in the same problem. A practical example is the phugoid oscillation of an aircraft. While only about sixty times longer than the "short-term" period, it is commonly considered to be too slow to be a problem. If R may be safely reduced, we can shorten the overall computing time to do it. If the problem runs twenty seconds with the same recorder, $R = 1000$, which is usually still pretty high.

Oscilloscopes can be used for problems which require exceptionally large values of R , since they will respond faithfully up to hundreds of kilocycles. Thus the computer itself is the ultimate limitation in the value of R which can be obtained. While nearly all present-day computers have values of R which are entirely adequate, it is still of theoretical interest to note their values. Let us consider a single amplifier, say operated with $K_c = 1.0$, with input and feedback resistances of 1.0 megohm each, and define high-frequency cutoff as occurring at the frequency f_h for which the phase shift reaches 0.01 radians. For the Beckman EASE Computer, $f_h = 400$ cps, while for a typical chopper amplifier $f_h = 40$ cps. Then using the values of T_L derived above, we define

$$R_a = f_h \cdot T_L \quad (3)$$

for a single amplifier. For the chopper amplifier $R_a = 40 \cdot 1000 = 40,000$. For the EASE amplifier, $R_a = 400 \times 160 = 64,000$. The effective R for a computing chain is less, due to the combination of many amplifiers and higher values of K_c .

The author is not aware of any problems which require such high values of R_a .

For real-time simulation it is necessary for the computer to work well over a range of definite frequencies, which are determined by the system being simulated. A three minute period is generally adequate for this work. At the high frequency end, amplifier bandwidth is not usually the limitation; it is the auxiliary equipment. Servo multipliers and function generators restrict the older computers to 2 - 10 cps maximum; many systems being simulated have higher bandwidths. While a satisfactory value of R_a may be maintained by running very slowly, this artifice does not help in real-time work.

Besides being slow, the mechanical devices are quite expensive. The EASE computer uses electronic multipliers and function generators, which are usable beyond 100 cps, and, being entirely electronic, cost much less. Somewhat similar circuits are used by others. Multiplication is accomplished by controlling the duration of a high-repetition-rate pulse with one voltage, and its magnitude with a second voltage. The average component is proportional to the product of the two. The high-frequency components must be filtered out, and the filter will then have some phase shift at signal frequencies; say 15° at 100 cps.

Functions are generated by diode switches which connect bridge circuits so as to produce line segments of controllable incremental slope. These are stable and repeatable to a fraction of a volt in plus or minus 100 v.

Thus the older computers are characterized by electromechanical components, operation often slower than real time, and the consequent need for very low drift amplifiers regardless of cost. The newer ones are all electronic, can operate as fast or faster than real time for many applications, and operate fast enough to eliminate the effect of drift without requiring stabilization. Each of these characteristics reduces the cost for the new ones.

That is how the manufacturers can produce a better computer for less.

References

1. Korn and Korn, "Electronic Analog Computers".

COMPANY

A

B

C

D

E

When?	-5 yrs.	-2 yrs.	Now	-5 yrs.	-2 yrs.	Now	-5 yrs.	-2 yrs.	Now	-5 yrs.	-2 yrs.	Now	-5 yrs.	-2 yrs.	Now		
How many computers?	1	2	9	0	0	(2) 2	0	2	3	0	0	(5) 2	0	0	9		
Computer groups and no. of computers in each	Group No. 1-1	Group No. 1-2	Group No. 1-5	Group No. 2-3	Group 3-1					Group No. 1-2	Group No. 1-2	Group 2-1			Group No. 1-1	Group 2-1	Group No. 1-9
Use pattern-% of computing time																	
a. Computermen only	0	50	10	0	10	5		(3) 100	0	(4)			80	20			0
b. Engineers and computermen equal time	0	50	85	0	30	90		0	0				20	80			0
c. Engineers with some assistance from computermen	0	0	5	0	30	5		0		100%			0	0			100%
d. Engineers only	(1) 100	0	0	100	30	0		0					0	0			100%
Training method indicated. See page 4	(1)	1	1	3		2		1	1								3
	(1) Only one man				(2) Equipment fairly new			(3) Training (4) Equipment too recent to say			(5) Both machines very recent						

A MAGNETICALLY COUPLED LOW-COST HIGH-SPEED
SHAFT POSITION DIGITIZER

Arthur J. Winter
Telecomputing Corporation
Burbank, California

The outputs of many precision devices occur as shaft rotations. When the position of such a shaft must be determined to an accuracy beyond the reach of analog instruments, or when the data has to be processed by digital equipment, an analog to digital conversion must be made. It is nearly always desirable and often essential that the digitizer present no appreciable mechanical load to the shaft under measurement. A further requirement which often must be met is that readings be taken on the fly. That is, positional information may be called for when the shaft is in motion at speeds that may vary from zero to many hundreds of rpm.

Present day needs for angle digitizing devices often call for accuracies and resolutions in excess of 1000 parts per revolution. In radar and optical tracking systems, for instance, it would be desirable to digitize the circle into 64,000 parts. Whenever such high resolutions are needed it is common practice to gear up the output shaft to drive the digitizer. The disadvantages of this are obvious. Gears of such high accuracy are very expensive and add friction and inertia to the system. For this reason the basic digitizer, without gearing, should have as high a resolution as possible.

This paper deals with a recently developed shaft position digitizer which was designed to more nearly satisfy the requirements above. Two previous types which led to its development will be discussed first.

An early type of digitizer, the slotted disc, is shown in Figure 1. This is, as the name implies, a device in which a disc is rotated so that a light beam is interrupted by teeth on its periphery. A photoelectric cell pickup and d-c amplifier produce an output signal which varies in amplitude from maximum to minimum each time the light beam is interrupted by a tooth. If this signal is fed through a d-c operated trigger into a counter, the counter will accumulate angular increments by counting the number of teeth. By using another photocell angularly separated from the first by an amount equal to one-half of a slot, an additional signal is derived which is in phase quadrature with the first. Since the phase relationship between the two signals changes with direction of rotation, the second signal may be used to prepare gates in the accumulator which cause the counters to subtract when the digitizer reverses direction. In this way the digitizer can be used on a shaft which may hunt, oscillate, or reverse direction, without introducing errors into the accumulator. By the use of proper circuitry in the counters, readouts may be obtained on the fly without stopping the digitizer or losing the count in the accumulator.

The slotted disc digitizer is limited in resolution by the number of slots that it is possible to cut in any given diameter disc, and therefore it has been used only for applications requiring resolution of about 200 counts per revolution or less.

The next to be developed was a serrated drum digitizer (Figure 2). In this type the slotted disc was replaced by a drum with many serrations on its surface. These serrations acted as concave mirrors which reflected the light into two photocells, as shown in Figure 3. The output from the photocells is amplified and handled in the same way as in the case of the slotted disc digitizer. The advantage of the serrated drum over the slotted disc is that more serrations can be machined in a given diameter drum than slots could be cut in the same diameter disc. However, since the light output is not as great, photocell and amplifier drifts are more of a problem.

The magnetic shaft position digitizer was designed to overcome certain disadvantages in the two previous types just discussed. The magnetic digitizer has higher resolution, that is more counts per revolution. It is free from drifts due to photocells and d-c amplifiers. It is much more rugged and reliable.

The basic principles of operation can be explained by referring to Figure 4. A high frequency generator causes a current to flow through a conductor which is shaped in such a way that at any instant the current flow in adjacent parallel segments of the conductor are 180° out of phase. The arrows indicate polarity of current flow at some instant of time. If a device which could indicate the presence of an electromagnetic field were placed directly over any one of the conducting segments, such as A or C, it would measure the intensity of the field near that segment; and if the same indicator were placed halfway between two adjacent segments, position B, its output would be essentially zero.

This can actually be done with a small pickup coil held over one segment; and if the output of the pickup is amplified and demodulated, the resultant d-c output signal will fluctuate from maximum to null as the pickup coil is moved across conductor segments. In this way d-c signals are derived which are a function of position. Fluctuations in these signals can be used to count the number of segments. To obtain two outputs for direction sensing as in the previous digitizer, two pickups must be used, spaced one-quarter of a segment apart.

In order to adapt this principle to shaft digitizing, the conducting pattern of Figure 4 was arranged in the circular pattern shown in Figure 5. This is an actual negative of a 500 segment pattern which is photoetched onto a 2 1/2 inch disc and used as the rotating element of a shaft position digitizer. The connections at the center are for injection of the high frequency carrier current. In order to avoid using slip rings, the carrier current is coupled to the rotor by means of a small air core transformer whose secondary is mounted on the rotor and spins with it.

Instead of a pickup device consisting of a coil over one segment, the arrangement in Figure 6 is used. This pickup pattern is the same as the rotor pattern; and it functions in the same way as the pickup coil would except that there is coupling to every segment in the rotor, and the output signal is a much more accurate indication of position, since each null and each maximum results from an average of all of the conducting segments. The pickup pattern is also photoetched on a disc and consists of two conductors displaced angularly one-quarter of a segment space. There are three connections at the

outer edge; one is a common ground, the other two go to their respective amplifiers.

Figure 7 shows the configuration of the assembled digitizer. The rotor spins with the shaft along with the inner coil, the secondary, of the coupling transformer. The outer coil, the primary, connects to an oscillator which supplies the carrier signal. The frequency of this oscillator in the digitizers currently being built is 1.6 megacycles. The pickup, or stator, supplies signals to two tuned amplifiers. These signals are demodulated and the resultant d-c output can be used to count increments of rotation as in the previous digitizers.

Figure 8 is a photograph of a magnetic shaft position digitizer with a resolution of 1000 counts per revolution. It has a permissible shaft speed of from zero to 1800 rpm; and since its output contains directional information, it can reverse direction or hunt, as in the case of the slotted disc and serrated drum types, without introducing errors.

The advantages of this digitizer over the previous types are:

- 1) The photoetching process makes it possible to obtain more counts per revolution. Digitizers of 1000 and 2000 counts per revolution have been built.
- 2) It is electrically more stable and not subject to drifts since it is an a-c carrier operated nulling device.
- 3) It is less subject to stray electrical pickups because of its low impedance and tuned circuits.
- 4) It is more rugged and more reliable.
- 5) The smaller rotor disc presents less of an inertial load to the shaft.

Another advantage, and one which has not yet been fully exploited, is the averaging effect of the pickup element. The position of the exact point on the circle at which the output goes through any given null is at least an order of magnitude more accurate than it would be if the signal were derived from a pickup over only one rotor segment. Development is now under way to take advantage of this potentially high accuracy by electrically dividing the increments between nulls so that the number of counts per revolution may be multiplied many times.

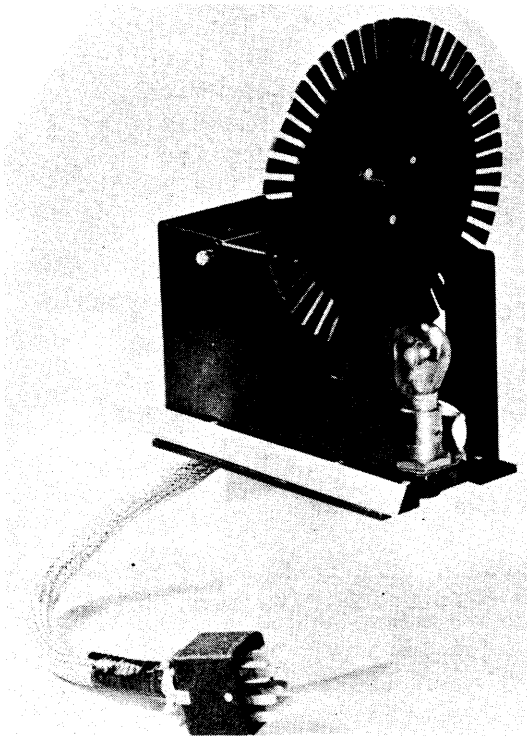

FIGURE 1 SLOTTED
DISK SHAFT POSITION DIGITIZER

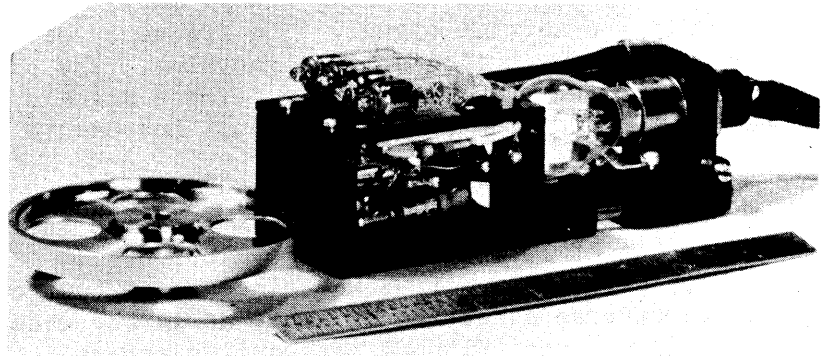

FIGURE 2 SERRATED
DRUM SHAFT POSITION DIGITIZER

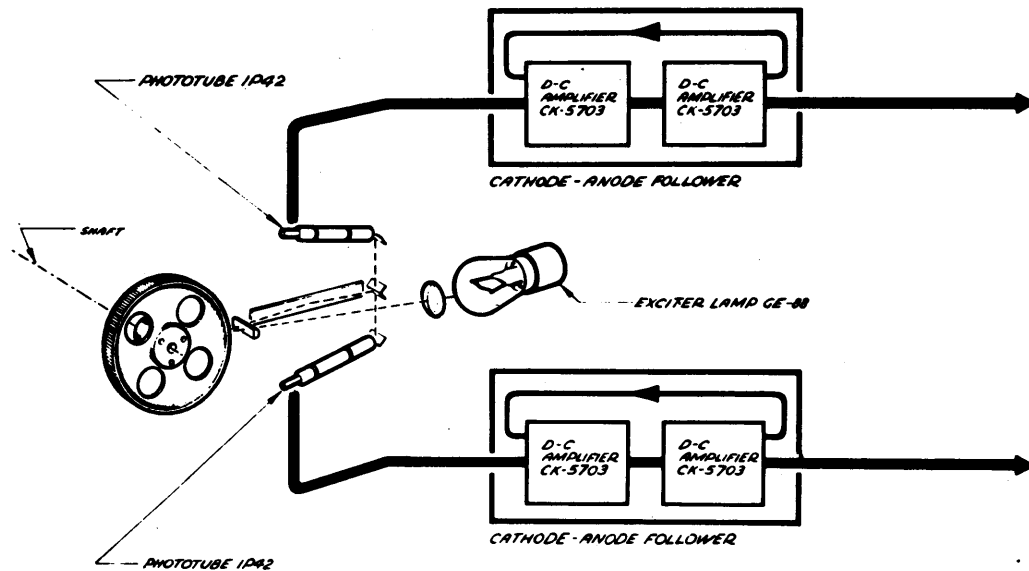

FIGURE 3 SERRATED
DRUM SHAFT POSITION DIGITIZER

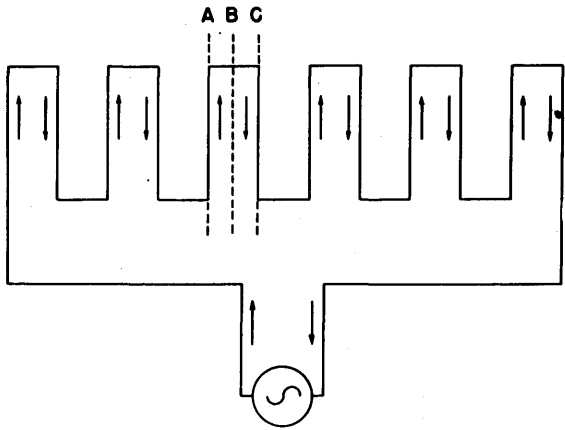

FIGURE 4 MAGNETIC FIELD FOR POSITION DIGITIZING

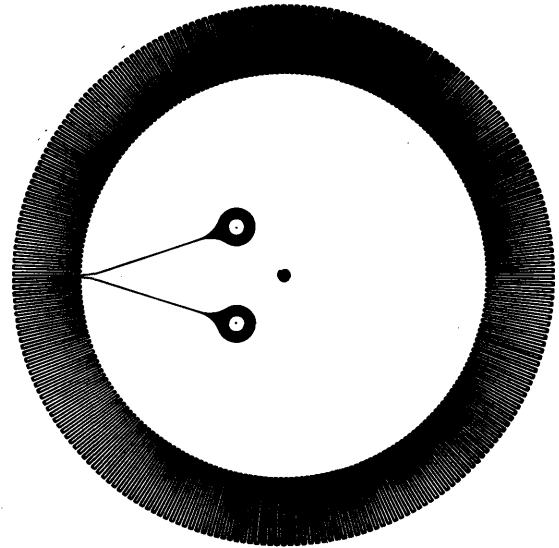

FIGURE 5 ROTOR FOR MAGNETIC SHAFT POSITION DIGITIZER

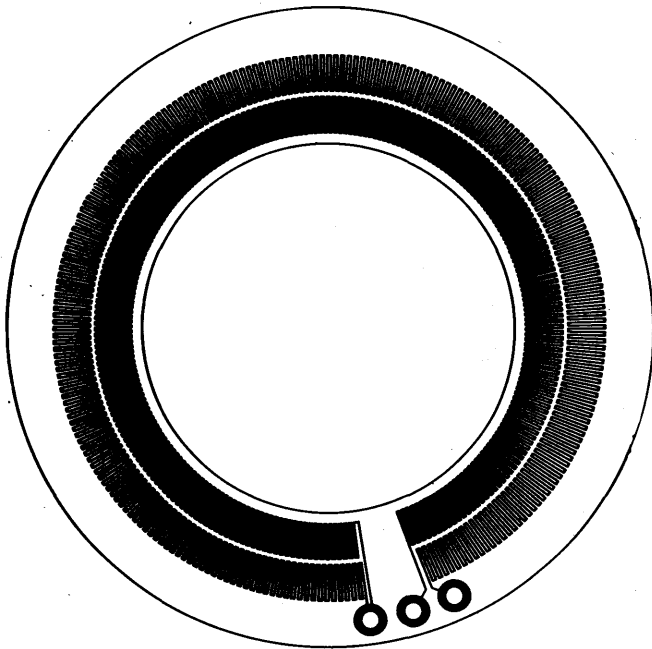

FIGURE 6 PICKUP FOR MAGNETIC SHAFT POSITION DIGITIZER

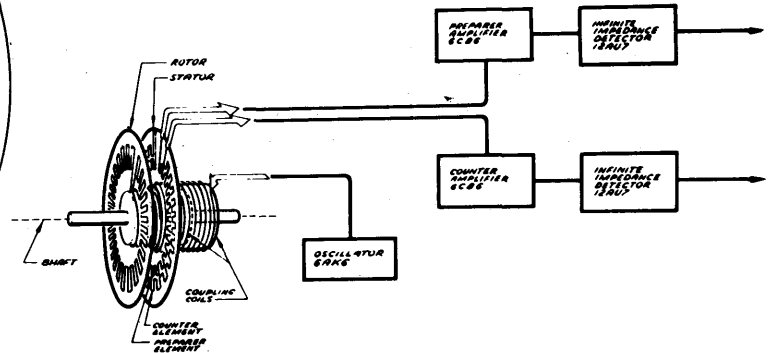

FIGURE 7 MAGNETIC SHAFT POSITION DIGITIZER

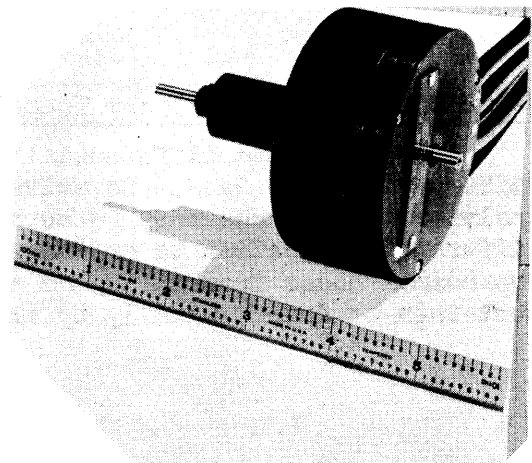

FIGURE 8 MAGNETIC SHAFT POSITION DIGITIZER

THE SOLUTION OF PARTIAL DIFFERENTIAL EQUATIONS
BY DIFFERENCE METHODS USING THE ELECTRONIC DIFFERENTIAL ANALYZER

R. M. Howe
Assistant Professor of Aeronautical Engineering
University of Michigan
Ann Arbor, Michigan

and

V. S. Haneman
Captain, U.S.A.F.
formerly Research Engineer
University of Michigan
Ann Arbor, Michigan

Abstract

Partial differential equations can be approximated by systems of simultaneous ordinary differential equations by replacing one or more of the partial derivatives by the appropriate finite differences. The resulting systems of equations can sometimes be solved directly by an electric analog computer employing passive circuits (e.g. the Caltech analog computer), or by an electronic differential analyzer employing feedback amplifiers (e.g. the Reeves Electronic Analog Computer). The latter type of computer has several important advantages, including versatility, ability to handle nonlinear partial differential equations, and flexibility in selecting time scales. Both theoretical analysis of the accuracies attainable with the difference method and actual solution examples using the electronic differential analyzer are described. Types of partial differential equations considered include the heat, wave, and beam equations. Real-time simulation of aircraft structures is discussed.

The actual computer solutions were carried out on the electronic differential analyzer of the Department of Aeronautical Engineering. As a result of the promise shown by the difference method discussed in this report, construction of an 80-amplifier analyzer has begun.

INTRODUCTION

Usual Differential Analyzer Technique for Solving Partial Differential Equations

The electronic differential analyzer is limited to the solution of ordinary differential equations. To solve a linear partial differential equation on the analyzer, it is necessary to separate variables and hence convert the partial differential equation to ordinary differential equations of the eigenvalue type. The normal modes from which the solution to the original problem can be built up must then be found, usually by trial and error techniques.

The above method of separating variables and obtaining a series type of solution can be carried out fairly efficiently on an electronic differential analyzer.^{1,2,3} Certainly, for most problems the analyzer is much faster than any hand methods. But for the engineer who is interested in getting numerical answers to specific problems, even the analyzer approach might seem somewhat tedious. It therefore would be highly advantageous to be able to solve the partial differential equations directly. This can be done by replacing some of the partial derivatives by finite differences in order to convert the original partial differential equation into a system of ordinary differential equations.⁴

Replacement of Partial Derivatives by Finite Differences

Assume we are interested in solving a partial differential equation in which the dependent variable $y(x,t)$ is a function of both a distance variable x and a time variable t . Instead of measuring the variable y at all distances x , let us measure y only at certain stations along x ; thus, let y_1 be the value of y at the first x station, y_2 be the value of y at the second x station, y_n be the value of y at the n th x station. Further, let the distance between stations be a constant Δx .

Now clearly a good approximation to $\frac{\partial y}{\partial x} \Big|_{1/2}$ (i.e., the partial derivative of y with respect to x at the $1/2$ station) is given by the difference

$$\frac{\partial y}{\partial x} \Big|_{1/2} = \frac{y_1 - y_0}{\Delta x} \quad (1)$$

In fact the limit of Equation 1 as $\Delta x \rightarrow 0$ is just the definition of the partial derivative at that point. Writing Equation 1 in more general terms

$$\frac{\partial y}{\partial x} \Big|_{n-1/2} = \frac{y_n - y_{n-1}}{\Delta x} \quad (2)$$

In the same way

$$\frac{\partial^2 y}{\partial x^2} \Big|_n = \frac{1}{\Delta x} \left\{ \frac{\partial y}{\partial x} \Big|_{n+1/2} - \frac{\partial y}{\partial x} \Big|_{n-1/2} \right\} = \frac{y_{n+1} - 2y_n + y_{n-1}}{(\Delta x)^2} \quad (3)$$

Similarly

$$\frac{\partial^3 y}{\partial x^3} \Big|_{n-1/2} = \frac{y_{n+1} - 3y_n + 3y_{n-1} - y_{n-2}}{(\Delta x)^3} \quad (4)$$

Thus we have converted partial derivatives with respect to x into algebraic differences. The only differential needed now is with respect to the time variable t , so that we are left with a system of ordinary differential equations involving dependent variables $y_0(t), y_1(t), \dots, y_n(t), \dots$

SOLUTION OF THE HEAT EQUATION

Equation to be Solved

As a first example of a partial differential equation, let us consider the equation of heat flow through a continuous medium, since it involves second order spatial derivatives and only first order time derivatives. The basic heat equation is given by

$$C\delta \frac{\partial u}{\partial t} = \nabla \cdot K \nabla u + f \quad (5)$$

where

u = temperature and is a function of the spatial coordinates and time,

K = thermal conductivity, in general a function of the spatial coordinates,

C = specific heat, a function of spatial coordinates,

δ = density, also a function of spatial coordinates,

t = time,

f = rate of heat supplied by sources in the medium, a function of spatial coordinates and time.

The actual heat flow or flux due to conduction normal to any unit surface is given by $-K \nabla u$ (component of ∇u normal to the surface). Thus the heat flux F_x across a unit surface normal to the x direction is given by

$$F_x = -K \frac{\partial u}{\partial x} \quad (6)$$

In a given heat flow problem it is necessary to stipulate spatial boundary conditions either on the temperature u or the heat flow $-K\nabla u$, as well as initial temperature distribution throughout the medium.

Derivation of the Difference Equations

For simplicity in illustrating the application of difference techniques, let us assume that spatial variations in the temperature u are confined to the x direction. Equation 5 then becomes

$$C(x) \frac{\partial u(x,t)}{\partial t} = \frac{\partial}{\partial x} \left[K(x) \frac{\partial u(x,t)}{\partial x} \right] + f(x,t) \quad (7)$$

where we have let

$$C(x) = c(x) \delta(x) \quad (8)$$

This could represent the temperature distribution in a medium between two infinite slabs.

Following the technique discussed in Section I, we will consider only values of u at certain equally spaced stations along the x coordinate axis. Thus $u(x, t)$ is replaced by $u_1(t), u_2(t), \dots$ etc. If Δx is the distance between stations, we can write for the heat flux $F_{n-1/2}$ at the $n-1/2$ station

$$F_{n-1/2} = -k \left. \frac{\partial u}{\partial x} \right|_{n-1/2} = - \frac{k_{n-1/2}}{\Delta x} (u_n - u_{n-1}) . \quad (9)$$

We can now write the equation of heat-flow balance at the n th station. Thus

$$C_n \frac{du_n}{dt} = \frac{k_{n+1/2}}{(\Delta x)^2} (u_{n+1} - u_n) - \frac{k_{n-1/2}}{(\Delta x)^2} (u_n - u_{n-1}) + f_n \quad (10)$$

where C_n is the heat capacity at the n th station and f_n is the rate of heat supplied by a heat source at the n th station (f_n will in general be a function of time). Note that du_n/dt is now a total derivative and not a partial derivative, since by definition x remains fixed while we take du_n/dt .

Equation 10 will be iterated for different values of n until the boundaries in x are reached, at which point it is necessary to impose boundary conditions.

Imposing Boundary Conditions

Suppose that one of the boundary conditions specifies the temperature at $x = 0$ (i.e., at the zero station). Then we have

$$u_0 = \text{constant}$$

and hence

$$F_{1/2} = \frac{k_{1/2}}{x} [u_1(t) - u_0] . \quad (11)$$

All we have done in imposing the boundary condition, then, is to fix $u_0(t)$ at a constant value of u_0 .

If the temperature is specified at $x = L$ (i.e., at the N th station, where $N = L/\Delta x$), then for $u_N(t)$ we substitute $u_N = \text{constant}$, the desired temperature.

Often a condition is placed on the rate of heat flowing past a boundary, either that this flow be zero (as for an insulating boundary) or a constant. Suppose we let

$$F_{1/2} = \text{constant}.$$

Then the equation for the first station is

$$C_1 \frac{du_1(t)}{dt} = \frac{k_{3/2}}{(\Delta x)^2} [u_2(t) - u_1(t)] + \frac{F_{1/2}}{\Delta x} + f_1(t) . \quad (12)$$

The equations for u_2, u_3, \dots are the same as usual. If we desire $F_{N+1/2} = \text{constant}$ as a boundary condition, then the equation for the Nth station is similar.

The process of setting in boundary conditions is evidently quite straightforward. Notice, however, that when we denote temperature at integral stations, the boundary occurs at an integral station when temperature at the boundary is specified, whereas the boundary occurs at a half-integral station when the heat flow at the boundary is specified.

Imposing Initial Conditions

In addition to specifying boundary conditions in this type of heat problem, it is necessary to specify the initial temperature distribution in our medium. Thus we have

$$\begin{aligned}
 u_1(0) &= U_1 \\
 u_2(0) &= U_2 \\
 u_3(0) &= U_3 \\
 &\vdots \\
 &\vdots \\
 u_N(0) &= U_N
 \end{aligned}
 \tag{13}$$

These initial conditions must then be imposed on the electronic differential analyzer.

Complete Differential Difference Equations for a Given Set of Boundary Conditions

For purposes of illustration, let us assume that the boundary conditions of our conducting slab are that at $x = 0$ the temperature remains fixed at u_0 , and at $x = L \doteq \Delta x(N+1/2)$ the heat flow is zero. The space between $x = 0$ and $x = L$ is therefore broken into N cells, and from Equations 10, 11, and 12 we can write the complete set of differential equations.

The initial conditions specify the temperature for each station at $t = 0$. A schematic diagram showing all the locations relative to the conducting slab is shown in Figure 1 for $N = 10$.

In Figure 2 the computer arrangement for solving the difference equation is shown. Note that the outputs of each successive row of amplifiers are reversed. This allows the necessary differences to be taken without sign-reversing amplifiers. Note also that the heat flow or flux F is available at any half-station as a dependent variable. Thus the temperature u and heat flux F across the slab can be observed directly as a function of time.

It is possible to reduce the number of amplifiers from three to one per station. In many ways, however, the circuit of Figure 2 is simpler despite the increased number of amplifiers. To change the conductivity K or heat capacity C at any station, only the appropriate resistor has to be varied. Initial temperature distribution across the slab is changed by setting the U_1, U_2, \dots, U_N voltages to the desired values. The heat sources through the slab are represented by the voltages f_1, f_2, \dots, f_N which may be varied as a function of time in any desired manner.

Solution by Separation of Variables

In order to evaluate the accuracy of the difference technique, it is worth while to solve the partial differential equations of heat flow by separating variables. For simplicity we will solve the problem of the temperature distribution between two infinite slabs held at a temperature of zero. Assume that the medium has constant conductivity K and constant specific heat capacity c . Also assume no heat sources within the medium. Then from Equation 7

$$\frac{\partial}{\partial x} \frac{\partial u}{\partial x} = \frac{\partial^2 u}{\partial x^2} \quad (14)$$

The boundary conditions are

$$u(0,t) = u(L,t) = 0 \quad (15)$$

Let us assume as a simple initial condition that the temperature in the medium is everywhere constant at $t = 0$. Thus

$$u(x,0) = U = \text{constant} \quad (16)$$

The complete solution can be written in the series form

$$u(x,t) = \frac{4U}{\pi} \sum_{n=1}^{\infty} \frac{1}{n} \sin \frac{(n)\pi x}{L} e^{-\frac{K}{c\delta} \frac{(n)^2 \pi^2}{L^2} t} \quad (17)$$

($n = 1, 3, 5, \dots$)

This solution actually represents an infinite number of sinusoidal temperature distributions across the medium from $x = 0$ to $x = L$. At $t = 0$ the sine waves all add up to give the initial flat temperature distribution. For $t > 0$ the sine waves decay exponentially at different rates, with the decay rate faster for those sine waves having more nodes and loops. The resulting temperature distribution at various times is plotted in Figure 3, where a dimensionless time variable γ has been used. γ is defined as

$$\gamma = \frac{K}{c\delta L^2} t \quad (18)$$

Thus Figure 3 is independent of the physical constants of the problem.

We will now proceed to calculate the decay-time constants for the normal modes of the difference equation representation. If these agree well with the decay-time constants in the solution above, and if the equivalent normal modes show good agreement with sine waves, then we can expect accurate results using the difference technique.

Solution of the Difference Equation for N Cells

When the space between $x = 0$ and $x = L$ is broken up into N cells, the general difference equation is given by Equation 10. At station 1 and station $N-1$ the difference equation is obtained by setting u_0 and u_N equal to zero respectively. In the problem under consideration the conductivity K and specific heat capacity C are constant. By proper choice of our distance variable x we can make $\Delta x = 1$, so that $L = N\Delta x = N$. By proper choice of our time variable t we can make $C/K = 1$ so that for $f = 0$ Equation 10 becomes for the i th cell.

$$\dot{u}_i = u_{i+1} - 2u_i + u_{i-1} . \quad (19)$$

To solve for the normal modes we assume that the i th temperature u_i varies with time as $a_i e^{-\lambda t}$, where a_i is a constant. If this is true, then Equation 19 becomes a set of $N-1$ simultaneous algebraic equations. The only nontrivial solution of the equations is obtained when the determinant of the coefficient vanishes. This determinant, when expanded, becomes a polynomial in λ of order $N-1$. The polynomial will have $N-1$ positive roots λ_n which are the decay constants for our N cell system. To solve this determinant for a specific N is very tedious, and to solve it in general would be next to impossible. The roots λ_n can be found much more easily by the following procedure:

Assume that the spatial mode shape for the difference equations is the same as for the continuous equation, i.e., sinusoidal. If this is true, then for the temperature u_i at the i th station we have

$$u_i = a \sin \frac{n\pi i}{N} e^{-\lambda_n t} . \quad (20)$$

From simple trigonometry it follows that

$$u_{i+1} + u_{i-1} = 2a \sin \frac{n\pi i}{N} \cos \frac{n\pi}{N} . \quad (21)$$

From Equation 19 we have for the i th station

$$(2 - \lambda_n) \sin \frac{n\pi i}{N} e^{-\lambda_n t} = 2 \sin \frac{n\pi i}{N} \cos \frac{n\pi}{N} e^{-\lambda_n t}$$

from which

$$\lambda_n = 2(1 - \cos \frac{n\pi}{N}) . \quad (22)$$

It is easy to show that Equation 20 satisfies the boundary conditions. Thus, our assumed solution is the exact solution, where the decay constants λ_n are given by Equation 22. Expanding Equation 22 in a power series, we have

$$\lambda_n = \left(\frac{n\pi}{N}\right)^2 \left[1 - \frac{1}{12} \left(\frac{n\pi}{N}\right)^2 + \dots \right] \quad (23)$$

In the limit of infinitely many cells the λ_n equation given above reduces to the decay constants in Equation 17, since here $L = N\Delta x = N$ and $\frac{K}{\rho\delta} = 1$.

In Figure 4 the percentage deviation in decay constant due to the difference method as a function of the number of cells N is shown. Note that the lower modes (lower values of n) require fewer cells to give accurate decay constants.

To summarize, we see that when the spatial derivatives of the heat equation are replaced by finite difference, the resulting normal mode shapes agree exactly, whereas the decay constants (eigenvalues) for each mode are somewhat smaller. This means that the higher modes will decay somewhat slower when the differential difference equation approximation is used. The error is bigger for higher modes, but fortunately the higher modes are generally much less important.

Computer Solution for One-Dimensional Heat Flow

We now proceed to the computer solution of the one-dimensional heat flow problem considered in the last section, namely the temperature distribution between two infinite slabs a distance L apart and with boundaries held at zero temperature. We can select the distance variable so that $\Delta x = 1$ and hence $L = N\Delta x = N$, where N is the number of cells. After proper choice of the units of time t so that $K/\rho\delta = 1$, the basic heat equation becomes from Equation 14

$$\frac{\partial u}{\partial t} = \frac{\partial^2 u}{\partial x^2} \quad (24)$$

which in terms of a difference equation is

$$\frac{du_n}{dt} = u_{n+1} - 2u_n + u_{n-1} \quad (25)$$

For the problem in Section II the initial temperature distribution was a constant U . Thus, we have the initial conditions

$$u_n(0) = U = \text{constant} \quad (26)$$

Boundary conditions are

$$u_0 = u_N = 0 \quad (27)$$

This heat problem was solved with the differential analyzer for 9 cells.

In order to compare the computer results with the solution shown in Figure 3 for a continuous medium, we must convert our computer time units to the dimensionless units of Figure 3. Remembering that we chose computer time units so that $K/c\delta = 1$, we have from Equation 18

$$\tau = \frac{1}{L^2} t = \frac{1}{N^2} t \quad (28)$$

Thus for our 9-cell problem we divide computer time t by 81 to obtain the dimensionless time τ of Figure 3. In this way points from the computer solution are compared in Figure 3 with the theoretical solution for a continuous medium. The correlation is evidently quite good, as we could have predicted from our theoretical work in Section II.

Since our initial temperature distribution is symmetric about the station $4-1/2$, as are our boundary conditions, the temperature distribution remains symmetrical as a function of time. Therefore, the heat flow will be zero at station $4-1/2$, and the appropriate boundary condition can be established there. If this is done, it is only necessary to solve the problem half-way across the distance between the slabs, the solution for the other half being symmetrical.

In the same way, if the initial temperature distribution in our homogeneous medium had been antisymmetrical with respect to station $4-1/2$, we could have treated the problem for N cells by setting $u_0 = u_{N/2} = 0$ and solving the $N/2$ -cell problem. Here we must obviously have an even number of cells to begin with, whereas in the symmetrical case we needed an odd number of cells.

It is evident that by considering symmetry effects the number of amplifiers needed may often be cut in half. Furthermore, any arbitrary initial temperature distribution can always be split into a symmetrical and antisymmetrical form. The solution for each of these initial distributions can then be found, and since the equations are linear, the final solution is the sum of the two solutions. Of course this procedure will only work when the conductivity K and the specific heat capacity $c\delta$ for the medium are constant or symmetrical about the center of the medium. Also, the boundary conditions must be symmetrical.

Summary of Investigation of the Use of Difference Techniques for the Heat Equation

We have shown that it is both simple and straightforward to solve the heat equation with the electronic differential analyzer by replacing spatial derivatives with finite differences. Normal mode shapes show exact agreement with those calculated by separation of variables for the simple problems considered. Decay constants corresponding to the various modes also show good agreement but tend to be somewhat lower than the values calculated by separation of variables, particularly for higher modes or if fewer cells are used. For most engineering problems the order of eight to sixteen cells per spatial dimension should be completely adequate (see Figure 4).

Only one operational amplifier is needed per cell, although in some problems it may be more convenient to use three amplifiers per cell. The problem is completely stable, and the final outputs of the computer are temperature and heat flow as a function of spatial coordinates and time.

SOLUTION OF THE WAVE EQUATION

Equation to be Solved

One of the most important partial differential equations met in engineering is the wave equation. If we let ϕ represent the magnitude of a disturbance in any medium in which wave propagation can take place, then we can write the wave equation as

$$\nabla^2 \phi = \frac{1}{v^2} \frac{\partial^2 \phi}{\partial t^2} \quad (29)$$

Here v is the wave velocity in the medium and t is the time variable. Equation 29 must of course be subject to spatial boundary conditions and initial time conditions.

The spatial derivatives of the wave equation have exactly the same form as the heat equation, but the time derivative is second order instead of first order. The difference techniques for converting the partial differential equation to system of ordinary differential equations in time are also practically identical. Space does not permit discussion of specific examples, but it may be remarked that application of the method to the problem of a vibrating string has given satisfactory results.

The solution of the wave equation by difference methods is easily performed by the differential analyzer when the medium of propagation is non-uniform. Also, the effect of damping forces can readily be included.

Thus far we have considered partial differential equations with boundary conditions occurring a finite distance apart. It seems evident that our difference techniques as used here are limited to this type of equation. Thus, it would not seem possible to solve problems in semi-infinite or infinite media unless one can let the time variable in the computer represent the spatial variable which goes to infinity.

It should be straightforward to solve problems having spatial coordinate systems other than Cartesian, e.g., cylindrical, spherical, etc. For the appropriate geometries this would undoubtedly require many less cells to realize a desirable accuracy.

VIBRATING BEAMS

Equation to be Solved

It would seem of particular engineering interest to investigate the usefulness of the difference technique in solving the problem of flexural vibration of beams. Consider the vibrating beam shown in Figure 5. If we limit ourselves to the transverse deflection shown and assume that the flexural planes remain parallel, then for small deflections the equation of motion is given by

$$\rho(x) \frac{\partial^2 y(x,t)}{\partial t^2} + \left[\frac{\partial^2}{\partial x^2} EI(x) \frac{\partial^2 y(x,t)}{\partial x^2} \right] = 0 \quad (30)$$

where

x = horizontal distance from the left end of the beam
 t = time
 $y(x,t)$ = transverse deflection of the beam at any instant
 $\rho(x)$ = mass per unit of beam, at x
 $EI(x)$ = flexural rigidity at x

The bending moment $M(x,t)$ is given by

$$M(x,t) = EI(x) \frac{\partial^2 y(x,t)}{\partial x^2} \quad (31)$$

and the shear is given by

$$V(x,t) = \frac{\partial}{\partial x} M(x,t). \quad (32)$$

Equation 30 is of course subject to both boundary and initial conditions. One type of beam of considerable engineering interest is the cantilever beam (one end built-in, the other free). We will also consider the hinged-hinged beam because it is the easiest to analyze theoretically and will give us a good idea of how the other beams will behave when difference techniques are used.

Derivation of the Difference Equation for the Vibrating Beam

Once again the partial differential Equation 30 for the vibrating beam is converted into a set of ordinary differential equations by using the difference technique. Thus, distance along the beam is broken into N segments of width Δx ; the displacement y_n at the n th station will then be a function of time only. We have from Equation 30 as the equation of motion of the n th cell

$$(\Delta x)^2 \rho_n \frac{d^2 y_n}{dt^2} + M_{n+1} - 2M_n + M_{n-1} = 0 \quad (33)$$

where

$$M_n = \frac{EI_n}{(\Delta x)^2} (y_{i+1} - 2y_i + y_{i-1}). \quad (34)$$

We also note that

$$V_{n-1/2} = \frac{M_n - M_{n-1}}{\Delta x} \quad (35)$$

and

$$\frac{\partial y}{\partial x} \Big|_{n-1/2} = \frac{y_n - y_{n-1}}{\Delta x} \quad (36)$$

Before writing down the complete set of difference equations for N cells, it is necessary to consider the boundary conditions. Assume we have an N cell beam and wish to impose the boundary conditions associated with a particular end fastening, e.g., a free end at the right hand extremity of the beam. This means that both the shear V and bending moment M must vanish at the beam end. Let us assume, then, that the end occurs at $N+1/2$ and that $V_{N+1/2} = 0$. From Equation 35 this implies that $M_N = M_{N+1} = 0$. But from Equation 33 this means that

$$(\Delta x)^2 \rho_N \frac{d^2 y_N}{dt^2} + M_{N-1} = 0$$

$$(\Delta x)^2 \rho_{N-1} \frac{d^2 y_{N-1}}{dt^2} = 2M_{N-1} + M_{N-2} = 0.$$

The remainder of the equations are similar to Equation 33 until the left-hand boundary is reached, at which point the difference equations again depend on the type of end fastening.

Following the same line of reasoning as above, one obtains the following set of conditions for the difference equations for various end fastenings of an N cell beam:

<u>End</u>	<u>Where End Occurs</u>	<u>Condition</u>
Free	$N+1/2$	$M_N = M_{N+1} = 0$
Hinged	N	$M_N = y_N = 0$
Built-in	$N+1/2$	$y_N = y_{N+1} = 0$

The actual way in which these conditions modify the difference equations is best seen by considering a specific type beam, as in the next section.

Computer Circuit for Solving the Cantilever Beam by Difference Techniques

Since it involves both a free end and a built-in end, the cantilever beam shown in Figure 5 seems the best choice for a specific example. The left-hand end of this beam occurs at station $1/2$, while the right-hand end occurs at station $N+1/2$. From Equations 33, 34, and 36 along with boundary conditions the computer circuit shown in Figure 6 is obtained. Initial conditions on y_1 and y_N must of course be specified in an actual problem. Notice that even though the left-hand end of the beam occurs at station $1/2$, the displacement y_1 at station 1 is held fixed at zero.

Theoretical Solution of the Difference Equations for Vibrating Beams

In order to check the accuracy of the difference method for beams, we will now solve for the normal modes of vibration of a cantilever beam by separation of variables. When the space and time variables are separated in the equation for

a cantilever beam and the normal-mode frequencies are determined, the following values are obtained for the dimensionless frequency parameter

$$\beta_n = \omega_n \sqrt{\rho L^4 / EI} \quad .$$

	1	2	3	4	5
β_n	3.516	22.03	61.7	121.0	199.8

If the units are selected so that $\Delta x = 1$, Equation 37 represents the difference equation for y when the cantilever beam is broken into cells.

$$\frac{\rho}{EI} \frac{d^2 y_i}{dt^2} + y_{i+2} - 4y_{i+1} + 6y_i - 4y_{i-1} + y_{i-2} = 0 \quad (37)$$

Let us consider 8 cells and let $\rho/EI = 1$. When the boundary conditions outlined previously are applied (left end built in, right end free) a set of seven simultaneous difference equations result.

As before, we assume y_i varies with time as $\sin \lambda t$. The difference equations are then reduced to 7 simultaneous algebraic equations. Eliminating the y 's gives us

$$1 - 336 \lambda^2 + 3312 \lambda^4 - 5140 \lambda^6 + 2432 \lambda^8 - 456 \lambda^{10} + 36 \lambda^{12} - \lambda^{14} = 0 \quad (38)$$

The roots of the above polynomial in λ^2 are the normal mode frequencies. The first four values of λ_n obtained from Equation 38 are

$$\lambda_1 = 0.0554, \lambda_2 = 0.347, \lambda_3 = 0.940, \lambda_4 = 1.66.$$

For our 8-cell cantilever beam $\Delta x = 1$ and $L = N = 8$. Also, $EI/\rho = 1$ and hence the dimensionless normal-mode frequency β_n is obtained by multiplying λ by 64. In the following table β_n for the 8-cell beam is compared with β_n for the continuous beam.

<u>Mode</u>	<u>Cantilever Beam</u>		
	<u>(continuous beam)</u>	<u>(8 cells)</u>	<u>% deviation</u>
1	3.516	3.545	+ 0.8
2	22.03	22.2	+ 0.8
3	61.7	60.1	- 2.5
4	121.0	111.3	- 8.0

Evidently an 8-cell uniform cantilever beam (actually requiring only 22 operational amplifiers) gives tolerable normal-mode frequencies for the first four modes. For many engineering problems this would be entirely adequate.

In Figure 7 two mode shapes are compared with those for the continuous beam. Agreement seems to be entirely satisfactory.

Computer Solution for an 8-Cell Uniform Cantilever Beam

The 8-cell cantilever beam discussed in the previous section was set up on the electronic differential analyzer using integrator time constants of 0.2 seconds. Normal-mode frequencies were obtained by driving the cells at anti-nodal points with sinusoidal voltages at the normal-mode frequency. The following table compares the computer and theoretical normal-mode frequencies.

Mode	<u>Normal-Mode Frequency</u>		
	<u>Continuous Beam</u>	<u>8-Cell Theoretical</u>	<u>8-Cell Computer</u>
1	0.0437 cps	0.442 cps	0.436 cps
2	0.275	0.276	0.274
3	0.768	0.750	0.747
4	1.507	1.39	1.37

The input resistors used in the circuit for computing differences were calibrated to 0.01 per cent, while the resistors representing flexural rigidity EI and mass per unit length ρ were calibrated to about 0.5 per cent. It was found that a 1 per cent change in one of the input resistors used for taking differences perturbed in the period of the fundamental normal mode by the order of 1 per cent.

Computer Solution for an 8-Cell Non-Uniform Cantilever Beam

An 8-cell non-uniform cantilever beam was simulated on the differential analyzer. This beam had the configuration shown in Figure 8 and represents an aircraft wing with taper ratios of 2:1 in both chord and thickness. Two problems were solved: (1) the tapered beam alone, and (2) the tapered beam with the addition of a concentrated load at station 8. This load simulated a wing tank of half the weight of the wing. A gust load of one-second duration was applied as a force proportional to the chord at each cell. Figure 9 is a sample of the deflection at station 8, and also shows the one second gust load. No structural damping was included in these examples, but it can be accomplished by simply connecting the appropriate resistors across the integrating condensers.

An integrator time constant of 0.2 seconds was used.

The normal-mode frequencies were obtained for the 8-cell beam with and without the wing tank.

These are tabulated along with the values for normal-mode frequencies obtained by a differential analyzer solution of the eigenvalue problem for the case without wing tank.

Mode	<u>Normal-Mode Frequency</u>		
	<u>8-Cell Eigenvalue</u> (No Wing Tank)	<u>8-Cell Difference</u> (No Wing Tank)	<u>8-Cell Difference</u> (With Wing Tank)
1	.0773 cps	.0767 cps	.0372 cps
2	.331 cps	.326 cps	.256 cps
3	.820 cps	.784 cps	.709 cps
4		2.016 cps	2.000 cps 3.279 cps

An interesting structural condition is illustrated in Figure 10, where the moments near the root (station 1) and near mid span (station 4) are recorded for the cases with and without wing tank. For both recordings identical one-second gust loads were applied. The case with wing tank has much lower moments and therefore is not as critical structurally as the case with no wing tank.

Real-Time Simulation of Beam Structures

One of the advantages of electronic differential analyzers over other types of analog computers is the extreme flexibility of their time scales. For example, it is possible with the analyzer to simulate on a one-to-one time scale the aircraft wing discussed in the previous section. If integrator time constants of 0.02 seconds are used, the frequency of the fundamental mode for the 8-cell tapered wing becomes 0.77 cycles per second, which would be the order of magnitude of the frequency for an actual structure.

There is one important effect which must be considered when so speeding up the time scale. Limitations in band width of the dc amplifiers may cause the beam oscillations for the higher modes to exhibit a slight exponential buildup in magnitude. However, the introduction of a small amount of viscous damping (considerably less than actually exists in the structure) easily stabilizes the circuit.

A real-time simulation of structural characteristics could be very useful in testing autopilot designs for some of the larger aircraft and missiles, where structural characteristics must be considered in solving the control problem.

Effect of Small Voltage Transients

The deflection of a beam for a given force is proportional to the fourth power of the length of the beam. Thus as more and more cells are added to the differential-analyzer circuit, the output voltages representing beam deflections becomes more and more sensitive to voltage inputs. The latter may be purposely introduced to simulate forces, or may be inadvertently introduced as a result of power-supply fluctuations or transient voltages when the initial conditions are released. The sensitivity of the network to such disturbances will increase as the fourth power of the number of cells. With electronically regulated power supplies and dc amplifiers which were manually balanced to within 0.01 volt referred to input, no particular difficulty was experienced with the above effect in solving the 8-cell beam problem.

Summary of Difference Technique for Vibrating Beams

The vibrating-beam equation has been solved with the difference method both theoretically and with the electronic differential analyzer. Results show that normal-mode shapes and frequencies exhibit good agreement with continuous beams providing 3 or more cells per half-wave length of the normal mode are used.

Cantilever and hinged-hinged beams have a fixed equilibrium position relative to their surroundings and hence are stable on the electronic differential analyzer. Free-free beams are not supported, however, and will tend to be unstable, since any small voltage unbalance will cause them to rotate and translate as well as vibrate.

Damping can easily be included in the beam equation by placing the appropriate resistors across integrating condensers. Any variable force as a function of time can be introduced at any point or points along the beam. The final computer response gives directly the bending moment and displacement as a function of time and distance along the beam.

This same difference method can be used to solve beams with both torsional and lateral bending.⁴ In this case the torsional equation is similar to the wave equation mentioned earlier. The proper cross-coupling resistors then tie the two systems together.

For a more complete discussion of some of the material in this paper, see Reference 6.

DESCRIPTION OF THE DIFFERENTIAL ANALYZER
TO BE USED AT THE UNIVERSITY OF MICHIGAN FOR SOLVING
PARTIAL DIFFERENTIAL EQUATIONS

An 80-amplifier differential analyzer is being constructed to solve partial differential equations by the difference method. Forty of the dc amplifiers can be used as integrators or summers; the remaining 40 are summers. The inputs and outputs to the amplifiers are brought out to polystyrene patch panels on the front of the relay racks. Input and feedback impedances and the various computer-circuit connections are patched directly into the polystyrene panels. There are 16 amplifiers per relay-rack, with five racks in all.

The dc amplifiers consist of three stages of triode amplification (2-5691 RCA red tubes) and an optional 12SN7 cathode follower for high-power output operation. The amplifiers are flat to about 40kc with a gain of unity. Plug-in drift stabilizing units using Leeds and Northrup Type STD. 3338-1 Converters hold the dc unbalance referred to input to the order of 100 microvolts.

Using the above equipment it will be possible to solve heat, wave, and beam equations in one spatial dimension with up to 20 cells.

BIBLIOGRAPHY

1. Hagelbarger, Howe, and Howe, Investigation of the Utility of an Electronic Analog Computer in Engineering Problems, External Memorandum UMM-28 (April 1, 1949), University of Michigan Engineering Research Institute, AF Con. W33-038-ac-14222 (Project MX-794).
2. Howe, Carl E., Further Application of the Electronic Differential Analyzer to the Oscillation of Beams, External Memorandum UMM-47 (June 1, 1950), University of Michigan Engineering Research Institute, AF Con. W33-038-ac-14222 (Project MX-794).
3. Howe, Howe, and Rauch, Application of the Electronic Differential Analyzer to the Oscillation of Beams, Including Shear and Rotary Inertia, External Memorandum UMM-67 (January 1951), University of Michigan Engineering Research Institute.

4. McCann and MacNeal, Beam-Vibration Analysis with the Electric-Analog Computer, Journal of Applied Mechanics, Vol. 17, No. 1, March 1950.
5. Timoshenko, S. P., Vibration Problems in Engineering, D. Van Nostrand.
6. Haneman and Howe, Solution of Partial Differential Equations by Difference Methods Using the Electronic Differential Analyzer, AIR-1 (October, 1951), University of Michigan Engineering Research Institute.

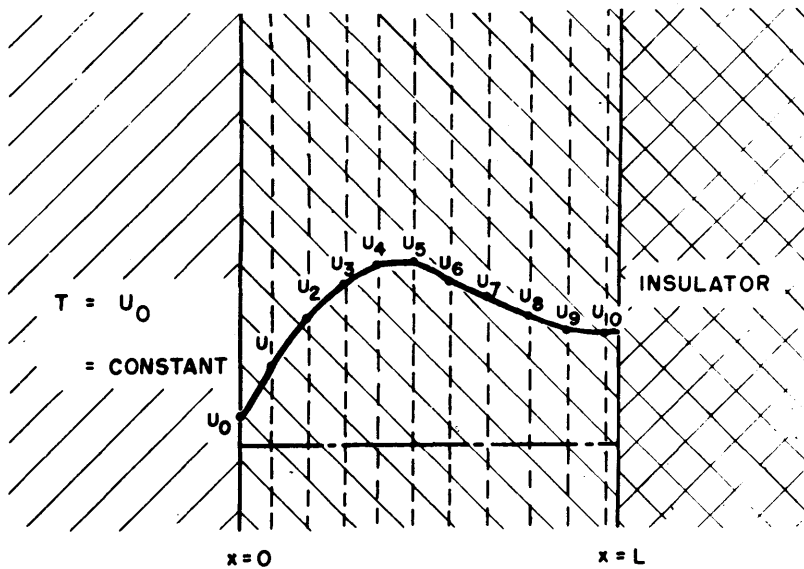

Fig. 1 Station Arrangement for $N = 10$, Heat Equation

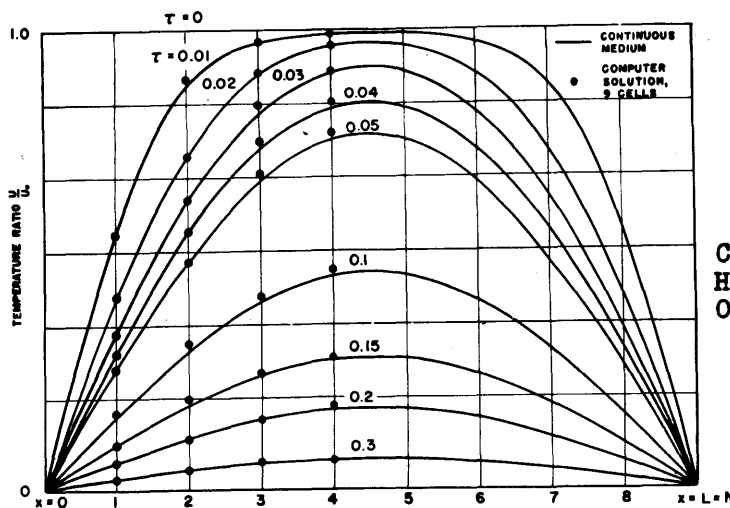

Fig. 3 Temperature Distribution as Function of Time

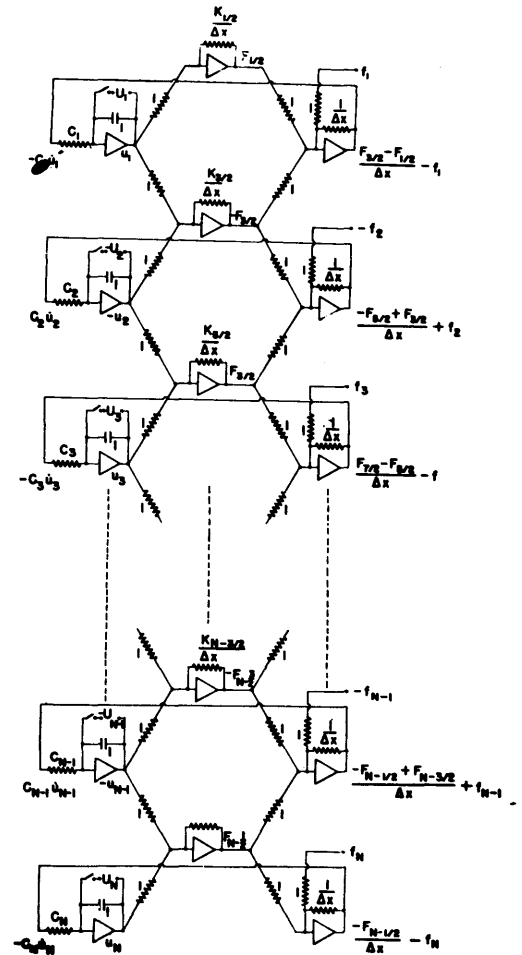

Fig. 2

Computer Circuit for Solving the General Heat Equation with Temperature = 0 at $x = 0$ and Heat Flux = 0 at $x = L = (N+1/2)\Delta x$.

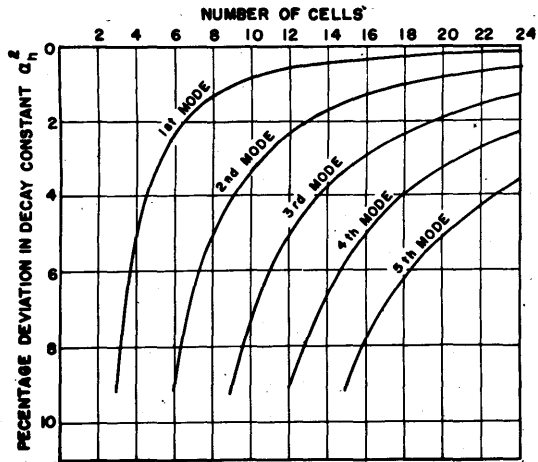

Fig. 4
Percentage Deviation in the Decay Constant as a Function of the Number of Cells.

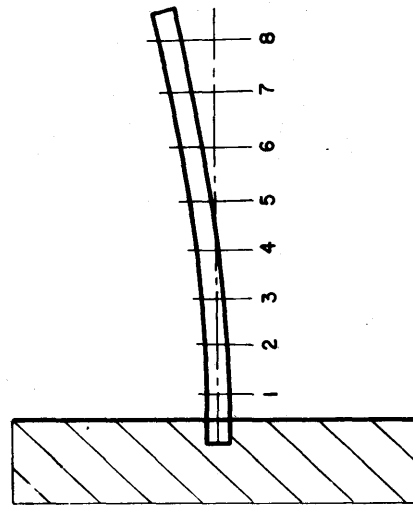

Fig. 5 Vibrating Beam

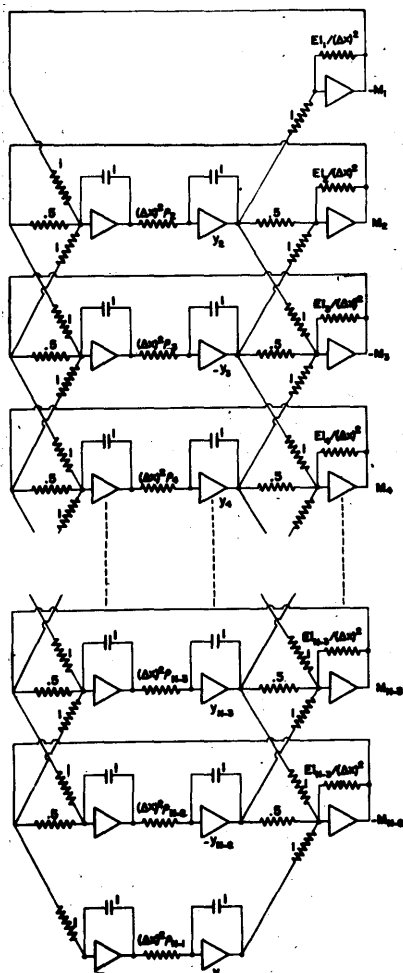

Fig. 6
Computer Circuit for Solving the Cantilever Beam by the Difference Method.

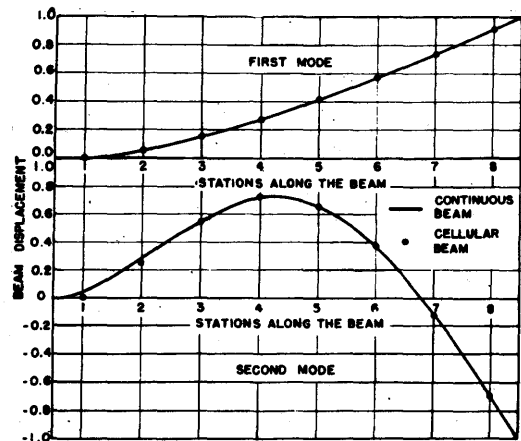

Fig. 7
Comparison of Mode Shapes for 8-Cell Cantilever Beam and Continuous Beam.

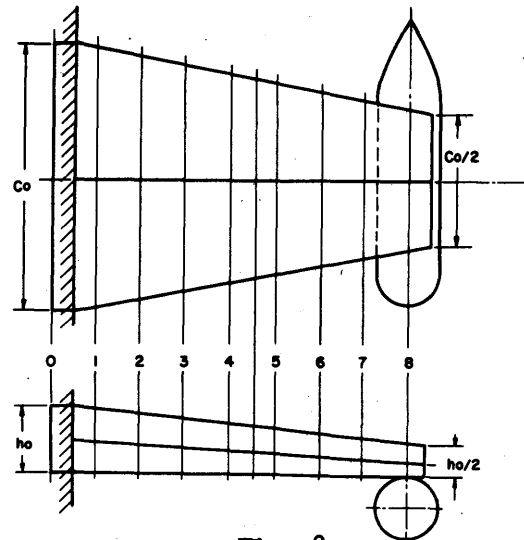

Fig. 8
Non-Uniform Cantilever Beam with Concentrated Load.

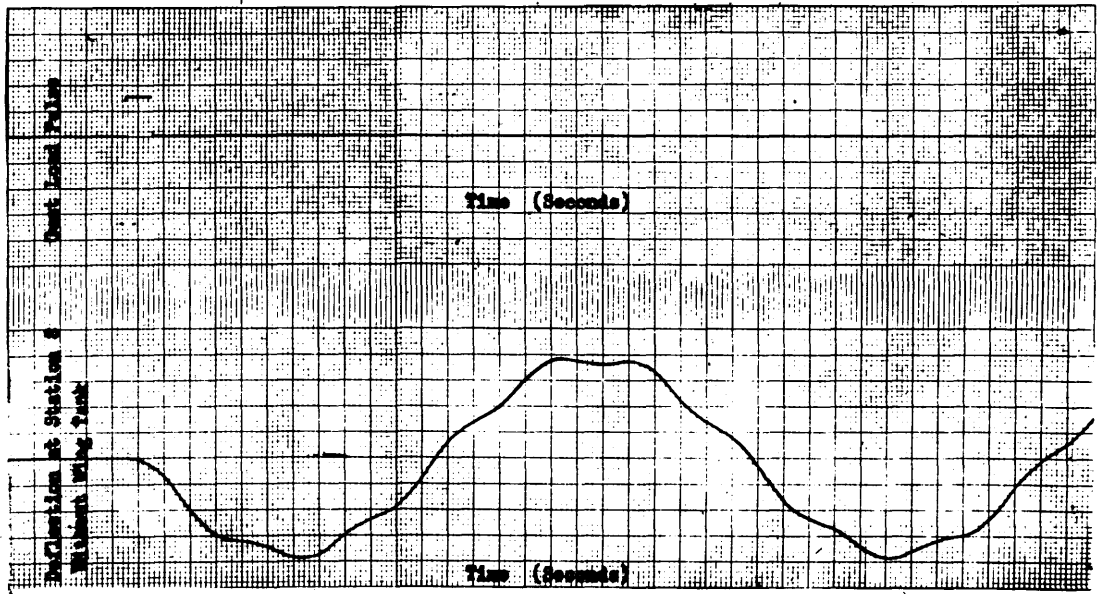

Fig. 9 Sample Solution of 8-Cell Non-Uniform Beam

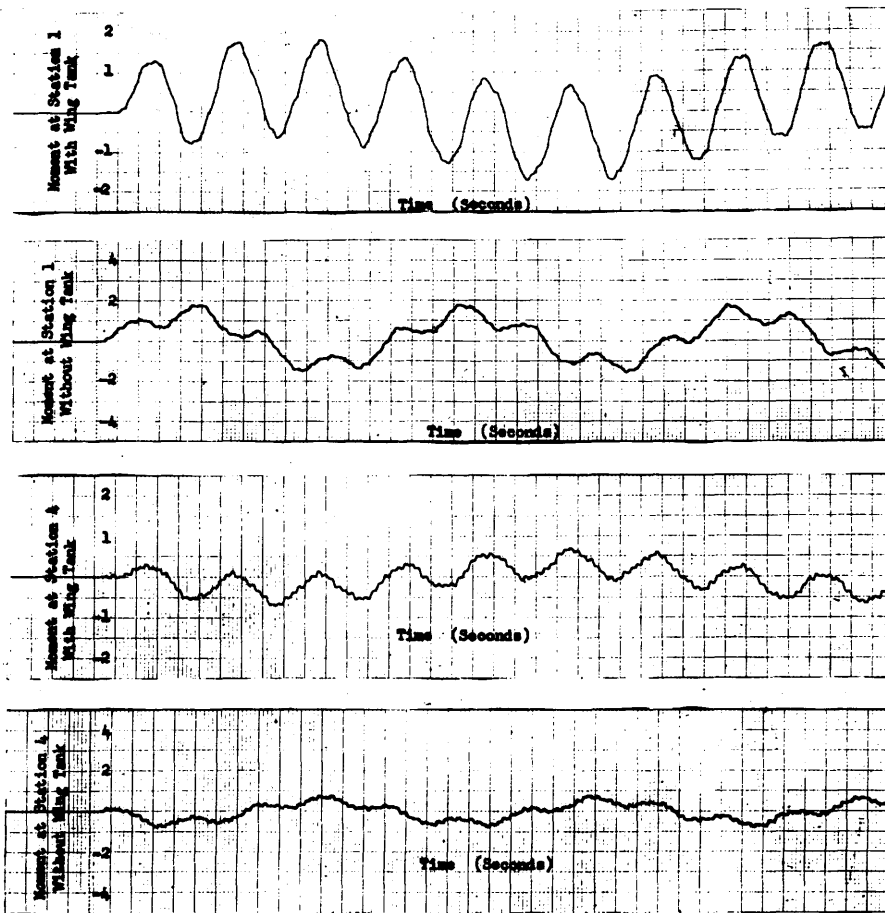

Fig. 10 Comparison of the Moments at Stations One and Four for the Non-Uniform Cantilever Beam with and without the Concentrated Load

THE NORDSIECK COMPUTER

Arnold Nordsieck
University of Illinois
Urbana, Illinois

I Introduction

After some experience with a mechanical differential analyser of the Bush type¹, the author became convinced that there was a need for a smaller, cheaper instrument of this type with a faster and more convenient setup procedure. The large instruments are so large and expensive mainly because of the torque amplifiers they contain and are somewhat inconvenient to use because, aside from considerations of accessibility to the individual researcher, they have rather long and complicated setup procedures.

The need for torque amplification can be eliminated by employing a mechanical integrator which will transmit appreciable torque without slipping at all. The author has developed such an integrator, which will be described in section II. Speed and convenience of setup can best be achieved by arranging to have all interconnections made electrically, and accordingly all the input and output variables of all the units (integrators, multipliers, adders, etc.) in the new instrument are converted into electrical form by synchro motors and generators² and made available at a plug board. The general size can also be kept small without prejudice to accuracy because the key parts can readily be machined to an accuracy of 0.001 inch and because the ultimate output consists of driving revolution counters or pushing pens across graph paper. These processes require negligible forces and torques, so that if care is taken not to dissipate torque needlessly in bearing friction or otherwise, very small motors can be used throughout. The torques employed in the new machine are in the range of one inch-ounce and the total mechanical driving power is less than 1/100 horsepower. The six-integrator machine is about the size of a desk and weighs about 500 lbs. and requires less than 500 watts of 110 volt 60 cycle power. The accuracy cannot be given in any absolute way since it depends on the problem being solved, but it is in the general range of one part in a thousand.

Further reduction in weight and size, for a given number of integrators and with no loss in accuracy, may be possible.

The original machine of this type has been in use at the University of Illinois, Urbana, Illinois for some time and replicas of it have been built and operated at Purdue University, Lafayette, Indiana, and at Radiation Laboratory, University of California, Berkeley, California. A wide variety of problems have been solved on the machines, ranging from stability of non-linear servos and design of non-linear springs to charged particle orbits in linear accelerators and problems in quantum mechanics and nuclear physics.

II Mechanical Integrating Mechanism

From the arguments given in the introduction it follows that an integrating device to make the whole plan technically feasible ought to have three properties: It must work with shaft angles as variables so as to preserve the original inherent accuracy of the Bush machine, which derives from representing a unit of any variable by a large number of shaft revolutions; it must transmit appreciable torque without slipping; and it must fit in design-wise with synchro motors and generators without excessive dissipation of torque in bearing friction, etc.

The device used in the Bush machine¹ has a wheel with a fairly sharp edge, rigidly mounted on a shaft and driven by a smooth, hard flat turntable, and this device will not transmit appreciable torque without slipping. There is another commonly used integrating device, the turntable, ball and cylinder system invented by James Thompson³ which will indeed transmit appreciable torque without slipping provided enough thrust is applied to the ball. The Thompson device requires several bearings in addition to the essential bearings of the input and output shafts, especially if much thrust is applied to the ball. Now the bearings in synchros are high quality anti-friction bearings, and since the synchros were to be an integral part of the design for other reasons, as outlined in the introduction, it seemed desirable entirely to avoid any additional bearings. This was accomplished by developing a kind of cross between the wheel-turntable device of the Bush machine and the cylinder-ball-turntable device of Thompson. In effect we redesign the wheel so that it behaves like a wheel and a ball simultaneously.

The sharp edged wheel rigidly mounted on its shaft cannot transmit appreciable torque without slipping, essentially because as the velocity ratio is varied (it must be varied continuously while the unit is running for integration to be performed) the wheel must slide over the turntable parallel to its own shaft. The ball of the Thompson device can transmit appreciable torque, essentially because it engages in pure rolling motion even when the velocity ratio is continuously varying. Therefore if we alter the wheel by mounting it ball-and-socket wise on its shaft and making its rim part of a spherical surface we have a device of the simplicity of the wheel-turntable device and with the pure rolling property of the Thompson device.

The Figure shows a schematic diagram of the integrating wheel and of its relationship to the smooth hard flat turntable or disc, which is common to all such devices. The wheel is mounted on its shaft by a ball and socket joint which is a lubricated free sliding fit. The ball is rigidly fixed to the shaft. A pin projecting radially from the ball slides between a pair of pins mounted axially in the wheel, thus keying the wheel to the shaft. Hence the wheel is free to turn, relative to the shaft, about any axis

normal to the shaft within limits set by a stop. On the other hand rotation of the wheel about the shaft axis is positively communicated to the shaft. The whole attachment of the wheel to its shaft is equivalent to what is normally called a universal joint of limited misalignment.

The rim of the wheel is part of a spherical surface with center coinciding with the center of the ball. This surface must be accurate and hard.

Several springs are fastened to the wheel shaft and bear on the wheel near its rim in such a way as to tend to straighten the wheel up. The tension in these springs is adjusted so that in operation they are able to rotate the wheel about an axis through the point of contact and the center of the ball but are not strong enough to slide the wheel on the turntable.

The value of the "integrand" in the operation of integration is represented by the distance from the axis of the turntable to the point of contact, labelled "d" in the Figure. If we imagine that the turntable axis is fixed and that the wheel shaft is moved any given distance parallel to itself, then because of the spherical form of the wheel rim the point of contact will move an exactly equal distance; consequently "d" will change by the same distance. In practice we move the turntable and hold the wheel shaft longitudinally fixed, but the net effect is the same. If enough normal thrust is applied to the point of contact through the shaft bearings the wheel will engage in pure rolling motion so long as it clears the stop. In actual operation the distance "d" varies and the wheel shaft rotates simultaneously, and the change in "d" per quarter revolution of the wheel shaft is small compared to the radius of the wheel. Therefore the tilt or nutation of the wheel introduced by the variation of "d" is continuously carried around and wiped out by the action of the springs. Consequently in operation the wheel departs from its square position by barely visible amounts and rarely comes near the stop. An exception to this normal condition occurs when "d" is near zero since then the rate of rotation of the wheel shaft is very small and the tilt of the wheel may accumulate considerably before it is carried round and nullified by the springs. The width of the wheel rim and the clearance of the stop have been so chosen that the wheel is rarely brought up against the stop even when traversing through the position "d" = 0. Occasional contact with the stop and corresponding momentary slippage at the point of contact are not serious because the error thus introduced is proportional to the fraction of the time that slipping occurs.

When this integrating wheel is to be used to drive a synchro generator (the "integral synchro" of the integrator) the diameter of the wheel is chosen slightly larger than the diameter of the

body of the synchro and the wheel is mounted directly on the synchro shaft close up to the front bearing. No additional bearings over and above the synchro bearings are employed.

III General Description of Computer

Generally speaking the computer consists of a collection of independent units mounted together on a rolling table, most of these units being supplied in multiple, for mechanically performing the elementary operations which in combination enable one to solve a system of ordinary differential equations. These units are integrators, multipliers for multiplying any variable by a chosen constant, adders, plotting tables for reading functional relationships graphically into or out of the computer, a motor-driven independent variable unit for turning the independent variable shafts, hand cranks for turning any shaft by hand as in manual curve following, and revolution counters for indicating the numerical value of any chosen variable. At present we put on one rolling table six integrators, six multipliers, four adders, two plotting tables, one independent variable unit, two or three hand cranks and two revolution counters. The two last mentioned counters are in addition to the revolution counters fitted to the integrand synchro shafts on the integrators. A six integrator unit can be used alone for relatively small problems or several of them can be combined into a computer of larger capacity. As indicated earlier, all the input and output variables of all these units are brought to a master plug board in electrical synchro form. The operation of setting up or clearing out a problem involves only plugging up or clearing out a set of connections on the plug board and manually selecting the gear ratios on the multipliers.

The integrators have an integrator factor of $1/60$, i.e. if the integrand is set at one shaft revolution the velocity ratio is $1/60$. The range of the integrand is from minus 60 to plus 60 turns (with some leeway), significant to $1/20$ turn.

The multipliers make gear ratios of 0.1, 0.2, . . . 0.9 available by manual selection.

An adder consists of a differential synchro driving an ordinary synchro.

The plotting tables have lead screws of 20 threads per inch and are designed for use with standard $1/20$ inch graph paper, 7 inch by 10 inch grid on $8\frac{1}{2}$ inch by 11 inch paper. Each table may be used for either input or output as desired.

The computer is provided with several types of protective circuits which make it essentially fool proof in the sense that the operator can spoil a problem solution but cannot damage the

computer by incorrect connections or operation. Each synchro is provided with a protective ballast lamp and condenser combination which warns the operator and reduces the energizing voltage to prevent burnout if that machine is desynchronized. For each lead-screw driven element a warning light is provided to indicate when it is near the mechanical limits of its travel and the drive is completely disconnected before these limits are reached. The integrating wheels are kept disengaged except when a problem solution is actually being run in order to permit synchronizing the synchros and setting initial values of integrands without sliding of the wheels on the turntables.

References

1. V. Bush, "The Differential Analyser, a New Machine for Solving Differential Equations," Journal Franklin Institute vol 212, p 447, 1931.
 V. Bush and S.H. Caldwell, "A New Type of Differential Analyser," Journal Franklin Institute vol 240, No. 4, 1945.
 J. Crank, "The Differential Analyser," Longmans Green and Co., London, 1947.
 A.C. Cook and F.J. Maginniss, "Applications of the Differential Analyser," General Electric Review vol 52, p 14, 1949.
2. L.F. Holder, "Principles of Selsyn Equipments and Their Operation," General Electric Review vol 33, p 500, 1930.
 H.W. Reding, "Synchronized Drives without Mechanical Connection," Electric Journal vol 33, p 277, 1933
3. James Thompson, Proceedings of the Royal Society, vol 24, p 262, 1876.

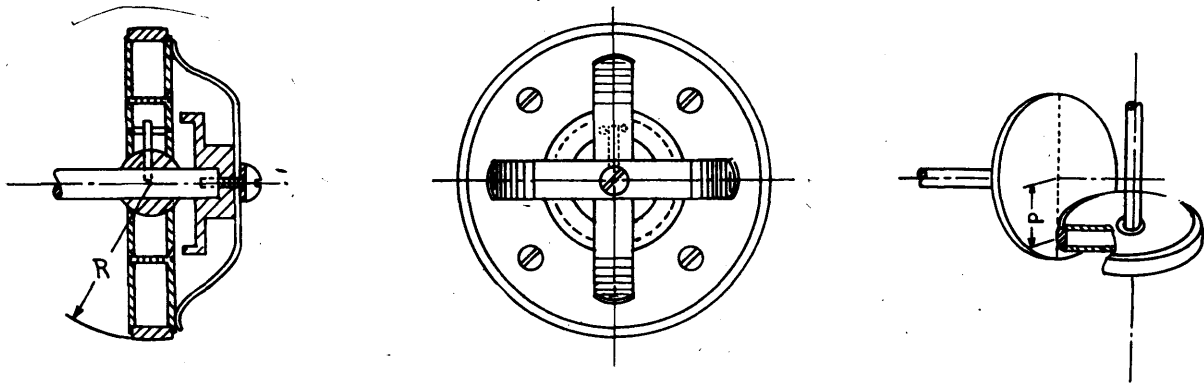

Fig. 1 - Schematic Diagram of Integrating Wheel.