

# **ARIX SYSTEMS CORPORATION**

**Site Preparation Manual  
for the  
Models 800 and 825**

**Part Number MA-99243-00  
Revision A**

**Copyright 1989  
Arix Systems Corporation, Inc.  
821 Fox Lane  
San Jose, CA 95131**

**FCC WARNING:**

**This equipment generates, uses, and can radiate RF (radio frequency) energy, and if not installed and used in accordance with the information provided by ARIX, may cause interference to radio communications. It has been tested and found to comply with the limits for Class A computing devices pursuant to Subpart J of Part 15 of FCC rules, which are designed to provide reasonable protection against such interference when operated in a commercial environment. Operation of this equipment in a residential area is likely to cause interference, in which case the user, at his own expense, will be required to take whatever measures may be required to correct the interference.**

March 1989

Copyright © 1989, ARIX Systems Corporation.

This document contains the latest information available at the time of preparation. Therefore, it may contain descriptions of functions not implemented at manual distribution time. To ensure that you have the latest information regarding levels of implementation and functional availability, please consult the appropriate release documentation or contact your local GTE Spacenet Representative.

ARIX reserves the right to modify or revise the content of this document. No contractual obligation by ARIX regarding level, scope, or timing of functional implementation is either expressed or implied in this document. It is further understood that in consideration of the receipt or purchaser of this document, the recipient or purchaser agrees not to reproduce or copy it by any means whatsoever, not to permit such action by others, for any purpose without prior written permission from ARIX.

ARIX is a trademark of ARIX Systems Corporation.

UNIX is a registered trademark of AT&T.

## Preface

This guide provides information and recommendations to help prepare for the installation of the ARIX Model 800/825 system. It describes physical and functional characteristics of the host processors and includes information on planning the attachment of terminals, printers, modems, and other devices to be configured with the system.

All recommendations of this site preparation guide should be followed before the system is installed. Planning is important because, once the system is installed, it can be very difficult to make changes or to correct problems.

This guide is to be used in conjunction with the *ARIX Installation and Maintenance Manual for the Models 800 and 825*.

# Table of Contents

Section 1	Introduction . . . . .	1-1
	CUSTOMER RESPONSIBILITIES . . . . .	1-1
	TECHNICAL ASSISTANCE . . . . .	1-2
Section 2	System Planning . . . . .	2-1
	SYSTEM COMPONENTS . . . . .	2-1
	SITE PLANNING CONSIDERATIONS . . . . .	2-4
Section 3	Site Environmental Planning . . . . .	3-1
	TEMPERATURE/HUMIDITY . . . . .	3-2
	MEDIA STORAGE . . . . .	3-3
	HEAT/SOUND OUTPUT . . . . .	3-4
	ELECTROMAGNETIC INTERFERENCE . . . . .	3-4
	ELECTROSTATIC DISCHARGE . . . . .	3-5
Section 4	Power Considerations . . . . .	4-1
	VOLTAGE/FREQUENCY COMBINATIONS . . . . .	4-2
	VOLTAGE/FREQUENCY VARIATIONS . . . . .	4-2
	Voltage Variations . . . . .	4-2
	Frequency Variations . . . . .	4-3
	BRANCH CIRCUIT CONSIDERATIONS . . . . .	4-3
	POWER RECEPTACLES . . . . .	4-4
Section 5	Site Physical Planning . . . . .	5-1
	PHYSICAL CHARACTERISTICS . . . . .	5-1
	SPACE REQUIREMENTS . . . . .	5-2
	FLOOR LOADING . . . . .	5-2
Section 6	Cabling Considerations . . . . .	6-1
	CABLE LENGTH . . . . .	6-1
	CABLE ROUTING . . . . .	6-1
	CABLE CONNECTORS . . . . .	6-2

# Table of Contents

---

	NOISE ENVIRONMENT . . . . .	6-2
	CABLE TYPE . . . . .	6-2
	EXISTING ON-SITE CABLES . . . . .	6-2
	ARIX SYSTEM CABLES . . . . .	6-3
Section 7	Planning and Preparation Checklist . . . . .	7-1
 Figures		
Figure 4-1.	Power Plug Diagram . . . . .	4-4
 Tables		
Table 3-1.	Environmental Operating Limits . . . . .	3-2
Table 3-2.	Storage and Shipping Environmental Limits . . . . .	3-3
Table 3-3.	Magnetic Media Storage Limitations . . . . .	3-3
Table 3-4.	Heat and Sound Output . . . . .	3-4
Table 4-1.	Power Requirements . . . . .	4-1
Table 4-2.	Voltage/Frequency Options . . . . .	4-2
Table 4-3.	Voltage Variations . . . . .	4-2
Table 4-4.	Frequency Variations . . . . .	4-3
Table 5-1.	Physical Characteristics . . . . .	5-1

## Section 1

# Introduction

This guide contains wiring, space, and environmental information to help the user prepare for the installation of an ARIX Models 800 or 825 system.

From this point on throughout this document, the Models 800 and 825 will be referred to as the Model 800/825.

The ARIX systems and the related peripherals are designed to be installed by the customer/user. If the installation site has any of the following unusual characteristics, contact an ARIX Customer Support Representative before beginning the installation.

- High or low humidity
- Large temperature variations
- Corrosive chemicals
- Contaminated atmosphere, especially conductive particles
- Vibration
- High-altitude

## CUSTOMER RESPONSIBILITIES

The customer has sole responsibility for meeting the electrical, environmental, and safety requirements of the system, and for operating in conformance with appropriate ordinances and building codes. A summary of customer responsibilities follows.

- Provide and install all communications cables, wall jacks, special connectors, and associated hardware.
- Provide and install all necessary power outlets, distribution boxes, conduits, grounds, lightning arresters, and associated hardware.
- Make sure any building alterations are in accordance with local electrical and building codes, as well as meet environmental requirements of the system.
- Provide floor coverings and environmental systems that prevent the buildup and discharge of static electricity. If humidity is below that recommended in this guide, contact ARIX Customer Support for assistance.

- Provide enough space for field service access to the system. Suggested clearance in front and in back should be 45 inches (114.3 cm). No clearance is required for either side.
- Provide appropriate safety measures, such as fire extinguishers and properly-sized circuit breakers. Do not use sprinkler systems for fire protection.
- When equipment arrives, unpack and inspect the equipment for damaged or missing items. While unpacking the system, if damage is evident or the shipment is not complete, do not proceed. Contact the shipper immediately and notify ARIX.
- Install the ARIX system and peripherals, and make the necessary cable connections to communications equipment. Notify ARIX Customer Support immediately if there are any problems.
- Provide other equipment as required (for example, modems) and arrange for installation by the responsible vendor.
- Verify correct operation in accordance with instructions in the Installation and Maintenance Guide provided with the equipment.
- If an equipment failure occurs, use the checkout procedures in the *Installation and Maintenance Manual* to isolate and correct all possible malfunctions. If the system does not power up or a failure is indicated during the power-on confidence test, notify ARIX Customer Support.
- Notify an ARIX Customer Support Representative if equipment needs to be relocated or returned. Follow the instructions provided for repacking and relocation. Do not return equipment or components without an RMA (return materials authorization) from ARIX.

To avoid invalidating the warranty coverage or damaging the system beyond repair, contact ARIX Customer Support before installing or operating the system in a potentially hazardous or hostile environment.

## TECHNICAL ASSISTANCE

Warranty and Support Agreement assistance for this product is available from ARIX Customer Support. All calls for support should be made directly to our support department:

- **800-237-2783** from outside California,
- **800-521-5783** from inside California, outside the 408 area code, or
- **408-432-1200** and ask for Customer Support.

## Section 2

# System Planning

The first step in planning the installation of the ARIX Model 800/825 is to become familiar with the terminals, printers, modems, and other equipment used in the system. In most cases, manuals for the devices are the best source of information. Understanding this equipment, especially its requirements and capabilities, will contribute to successful and efficient site planning. The next step is to identify the location for the system and to determine the requirements. This will ensure a quicker, easier installation.

It is especially important to determine data interconnect cabling requirements in advance to avoid installation delays. For example, some peripherals are supplied with interconnect cables and some are not. In some cases, standard-length cables may not be the correct length or may be supplied with the wrong gender or type of connector. In addition, verify that signal pin definitions for peripherals and conductors used in the cables are compatible with those specified for the ARIX system (see *Section 5* in the *Installation and Maintenance Manual for the ARIX Models 800 and 825*).

Make sure that the peripherals are supplied with the correct interface. Certain peripherals, notably printers, may not include an interface in the base price. In addition, the installation may require components such as line buffers or serial/parallel converters for best operation.

## SYSTEM COMPONENTS

A basic ARIX system consists of the main cabinet, containing the CPU. The number and type of components, including terminals, printers, and system-related furniture is dependent on the needs of the user. The following is a summary of the various ARIX system modules:

### *CPU32*

The CPU32 provides 32-bit processing capabilities using a 12.5 Mhz 68020 microprocessor, an 8 kilobyte cache memory, full memory management and protection, and 128 kilobytes of PROM. The system architecture allows a maximum of 2 of these boards to be running simultaneously in a single 800/825 system. These cards can only be installed into a system card slot intended for CPU or memory cards.



### *CPU32/25Mhz*

The CPU32/25Mhz has 32-bit processing capabilities using a 25 Mhz 68020 microprocessor, a 64 kilobyte cache memory, full memory management and protection, 8K bytes of static RAM, and two 512 kilobyte EPROMS. The system architecture allows a maximum of 2 of these boards to be running simultaneously in a single 800/825 system. These cards can only be installed into a system card slot intended for CPU or memory cards.

### *DMA MEMORY CONTROLLER*

The Direct Memory Access (DMA) Controller provides all memory timing, refresh signals, access control (2 channels - DMC4/2), and error correction logic for the entire system. Each system requires one (and only one) of these boards.

### *MEMORY*

There are two types of memory boards. The memory boards contain either 4, 8, 16, or 32 MB of error-correcting random access memory (RAM), using either 256K or 1MB memory chips (depending on the board capabilities).

One type (older) uses the high density 256K dynamic RAM chips and can support either 4 or 8 MB of main memory. A system can have a maximum of 16 MB of main memory (two 8 MB boards) using this board. The other type (newer) uses the high density 1MB dynamic RAM chips and can support either 8, 16, or 32 MB of main memory. Using this board, a system can have a maximum of 64 MB of main memory (two 32 MB boards). A system containing the memory board populated with 1MB chips **must** also contain the 25 Mhz Application Processor (CPU32/25) board.

The memory board is arranged in 39-bit memory locations, where 32-bits are the actual data and 7-bits are used to store the error correction information. The Model 800/825 can support up to 2 memory boards. The memory boards can only be used in slots which are reserved for either CPU or MEMORY.

### *SYNC/ASYNC SERIAL I/O*

The serial I/O board is an intelligent controller card capable of supporting up to 8 serial data I/O channels. A maximum of 2 serial channels can be synchronous, and the remaining serial channels are asynchronous. The 2 synchronous and 6 asynchronous channels can be used at the same time. Each channel can operate at a different baud rate ranging from 150 to 38.4K baud. This type of board has one 8 bit parallel port for a Centronics-type interface. A serial I/O board may only be placed into an Input Output Control Processor (IOCP) slot in the backplane, and requires an appropriate interface card.

***DISK TAPE CONTROLLER - HSDT and EDT***

The disk tape controllers support two SMD disk drives and a 9-track, 1/2-inch magnetic tape, or four SMD disk drives and a 1/4-inch cartridge tape. The HSDT transfer rate is 1.8 megabytes per second. The EDT transfer rate of 2.4 megabytes per second supports faster disk drives. Disk tape controllers require an appropriate 9-track or cartridge interface card.

***5 1/4 INCH SMD DISK DRIVE***

The 800/825 accommodates up to three internal 5¼ inch SMD disk drives, each providing 172 MB of unformatted capacity.

***QUARTER-INCH STREAMING TAPE***

The Quarter-Inch Streaming Tape Drive is a 5¼ inch form-factor drive with a 45 MB or 60 MB (with a 600 ft. tape) formatted capacity.

***POWER SUPPLY***

The power supply provides +5 V dc, +12 V dc, and -12 V dc to the system.

***BATTERY BACKUP***

An optional accessory, the battery backup provides a measure of protection in the event of local power "brown outs" or short term power failures. It is capable of powering the entire system for up to 10 minutes and includes a built-in battery charger.

***TERMINALS***

Synchronous terminal connections require DB-25 pin connectors to the RS232C interface. Synchronous terminal ports can be used as asynchronous ports. Dedicated asynchronous ports on the 800/825 typically require DB-25 pin connectors on the terminal end and a direct RJ12/RJ11 connection to the serial port.

***PRINTERS***

A printer can be attached to the ARIX system through the RS-232C serial interface, or a Centronics-compatible parallel interface. Line buffers or serial/parallel converters may be required for best operation. The parallel printer port requires a DB37 connector at the end that connects to the system.

### MODEMS

A modem device can be attached to the ARIX system through the RS-232C serial interface only. Signal definition and pin usage may vary depending on the modem type. It is important that the cable between the modem device and the ARIX system be properly configured. In addition, the modem may require that various options or switches be set. Note that for modem operation, the output driver chips on the GC/IOCP can be switched. For detailed instructions, refer to the *ARIX Installation and Maintenance Manual*. The manual provided with the modem can also be referenced for more specific information.

## SITE PLANNING CONSIDERATIONS

The ARIX system is designed to operate in a wide range of environmental conditions. Normally, little or no modification is required to existing office facilities to install and operate this equipment successfully. Nevertheless, in planning the installation, there are several important factors to consider:

- General environmental considerations, such as temperature and humidity (Section 3)
- Power requirements (Section 4)
- Space for and placement of the equipment (Section 5)
- Cabling (Section 6)

A few additional factors to consider follow:

- Cable Routing

It may be necessary to route signal cables through walls, ceilings, or false floors, especially if a number of peripherals at various places throughout the facility are to be installed. Installation of the system may be accomplished more readily if signal cables are installed first. These cables can be ordered separately and can be shipped in advance of the equipment.

Cable raceways or similar materials to protect loose cables that interconnect the equipment may be required. It is recommended that cable raceways or other materials are procured before the equipment arrives so they can be installed at the same time as the cables. ARIX supports a 50 ft. RS-232C cable for each connection to the system.

- Storage Facilities

When planning the installation, consider the possible need for additional storage facilities that may be required for reusable shipping containers, paper, ribbon, and printwheels. It is recommended that necessary supplies are on hand and ready for use when the equipment arrives.

Before planning for installation of the ARIX system, read the publications describing the system and any related user publications that describe the peripherals. To obtain copies of these publications, or if there are any questions concerning installation planning, contact an ARIX Customer Support Representative.

## Section 3

# Site Environmental Planning

The ARIX system is designed to operate in the typical range of environmental conditions found in many commercial office buildings. However, avoid installing this equipment in areas where adverse environmental conditions may exist.

### **DO NOT INSTALL THE SYSTEM IN THE FOLLOWING:**

- Areas subject to extreme temperature or humidity variation.
- Kitchens, air-conditioner exhaust areas, or similar areas conducive to exceptional humidity.
- Line power networks that are subject to large voltage excursions. Typical examples of what not to have in the network are air conditioning systems, refrigeration units, or any type of highly inductive load that is cycled on and off periodically.
- Workshops or manufacturing environments producing high levels of airborne particles, such as dust, grit, smoke, or corrosive chemical agents.
- Basements or similar areas susceptible to flooding.
- Areas subject to electromagnetic fields or radio-frequency radiation.
- Areas subject to mechanical vibration or intermittent, high-g force excursions.

## TEMPERATURE/HUMIDITY

The ARIX system operates in a wide environmental range. It is designed to operate in the typical office environment under the same conditions as the people who use it. It is not recommended that the system be operated continuously at or near its temperature or humidity limits, or in a location where it is likely that these limits may be exceeded.

Certain combinations of temperature, humidity, and atmospheric pressure result in moisture condensing on surfaces in the system. This so-called "triple point" is typically well outside the range of conditions where the ARIX system is located, but if there is any doubt, wet-bulb thermometer readings should be taken and an operating curve plotted.

**CAUTION**

**It is particularly important to avoid operating the system in environmental conditions that may cause condensation. Even a small amount of moisture may result in a catastrophic system failure.**

The nominal operating temperature range is 21° to 27° centigrade (70° to 80° Fahrenheit), with a relative humidity range of 40 to 60 percent. When operating the equipment within this range, the operating safety margin effectively permits an extended operating period in case of heating or air conditioning systems failure. Tables 3-1 and 3-2 specify the environmental limits of the System.

**Table 3-1. Environmental Operating Limits**

OPERATING TEMP RANGE	RELATIVE HUMIDITY	ALTITUDE
5°C - 40°C (40°F - 102°F)	20% - 80% (noncondensing)	4000 ft.

The operating limits can be extended to higher altitudes by derating the operating temperature limit.

The nonoperating conditions (storage/shipping) of the system are:

**Table 3-2. Storage and Shipping Environmental Limits**

NONOPERATING TEMP RANGE	TEMP CHANGE	RELATIVE HUMIDITY	HUMIDITY CHANGE	ALTITUDE RANGE
-30°C to 60°C (-22°F to 140°F)	10°C per hour (non- condensing)	5% to 95%	10% per hour (non- condensing)	Sea Level to 40,000 ft.

## MEDIA STORAGE

Store all media (backup tapes) under the environmental conditions recommended below. If these storage conditions are not possible, place the tapes in the same room as the system for at least one hour before using them to allow the tapes enough time to adjust to the temperature.

**Table 3-3. Magnetic Media Storage Limitations**

MEDIA TYPE	STORAGE TEMPERATURE	STORAGE HUMIDITY
Tape Cartridge	5°C - 45°C (41°F - 113°F)	20% - 80% (noncondensing)

## HEAT/SOUND OUTPUT

Table 3-4 shows the heat and sound output from each unit in the system.

**Table 3-4.** Heat and Sound Output

UNIT	SOUND OUTPUT	HEAT OUTPUT
ARIX 800/825 CPU	55 dBA	3300 BTU/HR.
9-Track (Cipher) Tape Drive	—	1160 BTU/HR.

## ELECTROMAGNETIC INTERFERENCE

As is true with most electronic equipment, electromagnetic fields or radiation emanating from radio, television, or radar antennas, may interfere with the ARIX system or its associated equipment.

Operating problems may also result from electromagnetic fields from industrial equipment such as arc welders, insulation testers, medical equipment, large high-voltage transformers, or similar equipment. Three-phase power distribution lines and related distribution panels, electric heating units, electric motors, and generators also may cause electromagnetic interference with the equipment.

To prevent such interference from causing problems, keep the equipment as far away from the sources of interference as possible. If this is not feasible, at least be aware of the potential problems.

Shielding may minimize interference if the shielding is properly located and grounded. In some cases, a separate ground circuit for the system may reduce interference.



## **ELECTROSTATIC DISCHARGE**

High electrostatic charges can build up as a result of people, equipment, or furniture in contact with carpeting or other types of floor covering. When these static charges are discharged into the metal of the equipment, desk, or table on which the equipment is located, interference with proper operation of the equipment may result.

Careful choice of furniture and use of coverings with antistatic properties should minimize static problems, as will the use of commercially available antistatic sprays on furniture and wall coverings. Electrostatic discharge is often a result of very low humidity, outside the recommended range of system operation.

If the system must be operated under conditions of very low humidity on a temporary basis, consider the following precautions:

- Wear only cotton clothing - no nylon or synthetic fabrics.
- Place conductive mats in front of the system and under each peripheral. Connect the mats to system ground.
- Before inserting a cartridge tape, touch the metal on the cartridge, and at the same time, something that is at system ground.
- Use anti-static spray as directed on the container.

Anyone in close proximity to a system should be properly grounded with a wrist strap or foot strap.

## Section 4

### Power Considerations

Specifying the primary input power voltage (115 or 230 VAC nominal) and frequency (50 or 60 Hz) is part of the ordering process for the ARIX system. The system is then manufactured and tested to meet power requirements prior to shipment. ARIX recommends that circuits be used to provide primary power for this equipment in accordance with the following:

- 60 Hz, 15A, single pole, 115 or 230 VAC ( $\pm 10\%$ ), single phase, 2-wire and ground
- 50 Hz, 15A, single pole, 115 or 230 VAC ( $\pm 10\%$ ), single phase, 2-wire and ground

Primary input power requirements for this equipment appear in Table 4-1:

**Table 4-1. Power Requirements**

UNIT	PRIMARY INPUT POWER
ARIX 800/825 (Fully configured)	1.2 KVA
Typical Dot Matrix Serial Printer	0.10 KVA
Typical Correspondence Quality Printer	0.22 KVA
Typical Laser Printer	1.5 KVA
Typical Personal Computer	0.50 KVA
Typical Video Terminal	0.40 KVA

## VOLTAGE/FREQUENCY COMBINATIONS

The ARIX 800/825 system is available to match voltage and frequency requirements for virtually any combination to be found worldwide. The following table shows the availability of various voltage and frequency options:

**Table 4-2.** Voltage/Frequency Options

Voltage	Frequency
115 VAC ( $\pm 10\%$ )	50/60 Hz
230 VAC ( $\pm 10\%$ )	50/60 Hz

## VOLTAGE/FREQUENCY VARIATIONS

The ARIX systems are designed to operate effectively despite significant variations that may occur in input voltage and frequency. Permissible variations are defined in the table that follows. If there are any concerns about voltage or frequency variations that may be experienced within the power network, contact the power company.

### Voltage Variations

All component parts of the ARIX systems have been designed to function within the same limits of voltage variation, specifically. The ranges are shown in Table 4-3.

**Table 4-3.** Voltage Variations

Nominal Voltage	Voltage Limits
115 VAC	92 to 132 VAC
230 VAC	187 to 264 VAC

## Frequency Variations

All component parts of the ARIX system are tolerant of frequency variations within the limits specified in the following table:

**Table 4-4. Frequency Variations**

Nominal Frequency	Tolerance
47-63 Hz	$\pm 2$ Hz

## BRANCH CIRCUIT CONSIDERATIONS

Random or transient electrical noise in the power circuit can cause errors in data transmission. It is highly recommended that the specified power be provided from a branch circuit dedicated to the electronic equipment at site. Small equipment, such as terminals, modems, or printers may be powered from the same branch circuit. Large, high-current equipment, such as the main computer, expansion cabinet, and the laser printer, should have a separate, dedicated branch circuit.

To avoid introducing electrical noise into the system, other equipment (especially refrigerators, air conditioners, or heavy-current inductive motors) having an intermittent duty cycle should not be connected into the same branch circuit used for computer-related equipment. It is also recommended that the branch circuit being used either be equipped with a separate fuse or with an appropriate circuit breaker. This circuit should also be properly grounded. In some environments, a separate ground circuit may be required to eliminate "ground loops".

If the power network is less than optimum, consider using an isolation transformer or battery-backup system. There are a number of manufacturers providing various levels of protection. It is highly recommended that a power line monitor be used for some period of time before installing the system. The monitor can help select the best branch circuit available, and/or determine how much protection is required for the circuit.

## POWER RECEPTACLES

As part of the site planning, it is important to ensure that power receptacles will accommodate the equipment and are close to the equipment. An appropriate power cable is supplied with most systems, as specified in the order.

The power cables supplied with the ARIX 800/825 series systems are polarized, 3-wire cables with a standard male connector for 60 Hz units. The 3-prong plugs are standard NEMA 5-15P and are for use in 3-wire circuits where one wire is ground. If the power cable on the equipment does not have a plug installed at the factory, make certain that during the installation the green/yellow wire in the power cable is connected to ground in the power circuit.

Refer to the Figure 4-1 to ensure that the receptacles are compatible with the plugs to be used with the equipment. If there are any questions concerning selection of the correct receptacles, contact an ARIX Customer Support Representative.

As in the United States, Canada, Japan, and Korea use a type A plug for 125 V power (see Figure 4-1). Other countries use 250 V. Most other countries use a type B plug. For some countries, plugs must be added by the customer.

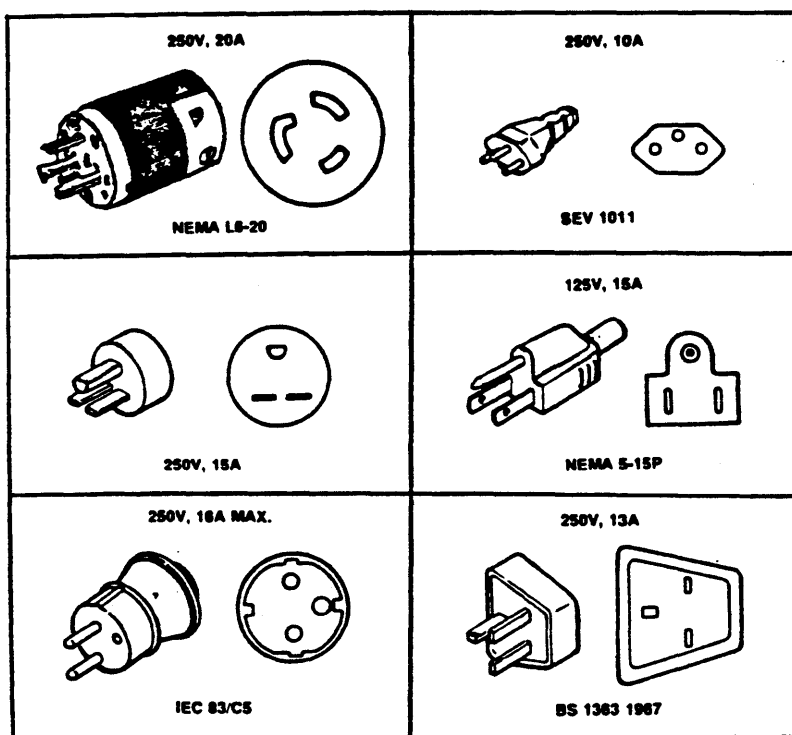

Figure 4-1. Power Plug Diagram

## Section 5

### Site Physical Planning

In addition to site environmental planning, physical requirements for the units in the installation facilities must also be considered:

- Weight of each unit
- Operator Access Space
- Service Access Space
- Air Circulation for operation within its environmental limits
- Entry and exit points for the interconnecting cables
- Maximum cable lengths.

It is recommended that a site map showing the Main Cabinet and all peripheral locations be prepared. The drawing should be to scale to avoid overlooking the physical requirements specified here. Estimate interconnect cables lengths for the system from the drawing. Use the worksheet in Appendix A to determine cable requirements. If the cabling is to be overhead, be sure to add enough length to the cables for the run up to the ceiling and back down to the level of the system. Tables 5-1 and 5-2 provide the details for this physical placement planning.

## PHYSICAL CHARACTERISTICS

Physical characteristics of the ARIX 800/825 system are summarized in Table 5-1.

**Table 5-1. Physical Characteristics**

HEIGHT	WIDTH	DEPTH	WEIGHT
83.8 cm (33.0 in)	28.6 cm (11.25 in)	78.7 cm (31.0 in)	79.4 kg (175 lb)

## **SPACE REQUIREMENTS**

See clearance bullet on Page 1-2 for space requirements.

## **FLOOR LOADING**

Raised or reinforced floors are not required for ARIX systems. Raised floors in existing installations can be used for convenience, but the additional strength of the reinforced floor structure is not required. Nominal floor loading for the systems is less than two pounds per square inch, which is approximately the same as a person of average weight would exert while standing on the floor.

## Section 6

# Cabling Considerations

The planning and preparation for use of the ARIX system must take into consideration all the terminals, printers, modems, and other devices in the system configuration.

Considerations affecting the planning of a system cabling installation include the following:

- Matching cables by connector type and gender.
- Matching cables by pinout or conductor usage.
- Determining cable length and routing.
- Identifying (and avoiding) ambient noise sources.
- Locating usable (existing) on-site cables.
- Determining lead times to make or buy cables.

## CABLE LENGTH

Cable length is defined as the plug-to-plug distance between items of equipment. Routing requirements must be considered when planning a cable installation (conduit, corners, rises, drops, stress relief, etc.) in addition to excess length to accommodate equipment positioning. Excess length of cable should be folded carefully into protected areas such as cable runs or overhead. Do not coil unshielded cables and place them together.

## CABLE ROUTING

Cable routing is normally within the premises of the user. When cable must be routed outside the premises, consult the common carrier or local utility for applicable regulations.



## CABLE CONNECTORS

Cable connectors should be secured at the point where they are mounted. For best results, use the type of connectors that screw together.

## NOISE ENVIRONMENT

Ambient electrical noise (radiation) produced by equipment such as motor generators, electromechanical devices, radiation equipment, or existing wiring and cabling, can cause errors in data processing equipment. If such conditions exist, shielded cable must be considered for the installation. In addition, special grounding requirements may be considered.

## CABLE TYPE

Cabling, generally, includes both unshielded and shielded types. Shielded cables are available in two types: one for above ground use (aerial or duct) and the other for underground installation (burial). Unshielded cable is typically used in the least demanding applications, such as short runs inside a building.

## EXISTING ON-SITE CABLES

To use existing on-site cables with the ARIX system, first verify that the connectors and internal conductors are compatible. Refer to *Section 5* in the *Installation and Maintenance Manual for the ARIX Models 800 and 825* for pin usage or signal definitions.

### NOTE

Ownership of existing on-site cabling (i.e., whether the user owns or leases it) must be determined before any use can be made. The use of leased cables on other than the original equipment may be contrary to the policy of the particular original equipment manufacturer.

## ARIX SYSTEM CABLES

Several types of communications cables can be connected to the system. All cables are designed to meet RS-232C or Centronics interface requirements.

Each interface has a different set of signal interconnect requirements. Console and remote diagnostic cables require male DB-25 pin connectors at the system end. The terminal end is dependent on the type of terminal used. Terminal cables require a RJ-12/RJ-11 connector at one end and a DB-25 connector at the other end. The cable for a parallel printer requires a DB-37 connector at one end and a Centronics-style ribbon cable connector at the other end. For more information about cables, pins, etc., refer to Section 5 of the *Installation and Maintenance Manual*.

ARIX supports a 50 ft. RS-232C cable for each connection to the system. The length of the power cord is 1.9 m (6.0 ft).

## Section 7

# Planning and Preparation Checklist

The checklist in the following table is intended to help plan for and prepare the site where the computer system will be located. The time period shown in the checklist is estimated and can be modified to fit specific requirements. When ready, fill in the "Planned Date" column. As each item in the checklist is completed, record the date in the "Completion Date" column.

### Recommended Site Planning and Preparation Checklist

(Part 1 of 5)

Planning and Preparation Steps	Planned Date	Completion Date
<b>INITIAL PLANNING</b>		
1. Review description of system to be installed to become familiar with options and peripherals, and uses of the equipment in the system.		
2. Review content of this site preparation guide.		
3. Prepare an initial layout showing locations of all equipment.		

**Recommended Site Planning and Preparation Checklist**

(Part 2 of 5)

Planning and Preparation Steps	Planned Date	Completion Date
<b>90 DAYS BEFORE DELIVERY</b>		
1. Determine space requirements.		
2. Check site dimensions and building access dimensions and prepare a layout showing each peripheral located at its selected site. Include any structural changes or relocation of other equipment which could affect the installation of peripherals or cables.		
3. Select the location of power receptacles for peripherals to provide maximum flexibility for positioning the equipment and for ease of maintenance.		
4. Determine the method of installation and suitable routing of signal cables, which include cables between the host processor (direct connection), terminals, and printers.		
5. If any cables are to be installed during site preparation, request delivery early enough to meet site preparation schedule.		
6. If necessary, revise planning schedules to meet equipment delivery schedules.		

## Recommended Site Planning and Preparation Checklist

(Part 3 of 5)

Planning and Preparation Steps	Planned Date	Completion Date
<b>60 DAYS BEFORE DELIVERY</b>		
1. Check environment at selected site for compliance with requirements. Arrange necessary rework of lighting and air conditioning, if necessary.		
2. Compare electrical facilities with power requirements of the ordered equipment to ensure compatibility. If not compatible, call an ARIX Customer Support Representative to change the facilities, as required.		
3. Make final adjustments to planned layout of data communications devices, peripherals, and cables.		

**Recommended Site Planning and Preparation Checklist**

(Part 4 of 5)

Planning and Preparation Steps	Planned Date	Completion Date
<b>30 DAYS BEFORE DELIVERY</b>		
1. Start installation or improvement of air conditioning, if required.		
2. Start any structural modifications required for cable routing or for preparing the work area.		
3. Install wiring, circuit breakers and required electrical receptacles.		

## Recommended Site Planning and Preparation Checklist

(Part 5 of 5)

Planning and Preparation Steps	Planned Date	Completion Date
<b>7 DAYS BEFORE DELIVERY</b>		
1. Check electrical, structural, and air conditioning installation. (This work should be completed by this time.)		
2. Before the arrival of equipment, make sure that the appropriate cables have been properly installed.		
3. Make sure preparations have been completed for interconnect cables to be installed when the equipment is installed.		
4. Complete painting, draping, and carpeting of the site, if necessary.		
5. Make sure desks, tables, chairs, storage cabinets, and other furnishings needed at the site are available for the installation.		
6. Apply static-discharge treatment to the carpeting, if required.		
7. Clean the site location.		

## Appendix A

# Cable Planning Chart

This appendix contains instructions and a planning chart for use in defining the cable configurations for an ARIX system. Once each cable is defined, use this appendix as a build order.

The charts that follow are designed to describe the configuration of each cable, port-by-port as it attaches to the ARIX system. The items in the chart are used as follows:

### Port Number

This is the number of the attachment point on the ARIX system. Each GC/IOCP board and its related interface provides 8 serial ports and 1 parallel or Centronics-type port. Typically, port numbering begins with zero, making the eighth port number seven. The second GC/IOCP board, for layout purposes, is numbered 8 through 15, and so on.

### Port Type

Each GC/IOCP board that provides for synchronous communication uses Ports 0 and 1. All eight serial ports (numbered 0-7) provide for asynchronous communication. Check the manual for the device to be attached to determine whether the device is asynchronous or synchronous. Typically, terminals are set up as asynchronous devices, and attachments to modems or to other computers may be synchronous.

### Device Type

Terminals and serial printers are Data Terminal Equipment (DTE). Modems are Data Communication Equipment (DCE). Adjustments for differences between DTE and DCE can be made on the GC/IOCP interface board. The port should be configured opposite to the type of equipment to be connected to it. See the *Installation and Maintenance Manual* for details. Label each port for device type and name. For example, a port designated for a terminal/printer should be configured and labeled as DCE.

### Cable Type

This is the physical description of the cable to be used. Read the manual for the device to determine what it requires. Ribbon cable is typically used for attaching modem-type devices. Shielded cable provides some protection



against noise from outside sources. In many cases, careful routing to keep the cable away from noise sources may be as important as the shielding. Four-conductor and six-conductor designations refer to the number of wires in the cable. Do not use cable designed for indoor use outside. If the cable length is greater than 50 feet, consider the use of short-haul modems or other types of line repeaters.

### Cable Length

This is defined as the length of cable from the attachment point on the lower back panel to the device. The horizontal run can be estimated from the floor plan for the site. Allow sufficient length at the device end in case it might be moved later. The vertical run is simply the distance up or down, or up and down, that the cable has to cover that does not show on the two-dimensional floor plan. Add the two lengths for the total length.

### Cable Connectors

The typical connector for an RS232C interface is a DB-25 pin connector. On the system end, ports that provide for synchronous communication require this DB-25 pin connection. Asynchronous communication ports on the 800/825 require an RJ11 (4 pin) or RJ12 (6 pin) for serial communication. For these ports, a DB-25 connector is not used on the system end. Terminal ends use a DB-25 pin connector at **one end only**. This end requires either a special cable or an adjustment to the DB-25 connector so that the following RS232 equivalent connection is made:

Signal Names	DB-25 Pin Numbers	RJ-12/RJ-11 Pin Numbers
TX	2	2
RX	3	3
SG	7	4
DTR	20	5
DSR	6	1
DCD	8	6

The Centronics parallel interface on the Model 800/825 requires a female DB37 style connector. Most parallel printers use a 36 pin Centronics-style connector. The simplest way to create an adapter cable is to use a 36 pin ribbon cable with a DB-37 ribbon cable connector at one end, and a Centronics-style ribbon cable connector at the other end. Aligning each end on Pin 1 will provide the correct signals between the system and the printer.

**Serial Connectors**

		Port Number			
		0	1	2	3
<b>Port Type</b>	Synchronous			N/A	N/A
	Asynchronous				
<b>Device Type</b>	DTE or DCE				
<b>Cable Type</b>	Ribbon				
	Shielded				
	4-Conductor				
	6-Conductor				
<b>Cable Length</b>	Horizontal				
	Vertical				
	Total				
<b>Cable Connectors</b>	System-End	DB25 Female	DB25 Female	RJ-12/11	RJ-12/11
	Device-End				

		Port Number			
		4	5	6	7
<b>Port Type</b>	Synchronous	N/A	N/A	N/A	N/A
	Asynchronous				
<b>Device Type</b>	DTE or DCE				
<b>Cable Type</b>	Ribbon				
	Shielded				
	4-Conductor				
	6-Conductor				
<b>Cable Length</b>	Horizontal				
	Vertical				
	Total				
<b>Cable Connectors</b>	System-End	RJ-12/11	RJ-12/11	RJ-12/11	RJ-12/11
	Device-End				

**Serial Connectors (Cont.)**

		Port Number			
		8	9	10	11
<b>Port Type</b>	Synchronous			N/A	N/A
	Asynchronous				
<b>Device Type</b>	DTE or DCE				
<b>Cable Type</b>	Ribbon				
	Shielded				
	4-Conductor				
	6-Conductor				
<b>Cable Length</b>	Horizontal				
	Vertical				
	Total				
<b>Cable Connectors</b>	System-End	DB25 Female	DB25 Female	RJ-12/11	RJ-12/11
	Device-End				

		Port Number			
		12	13	14	15
<b>Port Type</b>	Synchronous	N/A	N/A	N/A	N/A
	Asynchronous				
<b>Device Type</b>	DTE or DCE				
<b>Cable Type</b>	Ribbon				
	Shielded				
	4-Conductor				
	6-Conductor				
<b>Cable Length</b>	Horizontal				
	Vertical				
	Total				
<b>Cable Connectors</b>	System-End	RJ-12/11	RJ-12/11	RJ-12/11	RJ-12/11
	Device-End				

**Serial Connectors**

		Port Number			
		16	17	18	19
<b>Port Type</b>	Synchronous			N/A	N/A
	Asynchronous				
<b>Device Type</b>	DTE or DCE				
<b>Cable Type</b>	Ribbon				
	Shielded				
	4-Conductor				
	6-Conductor				
<b>Cable Length</b>	Horizontal				
	Vertical				
	Total				
<b>Cable Connectors</b>	System-End	DB25 Female	DB25 Female	RJ-12/11	RJ-12/11
	Device-End				

		Port Number			
		20	21	22	23
<b>Port Type</b>	Synchronous	N/A	N/A	N/A	N/A
	Asynchronous				
<b>Device Type</b>	DTE or DCE				
<b>Cable Type</b>	Ribbon				
	Shielded				
	4-Conductor				
	6-Conductor				
<b>Cable Length</b>	Horizontal				
	Vertical				
	Total				
<b>Cable Connectors</b>	System-End	RJ-12/11	RJ-12/11	RJ-12/11	RJ-12/11
	Device-End				

**Serial Connectors**

		Port Number			
		24	25	26	27
<b>Port Type</b>	Synchronous			N/A	N/A
	Asynchronous				
<b>Device Type</b>	DTE or DCE				
<b>Cable Type</b>	Ribbon				
	Shielded				
	4-Conductor				
	6-Conductor				
<b>Cable Length</b>	Horizontal				
	Vertical				
	Total				
<b>Cable Connectors</b>	System-End	DB25 Female	DB25 Female	RJ-12/11	RJ-12/11
	Device-End				

		Port Number			
		28	29	30	31
<b>Port Type</b>	Synchronous	N/A	N/A	N/A	N/A
	Asynchronous				
<b>Device Type</b>	DTE or DCE				
<b>Cable Type</b>	Ribbon				
	Shielded				
	4-Conductor				
	6-Conductor				
<b>Cable Length</b>	Horizontal				
	Vertical				
	Total				
<b>Cable Connectors</b>	System-End	RJ-12/11	RJ-12/11	RJ-12/11	RJ-12/11
	Device-End				

**Serial Connectors**

		Port Number			
		32	33	34	35
<b>Port Type</b>	Synchronous			N/A	N/A
	Asynchronous				
<b>Device Type</b>	DTE or DCE				
<b>Cable Type</b>	Ribbon				
	Shielded				
	4-Conductor				
	6-Conductor				
<b>Cable Length</b>	Horizontal				
	Vertical				
	Total				
<b>Cable Connectors</b>	System-End	DB25 Female	DB25 Female	RJ-12/11	RJ-12/11
	Device-End				

		Port Number			
		36	37	38	39
<b>Port Type</b>	Synchronous	N/A	N/A	N/A	N/A
	Asynchronous				
<b>Device Type</b>	DTE or DCE				
<b>Cable Type</b>	Ribbon				
	Shielded				
	4-Conductor				
	6-Conductor				
<b>Cable Length</b>	Horizontal				
	Vertical				
	Total				
<b>Cable Connectors</b>	System-End	RJ-12/11	RJ-12/11	RJ-12/11	RJ-12/11
	Device-End				

**Parallel Connectors**

		Port Number				
		0	1	2	3	4
<b>Cable Type</b>	Ribbon					
	Shielded					
<b>Cable Length</b>	Horizontal					
	Vertical					
	Total					
<b>Cable Connectors</b>	System-End	DB-37	DB-37	DB-37	DB-37	DB-37
	Device-End					





**ARIX CORPORATION**



**Models 825 And 800  
Installation And Maintenance  
Manual**

**Part Number MA-99236-00**

**Revision B**

**Copyright 1989**

**821 Fox Lane  
San Jose, Ca 95131**

**FCC WARNING:**

This equipment generates, uses, and can radiate radio frequency (RF) energy, and if not installed and used in accordance with the information provided by ARIX, may cause interference to radio communications. It has been tested and found to comply with the limits for Class A computing device pursuant to Subpart J of Part 15 of FCC rules, which are designed to provide reasonable protection against such interference when operated in a commercial environment. Operation of this equipment in a residential area is likely to cause interference, in which case the user, at his own expense, will be required to take whatever measures may be required to correct the interference.

Copyright 1989, ARIX Corporation

This document contains the latest information available at the time of preparation. This document contains descriptions of functions available for the 800 and 825 systems. Ensure that the latest information is available by contacting your ARIX representative.

ARIX Corporation reserves the right to modify or revise the content of the document. Contractual obligation of this document by ARIX Corporation regarding level, scope, or timing of functional implementation is not expressed or implied. It is further understood that in consideration of the receipt or purchase of this document, the recipient or purchaser agrees not to reproduce or copy it by any means whatsoever, nor to permit such action by others, for any purpose without prior written permission from ARIX Corporation.

ARIX is a registered trademark of ARIX Corporation.

UNIX is a registered trademark of AT&T.

This is the installation and maintenance manual for the models 825 and 800 systems. Reference throughout this manual to the 825 or 800 systems is 825/800.

This manual consists of instructions and procedures required to install, remove, test, and maintain the model 825/800 systems.

An overview of the buses, applications and Input/Output (I/O) processors, Printed Circuit (PC) boards, and other components is also included in this manual.

The intended audience for this manual is Field Engineers (FEs), Customer Support personnel, System Administrators and personnel with a technical (hardware) background.

## **ORGANIZATION**

This manual was organized to provide the installation procedures of the system, boards, and peripherals, and the maintenance procedures for major field replaceable parts of the 825/800 ARIX systems.

Also contained in this manual are preventive maintenance procedures, functional operations of the entire system, cable pin settings, and information about subassemblies contained in older systems.

## **CONVENTIONS**

The documentation methods used in this manual are as follows:

- Where there are command line strings, "0" is the number zero, not the capital letter "O".
- User command entries and/or actions are shown in bold, for example:
  - <cr> is a carriage return, pressing the carriage return once.
  - <sp> is a space, pressing the space bar once.
  - <esc> is an escape, pressing the escape key once.
- ARIX System prompts and responses are shown in **Monaco** font.
- A control-command-character is pressing the control (Ctrl) key, and the specified character key at the same time. For example, a control-z is shown as <Ctrl-Z>.
- xxxx, or XXXX represents numbers in octal, hexadecimal, or decimal notation.

All WARNINGS, CAUTIONS, and NOTES are defined as follows:

**WARNING:**

A **WARNING** calls attention to the previous procedure that may result in personal injury if improperly performed.

**CAUTION:**

A **CAUTION** calls attention to the previous procedure that may result in damage to the equipment if improperly performed.

**NOTE:**

A **NOTE** calls attention to, and stresses the importance of, a situation documented in the associated text.

# Contents

<b>Introduction</b> .....	<b>1-1</b>
<b>Main Cabinet Installation</b> .....	<b>2-1</b>
<b>System Startup and Shutdown</b> .....	<b>3-1</b>
AC Power Cord Installation .....	3-2
Power-Up Procedure .....	3-6
Booting The System .....	3-7
Booting from Tape (bt<sp>) .....	3-8
Transferring Boot Image to Disk (ldsa) .....	3-9
Booting from Disk (b<sp>) .....	3-10
Disk Test (disktest) .....	3-11
Checking and Updating Disk Status .....	3-13
Disk Drive Formatting .....	3-14
OPTION f, Format Drive .....	3-14
Read/Write Test .....	3-16
OPTION a, Change Parameters .....	3-16
OPTION d, Read/Write Test .....	3-17
Halting Read/Write Test And Recording Errors .....	3-18
Disk Setup (dsetup) .....	3-19
Logical Disk Types .....	3-21
Running The dsetup Program .....	3-22
dsetup Commands .....	3-27
Multi-User State .....	3-29
System Shutdown .....	3-31
Power Removal .....	3-33
<b>Printed Circuit Boards</b> .....	<b>4-1</b>
CPU32 Master/Slave Selection .....	4-4
PC Board Removal And Installation .....	4-6
Logic Board Removal and Installation .....	4-6
Logic Board Removal .....	4-7
Logic Board Installation .....	4-8
Interface Board Removal And Installation .....	4-10
Interface Board Removal .....	4-10
Interface Board Installation .....	4-11
GC/EGC/GC16 Interface Board Setup .....	4-13
GC/EGC DCE/DTE Port Configuration .....	4-14
GC16 DCE/DTE Port Configuration .....	4-16
SCSI Interface Board Setup .....	4-18
Single-ended Mode Configuration .....	4-18
Differential Mode Configuration .....	4-18
Multibus Adapter Card Setup .....	4-20
VMEbus Adapter Card Setup .....	4-22

<b>Terminals, Printers, And Modems.....</b>	<b>5-1</b>
The RS-232C Standard .....	5-1
Console Terminal Installation .....	5-3
CPU32 Remote Diagnostic Console .....	5-5
Multiple Terminal Installation .....	5-6
Printer Installation .....	5-8
Modems .....	5-9
<b>Subassembly Removal And Installation.....</b>	<b>6-1</b>
Internal Drive Storage Area.....	6-2
Accessing The Internal Drive Storage Area .....	6-2
Reassembly Of The Internal Drive Storage Area .....	6-3
Cartridge Tape Drive Assembly.....	6-4
Removing a Cartridge Tape Drive.....	6-4
Installing a Cartridge Tape Drive.....	6-6
Keyswitch Assembly.....	6-7
Removing the Keyswitch Assembly .....	6-7
Installing the Keyswitch Assembly .....	6-7
Fan Assembly .....	6-8
Main Fan Assembly.....	6-9
Removing the Main Fan Assembly.....	6-9
Installing the Main Fan Assembly .....	6-9
Drive Storage Fan Assembly .....	6-10
Removing The Drive Storage Fan Assembly.....	6-10
Installing The Drive Storage Fan Assembly .....	6-10
Disk Drive Assemblies .....	6-11
Vertical HSMD/SMD Disk Drives .....	6-12
Removing a Vertical-Mount HSMD/SMD Disk Drive.....	6-12
Installing a Vertical-Mount HSMD/SMD Disk Drive.....	6-14
Vertical SCSI Disk Drives .....	6-16
Removing a Vertical-Mount SCSI Disk Drive.....	6-16
Installing a Vertical-Mount SCSI Disk Drive.....	6-18
Horizontal SCSI Disk Drives.....	6-21
Removing a Horizontal-Mount SCSI Disk Drive .....	6-21
Installing a Horizontal-Mount SCSI Disk Drive .....	6-22
Power Supply Assembly .....	6-25
Removing the Power Supply Assembly.....	6-25
Installing the Power Supply Assembly .....	6-26
Power Supply Voltage Setting .....	6-27

<b>Peripherals .....</b>	<b>7-1</b>
Expansion Cabinet.....	7-2
Cartridge Tape Drives .....	7-4
Archive Viper Cartridge Tape Drives .....	7-4
Wangtek Cartridge Tape Drives .....	7-4
9-Track Operation.....	7-6
9-Track Device Numbering Scheme .....	7-6
Cipher 9-Track Operation .....	7-8
Disk Drives .....	7-10
SCSI Optical Disk Drives .....	7-10
Fujitsu Disk Drives.....	7-10
SCSI Disk Drives .....	7-11
Modular Communications Processor.....	7-12
MCP Installation.....	7-12
<b>Preventive Maintenance .....</b>	<b>8-1</b>
System Exterior .....	8-1
System Fan Filters.....	8-2
Cartridge Tape Drives .....	8-2
Archive Viper Cartridge Tape Drives .....	8-3
Wangtek Cartridge Tape Drives .....	8-4
Cipher 9-Track Tape Drive .....	8-5
<b>Functional Operations.....</b>	<b>9-1</b>
Bus System.....	9-2
Communications and Control Bus (CCB).....	9-2
Processor Memory Bus (PMB) .....	9-2
Mass Storage Bus (MSB) .....	9-3
Utility Transfer Bus (UTB) .....	9-3
Backplane .....	9-4
Computational Subsystem .....	9-5
Application Processor.....	9-5
Multiple AP Capabilities.....	9-5
Memory Management Unit (MMU).....	9-6
Cache Memory.....	9-6
Cache Theory.....	9-7
Cache Data Bits .....	9-7
Cache Tag Bits .....	9-7

Processor I/O .....	9-8
System Console Port .....	9-8
System Status Input Register .....	9-8
Diagnostic LED Display .....	9-9
PROM Monitor .....	9-9
Direct Memory Controller (DMC) .....	9-9
CCB Interface .....	9-10
PMB Interface .....	9-10
Direct Memory Access Control .....	9-11
Memory Refresh Control .....	9-11
Error Detection And Correction (EDAC) .....	9-11
Memory Board .....	9-12
Memory Organization And Performance .....	9-12
CCB Interface .....	9-13
PMB Interface .....	9-13
Input/Output Subsystem .....	9-14
Database Processor (DP) .....	9-14
Communications And Control Bus Interface .....	9-14
Data Bus Control (DBC) .....	9-14
Mass Storage Bus Interface .....	9-15
Interface Bus (IB) .....	9-15
Disk and Tape Drive .....	9-15
Intelligent Communications Processor (ICP) .....	9-16
CCB Interface .....	9-16
Processor And Memory Section .....	9-17
I/O Section .....	9-17
Software Description .....	9-17
Hardware Reliability .....	9-17
Temperature Monitors .....	9-17
<b>Technical Support .....</b>	<b>A-1</b>
<b>Glossary .....</b>	<b>G-1</b>



## Tables

Table 1-1.	Base Configuration Summary of Model 825/800 .....	1-2
Table 1-2.	ARIX System Power Capacities.....	1-2
Table 1-3.	Maximum Cabinet Capacities .....	1-3
Table 4-1.	I/O Family Related Boards .....	4-3
Table 4-2.	DP/ICP Device Support .....	4-3
Table 4-3.	DP Logic Board Device Support .....	4-3
Table 4-4.	Card Cage Slot Assignments.....	4-4
Table 4-5.	GC/EGC DCE/DTE Port Configuration.....	4-14
Table 4-6.	GC16 DCE/DTE Port Configuration.....	4-16
Table 5-1.	EIA Voltage Definition.....	5-1
Table 5-2.	Serial RS-232C And RJ-12 Signal Summary.....	5-2
Table 7-1.	825/800 Expansion Cabinet Maximum Capacities .....	7-1
Table 7-2.	9-Track Tape Drive Devices.....	7-6
Table 7-3.	9-Track Bit Map .....	7-7
Table 7-4.	9-Track Options.....	7-8
Table 9-1.	System Status Error Codes.....	9-9

# Figures

Figure 1-1.	ARIX Model 825/800.....	1-4
Figure 3-1.	Rear Panel.....	3-3
Figure 3-2.	Front Panel.....	3-4
Figure 3-3.	AC Power Connections .....	3-5
Figure 4-1.	Logic and Interface Boards .....	4-2
Figure 4-2.	CPU Master/Slave Switch .....	4-5
Figure 4-3.	GC/EGC Interface Board .....	4-15
Figure 4-4.	GC16 Interface Board .....	4-17
Figure 4-5.	SCSI Interface Board .....	4-19
Figure 4-6.	Multibus Adapter Card with Multibus Board .....	4-21
Figure 4-7.	VMEbus Adapter Card with VMEbus Board .....	4-23
Figure 5-1.	Model 825/800, Rear View .....	5-4
Figure 6-1.	Internal Rear View .....	6-5
Figure 6-2.	Internal Front View .....	6-8
Figure 6-3.	SMD Disk Drive Settings .....	6-13
Figure 6-4.	Vertical-Mount HSMD/SMD Drives .....	6-15
Figure 6-5.	Vertical-Mount SCSI Drives .....	6-17
Figure 6-6.	CDC 170 Mbyte SCSI Disk Drive Settings .....	6-19
Figure 6-7.	CDC 380 Mbyte SCSI Disk Drive Settings .....	6-20
Figure 6-8.	Horizontal-Mount SCSI Drives.....	6-23
Figure 6-9.	Power Supply, Front View .....	6-28
Figure 6-10.	Power Supply, Rear View .....	6-29
Figure 7-1.	Expansion Cabinet .....	7-2
Figure 7-2.	Expansion Connector Panel.....	7-3
Figure 7-3.	Archive Viper Tape Drive (Front View).....	7-5
Figure 7-4.	Cipher Control Panel.....	7-9
Figure 7-5.	MCP Connections.....	7-13
Figure 8-1.	Cipher Air Filter Removal.....	8-6
Figure 8-2.	Cipher 9-track Maintenance Locations.....	8-7

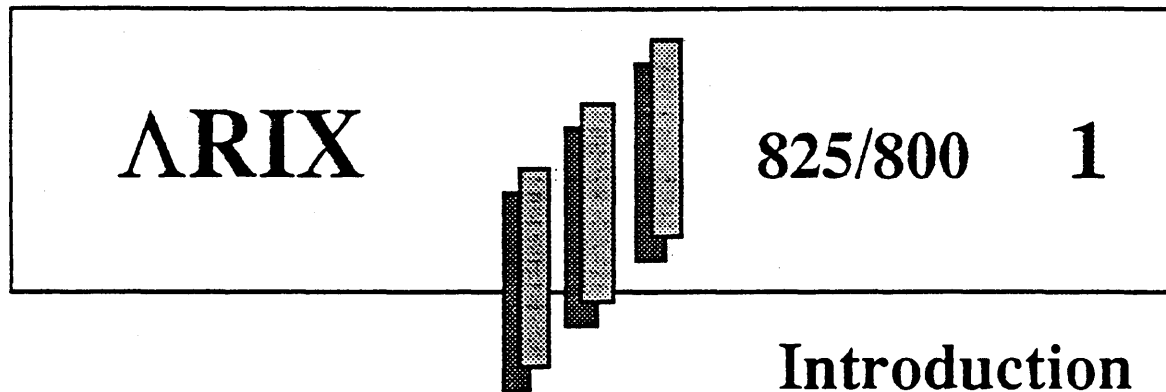

ARIX systems are high-performance, UNIX multi-application processing computers designed to quickly and reliably handle the high demands of multiple user-intensive applications and throughput, for commercial applications.

The ARIX models 800 and 825 are functionally identical in bus structure and are referred to as the 825/800 throughout this manual.

The 825/800 systems support up to 10 boards: three MEMORY/CPU, one DMA controller (DMC2 or DMC4/2), and six Intelligent Communication Processor (ICP) boards.

The tables and figures in this section describe the ARIX system, as follows:

- Table 1-1 is a base configuration summary of the models 825/800
- Table 1-2 shows the system power capacities.
- Table 1-3 shows the maximum main cabinet capacities of the 825/800 systems.
- Figure 1-1 is a front view of the model 825/800; notice the tape cartridge.

Expansion Cabinets are used to house additional disk, cartridge, and/or 9-track tape drive devices and are added to the system to extend the peripheral device support capacity.

Table 1-1. Base Configuration Summary of ARIX 825/800

Qty.	Description	
	Model 825	Model 800
1	800 Cabinet	
1	Backplane	
1	850 Watt Power Supply	
1	DMC4 or DMC4/2	
1	GC Interface Board	
1	Cartridge Controller Interface Board	
1	25 MHz CPU32	12.5 MHz CPU32
1	8 Mbyte Memory Card	4 Mbyte Memory Card
1	EDT Board	HSDT Board
1	EGC Board	GC Board
1	172 Mbyte Disk Drive	172 Mbyte Disk Drive
1	150 Mbyte Cartridge Tape Drive	60 Mbyte Cartridge Tape Drive

Table 1-2. ARIX System Power Capacities

System Component	Maximum Capacity	Current Source (Amps)		
		+5V	+12V	-12V
Power Supply (Kilowatts)	1.8	120	16	6

Table 1-3. Maximum Cabinet Capacities

System Components	800	825
<b>Disk Drives</b> SMD 172 Mbyte SCSI 170 Mbyte SCSI 380 Mbyte	3	3
<b>Cartridge Tape Drives</b> 60 Mbyte 150 Mbyte	1	1
<b>Maximum Board Capacity</b>	10	10
<b>CPU and Memory Boards Total</b>	3	3
<b>CPUs</b> 12.5 MHz CPU32 25 MHz CPU32	2	2
<b>Main Memory (Mbytes)</b>	16	64
<b>DMA Controller (one per system)</b> DMC4/2 (setup as a DMC2)	1	1
<b>Disk Tape Controllers</b> HSDT EDT SCSI	2	2
<b>ICP boards</b> GC8 EGC GC16	5	5

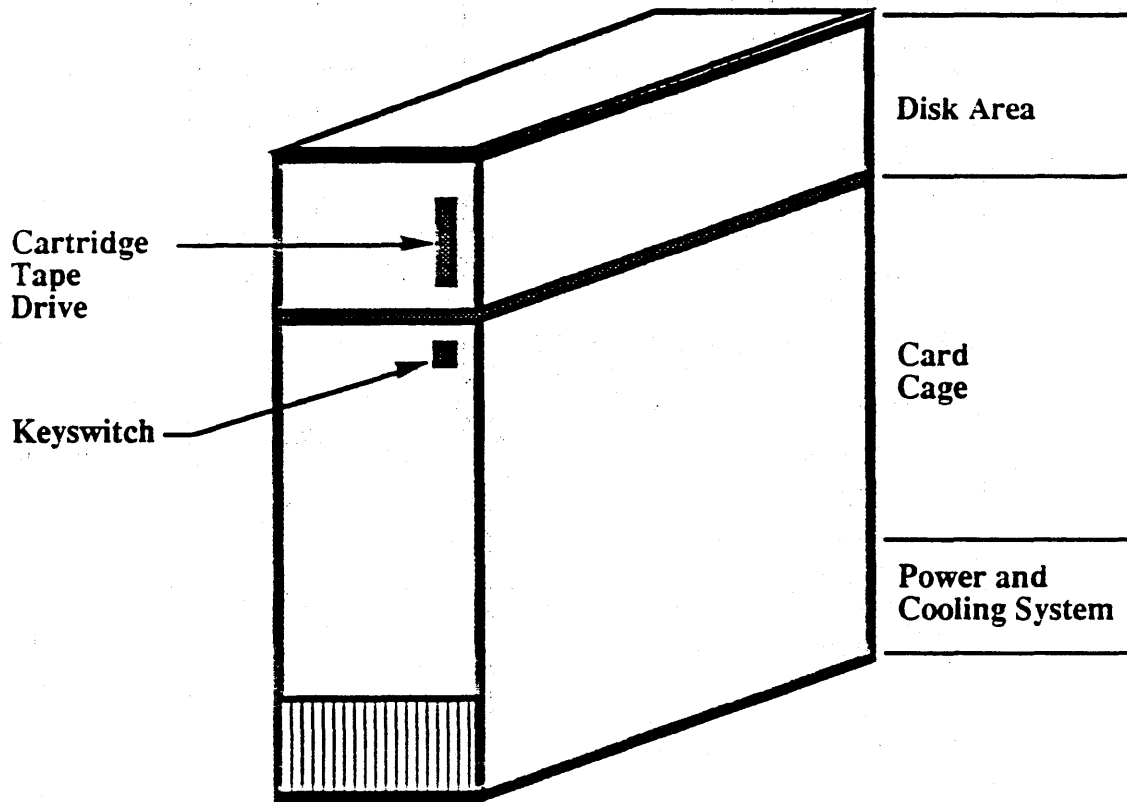
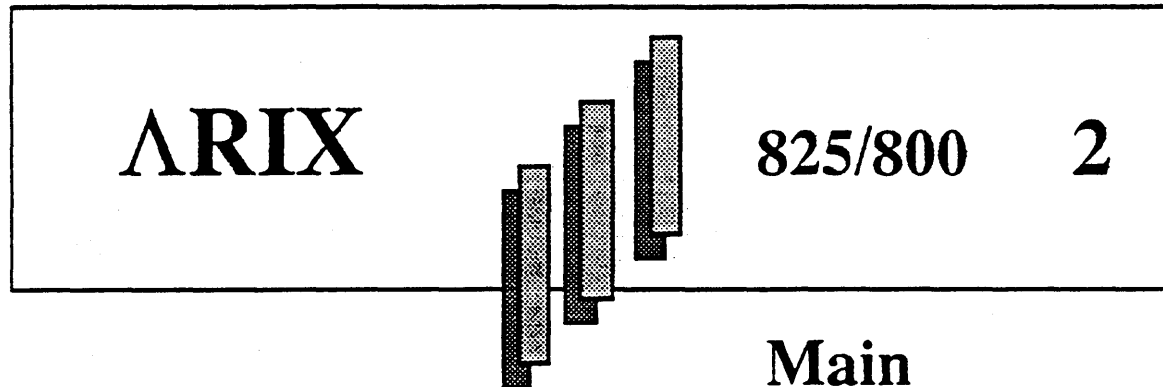

Figure 1-1. Model 825/800



**ARIX** 825/800 2

# Main Cabinet Installation

This section outlines the non-electrical installation procedures required to level and secure the main system cabinet. Read and understand these procedures prior to starting any installation.

Failure to comply with these procedures may invalidate some of the ARIX certifications or the system's warranty.

**WARNING:**

Electrical shock or system damage may result if the installation procedures are performed without disconnecting power to the system. When installing or adjusting the brackets for multiple systems, always remove power from the system. (Refer to Section 3, *System Startup and Shutdown*.)

All ARIX systems contain four adjustable mounting pads (feet) located underneath the system, one mounting pad at each corner. Above each mounting pad is a 9/16-inch locking nut that locks the mounting pad in position.

The following tools are required to install the main cabinet:

- a floating bubble level; to level the cabinet
- a measuring tape or ruler; to verify sufficient access space
- a 9/16-inch open-end wrench; to secure the nuts that lock the mounting pads in place
- a 1/2-inch open-end wrench; to extend or retract the mounting pads

The process to install the main cabinet includes verifying the level of the cabinet, adjusting the mounting pads until level is reached, and locking the mounting pads with the 9/16 nuts.

Multiple 825/800 systems are not bolted together. Install the 825/800 main cabinet, as follows:

1. Place the system in the desired location.

**NOTE:**

Do not plug in the system.

2. Verify that there is 45 inches of service access space in the front and rear of the main cabinet.
3. Loosen all four of the 9/16-inch locking nuts located above the mounting pads.
4. Using the floating-bubble level, check for level along the longest dimension (length). Check for level along the shortest dimension (width).

If the system is level, extend the mounting pads to the floor and secure them. Check the cabinet for wobble and re-adjust the feet as required, keeping the cabinet level.

If the cabinet is not level, extend the mounting pads, as follows:

1. Starting with the level along the length axis, rotate the 1/2-inch nut on the low end in a clockwise direction, raising the cabinet until it is level.
2. Check for level along the width axis of the cabinet, and rotate the 1/2-inch nut on the low end in a clockwise direction, raising the cabinet until it is level.
3. At this point, the cabinet should be level and should not wobble. If it is not level, or if it still wobbles, repeat Steps 1 and 2 until the cabinet is secure and level.
4. Without disturbing the setting of the mounting pads, carefully tighten the locking nuts.



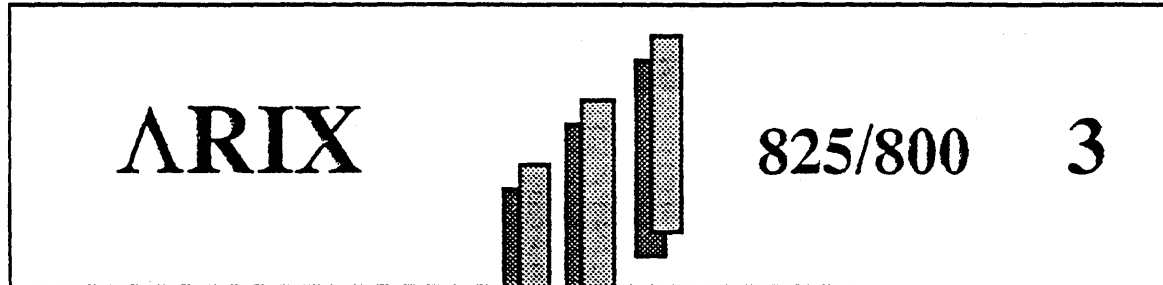

## System Startup and Shutdown

This section provides instructions to install the system AC power cord, verify and format the disk drive(s) and system power-up, boot and shutdown.

Refer to the following ARIX-OS V.3 manuals for additional information:

- *System Administrator's Reference Manual*, MA-99255-07:
  - Disk/Tape Management
  - Processor Operations
- *System Administrator's Guide*, MA-99255-06:
  - Commands (1, 1M)
- *Release 2.0 Notes*, MA-04618-XX:
  - Installation Procedures

## AC POWER CORD INSTALLATION

Before connecting the system to the primary AC power source, verify that the proper voltage, polarity, and grounding are available; check that the system is set for 110 or 220 VAC operation.

Verify that the system power switches are in the OFF position, as follows:

1. At the rear and bottom-right of the system, turn the black circuit breaker to the OFF (down) position. (Refer to Figure 3-1, *Rear Panel*.)
2. At the rear and lower middle of the system, turn the AUTO START switch to the OFF (left) position. (Refer to Figure 3-1, *Rear Panel*.)
3. At the front of the system, insert and turn the key to the OFF position. (Refer to Figure 3-2, *Front Panel*.)

From the rear of the system, the AC power cord attaches to the rear panel in the lower right corner of the main cabinet. An attachable strain relief prevents the AC power cord from being accidentally unplugged from the system.

Connect the 110 or 220 VAC line cord, as follows:

1. Plug the AC power cord into the system's power connector (refer to Figure 3-3, *AC Power Connectors*.)
2. Remove the phillips screw on the strain relief, feed the power cord through the strain relief and tighten the phillips screw to clamp down the cable.
3. Insert the AC power cord with the applicable connector into the applicable wall socket (110 or 220 VAC).

### CAUTION:

Before connecting the system to the primary AC power source, verify that the proper voltage is available. (Refer to Figure 3-3, *AC Power Connectors*.)

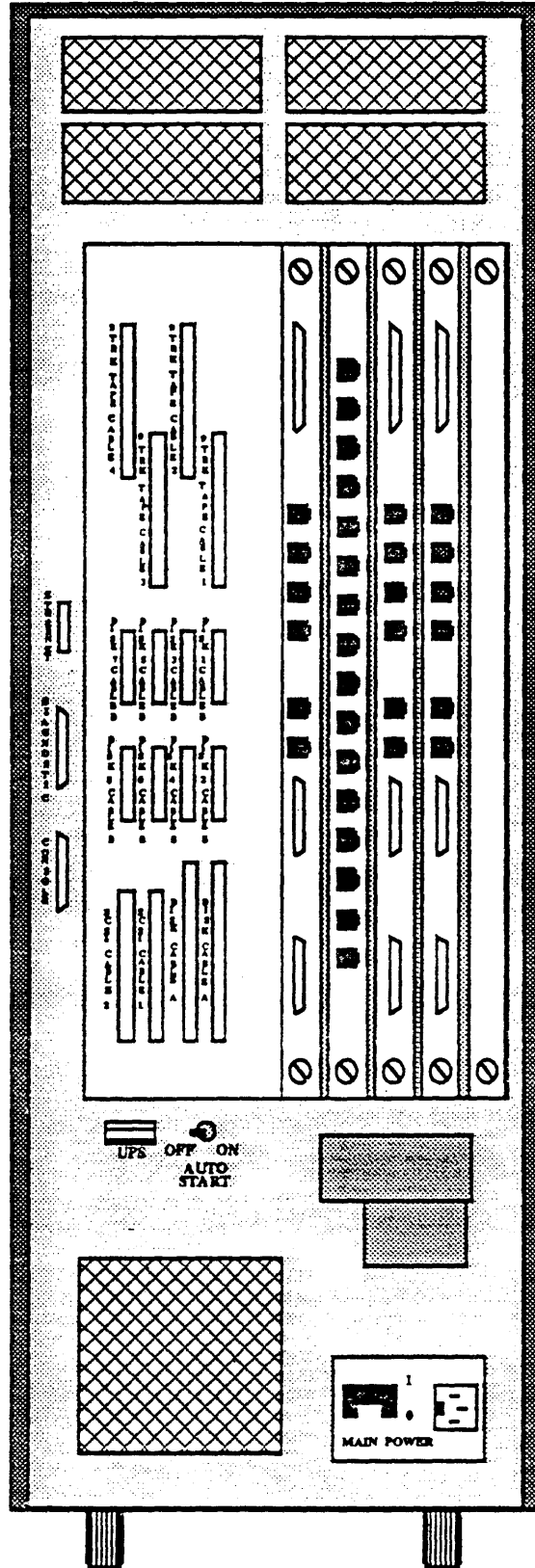

Figure 3-1. Rear Panel

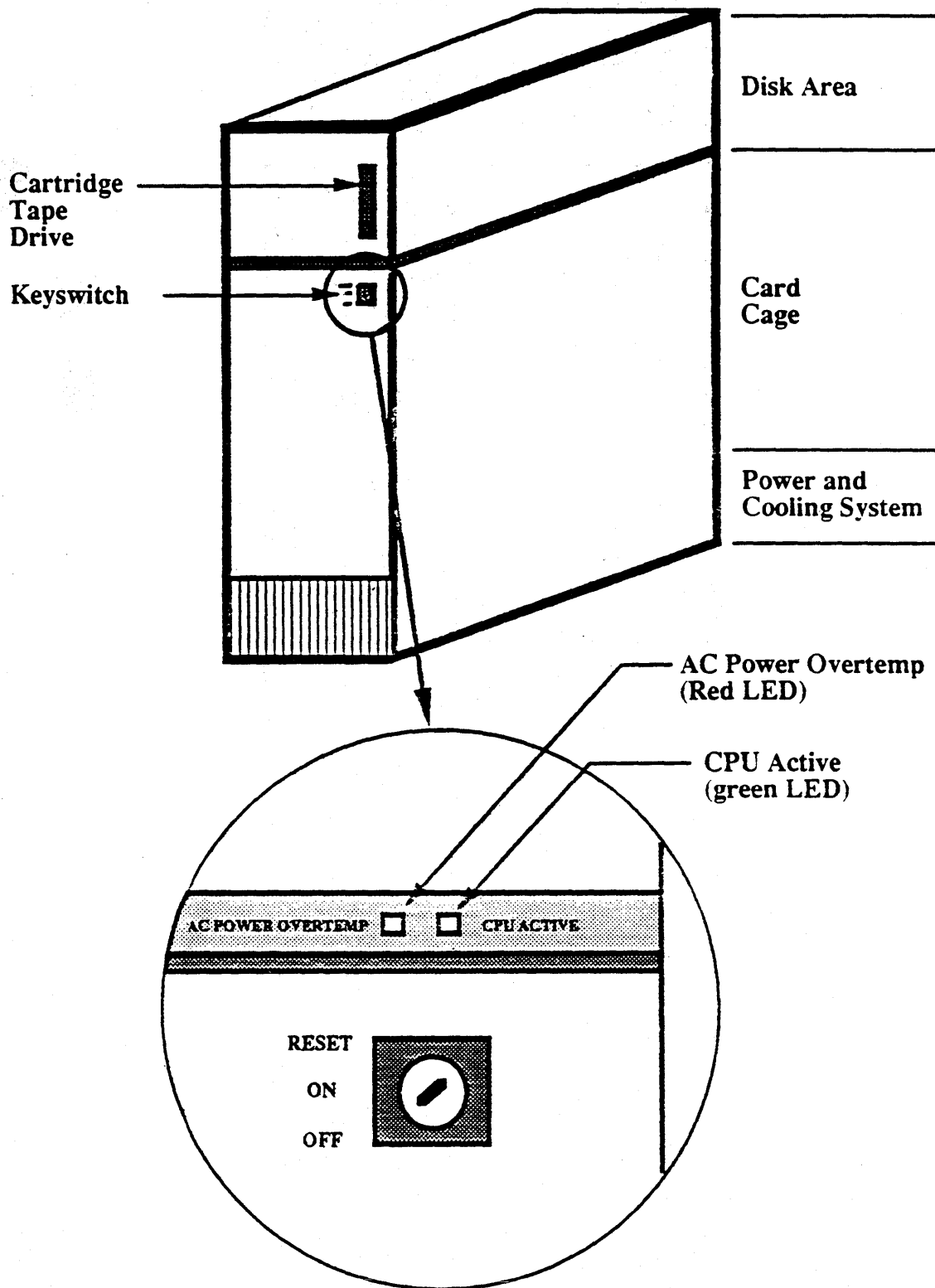

Figure 3-2. Front Panel

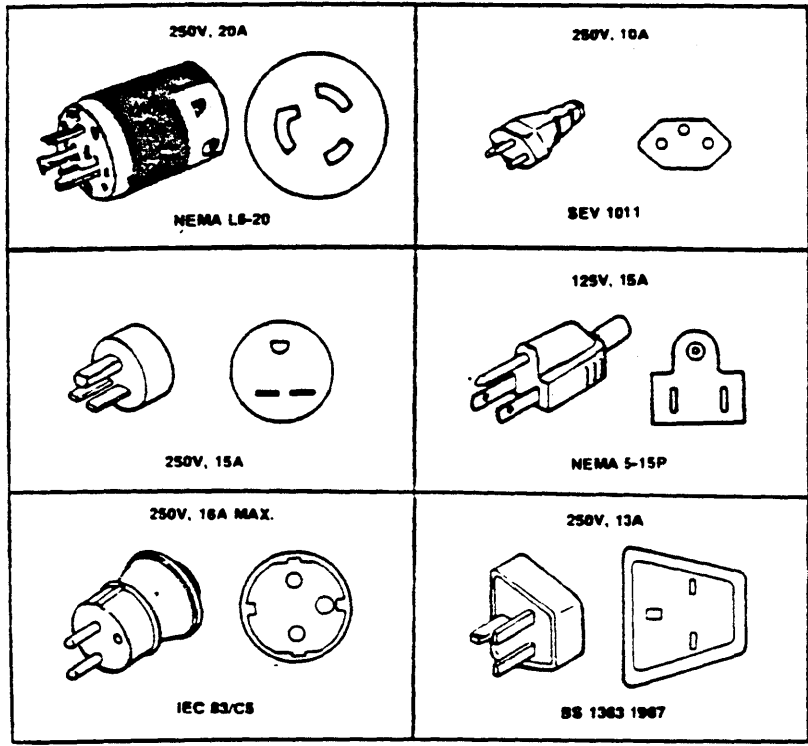

Figure 3-3. AC Power Connections

## POWER-UP PROCEDURE

Follow the procedures in the previous subsection, *AC Power Cord Installation*, before powering-up the system.

Power-up the 825/800, as follows:

1. Install the console terminal and turn it on. (Refer to Section 5, *Terminals, Printers, and Modems*). You achieve system power-up at the console.
2. From the rear of the system is the circuit breaker in the lower right corner; turn the circuit breaker to the ON or 1 (up) position.
3. Verify that the yellow indicator above the keyswitch and below the tape drive is lit. This LED indicates that external AC power is present.
4. Turn the key in the keyswitch to the ON position. Verify that the yellow indicator goes out and the green indicator lights up (indicating that the system is powered-up).
5. Verify that the cooling fans are running (located in the bottom front of the system behind the ventilation slot panel).

The system has power and the disk drive spindle has cycled up to speed. Allow all components to warm up to normal operating temperature; leave the system on for thirty minutes.

At system power-up or after reset, the system's console displays the following:

```
XXXX baud

CPU32 MONITOR Ver vX.X
power-up sequence
initializing memory *
testing edac circuitry *
testing memory *
memory edac enabled
totram XXXXXX
master cpu - slot XX
>
```

The asterisk (\*) depicts three status lines that the system flashes to the console. These are the confidence tests and are overwritten in sequence as each test passes.

Pressing the escape (<esc>) key aborts the confidence tests and the console displays the following:

```
memory edac enabled
>
```

When the > prompt appears, the system is in monitor mode. At this level, system diagnostics or boot procedures may be performed.

## **BOOTING THE SYSTEM**

When a system is booted, the system reads information from either the disk or the bootimage portion of the software release tape.

All new systems must be booted from tape for the first time. If new or updated software is being loaded, the system must be booted from tape. The program, Load-Stand-Alone (ldsa), reads the Bootimage from tape and transfers it to the reserved track of the disk.

The ARIX 4.0 operating system and CPU32 revision Bb board, and newer releases, provide an auto-boot enhancement which automatically takes the system into single-user state when either the **b<sp>** (disk boot), or **bt<sp>** (tape boot) commands are entered. There are several different prompts that must be understood to recognize the current system mode. The ARIX system prompts are, as follows:

- > The boot mode symbol signifies a system boot from tape and/or disk can be executed, or that board diagnostics can be run.
- :
- # The stand-alone mode symbol signifies that you can execute dsetup, disktest or the Load-Stand-Alone (ldsa) bootimage.
- \* The single-user mode symbol signifies that the system is ready for multiuser mode, or system administration procedures.

System name, Baud rate, login:

Represents the name of your system, the baud rate of the connection, and a request for the access-code. This display signifies multi-user mode; your system is ready to support multiple users.

The last prompt is a request for your user id and password. When the user logs in, UNIX may prompt with a \*, \$, or a %. These prompts are UNIX-defined at first, and can later be redefined by the user.

## Booting from Tape (bt<sp>)

A system is typically booted from tape when new software is to be loaded onto the disk. To boot the system from tape, the appropriate software release tape must be in the tape drive.

Boot from tape (cartridge or 9-track), as follows:

1. Insert the boot tape into the tape drive:
  - For 9-track tape systems:
    - a. Open the front door of the tape drive.
    - b. Load the "Bootimage, Root and Usr Pure" tape into the tape drive. (With the ring side of the tape down.)
    - c. Close the front door of the tape drive.
    - d. On the front control panel of the tape drive, press LOAD, then press ONLINE. The lights on the control panel will blink while the tape is forwarded and the ONLINE and LOAD lights both illuminate when the tape successfully engages.
  - For cartridge tape systems:
    - a. Insert the "Bootimage, Root, and Usr Pure" tape into the tape drive.
2. At the boot prompt (>), enter the following command:

```
>bt<sp><cr>
```

The command. bt<sp>, loads the boot program from tape. and the console displays the following:

```
Boot (UER X.XX)
Loading CCCC code (UER XXX)
x-1000 Boot
:
```

Where CCCC is either EDT, HSDT or SCSI. If the system has more than one EDT, HSDT or SCSI, the system identifies each one.

During these procedures, if a command is mis-typed and entered with a carriage return, the system must be reset by either turning the key at the front of the system to reset, or entering <ctrl-z> (press the control and z keys simultaneously with no <cr>) at the console. After resetting the system, restart the procedure at Step 2.



## Transferring Boot Image to Disk (*ldsa*)

Prior to executing the Load-Stand-Alone (*ldsa*) program, the drive must be formatted (refer to the subsection *DISK TEST*).

For the ARIX system to boot from a disk drive, the *ldsa* program must be executed. The *ldsa* program transfers the Bootimage from the selected tape drive to the selected disk drive.

The following steps describe executing the *ldsa* program, and transferring the Bootimage program through the *ldsa* program cXdX defaults (Bootimage transfer from c0d0 tape to c0d0 disk drive).

Execute the *ldsa* program, as follows:

1. At the stand-alone mode prompt (:), enter the following:

```
: ldsa<cr>
```

The console displays:

```
Stand-alone ldsa (VER 4.XX)
```

```
Source device <cr> defaults to TAPE device c0d0:
```

2. Press <cr> and the console displays:

```
Target device <cr> defaults to DISK device c0d0r:
```

3. Press <cr> and the console displays:

```
Copying BOOTIMAGE to c0d0r.
```

```
xxxxxx bytes transferred
```

```
(0) returned by exit
```

```
x-1000 Boot
```

```
:
```

The bootimage now resides on the disk selected. The user may verify this by resetting the system, and at the prompt ( > ) enter the b<sp> boot command to boot from the disk drive (refer to the following subsection).

The Bootimage can be transferred to all physical drives to allow the system to boot from any drive. For each Bootimage transfer, you must execute the *ldsa* program and specify the source drive and destination drive.

## Booting from Disk (*b<sp>*)

When you boot the system from disk, the system reads the bootimage information that was copied to the disk by the ldsa command.

Prior to entering monitor or stand-alone mode, turn the AUTO START switch on the rear of the system to the OFF position. With the AUTO START switch in the ON position, the system automatically enters single-user mode. In single-user mode, you cannot

At the boot mode symbol (>), enter the following to boot the system from disk:

```
>b<sp><cr>
```

With the AUTO START switch in the OFF position, the system enters stand-alone mode while the console displays the following:

```
Boot (UER Ax.xx)
Loading CCCC code (UER xxx)
x-1000 Boot
:
```

Where CCCC is either EDT, HSDT or SCSI. With a system having more than one EDT, HSDT or SCSI, the system identifies each one.

If the AUTO START switch is in the ON position, the system bypasses stand-alone mode and autoboots into single-user mode while the console displays the following:

```
Boot (UER AX.XX)
Loading CCCC code (UER XXX)
x-1000 Boot
:Autoboot
: cXdXsXsyst
Arix-OS (UER.XXX) Kernal (UER.XXX) Release (LEU.XXX)
(c) 1989 ARIX Corporation
Node (SYSTEM'S NAME)
real mem = xxxxxxx
maximum process size = XX Mbytes
swap area size = xxxxx disk blocks
Available memory = xxxxxxx

X floating point processor(s)
Is the date Wed Jul 19 1989 (y or n)? (y<cr>)
Do you want to check the file system? (y<cr>)
```

Your system displays information about the file system and when complete, enters single user mode (signified by the # symbol).

## ***DISK TEST (disktest)***

This subsection explains selecting and formatting a drive and running the Read/Write test program. This is not a full description of disktest; it is meant to be used as a procedural method of installing a system. To exit disktest at any time, press the escape (<esc>) key.

### **CAUTION:**

**Formatting a disk drive destroys all of the data on the drive. When installing an ARIX system, or a new operating system, you must format the disk drive(s).**

The disktest program features the ability to verify the status of each disk drive in the ARIX system. Disktest executes user-selected tests, displays and logs disk drive hard and soft errors, displays disk configuration information, and formats disk drives.

Formatting the drives verifies that the disks initialize, and are functioning. Running the Read/Write program verifies the functionality of each drive.

When the user selects a test sequence, disktest displays information about the test, prompts the user for information needed to run the selected test, executes the test, and returns to the disktest main menu at the end of the test sequence.

At the stand-alone prompt (:), enter the following command:

```
: disktest<cr>
```

Disktest starts, and displays the following:

```
Disktest Ver X.X  
enter drive to be tested...
```

Disktest requests the address of the disk tape controller and the address of the physical disk drive. For example, to begin the formatting operation with the system default (controller 0 and drive 0), enter the following:

```
00<cr>
```

If there are additional peripheral storage devices in the system, the address of each device must be entered at the prompt that requests the drive address.

To exit disktest at any time, press the <esc> key.

After entering the drive address, disktest displays the following:

```
initializing data areas...
cXdX: Drive Type(# of megabytes)
XXX(0xXXX) cylinders
XX(0xX) heads
XX(0xXX) sectors/track
XXXXXX(0xXXXXX) sectors/disk
XXXX(0xXXX) bytes/sector
enter <ret> to display menu
```

Press <cr> and disktest displays the following main menu:

```
Disk Diagnostic Menu  Ver X.X
a: change parameters -- existing drive XX start XXX
length XXXXX
b: continuous read
c: continuous write
d: read/write test
e: alter pattern -- existing EB6DB6DB
f: format drive
g: display bad sector list
l: list physical disk information

enter your menu selection -- <esc> to exit test
```

This is the main menu of the disktest program. Any of these options can be chosen.

## Checking and Updating Disk Status

To check or update the current status summary of the disk drive without stopping disktest, press `s` (do not press `<cr>`) and disktest displays the following text:

```
drive XX status
XX compare errors
XX soft disk errors
XX hard disk errors
XX complete passes
cylinder 0xXX
```

The disktest disk drive status reports up to the cylinder that was under test when the `s` command was pressed. Errors accumulate from pass to pass. If 10 errors occur on pass 1 and on pass 2 the same ten errors also occur, disktest displays 20 total errors.

Disktest lists hard and soft errors, as follows:

```
Soft disk error # XXX retcode XXX
cylinder XXX head XXX sector XXX
hard disk error # XXX retcode XXX
cylinder XXX head XXX sector XXX
Write pass XX pattern EB6DB6FA
Read pass XX pattern EB6DB6FA
```

## Disk Drive Formatting

During shipping, numerous factors (head movement, temperature change, vibration) change the original factory format. ARIX requires that all disk drives are reformatted and tested with the Read/Write test (found in this subsection).

The format and test process introduces you to formatting procedures, verification that the drive was not damaged during shipping and that the system and drive communicate.

### CAUTION:

Formatting a disk drive destroys all of the data on the drive. When installing an ARIX system or a new operating system, you must format the disk drive.

### OPTION f, FORMAT DRIVE

Perform the procedures in the previous *DISK TEST* subsection to display the following disktest main menu on the console:

```
Disk Diagnostic Menu  Ver X.X
a: change parameters -- existing drive XX start XXX
length XXXXX
b: continuous read
c: continuous write
d: read/write test
e: alter pattern -- existing EB6DB6DB
f: format drive
g: display bad sector list
l: list physical disk information
    enter your menu selection -- <esc> to exit test
```

Formatting time depends on the size of the drive. For a 170 Mbyte drive, formatting takes approximately 15 minutes. Larger drives require more time.

At the display of the disktest main menu, format the drive, as follows:

1. Press **f** (do not press **<cr>**) and disktest responds with the following:

```
WARNING--FORMATTING WILL DESTROY ALL OF THE DATA ON DISK cXdX !
  cXdX: Drive Type(# of megabytes)
  XXX(0xXXX) cylinders
  XX(0xX) heads
  XX(0xXX) sectors/track
  XXXXXX(0xXXXXXX) sectors/disk
  XXXX(0xXXX) bytes/sector
  ok to format(y/n)?
```

At the "ok to format(y/n)?" prompt, entering **n** (no) will abort the format process and return you to the disktest menu.

2. Enter **y** (yes) and disktest displays the following:

```
reading media defect information..
formatting track 0...
recording the media defect list.
copying XX media defect entries
```

```
formatting cylinder 0xXXXX
```

When formatting is complete, disktest displays the following:

```
rewriting sector 0...
initializing data areas . . .
cXdX : Drive Type (* of megabytes)
XXX(0xXXX) cylinders
XX(0xX) heads
XX(0xXX) sectors/track
XXXXX(0xXXXXXX) sectors/disk
XXXX(0xXXX) bytes/sector
enter <ret> to display menu
```

#### NOTE:

If the disk does not initialize after completing the format procedure, contact your ARIX Representative. (Refer to Appendix A, *Technical Support*.)

3. Press **<cr>** to display the disktest main menu.

Another controller and drive can be formatted by repeating this command sequence.

## Read/Write Test

The Read/Write test verifies the disk drive by writing test patterns to and reading these test patterns from the disk drive. The Read/Write test destroys any data on the disk and can record media defects at the end of the test.

This subsection describes changing disk drive parameters, viewing the disk drive status summary and recording errors incurred during testing. Also refer to the *System Administration Guide* for more information.

### OPTION a, CHANGE PARAMETERS

Change the controller and disk drive address, as follows:

1. Perform the procedures in the previous DISK TEST subsection to display the following disktest main menu on the console:

```
Disk Diagnostic Menu Ver X.X
a: change parameters -- existing drive XX start XXX
length XXXXX
b: continuous read
c: continuous write
d: read/write test
e: alter pattern -- existing EB6DB6DB
f: format drive
g: display bad sector list
l: list physical disk information
```

```
enter your menu selection -- <esc> to exit test
```

2. Select option a and disktest requests:  
enter drive to be tested ...
3. Enter the address of the controller and drive to be tested and disktest requests:  
test all but cylinder 0(y/n) ?
4. Enter y (yes) and disktest responds:  
enter <ret> to display menu
5. Press <cr>, which returns you to the disktest main menu.



**OPTION d, READ/WRITE TEST**

The read/write test verifies the functionality of the disk drive, the drive cable, and the disk tape controller. This test writes a data pattern to the drive, reads the pattern from the drive, and verifies that the disk system is operating by comparing the written data pattern to the data pattern that was read.

Errors are displayed when the data patterns differ, and when hard and soft errors occur. Hard errors are physical bad sectors on the drive. Soft errors are missed or stuck bits, or error correction logic that detects what was written does not match with what was read.

The read/write test consists of 32 different bit test patterns that are written to and read from the disk. One test pass is equal to one of the 32 test patterns. One test pass can take over an hour, depending on the size of the disk drive.

To select the read/write test option, proceed as follows:

1. At the disktest main menu, press **d** and disktest requests:

```
do you wish to compare the read buffer?  y/n
```

2. Press **y** (yes) and disktest requests:

```
do you wish to dump the read buffer on compare error?  
y/n
```

3. Press **n** (no) and disktest displays:

```
write pass 1 pattern EB6DB6DB  
cylinder 0xXX read pass 1 pattern EB6DB6DB  
cylinder 0xXX
```

The cylinder numbers, 0xXX, increment on the console screen. Each drive is tested at the factory and hard errors are recorded on the drive. If testing the drive shows numerous hard errors other than those that were originally recorded, contact your ARIX representative.

## Halting Read/Write Test And Recording Errors

Halt the Read/Write test, as follows:

1. Press the <esc> key and disktest displays the following:

```
drive XX status
XX compare errors
XX soft disk errors
XX hard disk errors
XX complete passes
Do you wish to record the errors that occurred during
this test? y/n
```

2. Record the errors that were found (if any) on the bad sector list: enter y (yes) and disktest displays a list of all errors, as follows:

```
disk error XXX first encounter pass XXX occurrences XXX
soft XXX hard XXX
cylinder XXX head XXX sector XXX pat XXX
retcode XXX
```

Press <cr> if there are more errors than those displayed. At the end of the list of errors, disktest records the errors to the disk and displays the following:

```
x entries added to bad sector list x total entries
enter <ret> to display menu
```

3. Press <cr> to display the disktest main menu.
4. After all disk drives are tested, press the <esc> key to exit the disktest program. The system responds, as follows:

```
x-1000 Boot
:
```

## ***DISK SETUP (dsetup)***

All disk drives should be completely formatted and tested before using the interactive, menu-driven disk setup program, dsetup. This is not a full description of dsetup, but a procedural method to follow when installing a system.

Dsetup configures the disk drive(s) by creating a skip track/spare track table, and requesting information on the number and the size of the logical disks on the physical disk.

"Physical" refers to the non-electrical, actual device (the disk drive unit, the actual memory, the complete tape drive unit). "Logical" refers to virtual electronically selected addresses that define areas used to store and fetch information (logical disks of the disk drive, partitions of the memory, the tape drive information addresses).

Dsetup allows for the creation of several logical disks (slices or partitions) within one physical disk drive.

The terms logical disk, slice and partition, are identical and interchangeable. The operating system treats each logical disk as a separate disk. You must specify the type of a logical disk during disk setup to define the treatment of bad sectors within the disk.

Your system supports up to 2 controllers (0-1), 8 physical disks (0-7), and up to 16 logical disks (0-15) per physical drive. With 8 physical disk drives, your system supports up to 128 logical slices.

### **NOTE:**

You cannot use more than two disk/tape controllers in the 825/800 systems.

To exit dsetup at any time, press q<cr> (quit<cr>) at the dsetup prompt.

The addressing schemes for physical controllers, physical drives and logical slices are described with the device code, cXdXsX, representing which controller, which drive, and which slice to use.

For example, the following is the address for the first physical controller, second physical drive and fifth logical disk:

c0d1s4

Typical slice configurations for the first drive and first controller (c0d0sX) are, as follows:

- s0            The first slice and the root file system.
- s1            The second slice and the swap file system.
- s2            The third slice and the usr file system.
- s3            The fourth slice and the power fail slice.
- s4 to s15    Slices 5 through 16 are the user application and data file systems.

The two major parts to the disk setup procedures in this section are creating and modifying logical disks.

Creating logical disks are the initial operations to configure newly-formatted disk drives (initially, all disk space of a physical drive is allocated to one logical disk drive).

Modifying logical disks refers to subsequent operations on the logical disk structure.

## Logical Disk Types

Logical disks must start on physical disk track boundaries. ARIX file systems may have holes (see below) and the number of usable blocks may be slightly less than the number of requested blocks.

ARIX supports the following disk types:

- FSYS** This type of disk does not require spare sectors to be allocated for the bad blocks. Bad blocks are skipped by `mkfs` and `fsck`. The initial blocks of the file system are spared. The number of blocks guaranteed for this logical disk is the file system size divided by 64. This is also the default size of the inode area.
- SWAP** This is the swap area. It is used as a dynamic work area by the UNIX kernel. It cannot have holes or spares. Any bad sectors in the swap area result in a skipped track. Only one error-free swap area is required per system.
- PWRF** This type of logical disk reserves about 1 Mbyte of disk space for power fail information.
- HOLE** This type of logical disk does not allow spares or skipped tracks. It can be full of bad blocks. Application programs must have provisions for dealing with this type of disk.
- FSPR** This is the default type of file system used by `dsetup`. This type of logical disk does not allow holes. If there are any bad blocks, they are spared by alternate sectors.
- FSKP** This type of logical disk does not allow holes. Bad sectors are spared by skipping the entire track.
- SPLIT** This type of logical disk requires that the initial portion of the disk be error free and the rest can have holes.

These disk types are displayed when the `dsetup` command, "list types" (`l<sp>t<cr>`), is entered at the `dsetup` prompt (`dset up >`).

## Running The *dsetup* Program

Refer to the subsection that follows this subsection, *Dsetup Commands*.

Run *dsetup*, as follows:

1. At the Stand-alone (:) prompt, enter the following command:

```
: dsetup<cr>
```

*Dsetup* identifies itself and requests the following information:

```
Stand-alone dsetup (UER X.XX)
```

```
Enter physical drive unit number to configure:
```

2. The physical drive unit number is a request for the controller and the physical drive address. For controller 0 and physical drive 0, enter the following:

```
00
```

*Dsetup* displays the following:

```
Controller X, drive X selected.
```

```
dsetup>
```

When the *dsetup>* prompt appears, *dsetup* is running in interactive mode and ready for commands. From this point forward, the user selects the commands to be entered.

3. Review the available commands in the dsetup program by entering ?<cr> at the dsetup prompt and dsetup displays the following (variables in [ ] brackets are optional entries):

```

s <*> Select physical drive
c [ <*> ] Select logical disk configuration
  BAD BLOCK COMMANDS
  block* is CCCHHSS(hex) ldisk:block(decimal)
b c <block*> Convert between CCCHHSS <-> ldisk:block number
  b s <block*> Spare a block
  b u <block*> Unspare
  b r <block*> Read a block
  b w <block*> Write a block
  LIST COMMANDS
l b List Bad blocks
l o List Old configuration
l n List New configuration
l t List possible logical disk Types, use with 'm t'
l c List predefined Configurations, use with 'c'
  MODIFY COMMANDS
m s <ld1> <size> [<ld2>] Mod Size of ld1, difference from ld2
m t <ld> <type> Mod Type of ld1 to <type>
m c <ld> <size> Modify clean/inode size to <size>
m p <ld> Modify/reset protection of <ld>
  OTHER COMMANDS
x <ld> <size> Split ld into 2 chunks, expand the ld table
d <ld1> [<ld2>] Delete <ld1>, sectors to <ld2>
q Quit
r <ld1> [<ld2>] Remove <ld1>, as delete except collapse table
u Undo the previous change
w Write the setup to disk (no undo)
dsetup >

```

4. Select the drive configuration. To list the predefined configurations, enter the following:

```
dsetup>l<sp>c<cr> (lowercase L, space, lowercase c, carriage return)
```

Dsetup responds with:

id	name	detail
0	new	RESERVED:1280 leftover disks { FSP:1024 }*
1	medium drive 0	RESERVED:1280 leftover disks { FSP:50000 }* FSP:16000 SWP:16000 FSP:25000 PF:1024 FSP:25000 FSP:10000 NULL:0
2	small drive 0	RESERVED:1280 leftover disks { FSP:25000 }* FSP:16000 SWP:16000 FSP:21000 PF:1024
3	large drive 0	RESERVED:1280 leftover disks { FSP:50000 }* FSP:16000 SWP:16000 FSP:25000 PF:1024 FSP:30000 FSP:30000 FSP:30000
4	medium drive	RESERVED:640 leftover disks { FSP:40000 }* FSP:25000 FSP:25000
5	small drive	RESERVED:640 leftover disks { FSP:25000 }* FSP:25000 FSP:25000
6	large drive	RESERVED:640 leftover disks { FSP:50000 }* FSP:30000 FSP:30000 FSP:30000 FSP:30000
7	sample config	RESERVED:1280 leftover disks { FSP:20000 }* FSP:16000 SWP:16000 FSP:25000 PF:1024
8	sample config	RESERVED:1280 leftover disks { FSP:30000 }* FSP:20000 FSP:20000
9	sample config	RESERVED:1280 leftover disks { FSP:50000 }* FSP:16000 FSP:16000 FSP:20000 PF:1024 FSP:20000 FSP:20000 FSP:20000

dsetup>

The "id" column is the configuration id used in the following step (Step 5), the "name" column is the name of the sample configuration, the "detail" column provides additional information about the configuration.

5. Select a logical disk configuration: enter the configuration command (c) and the digit that corresponds to the desired configuration, as follows:

```
dsetup>c<configuration id><cr>
```

When the configuration command is entered without an id, dsetup displays the following:

```
choosing configuration 1
WARNING, check: ld 7, size changed from XXXXX to XXXXX
dsetup >
```



6. Display the disk configuration, enter the following command:

```
dset up>l<sp>n<cr> (lowercase L, space, lowercase N, carriage return)
```

Dsetup displays the following:

```
XXXXXXXX sectors available
X tracks skipped, X holes, XX spares, XXX skips
ld  type  st   size  clean  start(CCC.HH)  skip  track spare  holes
0   FSPR
1   SWAP
2   FSPR
3   PURF          (DATA is displayed here)
4   FSPR
5   FSPR
7   FSPR
WARNING, check: ld 7, size changed from XXXXX to XXXXX
dsetup >
```

Use the modify commands to customize your disk configuration.

7. Enter the following to write the configuration to the disk:

```
dset up>w<cr>
```

Dsetup responds and displays the following:

```
controller X, drive X selected.
dsetup >
```

8. When the disk configuration is complete, quit dsetup; enter q<cr> at the dsetup prompt to quit. Dsetup responds, as follows:

```
(0) returned by exit
x-1000 Boot
:
```

9. If ldsa has not been executed return to the subsection *Transferring Bootimage to Disk* and execute the ldsa program.

If loading software, refer to the corresponding *ARIX Release Notes* or the *ARIX Operating System Manual*.

To enter single-user state, press <cr> at the stand-alone prompt (:), and the console displays the following:

```
:cXdXsXsyst
SYST/xxxx: ARETE vX.x X-X M68020
(c) 1987 ARIX Systems Corporation
real mem = xxxxxx
avail mem = xxxxxx
x processor system
x floating point processor(s)
INIT: SINGLE USER MODE
*
```

## *dsetup* Commands

The *dsetup* command structure allows the user to locate, view, create and/or modify logical disks anywhere in the system. This subsection explains the commands that can be used once the user is in *dsetup*. Entering a question mark (?) at the *dsetup* prompt, *dsetup* displays a list of the available commands with a short description of each command.

To specify a different physical disk drive after one has already been chosen, use the following syntax:

```
dsetup>s<sp>XYY<cr>
```

Where: X is the single-digit controller number

YY is the single-, or double-digit disk drive number

The list of commands for old and new configurations is meaningless during the initial disk setup operation; neither one exists yet. The following command lists the types of logical disks that are available:

```
dsetup>l<sp>t<cr> (lowercase L, space, lowercase T, carriage return)
```

*Dsetup* displays the following:

```
1  FSYS
2  SWAP
3  PWRF
4  HOLE
5  FSPR
6  FSKP
7  SPLIT
dsetup >
```

When you select a drive, you can view the existing configuration for that drive with the list command. For example, enter the following to list the existing (old) logical disk configuration for that physical drive:

```
l<sp>o<cr> (lowercase L, space, lowercase O)
```

*Dsetup* displays the following (all disk space is allocated to one logical disk initially):

```
XXXXXXXX sectors available
X tracks skipped, X holes, X spares, X skips
ld type  st  size  clean  start  skip  track  spare  holes
0  FSYS   XXXX
dsetup >
```

If this is the first time you are executing *dsetup*, the above command is invalid since there is no "old" configuration. After the first configuration, you can use the List Old command to configure all your drives.

All dsetup commands to create or modify disk configurations operate in main memory.

The terminology used in the configuration listing is, as follows:

ld	Logical disk number, if present, -1 indicates the reserved area used for the boot image program and configuration data.
type	Logical disk type.
st	Logical disk status (P if it is protected).
size	Size of the logical disk in 1024 byte blocks.
clean	Available inode area of the logical disk.
starting block #	Start of the logical disk (within the physical disk).
skip	Number of blocks skipped with FSKP devices, or number of spare blocks allocated with FSPR devices.
track	Number of bad tracks skipped.
spare	Number of bad blocks mapped to spare blocks.
holes	Number of bad blocks not skipped or spared.

The contents of the disk are lost when modifying an existing disk configuration. When you use the dsetup write command (w<cr>) to save the disk configuration, dsetup automatically write-protects the logical disk configuration.

To remove the protection prior to changing the logical disk configuration, you must use the dsetup modify protection command (m<sp>p<cr>). Each logical disk protection is removed individually.

For operating systems prior to ARIX 4.0, the size of unprotected logical disks may be affected by logical disks that are protected. For ARIX 4.0 and newer operating systems, protection must be removed from all of the logical disks before any modifications can be performed.

The logical disk structure subdivides the physical disk into a user-specified number of separate areas. The first logical disk (0) is at the beginning of the physical disk boundary, and the highest numbered logical disk (15) is at the end of the last physical disk boundary.

For more information, refer to the *Power-up and Initialization* section in the *ARIX Operating System Manual*.

## **MULTI-USER STATE**

This subsection describes the process to enter multi-user state: entering the initialization command, correcting the date and checking the file systems.

Begin multi-user state from single-user state, as follows:

1. At the single-user prompt (**#**), enter the following command to start multi-user initialization:

**#init 2**

The console displays the following:

```
INIT: New run level: 2
Is the date xxx xxx x xx:xx:xx xxx 19xx correct? (y or n)
```

2. If the date is correct, enter a **y** (yes) and continue to step 3. If the date is incorrect, proceed as follows:

- a. Enter a **n<cr>** and the console displays the following:

Enter the correct date

- b. Enter the correct date using the format, **MMddhhmmyy**, where the data fields are, as follows:

MM is the number of the month (01-12)

dd is the number of the day (01-31)

hh is the hour (24 hour time)

mm is the minute (01-59)

yy is the last two digits of the year

All fields must be two digit numbers. Enter today's date using the date format, and the console displays the following:

```
Is the date xxx xxx x xx:xx:xx xxx 19xx correct? (y or n)
```

If the date is still incorrect, enter **n<cr>** and repeat Step 2.

3. Enter a **y<cr>** and the console displays the following:

Do you want to check the file systems? (y or n)

4. Enter a `y<cr>` to check the file systems and the console displays the following:

```
/dev/dsk/c0d0s0
```

```
File System: Volume:
```

```
** Phase 1 - Check Blocks and Sizes
```

```
** Phase 2 - Check Pathnames
```

```
** Phase 3 - Check Connectivity
```

```
** Phase 4 - Check Reference Counts
```

```
** Phase 5 - Check Free List
```

```
xxx files xxxx blocks XXXXX free
```

```
/dev/dsk/c0d0s2
```

```
File System: Volume:
```

```
** Phase 1 - Check Blocks and Sizes
```

```
** Phase 2 - Check Pathnames
```

```
** Phase 3 - Check Connectivity
```

```
** Phase 4 - Check Reference Counts
```

```
** Phase 5 - Check Free List
```

```
xxx files xxxx blocks XXXXX free
```

```
.
```

```
.
```

```
.
```

```
console login:
```

Refer to the `fsck(1m)` manual page in the *ARIX System V Administrator's Manual* for more information.

The system is fully initialized, loaded and ready to operate in a multi-user state. Refer to the *ARIX System V Administrator's Guide* and the *ARIX System V Administrator's Reference Manual* for more information on installation procedures for site dependent files and/or software for the system.

## SYSTEM SHUTDOWN

Whenever the system must be shut down, such as for backups or a re-boot, the `/etc/shutdown` program is executed from the system console. The shutdown procedure performs an orderly shut down: flushes all buffers, terminates all processes and brings the system to the single-user state.

The amount of grace period between sending a warning message out and actually shutting down can be specified.

The command and option are: `shutdown -g[number of seconds]`.

For example, entering `shutdown -g300<cr>` requests a 5-minute (300 seconds/60 seconds = 5 minutes) delay and gives users the time to end and save their processes before the shutdown. Without the option, Shutdown gives a default grace period of 60 seconds.

Initiate a shutdown, as follows:

1. Login to the system console.
2. Change to the root (`/`) directory:

```
*cd /
```

3. Enter the following command:

```
*shutdown
```

```
Shutdown started.  Wed Jul 19 12:54:45 PDT 1989
Broadcast Message from root(console) on (SYSTEM) Wed Jul 19 12:54:46
Log off now or risk your files being damaged
```

Not specifying a grace period, the default grace period is used. This gives all system users 60 seconds to write and close their files before system processes are killed. The system responds, as follows:

```
Do you want to continue (y or n)?
```

To exit the shutdown program, enter `n` and the system notifies all users that the shutdown was a false alarm and is being aborted.

4. Continue the shutdown program: enter `y` and the system displays the following:

The system is coming down. Please wait.

System services are being stopped now.

Stopping LP scheduler

Line printer scheduler stopped

Error logging stopped.

Process accounting stopped.

All currently running processes will not be killed.

\*\*\*\* SYSCON CHANGED TO /dev/console \*\*\*\*

Wait for INIT: SINGLE USER MODE before halting

\*

INIT: New run level: S

INIT: SINGLE USER MODE

\*

#### NOTE:

If any changes are made to files from single-user mode (\*), you must enter the synchronize (`sync`) command so that all changes are flushed (written) from main memory back to disk (this process is automatic in multi-user state).

From single-user state, you can:

- Enter monitor mode (`>`): turn the key at the front of the system to the RESET position.
- Enter multi-user state: at the prompt (\*) enter the initialize command (`init 2<cr>`).
- Remove power from the system (refer to the following section, *Power Removal*).



## POWER REMOVAL

Before removing power from the system, refer to the previous section, *System Shutdown*).

When you move the keyswitch at the front of the system to the OFF position, the system is put into a simulated power failure condition. The system automatically begins a sequence to shutdown gracefully. If this sequence is interrupted or if the key is returned to the ON position, damage to the file systems may occur.

### CAUTION:

The power removal sequence must be fully completed before returning the key to the ON position. The disks are synchronized in this sequence to avoid damage to the file systems.

Remove power to the system, as follows:

1. At the front of the system, turn the key to the OFF position. The console displays the following:

#

```
Shutdown started.  Wed Jul 19 12:54:45 PDT 1989
Broadcast Message from root(console) on (SYSTEM) Wed Jul 19 12:54:46
Log off now or risk your files being damaged
```

After two minutes, the operating system synchronizes the disks and displays the message:

```
The system is coming down.  Please wait.
System services are being stopped now.
Stopping LP scheduler
Line printer scheduler stopped
Error logging stopped.
Process accounting stopped.
All currently running processes will now be killed.

Wait for INIT: SINGLE USER MODE before halting
#
INIT: Shutting power
```

The system removes internal power and the green indicator (facing the front of the system, the LED to your right) goes out while the yellow/amber LED remains on (signifying that internal power is off and AC power is still supplied).

2. From the rear of the system, move the main power breaker to the OFF (or 0) position.

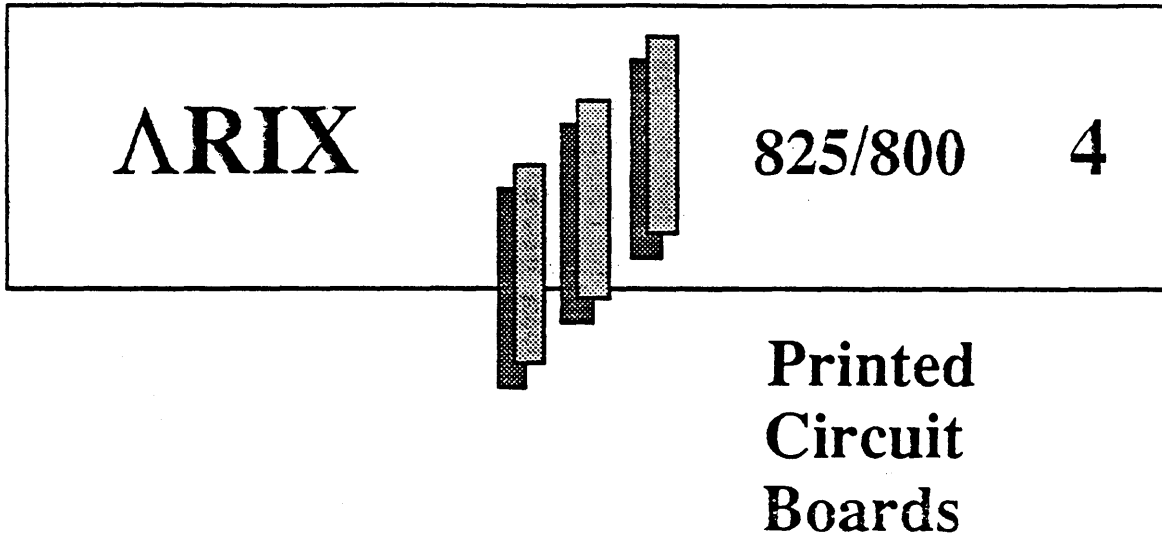

This section describes installing and removing interface and logic boards. The two groups of system boards are the intelligent logic and interface boards. The system support boards are the system backplane and power control board.

The ARIX boards are, as follows:

- **Logic boards** are the processors of the system, and include the Application Processors (APs: CPU32, CPU32/25 MHz), memory (2, 4, 8, 16, 32 Mbyte RAM), the Data Processors (DPs: HSDT, EDT and SCSI), the Intelligent Communication Processors (ICPs: GC8, EGC and GC16), and the Multibus Adapter Card (MAC).
- **Interface boards** provide the connection from the logic boards to the peripherals, and/or communication devices. These include the DPs (HSDT, EDT and SCSI), and the ICPs (GC8, EGC, and GC16)
- The **power control board** supplies and regulates power to all system components. From the rear of the system, the power control board resides in the left rear of the card cage, behind the external tape/disk cable connector panel.
- The **system backplane** supplies all system boards with control, data, and address buses. The backplane supplies power (from the power control board) to the system boards, and provides the necessary bus terminations.

The *Site Preparation Manual for the Model 825/800* also explains logic and interface board connections and support requirements.

The logic boards install in the front and the interface boards install in the rear of the card cage. Interface boards attach directly to the logic boards, and not through the backplane. The backplane resides in the center of the system. All logic boards install into the backplane.

Figure 4-1 shows the placement of an I/O logic and its respective interface board in a system, with details of the system. Table 4-1 shows the relationships between the Data Processor (DP) and Intelligent Communication Processor (ICP) boards. Tables 4-2 and 4-3 show the support combinations of interface boards to logic boards.

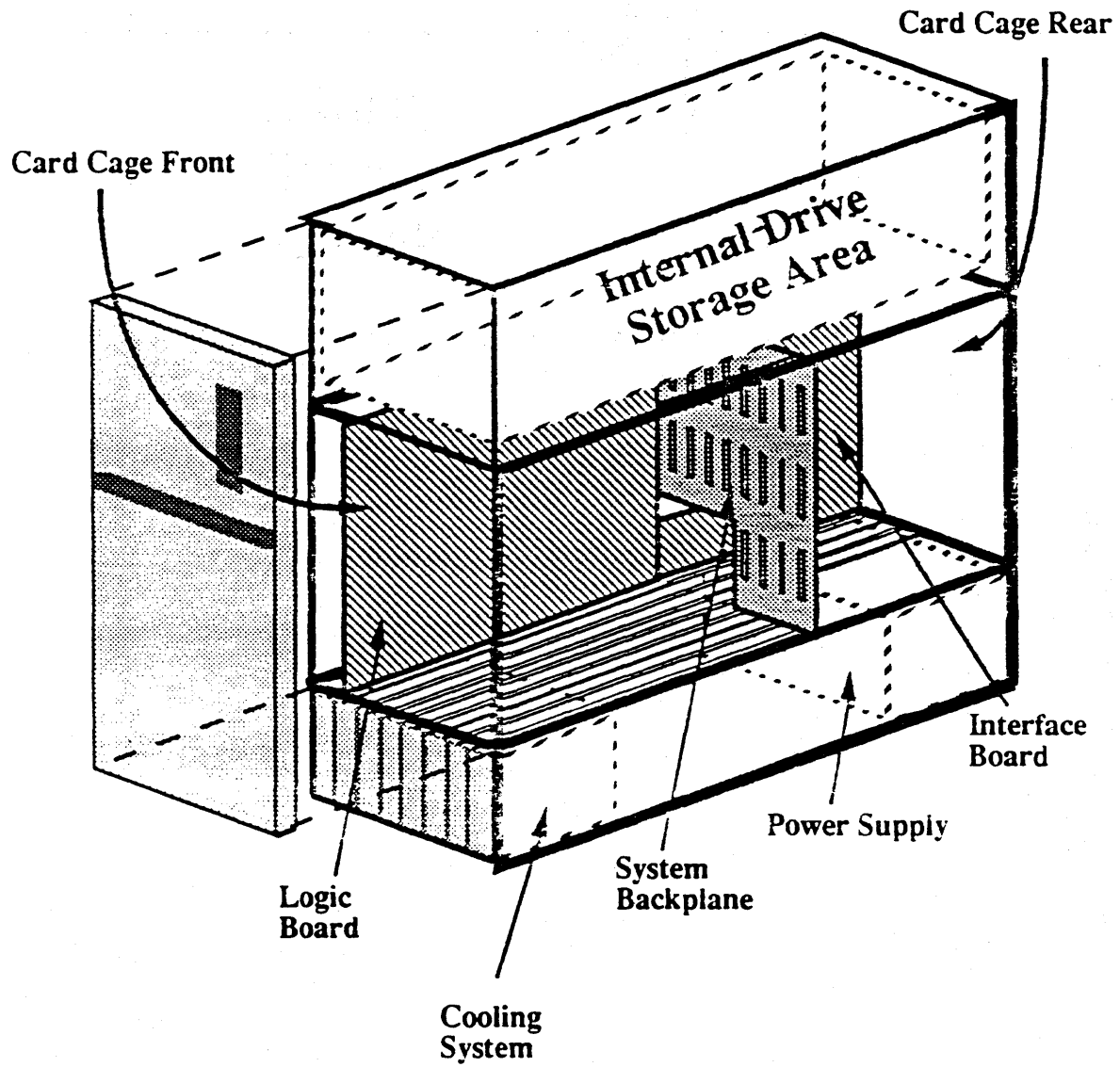

Figure 4-1. Logic and Interface Boards

Table 4-1. I/O Family Related Boards

Family	I/O Related Boards
Database Processors (DP):	Enhanced Disk Tape Controller (EDT) High Speed Disk Tape Controller (HSDT) Small Computer Systems Interface (SCSI)
Intelligent Communication Processors (ICP):	General Communications-8 (GC8) * Enhanced General Communications (EGC) General Communications-16 (GC16)

\* ARIX supports, but no longer manufactures GC8 boards.

Table 4-2. DP/ICP Device Support

Logic Boards	Interface Boards	Device Support
DP: HSDT, EDT	DP 9-track	9-track Tape Drive Two disk drives
DP: HSDT, EDT, SCSI	DP-cartridge	Cartridge Tape Fourteen disk drives
ICP: GC/EGC/GC16	ICP: GC/EGC/GC16	Terminals, Modems, Printers

Table 4-3. DP Logic Board Device Support

DP Logic Board	Supports
HSDT 9-Track	One 9-track tape drive and up to two disk drives with data transfer speeds of up to 1.8 Mbytes/second
HSDT Cartridge	One cartridge tape drive and up to four disk drives with data transfer speeds up to 1.8 Mbytes/second.
EDT	Depending on the interface board selected, the supported device group is either:  (1) one cartridge tape drive and up to four disk drives, or (2) one 9-track drive and up to two disk drives.  The disk drives provide data transfer rates of up to 2.4 Mbytes/second
SCSI	One cartridge tape drive and up to fourteen disk drives

All DP, ICP, Multibus Adapter Card (MAC) and VMEbus Adapter Card (VAC) boards support I/O devices. ARIX Central Processing Unit (CPU32) are based on the 32-bit Motorola 68020, running at clock speeds of either 12.5 MHz (CPU32) or 25 MHz (CPU32/25).

Older systems used 68000-based processor boards (CPU16). These models can operate with a mixture of CPU16 and CPU32 boards. However, you cannot mix CPU32s and CPU32/25s.

Table 4-4 describes the card cage slot assignments. The Master CPU, slave CPUs, and memory boards install in slots J03 through J05. The DMC board installs in slot J06. The DP and ICP logic and their related interface boards install in I/O slots J07 through J12.

**Table 4-4. Card Cage Slot Assignments**

Slot	Board Assignments	
Number	Logic	Interface
J03	Master CPU	
J04	Slave CPU,	none
J05	MEMORY	
J06	DMC4/2 or DMC4	none
J07	EDT, HSDT,	
J08	SCSI	IDP
J09	and/or	or
J10	GC8/EGC/GC16	ICP
J11	and/or	
J12	MAC and/or VAC	

An ARIX system with a DMC4/2 supports a maximum of two DMA channels and restricts the system to a maximum of two EDT, HSDT, SCSI, MAC or VAC boards.

An ARIX system with a DMC4 supports a maximum of four DMA channels and provides up to four EDT, HSDT, SCSI, MAC or VAC boards.

## ***CPU32 MASTER/SLAVE SELECTION***

On the front of the CPU32 board (12.5 MHz, or 25 MHz) is a toggle switch that controls the configuration of "master" or "slave." (Refer to Figure 4-2, *CPU32 Master/Slave Switch*.)

### **NOTE:**

If a system contains more than one CPU32 board, configure only one as a master. If you install a new CPU board as master, you must configure the previous master as a slave. The console terminal connects to the master CPU only.

To configure the CPU board, look at the front of the board. Beneath the row of different colored status LEDs, is a two-position toggle switch.

Using a non-metal pointed object, carefully move the toggle switch to one of the following positions:

- Master selection: move the toggle switch to the down (MSTR) position.
- Slave selection: move the toggle switch to the up (SLV) position.

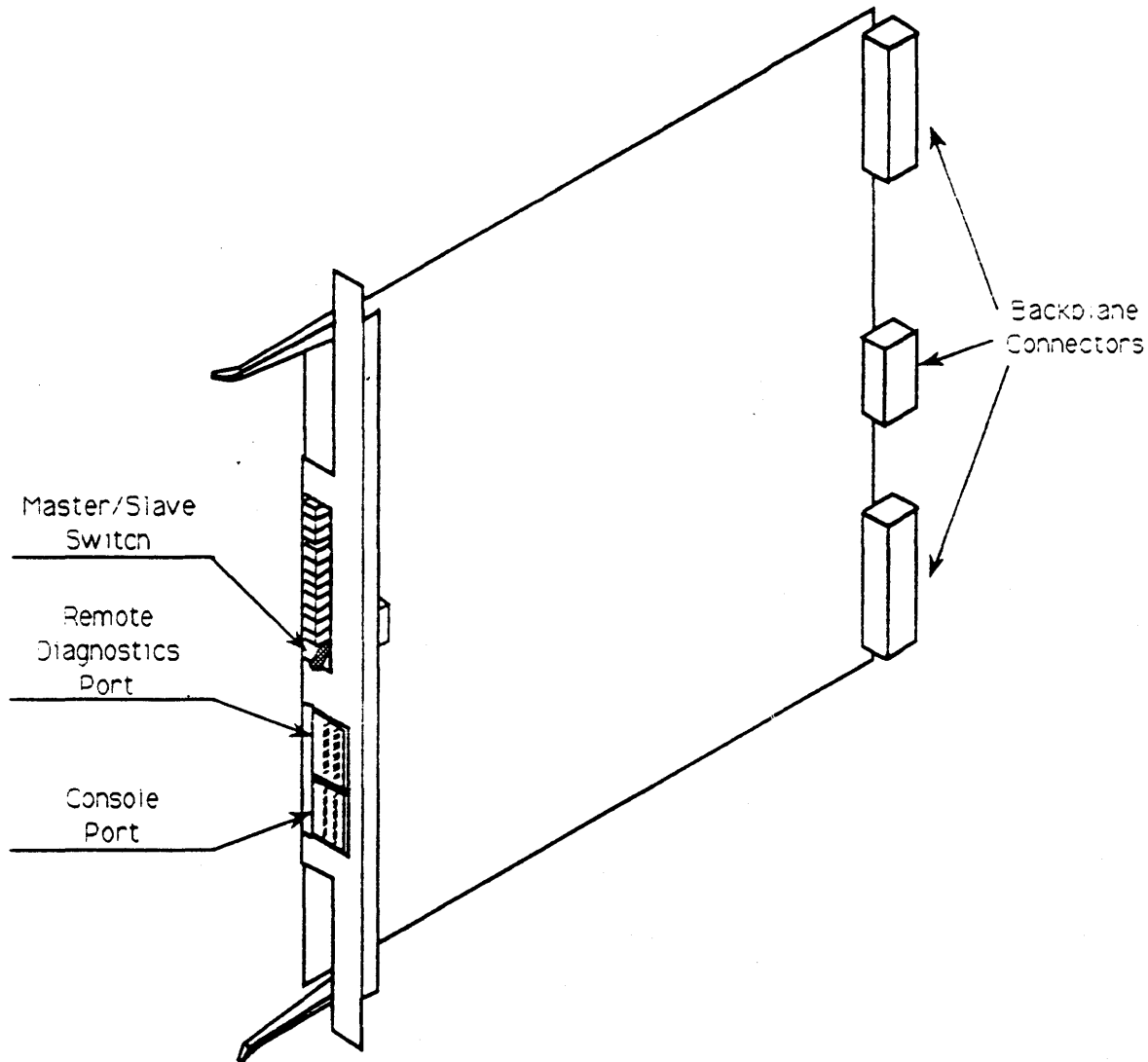

Figure 4-2. CPU Master/Slave Switch

## PC BOARD REMOVAL AND INSTALLATION

The subsections that follow describe the removal and installation procedures for the logic and interface boards.

### CAUTION:

**Before removing or installing any circuit boards or components, do the following:**

- Remove the system power. (Refer to Power Removal in Section 3, *System Startup and Shutdown*).
- Use a static strap to ground yourself.

Replacement boards install in the same board slot as the original board. Remove only one board at a time so that finding the identical board slot for the replacement board is not a problem.

### CAUTION:

**Do not change the toggle switch settings on any board, unless specifically directed to do so. The toggle switches are preset for proper board operation.**

Handle only the edges of the board to avoid damaging the components and/or connectors of the circuit boards.

## Logic Board Removal and Installation

Prior to installing an interface or logic board, visually check that all socketed ICs are securely seated, and all cables are secure.

The CPU, Memory, and DMC boards do not have interface boards. The DP and ICP logic boards require an interface board. Some ICP and DP boards require setting or verifying switches, ICs, and/or jumpers prior to installation.

If the logic board has an accompanying interface board that is not yet installed, install the interface board before proceeding (refer to the following section, *Interface Board Removal and Installation*). This ensures that there is a good electrical connection between the logic board and the interface board.



## LOGIC BOARD REMOVAL

Replace one board at a time. Prior to removing any system component, the system must be shutdown and power removed (refer to Section 3, *System Startup and Shutdown*).

From the front of the system, remove the logic board, as follows:

1. Remove the front system cover: pull out on the edges of until the cover pops off.
2. Remove the metal plate that covers the PC boards: remove the screws that secure the plate to the chassis. Save the screws for the installation procedure.
3. Use a medium (#2) phillips screwdriver and remove the screws from the top and bottom flanges of the front metal edge of the board. Save the screws for the installation procedure.
4. Label and remove any cables attached to the board .
5. Eject the board: gently pull outward alternating between the top and bottom white plastic ejector tabs, this unseats the board from the backplane connectors.
6. Gently slide the board out of the card cage while holding the board's edges.
7. Record the board type, serial number, and slot number of the logic board.
8. Put the board in a plastic anti-static bag to protect the components from electrical damage.
9. Place the board (wrapped in the anti-static bag) in an upright position if possible. Do not place the board in a humid environment.
10. Repeat Steps 3 through 9 for each board to be removed.

### NOTE:

To aid in system cooling, all empty board slots must be covered with slot cover plates before power-up. Call an ARIX Representative if additional slot cover plates are needed.

11. If all the boards originally removed at this time are not being replaced, install the slot cover plate(s) of any missing board(s).
12. Replace the system front cover: align the studs of the cover with the holes in the front chassis and press the cover until it pops on.

## LOGIC BOARD INSTALLATION

Install one board at a time. Prior to installing any system component, the system must be shut down and power removed (refer to Section 3, *System Startup and Shutdown*).

### CAUTION:

**Connecting the wrong combination of interface boards and logic boards will result in damage to the boards.**

If installing a Multibus Adapter Card (MAC) or VMEbus Adapter Card (VAC), perform the subassembly instructions given in the *Multibus Adapter Card Setup*, or in *VMEbus Adapter Card Setup* later in this section, respectively.

If installing a CPU32 logic board, verify that it is configured as a "master" or "slave". If it has not been configured, perform the procedures in the previous subsection, *CPU32 Master/Slave Selection*.

From the front of the system, install the logic board, as follows:

1. Remove the front system cover: pull out on its edges until the cover pops off.
2. Remove the slot cover plate with a phillips screwdriver. Save the slot cover plate and screws.

### NOTE:

If the system's CPU configuration has changed, mixed-mode or pure versions of the operating system and/or applications software must be used as appropriate. Pure configurations are those with CPU32 (12.5 MHz) or CPU32/25 (25 MHz) boards only. Any configuration that includes a CPU16 board is a considered a mixed configuration. The CPU configuration dictates the type of operating system that can be used.

3. Remove the board from its anti-static bag: hold the circuit board by its front metal edge and withdraw the board from the anti-static bag.
4. Inspect the boards connections to ensure that there is no foreign matter in the connections.

**NOTE:**

Do not force the board into the backplane. If there is any interference, withdraw the board and check its backplane connections.

5. Holding the board only by its edges, guide it into the upper and lower tracks of the card cage, until the board is within one inch of being seated in the backplane. The component side of the board must be to the right.
6. Gently push the board into the card cage and allow for the slots of the plastic ejector tabs to connect to the upper and lower parts of the card cage.
7. Push gently on the plastic tabs, alternating between top and bottom to make a rocking action that will seat the board into the connectors. If there is interference, remove the board and check the connectors.
8. Secure the board in the card cage by moving the plastic ejector tabs inward to their closed positions.
9. Using a phillips screwdriver, replace the top and bottom screws in the front metal edge of the board to fasten it to the system frame.
10. If installing a new master CPU, the console cable must be connected. Locate and install the console cable to the corresponding connector of the new master CPU (the bottom connector on the front of the board). The red edge of the cable (pin 1) must be down for correct pin to pin alignment. If installing a remote console modem, refer to the procedures in section 5, *CPU Remote Diagnostic Console*.
11. If a new Multibus Adapter Card (MAC) was installed, ensure that all the appropriate cabling was also installed.
12. If all the boards originally removed at this time are not being replaced, install the slot cover plate(s) of any missing board(s).
13. Repeat steps 2 through 12 for each logic board installation.
14. Replace the system front cover: align the studs of the cover with the holes in the front chassis and press the cover until it pops on.

**CAUTION:**

**Before attempting to power-up the system in a reduced configuration, check with your System Administrator to be sure that all the necessary parameters are properly set. If the system does not have an adequate complement of boards for proper system operation, do not power up the system.**

If the considerations contained in the preceding steps have been satisfied, the system may be powered up. (Refer to Section 3, *System Startup and Shutdown*).

## ***Interface Board Removal And Installation***

The interface boards install in the back of the card cage in slots J07 through J12. Interface boards install only in slots that have a corresponding type of logic board, as described earlier in this section.

### ***INTERFACE BOARD REMOVAL***

Remove one interface board at a time. Prior to removing any system component, the system must be shutdown and power removed (refer to Section 3, *System Startup and Shutdown*).

From the rear of the system, remove the interface board, as follows:

1. Locate and record the board type, serial number, and slot number prior to removing the interface board.
2. Label and remove the cables from the connectors on the interface board.
3. Unscrew the top and bottom thumbscrews of the board to be removed.
4. Gently remove the board: hold the board by its edges and pull outward until the interface board unseats from its corresponding logic board.
5. Gently slide the board out of the card cage while holding the board by its edges.
6. Place the interface board in a plastic anti-static bag to protect the components from electrical damage.
7. Place the interface board (wrapped in the anti-static bag) in an upright position. Do not place the board in a humid environment.

8. If all the board originally removed at this time is not being replaced, install a slot cover plate.
9. Repeat steps 1 through 7 for each interface board being removed.

If all the boards originally removed at this time are not being replaced, install the slot cover plate(s) of any missing board(s).

### **INTERFACE BOARD INSTALLATION**

The installation of an interface board consists of removal of the slot cover plate, withdrawal of the corresponding logic board part way out of the card cage, confirming the configuration of the interface board, and installing the interface board into the card cage, followed by re-installing the corresponding logic board.

#### **CAUTION:**

**Connecting the wrong combination of interface boards and logic boards will result in damage to the boards.**

If you are installing an ICP (GC, EGC, or GC16) interface board, additional setup may be required. If installing DCE or DTE devices, you may have to relocate port IC groups on the interface board. Prior to installing this type of board refer to the next subsection, *GC/EGC/GC16 Interface Board Setup*.

From the rear of the system, install the interface board, as follows:

1. Verify that the interface board is being installed in the same slot as the related logic board.
2. Remove the slot cover plate: loosen the screws (on the top and bottom of the plate) that fasten the slot cover plate to the frame. Save the screws and the slot cover plate.
3. From the front of the system, a partial removal of the corresponding logic board is required. Partially remove the logic board, as follows:
  - a. Remove the top and bottom screws that secure the corresponding logic board.
  - b. Eject the board by alternately pulling outward on the top and bottom white plastic ejector tabs.
  - c. Hold the logic board by its edges and slide the board out one inch.
4. Hold the interface board only by its front metal edge and remove the board from its anti-static bag.

5. Inspect the interface board and ensure that there is no foreign matter in the connectors.
6. Hold the interface board only by its edges and guide it into the upper and lower tracks of the card cage. The components of the interface board must face to the right.
7. Hold the interface board by its edges only and slide the interface board into the card cage slot until it is within one inch of being seated in the backplane.

**NOTE:**

Do not force the board into the backplane. If there is any interference, withdraw the board and check its backplane connections.

8. Gently push the interface board into the frame. If there is interference, remove the interface board and check it's connectors.
9. Secure the board to the card cage by tightening the thumb screws at the top and the bottom of the interface board with a flat screwdriver.
10. Connect the free end(s) of the cable(s) to the proper connector(s) on the interface board.
11. Using a straight screwdriver, secure the cable cover to the exposed metal edge of the interface board with the cable cover screws.
12. From the front of the system, re-install the logic board, as follows:
  - a. Gently push the board into the card cage and allow for the slots of the plastic ejector tabs to connect to the upper and lower parts of the card cage.
  - b. Push gently on the plastic tabs, alternating between top and bottom to make a rocking action that will seat the board in to the connectors. If there is any interference, remove the board and check the connectors.
  - c. Secure the board in the card cage: move the plastic ejector tabs inward to their closed positions.
  - d. Using a phillips screwdriver, replace the top and bottom screws in the front metal edge of the board to fasten it to the system frame.

If installing a replacement interface board, attach the free cables to the new board exactly the same way they were on the original board, or as labels on the cables indicate.

If unsure of the proper cable/interface connector locations, call an ARIX Representative for assistance. Previous steps were taken to label each cable prior to removing them from the board. Pin 1 is marked by the red line and must be in the up position.

## GC/EGC/GC16 INTERFACE BOARD SETUP

The GC/EGC/GC16 interface board provides serial data I/O ports in synchronous and asynchronous format, depending on the board configuration.

The interface setup consists of determining which communication configuration to use and relocating the IC port group that configures the ports of the GC/EGC/GC16 interface board.

The GC/EGC 8-port and the GC16 sixteen-port interface boards can be configured to either Data Communications Equipment (DCE), or Data Terminal Equipment (DTE) by relocating a port IC group.

### CAUTION:

When placing an IC on the board, align the IC carefully over the IC socket and verify that each leg is aligned with its socket before pressing the IC in place. Be careful, if a leg of the IC is bent out of position, the port will fail to work.

Figure 4-3, GC/EGC Interface Board, shows the location of the IC groups that configure the ports to either Modem or Terminal. Table 4-5, GC/EGC DCE/DTE Port Configuration shows which IC group(s) to move to configure the port(s).

Figure 4-4, GC16 Interface Board, shows the location of the IC groups that configure the ports to either DTE or DCE. Table 4-6, GC16 DCE/DTE Port Configuration, shows which IC group(s) to relocate to configure the port(s).

All GC/EGC/GC16 interface boards are configured at the factory for terminal or DCE communication, and are shipped ready to accommodate a terminal type attachment (including serial printers).

Refer to the figure that applies to the board you are configuring. Notice the IC coordinates: the letters down the side of the board, and the numbers across the top of the board. These IC coordinates are stamped on the board and are used in the tables for ease of identifying and relocating the IC port group(s).

Note that there are two types of ICs used in configuring the ports: 1488 or 1489. The 1488s install only in odd-numbered locations. The 1489s install only in even-numbered locations. (Refer to the tables showing port configurations.)

The following subsections describe changing the port group ICs for the GC/EGC and the GC16 boards.

## GC/EGC DCE/DTE Port Configuration

Each serial port on the ARIX system is configured at the factory as a DTE (terminal type) and shipped ready to accommodate a terminal type attachment (including serial printers).

To communicate with modems, which are classified as Data Communications Equipment (DCE), the GC/EGC interface board is configured with the driver ICs in the "Modem" (DTE) locations. To communicate with terminals, which are classified as Data Terminal Equipment (DTE), the driver ICs are installed in the "Terminal" (DCE) locations.

The GC/EGC interface board configuration is for which device is connecting to the GC/EGC interface board ("Terminal" to support DTEs, or "Modem" to support DCE).

Look at the component side of the GC/EGC interface board (refer to Figure 4-3, *GC/EGC Interface Board*). At the bottom of the board, each synchronous data port, 0 and 1, consists of four ICs per port group. Above synchronous ports 0 and 1, are the asynchronous ports, 2 through 7, consisting of two ICs per port group. Determine which ports are to be configured, and relocate the IC port group, one IC at a time, as shown in Table 4-5.

**Table 4-5. GC/EGC DCE/DTE Port Configuration**

Port Number	Modem (DTE)	Terminal (DCE)	IC Code
Asynchronous Port 7 (P9)	2A	4A	1489
	3A	5A	1488
Asynchronous Port 6 (P8)	2B	4B	1489
	3B	5B	1488
Asynchronous Port 5 (P7)	2C	4C	1489
	3C	5C	1488
Asynchronous Port 4 (P6)	2D	4D	1489
	3D	5D	1488
Asynchronous Port 3 (P5)	2E	4E	1489
	3E	5E	1488
Asynchronous Port 2 (P4)	2F	4F	1489
	3F	5F	1488
Synchronous or Asynchronous Port 1 (P3)	2G	4G	1489
	3G	5G	1488
Asynchronous Port 1 (P3)	2H	4H	1489
	3H	5H	1488
Synchronous or Asynchronous Port 0 (P2)	2J	4J	1489
	3J	5J	1488
Asynchronous Port 0 (P2)	2K	4K	1489
	3K	5K	1488



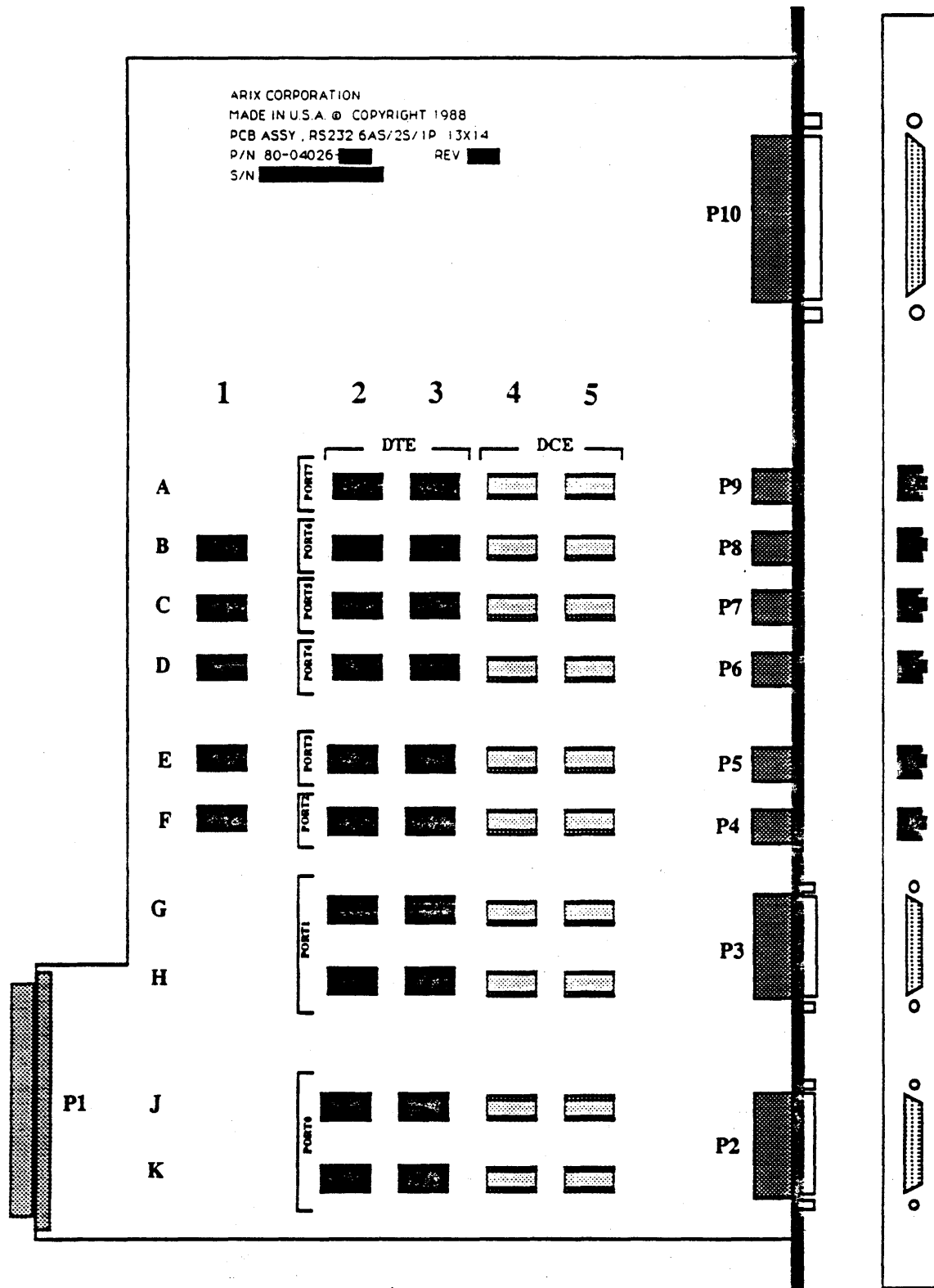

Figure 4-3. GC/EGC Interface Board

## GC16 DCE/DTE Port Configuration

To communicate with modems, which are DCE, the GC16 interface board (P/N 80-2206-XX) is configured with the driver ICs in the DTE locations. To communicate with terminals, which are DTE, the GC16 interface board must be configured with the driver ICs in the DCE IC locations. This configuration is for the device the GC16 interface board represents (DCE to support DTE, or DTE to support DCE).

**Table 4-6. GC16 DCE/DTE Port Configuration**

Port Number	DTE	DCE	IC Code
Asynchronous Port 15	2A	4A	1489
	3A	5A	1488
Asynchronous Port 14	2B	4B	1489
	3B	5B	1488
Asynchronous Port 13	2C	4C	1489
	3C	5C	1488
Asynchronous Port 12	2D	4D	1489
	3D	5D	1488
Asynchronous Port 11	2E	4E	1489
	3E	5E	1488
Asynchronous Port 10	2F	4F	1489
	3F	5F	1488
Asynchronous Port 9	2G	4G	1489
	3G	5G	1488
Asynchronous Port 8	2H	4H	1489
	3H	5H	1488
Asynchronous Port 7	2J	4J	1489
	3J	5J	1488
Asynchronous Port 6	2K	4K	1489
	3K	5K	1488
Asynchronous Port 5	2L	4L	1489
	3L	5L	1488
Asynchronous Port 4	2M	4M	1489
	3M	5M	1488
Asynchronous Port 3	2N	4N	1489
	3N	5N	1488
Asynchronous Port 2	2P	4P	1489
	3P	5P	1488
Asynchronous Port 1	2R	4R	1489
	3R	5R	1488
Asynchronous Port 0	2S	4S	1489
	3S	5S	1488

Look at the component side of the GC16 interface board (refer to Figure 4-4, *GC16 Interface Board*). Determine which ports are to be configured, and relocate each IC port group, one IC at a time (refer to Table 4-6, *GC16 DCE/DTE Port Configuration*).

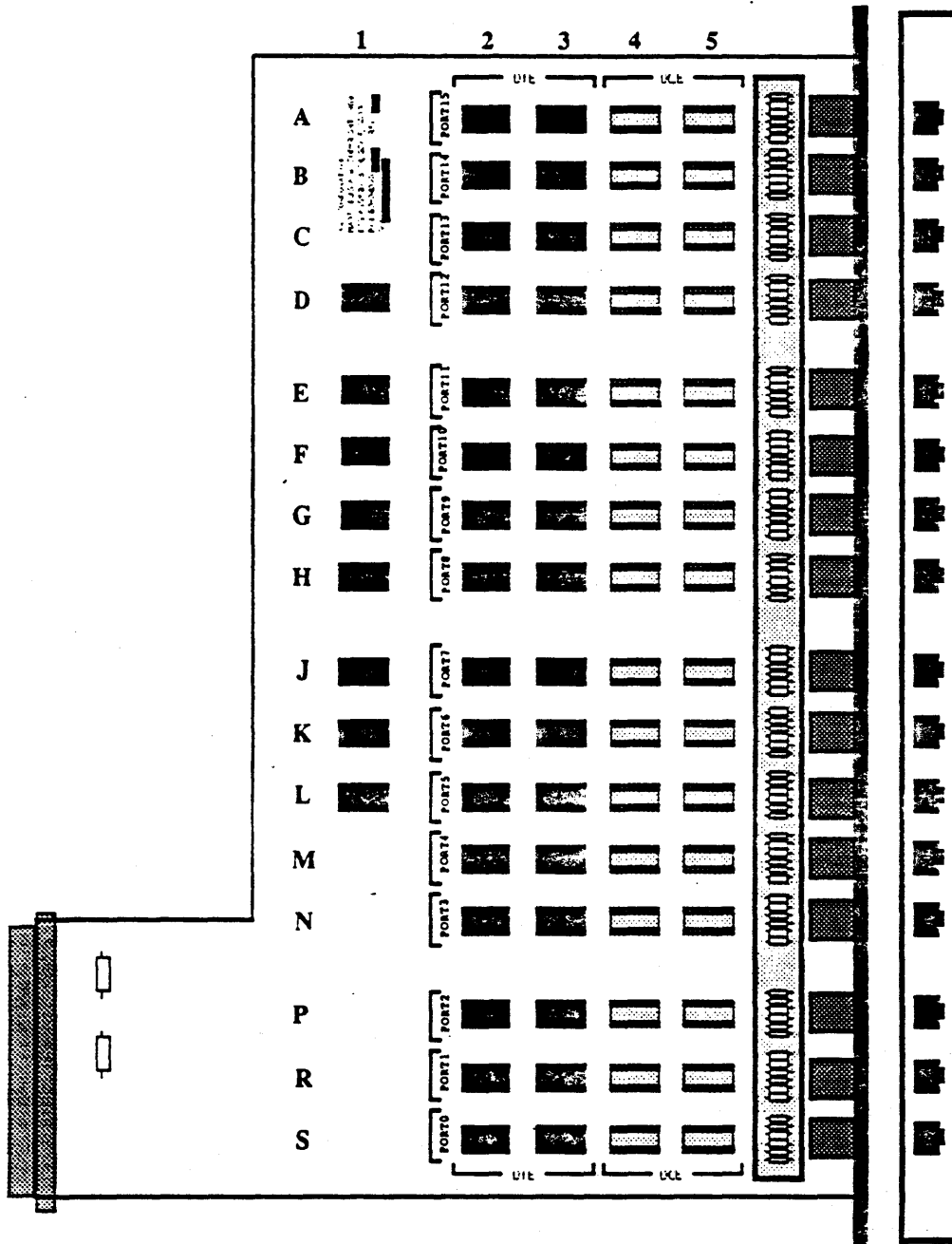

Figure 4-4. GC16 Interface Board

## SCSI INTERFACE BOARD SETUP

The SCSI board supports three internal and up to seven external SCSI disk drives, and provides a QIC-02 port for the cartridge tape drive. The SCSI logic and interface board must install in either IOCP slot 7 or 8 of the card cage.

Distance limits for both operation modes are:

- Single-ended: maximum distance is 6 meters
- Differential: maximum distance is 20 meters

Prior to installing the SCSI logic and interface board refer to the earlier sections, *Logic Board Installation* and *Interface Board Installation*. In Figure 4-5, *SCSI Interface Board*, Port 1 is configured for single-ended operation mode and Port 2 is configured for differential operation mode.

ARIX currently supports Port 1 (Local) configured as single-ended for the internal system SCSI disk drives and Port 2 (Remote) configured as differential for external SCSI drives.

### Single-ended Mode Configuration

Single-ended mode is for internal SCSI drives. The cable that connects to the port must not be longer than six meters. Port 1 is currently supported for single-ended mode.

Configure Port 1, as follows:

1. Install the terminators (two resistor ICs) between the middle and outside connector of the port being configured. Use the terminators that should be in the spare sockets on the board.
2. Install the short jumper cable between the middle and outer connectors.

ARIX currently supports Port 1 configured for single-ended operation mode.

### Differential Mode Configuration

Differential mode is for external SCSI drives. The cable that connects to the port must not be longer than 20 meters. Port 2 is currently supported for differential mode.

1. Remove the terminators (two resistor ICs) located between the middle and outside connector. Place the terminators in the spare sockets on the board for storage.
2. Install the long jumper cable between the inner and outer connectors.

ARIX currently supports Port 2 configured for differential operation mode.

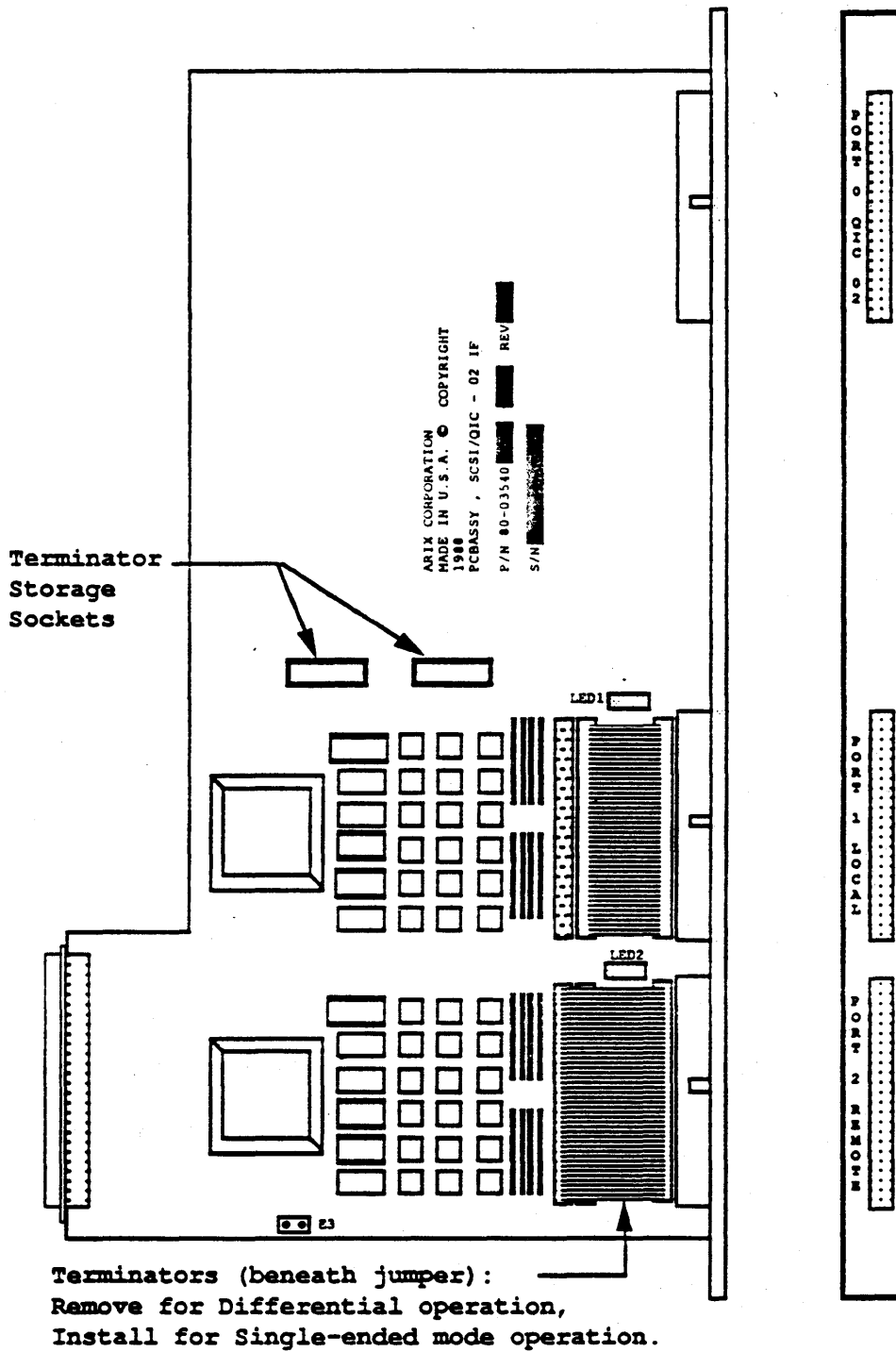

Figure 4-5. SCSI Interface Board

## MULTIBUS ADAPTER CARD SETUP

The MAC handles low to medium speed data transfers between a non-standard peripheral device and the system. Each MAC acts as the physical carrier and provides the electrical interconnecting interface to the ARIX system.

The Multibus Adapter Card (MAC) provides the following:

- Connection of bus controllers that are otherwise incompatible with an ARIX system.
- System integration of a wide variety of I/O interfaces from other vendors.

ARIX currently supports three different Multibus boards:

- X.25 communications board
- Ethernet communications board
- SCSI Optical disk board

Prior to installing a MAC, refer to the subsection *Logic Board Installation* in this Section. The Multibus board installs "piggy-back" onto the MAC. The following procedure explains the piggy-back installation of a Multibus board (refer to Figure 4-6, *Multibus Adapter Card with Multibus Board*):

1. Refer to the vendor documentation for the cabling information about the particular Multibus board being installed on the MAC.
2. Loosen the four screws (two in front and two in back) securing the "piggy-back" card support rails.
3. Plug the Multibus board into the MAC and route the cable(s) so it will not be an obstruction to the other boards. Ensure that the connector(s) is firmly in place.
4. Slide the support rails into place (on each side of the board) and tighten the four screws holding the support rails in place.

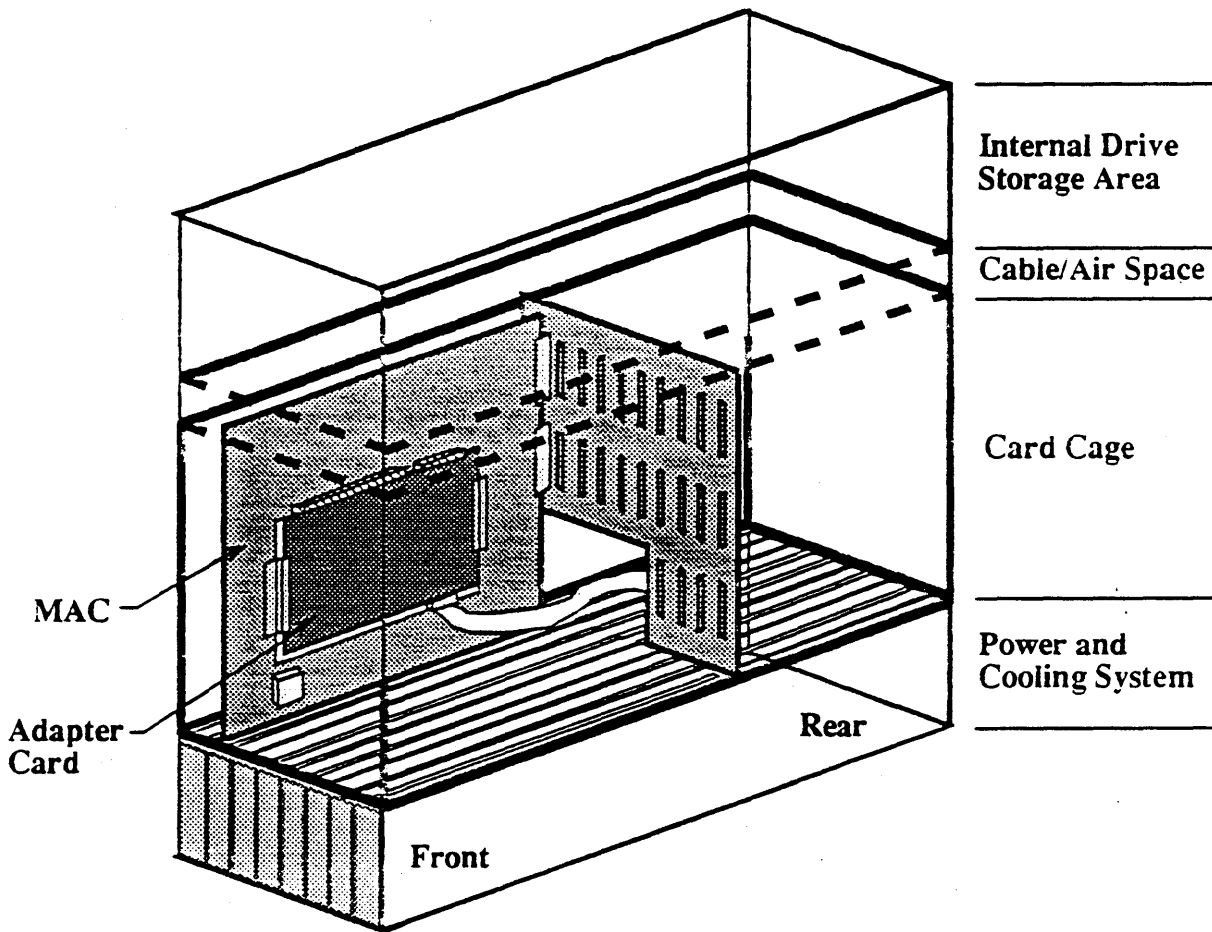

Figure 4-6. Multibus Adapter Card with Multibus Board

## VMEbus ADAPTER CARD SETUP

The VMEbus Adapter Card (VAC) supports the connection of VMEbus boards to the ARIX 825 system. The VAC routes VMEbus signals to the Interprocessor Communication Bus (ICB) and the Data Transfer Bus (DTB).

Each VAC requires one DMA channel of an ARIX system. If you have a DMC4/2 set as two channel, the VAC must have one of those channels. Thus, if your system has two EDT boards and you are installing a VAC, you must either remove one EDT or purchase a DMC4 board.

The VAC functions as a slave to the ICB with the capability of interrupting the master CPU. The master CPU uses the VAC to do single transfers of data between the VMEbus. The VAC occupies 64 Kbytes of ICB memory space.

ARIX provides a sample VME driver that you can use as a template for developing a specific VME application. To obtain a sample VME SMD driver, contact your ARIX representative or Customer Support.

The VAC occupies a single slot in the system card cage and accepts a double-height VMEbus board with P1 and P2 connectors. Figure 4-7, *VMEbus Adapter Card With VMEbus Board*, shows the VAC and an end-user board.

In order to run the VME SMD sample driver, the VAC-specific header files must be in the /include directory. Call ARIX Customer Support and verify that your system meets the current requirements.

The system requirements are, as follows:

- CPU PROM revision level of 1.4 or later
- UNIX System V.3
- One or more CPU 32/25 MHz boards in a pure system
- The current required header files to support the VME driver.

Prior to installing a VAC, refer to the subsection *Logic Board Installation* earlier in this Section. The VMEbus board installs "piggy-back" onto the VAC.

For specific information, refer to the *VAC Reference Manual, MA-04677-XX, Rev. A*.

The following procedure describes the piggy-back installation of a VMEbus board:

1. Refer to the vendor documentation for the cabling information about the particular VMEbus board you are installing on the VAC.
2. Loosen the four screws (two in front and two in back) that secure the "piggy-back" card support rails.
3. Plug the VMEbus board into the VAC.



4. Slide the support rails into place (on each side of the board) and tighten the four screws holding the support rails in place.
5. If the spare 64-pin connector P4 is being used, route the cable so it will not be an obstruction to the other boards. Ensure that the connector is firmly in place.
6. Return to the section *Logic Board Removal And Installation*, earlier in this Section and follow the procedures to install the VAC.

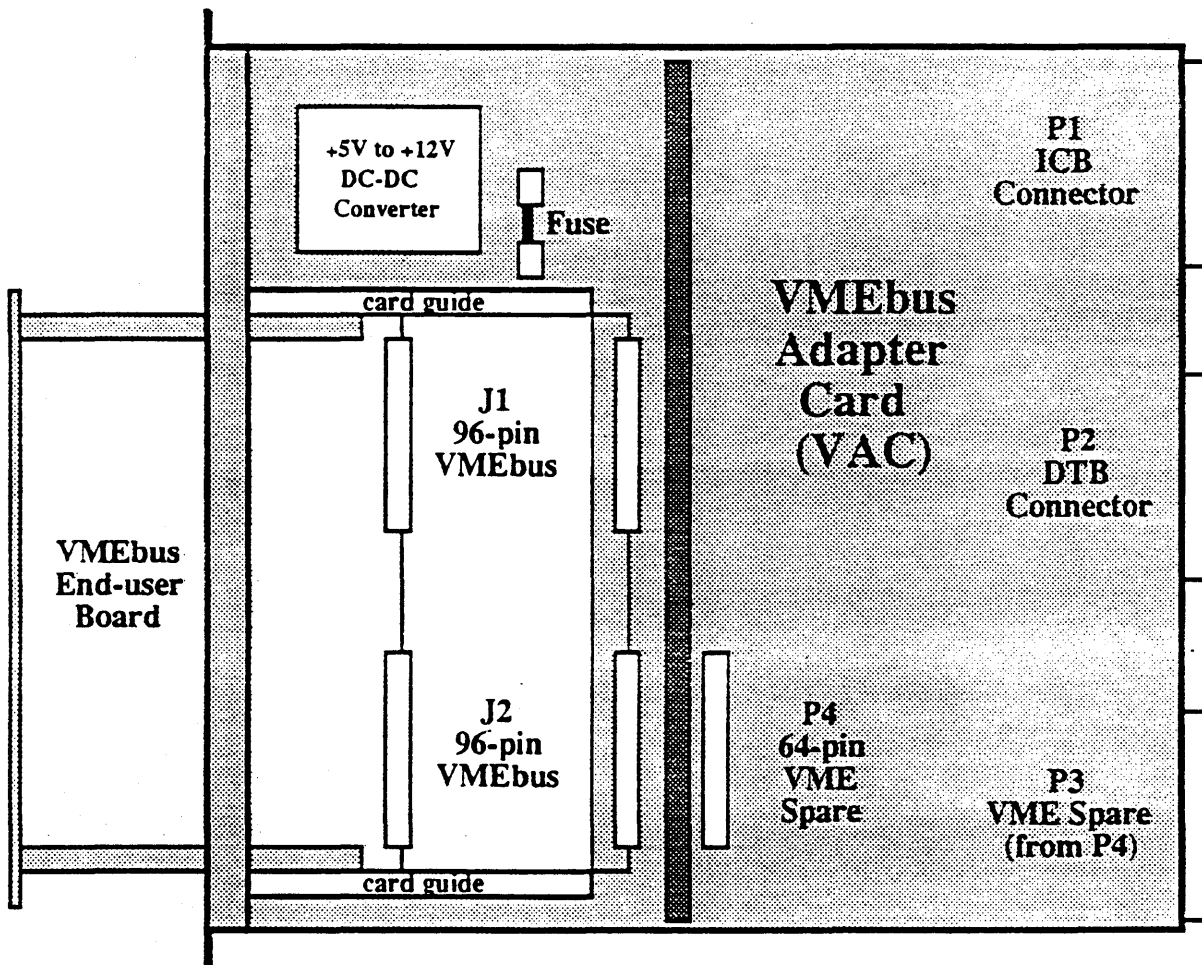
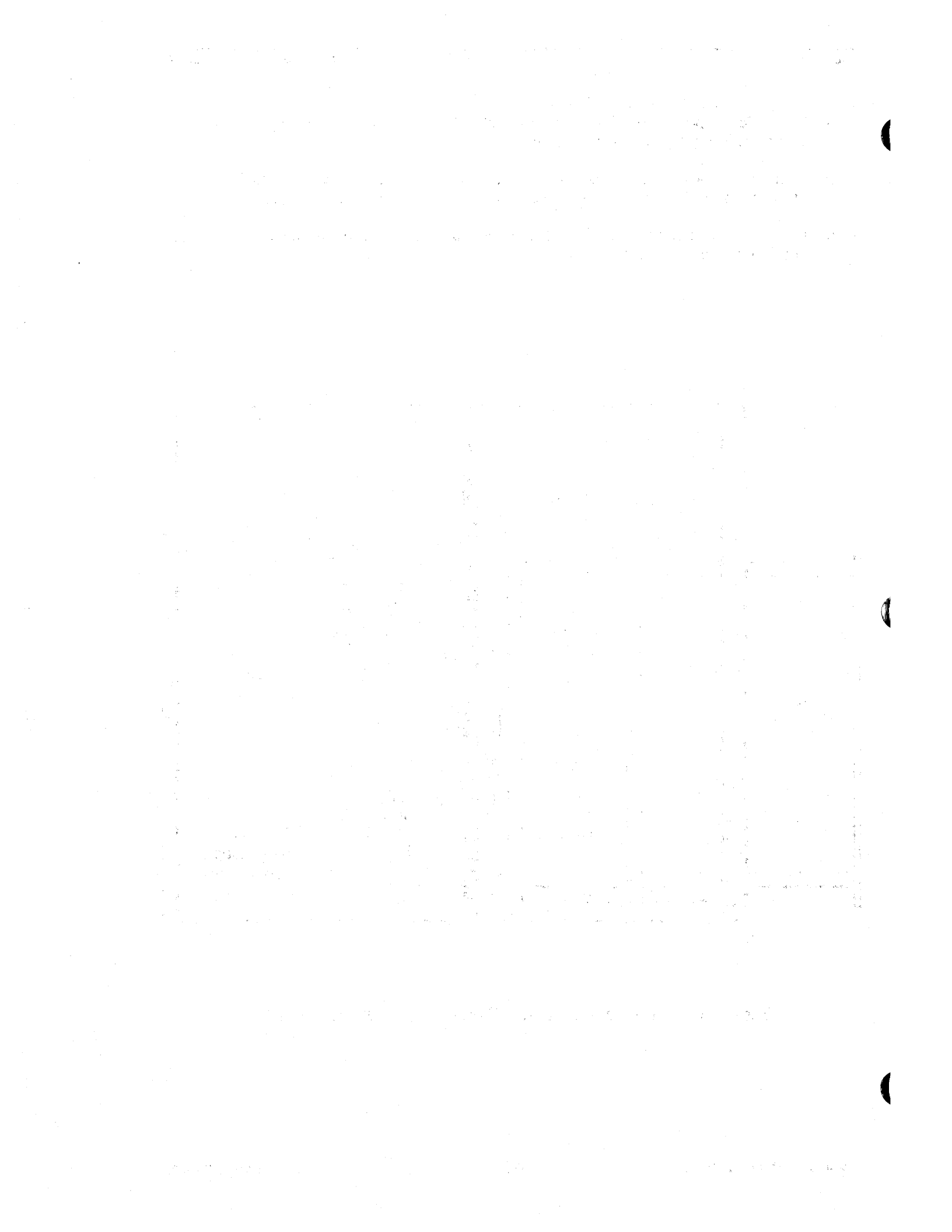
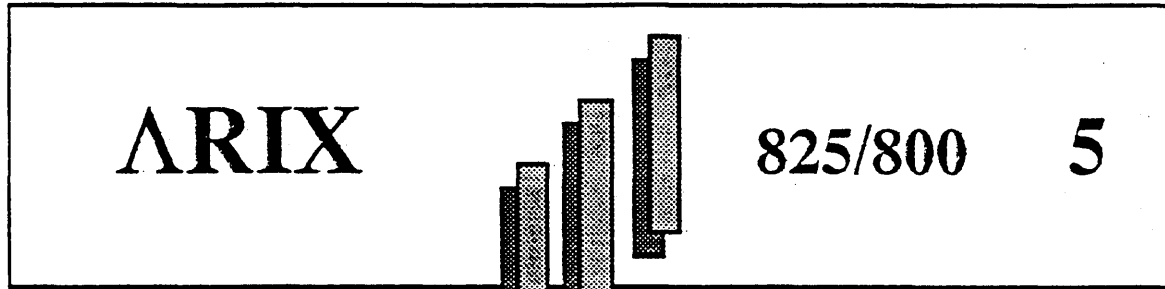

Figure 4-7. VMEbus Adapter Card with VMEbus Board





## Terminals Printers And Modems

This section describes the RS-232C standard and cabling and installation requirements for the console terminal, multiple terminals, serial and parallel printers, and modems.

### ***THE RS-232C STANDARD***

RS-232C is an industry standard for the electrical interface between Data Terminal Equipment (DTE) and Data Communications Equipment (DCE). The standard was adopted through the Electronic Industries Association (EIA) and is documented and supported by the Institute of Electrical and Electronic Engineers (IEEE). The RS-232C standard covers a wide range of device interconnections, transmission speeds, and data protocols.

The EIA standard defines voltage levels for signals. All signals must have a magnitude greater than three volts and less than fifteen volts; signals with a magnitude between zero and three volts are invalid.

The EIA standard defines two types of signals: control and data. The polarity of these signals determines the function (refer to Table 5-1, *EIA Voltage Definition*).

**Table 5-1. EIA Voltage Definition**

Voltage	Control	Data
+3 to +15	ON	0 or space
-3 to -15	OFF	1 or mark

The maximum supported RS-232C cable length is 50 feet. (Refer to Table 5-1, *Serial RS-232C And RJ-12 Signal Summary*.)

Table 5-2. Serial RS-232C And RJ-12 Signal Summary

Pin Number				
RJ-12	RS-232C	Abbr.	Direction	Signal Description
N/A	1	FG	N/A	Frame Ground is the protective ground between DCE and DTE.
2	2	TD	DTE to DCE	Transmit Data is output from DTE to DCE. Negative voltage is a mark or binary 1; positive voltage is a space or binary zero.
3	3	RD	DCE to DTE	Read Data is input from DCE to DTE. Negative voltage is a mark or binary 1; positive voltage is a space or binary zero.
N/A	4	RTS	DTE to DCE	Request To Send is output of positive voltage that must occur before data can be transmitted on pin 2.
N/A	5	CTS	DCE to DTE	Clear To Send acknowledges the Request to Send signal on pin 4 with output of positive voltage that must occur before data can be transmitted on pin 2.
1	6	DSR	DCE to DTE	Data Set Ready is output of positive voltage that signals readiness to transmit or to receive data. In most lease line applications, this signal is always positive. In switched line, this signal only outputs positive voltage when it is connected to the line.
4	7	SG	N/A	Signal Ground must be in place for the correct operation of the interface. It is the ground for data and control signals.
6	8	DCD	DCE to DTE	Data Carrier Detected is output of positive voltage when DCE is receiving a character from the line. Received Data on pin 3 is considered invalid unless this pin is "on".
N/A	15*	TC	DCE to DTE	Transmit Clock is output that controls the rate at which data is presented to synchronous modems.
N/A	17*	RC	DCE to DTE	Receive Clock is output that tells when to expect data on pin 3 from synchronous modems.
5	20	DTR	DTE to DCE	Data Terminal Ready is output of positive voltage from DTE to DCE that tells a modem to answer an incoming call. Data Set Ready (pin 6) can be the modem response to this signal. When Data Terminal Ready outputs negative voltage, a connected modem will disconnect from the line.

\* These signals are the clock lines used only with synchronous serial data transfers. The console terminal is any terminal that is connected to the RS-232C port (the lower connector) of the master CPU. The equipment needed is a terminal and a standard 25-pin RS-232C serial cable.

## CONSOLE TERMINAL INSTALLATION

The console terminal is any terminal that is connected to the RS-232C port (the lower connector) of the master CPU. The equipment needed is a terminal and a standard 25-pin RS-232C serial cable.

The internal cabling associated with the CPU board includes the console terminal cable and the remote diagnostic cable. Both connections are made directly to the CPU logic board.

On the front of the CPU board are two connectors with cables attached that are routed around the card cage. The lower connector is the console terminal cable, and the upper connector is the remote diagnostic modem cable.

### NOTE:

For the console terminal to operate, the terminal must be cabled to the master CPU.

Install the console terminal, as follows:

1. Unpack and setup the terminal in accordance with the instructions in the vendor manual.
2. Place the console near the main cabinet for convenience when performing routine administrative tasks (such as backups).
3. Plug the AC power cord of the console terminal into a primary power source.
4. Refer to the vendor manual to set the communications parameters as follows:
  - 9600 baud
  - one start bit
  - eight data bits
  - no parity bits
  - one stop bit
  - carriage return without line feed
  - handshake using XON/XOFF
  - full duplex
5. At the rear of the system, locate the CONSOLE port on the bottom-rear of the system (refer to Figure 5-1, *Model 825/800, Rear View*) and secure one end of the RS-232C serial cable to this port.
6. Secure the other end of the serial cable to the appropriate RS-232C port on the terminal. Refer to the vendor manual to find the correct port on the rear of the terminal.

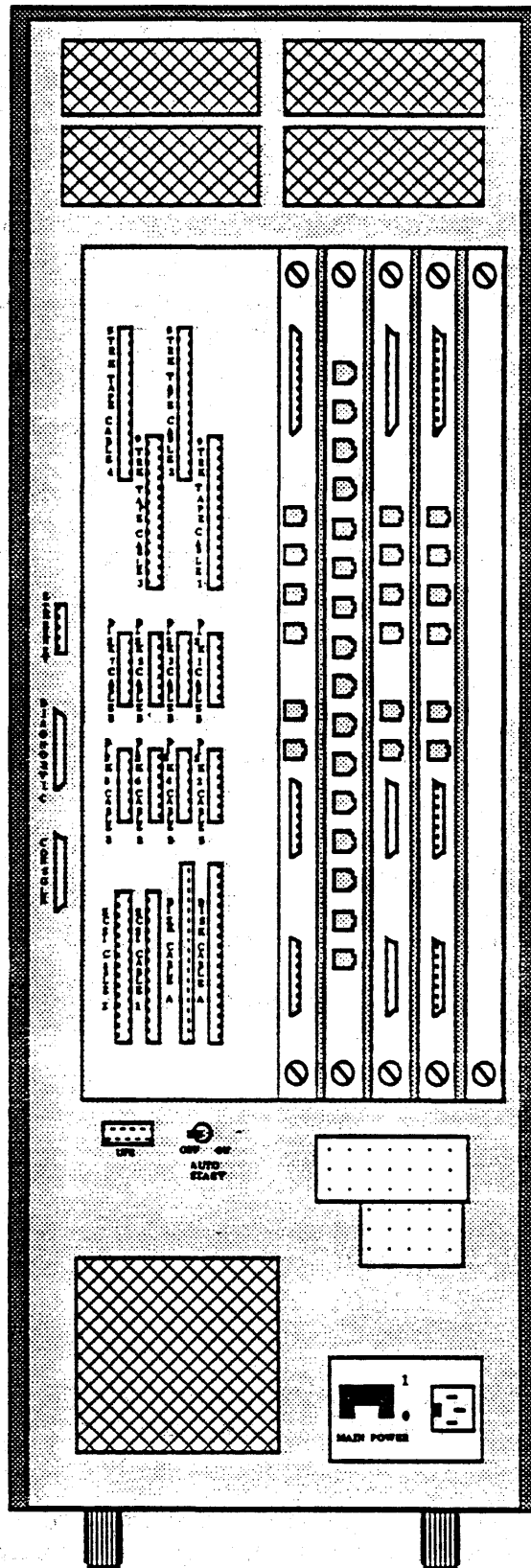

Figure 5-1. Model 825/800, Rear View

## **CPU32 REMOTE DIAGNOSTIC CONSOLE**

This section describes procedures to install the internal CPU32 remote diagnostic console ribbon cable.

With the master CPU32 (12.5 MHz), or CPU32/25 (25 MHz), you can modify the system to allow the user to remotely (through a modem) diagnose the system. The major advantage of the remote diagnostic console is in the ability to troubleshoot the system off-site.

On the front of the CPU32 or CPU32/25 board are two connectors; the lower connector is the console connection, and the upper connector is for the remote diagnostic modem cable.

A system configured at the factory is internally cabled, and ready for remote or local operation. A system upgrade to a master CPU32 requires the connection of the two internal ribbon cables to the front of the new master CPU board.

Figure 5-1 shows the detail of the rear panel, with the console and remote diagnostic ports, the serial (RJ-12 asynchronous and DB-25 asynchronous or synchronous connectors) and parallel printer ports.

The console cable always connects to the bottom location (CONSOLE), the remote diagnostic modem cable connects to the middle location (REMOTE), the top connector is reserved for an Ethernet connection, and the Uninterruptible Power Supply (UPS) is next to the AUTO START switch.

Connect the diagnostic modem cable, as follows:

1. Connect the remote diagnostic modem cable (with the red edge down to align pin 1) to the modem port on the CPU32 board.
2. Connect the other end of the cable to a modem.

The data transfer rate for the remote console is 1200 baud. If you use the remote port, the console port automatically defaults to 1200 baud.

Once a remote terminal is communicating through the remote diagnostic port via the modem connection, it acts exactly like the console. When used together, both the system console and remote console can be used to key in commands to the system, with each displaying the same information simultaneously.

## MULTIPLE TERMINAL INSTALLATION

This subsection describes the installation procedures necessary to install and cable multiple terminals.

Refer to the manufacturer's terminal manual for signal line, and specific information applying to the terminal being used. Most terminals require a minimum of four standard signal lines, as follows:

Direct Connect	No modem or phone connection between devices.
Full Duplex	Data transfers in both directions at the same.
Asynchronous	Data transfers are not at the same time, nor in phase. Each character transmitted asynchronously is preceded by a start bit and is followed by a stop bit. The interval between each character may vary, but the bit by bit interval for each character is constant. This is appropriate for the random pace of data entry at a terminal keyboard.

The line is held in a mark (binary 1) state when data is not being transmitted. The stop bit is a mark state, and the start bit is a space (binary 0) state.

XON/XOFF Protocol	A device transfers data into the receiving device's buffer. When the buffer is full, the receiving device sends an XOFF indicating to the transmitting device that the buffer is full. When there is room in the buffer, an XON is sent by the receiving device as a request to continue the data transfer. This process continues until all data is sent, allowing the system to attend to other tasks without waiting for this process to finish.
-------------------	---

The GC/EGC/GC16 synchronous and/or asynchronous serial data ports can be configured to operate as DCE or DTE. The modem or terminal IC groups on the GC/EGC/GC16 interface board are relocated to configure one or all ports to either DTE or DCE (refer to Section 4, *GC/EGC/GC16 Interface Board Setup*).

When installing a cable, note which terminal (by location) is connected to which port, so each terminal can be identified by its port location. Write this information in a log, and keep the log near the system for handy reference.



Install each terminal, as follows:

1. Unpack and install the terminal in accordance with the vendor's instructions.
2. Plug the AC power cord of the terminal into a primary power source.
3. Refer to the vendor manual to set the communications parameters as follows:
  - 9600 baud (or to the setting of the existing host /etc/inittab file or stty value)
  - One start bit
  - Eight data bits
  - No parity bits
  - One stop bit
  - Carriage return without line feed
  - Handshake using XON/XOFF
  - Full duplex
4. Label both ends of each cable with the same designator for later identification. This avoids having to find a connector at the other end.
5. Connect one end of the serial cable to the RS-232C port (use the RJ-12 to RS-232C adapters) on the terminal.
6. Run the serial cable to the ARIX system. Allow approximately 12 inches slack in each cable for strain relief, and to reach from the floor to the I/O connector on the lower rear panel.
7. Connect the male connector of each terminal cable to a corresponding female connector.
8. Secure the connectors to the rear panel.

## **PRINTER INSTALLATION**

This subsection describes the procedures to install external serial and parallel printers. Typically, serial printers require six of the standard RS-232C pins (pins 2, 3, 6, 7, 8, and 20). Parallel printers use the XON/XOFF protocol. (Refer to the manufacturers' printer manual, and to Table 5-1, *Serial RS-232C And RJ-12 Signal Summary*).

To configure your ARIX system to your specific printer, refer to LP Spooler Administration Procedures in the *System Administrator's Guide*, and LPADMIN(1M) in the *System Administrator's Reference Manual*.

Connect a serial printer to the system, as follows:

1. Unpack and install the printer according to the instructions in the vendor manual provided with the unit.
2. Connect one end of the RS-232C serial cable to the serial port of the printer.
3. Connect the other end of the RS-232C cable to a serial port on the rear panel of the system.

ARIX supports a Centronics parallel interface using the common 7-bit parallel interface. An optional 8th bit is available as required by the user.

Connect a Centronics compatible parallel printer, as follows:

1. Unpack and install the printer according to the instructions in the vendor manual provided with the unit.
2. Connect one end of the parallel cable to the parallel port of the printer.
3. Connect the other end of the cable to the parallel port on the rear panel of the system.

## MODEMS

This subsection describes connecting a modem to an ARIX system. Table 5-2 describes the signals required for both RS-232C asynchronous and synchronous and RJ-12 asynchronous modems.

Prior to connecting a modem to an ARIX system, refer to the vendor's modem manual to determine whether the modem is asynchronous or synchronous.

Asynchronous modems use start and stop bits. Synchronous modems use transmit and receive clocks to control all communications.

### NOTE:

For correct operation between the modem and the system, the modem, the cable, and the GC/EGC/GC16 interface board must be properly configured. (Refer to Section 4, *Printed Circuit Boards; GC/EGC Interface Setup* or *GC16 Interface Setup*, and the vendor's modem and cable manuals.)

Install the modem, as follows:

1. Unpack and install the modem according to the instructions in the vendor manual provided with the unit.
2. Connect one end of the serial cable to the serial port of the modem.
3. Connect the other end of the cable to a serial port on the rear of the system, as follows:
  - For synchronous modems, connect the cable to a synchronous port of the GC8 interface board (port 0 or port 1).
  - For asynchronous modems, connect the cable to an asynchronous port of the GC8 (ports 2 through 7) or GC16 (ports 1 through 16) interface board.



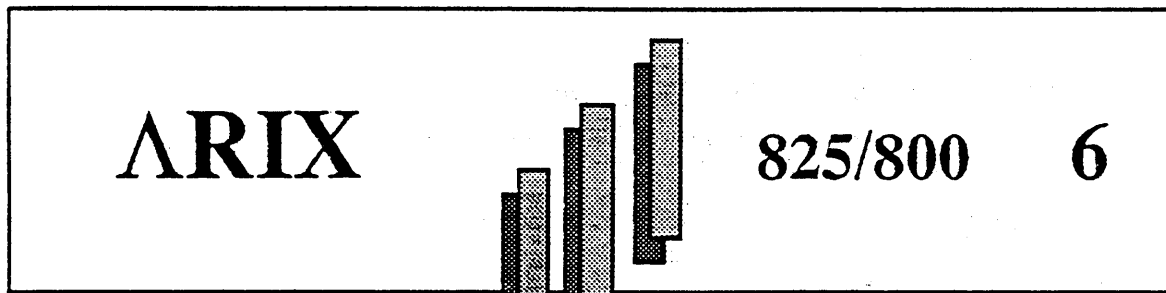

## Subassembly Removal And Installation

This section describes removal and installation procedures for the following Field Replaceable Units (FRUs) in an ARIX Model 825/800 system:

- Keyswitch
- Fans
- Cartridge Tape Drive
- Disk Drives
- Power Supply

The tools required for this section are a phillips and a flathead screwdriver.

In order to maintain the quality and integrity of the system, ARIX recommends that those that have not taken the *ARIX Systems Installation and Maintenance* class, do so. Graduates of the class are qualified to maintain the system. Call ARIX Customer Support for assistance before attempting to perform any of the procedures in this section.

### CAUTION:

**Remove system power. (Refer to Section 3, *System Startup and Shutdown.*)**

## ***INTERNAL DRIVE STORAGE AREA***

The Internal Drive Storage Area resides in the top of the system and contains the cartridge tape drive and up to three SMD or SCSI disk drives.

This section describes opening the top of the system to obtain access to the internal tape and disk drives and reassembling the top of the system.

These procedures pertain to the following procedures in this Section:

- Cartridge Tape Drive
- SMD or SCSI disk drives
- Cooling fan (systems that use the horizontal-mount SCSI disk drives only)

### ***Accessing The Internal Drive Storage Area***

Access the disk area, as follows:

1. Remove the front cover: at the front of the system, pull out on edges of the cover until the cover pops off.
2. Remove the upper air vent: from the rear of the system, remove the phillips screws that secure the air vent to the system. Save the screws.
3. Remove the system top cover: remove the two phillips screws located inside and underneath the rear of the the system top cover. Save the screws. Slide the top cover towards the rear of the system and lift it off.
4. Remove the top shield plate: remove the phillips screws that secure the top shield plate to the edges of the system, and the screws (two per drive) that secure the internal disk drives. Save the screws. Note the orientation of the top shield plate: the two square holes are toward the front of the system.

## ***Reassembly Of The Internal Drive Storage Area***

Reassemble the top of the system, as follows:

1. **Replace the top shield plate:** place it on the top of the system (with the two square holes toward the front of the system) and secure the top shield plate with the phillips screws that were previously removed. Note that the disk drives each use two phillips screws to secure them to the top shield plate.
2. **Replace the system top cover:** insert the two metal tongues of the top cover into the two holes of the top shield plate slide the top cover towards the front of the system.
3. **Secure the top cover to the system:** replace the two phillips screws located inside and underneath the rear edge of the system.
4. **Replace the front cover of the system:** align the front cover studs with the holes on the front of the system and press until the cover pops on.
5. **Secure the upper rear air vent to the system,** use the phillips screws that were previously removed.

## **CARTRIDGE TAPE DRIVE ASSEMBLY**

The cartridge tape drive is located at the top-front of the system. The following subsections describe procedures to remove and install the cartridge tape drive assembly.

Use the procedures in the earlier section, *Internal Drive Storage Assembly*, to access and reassemble the drive storage area.

Figure 6-1, *Internal Rear View*, shows the placement of the cartridge tape drive, cable layout and connections to the power control board.

The EDT, HSDT and SCSI interface boards support the QIC-02 interface for the cartridge tape drive.

Two types of cartridge tape drives are available, as follows:

- Archive Viper half-height tape drive
- Wangtek full-height tape drive

### ***Removing a Cartridge Tape Drive***

Remove a cartridge tape drive, as follows (refer to Figure 6-1, *Internal Rear View*):

1. Follow the procedures in the earlier section, *Internal Drive Storage Assembly*, to access the cartridge tape drive.
2. At the rear of the tape drive, label and remove the tape interface ribbon cable that attaches to the bottom of the drive controller board located inside the cartridge tape drive assembly. Note that Pin 1 is down.
3. Remove the cartridge tape drive power connector(s), as follows:
  - The Wangtek is a full-height drive with two 4-pin power connectors. Label and remove the 4-pin power connector that connects to the top of the drive controller board (inside the tape drive assembly), and the 4-pin power connector located at the rear of the tape drive.
  - The Archive Viper is a half-height drive with one 4-pin power connector. Label and remove the 4-pin power connector that connects to the top of the drive controller board (inside the tape drive assembly).

Note the orientation of the connector(s) before removal. The connectors are keyed to prevent improper insertion.

4. At the top of the tape drive, remove the phillips screws that secure the drive to the system. Save the screws.
5. From the front of the system, remove the drive: pull the drive towards the front of the system. Note that the labels on the tape drive are on the top of the drive towards the right.



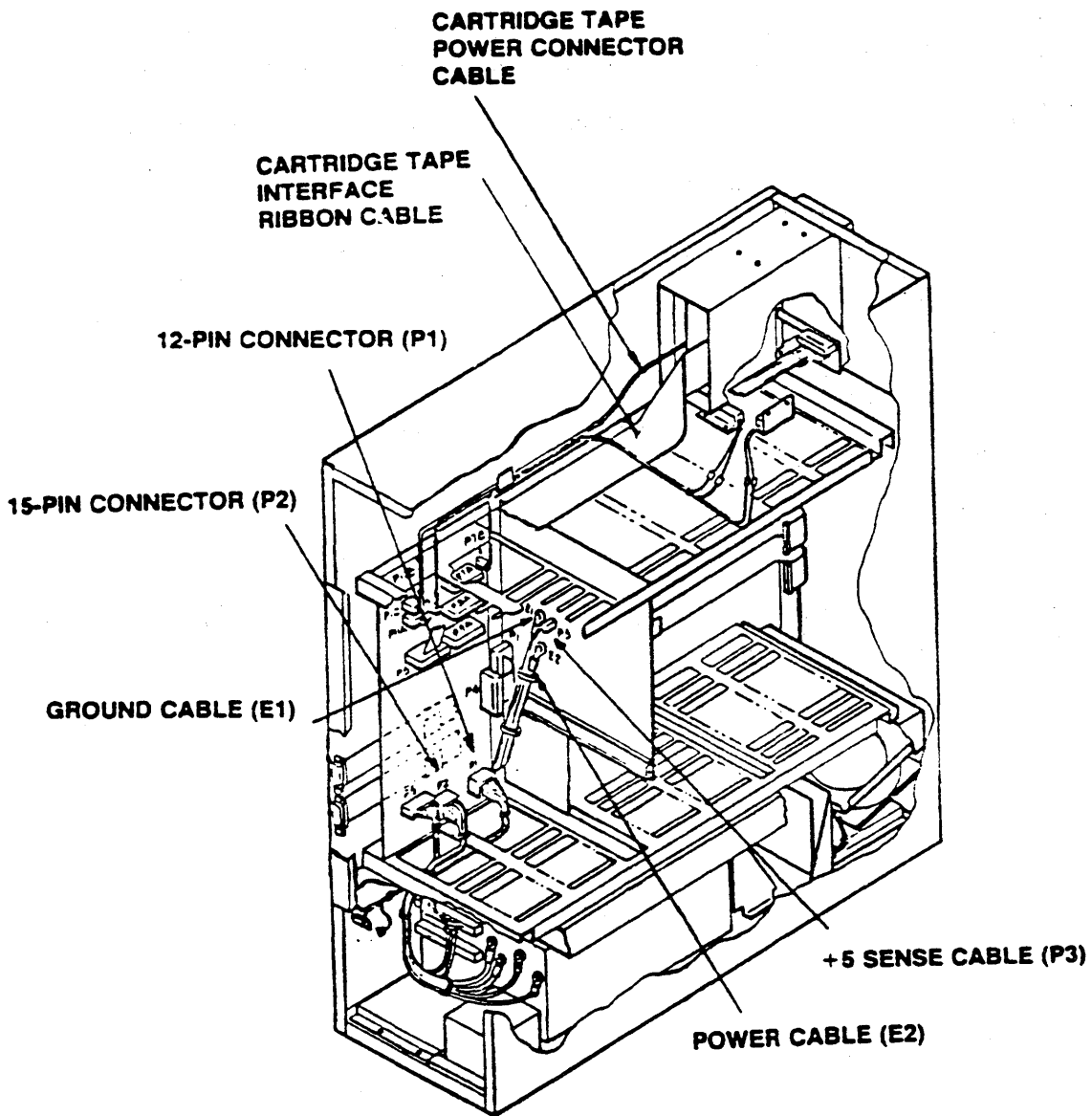

Figure 6-1. Internal Rear View

## ***Installing a Cartridge Tape Drive***

Use the procedures in the earlier section, *Internal Drive Storage Assembly*, to access and reassemble the drive storage area.

Install a cartridge tape drive, as follows (refer to Figure 6-1, *Internal Rear View*):

1. From the front of the system with the label of the tape drive facing up and towards the right, slide the drive back into the upper front of the system (above the keyswitch).
2. Align the tape drive bracket holes with the screw holes and replace the screws.
3. Connect the cartridge tape drive power connector(s), as follows:
  - The Wangtek is a full-height drive with two 4-pin power connectors. Connect the 4-pin power connector to the top rear of the disk controller board (inside the tape drive assembly), and connect the 4-pin power connector to the rear of the tape drive.
  - The Archive Viper is a half-height drive with one 4-pin power connector. Connect the 4-pin power connector to the top rear of the disk controller board (inside the tape drive assembly).
4. Connect the tape interface ribbon cable to the bottom rear of the tape controller board located inside the cartridge tape drive assembly. Pin 1 is down.
5. Follow the procedures in the earlier section, *Internal Drive Storage Assembly*, and reassemble the top of the system.

## ***KEYSWITCH ASSEMBLY***

The following subsections contain procedures to remove and install the keyswitch assembly. (Refer to Figure 6-2, *Internal Front View*.)

### ***Removing the Keyswitch Assembly***

Remove a keyswitch assembly, as follows:

1. At the front of the system, remove the upper front cover by pulling out on the edges until the cover pops off.
2. Remove the phillips screws that attach the keyswitch to the front of the system.
3. Inside the system, behind the keyswitch assembly, label and remove the 5-pin keyswitch connector. Note the orientation of the connector before removing it.
4. Pull the keyswitch assembly towards the front of the system until it is completely out.

### ***Installing the Keyswitch Assembly***

Install the keyswitch assembly, as follows:

1. Place the 5-pin keyswitch connector through the hole for the keyswitch at the front of the system and plug it into the rear of the keyswitch assembly (inside the system behind the front plate).
2. Align the keyswitch assembly with the holes at the front of the system and replace the screws.
3. At the front of the system, replace the upper front cover: align it with the studs on the system, then press in until the front cover pops on.

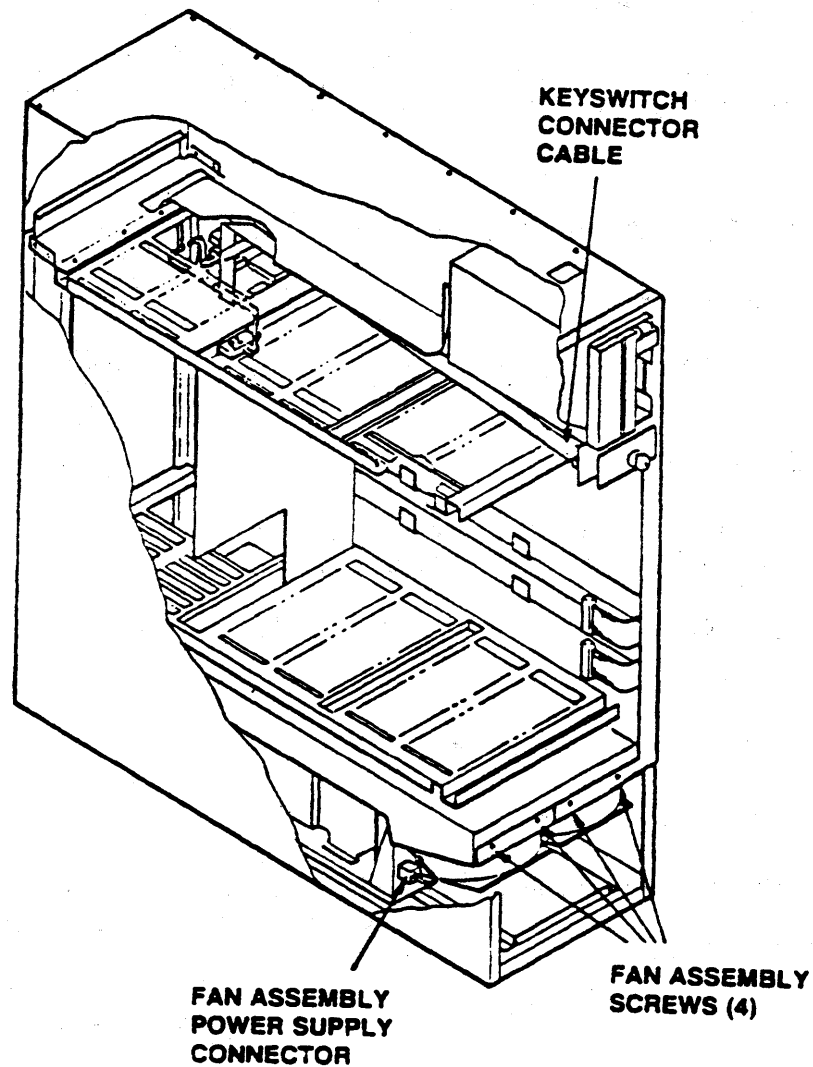

Figure 6-2. Internal Front View

## FAN ASSEMBLIES

This section describes removing and installing the following:

- The main fan assembly: all systems.
- The drive storage assembly: systems with horizontal-mount SCSI disk drives (refer to Figure 6-8, *Horizontal-Mount SCSI Drives*).

## Main Fan Assembly

The main fan assembly resides in the front lower section of the system (refer to Figure 6-2, *Internal Front View*).

### REMOVING THE MAIN FAN ASSEMBLY

At the front of the system, remove the main fan assembly, as follows:

1. Remove the bottom front cover: pull the cover out and down.
2. Label and remove the connector to the power supply: under the left fan, squeeze the connector tabs and pull out on the connector at the same time. Note the orientation of the connector before removal. This connector is keyed to prevent improper insertion.
3. Remove the four phillips screws (two per fan, one fan at a time) located directly under the upper front cover.

#### NOTE:

Make a note of the colors of the wires on the fan. The blue wire is negative (-) and the violet wire is positive (+).

4. Remove the fan assembly (two fans and connector) out of the system.

### INSTALLING THE MAIN FAN ASSEMBLY

Install the fan assembly, as follows (refer to Figure 6-2, *Internal Front View*):

1. Place the fan assembly (two fans) into the lower front of the system.
2. Align the metal brackets of each fan with the screw holes and replace the two phillips screws for each fan.
3. Attach the power connector, under the left fan, to the power supply.
4. Replace the lower front cover of the system: insert the metal grooves into the slots (below the card cage), push up and in on the bottom of the cover until it pops on.

## ***Drive Storage Fan Assembly***

The 825/800 systems that have horizontal-mount SCSI disk drives have an additional fan assembly in the drive storage assembly (refer to Figure 6-8, *Horizontal-Mount SCSI Drives*).

To access and to reassemble the drive storage fan assembly, follow the procedures given at the beginning of this section, *Internal Drive Storage Assembly*.

### ***REMOVING THE DRIVE STORAGE FAN ASSEMBLY***

With access to the disk tray, remove the fan assembly, as follows:

1. From the front of the system, remove the left side panel.
2. Disconnect the fan power cable.
3. Remove the two phillips screws that secure the drive to the side of the system. Save the screws.
4. Remove the two screws that secure the fan to the disk tray plate. Save the screws.
5. Remove the fan.

### ***INSTALLING THE DRIVE STORAGE FAN ASSEMBLY***

Install the fan assembly, as follows:

1. Insert the fan into the system and align the screw holes.
2. Replace the four phillips screws: two screws secure the fan to the disk tray plate and two screws secure the fan to the side of the system.
3. Connect the power cable to the fan.
4. Attach the side panel to the system.

## ***DISK DRIVE ASSEMBLIES***

The ARIX 825/800 system supports both SMD and SCSI hard disk drives. Currently, having both types of drives installed internally is not supported. Within the system cabinet, only 5-1/4" diameter drives are available.

With SCSI disk drives, drive 0 is always the terminating drive and designated to have the required terminator at the end of the daisy-chained ribbon cable.

This section explains removal and installation procedures for the following:

- Vertical-mount SMD drives
- Vertical-mount SCSI drives
- Horizontal-mount SCSI drives

Use the following figures as references to the configuration and removal or installation of your disk drive(s):

**Figure 6-3, *HSMD/SMD Disk Drive Settings***

The component side of the drive board with details of the address jumper configurations.

**Figure 6-4, *Vertical-Mount HSMD/SMD Drives***

An internal view of vertical-mount SMD drives with detail to the routing of the cables from the drives to the interface board.

**Figure 6-5, *Vertical-Mount SCSI Drives***

An internal view of vertical-mount SCSI drives with detail to the routing of the cables from the drives to the interface board.

**Figure 6-6, *CDC 170 Mbyte SCSI Disk Drive Setting***

**Figure 6-7, *CDC 380 Mbyte SCSI Disk Drive Settings***

These drive configuration labels should be attached to the SCSI drive; show how to configure a 170 or 380 Mbyte SCSI drive.

**Figure 6-8, *Horizontal-Mount SCSI Drives***

An internal view of horizontal-mount SCSI drives with detail to the routing of the cables from the drives to the interface board.

## ***Vertical HSMD/SMD Disk Drives***

Removal and installation of the HSMD/SMD drives require the disconnection/connection of the following three cables:

- **Data Cable:** a 60-pin ribbon cable in a daisy-chain configuration that connects from drive 0 (always the terminating drive on the daisy-chain) to drive 1 to drive 2 and to port P7 on the EDT interface board.
- **Control Cable:** a 26-pin ribbon cable that connects between the disk drive and one of the control ports on the EDT board.
- **Power Cable:** a 20-wire cable and 20-pin connector that provides power to the drive.

The following subsections provide the instructions to remove and install the vertical-mount HSMD/SMD 170 and 380 Mbyte hard disk drives.

### ***REMOVING A VERTICAL-MOUNT HSMD/SMD DISK DRIVE***

Remove a vertical disk drive, as follows:

1. Remove the system side panel to access the drive: grasp and pull out on the two edges of the side panel.
2. Remove and label the following three cables (from the rear of the disk drive):
  - a. The 60-pin data ribbon cable. Note that pin 1 of the cable is up.
  - b. The 20-pin black power cable. Note the orientation of the connector.
  - c. The 26-pin control ribbon cable. Note pin 1 of the cable is up.
3. Remove the four phillips screws (two screws per bracket) that hold the drive's brackets to the system.
4. Remove the drive (with the brackets) from the system .

The the address jumper configuration of this disk drive may be used for setting the address jumper configuration on the new drive. (Refer to Figure 6-3, *SMD Disk Drive Settings*.)



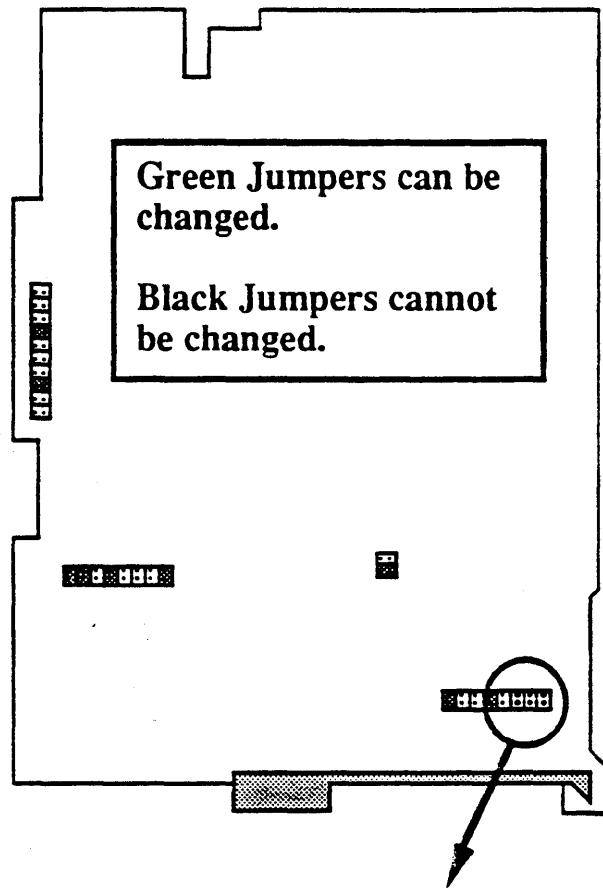

Logical Device Number																																						
0	1	2																																				
<table border="1"> <tr><td>12</td><td>11</td><td>10</td><td>9</td></tr> <tr><td>■</td><td>■</td><td>■</td><td>■</td></tr> <tr><td>5</td><td>6</td><td>7</td><td>8</td></tr> </table>	12	11	10	9	■	■	■	■	5	6	7	8	<table border="1"> <tr><td>12</td><td>11</td><td>10</td><td>9</td></tr> <tr><td>□</td><td>■</td><td>■</td><td>■</td></tr> <tr><td>5</td><td>6</td><td>7</td><td>8</td></tr> </table>	12	11	10	9	□	■	■	■	5	6	7	8	<table border="1"> <tr><td>12</td><td>11</td><td>10</td><td>9</td></tr> <tr><td>■</td><td>□</td><td>■</td><td>■</td></tr> <tr><td>5</td><td>6</td><td>7</td><td>8</td></tr> </table>	12	11	10	9	■	□	■	■	5	6	7	8
12	11	10	9																																			
■	■	■	■																																			
5	6	7	8																																			
12	11	10	9																																			
□	■	■	■																																			
5	6	7	8																																			
12	11	10	9																																			
■	□	■	■																																			
5	6	7	8																																			

□ No Jumper  
■ Jumpered

Figure 6-3. SMD Disk Drive Settings

**INSTALLING A VERTICAL-MOUNT HSMD/SMD DISK DRIVE**

Install the disk drive, as follows (refer to Figure 6-4, *Vertical-Mount HSMD/SMD Drives*):

1. Configure the disk drive address jumpers on the new drive by referring to the jumper settings on the old drive, or setting the jumpers as shown in Figure 6-3, *SMD Disk Drive Settings*.

**NOTE:**

If more than one drive is being installed in the system, you must configure the address jumpers (refer to Figure 6-3, *SMD Disk Drive Settings*).

2. Install the following three cables (from the rear of the disk drive):
  - a. The 60-pin data ribbon cable. Note that pin 1 of the cable is up.
  - b. The 20-pin black power cable. Note the notch of the male to female connectors.
  - c. The 26-pin control ribbon cable. Note pin 1 of the cable is up.
3. Align the two brackets that are attached to the drive to the screw holes on the upper edge of the side of the system the drive is being installed.
4. Replace the four phillips screws (two per bracket) that secure the disk drive to the side of the system.
5. Route the drive's cable as shown in Figure 6-4, *Vertical-Mount HSMD/SMD Drives*.
7. Replace the side panel: align the studs of the panel to the system and push until the panel snaps on.
8. Reassemble the system (refer to the previous section, *Internal Drive Storage Area*).

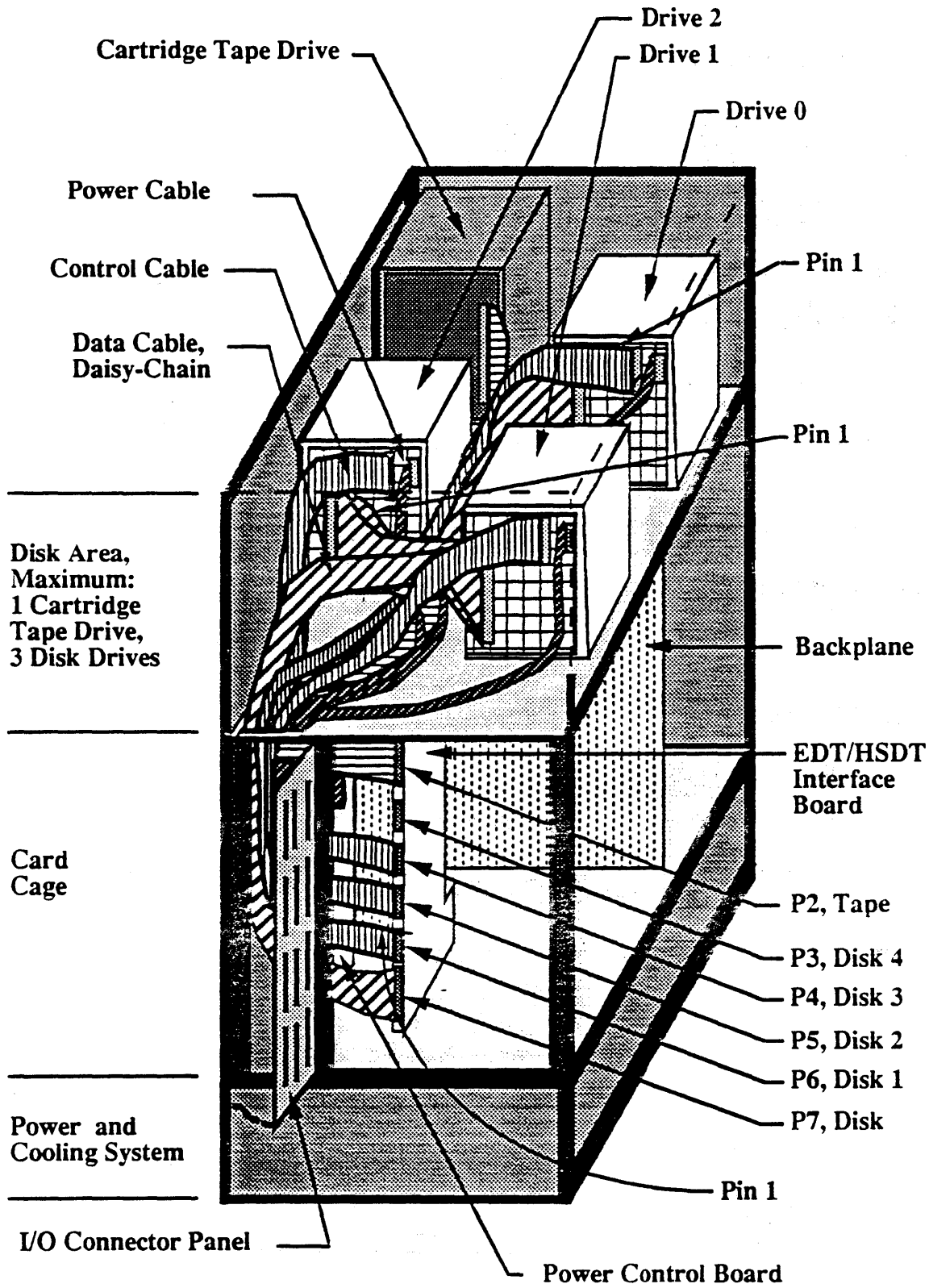

Figure 6-4. Vertical-Mount HSMD/SMD Drives

## *Vertical SCSI Disk Drives*

The following subsections provide the instructions to remove and install the vertically-mounted SCSI 170 or 380 Mbyte hard disk drives.

Removal and installation of the SCSI drives require the disconnection/connection of the following two cables:

- **Data and Control Cable:** a 50-pin ribbon cable in a daisy-chain configuration that connects from drive 0 (always the terminating drive on the daisy-chain) to drive 1 to drive 2 and to port 1, Local, on the SCSI interface board.
- **Power Cable:** a 4-wire cable that provides power to the drive.

Figure 6-5, *Vertical-Mount SCSI Drives*, shows an internal view of the 825/800 with detail of the routing of the cables between the drives and the SCSI board.

### **REMOVING A VERTICAL-MOUNT SCSI DISK DRIVE**

Remove the disk drive, as follows:

1. Remove the system side panel to access the drive: grasp and pull out on the two edges of the side panel.
2. Label and remove the following two cables (from the rear of the disk drive):
  - a. The 50-pin data/control ribbon cable. Note that pin 1 of the cable is up.
  - b. The 4-pin black power cable. Note the notch of the connector.
3. From the side of the system, remove the four phillips screws (two screws per bracket) that hold the drive's brackets to the system.
4. Remove the drive (with the brackets) from the system.

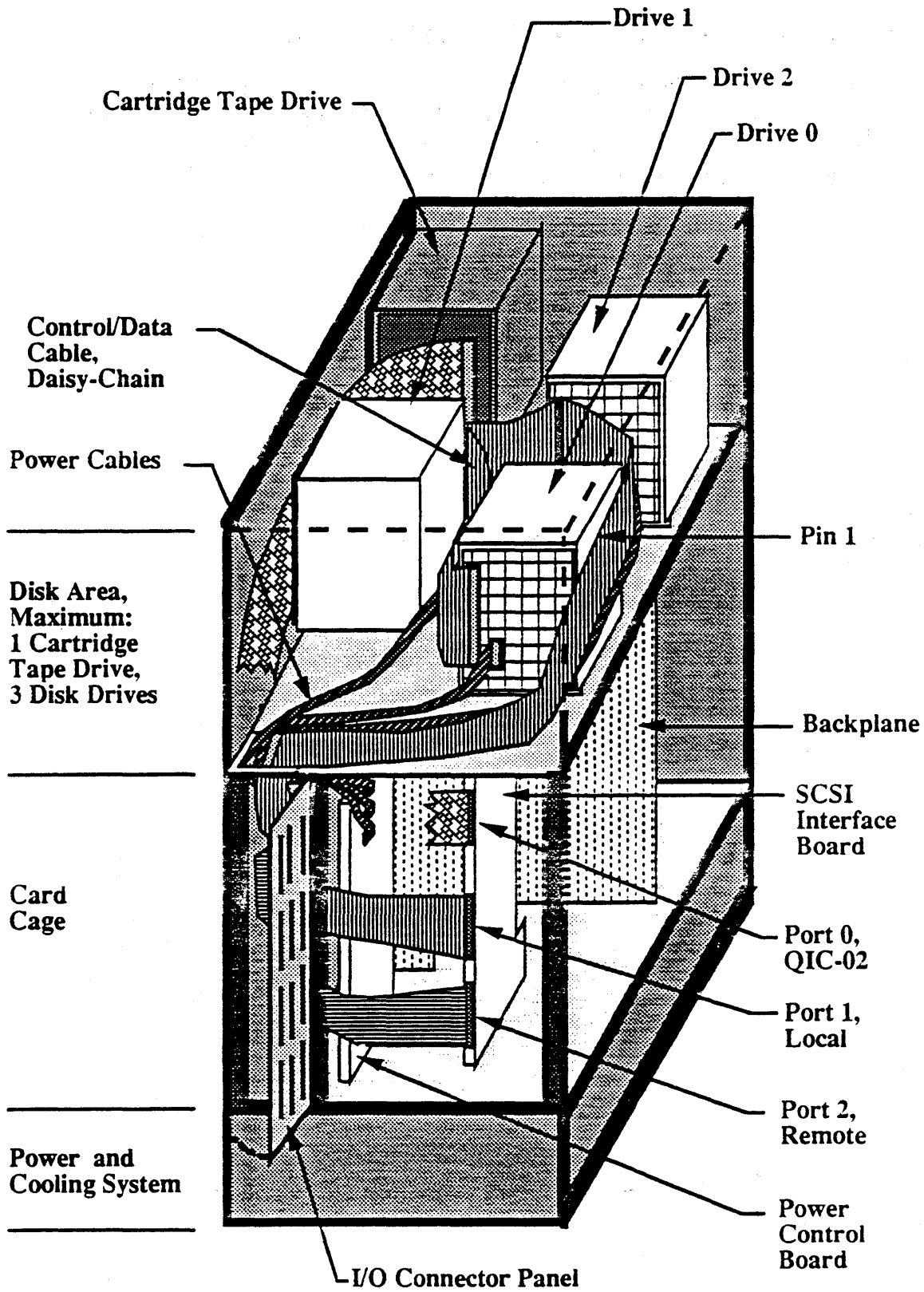

Figure 6-5. Vertical-Mount SCSI Drives

## INSTALLING A VERTICAL-MOUNT SCSI DISK DRIVE

Figure 6-6, *CDC 170 Mbyte SCSI Disk Drive Settings* and Figure 6-7 *CDC 380 Mbyte SCSI Disk Drive Settings*, are duplicate diagrams of the labels that attach to your SCSI drive. Use these diagrams in this procedure to configure your drive.

Before installing the drive, verify the drive configuration, as follows:

1. Configure the drives address: the address jumpers are labeled 4,2,1 on the 170 and 380 Mbyte drive. Define the disk drive's SCSI ID (address) as 0, 1, or 2 as necessary by installing the address jumpers, as follows:
  - Drive 0 -- No jumper in ID Select positions
  - Drive 1 -- Jumper the two vertical pins labeled 1
  - Drive 2 -- Jumper the two vertical pins labeled 2
2. Enable parity; install the P jumper.
3. Enable terminator power from the SCSI bus; install the terminator power jumpers (TP) as follows:
  - 170 Mbytes drive: jumper the upper two vertical pins farthest to the right of the jumper block .
  - 380 Mbytes drive: jumper the lower two horizontal pins in the jumper block next to the SCSI connector.
4. Isolate the power return from HDA and frame grounds:
  - 170 Mbytes drive: remove the second zero-ohm resistor (not necessary on ARIX supplied disk drives) on the lower circuit board under the power connector.
  - 380 Mbytes drive: install the CH ground jumper as shown in Figure 6-7.

### NOTE:

Drive 0 (D0) is the terminating drive; the last drive on the SCSI cable. Install the terminators on Drive 0 and remove the terminators on Drive 1 and 2.

Install a vertical-mount SCSI disk drive, as follows:

1. Install the following two cables (from the rear of the disk drive):
  - a. The 50-pin data/control ribbon cable. Note that pin 1 of the cable is up.
  - b. The 4-pin power cable. Note the orientation of the notch of the connector.
2. Align the two brackets that are attached to the drive to the screw holes on the upper edge of the side of the system the drive is being installed.
3. Replace the four phillips screws (two per bracket) that secure the disk drive to the side of the system.
4. Route the drive's cables as shown in Figure 6-5, *Vertical-Mount SCSI Drives*.
5. Replace the side panel: align the studs of the panel to the system and push until the panel snaps on.
7. Reassemble the system (refer to the previous section, *Internal Drive Storage Area*).

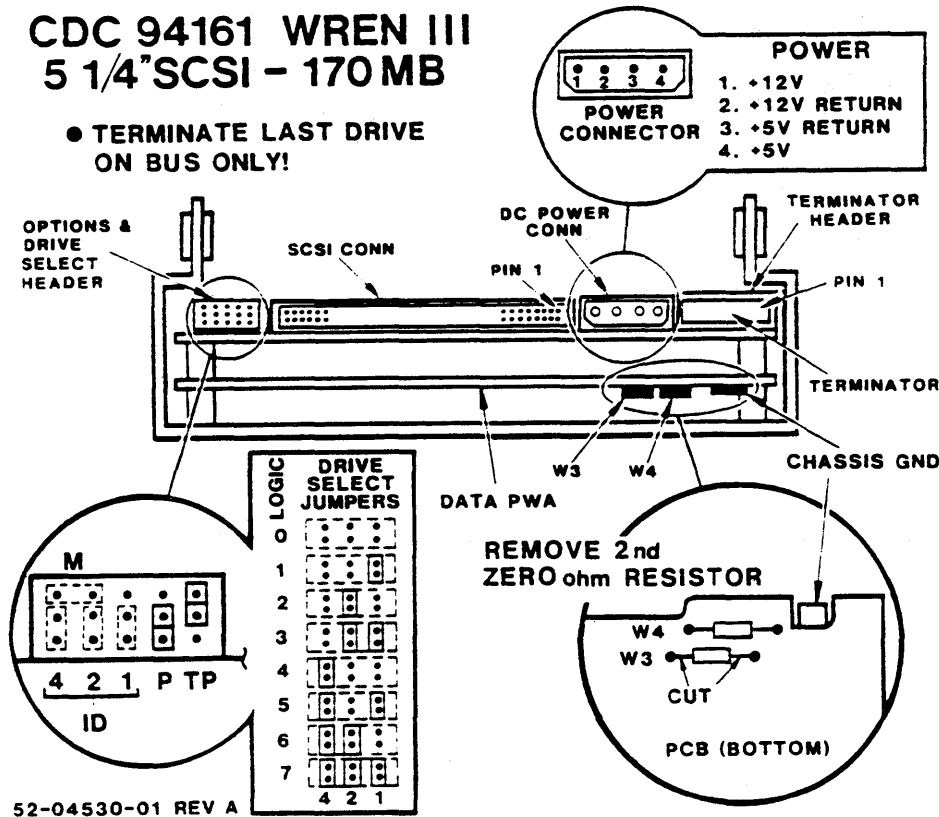

Figure 6-6. CDC 170 Mbyte SCSI Disk Drive Settings

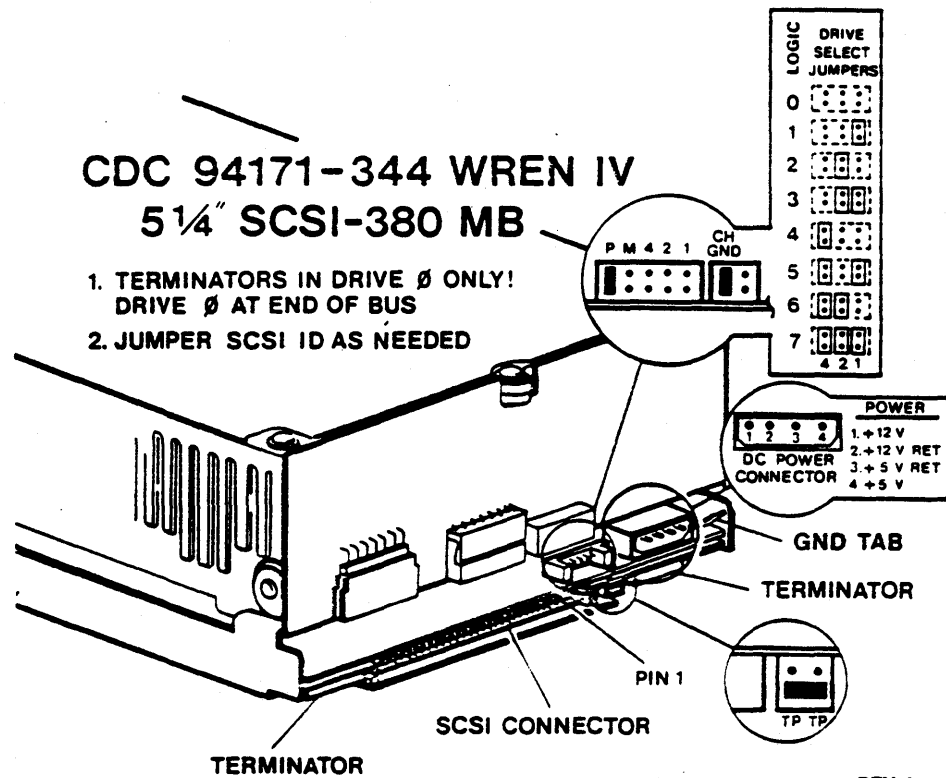

Figure 6-7. CDC 380 Mbyte SCSI Disk Drive Settings



## ***Horizontal SCSI Disk Drives***

This section describes removing or installing the horizontal-mount SCSI disk drives.

Figure 6-8, *Horizontal-Mount SCSI Drives*, is an internal view of the 825/800 with detail as to the placement of the SCSI drives, routing of the cables, connections to the SCSI interface board and the additional fan assembly.

Removal and installation of the SCSI drives require the disconnection/connection of the following two cables:

- **Data and Control Cable:** a 50-pin ribbon cable in a daisy-chain configuration that connects from drive 0 (always the terminating drive on the daisy-chain) to drive 1 to drive 2 and to port 1, Local, on the SCSI interface board.
- **Power Cable:** a 4-wire cable that provides power to the drive.

Prior to installing a horizontal SCSI drive, refer to installation procedure *IP-04410-XX, Rev. C*, for installation and upgrade requirements.

Horizontal disk drives are available only with the 825/800 systems that have the following part numbers:

- PS-825-23/24 (110 VAC) for 170 Mbyte disk drives
- PS-825-25/26 (220 VAC) for 380 Mbyte disk drives

The 23/24 code denotes the system voltage requirements: 23/24 requires 110 VAC and 25/26 requires 220 VAC.

### ***REMOVING A HORIZONTAL-MOUNT SCSI DISK DRIVE***

Remove a disk drive, as follows:

1. Label and remove the following two cables:
  - a. The 50-pin data/control ribbon cable. Note that pin 1 of the cable faces the front of the system.
  - b. The 4-pin power cable. Note the notch on the connector.
3. Remove the six phillips screws that hold the bracket (and the drive) to the system.
4. Remove the drive (with the brackets) from the system .

**INSTALLING A HORIZONTAL-MOUNT SCSI DISK DRIVE**

Figure 6-6, *CDC 170 Mbyte SCSI Disk Drive Settings* and Figure 6-7, *CDC 380 Mbyte SCSI Disk Drive Settings*, are duplicate diagrams of the labels that attach to your SCSI drive. Use these diagrams in this procedure to configure your drive.

Before installing the drive, verify the drive configuration, as follows:

1. Configure the drives address: the address jumpers are labeled 4,2,1 on the 170 and 380 Mbytes drive. Define the disk drive's SCSI ID (address) as 0, 1, or 2 as necessary by installing the address jumpers:
  - Drive 0 -- No jumper in ID Select positions
  - Drive 1 -- Jumper the two vertical pins labeled 1
  - Drive 2 -- Jumper the two vertical pins labeled 2
2. Enable parity by installing the P jumper.
3. Enable terminator power from the SCSI bus by installing the terminator power jumpers (TP) as follows:
  - 170 Mbytes drive -- Jumper the upper two vertical pins farthest to the right of the jumper block
  - 380 Mbytes drive -- Jumper the lower two horizontal pins in the jumper block next to the SCSI connector.
4. Isolate the power return from HDA and frame grounds, as follows:
  - 170 Mbytes drive -- Remove the second zero-ohm resistor (not necessary on ARIX -supplied disk drives) on the lower circuit board under the power connector.
  - 380 Mbytes drive -- Install the channel ground (CH) jumper.

**NOTE:**

Drive 0 (D0) is the terminating drive; the last drive on the SCSI cable. Install the terminators on Drive 0 and remove the terminators on Drive 1 and 2.

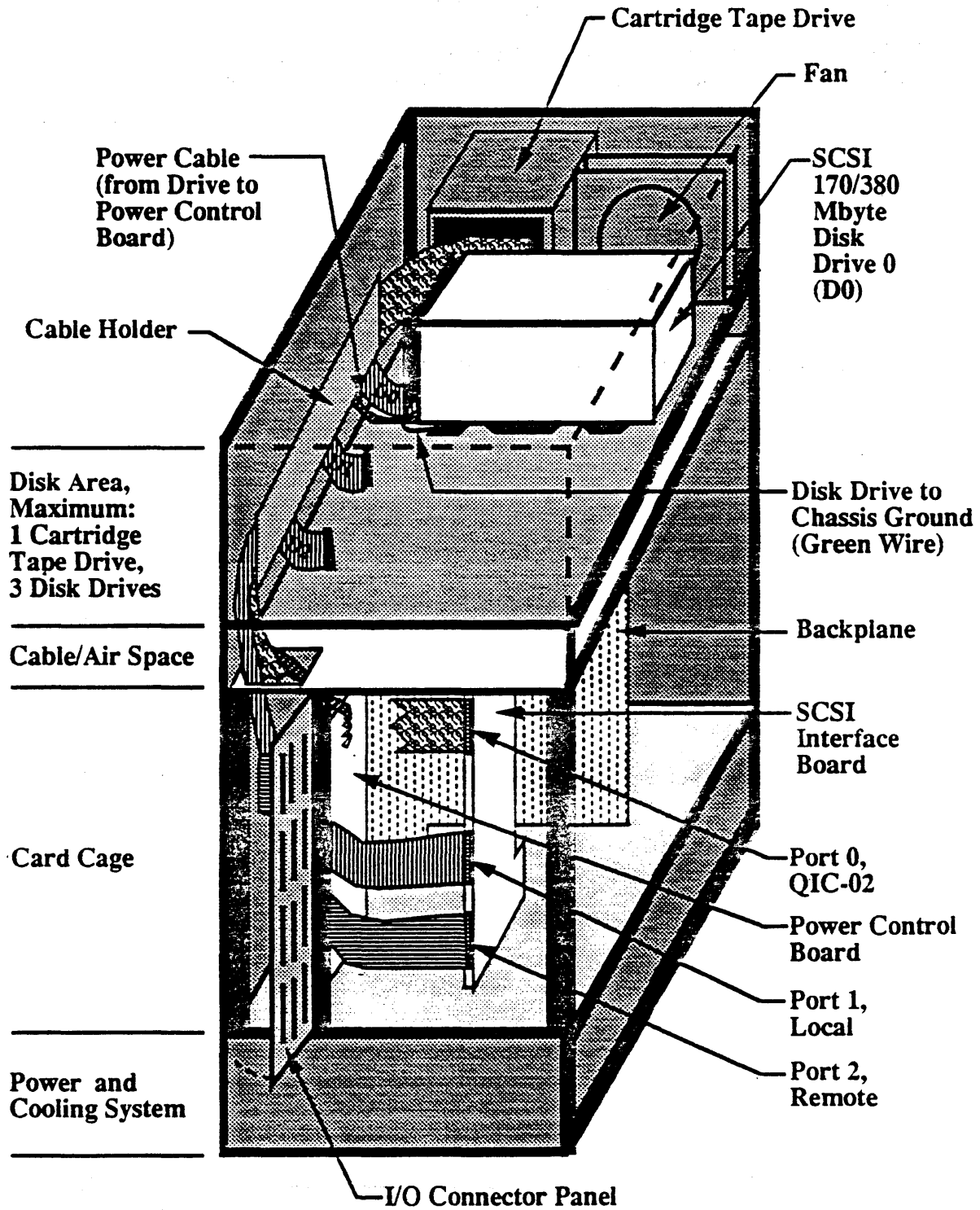

Figure 6-8. Horizontal-Mount SCSI Drives.

Install a horizontal-mount SCSI disk drive, as follows:

1. Place the SCSI drive into the mounting brackets. When the disk drive is secure in its mounting brackets, it is considered the SCSI drive assembly.
2. Fasten the drive to the bracket using the mounting screws, grommets, and bushings. Make sure that the thick end of each grommet goes against the disk drive.
3. Connect the ground wire to the tab on the drive and screw the opposite end of the wire into the threaded hole in the top bracket .
4. Mount the drive in the system at the appropriate location (as shown in Figure 6-8).
5. Connect the following two cables:
  - a. The 50-pin data/control ribbon cable. Note that pin 1 of the cable faces the front of the system.
  - b. The 4-pin power cable. Note the notch on the connector.

## **POWER SUPPLY ASSEMBLY**

This section provides the instructions to remove and install the power supply assembly. (Refer to Figure 6-1, *Internal Rear View*, and to Figure 6-2, *Internal Front View*.)

### ***Removing the Power Supply Assembly***

Remove the power supply assembly, as follows:

1. At the front of the system, remove the lower front cover: pull the cover up and out.
2. Under the left fan, label and remove the connector that is attached to the power supply: squeeze the connector tabs and pull out at the same time. Note the orientation of the keyed plug.
3. At the lower rear of the system, remove the lower air vent: remove the phillips screws that secure the air vent to the system. Save the screws.
4. Remove the I/O connector panel: from the left rear of the system, remove the phillips screws that secure the panel. The door opens to the right.
5. Inside the I/O connector panel to the left, label and remove the 12-pin connector (P1) from the bottom right of the power control board.
6. Label and remove the 15-pin connector (P2) from the bottom middle of the power control board.
7. Label and remove the orange (E2) cable (power) from the rear of the motherboard.
8. Label and remove the +5V sense cable (P3) from the rear of the motherboard.
9. Label and remove the black cable (E1, ground) from the rear of the motherboard.
10. At the front of the system underneath the fans, remove the two phillips screws located at the front of the power supply. Save the screws.
11. At the rear edge of the system, remove the two phillips screws that attach the power supply tray assembly to the system.
12. At the rear of the system, ensure that the leveling feet do not protrude up into the power supply assembly tray. If they do, raise the leveling feet on the system until the tray can be removed. (Refer to Section 2, *Main Cabinet Installation*.)
13. From the rear of the system, carefully slide the power supply assembly tray forward and out.

## ***Installing the Power Supply Assembly***

Install the power supply assembly, as follows:

1. Verify that the power supply and selector switch are set to the proper voltage.
2. Ensure that the leveling feet do not protrude up into the power supply assembly tray.
3. With the connections towards the rear, slide the power supply assembly tray into the rear of the system.
4. Align the power supply assembly tray to the holes in the bottom of the system.
5. Route the orange (E2), black (E1), and +5 sense cables around the left of the power supply control board to the motherboard.
6. At the rear of the system, secure the power supply assembly tray to the system using the two phillips screws located at the rear edge of the system.
7. At the front of the system, secure the power assembly tray to the system using the two phillips screws located under the fan assembly.
8. Replace the bolt that secures the orange (E2) cable to the motherboard.
9. Attach the +5 sense cable to the motherboard and verify it is firmly in place.

### **CAUTION:**

**If the +5 sense cable is not properly installed, damage to the system may occur.**

10. Replace the bolt that secures the black (E1) cable to the motherboard.
11. Route the 15-pin connector (P2) up towards the power supply control board and connect it to the bottom middle connector.
12. Route the 12-pin connector (P1) up towards the power supply control board and connect it to the bottom right connector.
13. Close the connector panel door, and secure it to the system using the four phillips screws.
14. At the lower rear of the system, secure the lower air vent to the system using the phillips screws.
15. Attach the connector (under the left fan) that attaches to the power supply.
16. Replace the lower front cover of the system by aligning the metal grooves to the holes (below the upper front cover) and pushing in.

## POWER SUPPLY VOLTAGE SETTING

This section describes accessing and changing the voltage setting of the power supply. ARIX configures the system at the factory for either 110 or 220 VAC operation.

### WARNING:

**This procedure must only be performed by ARIX-trained personnel.**

From the front of the ARIX 825/800, change the voltage setting, as follows (refer to Figure 6-9, *Power Supply, Front View*):

1. Remove the lower front cover: pull the cover bottom out and pull the cover down.
2. Loosen the voltage setting cover: below the fans and in the center of the power supply is a small metal plate (the voltage setting cover) secured by two phillips screws. Loosen (do not remove) these two screws.
3. Flip the voltage setting cover to the right to access the voltage setting circular switch.
4. Change the voltage setting: the switch is stamped 110 and 220; a notch shows which voltage the switch is set to. Place a #3 flathead screwdriver in the switch slot provided and turn the switch so that the notch and voltage setting align.
5. Flip the voltage setting cover back over the switch and tighten the two phillips screws.
6. Replace the lower front cover of the system: align the metal grooves to the holes below the upper front cover, slip the cover up and push the bottom in.

From the rear of the system, change the main supply switch, as follows (refer to Figure 6-10, *Power Supply, Rear View*):

1. Remove the lower air vent: remove the seven #2 phillips screws that secure the lower air vent to the system. Save the screws.
2. Remove the yellow plastic plate that covers the terminal block: push one tab in and gently pull one side of the plate out. Continue until all four tabs are released and remove the yellow plate.
3. Change the position of the voltage selection jumper: a metal jumper is secured either to 110 or 220. Loosen the flathead screws that secure the metal jumper to the terminal block.
4. Move the metal jumper to the voltage position you need and tighten the three screws.

5. Replace the yellow plastic plate: align the plate to the tabs and push in near the tabs.
6. Mark the new system voltage on the configuration label located near the bottom-rear of the system on the power supply tray.
14. Secure the lower air vent to the system. Use the phillips screws.
15. Change the AC power plug to accommodate the new voltage setting.

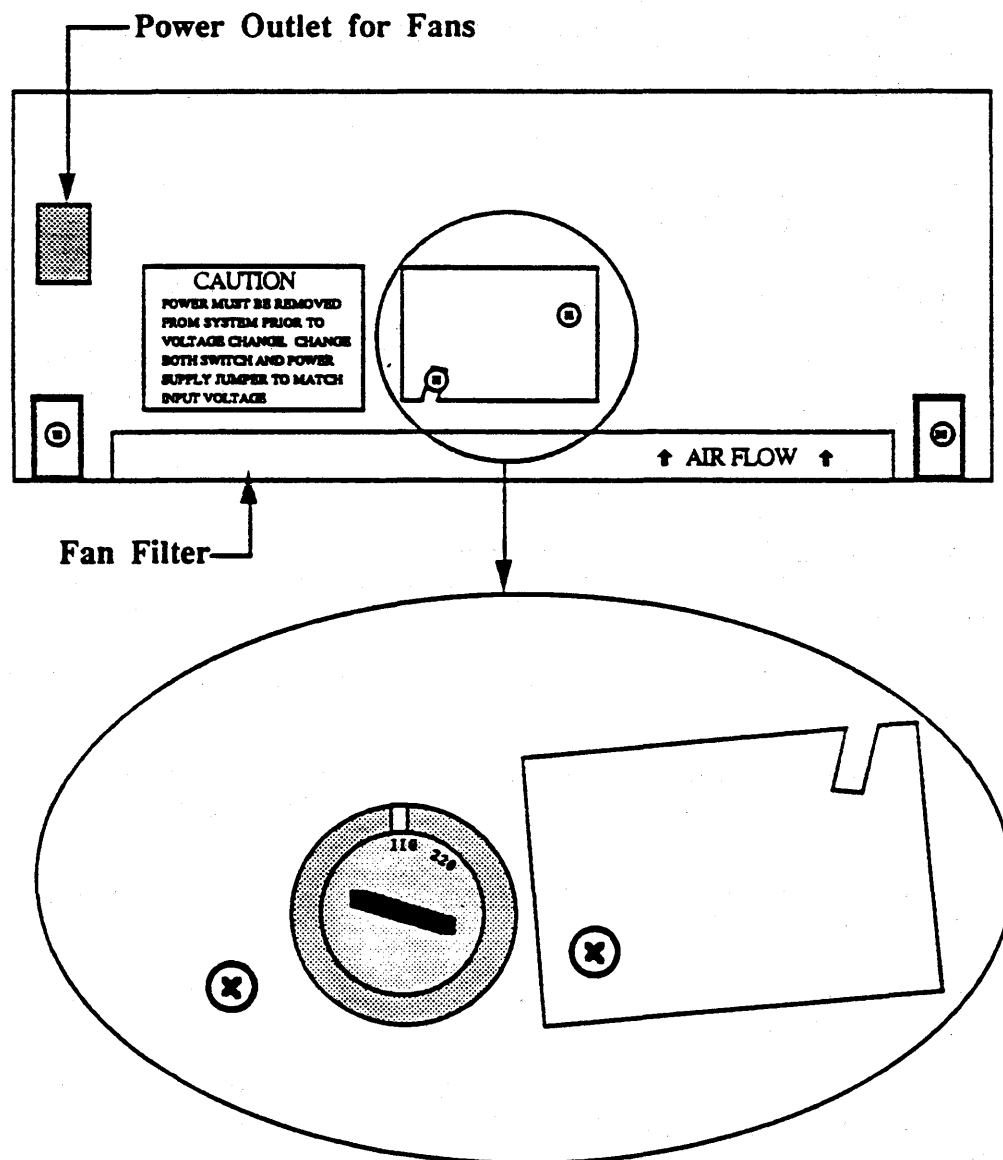

Figure 6-9. Power Supply, Front View



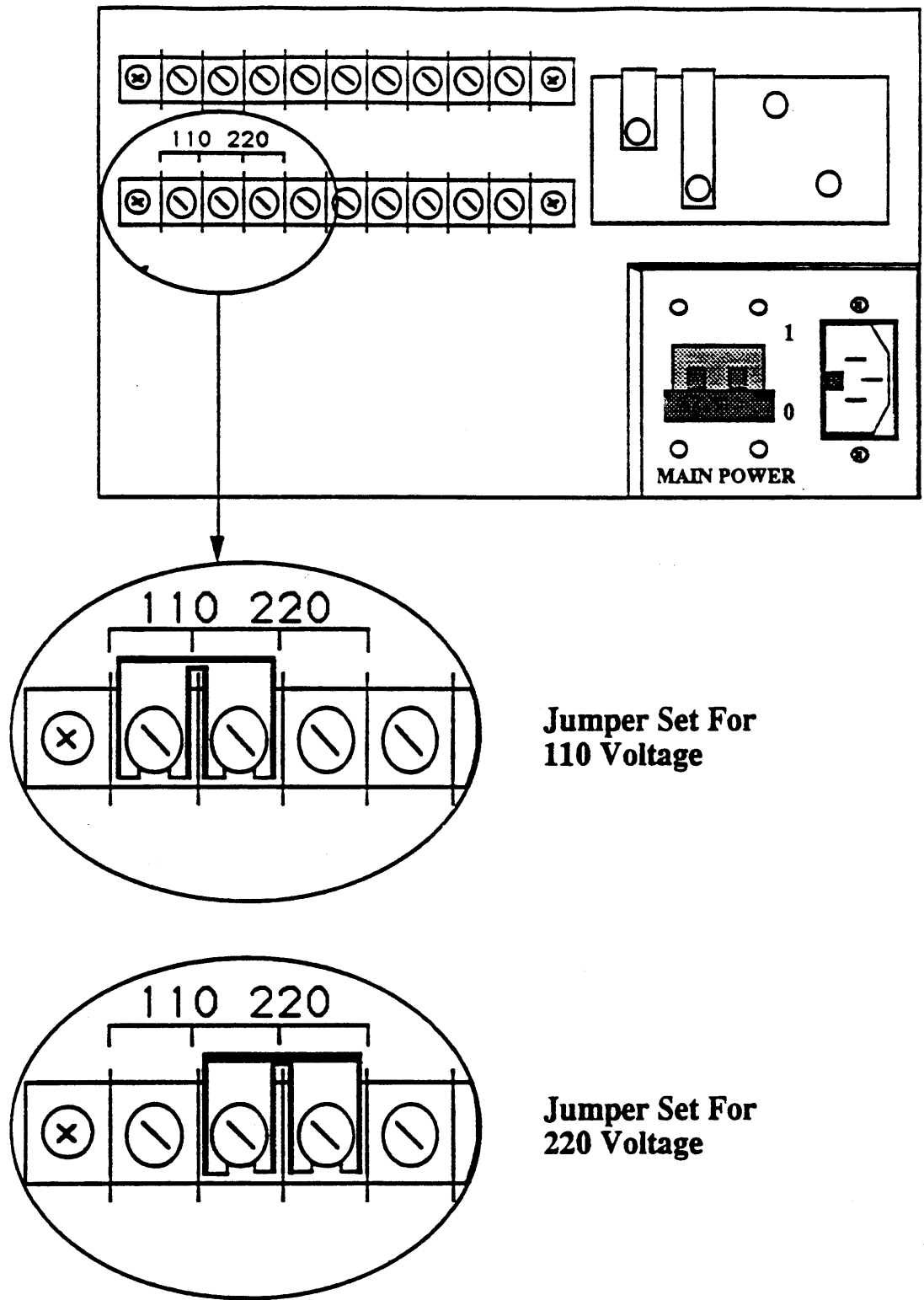
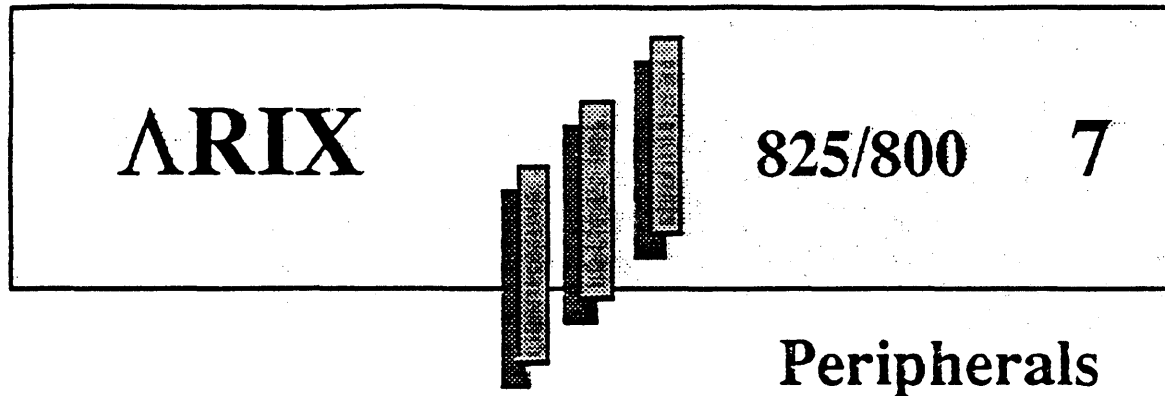

Figure 6-10. Power Supply, Rear View





This section describes the installation and the operating requirements of optional peripherals that connect externally to an 825/800 system.

This section describes the following:

- Expansion cabinet capabilities (refer to Table 7-1, below)
- Cartridge Tape Drives
- 8- and 5 1/4-inch disk drives
- SCSI Optical disk drives
- Disk Array Module (SCSI disk drives)
- Modular Communications Processor (MCP; a stand-alone unit)

Use shielded communication cables in all installations.

**Table 7-1. 825/800 Expansion Cabinet Maximum Capacities**

Maximum Number of Cabinets	9-Track Tape Drives	5 1/4-inch Disk Drives	8-inch Disk Drives	SCSI Disk Array Modules	SCSI Optical Disks
One Exp. Cabinet	1	4	4	2	3
Two Exp. Cabinets	2	8	8	4	6

## EXPANSION CABINET

The expansion cabinet houses the peripheral disk and tape drives and is wider than the Model 825/800 cabinet. The disk, 9-track tape, and optical disk drives can be arranged in a variety of configurations to meet your specific needs.

To make it easier to interconnect the various peripheral devices, special expansion cabinet connectors are provided on the lower back doors of both the expansion cabinet and the system cabinet. (Refer to Figure 7-1, *Expansion Cabinet*, and Figure 7-2, *Expansion Connector Panel*.)

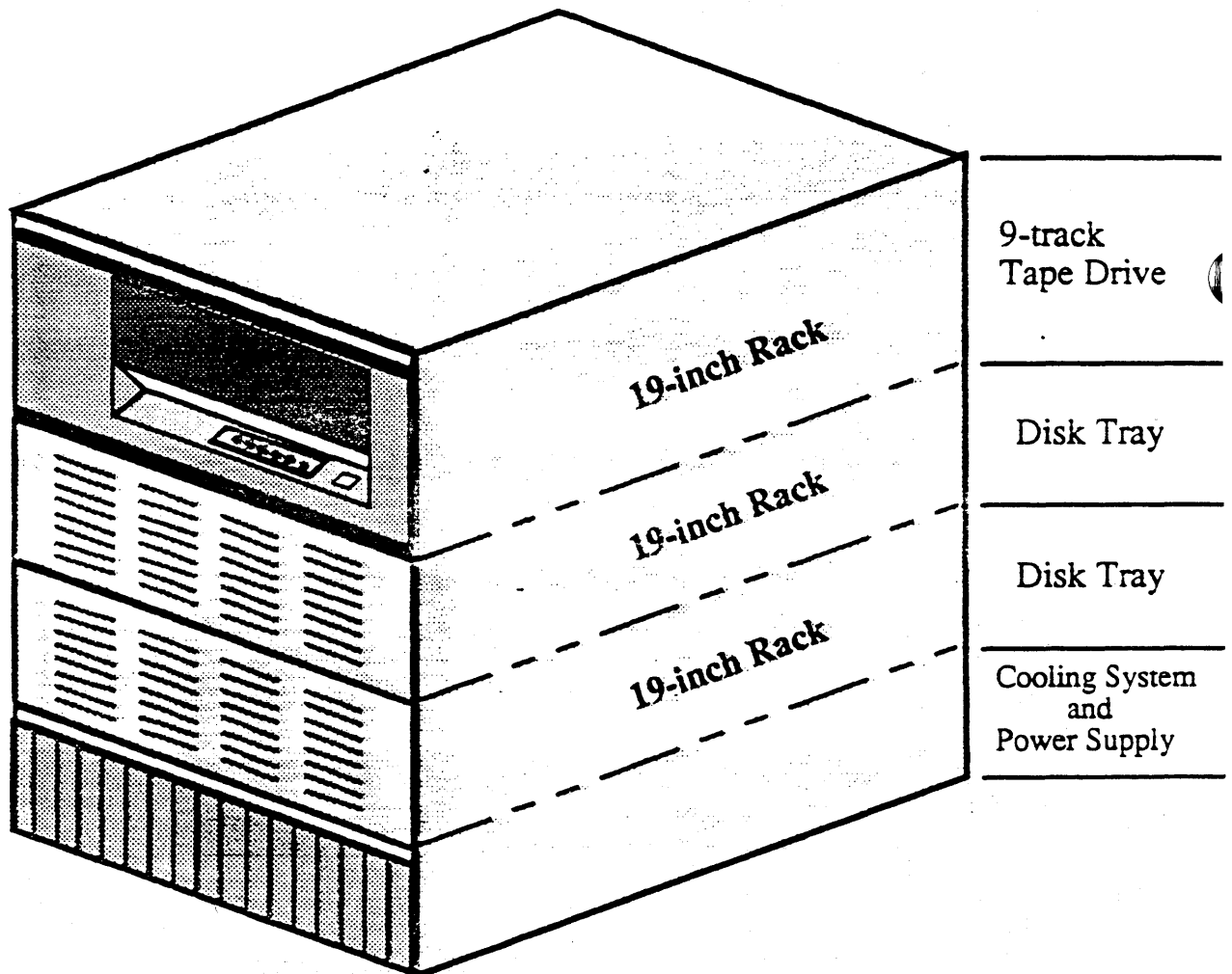

Figure 7-1. Expansion Cabinet

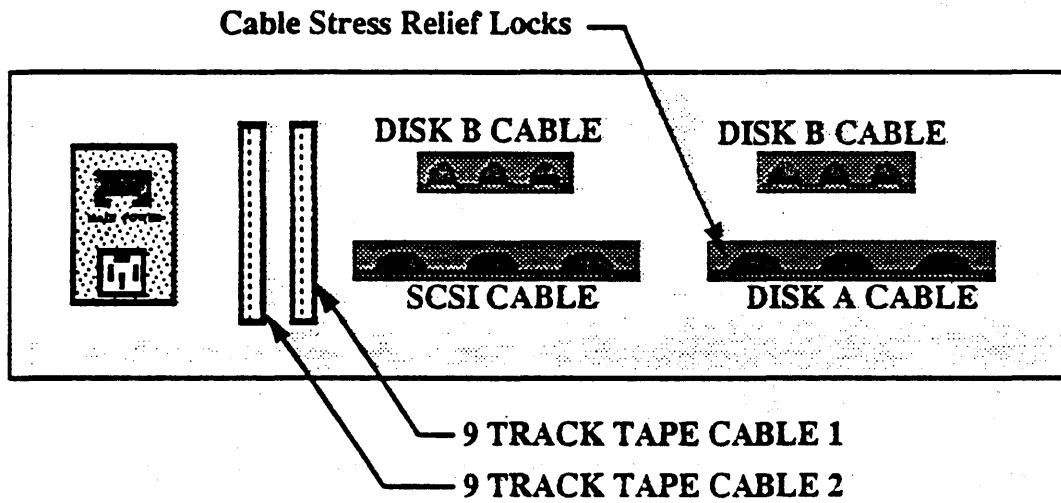

Figure 7-2. Expansion Connector Panel

## ***CARTRIDGE TAPE DRIVES***

The ARIX 825/800 systems use the cartridge tape drive for system backup, software distribution, transaction logging, data collection, data exchange, and program loading.

ARIX supports the Archive and the Wangtek tape drive, however, the Wangtek is no longer available.

ARIX uses the QIC-02 interface for all tape drive connections.

### ***Archive Viper Cartridge Tape Drives***

The Viper is a half-height 1/4-inch cartridge streaming tape drive that supports data transfer burst rates of up to 1.8 Mbytes per second using the QIC-02 interface.

Refer to Figure 7-3, *Archive Viper Tape Drive (Front View)*.

### ***Wangtek Cartridge Tape Drives***

The Wangtek tape drive is a full-height cartridge streaming tape drive that supports QIC-02 interface. The Archive has replaced the Wangtek in the 825/800 systems, however, ARIX will continue support of this product.

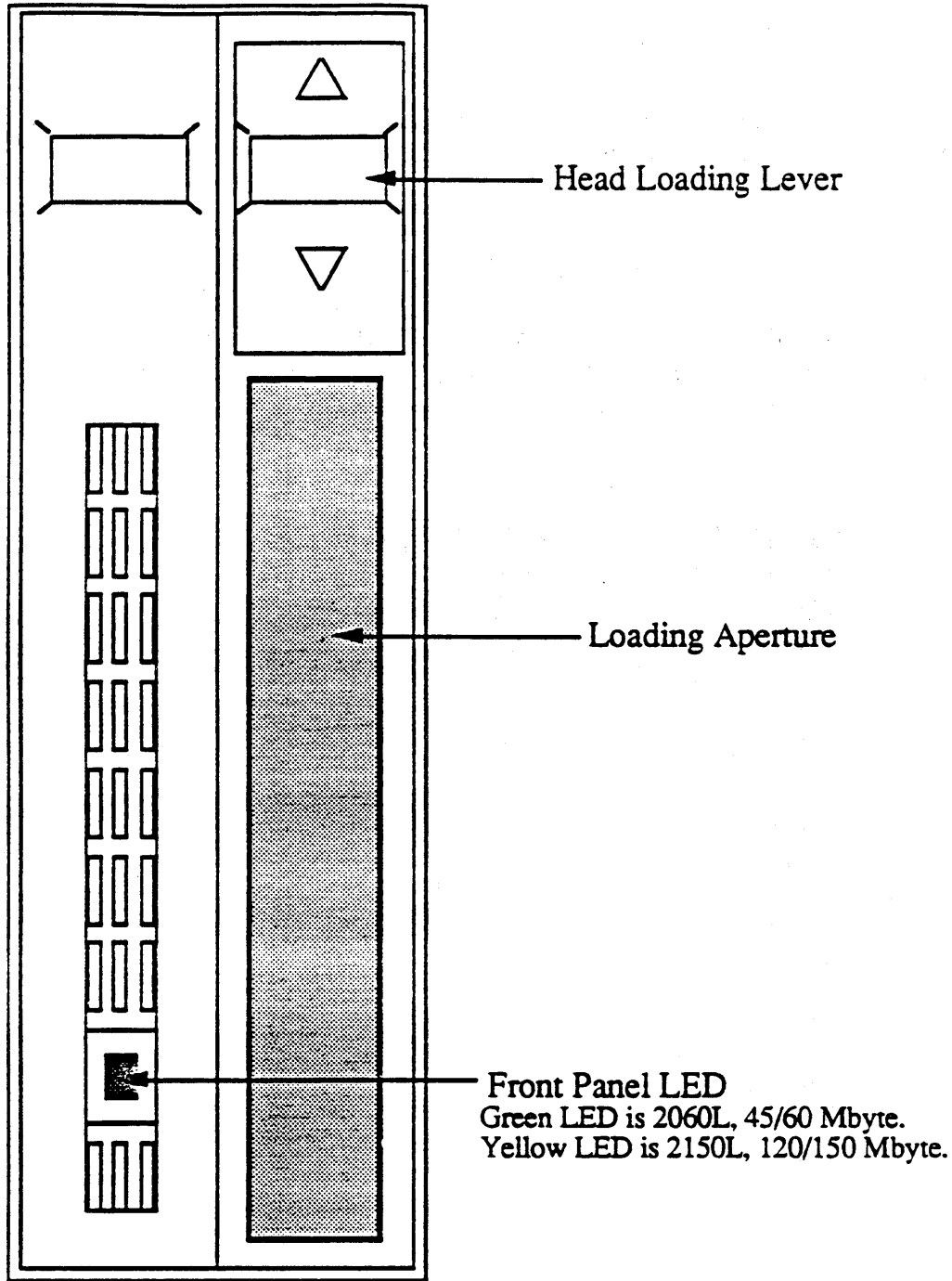

Figure 7-3. Archive Viper Tape Drive (Front View)

## 9-TRACK OPERATION

This subsection explains the ARIX device numbering scheme, and the operation procedures for the Cipher 9-track tape drive.

### 9-Track Device Numbering Scheme

Before accessing the Fujitsu or Cipher 9-Track Tape Drives, become familiar with the ARIX "Device Numbering Scheme" for 9-track tape drives. Table 7-2 lists the devices located in /dev/9mt for the 9-track tape drives.

Table 7-2. 9-Track Tape Drive Devices

Device Name	Device Type	Major Device	Minor Device
c0d0m	c	20	64
c0d0h	c	21	72
c0d0mn	c	20	0
c0d0hn	c	21	8
c1d0m	c	20	80
c1d0mn	c	20	16
c1d0ms	c	20	208
c1d0mns	c	20	144
c1d0mc	c	20	84
c1d0mcn	c	20	20
c1d0mcs	c	20	212
c1d0mcsn	c	20	148
c1d0h	c	20	88
c1d0hn	c	20	24
c1d0hs	c	20	216
c1d0hns	c	20	152
c1d0hc	c	20	92
c1d0hcn	c	20	28
c1d0hcs	c	20	220
c1d0hcsn	c	20	156

The devices in Table 7-2 provide that the 9-track tape drive connects to controller number 1 (c1) of the ARIX Model 825/800.

Tape drives that do not write burst ID's in high-density mode (Cipher 3200 bpi) are assigned a major number of 21. If the 9-track is the second device on controller number 2, then the device prefix would be c2d1.

The 9-track minor device numbers were determined from the bit map in Table 7-3.



**NOTE:**

All 9-track tapes distributed from ARIX are written at 1600 bits-per-inch (bpi).

**Table 7-3. 9-Track Bit Map**

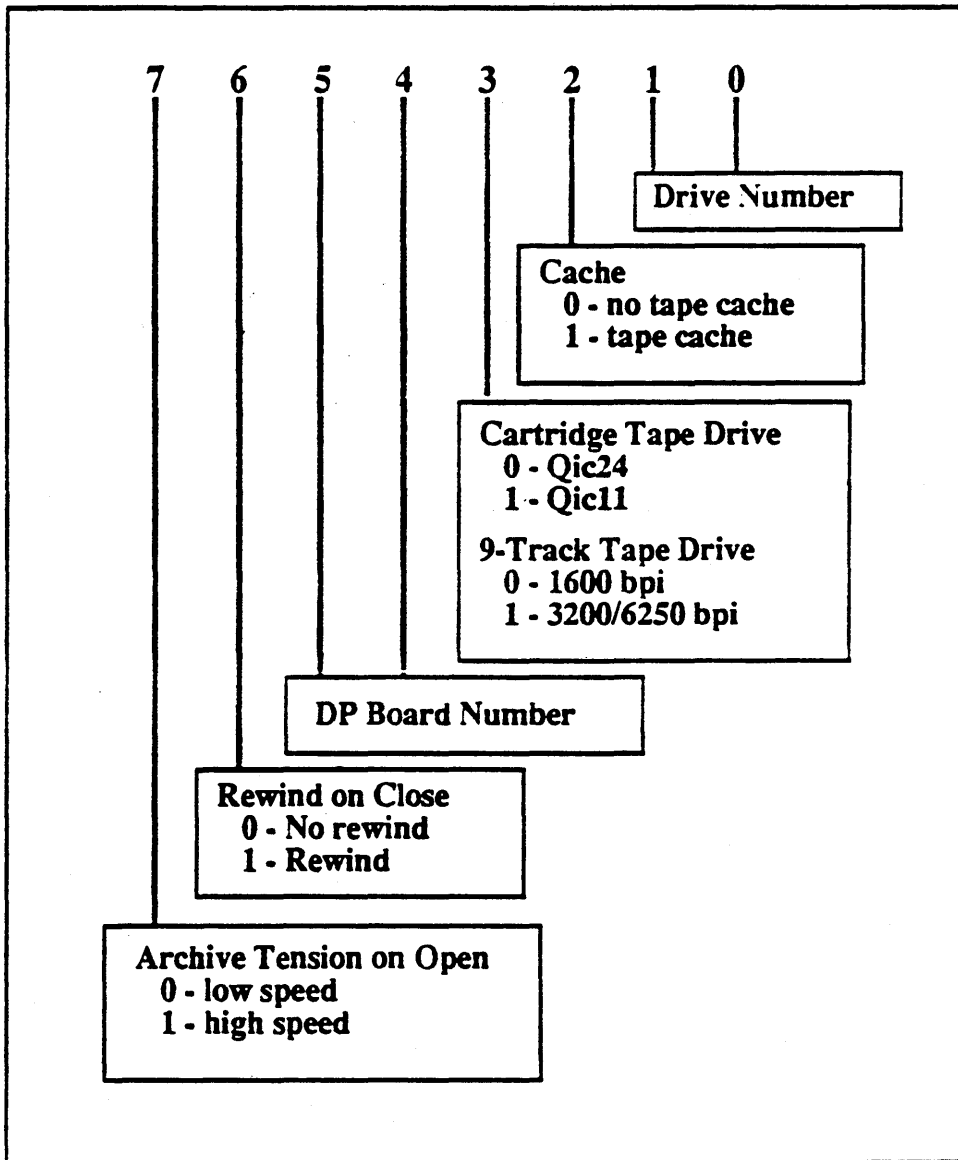

The post-fix to the controller and device specification (c1d0xxxx) represent options for density, speed, rewind on close, and cache utilization (refer to Table 7-4, *9-Track Options*).

Table 7-4. 9-Track Options

n = no roc(rewind on close)
m = medium density 1600 bpi for Cipher 1600 bpi for Fujitsu
h = high density 3200 bpi for Cipher 6250 bpi for Fujitsu
s = high speed 75 ips for Cipher 75 ips for Fujitsu
c = cache enabled

## Cipher 9-Track Operation

The 9-track tape drive requires two 50-pin cables that connect the control and data transfers. You can add an additional drive by one of the following methods:

- Link each drive together in a daisy-chain (cascaded) configuration which decreases performance.
- Add an additional controller for the new drive which increases performance. ARIX recommends this configuration for each additional drive.

Power up the unit by pressing the POWER switch (on the front of the unit) to the ON position (refer to Figure 7-4, *Cipher Control Panel*).

When the unit is powered ON, all of the lights on the front panel will flash on and off, and the UNLOAD light will remain illuminated.

The 9-track tape drive automatically runs Power-On diagnostics. If fault occurs during Power-On diagnostics, generally indicated by one or more blinking lights, call an ARIX Service Representative.

When the tape drive has successfully passed the Power-On diagnostics, a tape is ready to be loaded, as follows:

1. Open the plastic door on the front of the tape drive, insert a tape on the inside bottom hub, and then close the door.
2. Press the LOAD button. The tape automatically loads onto the take-up reel.
3. When the LOAD light stops blinking, press the ONLINE button. The tape drive is now on-line.

The tape drive is now ready to be accessed by the ARIX system.

**NOTE:**  
If there are any tape errors, clean all the surfaces that make contact with the tape. (Refer to Section 8, *Preventative Maintenance*).

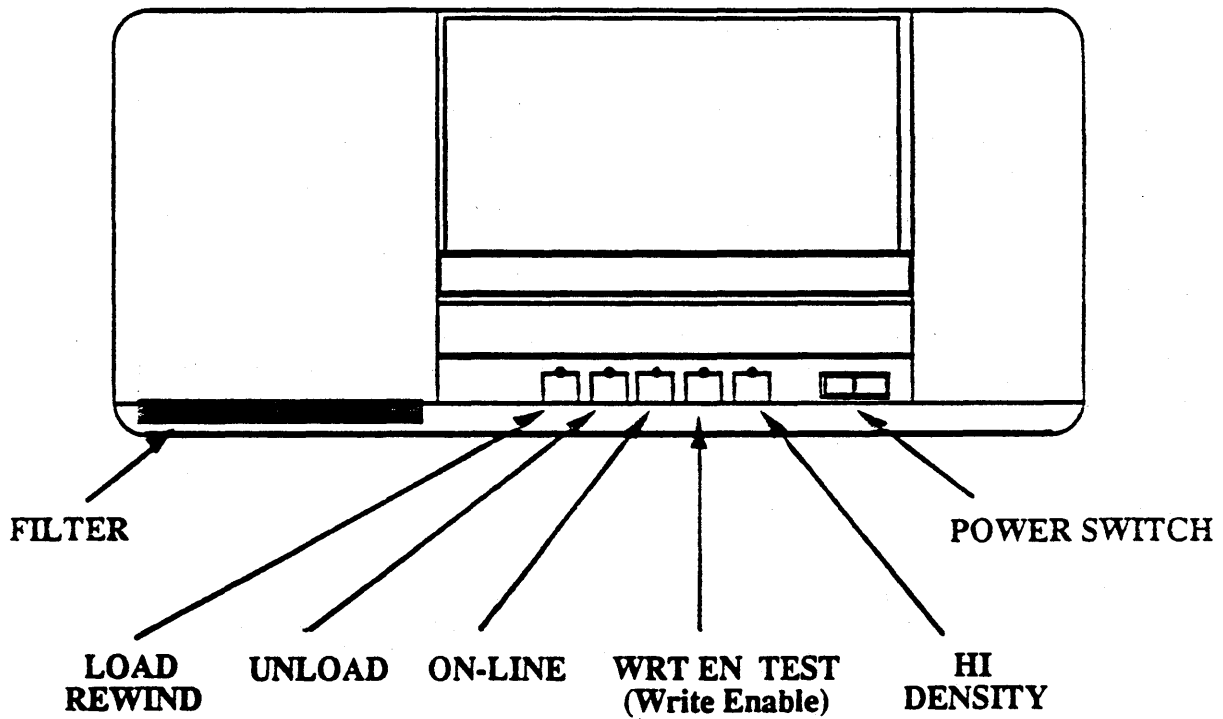

**Figure 7-4. Cipher Control Panel**

## ***DISK DRIVES***

The ARIX Model 825/800 supports many different disk drives, as follows:

- SMD 170, 337 and 824 Mbyte
- HSMD 337 and 824 Mbyte
- SCSI 170 and 380 Mbyte

Mixing SMD and SCSI disk drives is not supported. Contact your ARIX Sales Representative or Customer Support for more information. Also refer to Section 6, *Subassembly Removal And Installation* in this manual.

### ***SCSI Optical Disk Drives***

The ARIX optical disk subsystem uses the OSI Laser Drive LD-1200. The optical disk is a write-once-read-multiple (WORM) device that stores 1 Gbyte on each side of a 12-inch diameter removable platter (one side is used at a time).

Each drive has its own internal controller with a SCSI interface and communicates to a SCSI-Multibus host adapter in a Multibus Adapter Card (MAC). The MAC resides in one of the IOCP slots in the system cabinet.

For additional information about the optical disk, refer to the *ARIX Optical Disk Hardware Installation Procedure* (IP- 99257-00) and the *ARIX Optical Disk Software Installation Procedure* (IP-99256-00).

### ***Fujitsu Disk Drives***

The Model 825/800 supports both Fujitsu 5 1/4-inch and 8-inch diameter SMD and HSMD disk drives. Each disk drive requires a 26-pin control and a 60-pin data cable for proper operation. The control cable connects directly between the EDT and the disk drive. The data cable connects from the EDT to all drives in a daisy-chain configuration.

An 825/800 that uses both internal and external disk drives must use two EDT controllers (the first controller supports only the internal drives and the second controller supports the external drives in the expansion cabinet).

## ***SCSI Disk Drives***

The Model 825/800 supports up to ten 170 or 380 Mbyte SCSI 5 1/4-inch disk drives (three internal and seven external SCSI drives). The advantage to SCSI is intelligent data control on the bus between each drive and the SCSI board. Having more than one disk drive in your system improves overall system performance, by the inherent SCSI design.

One 50-pin cable connects from the SCSI interface board to all SCSI drives in a daisy-chain configuration.

## MODULAR COMMUNICATIONS PROCESSOR

The ARIX Modular Communications Processor (MCP) is a data communications subsystem that expands one synchronous serial data port of the GC/EGC/GC16 interface board into 16 asynchronous serial data ports (refer to Figure 7-5, *MCP Connections*).

ARIX supports the MCPs, but no longer sells the MCP.

The UNIX interface to the MCP is provided by a device driver installed in an ARIX system. The device driver provides a standard tty device interface to the MCP (called *ttm*), provides no compatibility problems with existing software applications or ARIX commands and utilities. For instructions on loading the software for the MCP, refer to the *ARIX Modular Communications Processor (MCP) Software Release Notes*.

### MCP Installation

The instructions to install the MCP to an ARIX system are, as follows:

1. Place the MCP on top of the expansion cabinet .
2. Plug in the MCP AC power cord to a power outlet.
3. Connect "Trunk 1" on the MCP to Port 0 or Port 1 of the GC interface board. (The GC/EGC/GC16 supports 2 MCPs, the first would be connected to Port 0 and the second to Port 1).
4. Connect terminals to the 16 ports on the MCP(s) (Port 0 through Port 15).

The MCP(s) will automatically set the baud rate on the port to match the terminal (up to 19,200) after the terminal drops and raises DTR (power off and on or disconnect and connect) and sends one or more carriage returns.

The terminal speed as reported by *stty* may not be the actual operating baud rate of the terminal. Also, because the MCP (versus the GCP) is responding to flow control, the *stty* parameter (*ixany*) is not effective.

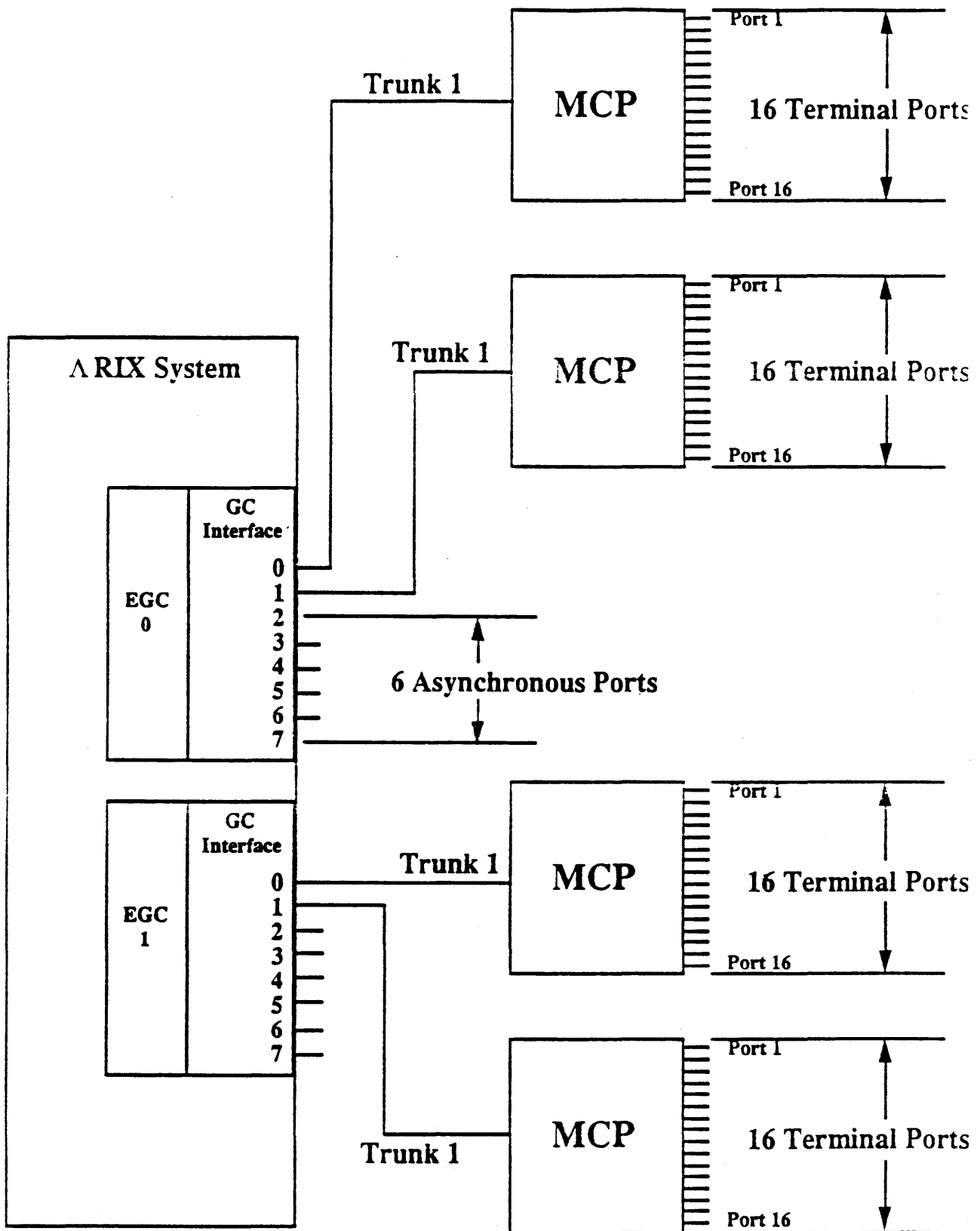
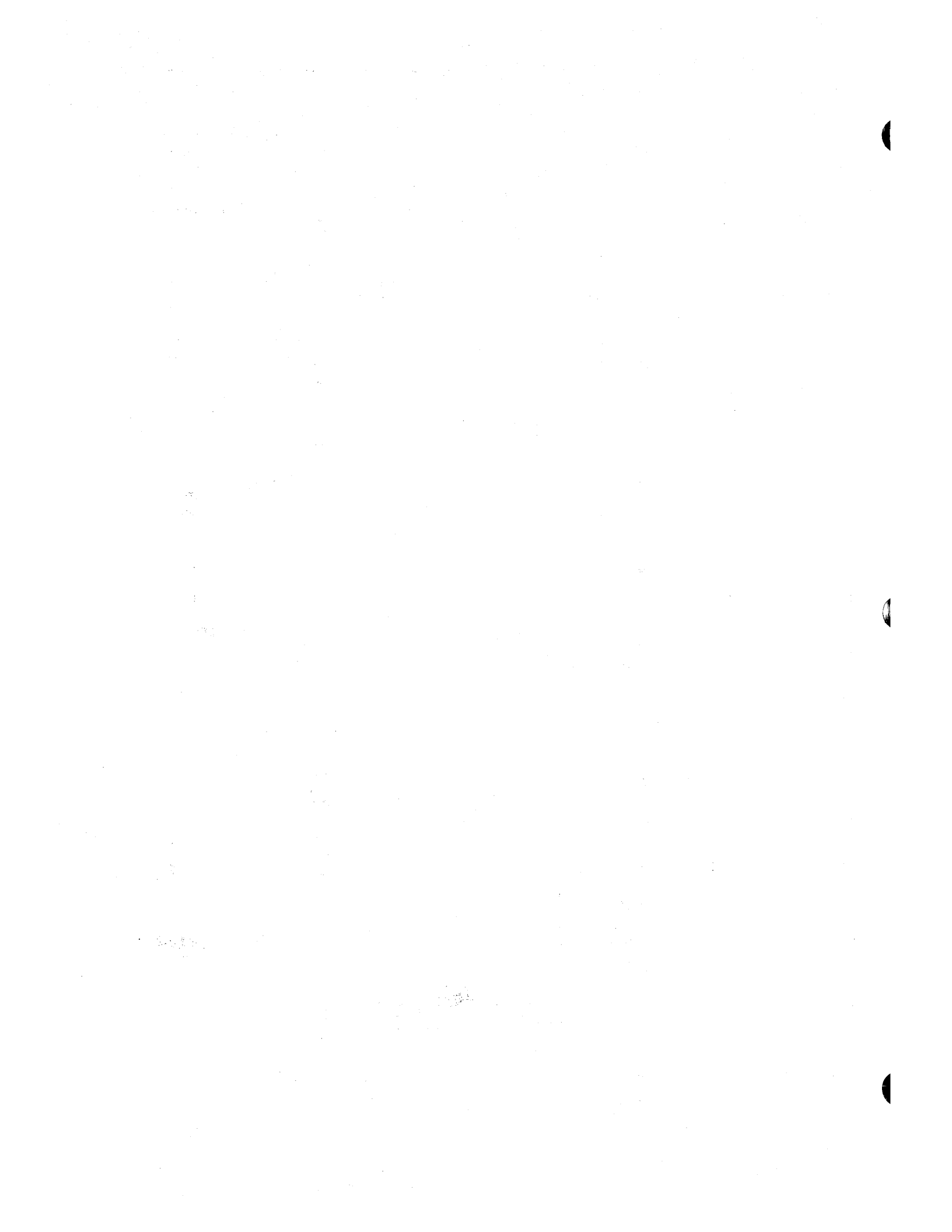
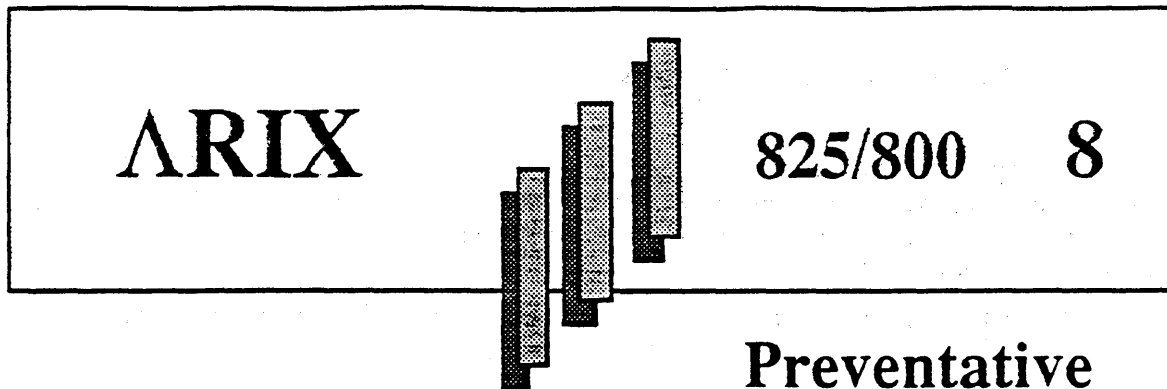

Figure 7-5. MCP Connections







## Preventative Maintenance

This section describes Preventative Maintenance (PM) procedures for the ARIX system fan filters, cartridge tape drive, 9-track tape drive and system exterior maintenance.

The following tools are used in PM procedures:

- Lintless cotton swabs in 3-inch and 6-inch lengths
- Head- or tape-cleaning solution; Freon TF or IBM Tape Cleaner
- Clean soft brush
- Lint-free cloth
- Compressed air or low pressure air in an aerosol can

Throughout this section, references to using the cotton swabs to clean components means to use swabs dampened, not soaked or dripping, in freon TF or IBM tape cleaner fluid.

### *SYSTEM EXTERIOR*

Clean the exterior of the main cabinet with a soft cloth moistened with a mild detergent.

## **SYSTEM FAN FILTERS**

The ARIX system uses internal fans for heat transfer and to maintain airflow throughout the system. Prior to entering the system, two air filters clean the air. One filter is attached to the removable bottom front panel. The other filter is attached to the front of the system below the fan assembly.

Clean the system air filters once a month. If the system is located in an area that is environmentally unstable, clean the filters once a week.

Remove and clean the system fan filters, as follows:

1. Remove the bottom front panel from the system: at the front of the system, grasp the lower panel, pull out until the bottom pops off, then down on both sides.
2. Slide the filter that is attached to the bottom front panel out of its frame.
3. Reach under the front of the system cabinet and pull the filter forward until it comes out.
4. Rinse both filters with water until clean and dry them thoroughly.
5. Slide the bottom front panel filter back into its frame.
6. Slide the filter that goes under the fans back in with the label "↑ Air Flow ↑" facing the front of the system with the arrows pointing up.
7. Replace the bottom front panel: align the metal tabs to the slots in the chassis under the top panel. Gently push inward until the ball studs reseal in their capture holes.

## **CARTRIDGE TAPE DRIVES**

The ARIX 825/800 systems use the cartridge tape drive for system backup and loading new or updated software. The tape drive must be part of a regularly scheduled maintenance program.

Contamination of the head and/or sensors inhibits the performance of the tape drive. Each drive has its own maintenance requirements.

Throughout this section, a swab refers to a lintless cotton swab that has been dampened, not soaked, with Freon TF or IBM Tape Cleaner

Operating time between maintenance procedures for the head and sensors are dependent upon the manufacturer of the tape drive.

## Archive Viper Cartridge Tape Drives

The Viper drive cleaning schedule is, as follows:

- Clean the recording head:
  - After each initial pass from a new tape cartridge
  - After every eight hours of read, write, or erase activity
- Clean the sensor openings and cartridge cavity whenever dirt or dust become visible

Clean the Viper cartridge tape drive, as follows:

1. Remove power from the drive (refer to Section 3, *System Startup And Shutdown*, subsection, *Power Removal*).
2. Visually inspect the interior of the drive. If contamination is visible in the sensor holes or within the cartridge cavity of the drive, use low pressure air to carefully blow out dust or debris from these areas.
3. Moisten the spade end of a swab with head-cleaning solution.
4. Slide the cartridge loading lever toward the cartridge insertion aperture until you can see the heads extend into the cartridge cavity.
5. Carefully wipe the swab across the heads in the direction of tape travel.

### NOTE:

Be careful when cleaning the tape heads. Do not wipe the heads in a direction that is perpendicular to tape movement and do not use a scrubbing, circular motion.

6. Discard the first swab; moisten a second swab with head-cleaning solution and repeat the wiping motion until all residue has been removed from the head surface.
7. Discard the second swab. Use a clean dry swab and wipe the head in the direction of tape travel until the head is clean and dry.
8. Slide the cartridge loading lever away from the cartridge insertion aperture until you can see the head assembly return to its position.

## Wangtek Cartridge Tape Drives

Clean the magnetic head after two hours of use with a new tape cartridge, and every eight hours of use after that.

### CAUTION:

**When cleaning the tape drive, ensure that the cleaner or the swab does not drip on any of the other parts in the tape drive.**

Maintain the components within the cartridge tape drive, as follows:

1. Access the tape drive head assembly: push the black tape retainer bar (on the inside of the tape drive against the left) in until the bar pops forward. The head assembly and drive wheel will pop down when the retainer bar pops forward.
2. Clean the head assembly: the head assembly is a 1-inch by 1/2-inch brass piece located at the top middle of the drive. Use a swab moistened in head-cleaning solution and dab the tape head to remove any particles.
3. Clean the tape drive wheel: the tape drive wheel is a small black rubber wheel located behind the head assembly. Use a swab moistened in head-cleaning solution and dab the tape drive wheel.
4. Push the tape retainer bar back in.
5. Clean the optic sensors: in the middle of the tape drive are two holes called optic sensors that are approximately an inch apart from each other. Spray these optic sensors with compressed air periodically to free them from built-up residue.
6. Clean the tape arm: in the middle of the tape drive and to the right side of the optic sensors, is a black arm that sticks out from the side. Clean this arm periodically with a swab.

### NOTE:

**On the clear side of the tape cartridge, there is a window in the middle that must be kept clean and uncovered or data cannot be read or written.**

## CIPHER 9-TRACK TAPE DRIVE

The Cipher tape drive installs in the expansion cabinet on slide-and-lock rails. This subsection describes the procedures to clean the following components:

- Top Plate Casing
- Filter
- Tachometer Roller
- Take-up Hub
- Roller Guides
- Reel Hub Pads
- Tape Head
- Tape Cleaner
- Optic Sensors

Use Freon TF, or IBM Tape Cleaner to clean the tape drive. Clean the Cipher tape drive, as follows (refer to Figure 8-1, *Cipher 9-Track Maintenance Locations*):

1. Unlock the tape drive from the cabinet: from the front of the cabinet, at the front-left of the drive is a recessed lock-handle that you unlock by gripping and squeezing the handle.
2. Withdraw the drive from the cabinet: using the recessed lock-handle, carefully pull the drive out of the cabinet until the slide rail-locks click into place or until the top cover of the drive clears the top of the cabinet.
3. Lift the top cover of the tape drive: grasp the front of the cover and lift up.
4. Lock the cover in place: to the inside left and rear of the cover is a plastic arm, swing the arm into its slot and release the cover.
5. Locate and clean the top plate casting: Use a lint-free cloth moistened with tape cleaner and clean the tape path area. Be careful not to get dirt on the other components.
6. Locate and remove the filter from inside the air duct opening at the lower left of the front panel (refer to Figure 8-1, *Cipher Air Filter Removal*). The filter installs in the same position as it was removed.
7. Clean the filter: using low pressure compressed air, blow air in the opposite direction of the fans airflow.
8. Install the clean filter: with the filter frame facing towards the front and the legs of the frame down, reinstall the filter inside the air duct opening.

9. Locate and clean the tachometer roller: use a cotton swab moistened with tape cleaner and clean the roller surface. Gently wipe the entire roller surface with the cotton swab and manually rotate the roller by turning the take-up hub slowly.

**CAUTION:**

**When cleaning the Tachometer Roller and Take-up Hub, place the Take-up Hub gently so it does not abruptly hit the Tachometer Roller, otherwise it might cause a flat spot on the Tachometer Roller.**

10. Locate and clean the take-up hub: use a cotton swab or lint-free cloth moistened with tape cleaner and wipe the tape wrapping surface while rotating the hub manually.
11. Locate and clean the roller guides: use a cotton swab moistened with tape cleaner and rotate each roller while gently wiping the tape contact surface and flanges or washers.

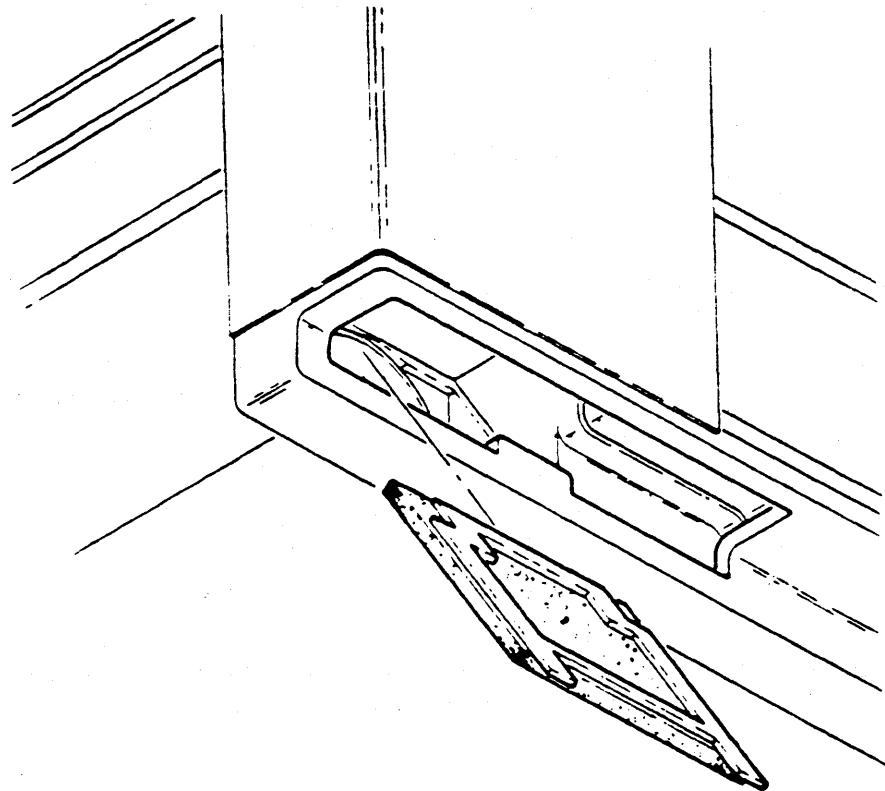

Figure 8-1. Cipher Air Filter Removal

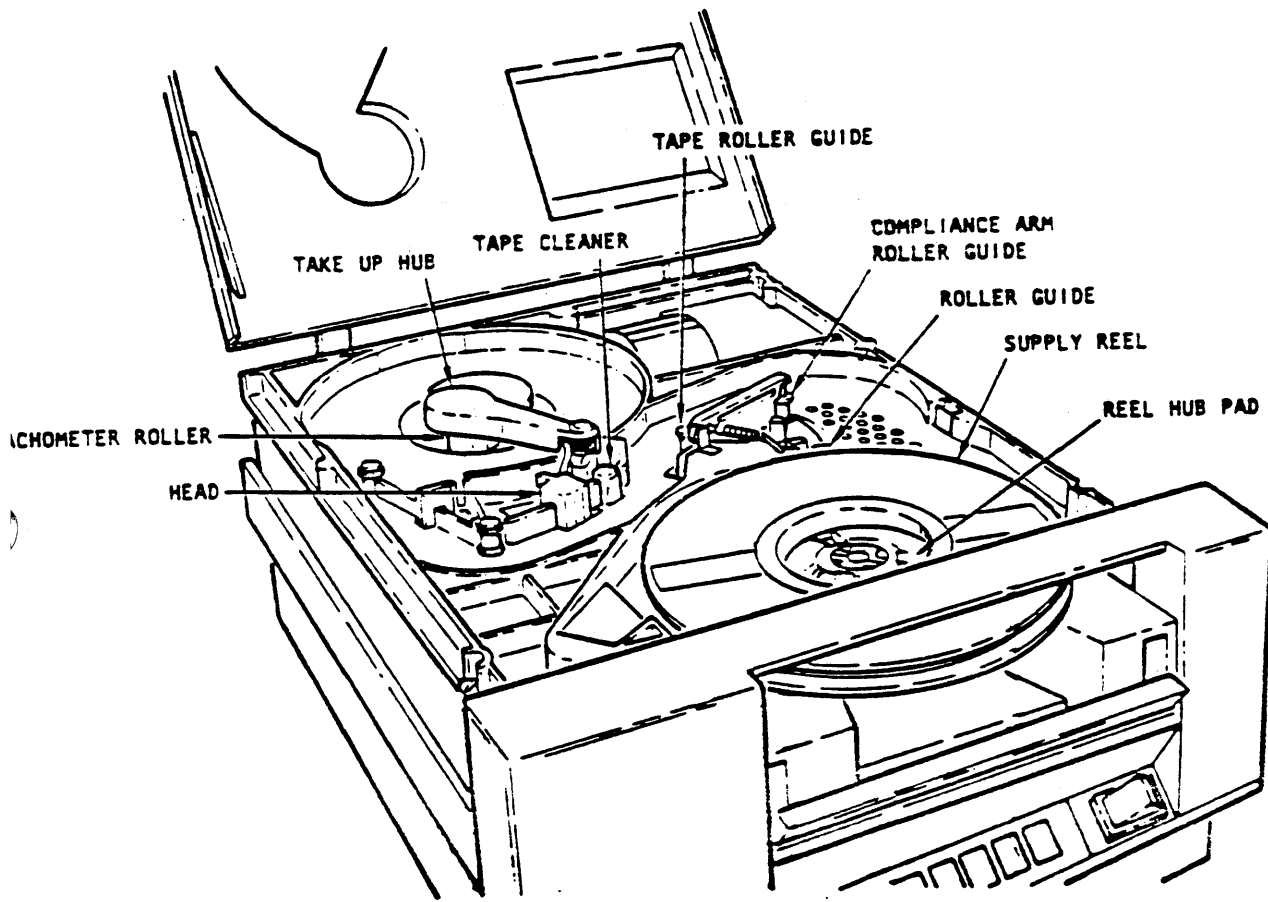

Figure 8-2. CIPHER 9-track Maintenance Locations

12. Locate and clean the reel hub pads: use a cotton swab or lint-free cloth moistened with tape cleaner and wipe the contact surface of each pad.
13. Locate and clean the tape head: use a cotton swab or lint-free cloth moistened with tape cleaner and wipe the entire face of the head and the attached erase bar, pay close attention to the recessed areas.
14. Locate and clean the tape cleaner: use a cotton swab moistened with tape cleaner and wipe each blade along the tape cleaners length to remove accumulated oxides from the recessed area between the blades.

**CAUTION:**

Use only a cotton swab moistened in Freon TF to clean the tape cleaner. A damaged tape cleaner will damage the tape.

15. Locate the optic sensors: in the middle of the drive are four optic sensors on the side of the tape path and two optic sensors located in the middle of the drive on the right side.
16. Clean the optic sensors: use a cotton swab moistened with tape cleaner and wipe the optic sensors.
17. Close the tape drive cover: lift the black cover of the drive up, push the plastic arm towards the rear and close the cover.
18. Push the tape drive back into the cabinet: On each side of the tape drive are the slide-lock rails. The locks are on both sides of the tape drive near the center of the rails. Push each rail lock in (on both sides) simultaneously and push the drive back inside the cabinet.



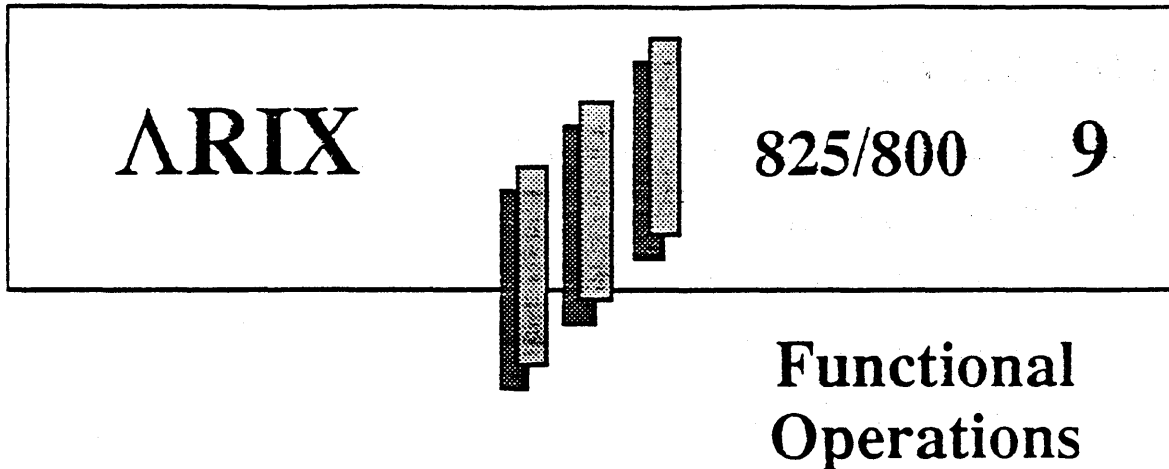

ARIX systems support high Input/Output (I/O) bandwidth required of on-line management information systems, while maintaining an extremely low cost per user. Traditional computer systems have large computational capabilities which frequently remain unused in the on-line environment. ARIX systems, through application-based optimization, have dispensed with much of this unnecessary hardware, resulting in a substantial savings to the ultimate end-user.

The ability of ARIX systems to provide cost-effective solutions to a broad spectrum of computing problems is directly related to its unique architecture. The multiple bus architecture from which the system derives its flexibility is a breakthrough in the design of systems in this class.

The logic boards that comprise the Computational Sub-system will be explained to show how their interaction with ARIX's Processor-Memory Bus (PMB) forms the powerful multi-thread nucleus of the system. The components of the I/O Sub-system including the Mass Storage Bus (MSB) are also described, as are the System Environment Controller and its related Utility Transfer Bus (UTB).

## ***BUS SYSTEM***

The architecture of the ARIX systems is built on four independent buses:

- the Communications and Control Bus (CCB)
- the Processor Memory Bus (PMB)
- the Mass Storage Bus (MSB)
- the Utility Transfer Bus (UTB)

These four buses all transfer information between the various boards across the system backplane. Each Sub-system has its own interconnect bus which has been optimized for superior performance in a specific area. The buses are "generic" and bus implementation is processor-technology independent.

### ***Communications and Control Bus (CCB)***

The CCB provides a means for the master Application Processor (AP) to acquire status from and send commands to all of the other processors in the system. Registers, on each board allow the master AP to determine the type of board in each slot of the backplane allowing complete automatic system configuration during power-up.

The CCB is a single master, multiple slave bus. The master AP is responsible for the timing of all transfers across the CCB. Each slave responds to a unique address which is derived from the slot location of that slave. Slaves may request the attention of the bus master by several priority interrupt request lines. Polling is used to determine which of several slaves requires service if more than one slave is assigned to the same interrupt request level.

The CCB provides the AP(s) the ability to address up to 64 Mbytes of memory. Each board in the system is allocated a total of 64 Kbytes of unique memory space out of the total 64 Mbyte address space available through the CCB. Locations at the top of each 64 Kbyte range are defined as control and status registers. These registers are present on all boards attached to the CCB and have certain information fields (such as board type) in prescribed locations. The address space below the required registers is used for application specific registers or memory.

### ***Processor Memory Bus (PMB)***

The PMB is the centerpiece of the Computational Sub-system. All data passing to and from the main memory is transmitted on the PMB. The PMB accommodates a 26-bit address field and a 32-bit data field which is protected against single bit errors by a seven bit error correction code (located on the DMC board). A logic board which desires communication with the main system memory asserts its own request line and awaits a grant response from the PMB bus arbiter located on the DMC board.

The type of memory operation performed by the system memory is determined by a PMB function code. For example, when the refresh interval timer on the DMC expires, a refresh cycle is requested. When the PMB arbiter grants a refresh cycle, a refresh code is placed on the PMB function code lines. This is a signal for all memory boards to perform a refresh operation on all RAM in main system memory. Other function codes are defined to indicate read, write, or read-modify-write memory cycles.

## ***Mass Storage Bus (MSB)***

The MSB services the I/O Sub-system and moves data blocks between the memory and the I/O Processors. The MSB provides a high speed parallel data "pipe" for the system. The data path of the MSB is 32-bits wide and has a bandwidth of 25 Mbytes per second. Within the design of the MSB are features which allow for flexibility and future enhancements.

The MSB is based on a multiple master, point-to-point transfer concept. In contrast to the PMB, an MSB bus master is chosen by periodic polling of a central arbiter RAM table. A new master can be selected every MSB clock period, or a single master may be given the bus for several cycles. Access to the MSB is granted to any of up to 15 devices on a periodic basis through the use of a polling table which drives the bus arbiter. A "pointer scheme" allows fast switching of the number of bus access opportunities a given device will have per unit time. The MSB dynamically adapts to changing system loads in real time; that is, the MSB dynamically allocates I/O bus bandwidth according to the needs of a specific process.

The I/O device whose board ID code corresponds to the polling table value being presented on the bus, becomes the master of the MSB for that cycle. If the newly selected bus master requires use of the MSB, the master enables the function code and the ID code of the new master onto the MSB. The function code emitted by the MSB master defines the direction of data flow on the MSB. For example, a "Read Data" code means that data is sent from a slave to the master.

All MSB transactions occur in a single cycle of the MSB bus clock. If a transaction is not ready to proceed at the time a bus master is chosen by the bus arbiter, a NO Operation (NOP) function code is executed for the particular cycle in question. All transactions are point-to-point operations.

MSB slave logic on each I/O device monitors the slave board ID and function code signals. When a slave ID match occurs the slave executes the function code request. When the slave has executed the function code request, a Slave Acknowledge signal is generated which notifies the bus master that the current MSB transaction complete.

## ***Utility Transfer Bus (UTB)***

The UTB passes system status information to the master AP. Temperature sensors are located at strategic points in the system near the disk and tape drives, the power supply, and inside the card cage.

If the temperature of any of these areas exceeds a preset limit, the sensors assert a status code on the UTB. The main AP board of the system reads the status code and initiates an action based on the status received from the sensor(s). If necessary, the master AP (through the UTB) shuts down the system to prevent damage to the system components.

The UTB allows the master AP dynamic control, within preset limits, of the output of the +5 volt system power supply. Performing diagnostic tests of preset limits of the power supply allows early detection of certain system failures, and permits corrective action to be taken before catastrophic failure occurs.

## ***Backplane***

The backplane provides the physical environment for the four buses. The system boards physically connect to the backplane through DIN connectors in each slot position. The slot positions are 0.80 inches apart providing better cooling and improving overall system reliability. The buses on the backplane pass electrical signals to and from the logic boards in the system.

Since the backplane is involved in transmitting high speed signals, its electrical properties are extremely important. Building the backplane of seven layers, two power, two ground, and three signal layers, provides the optimum power and ground distribution resulting in the best possible signal conditions.

The basic differences between the ARIX Models 825/800, 850/1200, and /1600 systems are the number of bus slots in the backplanes, and the type and number of peripherals available. The Model 825/800 has a 10 slot backplane while the 850/1200 and 875/1600 have 19 slot backplanes. The same type of logic boards, software, and diagnostics exist on all models.

ARIX provides the following three board categories:

- Application Processor and Memory boards
- I/O Processor boards (DP, ICP, and MAC)
- DMC board (DMC4 or DMC4/2)

These three categories of boards insert into specific slots of the backplane.

The slot divisions of the backplane are based upon the communications requirements of the three different categories of boards. AP and Memory boards communicate over the PMB and the UTB. The master AP monitors system status on the UTB. The I/O Processor boards (DP, ICP, VAC and MAC) communicate over both the MSB and the CCB. The DMC board transfers information between the PMB and MSB. All three categories of boards communicate over the CCB. The physical division of the bus corresponds to the logical division of the architecture.

## COMPUTATIONAL SUBSYSTEM

The computational subsystem consists of the following three types of logic boards:

- Application Processor board
- DMC board
- Memory board

These boards communicate to the system through the bus Sub-system provided by the backplane.

### *Application Processor*

The Application Processors (APs) use the Motorola 68020 microprocessor running at clock speeds of 12.5 MHz (CPU32), and 25 MHz (CPU32/25). The 68020 is a fully integrated 32-bit microprocessor with a full 32-bit architecture. The 68020 processor provides several features, including a large unsegmented address space, 17 general purpose registers, and a high-level language instruction set.

Maximum performance of the 68020 is accomplished by an 8 Kbyte (on CPU32) or 64 Kbyte (on CPU32/25 MHz) high speed cache memory. The cache memory, is a "write-through" cache and provides the CPU32 and the CPU32/25 with no-wait states.

ARIX employs a proprietary Memory Management Unit (MMU) that supports the requirements of the operating system stressing high performance. The MMU allows scatter loading of processes, relocation at the physical level, and multiple page protection modes.

An on-board clock/calendar circuit provides real-time clock and calendar functions. The clock has an accuracy of 10 parts-per-million (PPM) at a frequency of 32.768 KHz. Two programmable on-board RS-232C serial communications channels provide the system console, and the remote diagnostics ports. Firmware on the board includes power-on self-test, monitor, system diagnostics, and the initial program load sequence.

The AP communicates with the other electronic components of the system through the CCB, the PMB, and the UTB. A distinct architectural feature of ARIX systems is their ability to support multiple, tightly coupled APs. As a function of the tightly coupled architecture, these APs all execute from a common main memory. Distributed processing solves many operating system problems normally associated with distributed intelligence.

### *Multiple AP Capabilities*

A tightly coupled multiple AP architecture allows the ARIX system to provide a substantially larger computational capacity to the user without the corresponding increase in cost of a typical single CPU system.

The ARIX architecture supports one master and several slave APs. The hardware and firmware are identical on all APs. The AP board is configured to either master or slave form with a toggle switch option. The current configuration is indicated by a master/slave status indicator and the position of the toggle switch on each board.

The master AP and the slave AP(s) each have unique board ID codes that allow the master AP to automatically configure the system. By reading the board ID code over the CCB, the master AP determines the number and locations of each slave AP in the system.

The master AP is responsible for scheduling all system resources, memory management, and all operating system functions. The master AP controls and directs the I/O for the entire system. The slave APs are strictly used as a computational resource for user programs.

## *Memory Management Unit (MMU)*

The MMU employs a two level address translation technique allowing the AP to map all processes at logical address zero and scatter load processes into any set of 4 Kbyte physical pages. The MMU provides multiple protection modes to protect any physical page from an illegal access. To allow the implementation of efficient demand-paged virtual memory algorithms, the MMU keeps access statistics on each physical page.

In the case of any access fault, the type of fault is latched into a special fault register, which is read by a fault recovery routine that determines and responds to the fault. This feature provides protects each page from unauthorized access (providing a degree of data security), and produces a fault when a page access is attempted and the desired page is not in memory. This function provides a demand-paging virtual memory environment.

## *Cache Memory*

With multiple APs accessing a common main memory, there is contention for this shared resource of main memory. In order to support the demands of multiple APs on main memory, and to minimize PMB contention, each AP has its own private 8 Kbyte (CPU32) or 64 Kbyte (CPU32/25) cache memory.

The high-speed cache memory allows each AP to run near full speed, since any cache memory cycle incurs no wait states. Most memory accesses are from the cache which lessens the traffic on the PMB.

The cache includes a PMB monitor that assures cache concurrence at all times. The PMB monitor allows writes to main memory from any source, including DMA, without danger of invalid data occurring in any individual cache and without flushing the cache data.

Cache hit rates on the system have been measured between 93 and 96 percent on a typical instruction mix. This allows a greater number of APs on the PMB and minimizes the impact on DMC activity.

A read from main memory is cached. A "write-through" cache instruction writes through the cache and if that location is already cached and being written to main memory, both are protected.

The main memory and the cache are both 32-bits wide, with memory reads fetching a 32-bit word from either the cache or the main memory.

## **CACHE THEORY**

The cache memory is part of the overall concept of storage hierarchies where smaller, faster (more expensive) memories are placed closer to the processor, while larger, slower (less expensive) memories are used to fill the cache. This concept works due to "locality of reference" which may be observed in most programs. Most references within a program, over a short period of time, come from "working sets" of storage locations. The faster cache memory tracks these storage locations, while main memory holds the rest of the program until needed. Using this concept, the overall speed processing system approaches that of the fastest level.

At any one time, the cache contains copies of memory words containing bits and pieces of instructions and data. When the processor makes a memory request, the processor generates the address of the datum and searches the cache for the data. If the data is available, a "cache hit" occurs, and a copy of the data is passed back to the requesting processor without accessing main memory (ensuring zero wait states).

If the data is not in the cache, then a "cache miss" occurs. The address requested is passed to main memory. When the data is provided by main memory, the cache stores a copy of the data and the AP receives the data.

## **CACHE DATA BITS**

The cache memory in a CPU/32 is 8 Kbytes in size and is configured logically as two sets of memory that are 4K by 32-bits each. When the 68020 microprocessor accesses the cache, a full 32-bit cache word is provided. The cache and main memory is 32-bits in width.

The cache is a "direct-mapped cache," meaning that each memory location is only loaded into one location in cache. The location in cache which receives a given piece of data is determined by that data's physical memory address modular 4 Kbytes. There is one location within each 4 Kbyte page of main memory which, if requested by the processor, is loaded into the same location in the cache.

For example, the data at physical address 000800 Hex in main memory would arrive at the same location in cache as the data at physical address 001800 Hex.

## **CACHE TAG BITS**

In addition to the data area of the cache, TAG bits are associated with each cache location, and determine whether a given physical memory location is cached or not. To meet the speed requirements of the 68020 at 12.5 MHz or 25 MHz, and to allow the continuous monitoring of the PMB by the cache for updates, two identical sets of TAG bits are maintained on each AP board. One TAG set checks for "hit or miss" on request by the AP for a location from memory, while the other TAG set monitors the PMB for possible cache updates.

## ***Processor I/O***

Most communications are through the PMB or the CCB; all other I/O types are through the master AP, as follows:

- The system console port
- The remote diagnostic port
- The system status port
- The AP status display LEDs

### ***SYSTEM CONSOLE PORT***

Console operations consist of two serial communications ports on the master AP board. The console port defaults are, as follows:

- 9600 baud; can toggle to 2400, 1200 and 300 baud.
- No parity
- 8-bit ASCII
- X-on/X-off protocol

The remote diagnostic port defaults are, as follows:

- 1200 baud; can toggle to other baud rates when remote diagnostic mode is used.
- No parity
- 8-bit ASCII
- X-ON/X-OFF protocol

When using either port, remember that the console port is a DCE interface, and the diagnostic port is a DTE interface (refer to section 5, *Terminals, Printers, and Modems*).

### ***SYSTEM STATUS INPUT REGISTER***

This register stores the environmental and power status of the system. The master AP reads this register allowing the operating system to preserve the integrity of data stored in main memory and on the disk subsystem in case of a possible power failure or over-heating condition. The error codes are shown in Table 9-1, *System Status Error Codes*.



Table 9-1. System Status Error Codes.

Error Code	Indication
ACFAILURE	AC line failure.
DISK1HOT	Over-heating condition of disk 1 in the main cabinet.
DISK2HOT	Over-heating condition of disk 2 in the main cabinet.
DISK3HOT	Over-heating condition of disk 3 in the main cabinet.
DISK4HOT	Over-heating condition of disk 4 in the main cabinet.
PSHOT	Over-heating condition of the power supply.
CARDCAGEHOT	Over-heating condition of the main cabinet.

### **DIAGNOSTIC LED DISPLAY**

On the front of the AP board are eleven LED displays that show the status of the AP board(s). The top three LEDs on each board are the diagnostic LEDs, the rest are the board activity LEDs.

The diagnostic LEDs show the status of the board(s). The red LED (FLT) indicates the board has failed the self-test diagnostics, the yellow LED (TEST) indicates the AP is in a power-up or self-test condition, and the green LED (NORM) indicates the AP passed its diagnostics and is operational.

The remaining LEDs are general purpose diagnostic displays that display board or diagnostic status codes.

### **PROM MONITOR**

In the event of a diagnostic test failure, the PROM provides a monitor which allows on-line debugging of the hardware.

### **DIRECT MEMORY CONTROLLER (DMC)**

The main function of the DMC is to control the memory subsystem, including refresh of dynamic RAM, error detection, error correction, and limited error logging. The memory Sub-system is composed of the DMC and one or more memory boards. Only one DMC is used in each system.

The DMC also manages several timing and control functions of two of the backplane buses. The DMC arbitrates access to the MSB by the various I/O Processors, provides dynamic allocation of MSB bandwidth, and controls the memory access requests from the DMA channels and the APs sharing the PMB. All bus access arbitration is provided by the DMC, and the clocks used by these buses are supplied by the DMC.

### ***CCB INTERFACE***

The AP and DMC boards use the CCB to pass instructions, perform diagnostic operations, and to control the configuration registers of the DMC. The DMC establishes DMA channels over the CCB, or by the normal mode of operation over the MSB. The DMC can interrupt the master AP over the CCB.

### ***PMB INTERFACE***

The PMB is a 32-bit wide high speed bus and is shared by all APs and memory boards of the system. The PMB passes all instructions and data between the APs, memory boards, and DMA channels.

An arbiter on the DMC controls which board may use the PMB at any given moment. This prevents the contention that occurs if all devices on the PMB try to use the bus simultaneously.

All devices attempting to use the PMB must make a request to the DMC and the requesting device with the higher priority acquires the PMB. Arbitration logic on the DMC allows up to seven requests. The priority of the requests are fixed.

Priority requests are ordered as follows: memory refresh cycles have the highest priority, next are the channels of the MSB DMA, and the third are reserved for the APs.

The MSB interface provides the path by which the APs read or write data into and out of main memory. The MSB interface is coupled tightly to the MSB DMA and achieves a transfer rate of 25 Mbytes per second through the 32-bit wide bus between memory. The MSB allows access of up to 10.5 Gbytes of magnetic disk mass storage with excellent response times.

Like the PMB, the MSB uses an arbiter assuring that only one bus master is enabled at any given time. On the MSB, the arbiter is software-configured to allow variable allocation of bus usage between high- and low-speed devices. When the current CCB master accesses the MSB arbiter register, the MSB arbiter is disabled.

A two-bit arbiter index register is provided for rapid context switching between four internal arbiter tables. These tables are pre-programmed by the operating system for optimum MSB bandwidth operation and follow specific operational modes.

By issuing a single instruction, with four arbiter tables available, the operating system alters the portion of the MSB bandwidth a device will receive.

### ***DIRECT MEMORY ACCESS CONTROL***

Two DMC boards, the DMC4/2 supports two channels and the DMC4 supports four high speed DMA channels, are available. Each of the channels address the full range of main memory.

Each DMA channel is 26-bits wide with a 16-bit wide length count, allowing up to 256 Kbytes of data to be moved in a single DMA transfer operation. The DMA channels are able to transfer 32 bits of data at a time. DMA channels link main memory to the MSB.

Only one channel transfers data between the PMB and the MSB. The DMA channels can simultaneously transfer data between the MSB and memory. The transfer cycles to and from the MSB are arbitrated on a rotating priority by the DMC interleaved with AP cycles over the PMB.

### ***MEMORY REFRESH CONTROL***

The DMC controls and initiates memory refresh for all memory boards. The DMC refreshes 128 rows of the dynamic random access memory (DRAM) every two milliseconds by generating a RAS address, a refresh function code, and a 'GO' signal. The memory refresh cycle is scheduled, along with all other memory access requests in a priority access scheme.

### ***ERROR DETECTION AND CORRECTION (EDAC)***

The DMC supports memory check-bit generation, error detection, and single-bit correction in discrete logic for high speed operation with a hamming code.

Each time data is written to main memory, a seven-bit EDAC check-bit pattern is generated based on the pattern of the data being stored. The seven-bit EDAC check-bit pattern is stored in memory along with the 32 bits of data, resulting in 39 bits of memory.

During each read operation, the DMC EDAC logic generates a syndrome using the data and check bit pattern generated during the write operation. The syndrome pattern provides verification of the data, and the reconstruction of the data in the event of a single bit error. If a single bit error occurs, the data is corrected and delivered to the reading device. The address of the failure is stored on the DMC board to allow failure analysis by the system software.

Multi-bit errors are detected but the syndrome pattern does not contain enough information to correct the error. The DMC board interrupts the master AP if a multi-bit memory error occurs and the interrupt level associated with memory errors is enabled. A message is displayed on the console and the master CPU initiates shutdown procedures.

The memory error status bits readable by the CCB are, as follows:

- the 24-bit physical address of fault
- the 7 check bits
- the 4 byte selects
- the R/W status
- a 3-bit code identifying the bus master
- the syndrome bits
- whether the error was correctable

Registers are provided on the DMC to allow diagnostics to modify the logic. This capability can be used during system background diagnostics and by standard field diagnostics.

## *Memory Board*

The memory board use Dynamic Read-And-write Memory (DRAM). Memory boards provide the system with either 2 (for older systems only), 4, 8, 16 or 32 Mbytes of main memory that is accessible by the APs and by I/O Processors through the DMC. All data transfers and communication with memory is accomplished over the CCB and MSB.

### *MEMORY ORGANIZATION AND PERFORMANCE*

Memory boards that use the high density 256 Kbytes DRAM ICs support up to 2 (for older systems only) 4 or 8 Mbyte boards, not to exceed 16 Mbytes of main memory. Memory boards using 1 Mbyte dynamic RAM ICs support 8, 16, or 32 Mbytes of main memory per board, not to exceed 64 Mbytes. A system containing a memory board populated with 1 Mbytes ICs must also contain the 25 MHz AP (CPU32/25) board.

The memory array consists of 8 banks of 39 bits. Each memory location is composed of 32 data-bits and 7 check-bits. The check-bits are EDAC-bits generated by the DMC board. All EDAC logic is contained on the DMC board. A full description of EDAC operation is given in the DMC section.

The memory board has an access time of 400 nanoseconds for read operations, an access time of 320 nanoseconds for write operations and an access time of 600 nanoseconds for read-modify-write operations. If no read errors are detected, full speed operation of the AP cache and system DMA is assured.

### **CCB INTERFACE**

A minimal CCB interface is provided on the memory board. It allows the system to select the address range for the board, read the board type and size, and to write to the LED display on the board.

No user selection of memory board addressing is required on the system. Upon initialization, the operating system reads the board type and determines the on-board memory size by reading the data on the CCB. Each slot in the backplane generates a unique CCB interface address for the board installed.

The operating system polls the slots to identify each board through CCB slot addressing. Once the board is identified, its configuration is read to determine the actual amount of memory on the board. The operating system configures each memory board in the system with its address range.

Seven LEDs are provided on the memory board to aid analysis of the operation of the memory Sub-system. During normal operation, the LED display indicates resource allocation and activity. Under control of diagnostics, the LEDs are used as error code displays to aid in the localization of system faults.

### **PMB INTERFACE**

The memory board supports four types of PMB transactions in conjunction with the DMC. These PMB transactions are four types of memory cycles, as follows:

- Read
- Write
- Read-Modify-Write (RMW)
- Refresh

The Read, Write, and Read-Modify-Write cycles all operate on full 39-bit quantities. The Refresh cycle causes all of system memory to be refreshed.

## ***INPUT/OUTPUT SUBSYSTEM***

The I/O subsystem consists of the following:

- the Intelligent Communications Processor (ICP)
- the Database Processor (DP)
- the Multibus Adapter (MBA) board

### ***Database Processor (DP)***

The DP is an intelligent Motorola 68000-based I/O controller, capable of reading or writing both disk and tape devices without intervention from the AP. Three versions of the DP support SMD, ESMD, and SCSI disk drives and either a streaming cartridge or 9-track tape drive.

Various mass storage related functions normally implemented in the operating system are accomplished by software that is down-loaded to the DP. For example, the AP requests logical sectors from the disk drive rather than physical ones. This frees the AP from the time consuming task of checking spare tables and calculating the physical position of a logical sector.

### ***COMMUNICATIONS AND CONTROL BUS INTERFACE***

The CCB interface allows slow speed interrupt-driven communication between the master AP and the DP(s). The CCB provides a control interface between the master AP and the DP. Due to the "block-data" nature of the DP, a number of block transfer requests can be queued in the DP's dual port memory.

An RS-232C interface supports asynchronous serial communications and provides a port for monitoring diagnostics.

When the DP initializes, it executes code from a PROM. This PROM contains all the diagnostics and the power-up initial program load. When the processor passes the diagnostic tests and loads its boot program from the disk or tape, it starts running code from RAM and maps the PROM out of its address space.

The RAM is implemented with high speed static RAM memory ICs. The DP uses this memory to buffer data and programs.

### ***DATA BUS CONTROL (DBC)***

The DBC provides a common interface for disk, tape, and DP processor to the local data buffer and the MSB. The DBC is a demand priority-arbitrated, time-multiplexed bus; the DBC is a bidirectional, 32-bit wide bus that supports byte as well as full word transfers. The requesting device (DP processor, the MSB control logic, and the DP internal DMA) addresses local memory.

Disk and tape data control is provided by a state machine contained in the disk and tape control block. This high speed state machine controls and arbitrates the access to the dual port memory of the DP.

The DP processor controls the flow of data between disk, tape, local data buffers, and the MSB through a set of read/write control registers.

### **MASS STORAGE BUS INTERFACE**

Control for the MSB interface is provided by the disk and tape control block. The 68000 provides the intelligence to allow multiple chained transfers over the MSB. All of the data moved to and from main memory to either the disk or the tape is moved over the MSB.

The MSB interface provides a high speed 32-bit data channel between the disk, tape, local DP resources and main memory. The MSB interface performs direct transfers to the disk and to the local data buffer under control of disk and tape data control. The DMC is programmed by storing the DMA address and byte count in the local data buffer with the parameters then transferred through the MSB.

Automatic chaining of MSB data transfers may also be performed by setting up a list of system DMA parameters in the local data buffer, and specifying chained operation. The transfers between the MSB and the tape or the DP local processor are performed by transferring the data to the local data buffer followed to the MSB. The DP local processor 68000 controls the MSB interface operation through a set of read/write control registers.

### **INTERFACE BUS (IB)**

The DP communicates with its interface board through a physical direct connection, the IB. All of the integrated circuits which drive and receive signals from the disk and tape drives are mounted on the interface board.

### **DISK AND TAPE DRIVE**

On-line management information systems are frequently limited by the speed and reliability of their mass storage devices. ARIX provides a solution to this problem by using the fastest and highest quality mass storage devices available. Mass storage is provided by Winchester technology disk drives (168, 337 or 824 Mbyte SMD and HSMD, 170 and 380 Mbyte SCSI disk drives).

In addition, a quarter-inch streaming cartridge tape drive (45, 60, and 150 Mbytes) or a 9-track half-inch tape drive (92 and 180 Mbytes) can be utilized. Adding storage capacity is simplified by using the industry standard SMD or ESMD disk interfaces, Pertec 9-track tape interface, and QIC-02 1/4" cartridge interface.

## ***Intelligent Communications Processor (ICP)***

The ICP is an intelligent controller for serial and parallel communications. The ICP allows the system to control up to sixteen serial lines. The ICP uses a 10 MHz 68000 microprocessor which manages the direct control of ports. This frees the master AP from the time-consuming task of processing character-by-character interrupts from synchronous and parallel devices.

In addition, the ICP is capable of various transformations and formatting of data being sent to and from the serial ports. The interface between the master AP and the ICP is the CCB. The implementation of the CCB on the ICP provides 64 Kbytes of dual-ported memory space. The master AP views this 64 Kbytes as a part of its memory space.

### ***CCB INTERFACE***

The CCB is the ICP's only interface to the system. All data transfers to and from the master AP and the ICP are made on the CCB. The interface consists of two separate parts, the dual-ported memory and the interrupt status registers.

The 64 Kbytes of dual-ported memory occupy a portion of the address space of the 68000 microprocessor on the ICP. When the master AP wants to transfer blocks of data to the ICP, it uses software protocols in the dual ported RAM.

Since both the master AP and the 68000 on the ICP can write into all of the 64 Kbytes of dual port memory at any time, it is mandatory that these protocols be observed when using this aspect of the CCB.

A Test and Set (TAS) feature is implemented in the hardware of the CCB status register to aid in protocol implementation. The TAS operation allows the atomic, indivisible transfer of control between two processors.

The master AP or the ICP can read the TAS bit. If the bit was zero, it is set and the processor which read the zero can access any shared data structure without conflict. After the data structure is updated, the processor doing the update is obligated to reset the TAS bit.

The interrupt register part of the CCB interface consists of two sets of unidirectional registers. A pair of registers is used to send data from the master AP to the ICP, and the alternate pair are used to send data from the ICP to the master AP.

When the master AP writes into the register which can be read by the ICP, the bits in this register pair generate interrupts to the 68000 on the ICP. An interrupt is given to the master AP when the registers going from the ICP to the master AP are written into. This process serves as a completely asynchronous communications channel between the two processors. It is this aspect of the interface which is used to synchronize the communications through the dual ported RAM.



## **PROCESSOR AND MEMORY SECTION**

The processor used on the ICP is a 10 MHz 68000, and supports up to 64 Kbytes of EPROM which is used to run diagnostics and initialize the ICP. Each ICP supports 512 or 1024 Kbytes of RAM, using 256K dynamic RAM ICs. The 68000 is able to address all 64 Kbytes of the dual-ported RAM as normal 68000 memory, and can operate without wait-states in this memory.

## **I/O SECTION**

The I/O section of the ICP is built of three basic parts: the serial control and I/O circuitry, the register section of the CCB, and the ASCC/SCC memory section. The serial section consists of Zilog ASCCs, SCCs, and RS-232C line drivers. All of these sections are addressed through the 68000's memory space.

## **SOFTWARE DESCRIPTION**

There are two kinds of software: the PROM resident monitor including boot-strapping routines; and the down-loaded nucleus and applications software. Note that applications software in this case is NOT a user application. Rather, it consists of port drivers which live on top of the real-time nucleus within the ICP.

## **HARDWARE RELIABILITY**

Diagnostic loopback controls, dedicated diagnostic EPROMs on each board, and modular hardware are included in the system to aid in localizing and correcting faults.

ARIX design goals are for fast, reliable, expandable and maintainable systems.

Each major board such as the AP, ICP and DP use intelligent on-board processors with board-specific self-test processes. Status LEDs show the board progress at all times. These features allow extensive fault localization.

## **Temperature Monitors**

There are two temperature sensors in the Model 800/825 that warn the master AP of a temperature problem. The sensors are connected to all of the disk drives, the card cage and the power supply.



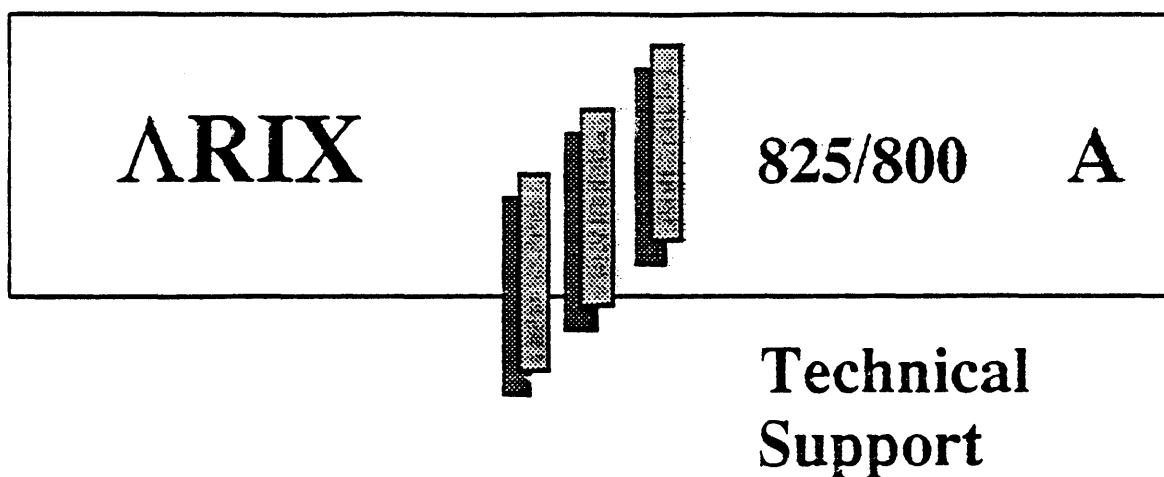

Warranty and Support Agreement assistance for this debugger software is available from ARIX Customer Support. Contact us by telephone at:

- **800-237-2783** from outside California
- **800-521-5783** from inside California and outside the 408 area code
- **408-432-1200** and ask for Customer Support

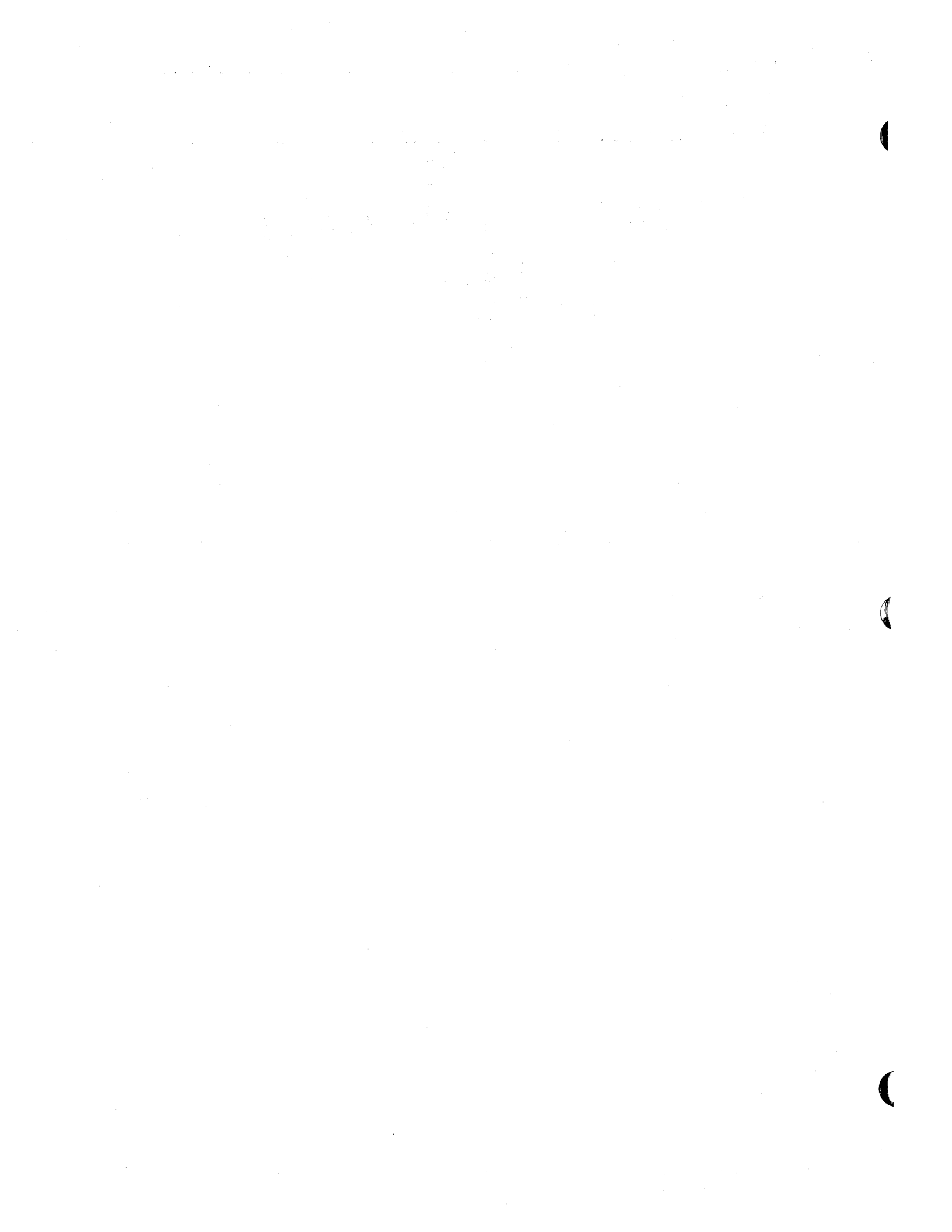

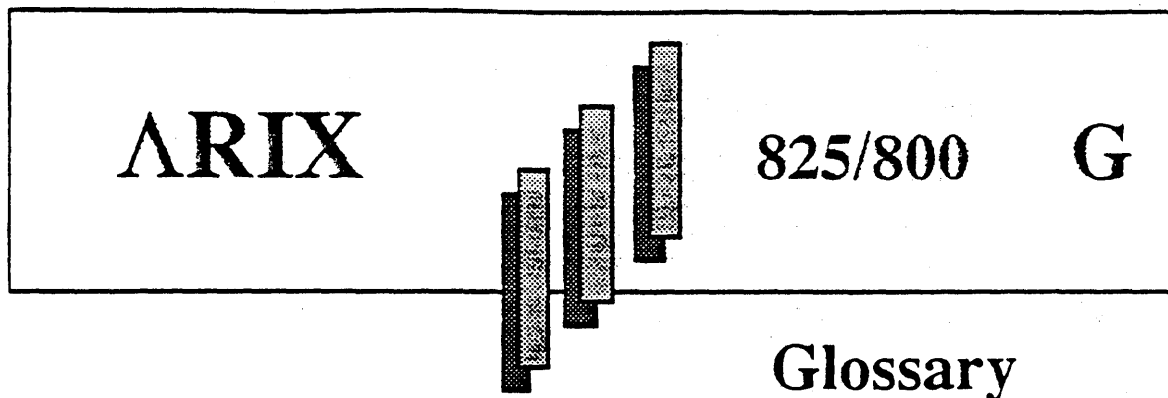

The following list describes the frequently used terms and acronyms in this manual.

- AP** Applications Processor: defines the CPU board running one or more applications simultaneously (see CPU).
- ARIX** *Arête Release of the UNIX operating system.* The company that manufactures several 68020-based multi-application processing systems
- Archive** The manufacturer of a mass storage device, a quarter-inch cartridge tape drive, that is used in ARIX systems.
- Board** The printed circuit board that contains the electrical paths to the ICs; Board is the shortened term of PCB (see PCB, Card).
- BMC** Bus Memory Control (see DMC, DMC2, DMC4/2).
- Card** The printed circuit board that contains the electrical paths to the ICs; Card refers to a board that installs into the card cage (see PCB, Board)
- CCB** Communication and Control Bus: also known as the Interprocessor Communications Bus (see ICB).
- CPU** Central Processing Unit: the brain of the ARIX system: when running several software packages, an Applications Processor (see AP).
- CPU16** ARIX CPU board using the Motorola 68000 16-bit CPU as the main controller, and a clock speed of 12.5 MHz.
- CPU32** ARIX CPU board using the Motorola 68020 32-bit CPU running at a clock speed of 12.5 MHz.
- CPU32/25** ARIX CPU board using the Motorola 68020 32-bit CPU running at a clock speed of 25 MHz.
- DCE** Data Communications Equipment: modems or systems to communicate with other modems or systems (see DTE; Section 5, Terminals, Printers, and Modems).
- DCP** Data Communications Processor: the GC/EGC/GC16 data communication logic board (See ICP, GC, EGC, and GC16).
- DMA** Direct Memory Access: performing read and write memory operations without, or with minimal CPU interaction.

DMC	Direct Memory access Controller: a controller that reads and writes to main memory without direct CPU control. The ARIX DMC is a two- or four-channel DMA controller, where each channel supports an EDT or HSDT board (see DMC4, DMC4/2).
DMC2	Direct Memory Controller-2 supports two DMA channels. The DMC4/2 replaces the DMC2 (see DMC, DMC4/2).
DMC4	Direct Memory access Controller-4 supports four DMA channels (see DMC).
DMC4/2	Direct Memory Controller-4/2 supports two DMA channels. The DMC4/2 replaces the DMC2 (see DMC, DMC2).
DRAM	Dynamic Read And write Memory: used as temporary data storage. Volatile memory (see RAM, SRAM).
DTE	Data Terminal Equipment: terminals and printers are DTE devices that require a protocol arrangement to communicate with modems/systems (see DCE: Section 5, <i>Terminals, Printers, and Modems</i> ).
EDAC	Error Detection and Correction.
EDT	Enhanced Disk/Tape controller.
EGC	Enhanced General Purpose Communications controller.
EPROM	Erasable Programmable Read Only Memory: used to store micro-code for boot and diagnostics. Non-volatile memory.
ESMD	Enhanced Storage Module Device, a performance enhanced version of SMD capable of 2.4 Mbytes per Second transfer rates.
FRU	Field Replaceable Unit.
Gbyte	Gigabyte, one billion bytes ( $1 \times 10^9$ bytes).
GC	General Communications controller.
GC/IF	General Communications interface board, an interface providing eight serial ports and one parallel port.
HSDT	High Speed Disk Tape controller.
ICB	Interprocessor Communications Bus.
ICP	Intelligent Communications Processor: refers to the logic and interface boards of the GC, EGC, and GC16 (see DCP).
IDP	Intelligent Database Processor: the disk tape controller logic board (See EDT, HSDT, and SCSI).
IEC	International Electro-technical Commission (an international safety agency).
I/O	Input/Output.
IOCP	Input/Output Control Processor.
MAC	Multibus Adaptor Card, an A1000 I/O card that adapts the ICB to the IEEE-796 bus.

MCP	Modular Communications Processor: an intelligent multiplexer that expands the serial port capacity of a ICP (DCP) module. Using one synchronous I/O port of the ICP, the MCP provides sixteen 9600 baud asynchronous ports.
Mbyte	Megabyte, one million bytes ( $1 \times 10^6$ bytes).
MHz	MegaHertz (million cycles per second).
MMU	Memory Management Unit.
MSB	Mass Storage Bus: also known as the Data Transfer Bus (DTB).
Multibus	An industry standard 16-bit microcomputer bus (also referred to as IEEE-796).
PC	Printed Circuit boards: definition of a board designed with electrical paths to various components and integrated circuits (ICs) (see Board).
PMB	Processor Memory Bus: 32-bit bus passes all instructions and data between the APs, memory boards, and the DMA channels.
PROM	Programmable Read Only Memory: used to store micro-code for boot and diagnostics. Non-volatile memory.
RAM	Random Access Memory: temporary data storage; volatile memory. (see DRAM, SRAM).
SCSI	Small Computer Systems Interface: a data transfer protocol used in bus configurations.
SMD	Storage Module Device: a data transfer speed to/from disk drives, limited in the ARIX systems to 168MB disk drives, and 1200 and 1600 systems (see ESMD).
SRAM	Static Read And write Memory: used to store data, non-volatile (see DRAM, RAM).
nS	nanosecond (one billionth of a second; $1 \times 10^{-9}$ ).
Pertec	An industry standard interface to half-inch nine-track tape devices.
QIC	An industry standard interface to quarter inch tape devices.
SMD	Storage Module Device, an industry standard interface to fixed-disk magnetic storage devices.
TUV	German safety and emissions testing organization.
UL	Underwriters Labs (safety agency).
UPS	Uninterruptible Power Supply: used to backup power service; supplies 5 to 10 minutes of power to the system to allow administrators to save data, and shutdown the system. (The UPS is no longer supported by ARIX.)
UTB	Utility Transfer Bus: system environmental control.
uS	microsecond (one millionth of a second; $1 \times 10^{-6}$ ).
VAC	VMEbus Adapter Card: provides translation between the A1000 bus and the VMEbus through an adapter card interface.
VDE	German safety and emissions standards organization.

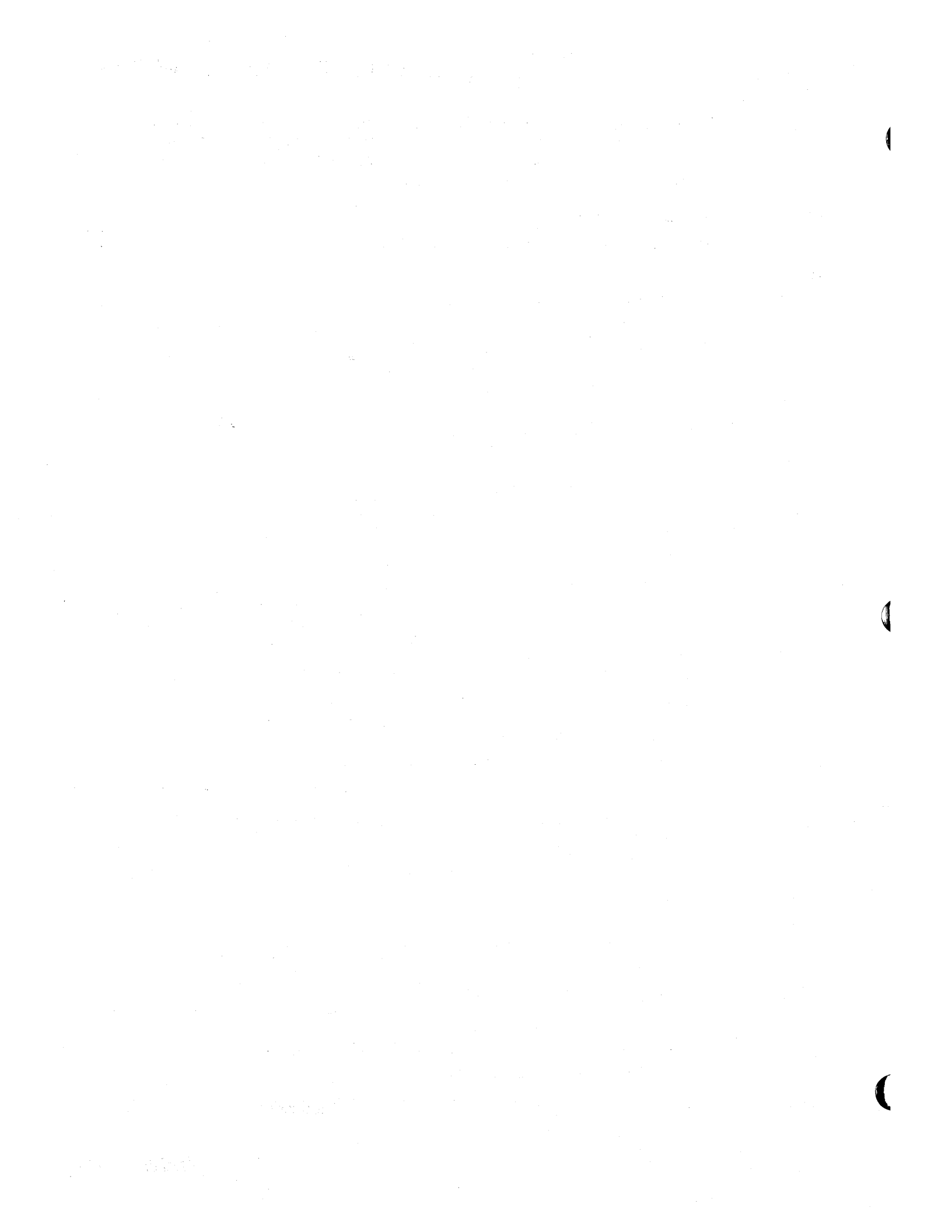



**ARIX**  
Corporation

*Uninterruptible Power Supply  
Application Guidelines for  
the ARIX A1000  
Series*

ARIX Corporation

821 Fox Lane

San Jose, CA 95131

Part No. MA-99378-00 Rev. A

The document contains proprietary information issued with the corresponding system product under the terms of a written agreement.

Copyright 1989, ARIX Corporation. All rights reserved.

No part of this publication may be reproduced without the express written permission of ARIX Corporation. The information in the publication is subject to change without notice, and is considered to be current at the time of preparation. This information is provided as a convenience to the user, and by acceptance thereof, the user specifically releases ARIX Corporation from any liability for material or consequential damages.

# ***Table of Contents***

<b>Chapter 1</b>	<b>Introduction</b>	
	UPS - General Information.....	1-1
<b>Chapter 2</b>	<b>UPS Environmental and Electrical Guidelines</b>	
<b>Chapter 3</b>	<b>UPS Interface</b>	
	Model 825/800 .....	3-1
	Model 850/875, 1200/1600 .....	3-4
<b>Chapter 4</b>	<b>UPS Installation Comments</b>	
<b>Chapter 5</b>	<b>Notes, Cautions and Warnings</b>	

## List of Figures

### Chapter 3    UPS Interface

---

Figure 3-1	Electrical Interface on 825 Power Control Board .....	3-2
Figure 3-2	Model 825 -- UPS Alarms Driving System Alarms separately .....	3-3
Figure 3-3	Model 825 -- UPS LOW.BATTERY Alarm Driving <i>both</i> System Alarms.....	3-4
Figure 3-4	Electrical Interface on 850 Power Control Board .....	3-5
Figure 3-5	Model 850 -- UPS LOW.BATTERY Alarm.....	3-6

## List of Tables

### Chapter 2      UPS Environmental and Electrical Guidelines

---

Table 2-1	Environmental Restrictions for the UPS .....	2-2
Table 2-2	Battery and Backup Characteristics for the UPS .....	2-2
Table 2-3	Electrical Specifications for the UPS .....	2-3

### Chapter 3      UPS Interface

---

Table 3-1	825 UPS Interface Pin Description .....	3-1
Table 3-2	UPS.PRES* and SD.IMM* Alarm Interface .....	3-2
Table 3-3	850 UPS Interface Pin Description .....	3-5

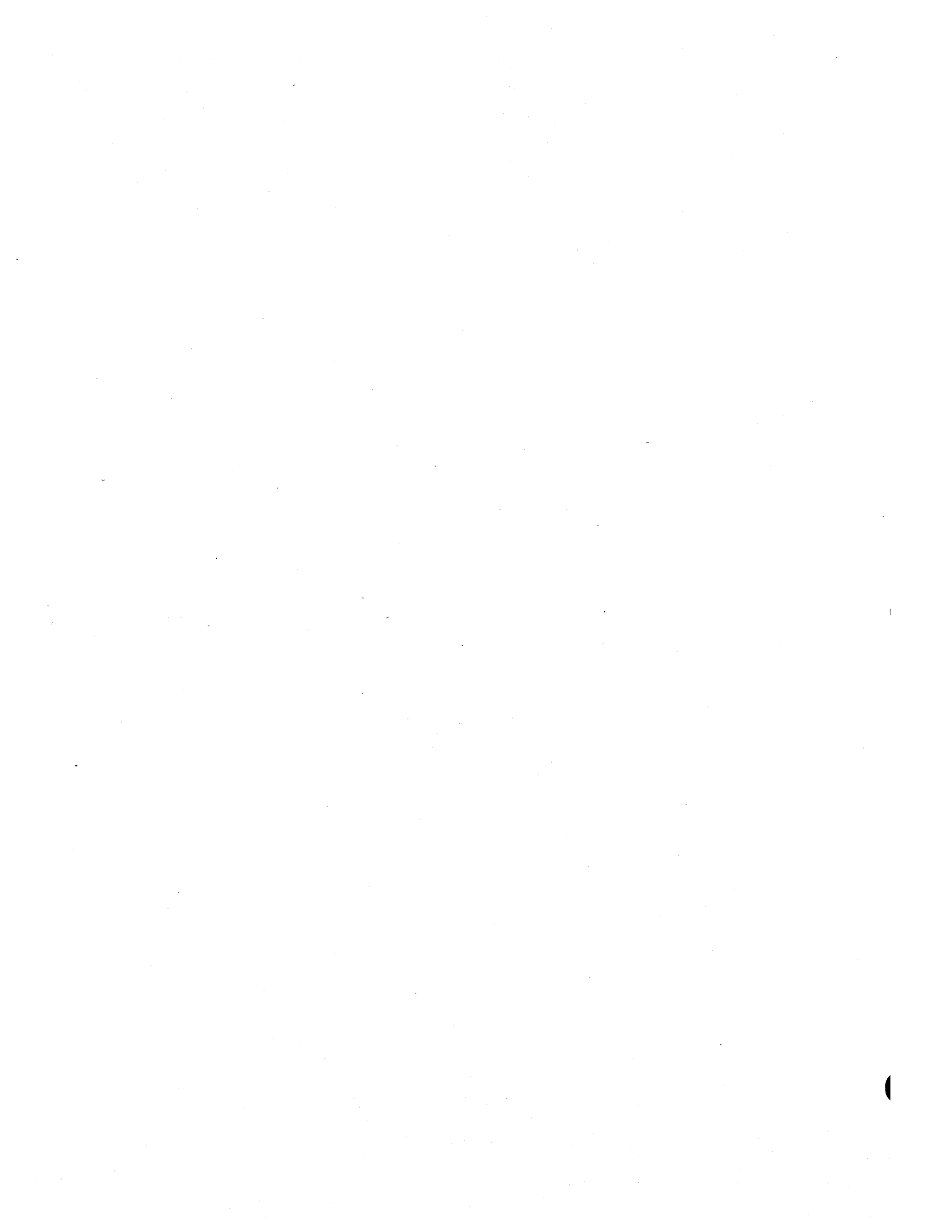

# *Introduction*

An Uninterruptible Power Supply (UPS) provides constant AC power to a computer system in the event of a blackout, brownout, or severe voltage fluctuation. This document is intended to assist ARIX customers in their selection and integration of a UPS product for use with ARIX systems. It describes guidelines for a UPS used with the following ARIX A1000 series of systems:

- Model 825 and Model 800
- Model 850, 875, 1200 and 1600

All references to the Model 825 apply equally to the Model 800.

All references to the Model 850 apply equally to the Models 875, 1200 and 1600.

Section 2 contains UPS environmental and electrical guidelines.

Section 3 contains guidelines for and describes the UPS signal interface.

Section 4 contains guidelines for UPS installation.

Section 5 contains notes, cautions and warnings about UPS installations.

## ***UPS - General Information***

A UPS provides protection against failed power, out of range power (too high or too low), electrical noise, and voltage surges. A UPS connects between the utility company's electrical power source and the computer system's power supplies, thus protecting the system electrical load. A UPS typically includes batteries, battery charger, a voltage inverter, and a transient suppressor and filter network. Some UPS models combine the features of a power conditioner with those of a UPS by including dynamic power conditioning, which regulates the output voltage and isolates the load from the AC input line by means of an isolation transformer. Because it can substantially improve the the long term reliability and availability of the computer system, ARIX recommends that a UPS with power conditioning be used.

During normal operation when utility power is available, the battery charger keeps the batteries fully charged. When the UPS detects the electrical utility's AC output voltage is outside the nominal range, the UPS draws energy from its batteries to provide AC power to the load. The switch-over occurs rapidly and the protected system experiences no noticeable loss of AC power. Even with a sudden blackout, the time from "detect" to "switch" must be less than two milliseconds.

Batteries must provide power for a minimum of ten minutes. This ten minute minimum allows time for an orderly system shutdown. An alarm signal is sent to the system when the batteries are running low, and the alarm state triggers the system to begin power failure shutdown procedures.

When the utility line voltage returns to a usable level, a line voltage monitor in the UPS starts the battery charger and recharges the batteries. Many UPS systems let you install extra batteries to extend the system running time beyond the ten-minute minimum.

The duration of backup battery power depends on the rating of the UPS, the number of batteries installed, the magnitude of the load, and whether the batteries are fully charged.

To increase the reliability of your computer system, the UPS should also protect the system from surges and noise by filtering and providing surge suppression for both common mode and transverse mode. This feature is not required, but is highly recommended.

UPS models with dynamic power conditioning usually switch to the inverter at variances of +20% or -20% from nominal. Such models also provide the additional protection of an output isolation transformer that eliminates direct electrical connection between the load and the AC input line and greatly improves common-mode noise attenuation.

**CAUTION:**

**Read this entire manual before beginning a UPS installation based upon these application guidelines.**



# UPS Environmental and Electrical Guidelines 2

Use the following information to ensure that a UPS used with an ARIX A1000 system meets the recommended guidelines.

## CAUTION

The ARIX Model 825 may be configured to operate at a nominal line voltage of either 110 VAC or a 220 VAC. The local utility line power determines the required input and output frequencies. Always check that the UPS and the Model 825 are configured properly for the applicable AC output.

The following guidelines apply equally to the ARIX Model 825, 800, 850, 875, 1200 and 1600 *unless otherwise noted*.

The guidelines noted here for the UPS are, in many instances, identical to the specifications for the ARIX computer system. Therefore, if your ARIX computer is being operated outside of its specifications, the UPS will likely also be operating outside of these guidelines. This variance from the specification should be taken into account when purchasing, installing, and operating the UPS.

The actual time that the UPS can support the system on batteries is dependent upon the load on the UPS and the capacity of the batteries. With the UPS properly sized for the load (correct KVA rating), the support time can be extended with the addition of more batteries to the UPS.

The actual time required to produce an orderly system shutdown will vary with the system configuration and workload. ARIX recommends that you test your configuration, and verify that sufficient battery power is available to complete a system shutdown.

All references to the Model 825 apply equally to the Model 800.

All references to the Model 850 apply equally to the Models 875, 1200 and 1600.

Table 2-1 details environmental restrictions for an uninterruptible power supply. Table 2-2 details battery and backup characteristics. Table 2-3 details electrical specifications.

If you plan to have the UPS support a peripheral expansion cabinet as well as the system cabinet, you must add the power required by the devices in the expansion cabinet to the power required by the system cabinet to calculate the total power the UPS is required to provide.

**Table 2-1 Environmental Restrictions for the UPS**

Ambient Temperature	10°C to 40°C (Operating)
Relative Humidity	95% maximum (non-condensing)
Elevation	1500 meters (at 40°C ambient, full load without derating)
Audible Noise (at 1 meter)	55 dBA maximum in backup mode

**Table 2-2 Battery and Backup Characteristics for the UPS**

<b>Battery</b>	
Type	Sealed, Maintenance free
Life Expectancy	200 full discharge cycles at full load
Recharge Time	12 Hours maximum
Additional Running Time	Add extra battery packs
<b>Backup</b>	
Transfer Time	2 msec. maximum after AC Input Line failure
Minimum Backup Time	10 minutes after low battery alarm (Verify with your configuration).

**Table 2-3 Electrical Specifications for the UPS**

<b>AC Input</b>	
Voltage Range *	+10,-20% of nominal line
Frequency	50 or 60 Hz as required, single phase
<b>AC Output</b>	
Power (after all deratings applied)	1.5 KVA Model 825 2.2 KVA Model 850
Voltage * In Backup Mode In Standby Mode	±5% of nominal ±10 (with power conditioning)
Frequency In Backup Mode In Standby Mode	Single phase 50 or 60 Hz, ±1 Hz Single phase 50 or 60 Hz, Sync to 0.1% of line frequency
Frequency Slew Rate	±1 Hz/second
Harmonic Distortion (voltage)	5% total maximum for power factors 2% maximum single with linear load 10% maximum single with non-linear load
Power Factor	.9 lagging to .9 leading without derating
Load Crest Ratio (current)	3:1 minimum without derating (must handle 4:1 after derating)
Output Overload	125% for 1 minute 200% for 10 cycles
Load Transient Response	±8% for 100% step load change, recover to ±2% within 100 msec.
Transfer time to Inverter Power after power failure	Less than 2 milliseconds
<b>Power Conditioning Noise Attenuation (recommended)</b>	
Common Mode	45 dB at 100 KHz
Transverse Mode	45 dB at 100 KHz

\* Nominal voltages: Model 825 110 or 220 VAC (factory configured)  
Model 850 220 VAC ONLY

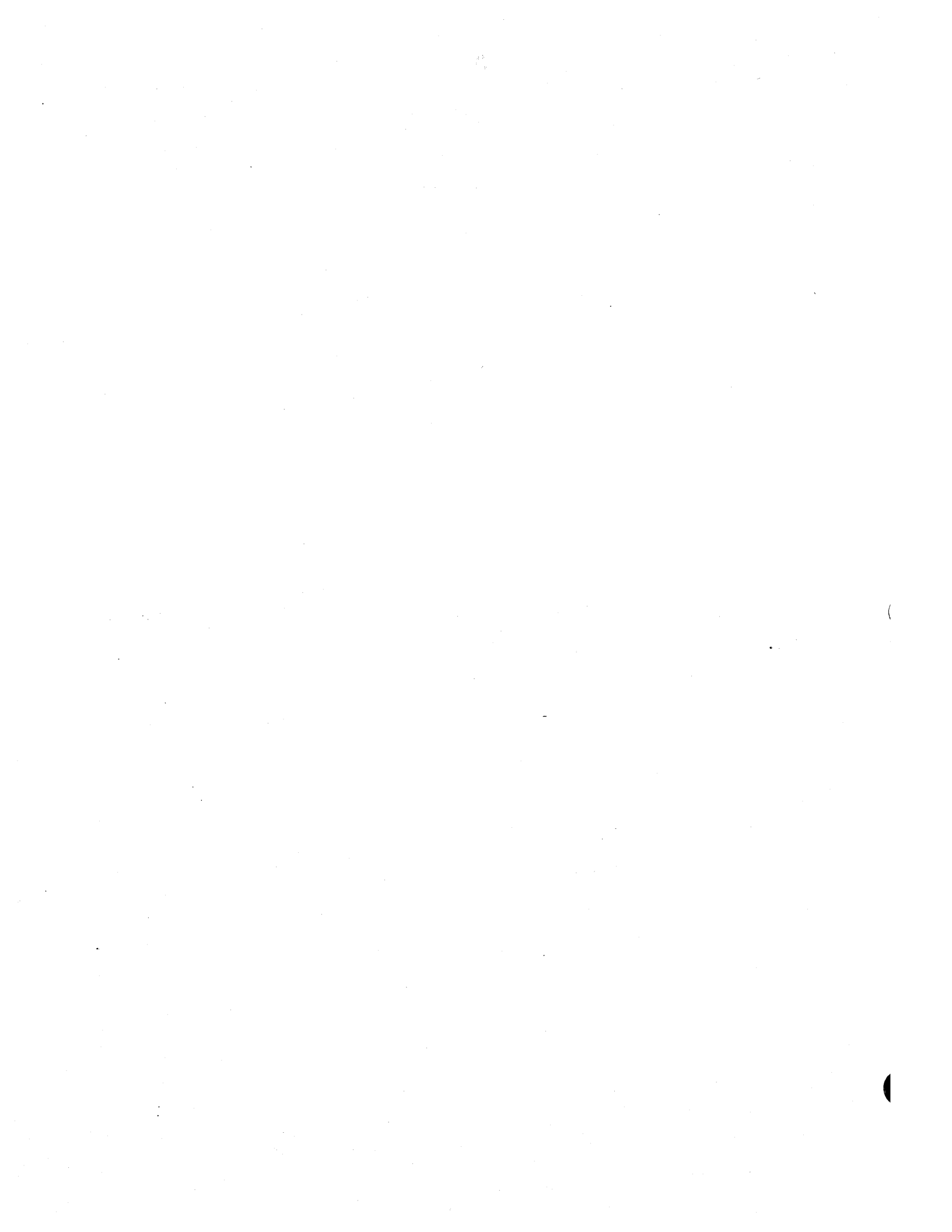

# UPS Interface 3

Due to the major effect an alarm from the UPS causes, the cable carrying the alarm signal to the processor cabinet *must* be shielded. This will prevent spurious electrical noise from inducing a false alarm. The UPS interface connector is located on the rear panel of the processor cabinet.

## Model 825/800

Two signals are used in the Model 825 UPS interface: UPS.PRES\* (UPS present, low true) and SD.IMM\* (shutdown imminent, low true). When *both* signals are true (low), an interrupt is asserted and shutdown procedures begin. Both signals *may* be driven by the UPS's low battery indicator, or UPS.PRES\* may be driven by the UPS AC.FAIL signal and SD.IMM\* may be driven by the UPS LOW.BATTERY signal.

Table 3-1 lists the UPS interface signals and pin assignments for the Model 825.

Table 3-1 825 UPS Interface Pin Description

Pin Number	Signal Name	Connection
1	NC	none
2	UPS.PRES*	AC.FAIL relay contact or opto-isolator collector
3	ON.BYPASS	none
4	UPS.OFF	none
5	SD.IMM*	LOW.BATTERY relay contact or opto-isolator collector
6	Not Used	none
7	Common	Relay common or opto-isolator emitter
8	Not Used	none
9	Not Used	none

NC = No Connection

**Table 3-2 UPS.PRES\* and SD.IMM\* Alarm Interface**

Component Type	Indication
<p>*1 form A contact relay (Normally Open)</p> <p>or</p> <p>*1 opto-isolator transistor (Normally OFF)</p>	<p>When contacts close (or transistor turns on) this indicates:</p> <p>Low battery, 5 minutes remaining and/or AC line failure, backup in use</p>

\* Use either a relay or opto-isolator transistor; whichever component is used it must handle 20 milliamps minimum. The alarm state (relay contacts closed or opto-isolator transistor ON) causes the computer to begin power failure shutdown procedures.

The interface circuit in the Model 825 is an opto-isolator. The UPS alarm driver must be able to sink 15 mA of current through each of the opto-isolator's LEDs (pins 2, 5) to common (pin 7). Figure 3-1 shows the electrical interface for each of the two signals.

**Figure 3-1 Electrical Interface on 825 Power Control Board**

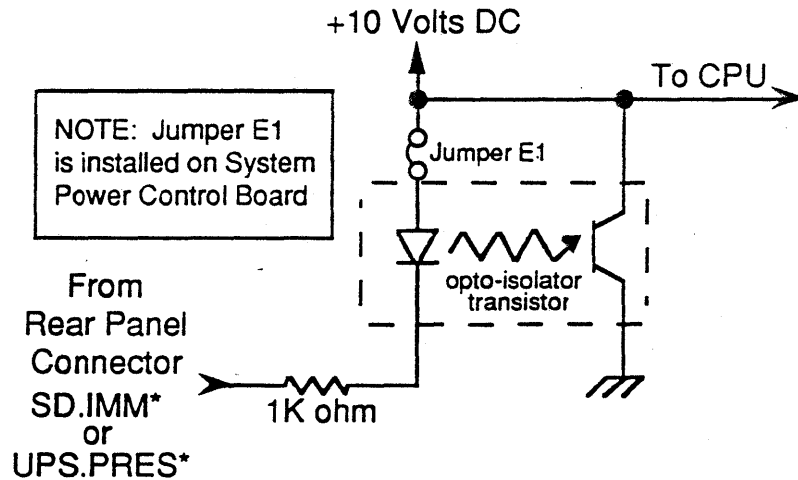

Usually the system's UPS.PRES\* alarm is driven by the UPS's AC.FAIL alarm, and the system's SD.IMM\* alarm is driven by the UPS's LOW.BATTERY alarm (see Figure 3-2).

Another possibility is that *both* UPS.PRES\* and SD.IMM\* are driven from the UPS's LOW.BATTERY alarm (see Figure 3-3).

Whichever interface connection you have, UPS.PRES\* must be true when the LOW.BATTERY alarm is true.

The LOW.BATTERY alarm signal must occur at least ten minutes before the UPS system batteries drain to the point that the UPS shuts itself down. This ensures that the processor has sufficient time to write buffers out to the disk(s) and perform any other pre-defined power fail shutdown tasks. After the processor has completed its shutdown tasks it will turn its own power off.

Figure 3-2 illustrates a possible UPS cable connection with an ARIX Model 825. The UPS's LOW.BATTERY and AC.FAIL signals are shown separately driving the two system alarms using relays (opto-isolator transistors could be used as well).

**Figure 3-2 Model 825 -- UPS Alarms Driving System Alarms separately**

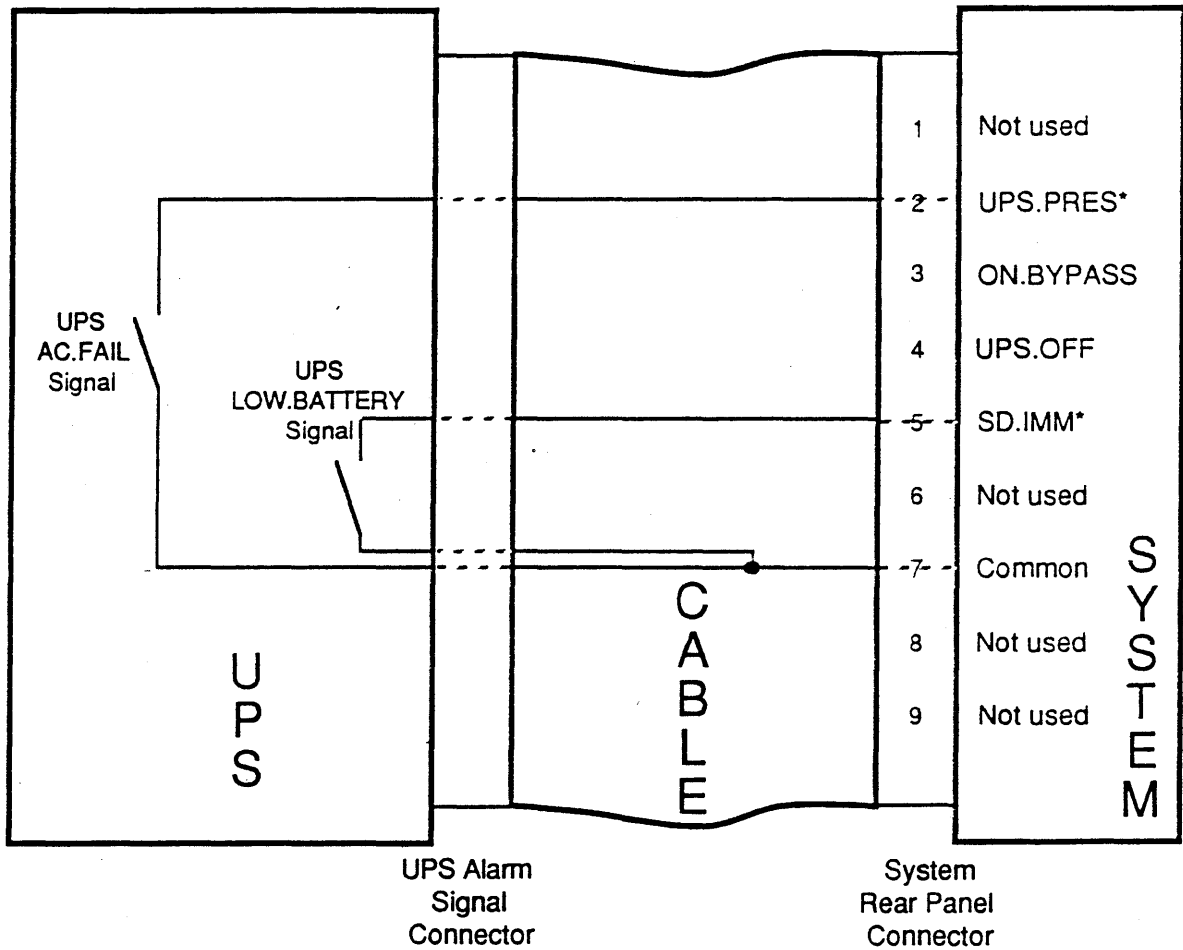
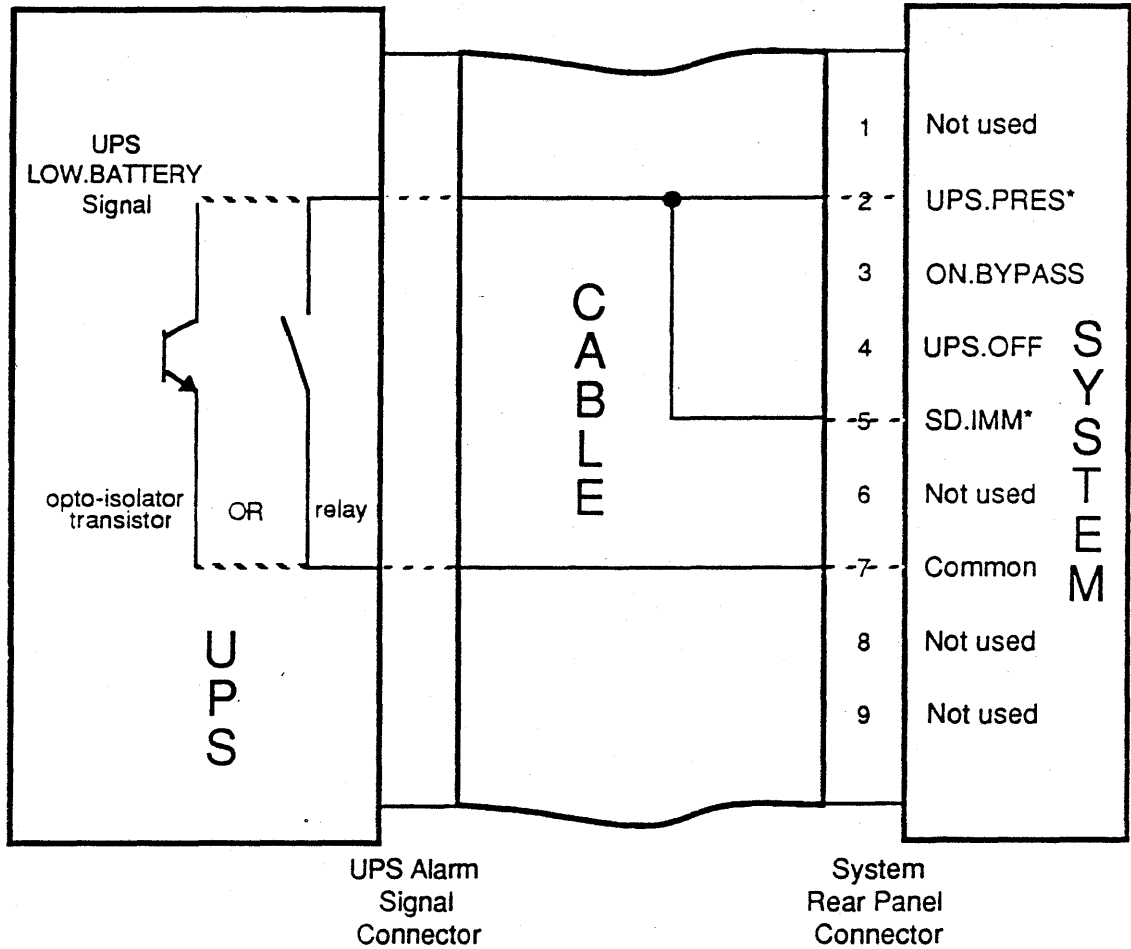

Figure 3-3 illustrates a possible UPS cable connection with an ARIX Model 825. The UPS's LOW.BATTERY signal is shown driving both system alarms using *either* an opto-isolator transistor or a relay.

**Figure 3-3 Model 825 -- UPS LOW.BATTERY Alarm Driving both System Alarms**



**Model 850/875, 1200/1600**

Two signals are used in the Model 850 UPS interface: `ups_present*` and `shutdown_imm*`. `ups_present*` is jumpered to common and is, therefore, always true (low) when the interface cable is installed. When `shutdown_imm*` is true (low), an interrupt is asserted and shutdown procedures begin. `shutdown_imm*` is driven by the UPS's low battery indicator.

The UPS connector on the rear panel of the system cabinet is a male or female DB-9 connector. Machines manufactured prior to 7 August 1987 use a female DB-9 connector on the rear panel. Machines manufactured on or after 7 August 1987 will have a male connector on the rear panel. Table 3-4 provides a pin out description.



**Table 3-3 850 UPS Interface Pin Description.**

Pin Number	Signal Name	Connection
1	Common	none
2	Common	LOW.BATTERY relay common or opto-isolator emmitter
3	Common	Pin 8
4	-	none
5	-	none
6	-	none
7	shutdown_imm*	LOW.BATTERY relay contact or opto-isolator collector
8	ups_present*	Pin 3
9	-	none

The Model 850 interface is designed so that a dry relay contact or opto-coupler in the UPS can provide the alarm signal to the computer system. The alarm signal provided to the computer system is active low and must pull the shutdown\_imm\* line (pin 7) to within 0.8 volts DC of the common line (pin 2). Figure 3-4 illustrates the Model 850's electrical interface to the UPS alarm signal utilizing a low battery alarm relay.

Maximum current demand through the relay contact is 0.4 mA. The signal is received by a 74LS14 logic gate which has a 4.7 Kohm pull-up resistor to +5 Volts DC (Figure 3-4).

**Figure 3-4 Electrical Interface on 850 Power Control Board**

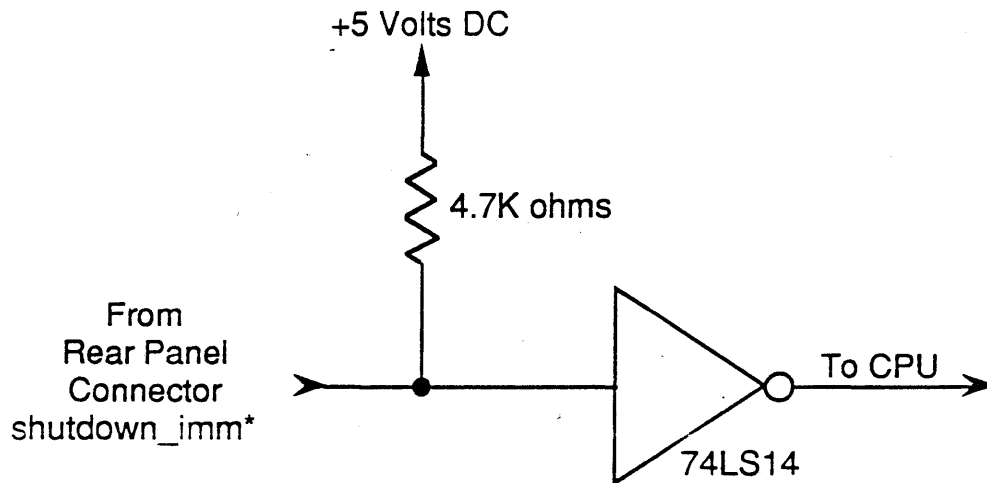

The low battery alarm signal must occur at least ten minutes before the UPS system batteries drain to the point that the UPS shuts itself down. This ensures that the processor has sufficient time to write buffers out to the disk(s) and perform any other pre-defined power fail shutdown tasks. After the processor has completed its shutdown tasks it will turn its own power off.

Figure 3-5 illustrates a possible UPS cable connection with an ARIX Model 850. The UPS's LOW.BATTERY signal is shown driving the system shutdown\_imm\* alarm using either an opto-isolator transistor or a relay (ups\_present\* is always low due to its internal cable connection to Common).

**Figure 3-5 Model 850 -- UPS LOW.BATTERY Alarm**

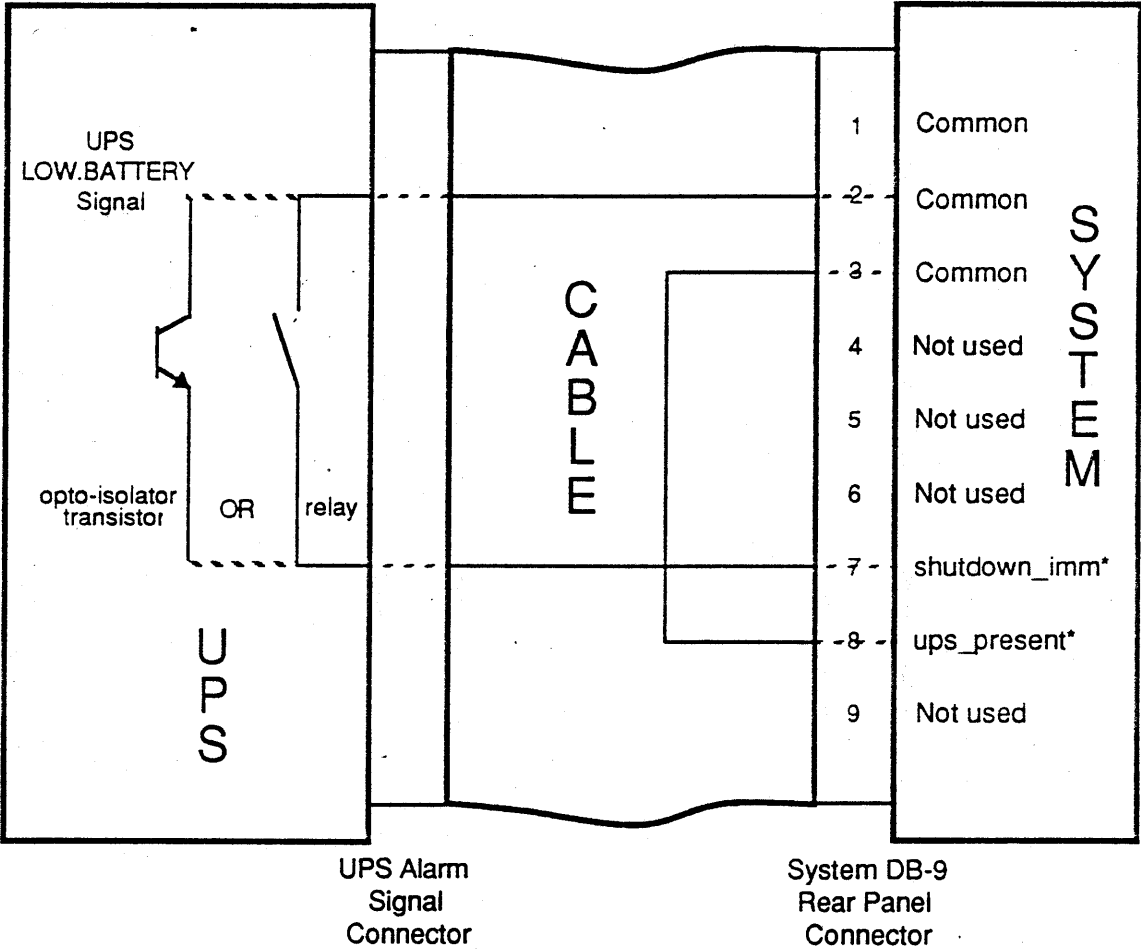

# *UPS Installation Comments*

4

For information about ARIX A1000 system components, refer to ARIX system's Installation and Maintenance Guide.

A UPS installation typically requires certain clearance minimums for proper accessibility and ventilation. Also, install the UPS away from excessive dust and chemical fumes. Check the UPS manufacturer's manuals for warranty or other particulars regarding normal operation and proper application of uninterruptible power supplies.

Common safety requirements include the following:

- An AC input line circuit breaker
- A DC battery circuit breaker or fuse
- An AC output line circuit breaker

A UPS installation should meet any local safety requirements.

Before installing a UPS, inspect it for possible defects. Follow the manufacturer's recommendations for reporting any suspected damage or defect.



# *Notes, Cautions and Warnings*

5

This section contains notes, cautions, and warnings that apply to all UPS installations. Always follow the manufacturer's recommended safety precautions for any electrical equipment.

Whenever installing electrical equipment such as an ARIX computer system or an uninterruptible power supply (UPS), be sure that the UPS voltage and power rating match the available line voltage and load requirements. Also be sure that the UPS output voltage matches the computer system requirements.

## **CAUTION**

**Turn OFF the AC input circuit breaker and all battery circuit breakers and unplug the AC input cord of the UPS before changing or making any connections.**

Follow the UPS manufacturer's instructions when installing or using a UPS, plugging in battery cables, connecting the AC input to a utility outlet, or connecting the UPS into the system load.

## **NOTE**

**In case of a prolonged power shutdown, such as a regular evening or weekend power shutdown in the building, always switch the UPS OFF.**

When utility power is shut off, the UPS reacts the same as if a power failure occurred and begins supplying backup power. Unless it is switched off, the UPS will run until the batteries discharge completely.

## CAUTION

**The UPS ON/OFF switch should be OFF whenever the UPS is not connected to the power line. If the switch is left on, the batteries will slowly drain. Leaving the UPS in this condition for an extended period could permanently damage the batteries.**

Normal running of a UPS keeps it fully recharged. The maximum recharging period after using the battery-activated inverter to supply power to the system can be up to 12 hours. Before storing a UPS, fully charge the batteries by leaving it plugged in and turned on for at least 12 hours. Avoid permanent battery damage by storing batteries at room temperature. Freezing or overheating can damage batteries.

Internal reactions in batteries cause a slow self-discharge even at room temperature. Avoid high temperatures, and store batteries at lower temperatures for longer storage life. For fullest capacity and longer life, repeat the recharging process on any batteries stored for over 60 days (or as often as recommended by the manufacturer).

## NOTE

**Double check that the battery circuit breakers are turned off before storing UPS batteries.**

Handling, especially shipping, batteries requires particular care. Troubleshooting a UPS is recommended for qualified technicians only.

## WARNING

**Batteries have a high short-circuit capacity. Mistakes in connecting or disconnecting may cause an arc or weld that could result in severe burns. Always use eye protection when working with batteries.**

Always follow the UPS manufacturer's instructions when installing a UPS.

REV	BY	DATE	DESCRIPTION
1			
2			
3			
4			
5			
6			
7			
8			
9			
10			

DRAWING NO. **AD-009468**  
 PART 2 OF 2  
 TITLE: **FINAL ASSEMBLY, MAXI, 1.56 MB**  
 SCALE: **1/4"**  
 DATE: **1977**  
 DESIGNED BY: **XEROX**  
 DRAWN BY: **XEROX**  
 CHECKED BY: **XEROX**  
 APPROVED BY: **XEROX**  
 PARTS LIST: **XEROX**  
 MATERIALS: **XEROX**  
 TOLERANCES: **UNLESS OTHERWISE SPECIFIED: FRACTIONAL DIMENSIONS: DECIMALS: 0.0050 INCHES**  
 DIMENSIONS IN PARENTHESIS: **SCALE 1/4"**

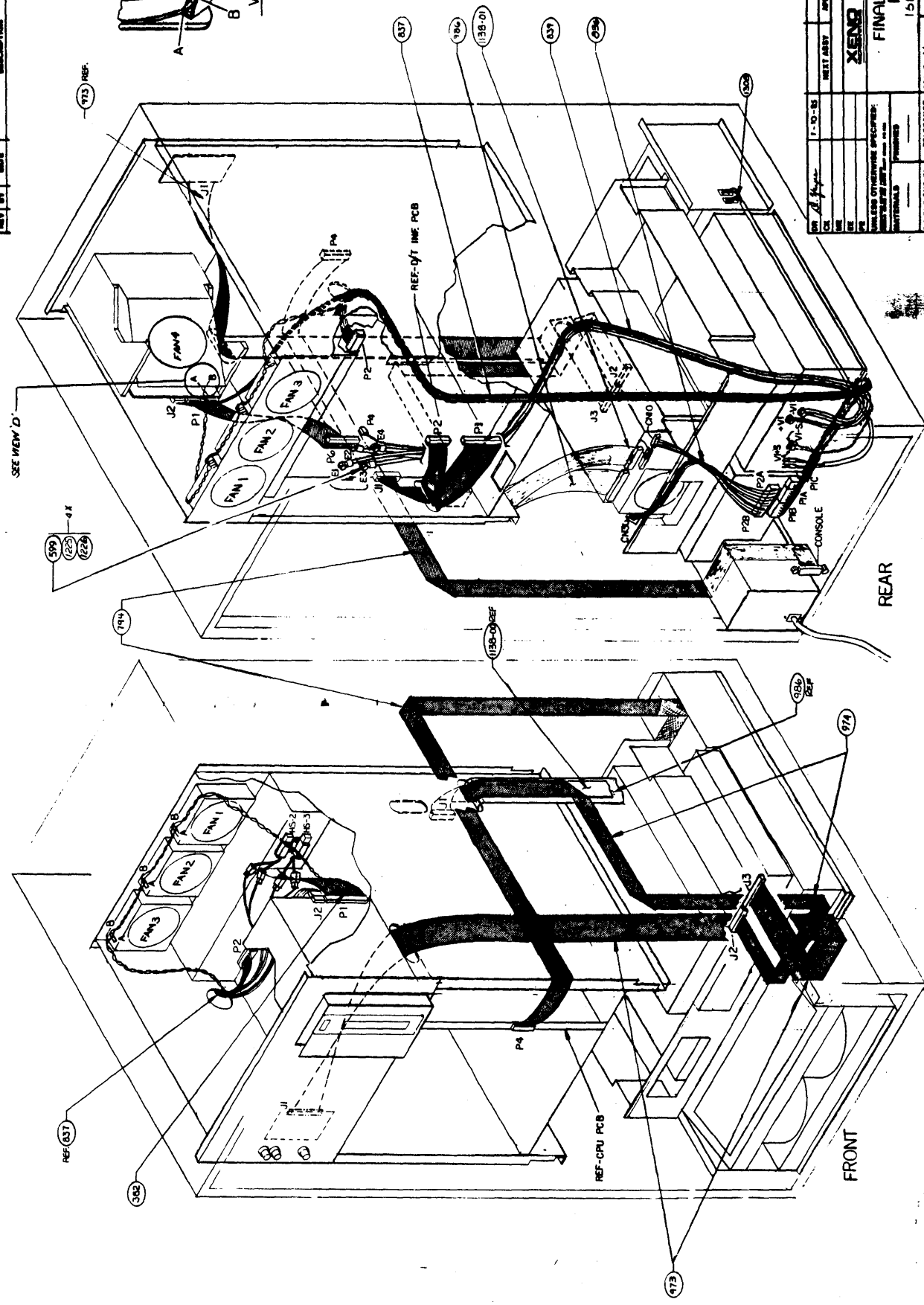
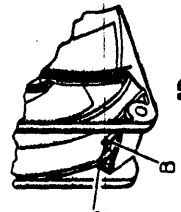

D C B A





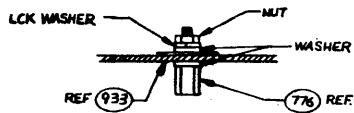

SECTION C-C

SCALE: 2X

MTG HOLES SUPPLIED WITH KIT  
2 PLACES

FRONT (DOOR REMOVED)

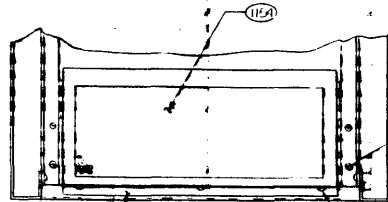
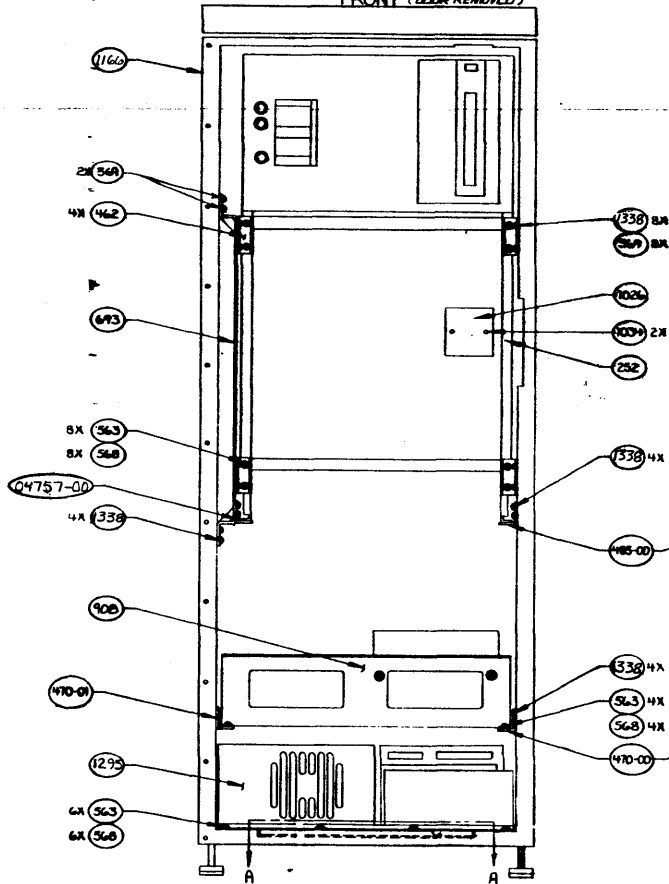

SECTION AA

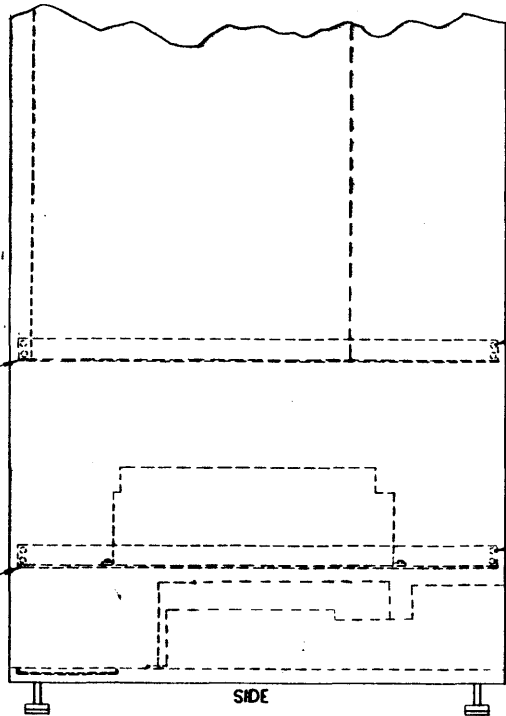

SIDE

REV		DATE	DESCRIPTION	APPROV	DATE
B	2X	JAN 85	PRODUCTION RELEASE PER ECD 0184		2-26-85
C	FEA	4 OCT 85	REVISED PER ECD #293		4-15-85
D	CC	1-8-86	DESIGN CHANGE PER ECD 0370		1/29/86
E	CE	4-7-86	REVISED PER ECD 0422		4-11-86
F	CC	4-18-86	REVISED PER ECD 0454		4-23-86
H	M	3-2-89	REVISED PER ECD #1118		3-11-89
J	CMA	6-19-89	REVISED PER ECD #1273		6-22-89
K	CMA	8-18-89	REVISED PER ECD #1400		8-18-89
M	CM	12-28-90	INACTIVE PER ECD #1910		12/28/90

REAR (UPPER DOOR REMOVED)

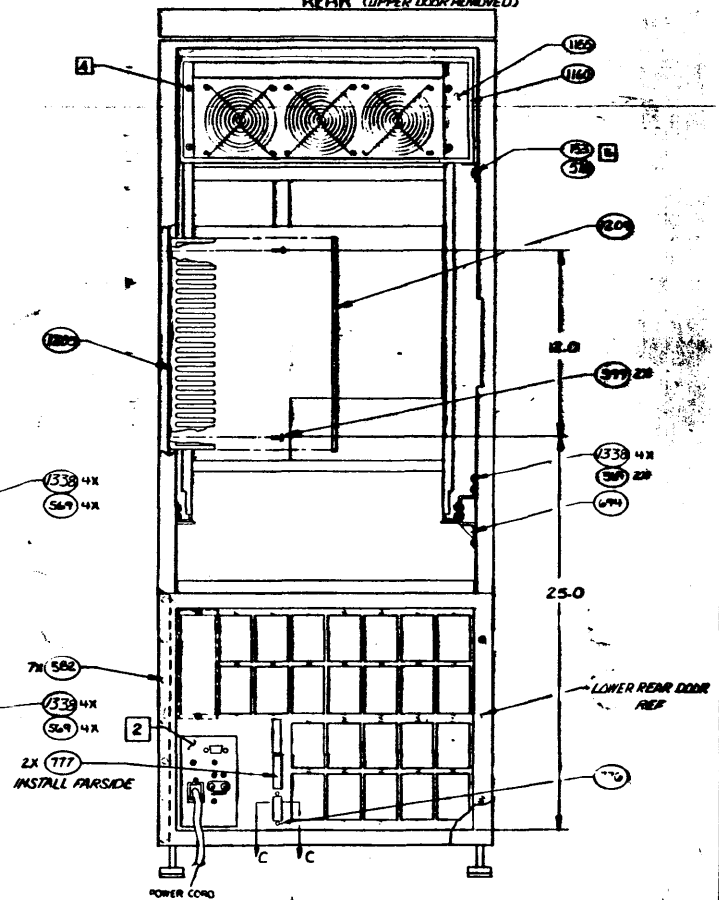

NOTES:

- 1 FOR FASTENER TORQUE SPECIFICATION, SEE PR-77065
- 2 SEE ZONE B3 - THIS SURFACE OF A.C. DIST./PWR SUPPLY ASSY TO BE FLUSH WITH OUTSIDE CORNER OF CABINET.
- 3 BEST METHOD OF HARNESS/CABLE ROUTING/DRESSING TO BE DETERMINED BY MFG. SECURE HARNESS/CABLES USING CABLE TIE (591), CABLE TIE MOUNT OR FLAT CABLE CLAMP (67) WHERE NEEDED. FOR PROTECTION AGAINST SHARP EDGES USE GROMMET STRIP (59) OR (70) WHERE NEEDED.

- 4 USE EXISTING HARDWARE (4 PLS)
- 5 USE PLENUM TAB AS A LOCATOR FOR DRILLING A .156 DIA HOLE IN CABINET.

REV	DATE	DESCRIPTION	APPROV	DATE	PR/CHK	REV
1	7-85					
<b>XENQ</b>						
<b>FINAL ASSEMBLY</b>						
<b>MAXI</b>						
<b>1.05 ME</b>						
SCALE: 1:1						
REV: AD-00968						



WD-00962 C/INA  
 MAIN WIRING DIAG, MAXI

SHT 1 OF 1

REV	DATE	BY	DESCRIPTION
1	10/1/73	WJ	INITIAL ISSUE
2	10/1/73	WJ	REVISION
3	10/1/73	WJ	REVISION
4	10/1/73	WJ	REVISION
5	10/1/73	WJ	REVISION
6	10/1/73	WJ	REVISION
7	10/1/73	WJ	REVISION
8	10/1/73	WJ	REVISION
9	10/1/73	WJ	REVISION
10	10/1/73	WJ	REVISION
11	10/1/73	WJ	REVISION
12	10/1/73	WJ	REVISION
13	10/1/73	WJ	REVISION
14	10/1/73	WJ	REVISION
15	10/1/73	WJ	REVISION
16	10/1/73	WJ	REVISION
17	10/1/73	WJ	REVISION
18	10/1/73	WJ	REVISION
19	10/1/73	WJ	REVISION
20	10/1/73	WJ	REVISION

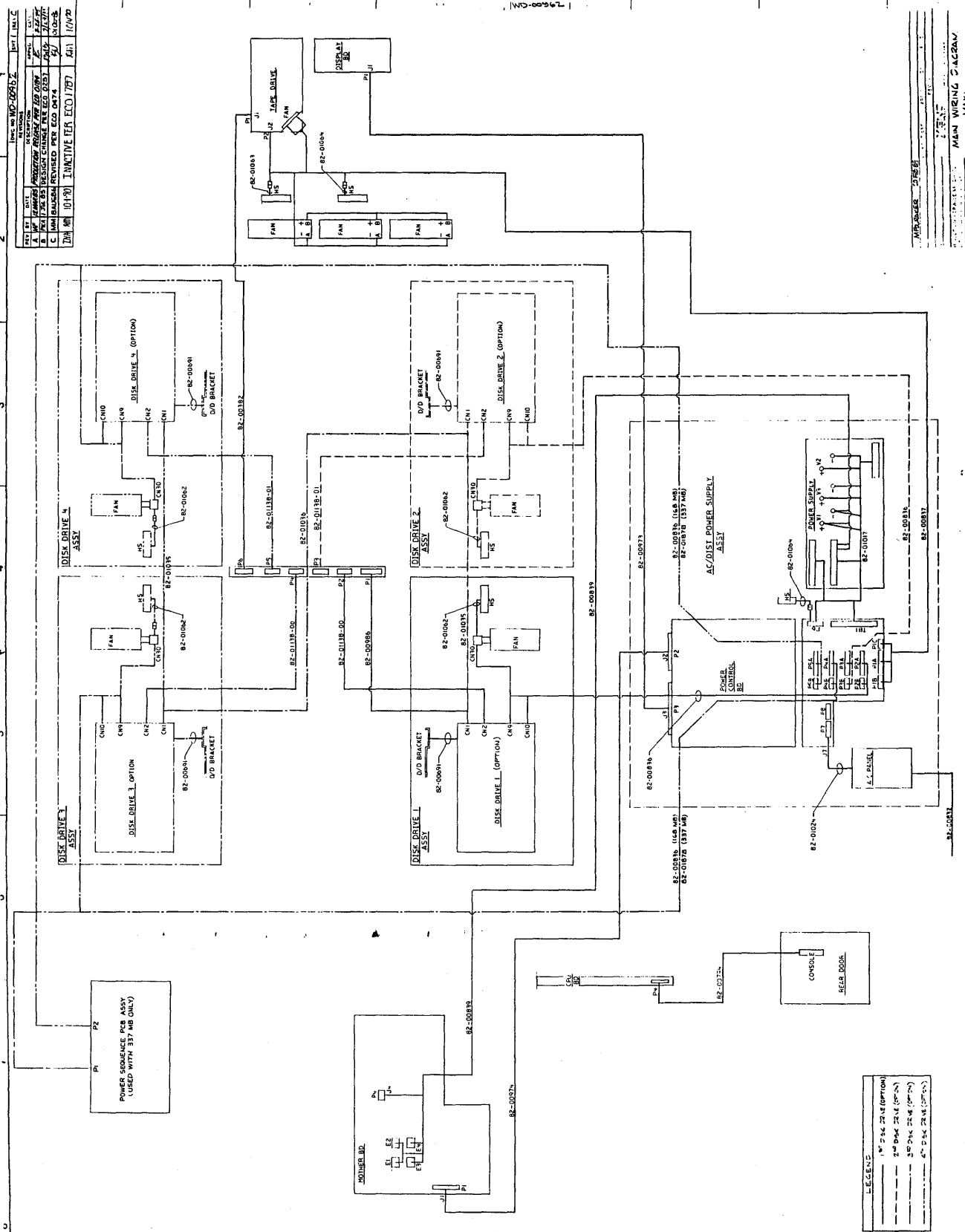

LEGEND

---	1" 24K 27K (OPTION)
---	2" 24K 27K (OPTION)
---	3" 24K 27K (OPTION)
---	4" 24K 27K (OPTION)

WD-00962  
 MAIN WIRING DIAGRAM



REV	NO	DATE	DESCRIPTION	APP'D	DATE	REV
A	1	1/14/87	PROD. REL. PER ECO # 0388			1/14/87
B	2	10/25/86	REVISED PER ECO # 0298			10/25/86
C	3	9-21-86	REVISED PER ECO # 0388			9/21/86
D	4	2-11-87	DESC CHG & ADD 'X' TO DNG NO PER ECO # 0120			2-18-87
INA	1	3/14/90	INACTIVE PER ECO # 1564A			3/14/90

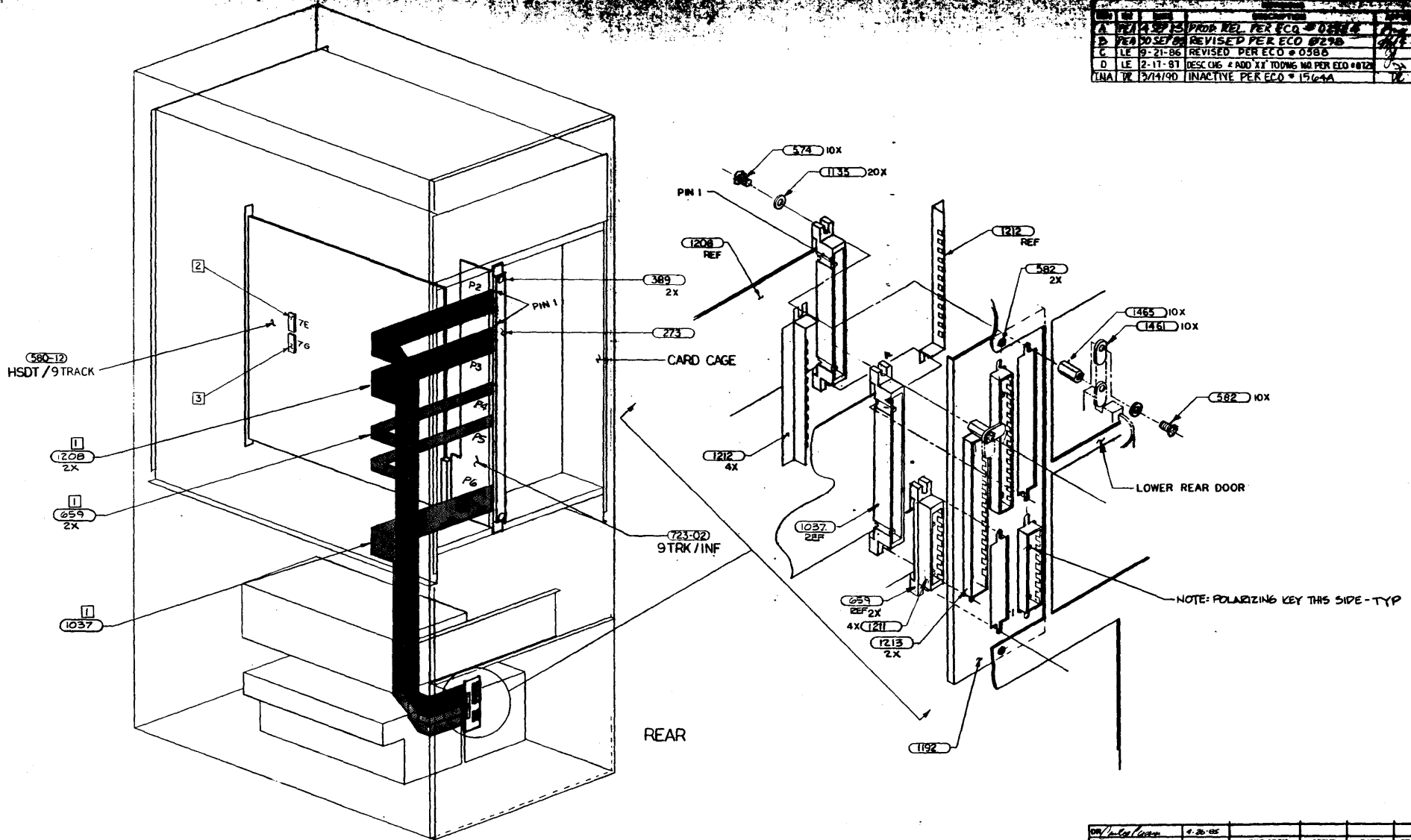

- NOTE:
- BEST METHOD OF CABLE ROUTING & DRESSING TO BE DETERMINED BY MFG. SECURE CABLES USING CABLE TIE (531) CABLE TIE MOUNT (538) OR FLAT CABLE CLAMP (767) WHERE NEEDED.
  - REPLACE 85-00606 WITH P/N 85-01318 IN LOCATION 7E & RETURN P/N 85-00606 TO STOCK.
  - REPLACE 85-00607 WITH P/N 85-01317 IN LOCATION 7G & RETURN P/N 85-00607 TO STOCK.

DR/INSTR/ISS	4-26-85	NEXT ASST	APP'D	DATE	PR/DCN	REV
CR						
MR						
DE						
PE						
UNLESS OTHERWISE SPECIFIED:		XERO				
MATERIALS		KIT, HSDT/SMD/9T				
FINISHES		W/ CABLE				
QUANTITY	TOLERANCE	SCALE NONE	D	REV NO.	8	
1	±				1K-01146-XX	

188-01146-XX 1



REV	BY	DATE	DESCRIPTION	APPRD	DATE
A	FEA	25 SEP 85	PRODUCTION RELEASE PER ECO 8297	DMY	9/24/85
B	DR	29 MAR 86	REV ROLL ONLY PER ECO 0538	DMY	3/27/86
INA	DL	14 MAR 90	INACTIVE PER ECO *1564A	DMY	3/14/90

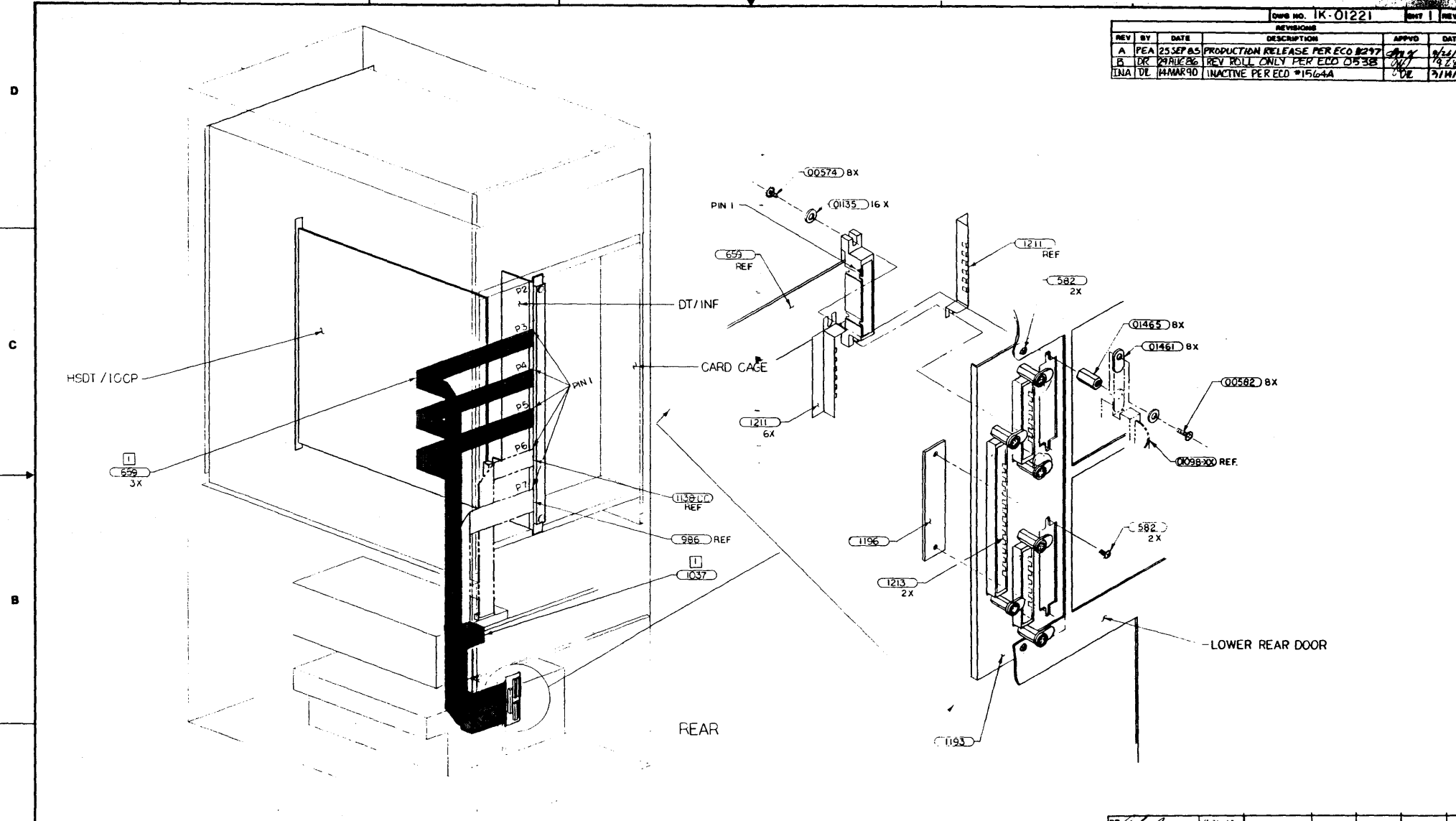

- NOTE:
- BEST METHOD OF CABLE ROUTING & DRESSING TO BE DETERMINED BY MFG. SECURE CABLES USING CABLE TIE (541) CABLE TIE MOUNT (593) OR FLAT CABLE CLAMP (767) WHERE NEEDED.
  - IDENTIFY KIT WITH PART NO. 88-01221.

DR	4/26/85				
CK					
ME					
EE					
PE					
REVISIONS					
<b>XERO</b>					
UNLESS OTHERWISE SPECIFIED:					
MATERIALS		FINISHES			
DIMENSIONS IN		TOLERANCE		SCALE NCNE	
D		1		D	
DWG NO.		PART NO.			
IK-01221		88-01221			





REV BY		DATE	DESCRIPTION	APPVD	DATE
A		FEA	25 SEP 85	PRODUCTION RELEASE PER ECO #297	7/26/85
INA		DL	14 MAR 90	INACTIVE PER ECO #1504A	2/14/90

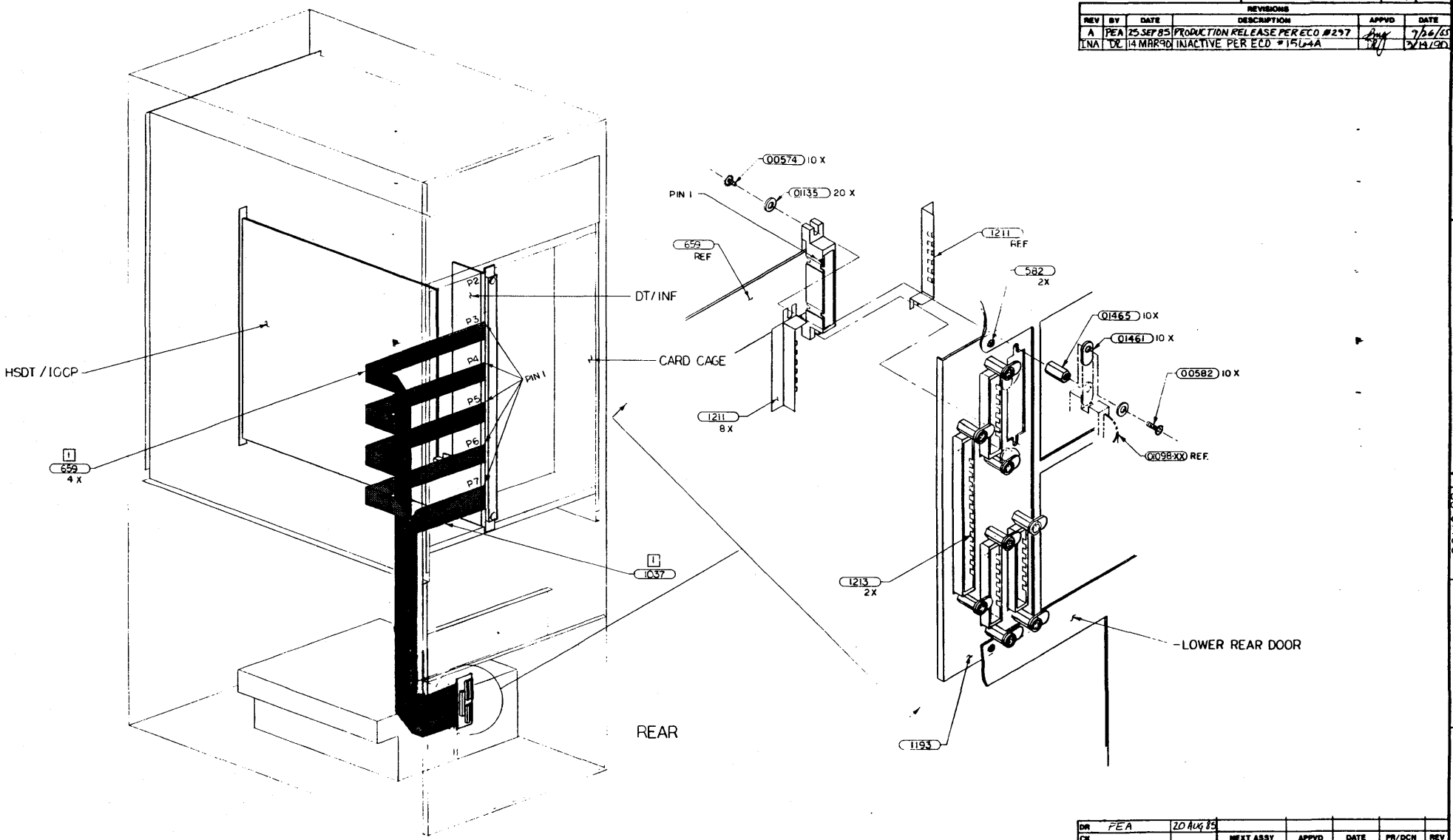

NOTE:

1 BEST METHOD OF CABLE ROUTING & DRESSING TO BE DETERMINED BY MFG. SECURE CABLES USING CABLE TIE (541) CABLE TIE MOUNT (598) OR FLAT CABLE CLAMP (767) WHERE NEEDED.

2 IDENTIFY KIT WITH PART NO. 88-01496.

DR	FEA	20 AUG 85				
CK			NEXT ASSY	APPVD	DATE	PR/DCN
EE			REVISIONS			
PE			<b>XERO</b>			
UNLESS OTHERWISE SPECIFIED:						
MATERIALS			FINISHED			
KIT, REMOTE / DISK I/O						
(SECOND DT/INF)						
DIMENSIONS IN	TOLERANCE	SCALE	NONE	DWG NO.		REV

88-01496



REV	BY	DATE	DESCRIPTION
A	MP	13 MAR 65	PRODUCTION RELEASE FOR ECD 1062
B	AP	23 OCT 65	REVISED PER RD # 0 1/2
C	DK	1 AUG 66	REVISED PER ECD # 1062

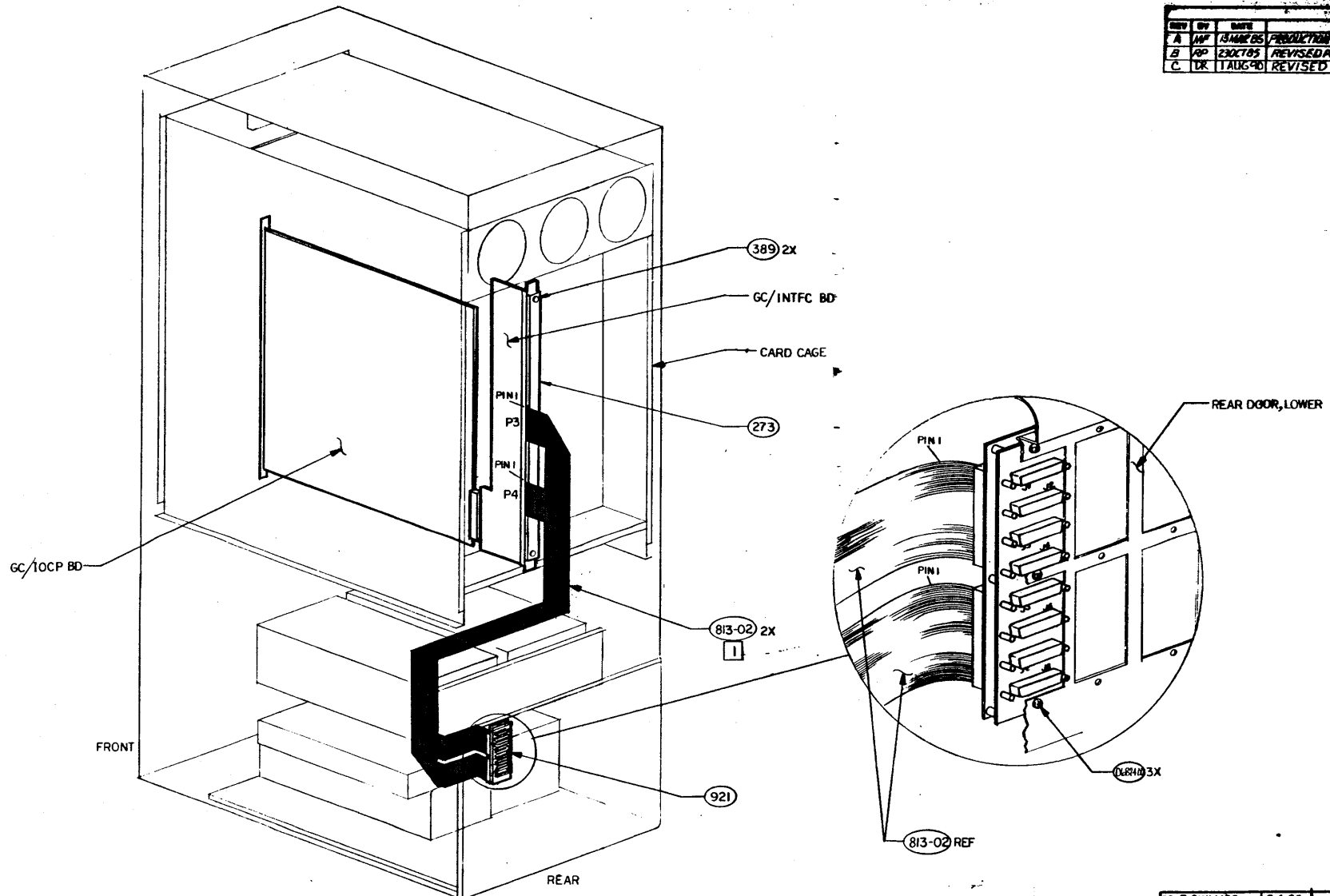

**NOTES;**  
**1** BEST METHOD OF CABLE ROUTING & DRESSING TO BE DETERMINED BY MFG. SECURE CABLES USING CABLE TIE (69), CABLE TIE MOUNT (69B) OR FLAT CABLE CLAMP (67) WHERE NEEDED.

DR	PHILLIPS	F-6-65	REVISED
CK			
SE			
PE			
PA			
UNLESS OTHERWISE SPECIFIED:			
MATERIALS FINISHES			
TOLERANCE			
SERIAL (MAX)			







REV	BY	DATE	DESCRIPTION	APPRD	DATE
A	MF	14 MAR 85	PRODUCTION RELEASE PER ECD 0184	RF	8-24-85
B	MF	21 MAY 85	REVISED PER ECD 0241	JT	5-27-85
C	RP	20 FEB 86	REVISED PER ECD 0353	YH	9-21-86
D	CC	3-18-86	REVISED PER ECD 0480	YH	7-3-86
E	RD	20 JUNE 86	REVISED PER ECD 0483	YH	7-15-86
F	LE	5-15-87	REVISED PER ECD # 0785	DA	6-4-87
H	RP	8-12-87	REVISED PER ECD # 0806A	DA	1-4-88
TWA	DL	1-8-91	INACTIVE PER ECD #1829	DL	1-8-91

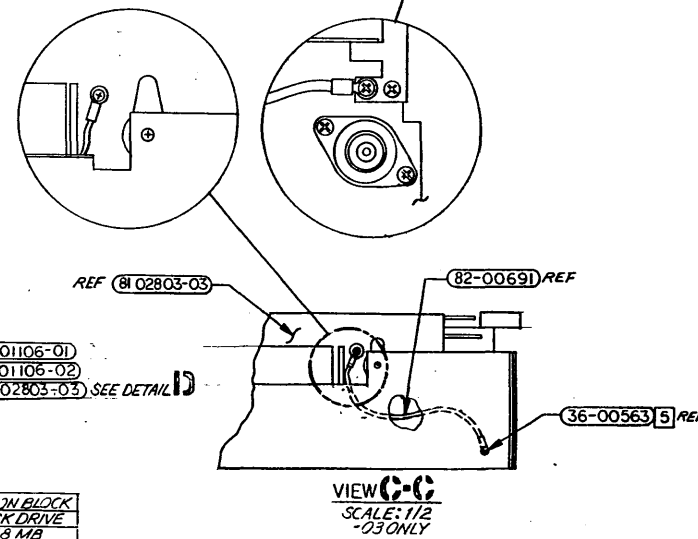
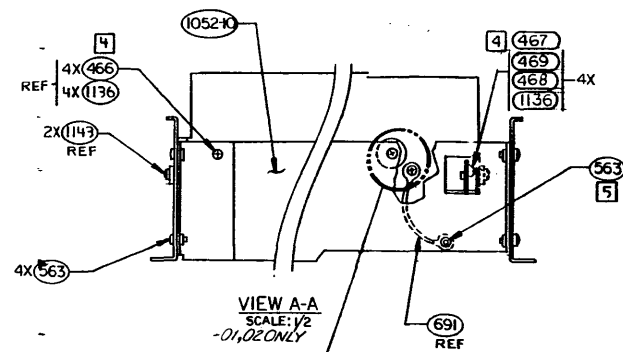
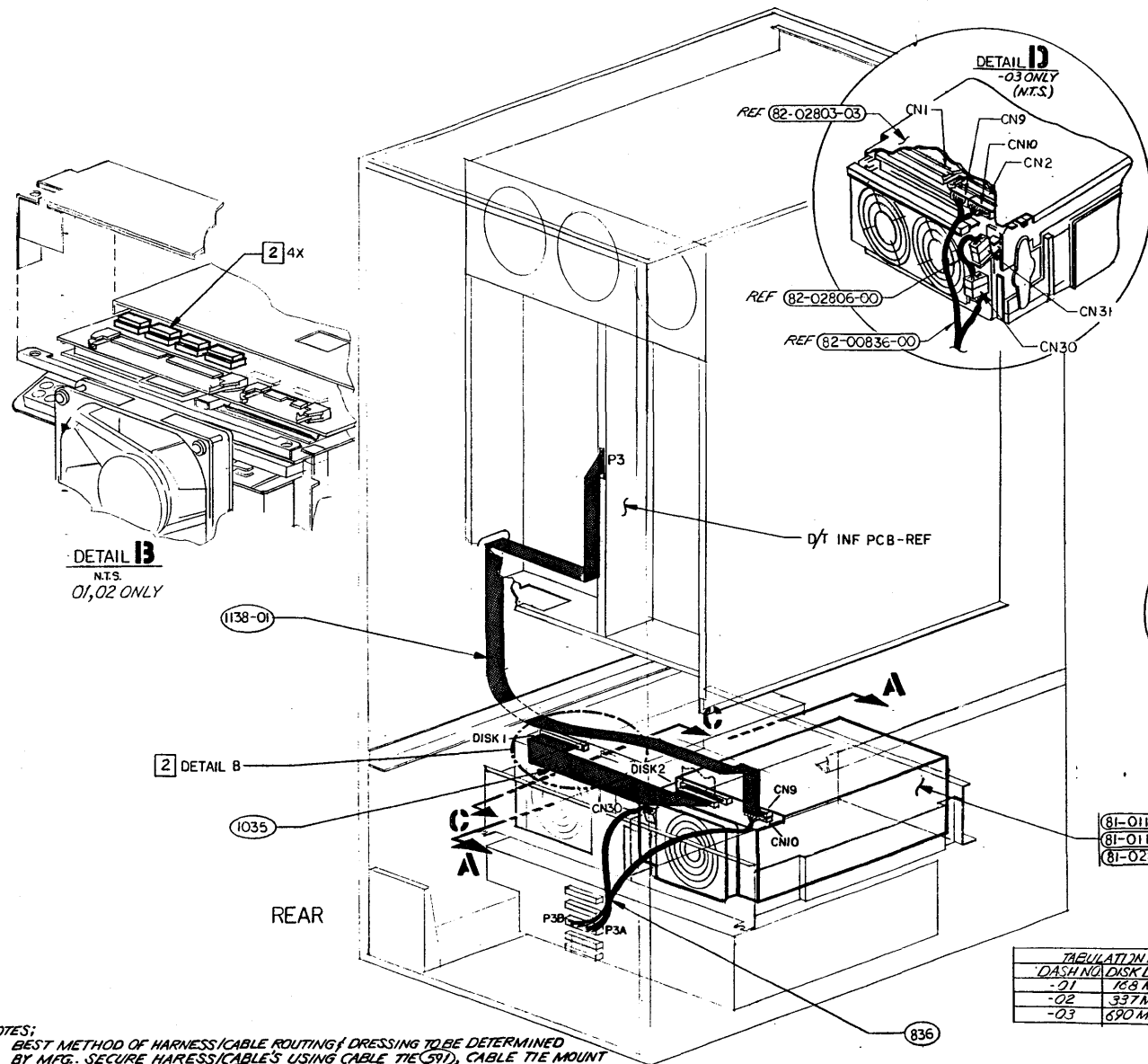

TABULATION BLOCK	DASH NO	DISK DRIVE
-01	163 MB	
-02	337 MB	
-03	690 MB	

- NOTES:
- BEST METHOD OF HARNESS/CABLE ROUTING & DRESSING TO BE DETERMINED BY MFG. SECURE HARNESS/CABLES USING CABLE TIE (59), CABLE TIE MOUNT (58) OR FLAT CABLE CLAMP (67) WHERE NEEDED.
  - REMOVE TERMINATORS (SHOWN IN DETAIL B) IN 1<sup>ST</sup> DISK DRIVE.
  - TORQUE REQUIREMENTS: SEE PS-99065.
  - ADD LOCTITE ARETE PIN 04-01137 TO INDICATED SCREW THREADS. (8 PL)
  - TORQUE TO 15±1 IN/LBS.

- SET DISK ADDRESS WITH THE THREE KEYS ON SW1 LOCATED ON TOP OF DISK DRIVE AS SHOWN.  
DISK ADDRESS | KEY 1 | KEY 2 | KEY 3 |  
                  | ON | OFF | OFF |

REV	BY	DATE	DESCRIPTION	APPRD	DATE
REVISIONS					
VENO					
KIT, DISK DRIVE, 2ND, MAXI, 166/337/690MB					
FIG NO AD-00978-XX SMT I REV H					





DATE	DESCRIPTION	BY	CHKD
A	IMP 11/14/77	WDD RELEASE PER ECO # 7184	2/28/83
B	KD 1/2/78	REVISED PER ECO # 7483	2/28/83
C	MM 3/24/78	REVISED PER ECO # 7473	11-11-83
D	LE 1/1/79	REVISED PER ECO # 7752	1-2-87
E	XP 2/11/80	REVISED PER ECO # 7900A	1-19-80
F	1/2/1989	* 32-0286-00	
G	1/2/1989	* 32-0286-00	
H	1/2/1989	INACTIVE PER ECO # 1829	1/2/91

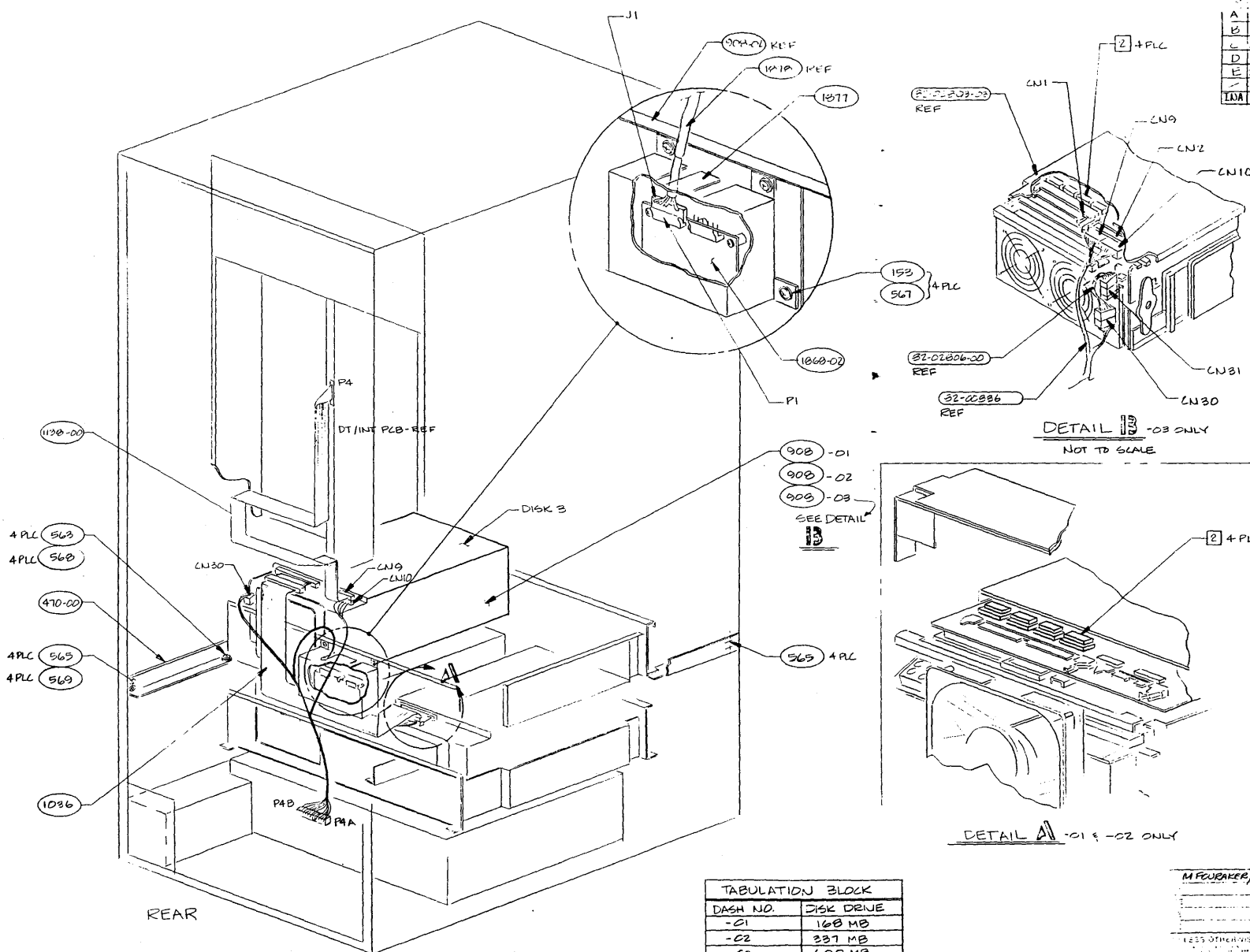

**NOTES: UNLESS OTHERWISE SPECIFIED**

1. BEST METHOD OF HARNESS/CABLE ROUTING & DRESSING TO BE DETERMINED BY MFG. SECURE HARNESS/CABLE USING CABLE (59), CABLE TIE MOUNT (59) OR FLAT CABLE CLAMP (767) WHERE NEEDED.

2. REMOVE TERMINATORS (SHOWN IN DETAIL A) IN 1ST AND 2ND DISK DRIVES.

3. SET DISK ADDRESS WITH THE THREE KEYS ON SWI LOCATED ON TOP OF DISK DRIVE AS SHOWN:

DISK ADDRESS	KEY1	KEY2	KEY3
2	OFF	ON	OFF
SWITCH 5	ON	ON	ON

TABULATION BLOCK	
DASH NO.	DISK DRIVE
-01	168 MB
-02	337 MB
-03	690 MB

MFG DATE	3/22/85
REV	
LESS OTHERWISE SPECIFIED	KIT, DISK DRIVE, 3RD,
FINISHES	MAX1, 168/337/690MB
TOLERANCE	SCALE NONE
REV	AD-01189-KX E

REAR



A	PROD REL PER ECO * 0184	14 MAR 85
B	REV PER ECO * 0241	21 MAY 85
C	REV PER ECO * 0353	20 FEB 86
D	REV PER ECO * 0483	30 JUN 86
E	REV PER ECO * 0474	11 AUG 86
F	REV PER ECO * 0752	4-2-87
H	REV PER ECO * 0787	5-15-87
TM	INACTIVE PER ECO # 1829	1/8/91 TE

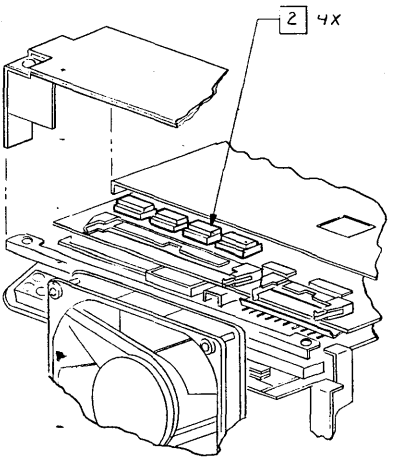
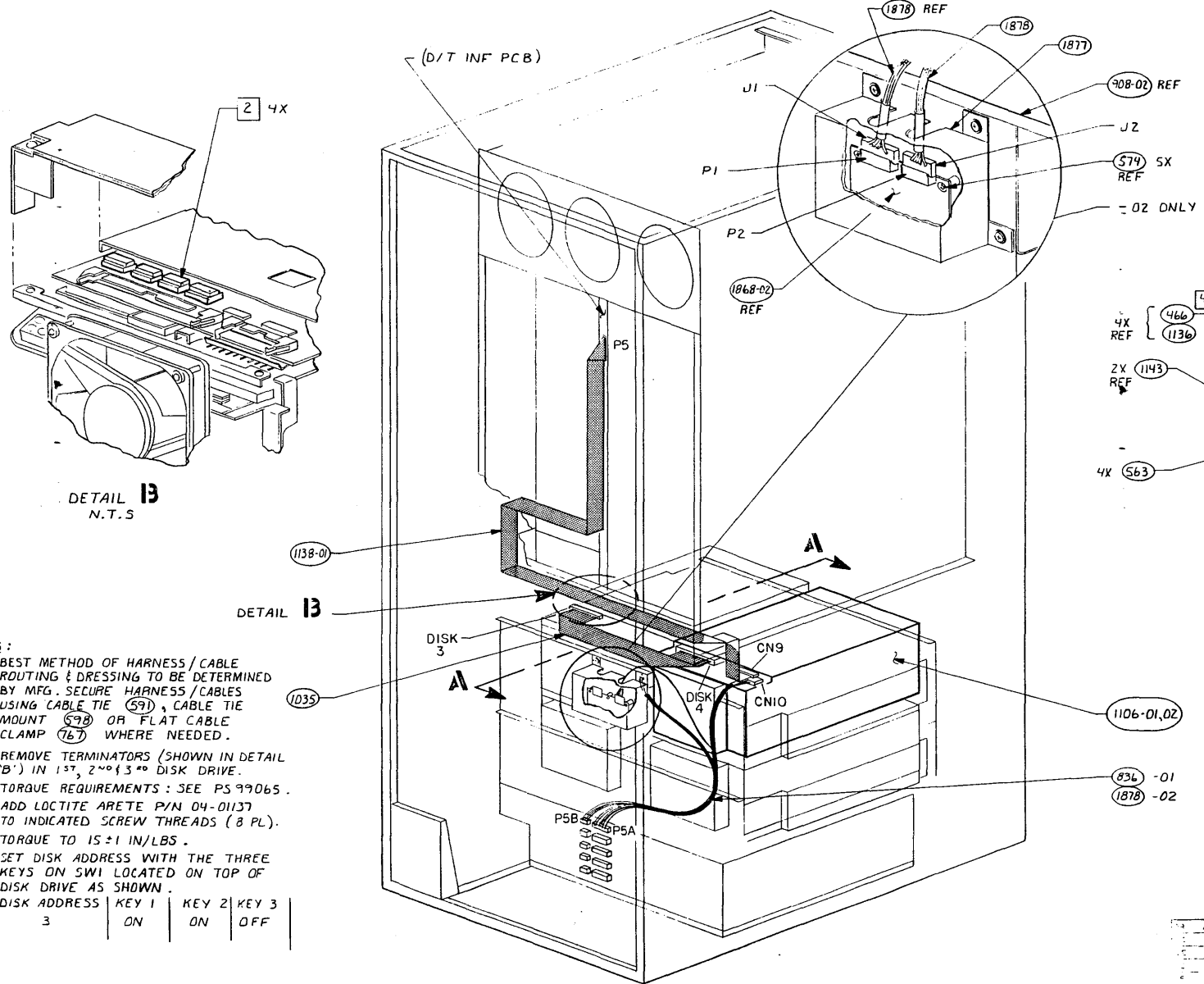

DETAIL B  
N.T.S.

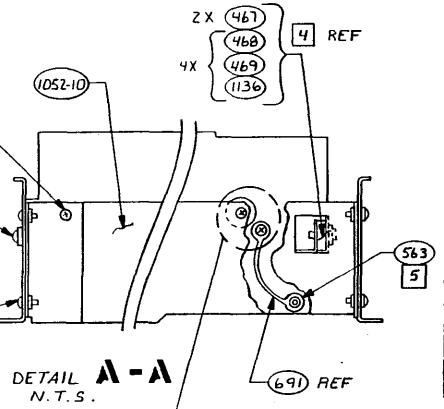

DETAIL A-A  
N.T.S.

NOTES:

- BEST METHOD OF HARNESS / CABLE ROUTING & DRESSING TO BE DETERMINED BY MFG. SECURE HARNESS / CABLES USING CABLE TIE (591), CABLE TIE MOUNT (598) OR FLAT CABLE CLAMP (767) WHERE NEEDED.
- REMOVE TERMINATORS (SHOWN IN DETAIL 'B') IN 1<sup>ST</sup>, 2<sup>ND</sup> & 3<sup>RD</sup> DISK DRIVE.
- TORQUE REQUIREMENTS: SEE PS 99065.
- ADD LOCTITE ARETE P/N 04-01137 TO INDICATED SCREW THREADS (8 PL).
- TORQUE TO 15 ± 1 IN/LBS.
- SET DISK ADDRESS WITH THE THREE KEYS ON SW1 LOCATED ON TOP OF DISK DRIVE AS SHOWN.

DISK ADDRESS	KEY 1	KEY 2	KEY 3
3	ON	ON	OFF

SUFFIX	DISK DRIVE (81-01106-XX)
-01	168 MB
-02	337 MB

APPROVED	7/9/88	DATE	7/9/88
DESIGNED BY		SCALE	1/4
KIT, DISK DRIVE, 4", MAXI		ISSUE NO.	D
		REV	AD-01141-XX H



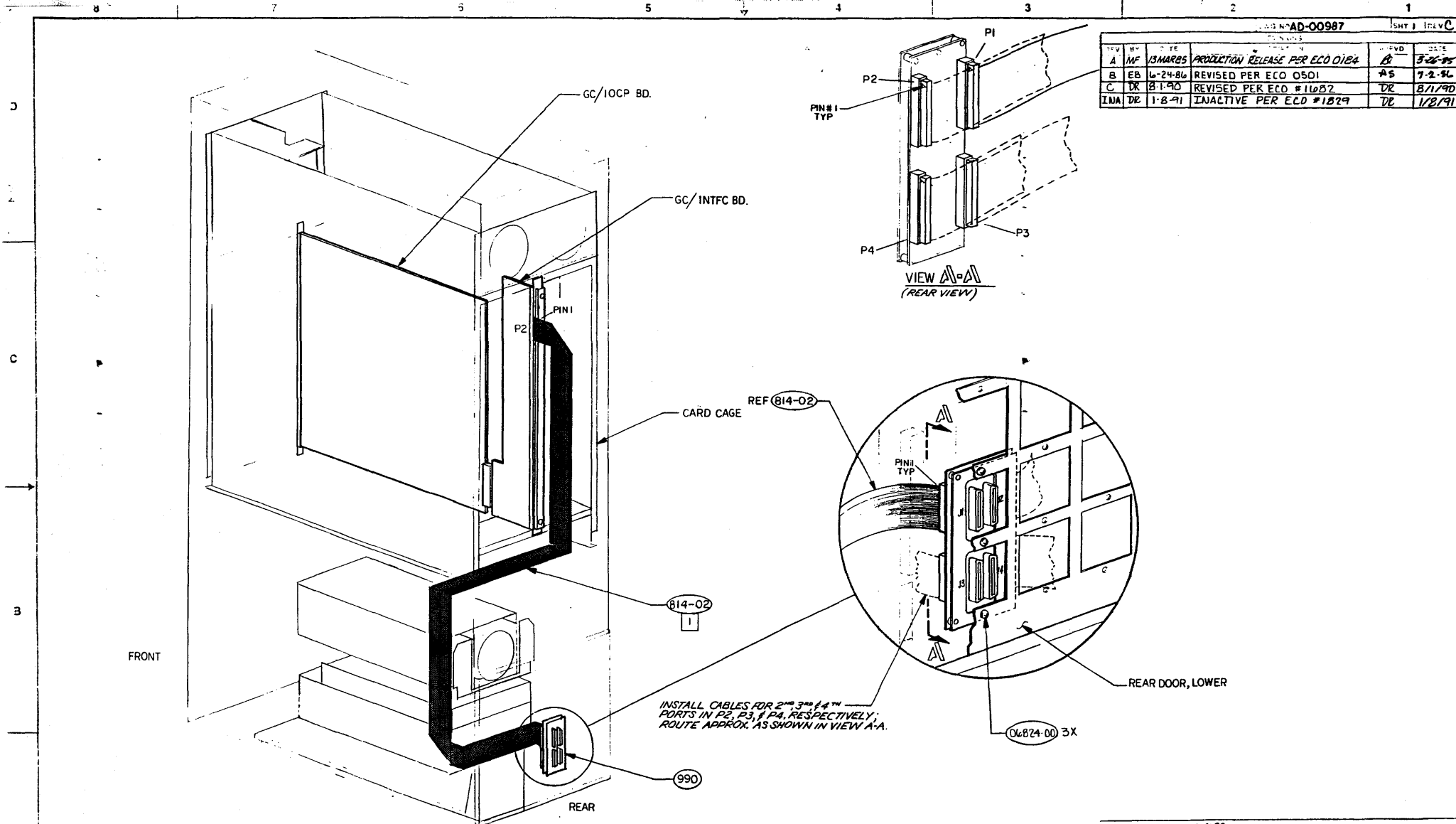

REV. NO. AD-00987

REV. NO.	DATE	DESCRIPTION	BY	DATE
A	MF 13MAR85	PRODUCTION RELEASE PER ECO 0124	AS	3-26-85
B	EB 6-24-86	REVISED PER ECO 0501	DE	7-2-86
C	DK 8-1-90	REVISED PER ECO #11082	DE	8/1/90
INA	DE 1-8-91	INACTIVE PER ECO #1829	DE	1/8/91

NOTES;  
 1. BEST METHOD OF CABLE ROUTING / DRESSING TO BE DETERMINED BY MFG.  
 SECURE CABLES USING CABLE TIE (591) CABLE TIE MOUNT (590) OR FLAT CABLE  
 CLAMP (787) WHERE NEEDED.

PHILLIPS 2-5-85

REVISIONS

UNLESS OTHERWISE SPECIFIED

MATERIALS FINISHES

KIT, GC/PARALLEL PORT

NO. NO.



REV	DATE	DESCRIPTION	BY	CHK
A	10-28-66	RELEASE PER ECO 0293	...	...
B	10-28-66	REVISED PER ECO 0293	...	...
C	2-28-66	REVISED PER ECO 0401	...	...
D	1-12-66	REVISED PER ECO 0381	...	...
E	1-12-66	REVISED PER ECO 0381	...	...

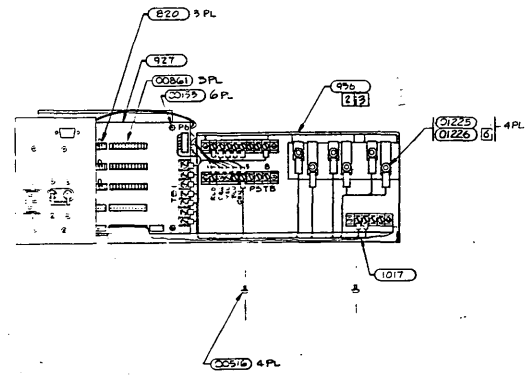
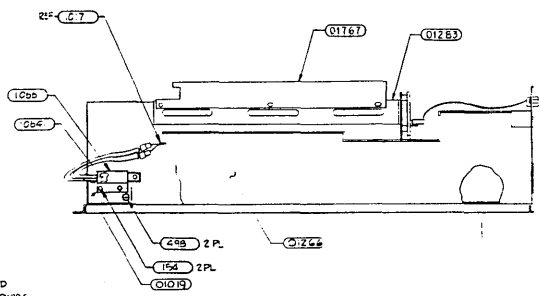
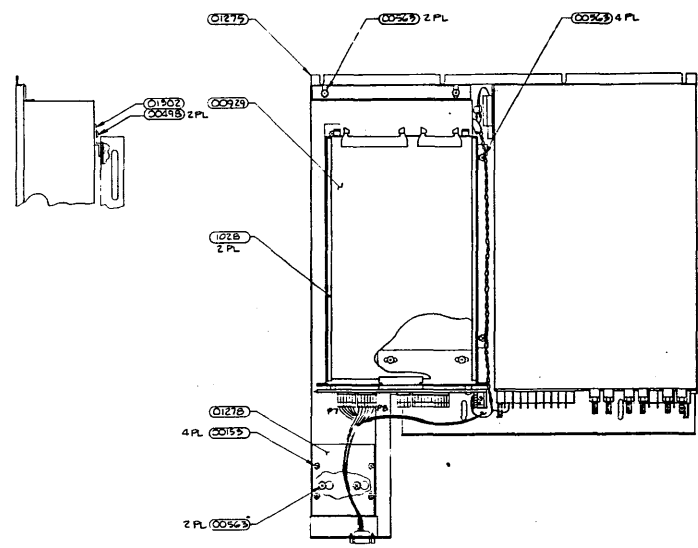

- NOTES: UNLESS OTHERWISE SPECIFIED
- REFER TO LM-01295 & WD-01295
  - REMOVE THE FOLLOWING SENSE LINES SUPPLIED W/ SWITCHING POWER PWR SUPPLY:
    - A) 25V 4-5
    - B) 5V 4-5
    - C) 12V 4-5
 WIRE AT THE SOLDER END OF SENSE LINE MAY BE REMOVED BY CUTTING IT FROM LWS; LWS CAN REMAIN.
  - REMOVE & DISCARD INPUT VOLTAGE STRAPS (GR) SUPPLIED WITH PWR SUPPLY.
  - WIRE COLORS SHOWN FOR REF ONLY.
  - DRILL NUMBERS SHOWN FOR REF ONLY & MAY NOT APPEAR ON PART BODIES.
  - TIGHTEN TO 40 O IN/LBS ± 10 IN/LBS.
  - REFER TO TORQUE REQUIREMENTS SPECIFICATION 15-99363.

REV	DATE	BY	CHK	REV	DATE	BY	CHK
<b>XERO</b>							
UNLESS OTHERWISE SPECIFIED							
MATERIALS FINISHES							
ASSEMBLY							
P/M/POWER SUPPLY, 1800W							





REV	BY	DATE	DESCRIPTION	APPVD	DATE
A	PEA	12 SEP 85	RELEASE PER ECO #293	MA	12/17/85
B	CC	10-28-85	CHANGE PER ECO 0306	MA	12/17/85
C	TS	28/FEB/86	REV ROLL PER ECO 0401	MA	3/20/86
D	EB	6-26-86	REVISED PER ECO 0511	MA	8/14/86
E	LE	9-2-86	REV ROLL PER ECO 0474	MA	01/07/86
INA	A	3-1-89	INACTIVE PER ECO #1118	MA	3-11-89

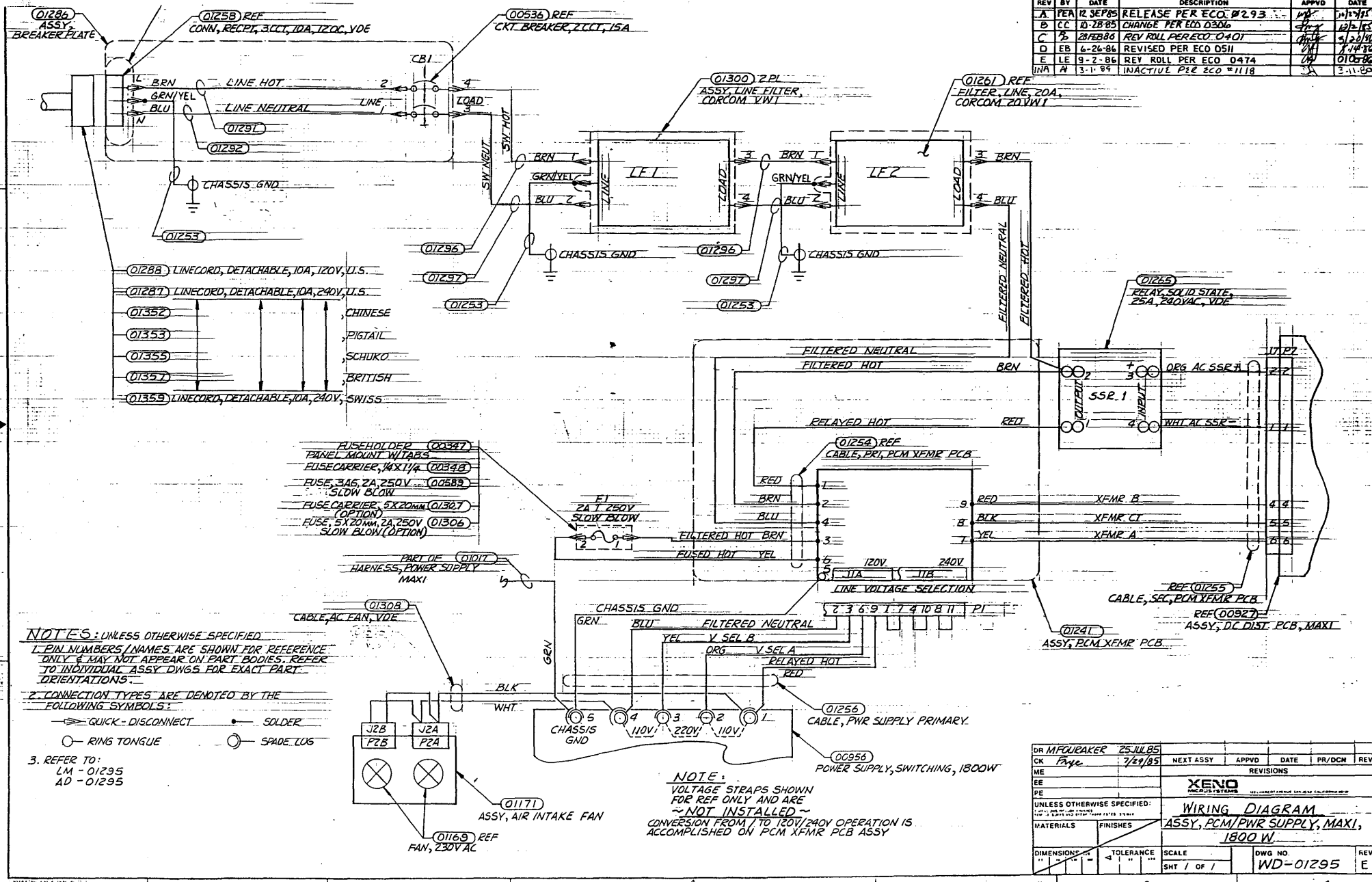

DR	DATE	DESCRIPTION	APPVD	DATE	PR/DCM	REV
DR	MFOURAKER	25 JUL 85				
CK	Page	7/27/85				
ME						
EE						
PE						
UNLESS OTHERWISE SPECIFIED:						
MATERIALS FINISHES						
DIMENSIONS TOLERANCE SCALE DWG NO. REV						
SHT / OF 1 WD-01295 E						



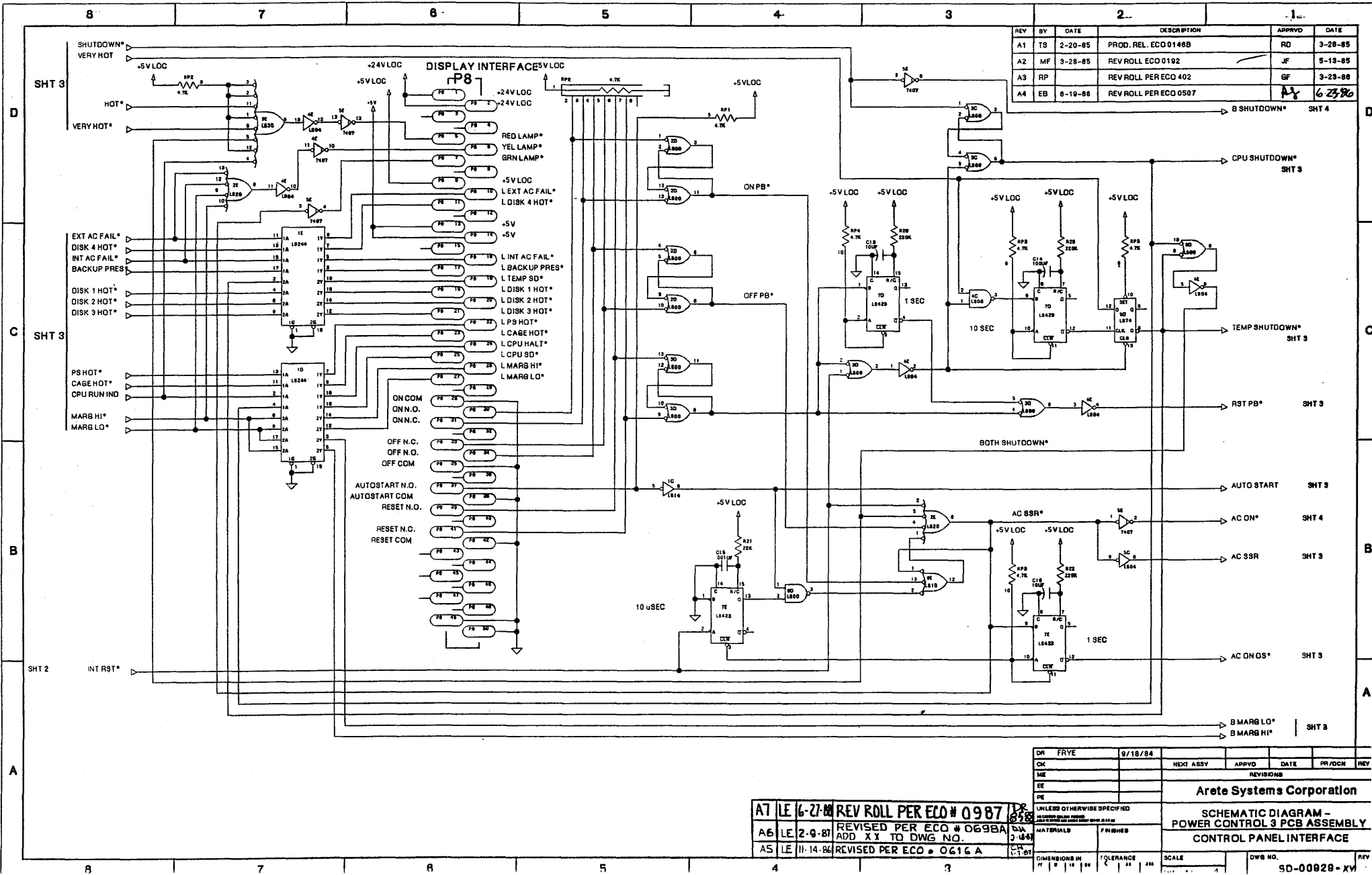

A7 LE 16-27-86 REV ROLL PER ECO # 0987  
 A6 LE 2-9-87 REVISED PER ECO # 0698A  
 A5 LE 11-14-86 REVISED PER ECO # 0616A

SCHMATIC DIAGRAM -  
 POWER CONTROL 3 PCB ASSEMBLY  
 CONTROL PANEL INTERFACE



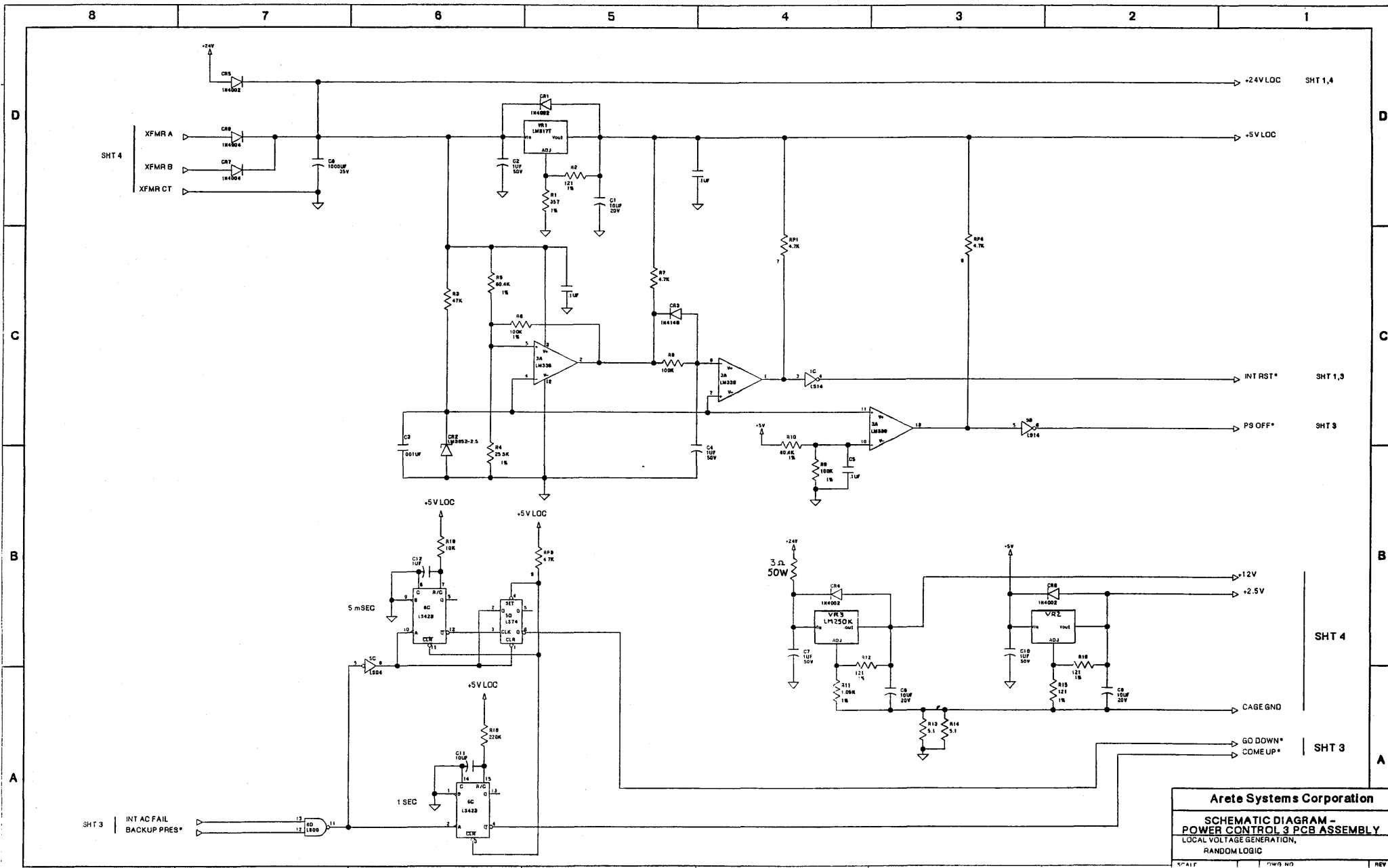

Arete Systems Corporation  
 SCHEMATIC DIAGRAM -  
 POWER CONTROL 3 PCB ASSEMBLY  
 LOCAL VOLTAGE GENERATION,  
 RANDOM LOGIC



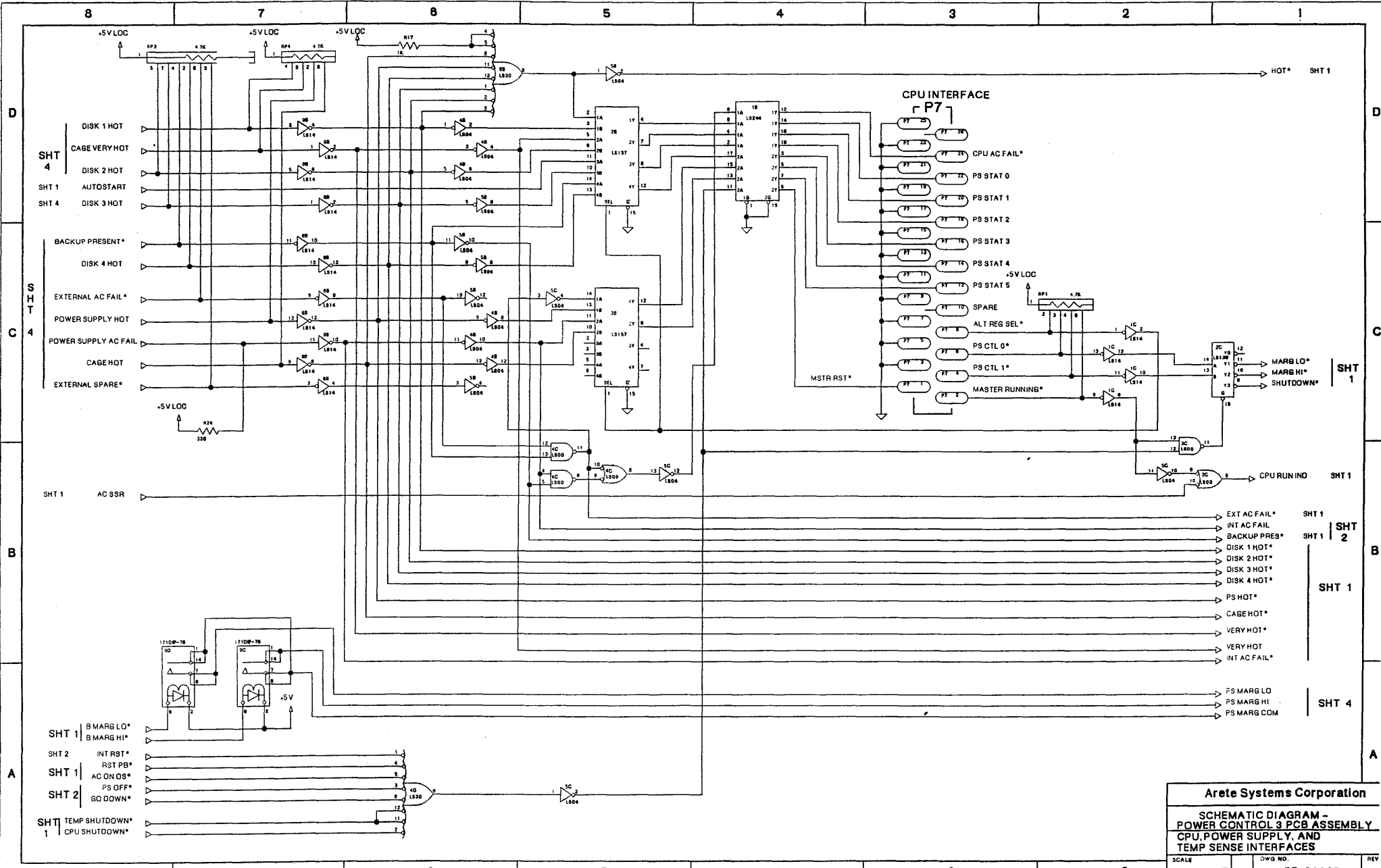





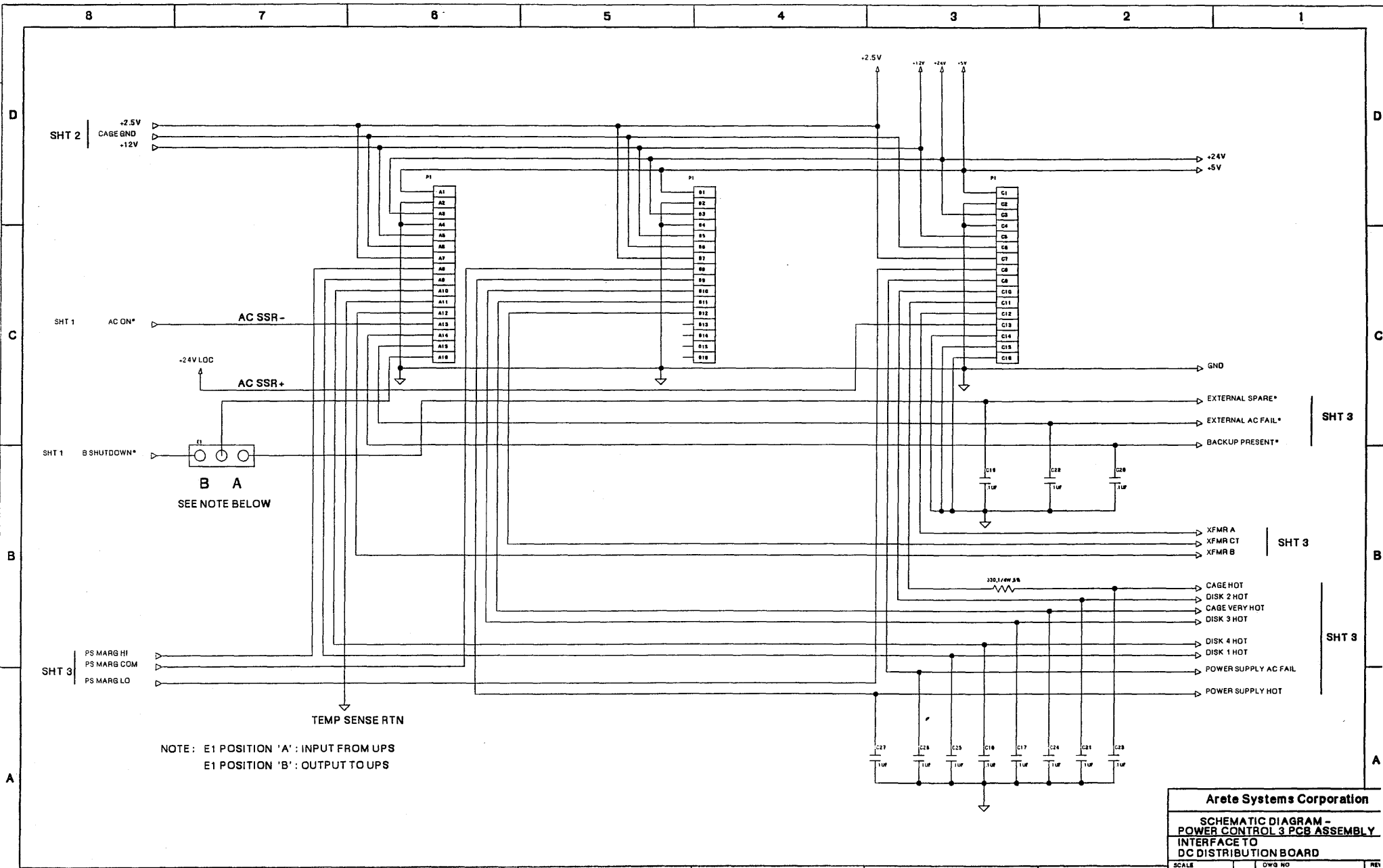

NOTE: E1 POSITION 'A': INPUT FROM UPS  
 E1 POSITION 'B': OUTPUT TO UPS

<b>Arete Systems Corporation</b>	
<b>SCHEMATIC DIAGRAM - POWER CONTROL 3 PCB ASSEMBLY INTERFACE TO DC DISTRIBUTION BOARD</b>	
SCALE	DWG NO
1/16" = 1"	SD-00828-XX

REV A



PCB DISPLAY SH1 TOP 1

A3 LE 3-9-87 REVISED DWG # ELO #0692 24 21281 SD-00992-XX A3

REV	BY	DATE	DESCRIPTION	APPV
A	TS	1-7-85	PROD. REL. PER ECO #0141	
A1	LE	1-14-87	REV ROLL PER ECO #0684	DA
A2	LE	1-19-87	REV ROLL PER ECO #0704	DA

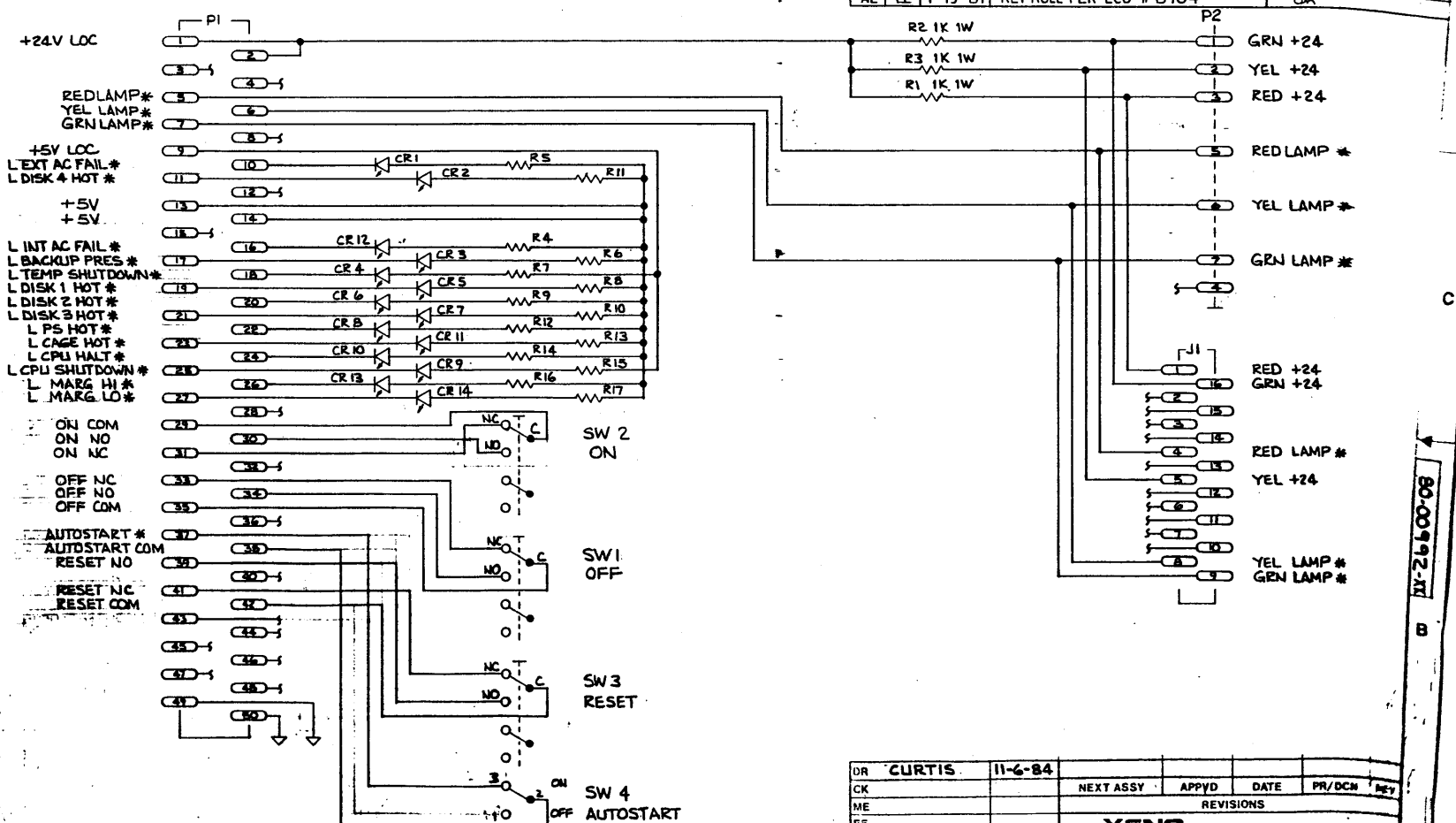

**NOTES**  
 1. R4-17 ARE 270Ω, 1/4W, 5%  
 2. CR2, 4-11: MIMP-1300 (RED)  
 3. CR1, 12-14: MIMP-1400 (YEL)  
 4. CR3, MIMP-1503 (GRN)  
 5. CATHODE GOES TO SQUARE PAD.

DR	CURTIS	11-6-84				
CK			NEXT ASSY	APPYD	DATE	PR/DCN
ME			REVISIONS			
EE			<b>XENO</b> MICROSYSTEMS 180 CHARCOT AVENUE SAN JOSE CALIFORNIA 95128			
PE						
UNLESS OTHERWISE SPECIFIED:						
MATERIALS			FINISHES			
DIMENSIONS IN			TOLERANCE		SCALE	
SHT			OF		C	
DWG NO.			SD-00992-XX			

NY-26600-08



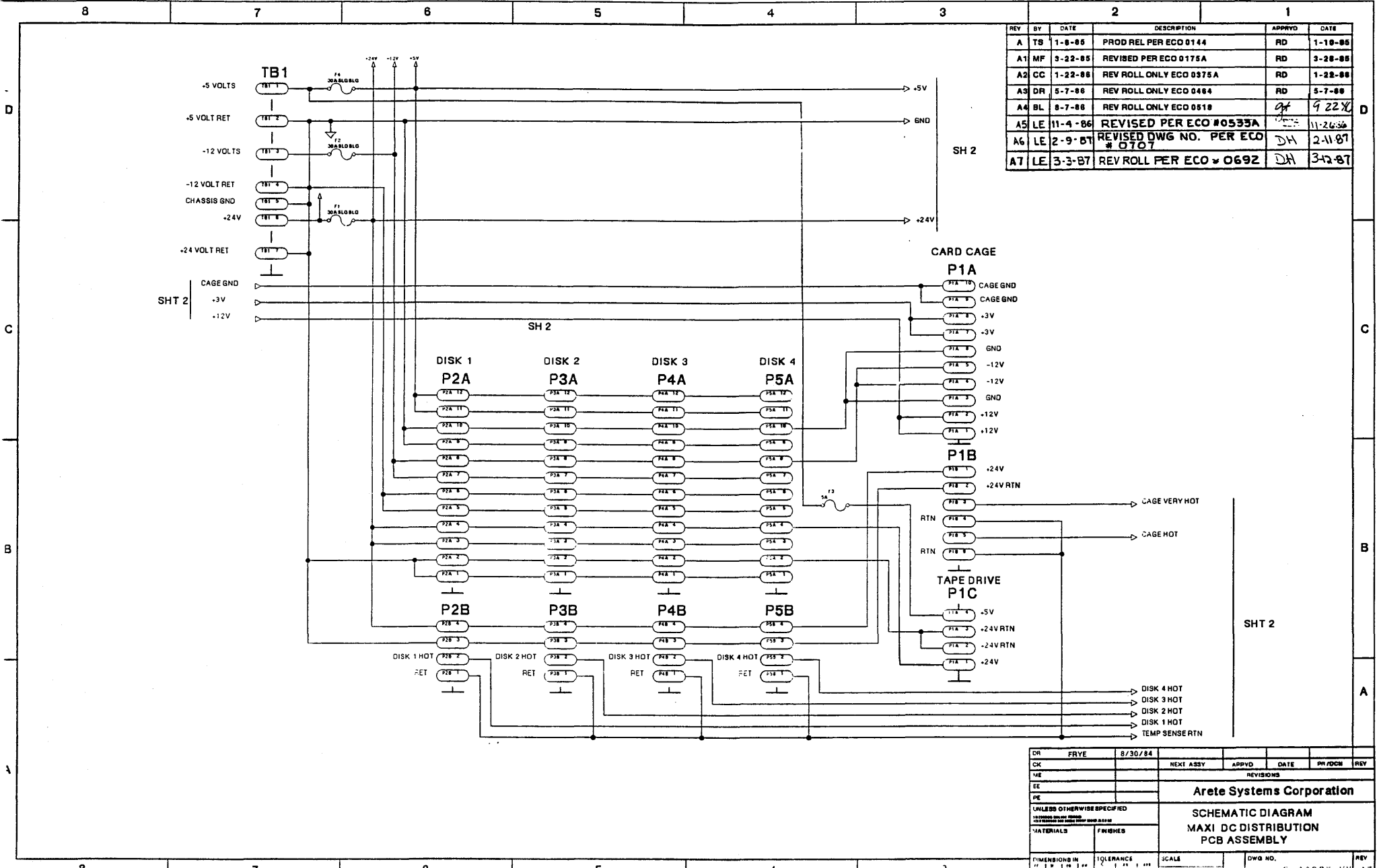

REV	BY	DATE	DESCRIPTION	APPRVD	DATE
A	TS	1-8-85	PROD REL PER ECO 0144	RD	1-18-85
A1	MF	3-22-85	REVISED PER ECO 0175A	RD	3-28-85
A2	CC	1-22-86	REV ROLL ONLY ECO 0375A	RD	1-22-86
A3	DR	5-7-86	REV ROLL ONLY ECO 0484	RD	5-7-86
A4	BL	8-7-86	REV ROLL ONLY ECO 0518	RD	9-22-86
A5	LE	11-4-86	REVISED PER ECO #0595A	RD	11-26-86
A6	LE	2-9-87	REVISED DWG NO. PER ECO # 0707	RD	2-11-87
A7	LE	3-3-87	REV ROLL PER ECO # 0692	RD	3-2-87

CR	FRVE	8/30/84	NEXT ASSY	APPRVD	DATE	PR/DCM	REV
CK							
ME							
EE							
PE							
Arete Systems Corporation							
SCHEMATIC DIAGRAM MAXI DC DISTRIBUTION PCB ASSEMBLY							
UNLESS OTHERWISE SPECIFIED							
DIMENSIONS IN INCHES UNLESS OTHERWISE SPECIFIED							
MATERIALS FINISHES							
DIMENSIONS IN TOLERANCE SCALE DWG NO. REV							



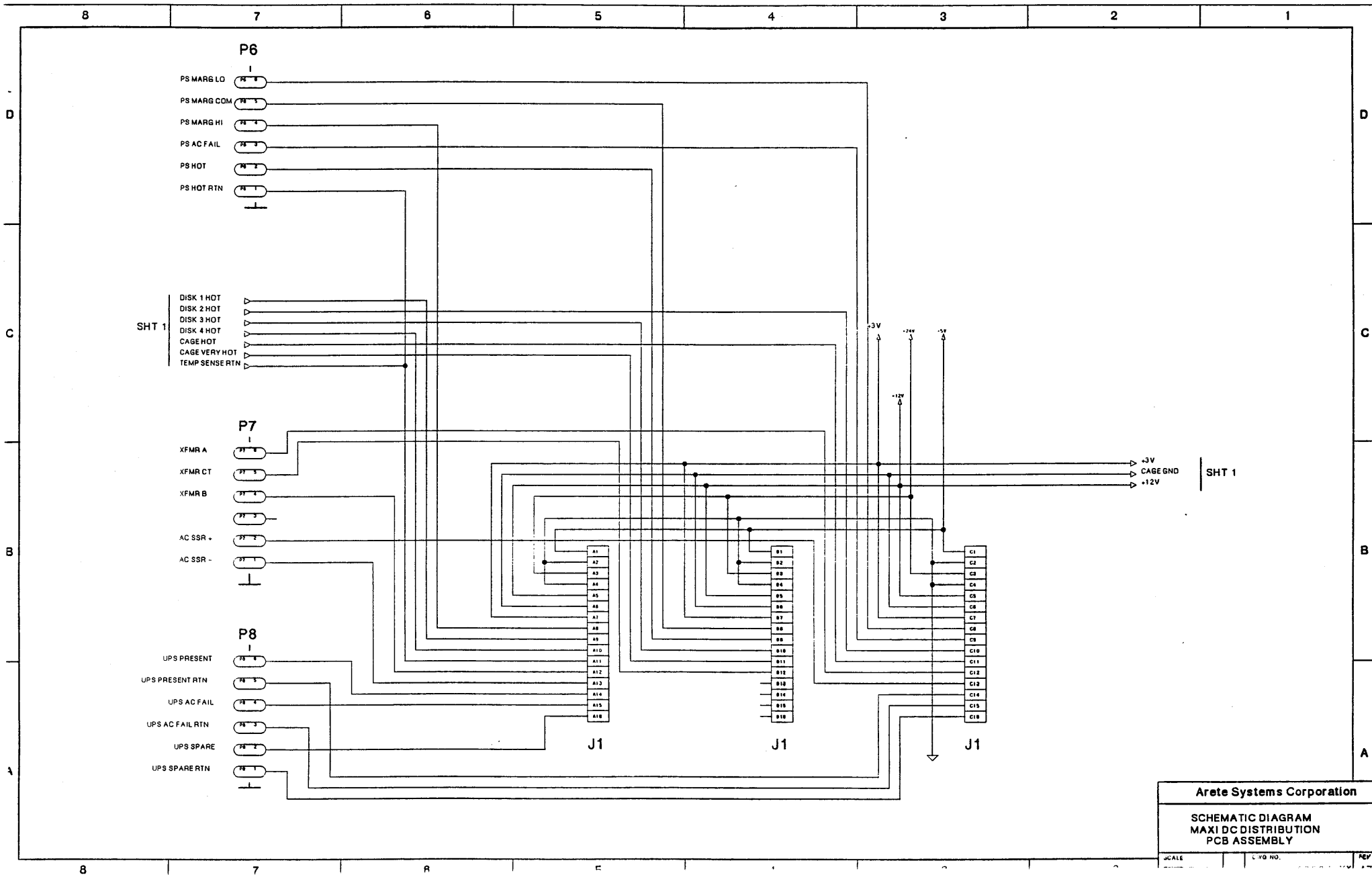

Arete Systems Corporation  
 SCHEMATIC DIAGRAM  
 MAXI DC DISTRIBUTION  
 PCB ASSEMBLY

SCALE: C.VO NO. REV





REV	BY	DATE	DESCRIPTION	APPROV	DATE
A	CE	1-18-78	REVISED PER EGO #0403	CEP	2-22-78
B	AP	4-7-80	REVISED PER EGO #0474	AP	4-22-80
C	LE	10-18-84	REVISED PER EGO #0510	LE	11-2-84
D	LE	12-18-84	REVISED PER EGO #0592	LE	11-2-84
L	LE	11-24-86	REVISED PER EGO #0494	LE	11-2-86

4. DRIVE FORMATTER PCB - EACH DRIVE MUST HAVE ITS LATCH ADDRESS SET TO DIMENSIONS 37, 321 3/8" AT LOCATION U3W.

ADDRESS	37	321 3/8"
0	C	C
1	C	C
2	C	C
3	C	C

EXAMPLE: IF PERIPHERAL IS FIRST IN LINE, ADDRESS IS '0'. IF PERIPHERAL IS SECOND IN LINE, ADDRESS IS '1' ETC.

5. IF LATCH BRACKET AND DRIVE LATCH ARE NOT FULLY ENGAGED, BEND LATCH BRACKET TOWARD DRIVE LATCH UNTIL PROPERLY ENGAGED.

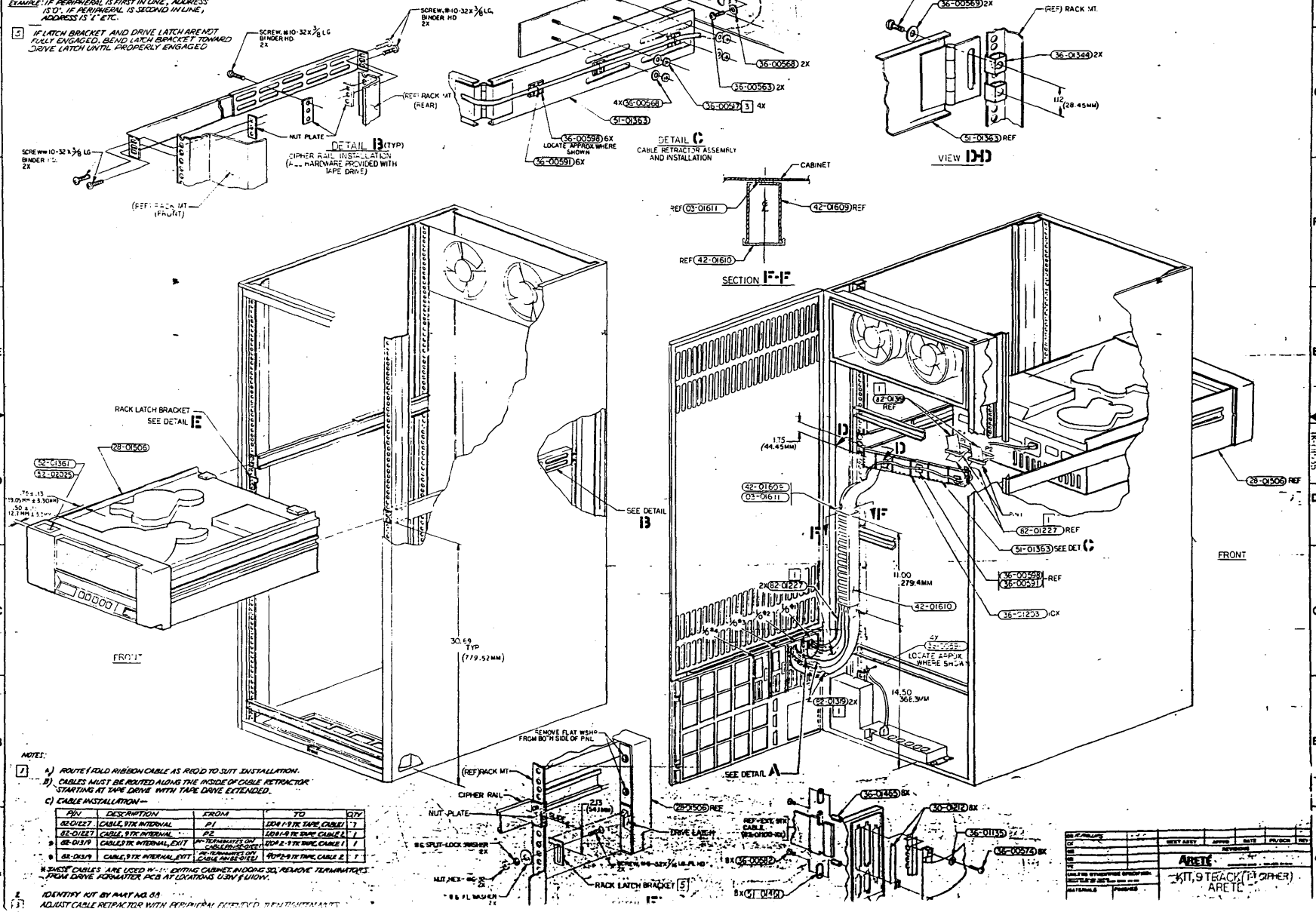

NOTES:

- 1. ROUTE FOLD RIBBON CABLE AS SHOWN TO SUIT INSTALLATION.
- 2. CABLES MUST BE ROUTED ALONG THE INSIDE OF CABLE RETRACTOR STARTING AT TAPE DRIVE WITH TAPE DRIVE EXTENDED.

C) CABLE INSTALLATION -

PN#	DESCRIPTION	FROM	TO	QTY
35-01521	CABLE, 1/8" INTERNAL	#1	DRIVE 1/8" TAPE CABLE 1	1
35-01521	CABLE, 1/8" INTERNAL	#2	DRIVE 1/8" TAPE CABLE 1	1
35-01517	CABLE, 1/8" INTERNAL, EXT	2X TERMINATES ON CIPHER RAIL	DRIVE 1/8" TAPE CABLE 1	1
35-01517	CABLE, 1/8" INTERNAL, EXT	2X TERMINATES ON CIPHER RAIL	DRIVE 1/8" TAPE CABLE 2	1

\* EXISTING CABLES ARE USED IN EXISTING CABINETS AND DRIVES. REMOVE TERMINATORS FROM DRIVE FORMATTER PCB AT LOCATIONS U3W & U3W1.

IDENTIFY KIT BY PART NO. 88. ADJUST CABLE RETRACTOR WITH PERIPHERAL EXTENDED. THEN DISMOUNT KIT.

REV	BY	DATE	DESCRIPTION	APPROV	DATE
<p>ARETE</p> <p>KIT, 9 TRACK (1/8" CIPHER)</p> <p>ARETE</p>					



REV	BY	DATE	DESCRIPTION	APP'D	DATE
A	12	7-27-74	REVISED PER ECO #1103		7/27/74
B	1	9-26-74	REVISED PER ECO #1105		9/26/74
C	1	12-11-74	REVISED PER ECO #1105		12/11/74
D	1	1-11-75	REVISED PER ECO #1105		1/11/75
E	1	4-18-75	REVISED PER ECO #1105		4/18/75
F	1	4-18-75	REVISED PER ECO #1105		4/18/75
G	1	4-18-75	REVISED PER ECO #1105		4/18/75
H	1	4-18-75	REVISED PER ECO #1105		4/18/75

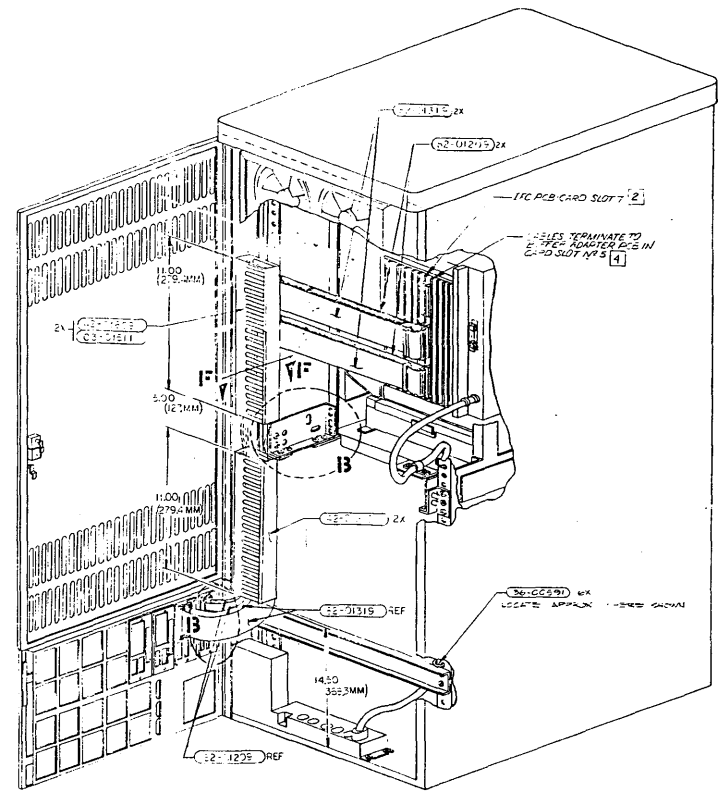
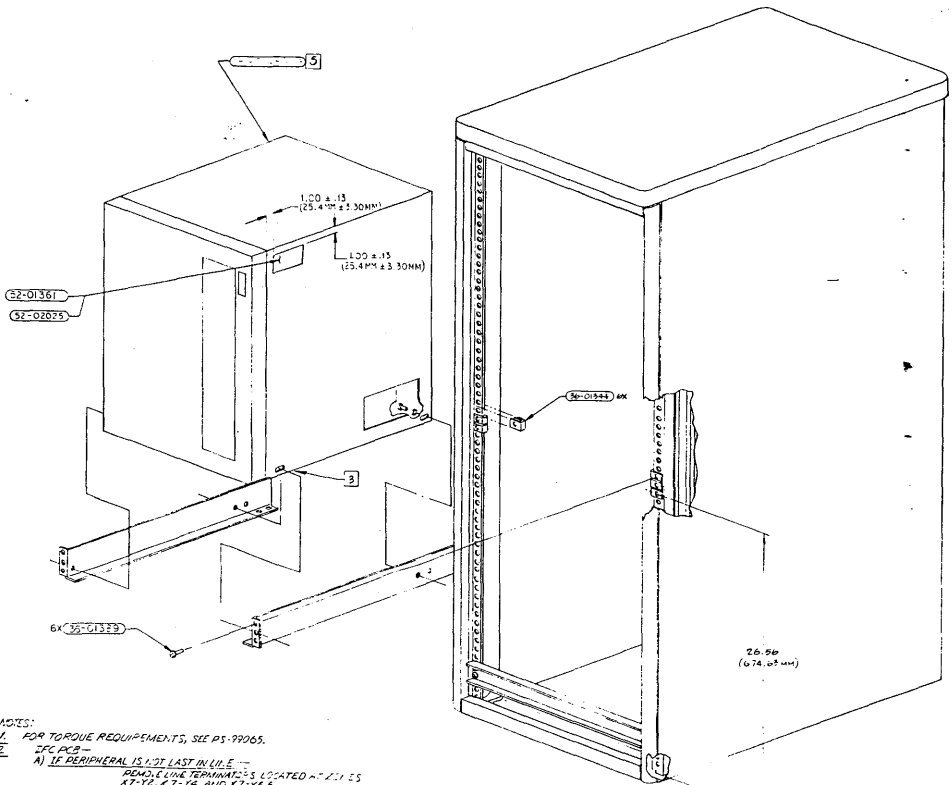

NOTES:  
 1. FOR TORQUE REQUIREMENTS, SEE PS-79065.  
 2. ITC PCB

A) IF PERIPHERAL IS LAST IN LINE -  
 READ LINE TERMINATOR'S LOCATED AT X1-15  
 X7-12, X7-14 AND X7-V5.5  
 B) SET MPU ADDRESS SWITCH CIRCUIT CONNECTIONS PER THE FOLLOWING TABLE.

MPU ADDRESS	SWITCH POSITION	SWITCH CIRCUIT
0	0-06	06-05 03-02
1	0-06	06-05 03-02
2	0-09	06-07 03-04
3	0-09	05-07 03-04

EXAMPLE: IF PERIPHERAL IS FIRST IN LINE, MPU ADDRESS IS "0"  
 IF PERIPHERAL IS SECOND IN LINE, MPU ADDRESS IS "1"; ETC.  
 C) AT I/C LOCATION X7-11 - 1) SW 12-13 - PERIODIC TIMER  
 2) SW 14-15 - ADD-ON ALER  
 OPEN SERVICE SW 16 TO GAIN ACCESS TO FRONT K-10 SCHEMATIC  
 BUFFER ADAPTER KIT - A-115 REQUIRED - SEE KIT INSTRUCTIONS  
 ACTIVE LINE TERMINATOR LOCATED AT 20K X1-Y4.5, X7-16(X7-V7.5)

THE RUI-1454AC INTERFACE CHARACTERISTICS HAVE BEEN PROGRAMMED BY A SET OF PARAMETERS WHICH ARE STORED IN MEMORY. IN MEMORY ADDRESS 0, THE VALUES OF THESE PARAMETERS ARE AS FOLLOWS:  
 1) 01-05: DEVICE TYPE: LUN (SHELL) FIXED TO C/C COMPATIBLE MODE  
 2) 02-05: DATA TRANSFER RATE: 0.5 (KB/S)  
 3) 03-05: HEAD LEAD RETRY TIMES: 0 (SEC)  
 4) 04-05: HEAD RETRY TIMES: 0 (SEC)  
 5) 05-05: HEAD RETRY TIMES: 0 (SEC)  
 6) 06-05: BUFFER OVERWRITE MODE (LOGICAL EOT MODE): STOP DATA TRANSFER & WAIT FOR AVAILABLE LOGICAL EOT SUPPORT MODE

7) 05-01: BUFFER SYNCHRONIZE: 0: INWRITE: DOUBLE TAKE MARK COMMAND  
 1: WRITE SYNC COMMAND  
 2: DIRECTION CHANGE COMMAND  
 3: HEAD: DOUBLE TAKE MARK, EOT OR EOT  
 4: DIRECTION CHANGE COMMAND  
 8) 1-1: ON SEND STOP LINE IN WRITE COMMAND: STrobe (ILLUDED WITH WHITE STROBE)  
 9) 1-2: ON WRITE BUS INITIATE: 1: ALL (ILLUDED WITH WHITE STROBE)

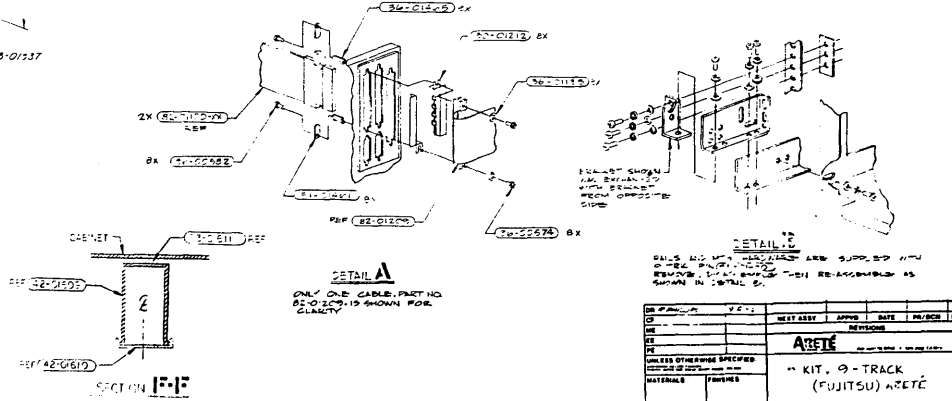

FOR PARTS INFORMATION  
 CONTACT FUJITSU  
 FUJITSU SYSTEMS (AMERICA) INC.  
 1000 SHOREVIEW DRIVE  
 RICHMOND, CALIF. 94681

FOR PARTS INFORMATION  
 CONTACT FUJITSU  
 FUJITSU SYSTEMS (AMERICA) INC.  
 1000 SHOREVIEW DRIVE  
 RICHMOND, CALIF. 94681

REV	BY	DATE	DESCRIPTION	APP'D	DATE
A	1	7-27-74	REVISED PER ECO #1103		7/27/74

ALL OTHERS SPECIFIED  
 MATERIALS FINISHED  
 KIT - 9 - TRACK  
 (FUJITSU) ACCTE



A	DR	1-12-87	PROD. RELEASE PER ECO 0579	3/17	1-12-87
B	DR	25 AUG 86	REV ROLL ONLY PER ECO 0559	3/17	1-12-86
C	LE	1-27-87	PROD. REL/REVISED DWS NO. PER ECO 0581	3/17	1-27-87
D	DR	14-28-87	REV ROLL PER ECO 0711	3/17	14-28-87
INA	CM	8-3-87	INACTIVE PER ECO 0799A	3/17	8-3-87

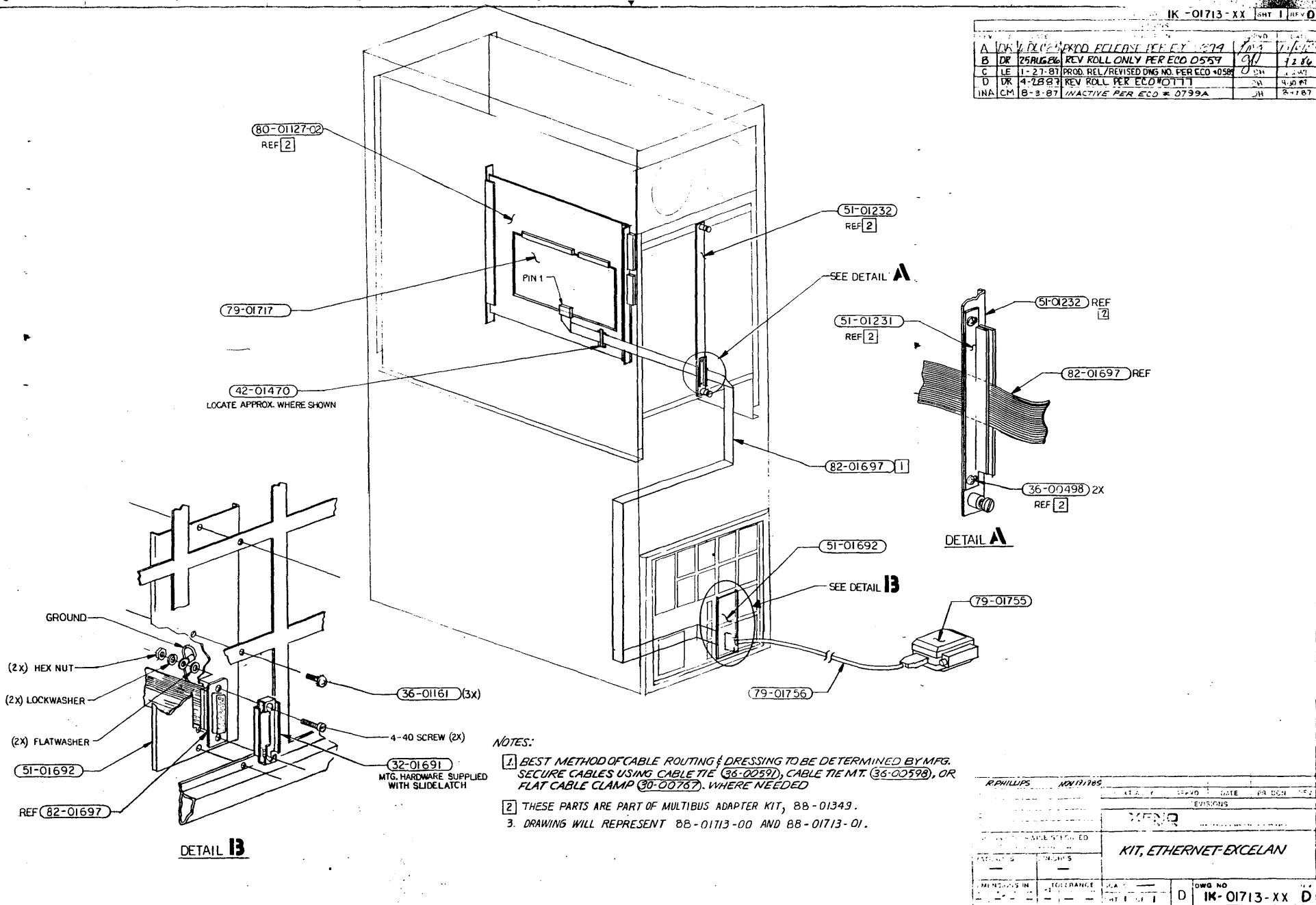

NOTES:

1. BEST METHOD OF CABLE ROUTING & DRESSING TO BE DETERMINED BY MFG. SECURE CABLES USING CABLE TIE (36-00597), CABLE TIE MT. (36-00598), OR FLAT CABLE CLAMP (30-00767), WHERE NEEDED
2. THESE PARTS ARE PART OF MULTIBUS ADAPTER KIT, 88-01349.
3. DRAWING WILL REPRESENT 88-01713-00 AND 88-01713-01.

RPHILLIPS		NOV 17 1985	
DATE	ISSUED	DATE	REV
XEROX			
KIT, ETHERNET-EXCELAN			
MINIMUMS IN	TOLERANCE	SCALE	DWG NO
			IK-01713-XX D













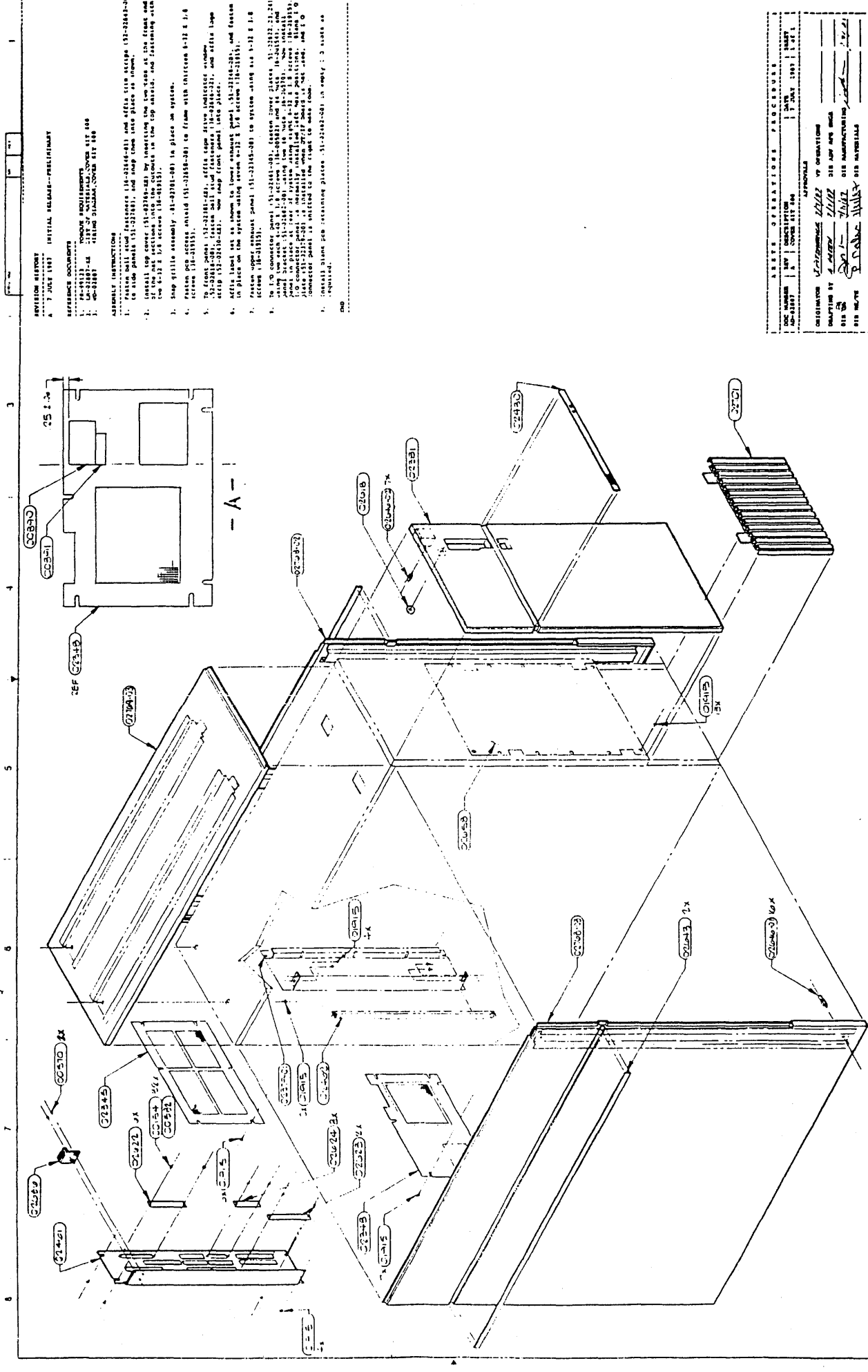

REVISION HISTORY  
 1. 7 JUL 1957 INITIAL RELEASE--PRELIMINARY

REFERENCE DOCUMENTS  
 1. 16-48113 TORQUE REQUIREMENTS  
 2. 16-48114-02 TORQUE REQUIREMENTS FOR TORQUE  
 3. 16-48114-01 TORQUE REQUIREMENTS FOR TORQUE

ASSEMBLY INSTRUCTIONS  
 1. Position all stud fasteners (16-2184-01) and affix side screws (16-2184-02) to side panels (16-2184-03), and snap them into place as shown.

2. Install top cover (16-2184-04) by inserting the top cover at the front and rear of the panel. Insert the top cover in the top inside, and fastening with the 1/4 x 1/8 screws (16-48113).

3. Snap grille assembly (16-2184-05) in place on system.

4. Remove (16-2184-06) shield (16-2184-07) to frame with wrenches 1/16 x 1/8 & 1/8.

5. To front panel (16-2184-08), affix snap drive indicator window (16-2184-09), front panel stud fasteners (16-2184-10), and affix large screw (16-2184-11). Snap front panel into place.

6. Affix label set as shown to lower edge of front panel (16-2184-08) and fasten in place on the system using 1/4 x 1/8 screws (16-48113) and fasteners (16-2184-12).

7. Remove front panel (16-2184-08) to system using the 1/16 x 1/8 & 1/8 screws (16-48113).

8. To top connector panel (16-2184-13), fasten lower plates (16-2184-14, 15) using two each 1/4 x 1/8 screws (16-48113) and 1/4 x 1/8 screws (16-48114). Snap panel in place at rear of system using 1/4 x 1/8 screws (16-48113).

9. To top connector panel (16-2184-13), install 1/4 x 1/8 screws (16-48113) and connector panel is attached to the front of case cover (16-2184-16) and 1/4 x 1/8 screws (16-48113).

10. Install blank sub-receiving plate (16-2184-17) in empty 3 slots as required.

END

ASSEMBLY OPERATIONS PROCEDURE		APPROVALS	
DOC NUMBER	REV	DATE	INITIALS
16-48113	1	7 JUL 1957	WJL
16-48114	1	7 JUL 1957	WJL
16-48115	1	7 JUL 1957	WJL
16-48116	1	7 JUL 1957	WJL
16-48117	1	7 JUL 1957	WJL
16-48118	1	7 JUL 1957	WJL
16-48119	1	7 JUL 1957	WJL
16-48120	1	7 JUL 1957	WJL
16-48121	1	7 JUL 1957	WJL
16-48122	1	7 JUL 1957	WJL
16-48123	1	7 JUL 1957	WJL
16-48124	1	7 JUL 1957	WJL
16-48125	1	7 JUL 1957	WJL
16-48126	1	7 JUL 1957	WJL
16-48127	1	7 JUL 1957	WJL
16-48128	1	7 JUL 1957	WJL
16-48129	1	7 JUL 1957	WJL
16-48130	1	7 JUL 1957	WJL
16-48131	1	7 JUL 1957	WJL
16-48132	1	7 JUL 1957	WJL
16-48133	1	7 JUL 1957	WJL
16-48134	1	7 JUL 1957	WJL
16-48135	1	7 JUL 1957	WJL
16-48136	1	7 JUL 1957	WJL
16-48137	1	7 JUL 1957	WJL
16-48138	1	7 JUL 1957	WJL
16-48139	1	7 JUL 1957	WJL
16-48140	1	7 JUL 1957	WJL
16-48141	1	7 JUL 1957	WJL
16-48142	1	7 JUL 1957	WJL
16-48143	1	7 JUL 1957	WJL
16-48144	1	7 JUL 1957	WJL
16-48145	1	7 JUL 1957	WJL
16-48146	1	7 JUL 1957	WJL
16-48147	1	7 JUL 1957	WJL
16-48148	1	7 JUL 1957	WJL
16-48149	1	7 JUL 1957	WJL
16-48150	1	7 JUL 1957	WJL
16-48151	1	7 JUL 1957	WJL
16-48152	1	7 JUL 1957	WJL
16-48153	1	7 JUL 1957	WJL
16-48154	1	7 JUL 1957	WJL
16-48155	1	7 JUL 1957	WJL
16-48156	1	7 JUL 1957	WJL
16-48157	1	7 JUL 1957	WJL
16-48158	1	7 JUL 1957	WJL
16-48159	1	7 JUL 1957	WJL
16-48160	1	7 JUL 1957	WJL
16-48161	1	7 JUL 1957	WJL
16-48162	1	7 JUL 1957	WJL
16-48163	1	7 JUL 1957	WJL
16-48164	1	7 JUL 1957	WJL
16-48165	1	7 JUL 1957	WJL
16-48166	1	7 JUL 1957	WJL
16-48167	1	7 JUL 1957	WJL
16-48168	1	7 JUL 1957	WJL
16-48169	1	7 JUL 1957	WJL
16-48170	1	7 JUL 1957	WJL
16-48171	1	7 JUL 1957	WJL
16-48172	1	7 JUL 1957	WJL
16-48173	1	7 JUL 1957	WJL
16-48174	1	7 JUL 1957	WJL
16-48175	1	7 JUL 1957	WJL
16-48176	1	7 JUL 1957	WJL
16-48177	1	7 JUL 1957	WJL
16-48178	1	7 JUL 1957	WJL
16-48179	1	7 JUL 1957	WJL
16-48180	1	7 JUL 1957	WJL
16-48181	1	7 JUL 1957	WJL
16-48182	1	7 JUL 1957	WJL
16-48183	1	7 JUL 1957	WJL
16-48184	1	7 JUL 1957	WJL
16-48185	1	7 JUL 1957	WJL
16-48186	1	7 JUL 1957	WJL
16-48187	1	7 JUL 1957	WJL
16-48188	1	7 JUL 1957	WJL
16-48189	1	7 JUL 1957	WJL
16-48190	1	7 JUL 1957	WJL
16-48191	1	7 JUL 1957	WJL
16-48192	1	7 JUL 1957	WJL
16-48193	1	7 JUL 1957	WJL
16-48194	1	7 JUL 1957	WJL
16-48195	1	7 JUL 1957	WJL
16-48196	1	7 JUL 1957	WJL
16-48197	1	7 JUL 1957	WJL
16-48198	1	7 JUL 1957	WJL
16-48199	1	7 JUL 1957	WJL
16-48200	1	7 JUL 1957	WJL







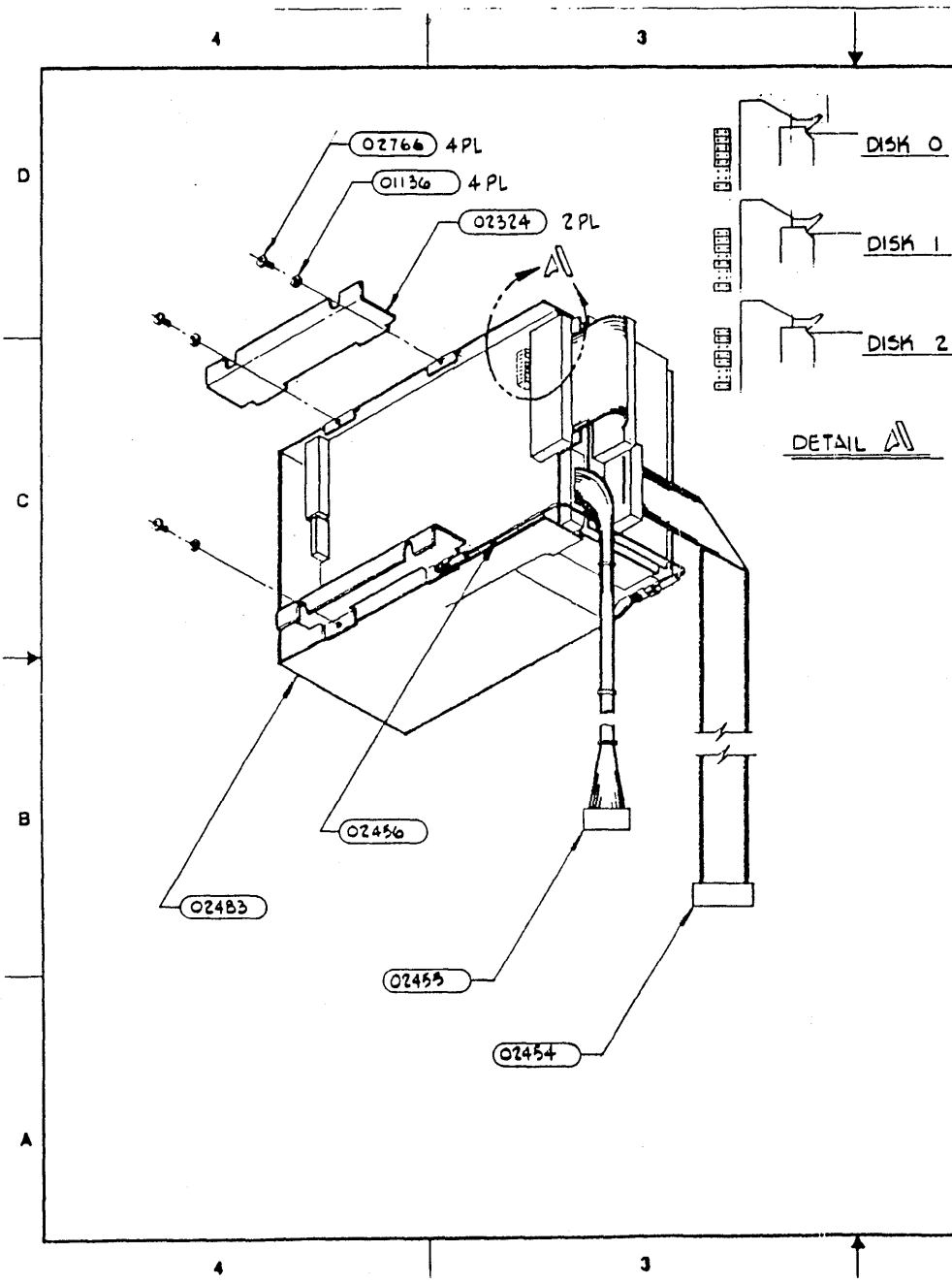

REVISION HISTORY AD-02453 A  
 A 26 JUNE 1987 INITIAL RELEASE--PRELIMINARY

REFERENCE DOCUMENTS  
 1. PR-99123 TORQUE REQUIREMENTS  
 2. LM-02453-00 LIST OF MATERIALS, ASSY DISK DRIVE 800

ASSEMBLY INSTRUCTIONS  
 1. Connect disk ground cable (82-02456-00) to tab on 170 MB disk drive (28-02483-00) as shown.  
 2. Fasten disk drive brackets (51-02124) using 4 X 8MM screws (36-02766-01) and 18 split lock washers (36-01136). The other end of the disk ground cable is fastened to a bracket as shown.  
 3. Connect disk drive control cable (82-02454-00) and disk drive power cable (82-02455-00) to drive.

SEE SHEET 2 FOR INSTALLATION

A B T E O P E R A T I O N S P R O C E D U R E				
DOC NUMBER	REV	DESCRIPTION	DATE	SHEET
AD-02453	A	ASSY, DISK DRIVE, 800	26 JUNE 1987	1 of 2

A P P R O V A L S				
ORIGINATOR	<i>J. F. ...</i>	<i>6/24/87</i>	VF OPERATIONS	_____
DRAFTING BY	<i>A. ...</i>	<i>6/24/87</i>	DTR ADV HPG ENGR	_____
DTR	<i>J. M. ...</i>	<i>7/31/87</i>	DTR MANUFACTURING	<i>[Signature]</i>
DTR M/T	<i>P. Nolan</i>	<i>7/1/87</i>	DTR MATERIALS	<i>[Signature]</i>









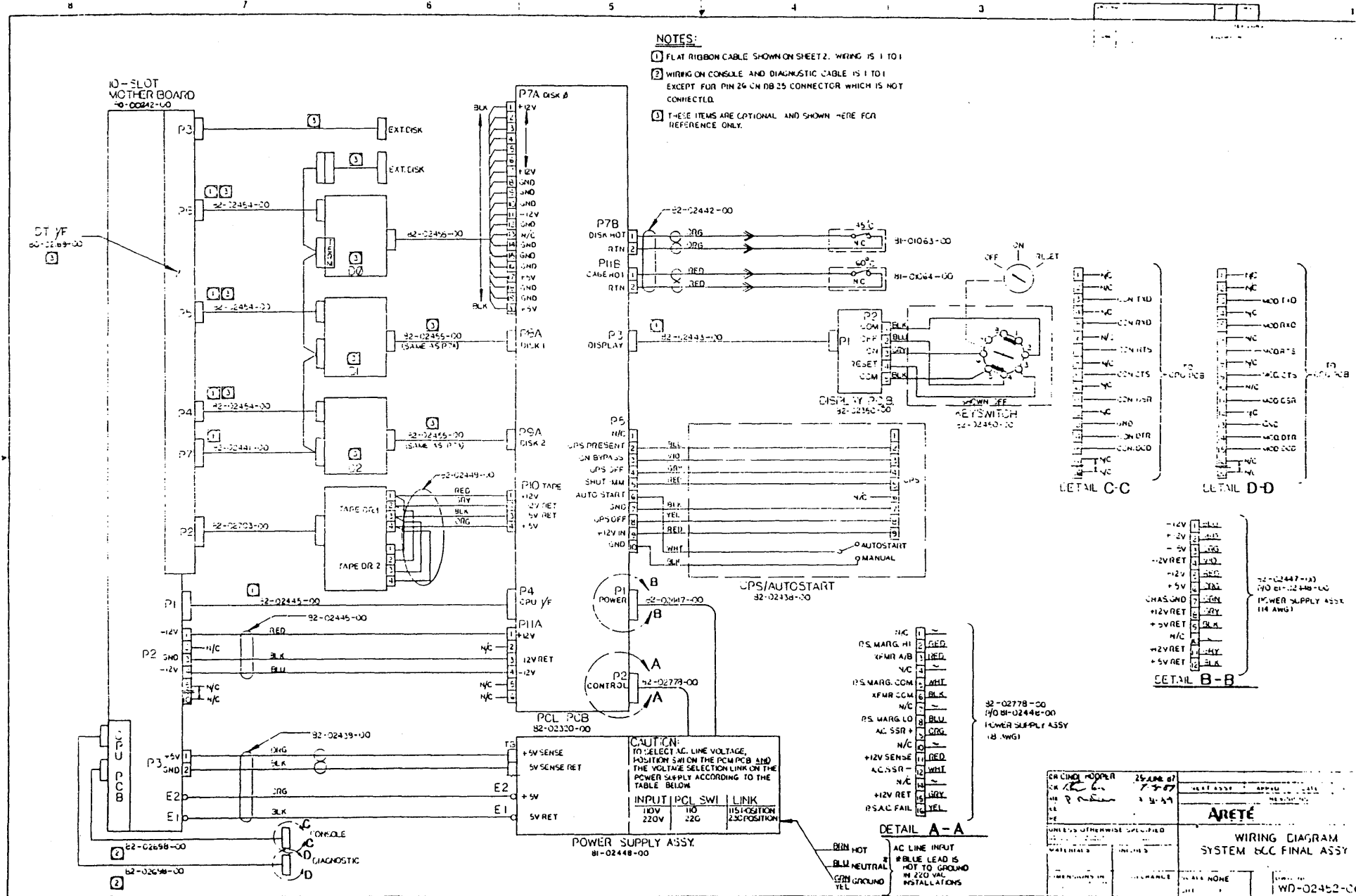

- NOTES:**
- 1 FLAT RIBBON CABLE SHOWN ON SHEET 2. WIRING IS 1 TO 1
  - 2 WIRING ON CONSOLE AND DIAGNOSTIC CABLE IS 1 TO 1 EXCEPT FOR PIN 24 ON DB 25 CONNECTOR WHICH IS NOT CONNECTED.
  - 3 THESE ITEMS ARE OPTIONAL AND SHOWN HERE FOR REFERENCE ONLY.

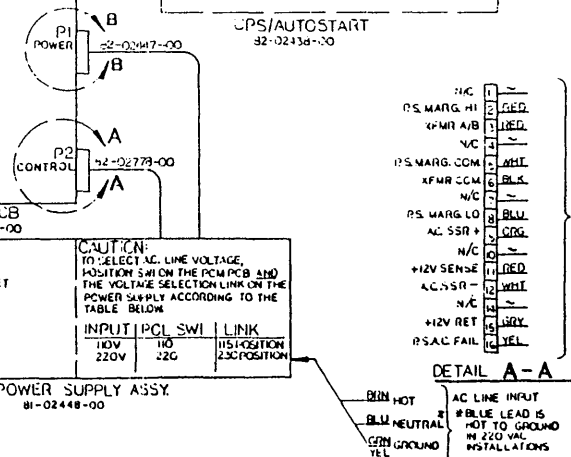
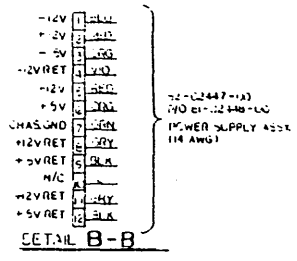
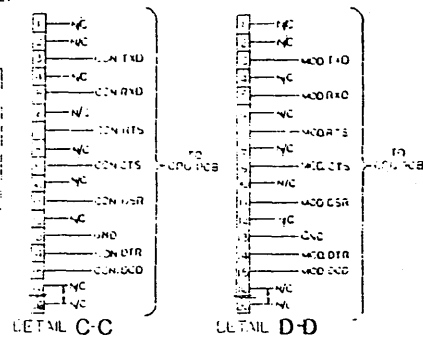

- PS. MARG. HI
- PS. MARG. COM
- PS. MARG. LO
- AC SSR +
- +12V SENSE
- AC SSR -
- +12V RET
- RSAC FAIL

CR. CIND. NUMBER	25-000-07
DATE	7-3-87
BY	3-3-87
CHKD	
REV	
<b>ARETE</b>	
<b>WIRING DIAGRAM SYSTEM BCC FINAL ASSY</b>	
REVISIONS	DATE
1	
2	
3	
4	
5	
6	
7	
8	
9	
10	
11	
12	
13	
14	
15	
16	
17	
18	
19	
20	
21	
22	
23	
24	
25	
26	
27	
28	
29	
30	
31	
32	
33	
34	
35	
36	
37	
38	
39	
40	
41	
42	
43	
44	
45	
46	
47	
48	
49	
50	
51	
52	
53	
54	
55	
56	
57	
58	
59	
60	
61	
62	
63	
64	
65	
66	
67	
68	
69	
70	
71	
72	
73	
74	
75	
76	
77	
78	
79	
80	
81	
82	
83	
84	
85	
86	
87	
88	
89	
90	
91	
92	
93	
94	
95	
96	
97	
98	
99	
100	



REVISED		DESCRIPTION	DATE	BY
02	REVISED PER PCO # 221		11/8/82	EA
03	PCO # 224			
04	REVISED PER PCO # 251		1/13/89	
25	REV ROLL PCO 253 + 259			
A	PRDD REL PER ECO # 1094		4-6-89	DE
B	REVISED PER ECO # 1541		27-90	DE
C	REV ROLL PER ECO # 1682			

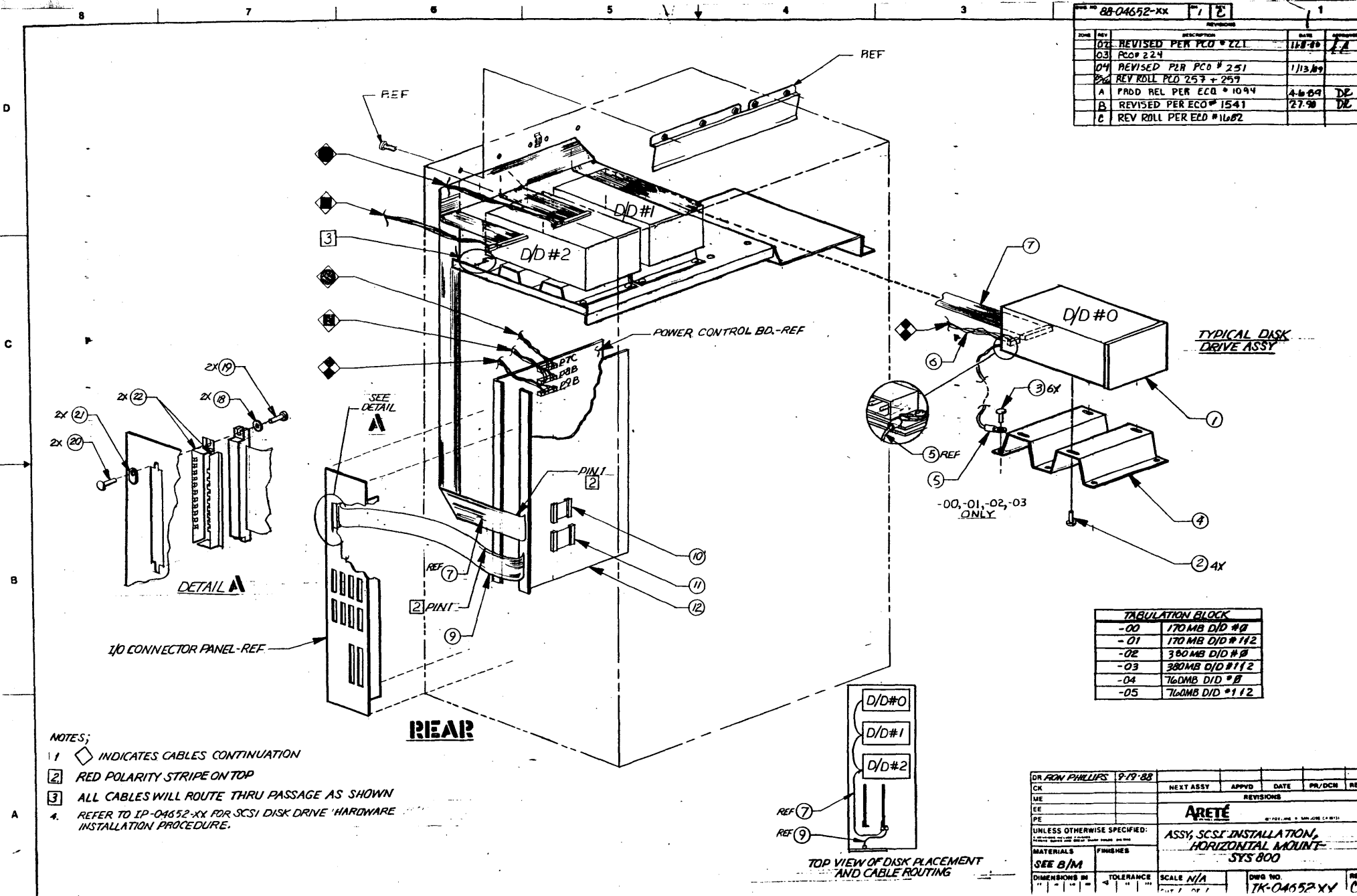

TYPICAL DISK DRIVE ASSY

TABULATION BLOCK	
-00	170 MB D/D #0
-01	170 MB D/D #1/2
-02	380 MB D/D #0
-03	380 MB D/D #1/2
-04	760 MB D/D #0
-05	760 MB D/D #1/2

- NOTES:
- 1  $\diamond$  INDICATES CABLES CONTINUATION
  - 2 RED POLARITY STRIPE ON TOP
  - 3 ALL CABLES WILL ROUTE THRU PASSAGE AS SHOWN
  - 4 REFER TO IP-04652-XX FOR SCSI DISK DRIVE HARDWARE INSTALLATION PROCEDURE.

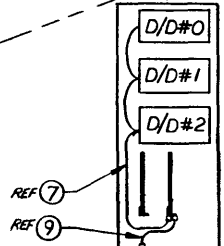

DR. RON PHILLIPS	9/9/88	NEXT ASSY	APPVD	DATE	PR/DCN	REV
CK		REVISIONS				
ME		ARETE				
EE		UNLESS OTHERWISE SPECIFIED: ASSY, SCSI INSTALLATION, HORIZONTAL MOUNT, SYS 800				
PE		MATERIALS FINISHES				
SEE B/M		DIMENSIONS #1		TOLERANCE		SCALE N/A
				DWB NO. 7K-04652-XX		REV C



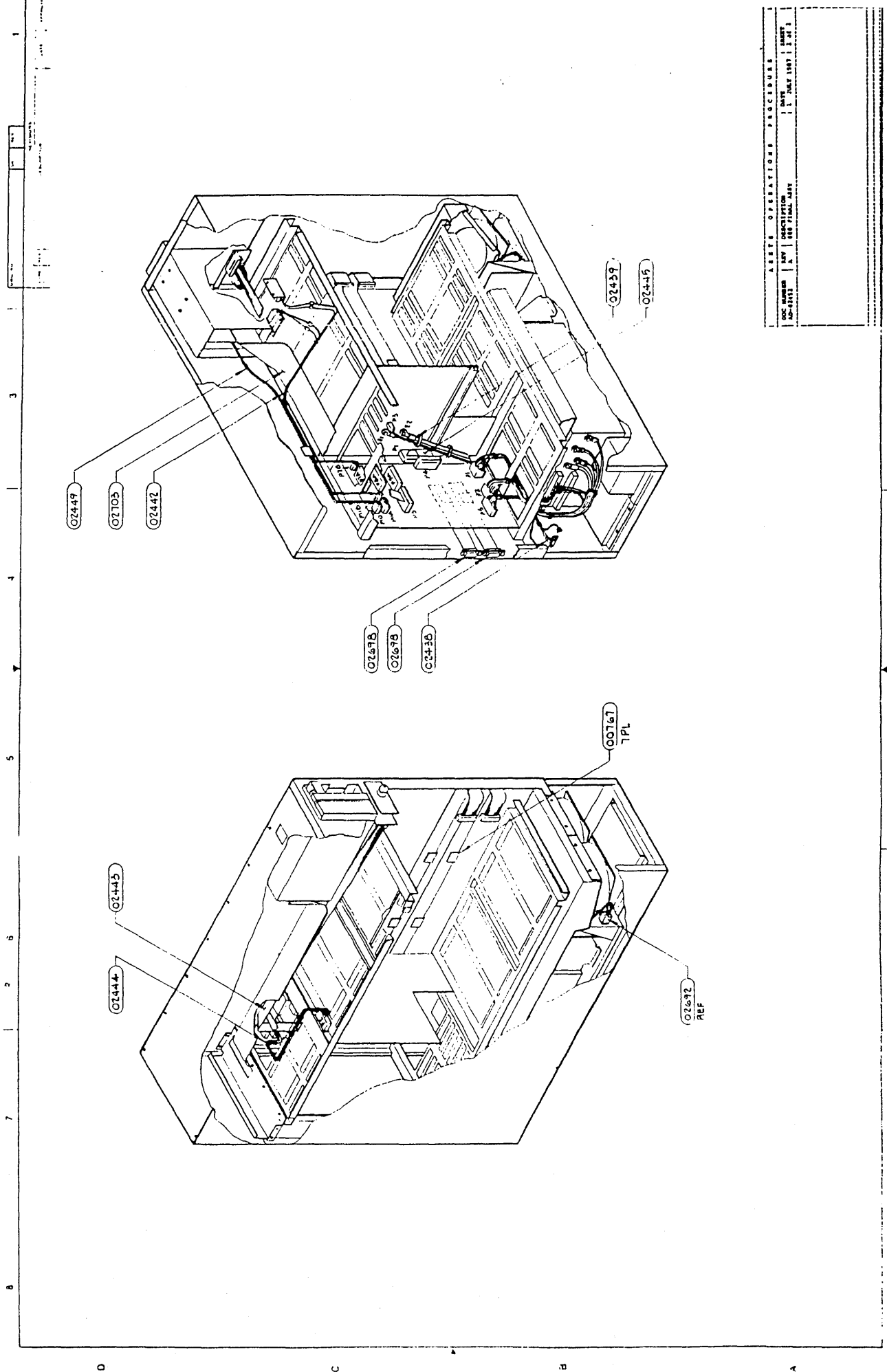
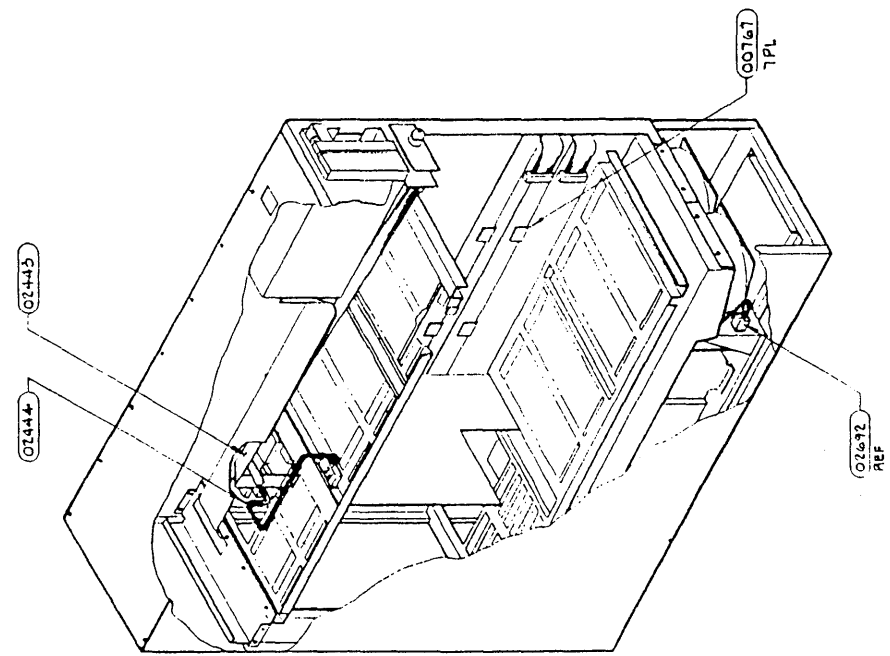
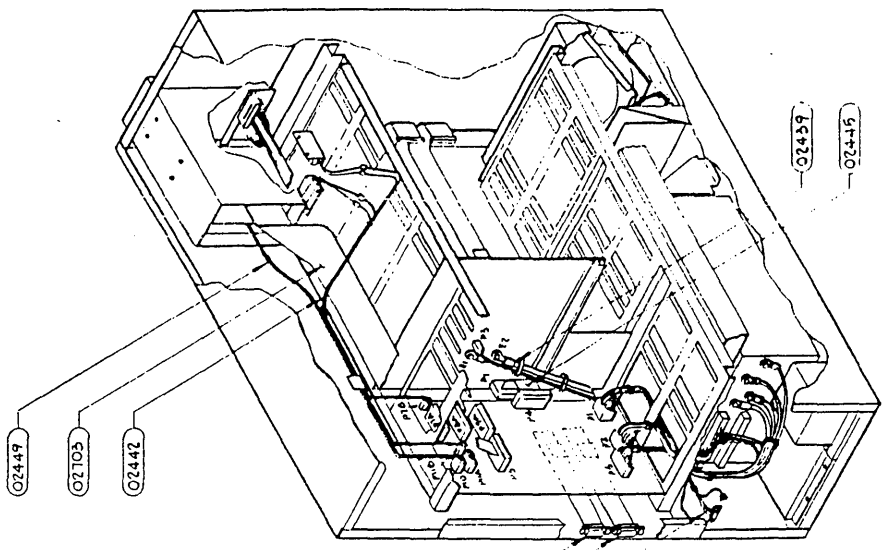









NOTES: UNLESS OTHERWISE SPECIFIED  
 PART NUMBERS/NAMES ARE SHOWN FOR REFERENCE ONLY  
 MAY NOT APPEAR ON PART BODIES. REFER TO INDIVIDUAL  
 ASSY DWGS FOR EXACT PART ORIENTATIONS.  
 CONNECTION TYPES ARE DENOTED BY THE FOLLOWING  
 SYMBOLS:  
 — QUICK DISCONNECT  
 ○ RING TONGUE  
 ○ SOLDER  
 ○ SPACE SUG  
 REFER TO:  
 LM-0244-B  
 AD-0244-B

UNLESS OTHERWISE SPECIFIED  
 MATERIAL PART NUMBER QUANTITY IN STOCK  
 DATE 1 OF 1  
 WIRING DIAGRAM  
 ASSEMBLY, POWER SUPPLY 300  
 WD-0244-B

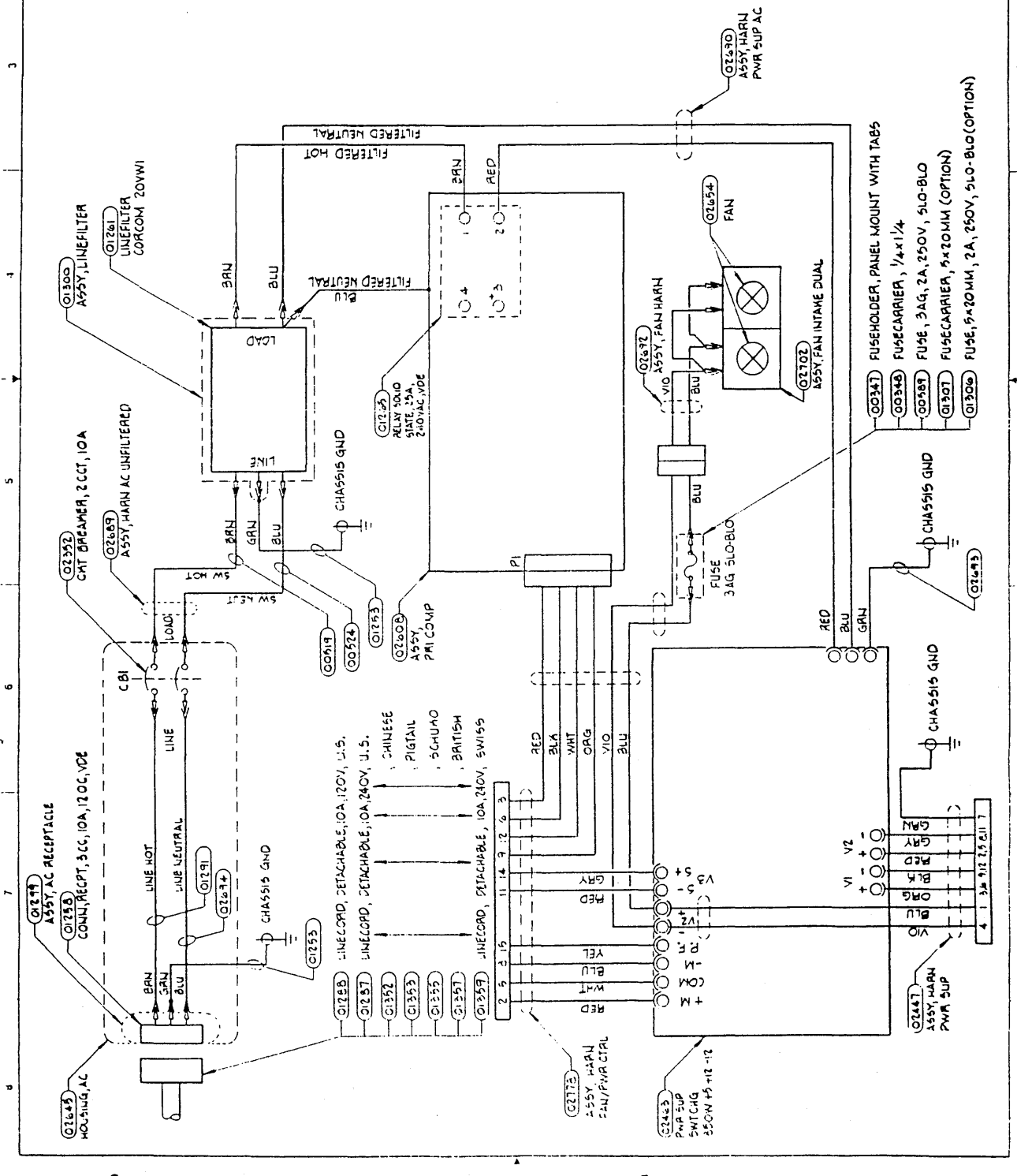







REFERENCE DOCUMENTS  
 1. 14-59111 TORQUE REQUIREMENTS  
 2. 14-59112 ELECTRICAL CONNECTIONS  
 3. WP-21418-08 WELDING GUIDELINES, WELDING SYMBOLS, AND WELDING PROCEDURES

ASSEMBLY INSTRUCTIONS  
 1. Apply internal compound (14-00177) to the base of the solid state relay (14-21151) and fasten to the base power supply chassis (14-21151-01) using the screws (14-00181), (14-00182), (14-00183) and (14-00184) adjacent to the fuse.  
 2. Fasten the primary component PCB assembly (14-21428-01) to the chassis (14-21151-01) using three 4-12 x 1/8 screws (14-00181).  
 3. Attach the ring tongue of brown jumper (14-21491) to the PCB assembly and relay position 1) with an 4-12 x 1/8 (14-00181) screw as shown.  
 4. Attach the red lead of AC harness (14-21491-01) to the PCB assembly and relay position 2) with an 4-12 x 1/8 (14-00181) screw as shown.  
 5. Attach the blue lead of AC harness (14-21491-01) to the PCB assembly and relay position 3) with an 4-12 x 1/8 (14-00181) screw as shown.  
 6. Insert fuse holder (14-00181) through the chassis and secure with nylon nut.  
 7. Insert 2 amp fuse (14-00181) in fuse carrier (14-00181) and fasten into fuse holder.  
 8. Slip approximately 1-1/2 of clear insulatable tubing (14-00181) over the fuse holder.  
 9. Slip the end of (14-21778-01) (on power control harness to rear of fuse holder (14-00181)).  
 10. Strip 1/2-inch outer conductor of the power control harness in position in the chassis and secure conductor into 1/2 of the PCB board.  
 11. Slide the insulatable tubing down over the tabs on the fuse holder, and use a heat gun to strain tubing around it.  
 12. Remove factory installed sense cables from power supply terminals, and install sense cable (14-21491-01) to chassis using four 4-12 x 1/8 (14-00181) screws (14-21491-01) in round hole of line filter mount.  
 13. Connect AC harness to power supply bracket above.  
 14. Connect brown jumper (14-21491-01) to power supply bracket, brass and blue leads to the chassis stud using a 1/8 inch nut (14-20348).  
 15. Connect fan/control harness (14-21778-01) and power supply harness (14-21491-01) to the power supply bracket block as shown in WP-21418.  
 16. Strip nylon bushing (14-21778-01) in round hole of line filter mount.  
 17. Fasten line filter assembly (14-21100) to line filter mount using four 4-12 x 1/8 screws (14-20348).  
 18. Mount the end of unfiltered AC harness (14-21491-01) through the hole in the line filter mount and connect to the line end of the filter.  
 19. Route the unfiltered AC harness through the notch in the base of the filter (14-21100) and connect to the line end of the filter using four 4-12 x 1/8 screws (14-20348).  
 20. Attach the brown jumper from relay position 1 to the line filter lead end. Attach the blue lead of the power supply harness (14-21491-01) to the other lead end on the filter.  
 21. Using nylon cable clamp (14-00181) fastened by 4-12 x 1/8 screws (14-20348) with a heat washer (14-00181) secure the filter supply harness to the chassis using four 4-12 x 1/8 screws (14-20348) and 1/8 (14-00181) flat washer. Flat washer (14-00181) and 1/8 (14-00181) screw (14-20348) are shown in WP-21418.  
 22. Pick up the AC mounting (14-21491-01) and fasten the circuit breaker assembly (14-21151) using two 4-12 x 1/8 screws (14-20348). AC receptacle assembly (14-21151) and blue jumper (14-21491-01) between AC receptacle and the breaker and receptacle is shown in WP-21418.  
 23. Connect the remaining end of the unfiltered AC harness to the breaker as shown.  
 24. Fasten ground jumper of AC receptacle assembly to the lug on the chassis with a 1/8 inch nut.  
 25. Fasten the assembled AC harness to the chassis using four 4-12 x 1/8 screws (14-20348) and 1/8 (14-00181) flat washer. Flat washer (14-00181) and 1/8 (14-00181) screw (14-20348) are shown in WP-21418.  
 26. Route the unfiltered AC harness to the power supply using cable clamps as shown.  
 27. Fasten voltage select cover (14-21491-01) on the chassis using two 4-12 x 1/8 screws (14-00181).  
 28. Apply labels (14-01131, 14-01132, 14-01133, 14-01134) approximately where shown on chassis.

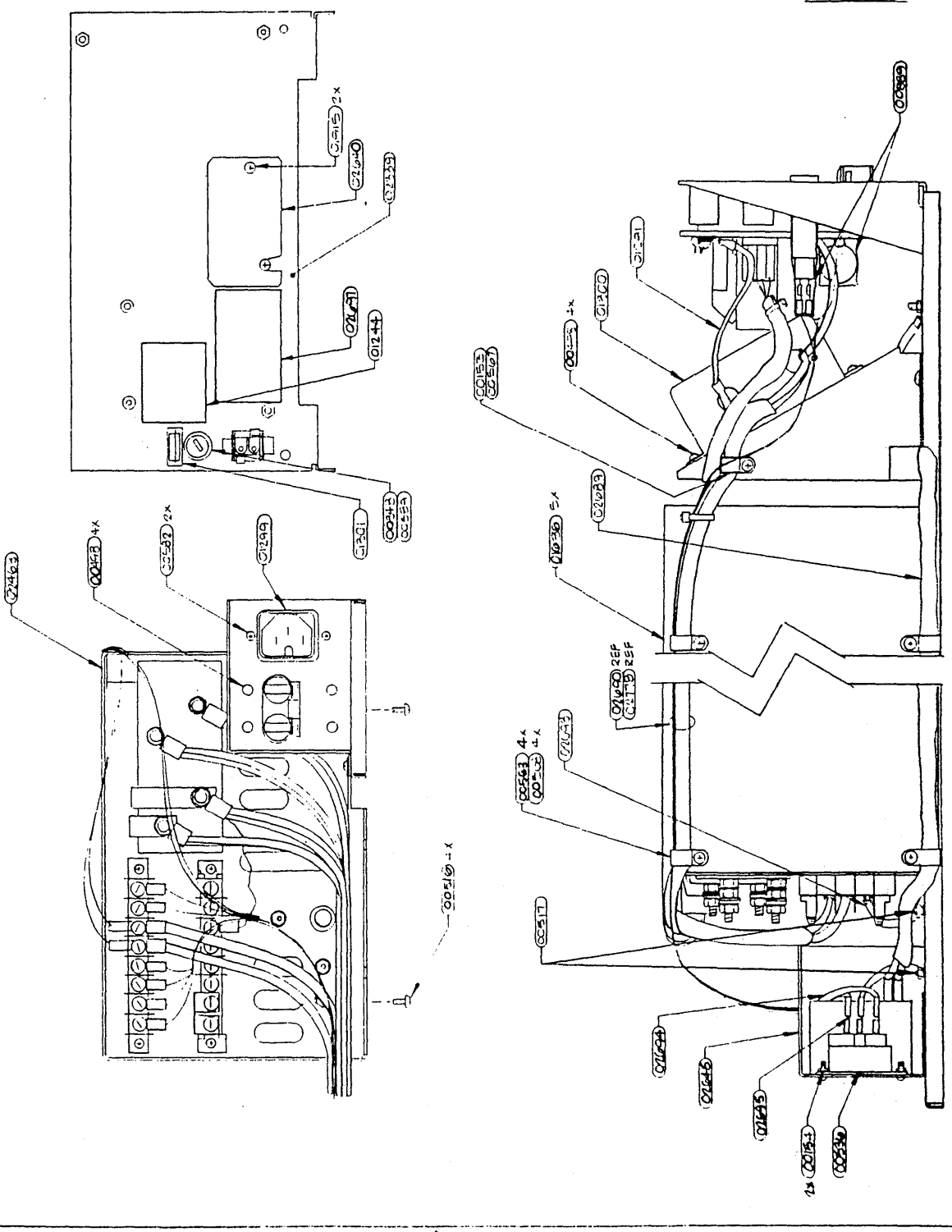

DATE OF OPERATION: \_\_\_\_\_  
 OPERATOR: \_\_\_\_\_  
 SIGNATURE: \_\_\_\_\_  
 CHECKED BY: \_\_\_\_\_  
 DATE: \_\_\_\_\_  
 14-59111 TORQUE REQUIREMENTS  
 14-59112 ELECTRICAL CONNECTIONS  
 WP-21418-08 WELDING GUIDELINES, WELDING SYMBOLS, AND WELDING PROCEDURES

509 CELL

710

3321

102698114



# Arix

## MODEL 850/1200 POWER CONFIGURATION CHART

### Instructions:

1. Fill in desired configuration of boards and other features in the NO. INSTALLED column.
2. Multiply the NO. INSTALLED by the POWER REQ'D and write the result in the TOTAL POWER column.
3. Add up the total number of boards and the total power. Be sure to include the tape drive and basic system in the total power.
4. Verify that your configuration is within the limitations listed below.

FEATURE	POWER REQ'D	x	NO. INSTALLED	=	TOTAL POWER
CPU-32	11	x		=	
CPU-32/25 MHz	14	x		=	
8 MB Memory	4	x		=	
32 MB Memory	5	x		=	
DMC-4/2	9	x		=	
DMC-4	12	x		=	
HSDT	14	x		=	
EDT	14	x		=	
GC-8	5	x		=	
EGC	6	x		=	
GC-16	12	x		=	
MAC/Excelan	6	x		=	
Total Boards: (19 BOARDS MAX)					
.25" Tape	3	x	1	=	3
168MB Disks	5	x		=	
337MB Disks	5	x		=	
690MB Disks	4	x		=	
824MB Disks	4	x		=	
Basic System	3	x	1	=	3
Total Power: (175 MAX POWER)					

### Configuration Limitations:

1. Total board count may not exceed 19.



2. Total power number may not exceed 175
3. 4 168MB or 337 MB disk drives maximum internal in a system cabinet.
4. If ANY 690 MB or 824 MB disk drives are included the maximum for ALL types is 3 drives internal in a system cabinet.
5. Must select either a DMC4/2 or DMC4.
6. If a DMC-4/2 is used there are 2 controllers (HSDT, EDT) maximum per system.
7. If a DMC-4 is used there are a maximum of 4 controllers (HSDT, EDT) per system.
8. A system may have up to 4 EDTs, but one of the four must support 168MB drives ONLY.
9. CPU plus Memory boards is 6 maximum.
10. Maximum of 3 CPU-32/25s per system.
11. Maximum of 16MB of memory with CPU-32; maximum of 64MB of memory with CPU-32/25MHz.

This document will become EFFECTIVE in December 1988 after the introduction of an upgraded power supply.

