

800-258-1952

SER # 4806

692-6030

744-1244 - Sunnyvale

# TECHNICAL MANUAL

## MODEL 306 PRINTER

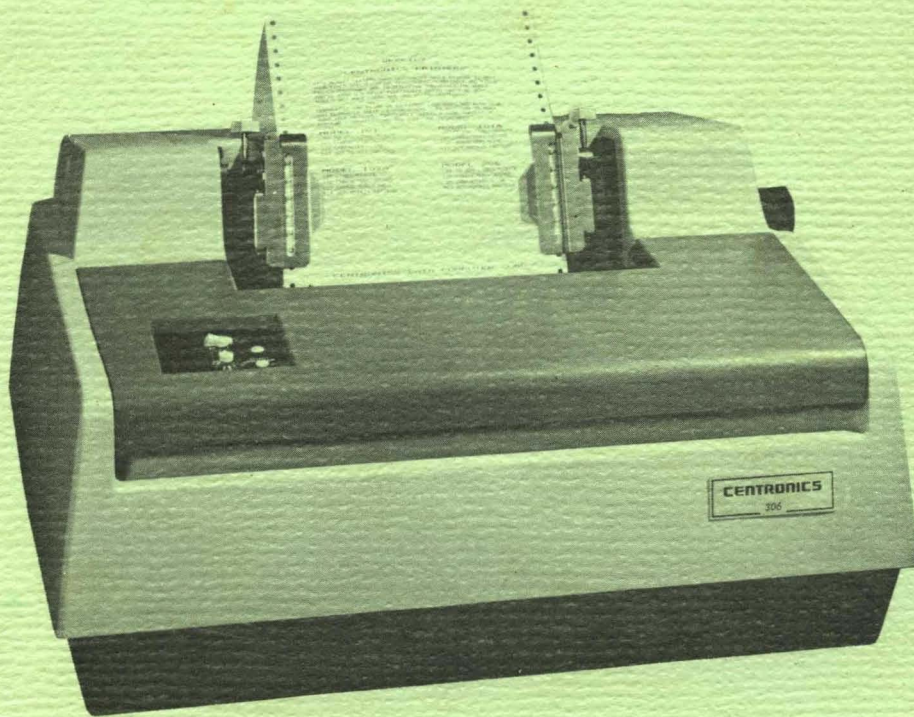

MARCH 1976

Centronics No. 37400040 - Rev F

# CENTRONICS

data computer corp.

HUDSON, NEW HAMPSHIRE 03051

TELEPHONE (603) 883-0111

# TECHNICAL MANUAL

## MODEL 306 PRINTER

REVISION F

MARCH 1976

THE INFORMATION CONTAINED HEREIN IS  
PROPRIETARY AND IS NOT TO BE RELEASED  
OR REPRODUCED WITHOUT WRITTEN PER-  
MISSION OF CENTRONICS data computer corp.

### **CENTRONICS**

data computer corp.

HUDSON, NEW HAMPSHIRE 03051

TELEPHONE (603) 883-0111

## TABLE OF CONTENTS

### SECTION 1 INTRODUCTION

<u>Section</u>	<u>Page</u>
1.1 GENERAL DESCRIPTION . . . . .	1-2
1.2 LOGIC FLOW DIAGRAM . . . . .	1-2
1.3 PRINTER OPERATION . . . . .	1-3
1.3.1 Character Printing . . . . .	1-3
1.3.2 Paper Movement. . . . .	1-4
1.3.3 Special Functions. . . . .	1-5
1.4 SYSTEM FEATURES . . . . .	1-6
1.4.1 Specifications Summary . . . . .	1-6
1.4.2 Standard and Optional Features . . . . .	1-7
1.5 PHYSICAL DESCRIPTION . . . . .	1-7

### SECTION 2 AND 3 INSTALLATION AND OPERATION

2.1 SITE PREPARATION . . . . .	2-1
2.2 SHIPPING CRATE . . . . .	2-2

### SECTION 4 THEORY OF OPERATION

4.1 INTRODUCTION . . . . .	4-1
4.2 BASIC TIMING . . . . .	4-1



TABLE OF CONTENTS (cont'd)

<u>Section</u>	<u>Page</u>
4.3 INITIALIZING THE PRINTER . . . . .	4-3
4.3.1 Prime . . . . .	4-3
4.3.2 Select . . . . .	4-5
4.4 DATA INPUT . . . . .	4-6
4.4.1 Data Input Timing. . . . .	4-6
4.4.2 Busy . . . . .	4-9
4.4.3 Function Decoder . . . . .	4-10
4.5 SHIFT REGISTER (BUFFER) . . . . .	4-12
4.6 CHARACTER PRINTING . . . . .	4-14
4.6.1 Initiating the Printer Operation. . . . .	4-14
4.6.2 Character Registration and Timing . . . . .	4-17
4.6.3 Character Generator (ROM) . . . . .	4-18
4.6.4 Print Head Operation. . . . .	4-21
4.6.5 Power Driver Circuits . . . . .	4-22
4.7 PAPER MOVEMENT . . . . .	4-23
4.7.1 Line Feed . . . . .	4-25
4.7.2 Form Feed . . . . .	4-26
4.7.3 Vertical Tab . . . . .	4-28
4.7.4 Vertical Format Unit (Optional) . . . . .	4-28
4.7.5 Line Feed Solenoid Driver . . . . .	4-29
4.8 SPECIAL FUNCTIONS . . . . .	4-30
4.8.1 Bell (Optional) . . . . .	4-30
4.8.2 Delete . . . . .	4-30
4.8.3 +35V Power Supply (Unregulated) . . . . .	4-31
4.8.4 Motor Control (Optional) . . . . .	4-31
4.9 POWER SUPPLIES . . . . .	4-33
4.9.1 +5V Regulator . . . . .	4-34
4.9.2 +12V and -12V Regulators . . . . .	4-34
4.9.3 +35V Power Supply (Unregulated) . . . . .	4-34
4.10 OUTPUTS FROM LSI CHIPS (ME25 AND ME16) . . . . .	4-38
4.10.1 LSI Chip ME25 . . . . .	4-38
4.10.2 LSI Chip ME16 . . . . .	4-41



TABLE OF CONTENTS (cont'd)

SECTION 5  
REMOVAL REPLACEMENT AND ADJUSTMENT PROCEDURES

<u>Section</u>	<u>Page</u>
5.1 INTRODUCTION. . . . .	5-1
5.2 MECHANICAL ASSEMBLIES. . . . .	5-1
5.2.1 Carriage Mechanism . . . . .	5-2
5.2.2 Platen (Figure AB) . . . . .	5-6
5.2.3 Paper Pan (Figure AC) . . . . .	5-9
5.2.4 Driving Mechanism (Figure AD, Part 1). . . . .	5-11
5.2.5 Driving Mechanism (Figure AE, Part 2). . . . .	5-14
5.2.6 Idler Pulley Assembly (Figure AF) . . . . .	5-21
5.2.7 Reed Switch (AG) . . . . .	5-24
5.2.8 Printer Base (Figure AH) . . . . .	5-27
5.2.9 Frame (Figure AI) . . . . .	5-27
5.2.10 Paper Feed (Figure AJ). . . . .	5-29
5.2.11 Pin Feed Unit (Figure AK). . . . .	5-32
5.2.12 Ribbon Feed (Figure AL) . . . . .	5-34
5.2.13 Cover (Figure AM) . . . . .	5-45
5.2.14 Operator Panel (Figure AN) . . . . .	5-45
5.2.15 Electrical Components (Figure AO) . . . . .	5-46
5.2.16 Electrical Components (Figure AP) . . . . .	5-46
5.2.17 Electrical Components (Figure AQ) . . . . .	5-46
5.2.18 Print Head and Associated Assemblies (Fig. 8-19) . . . . .	5-46
5.2.19 Motor Control Assembly Option . . . . .	5-51
5.2.20 Vertical Format Unit (VFU) - Option . . . . .	5-52
5.2.21 Printer Drive Mechanism, Model 306. . . . .	5-54

SECTION 6  
MAINTENANCE

6.1 ADJUSTMENTS . . . . .	6-1
6.2 PREVENTIVE MAINTENANCE . . . . .	6-2
6.3 TROUBLESHOOTING GUIDE. . . . .	6-8

SECTION 7  
DRAWINGS AND LISTS OF MATERIALS, ELECTRICAL

7-1

TABLE OF CONTENTS (cont'd)

<u>Section</u>		<u>Page</u>
	SECTION 8	
	MECHANICAL DRAWINGS AND PARTS LISTS	8-1
	APPENDICES	
A	SIGNAL GLOSSARY. . . . .	A-1
B	PARALLEL INTERFACE SPECIFICATIONS. . . . .	B-1

LIST OF ILLUSTRATIONS

<u>Figure</u>		<u>Page</u>
1-1	Model 306 Printer (Top and VFU Covers Removed). . . . .	1-2
1-2	Basic Block Diagram. . . . .	1-3
1-3	Printing the Letter (H) . . . . .	1-4
1-4	Print Head Components . . . . .	1-4
1-5	Paper Movement Mechanism . . . . .	1-4
1-6	Left Front View of 306 . . . . .	1-8
1-7	Right Front View of 306 . . . . .	1-8
1-8	Rear View of 306 . . . . .	1-9
1-9	Rear View (306 Logic/P.S. Board Removed). . . . .	1-9
2-1	Printer Dimensions . . . . .	2-1
4-1	Model 306 - Block Diagram. . . . .	4-2
4-2	Prime Timing . . . . .	4-4
4-3	Input Data Timing - No Busy Condition . . . . .	4-7
4-4	Input Data Timing - Causing Busy Condition . . . . .	4-8
4-5	Forward Clutch Interconnection Diagram . . . . .	4-15
4-6	Character Timing . . . . .	4-16
4-7	Normal and Elongated Characters. . . . .	4-20
4-8	Print Head Timing . . . . .	4-22
4-9	Line Feed Timing . . . . .	4-25
4-10	Form Feed and Vertical Tab Timing . . . . .	4-27
4-11	VFU Tape Reader Amplifier (Located in VFU) . . . . .	4-29
4-12	Motor Control Timing . . . . .	4-32
4-13	+5 Volt Regulator Interconnection Diagram . . . . .	4-35
4-14	$\pm 12V$ Regulators Interconnection Diagram . . . . .	4-36
4-15	+35V Unregulated Supply Interconnection Diagram . . . . .	4-37
5-1	Carriage Movement Adjustments . . . . .	5-5
5-2	Timing Fence Mounting, Model 306 . . . . .	5-8
5-3	Adjustment of Timing Belt (AD-15) (View from back of printer, forward) . . . . .	5-13
5-4	Adjustment of Timing Belt (AD-41) (View from back of printer, forward) . . . . .	5-14



LIST OF ILLUSTRATIONS (cont'd)

<u>Figure</u>		<u>Page</u>
5-5	Main Motor Belt Adjustment (AE-9). . . . .	5-18
5-6	Forward Clutch Adjustment (Air-Gap) . . . . .	5-19
5-7	Bushing End-Play Adjustment for (Forward Clutch Shaft Air-Gap and Preload Clutch) . . . . .	5-19
5-7A	Location of Drive Pulley Bracket (AE-21) . . . . .	5-20
5-8	Torque Limiting Device (Brake) . . . . .	5-24
5-9	Reed Switch Assembly, Left (AG) . . . . .	5-25
5-10	Left Reed Switch (AG-1) Static-Adjustment . . . . .	5-26
5-11	Two Adjustments, Paper Feed Mechanism (AJ). . . . .	5-31
5-12	Locating Idler Pulley Assembly . . . . .	5-37
5-13	Locating Dimension for Ribbon Feed Rack. . . . .	5-38
5-14	Rack and Pinion Adjustment, Ribbon Mechanism . . . . .	5-39
5-15	Locating Dimension for Left Ribbon Holder Plate with Respect to Rear Guide Bar . . . . .	5-40
5-16	Locating Dimension for Right Ribbon Holder Plate with Respect to Rear Guide Bar . . . . .	5-40
5-17	Left Operator and Stopper Adjustment. . . . .	5-41
5-18	Ribbon Feed Plate and Guide Bar (Left Side) . . . . .	5-42
5-19	Adjusting Nuts for Right Pawl Operator Movement . . . . .	5-42
5-20	Right Pawl Operator Starting Position . . . . .	5-43
5-21	Pawl, Ratchet and Cam Movement. . . . .	5-44
5-22	Spur on Left Releaser (AL-174) and Roller (AL-46) . . . . .	5-44
5-23	Fibre Optics Head, Adjustment from Optic Fence . . . . .	5-50
5-24	Fibre Optics Head Alinement and Flexible Timing Fence . . . . .	5-50
5-25	Motor Control Location and Installation. . . . .	5-51
5-26	Removal/Replacement of Drive Shaft 63060142-5001 and Couplings 63060144-2002 for VFU Assembly . . . . .	5-53
5-27	Paper Tape Reader Adjustment . . . . .	5-54
5-28	Printer Drive Mechanism, Model 306 . . . . .	5-55
7-1	Schematic Diagram, Logic/P.S. Board (+5V) (Sheet 1 of 4)	7-3
7-2	Schematic Diagram, Logic/P.S. Board (+5V) (Sheet 2 of 4)	7-4
7-3	Schematic Diagram, Logic/P.S. Board (+5V) (Sheet 3 of 4)	7-5
7-4	Schematic Diagram, Logic/P.S. Board (+5V) (Sheet 4 of 4)	7-6
7-5	Schematic Diagram, Power Driver Board (Sheet 1 of 2) . . . . .	7-7
7-6	Schematic Diagram, Power Driver Board (Sheet 2 of 2) . . . . .	7-8

LIST OF ILLUSTRATIONS (cont'd)

<u>Figure</u>		<u>Page</u>
7-7	Schematic Diagram, Video Amplifier. . . . .	7-9
7-8	Interconnection Diagram, Connector Card . . . . .	7-10
7-9	Wiring Diagram, Printer Mechanism . . . . .	7-11
7-10	Schematic Diagram, Elapsed Time Indicator (Option) . . . . .	7-12
7-11	Logic/Power Supply Board Connections . . . . .	7-13
7-12	PC Board Ass'y, Logic/Power Supply Board (Sheet 1 of 2). . . . .	7-15
7-13	PC Board Ass'y, Logic/Power Supply Board (Sheet 2 of 2). . . . .	7-16
7-14	PC Board Ass'y, Power Driver Board (Sheet 1 of 2). . . . .	7-20
7-15	PC Board Ass'y, Power Driver Board (Sheet 2 of 2). . . . .	7-21
7-16	PC Board Ass'y, Video Amplifier and Cable Ass'y . . . . .	7-23
7-17	PC Board Ass'y, Connector Card . . . . .	7-25
7-18	PC Board Ass'y, Elapsed Time Indicator (Option) . . . . .	7-27
7-19	Cable Ass'y, Data Input . . . . .	7-29
7-20	Cable Ass'y, Computer Input . . . . .	7-31
8-i	Model 306 Subassemblies . . . . .	8-3
8-1	Carriage - AA . . . . .	8-5
8-2	Platen - AB . . . . .	8-7
8-3	Paper Pan - AC . . . . .	8-9
8-4	Driving Mechanism (Part 1 of 2) - AD . . . . .	8-11
8-5	Driving Mechanism (AE, Part 2) (This Drawing Applies to Air-Gap Clutch Only) . . . . .	8-13
8-5A	Driving Mechanism (AE, Part 2) (This Drawing Applies to Preload Clutch Only) . . . . .	8-15
8-6	Idler Pulley - AF . . . . .	8-17
8-7	Reed Switch - AG . . . . .	8-19
8-8	Base - AH . . . . .	8-21
8-9	Frame - AI . . . . .	8-23
8-10	Paper Feed - AJ . . . . .	8-25
8-11	Pin Feed - AK. . . . .	8-29
8-12	Ribbon Feed - AL (Part 1 of 2) . . . . .	8-31
8-13	Ribbon Feed - AL (Part 2 of 2) . . . . .	8-32
8-14	Cover - AM . . . . .	8-35
8-15	Operator Panel - AN. . . . .	8-37

LIST OF ILLUSTRATIONS (cont'd)

<u>Figure</u>		<u>Page</u>
8-16	Electrical Components (Part 1 of 3) - A0 . . . . .	8-39
8-17	Electrical Components (Part 2 of 3) - AP . . . . .	8-41
8-18	Electrical Components (Part 3 of 3) - AQ . . . . .	8-43
8-19	Print Head and Associated . . . . .	8-45
8-20	Tape Reader Assembly 68060125-5003 (Option) . . . . .	8-47
8-20A	Tape Reader Assembly 68060125-5002, (Option) (Alternate).	8-49

TABLES

4-1	306 Special Function . . . . .	4-8
-----	--------------------------------	-----

Note

*Refer to the Engineering Change Notice (ECN) sheets shipped with the printer for changes made to the printer which have not yet been incorporated into the technical manual. Always keep these Engineering Change Notice sheets with the manual.*

Note

*Revision level indications at the lower right-hand corner of a page reflect at what revision of the manual that page was updated.*



## SECTION 1 INTRODUCTION

This manual describes the Model 306 printer, manufactured by Centronics Data Computer Corporation. It provides general information, detailed theory of operation and maintenance information enabling field service personnel to service the printer. For serial input or other detailed interface information, a separate document for each interface is published for your reference.

The manual is subdivided into eight sections, each with its specific purpose.

- Section 1 - INTRODUCTION, introduces the reader to the scope and content of the manual, and provides the reader with a general description of the printer.
- Section 2 - INSTALLATION, contains unpacking and installation instructions for the printer.
- Section 3 - OPERATION, describes the use of all operator controls and indicators.
- Section 4 - THEORY OF OPERATION, contains a detailed description of each major operation performed by the printer electronics, including flow charts, timing diagrams and circuit diagrams.
- Section 5 - REMOVAL, REPLACEMENT AND ADJUSTMENT PROCEDURES, includes step-by-step removal and replacement procedures for all major assemblies and sub-assemblies in the printer.
- Section 6 - MAINTENANCE, includes electrical adjustments, preventive maintenance procedures, and a troubleshooting guide.
- Section 7 - ELECTRICAL DRAWINGS AND LIST OF MATERIALS, contains a complete set of schematic, wiring and component board layout diagrams and their associated list of materials for the electrical portion of the printer.
- Section 8 - MECHANICAL DRAWINGS AND PARTS LISTS, includes all printer assembly drawings and their associated part lists for the mechanical portion of the printer.

At the end of the manual are several appendices which include a glossary of signal mnemonics, standard 5 x 7 and optional 9 x 7 character set, and parallel interface specifications.

### 1.1 GENERAL DESCRIPTION (Figure 1-1)

The Model 306 printer is a medium speed impact printer which uses a standard 5 x 7 or optional 9 x 7 dot matrix for character generation.

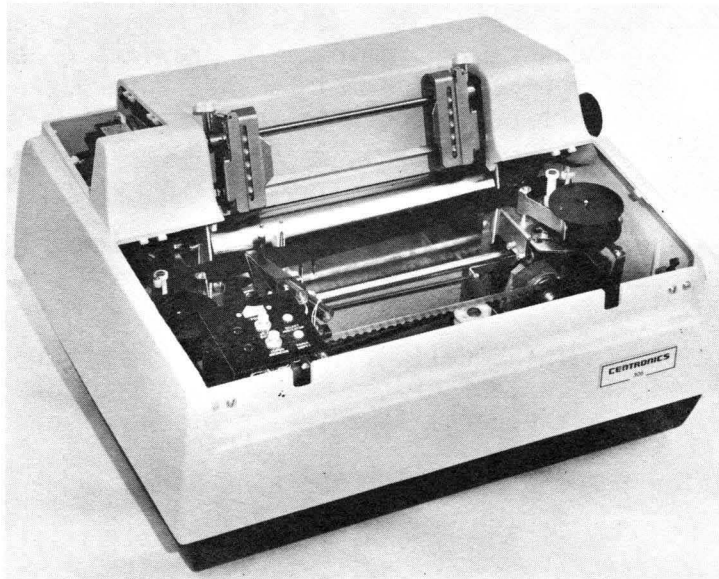

Figure 1-1. MODEL 306 PRINTER (TOP AND VFU COVERS REMOVED)

The unit prints at a rate of 120 characters per second, which is approximately one full 80-character line per second (including carriage return time). Paper is sprocket-fed, and paper widths from 4 inches to 9½ inches can be accommodated. The printer can produce one original and four copies. Standard print format consists of 10 characters per inch horizontally and 6 lines per inch vertically.

### 1.2 LOGIC FLOW DIAGRAM (Figure 1-2)

The standard printer contains an 80-character buffer. For serial data inputs, optional serial interfaces allow data to be received at rates from 100 to 9600 baud. Several other optional interfaces are available as required by the user.

Once a line of printable characters is stored in the buffer, head motion is initiated by activating the forward clutch, causing the print head to move from left to right across the paper. With the head in motion, data is transmitted from the buffer to the character generator. From there, character write pulses are sent to the driver circuits, which energize the print head solenoids causing the print wires to form the characters on the paper.

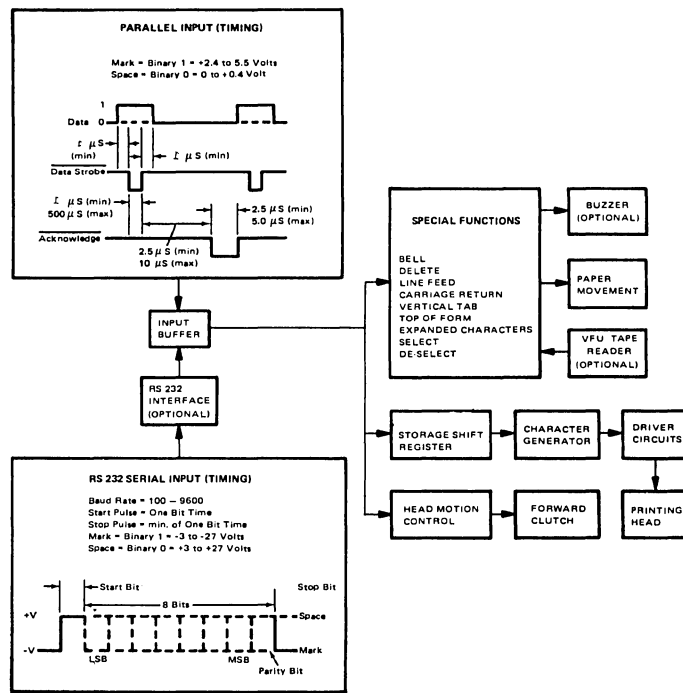

Figure 1-2. BASIC BLOCK DIAGRAM

Paper movement is initiated by a line feed, vertical tab and form feed function. In the standard 306 printer, vertical form movement is software controlled by means of line count pulses, rather than hardware-controlled. However, an optional vertical format unit, (VFU) is available for hardware-controlled vertical formatting, identical to the Series 100 printers.

In addition, the printer recognizes the following special control codes: bell, delete and elongated character, as described in Section 1.3.3.

### 1.3 PRINTER OPERATION

Basically, all printer functions can be grouped into one of the following three categories: 1) character printing, 2) paper movement, and 3) other auxiliary functions such as bell, delete, etc.

#### 1.3.1 CHARACTER PRINTING (Figures 1-3, 1-4)

A small aluminum carriage supports the print head assembly. During printing operation, the carriage travels along the print line from left to right. Printing is accomplished by selectively firing the print wires as the print head moves from left to right across the print line. Printing impulses energize the print solenoids and drive the print wires against the ribbon, paper and platen to form the characters in a dot matrix pattern. When the solenoids are de-energized, the wires are withdrawn so they are flush with the surface of the jewel. Each solenoid can fire independently up to five times for any one character. Figure 1-3 shows an example of the dot matrix forming the letter H. All character formation in the 5 x 7 and 9 x 7 dot matrix are shown in Series 300 Operators Manual.



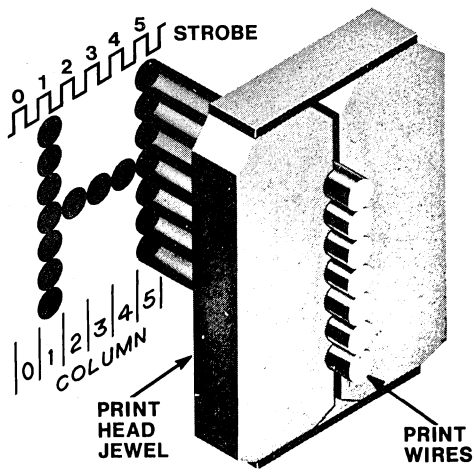

Figure 1-3. PRINTING THE LETTER (H)

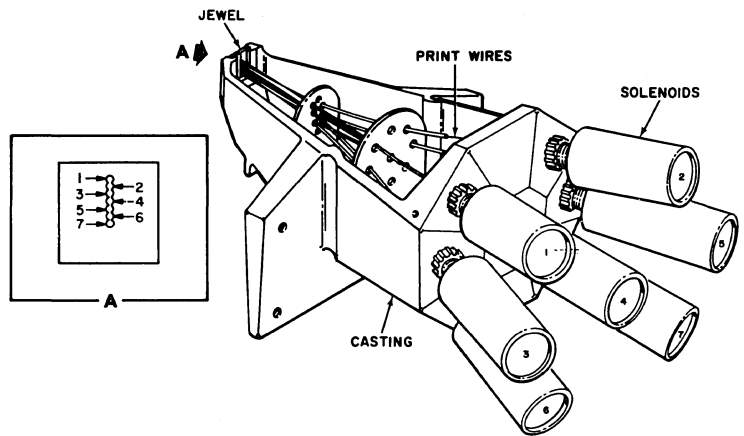

Figure 1-4. PRINT HEAD COMPONENTS

The print head (Figure 1-4) consists of the jewel, casting and seven solenoids with attached print wires. The seven print solenoids and their attached print wires are arranged radially around the print head. The free ends of the print wires pass through a wire guide at the front of the print head, which properly spaces the wires so that the correct wires pass through the correct hole in the print jewel.

Printing action is initiated when the input buffer has been filled or a carriage return (CR) code has been received. The print head then sweeps across the page until a CR command is decoded at the buffer output of the head reaches the 80-column limit switch. At this time, the print head returns to the left margin and an automatic line feed is performed. As an option, the automatic line feed can be disabled.

### 1.3.2 PAPER MOVEMENT (Figure 1-5)

Paper can be moved manually by rotating the platen knob or automatically by any of three paper movement commands: line feed, vertical tab and form feed.

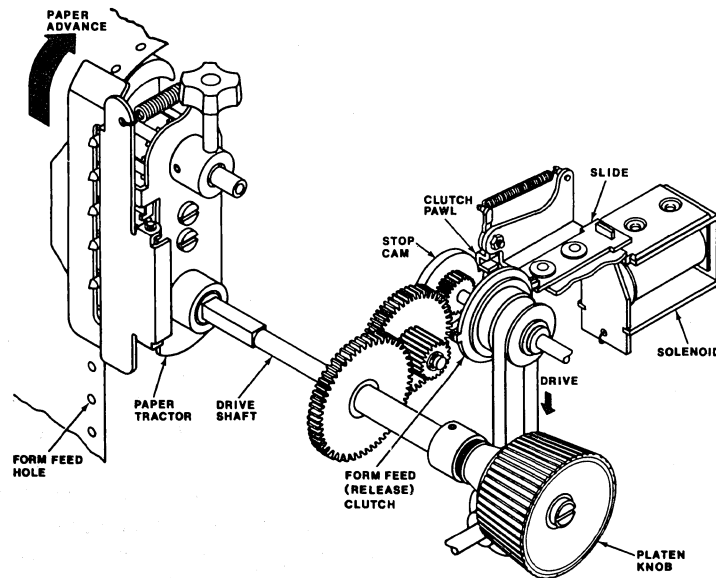

Figure 1-5. PAPER MOVEMENT MECHANISM

Power necessary to drive the sprocket-feed paper tractors controlling paper movement, is transmitted from the main motor through an O-ring belt to the form feed mechanism, where it is then transferred via the paper drive shaft to the paper tractors. The form feed mechanism consists of a form feed or release clutch, a line feed solenoid with slide unit, and a gear train mechanically linking the main motor to the paper feed tractors.

To initiate a single line feed, the line feed solenoid is energized 15 milliseconds. Upon completion of the line feed command, a 60-90 millisecond delayed line feed interval is generated. This allows the clutch pawl and clutch mechanism to return home before another line feed is allowed.

Vertical forms movement is accomplished by applying a DC level to the paper feed solenoid. In the standard 306 printer, this paper movement continues until it is either terminated by the reception of a delete code (octal 177) or an INPUT PRIME signal at the interface connector, or a paper time-out condition. However, if the optional Vertical Format Unit (VFU) is used, the paper movement is terminated when a hole is detected in the appropriate channel of the vertical format paper tape.

As paper moves in the printer, each line advance causes a line count switch located in the form feed mechanism to open and close. The two wires from this switch go to the interface connector via the logic card. As a result, a line count level from the input device is switched on and off by the printer for each line advance. If the 306 contains no optional VFU, the user's software can control vertical formatting by counting these line count pulses and terminating the paper movement operation when appropriate.

When the printer runs out of paper, a sensing switch activates a two-second audible tone in a speaker (option) located at the rear. The printer also stops printing and lights the PAPER EMPTY light on the control panel.

### 1.3.3 SPECIAL FUNCTIONS

In addition to the printable characters shown in Appendix B, and the carriage return, line feed, form feed, and vertical tab codes previously described, the printer also recognizes the following special control codes.

Delete (Octal 177) - Primes the printer electronics and clears the buffer.

Bell (Octal 007) - With Bell option only - Generates a two-second audible tone in the speaker at the front of the printer.

Select (Octal 021) - Allows printer to receive data, same as activating SELECT switch.

De-Select (Octal 023) - Inhibits printer from receiving data, same as deactivating SELECT switch.

Elongated Boldface Characters (Octal 016) - Prints elongated characters on a line-by-line basis (character-by-character controlled by bit 8, optional).

## 1.4 SYSTEM FEATURES

### 1.4.1 SPECIFICATIONS SUMMARY

The Model 306 printer contains all the features described in the previous sub-sections of this manual. Some of these features, in addition to a few characteristics not previously mentioned, are summarized in the following specifications.

<b>Printing Method</b>	Impact, character-by-character, one line at a time
<b>Printing Rate — Characters</b>	120 characters per second
— Full Lines	60 lines per minute (80 character line)
— Short Lines	150 lines per minute (20-30 characters)
<b>Transmission Rate — Serial</b>	100 to 9600 baud (with Serial option)
— Parallel	See Timing Diagram, Appendix B
<b>Data Input</b>	Parallel (Serial option available)
<b>Character Structure</b>	5 x 7 dot matrix, 10-point type equivalent 9 x 7 dot matrix, 10-point type equivalent (option)
<b>Code</b>	USASCII — 64 characters printed
<b>Indicator-Switch Controls</b>	ON/OFF, SELECT, FORMS OVERRIDE. Option. LINE FEED, TOP OF FORM
<b>Indicators</b>	PAPER OUT, SELECT
<b>Manual Controls</b>	Form Thickness, Paper Advance Knob
<b>Character Buffer</b>	80 characters (1 line)
<b>Format</b>	80 characters maximum per line, 6 lines per inch
<b>Paper Feed</b>	Sprocket feed, adjustable to 9 <sup>1</sup> / <sub>2</sub> " width
<b>Paper</b>	Standard sprocketed paper
<b>Number of Copies</b>	Original and up to four carbon copies
<b>Dimensions</b>	12 <sup>3</sup> / <sub>4</sub> " high, 18 <sup>3</sup> / <sub>4</sub> " deep, 23 <sup>1</sup> / <sub>4</sub> " wide
<b>Weight</b>	66 pounds
<b>Electrical Requirements</b>	115 VAC ±10%, 60 Hz. 115/230 VAC ±10%, 50 Hz (option)
<b>Temperature — Operating</b>	40° to 100°F
— Storage	—40° to 160°F
<b>Humidity — Operating</b>	5% to 90% (no condensation)
— Storage	0% to 95%

### B. RIBBON SPECIFICATIONS

The printer uses a 1-inch nylon ribbon mounted on 3-inch diameter spools. The following four colors are available:

- Black - Part No. 63002293-5001
- Red - Part No. 63002293-5002
- Green - Part No. 63002293-5003
- Blue - Part No. 63002293-5004



## C. PAPER SPECIFICATIONS

The printer uses continuous form paper with standard feed holes on each edge. Paper widths from 4 to 9½ inches can be accommodated by the printer. Using multiple-part form, one original and up to 4 copies can be printed, all very legible. Paper weight specifications are as follows:

Single-Part Forms:	15 to 20 lb
Multiple-Part Forms:	Original - 12 to 15 lb Copies - 9 to 12 lb, last copy 15 lb (Maximum of five parts)
Carbon Paper:	7¼ lb with medium hardness

### 1.4.2 STANDARD AND OPTIONAL FEATURES

#### standard features

- Parallel data input
- Elongated boldface characters (line-by-line)
- Paper runaway inhibit (10 second time out)
- Lower case prints as upper case
- Automatic line feed on carriage return
- Gated strobe pulse (data input)
- 115 Volts, 60 Hertz
- Prints original plus four copies
- Coded character software
- Fixed vertical/horizontal registration
- Low noise level
- 5 x 7 Dot matrix

#### optional features

- Vertical format control
- Automatic motor control
- Additional sets of 64, 96 or 128 characters
- 9 x 7 dot matrix character sets
- Audio alarm buzzer
- 50 Hertz, 230 Volts AC
- Line feed switch
- Non-gated strobe
- Automatic line feed disabled
- Selectable single character elongation
- Automatic carriage return on line feed, vertical tab and form feed
- Serial communication interfaces
- Popular parallel computer interfaces
- Bottom of form
- Inhibit delete code

### 1.5 PHYSICAL DESCRIPTION

The printer is approximately 12" high by 19" deep by 23" wide, and weighs approximately 66 pounds. The complete printer is assembled on a base made of cast aluminum. Enclosing the printer are three removable plastic covers: the main cover, top cover and VFU cover. The top cover can be opened to give access to the print head by tilting the cover back or lifting it completely off. The VFU cover can also be tilted back or removed for access to the optional Vertical Format Unit, if it is used.

Figures 1-6 to 1-9 are different photographic views of the printer taken with the covers removed. All major assemblies are identified, in addition to a few other important components, the locations of which should be noted.

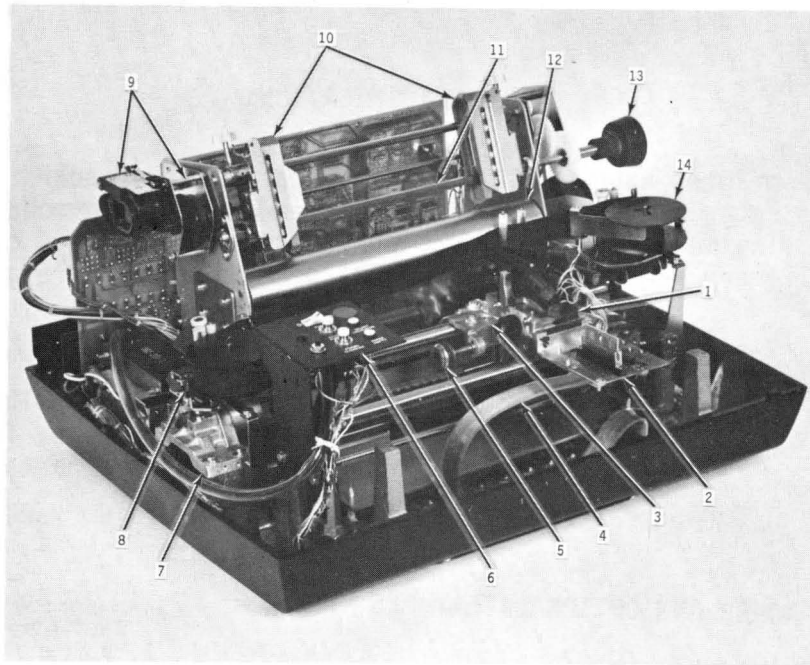

- |                                |                                |                         |
|--------------------------------|--------------------------------|-------------------------|
| 1. Print Head Assembly         | 5. Damper Piston               | 10. Pin Feed Mechanisms |
| 2. Video Ampl. and Cable Ass'y | 6. Operator Panel              | 11. Paper Feed Shaft    |
| 3. Carriage                    | 7. Damper Cylinder             | 12. Platen              |
| 4. Ribbon Cable                | 8. Left Ribbon Feed            | 13. Platen Knob         |
|                                | 9. Vertical Format Unit Option | 14. Right Ribbon Feed   |

Figure 1-6. LEFT FRONT VIEW OF 306

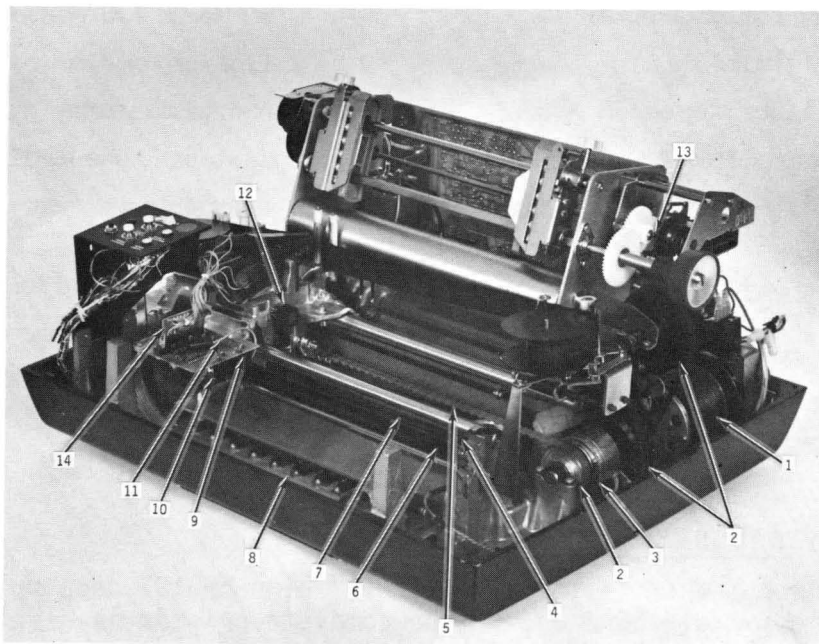

- |                      |                           |                              |
|----------------------|---------------------------|------------------------------|
| 1. Main Drive Motor  | 6. Timing Fence           | 11. Optic Bundle             |
| 2. Drive Mechanism   | 7. Carriage Return Spring | 12. Penetration Control Knob |
| 3. Forward Clutch    | 8. Power Driver Board     | 13. Form Feed Mechanism      |
| 4. Reed Switch (EOP) | 9. Optical Pick-Up        | 14. Solenoid Finger Board    |
| 5. Main Drive Belt   | 10. Light Source          |                              |

Figure 1-7. RIGHT FRONT VIEW OF 306

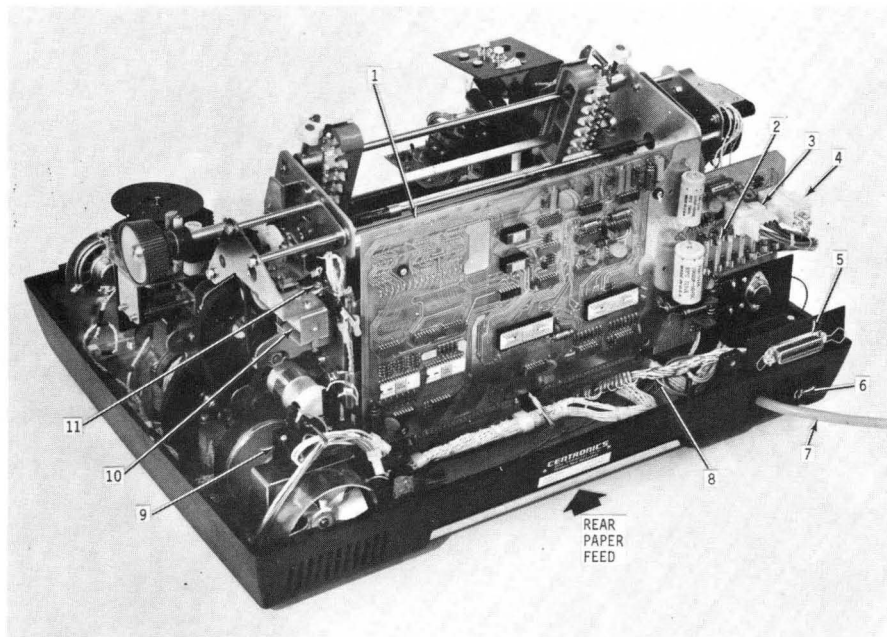

- |                                    |                         |
|------------------------------------|-------------------------|
| 1. Logic/Power Supply Board        | 7. AC Power Input       |
| 2. Logic/P.S. Fuses                | 8. Input Cable (W2)     |
| 3. AC and 35V Input Connector (J1) | 9. Motor Control Option |
| 4. DC Output Connector (J2)        | 10. Line Feed Solenoid  |
| 5. Input Connector                 | 11. Line Count Switch   |
| 6. In-Line Fuse                    |                         |

Figure 1-8. REAR VIEW OF 306

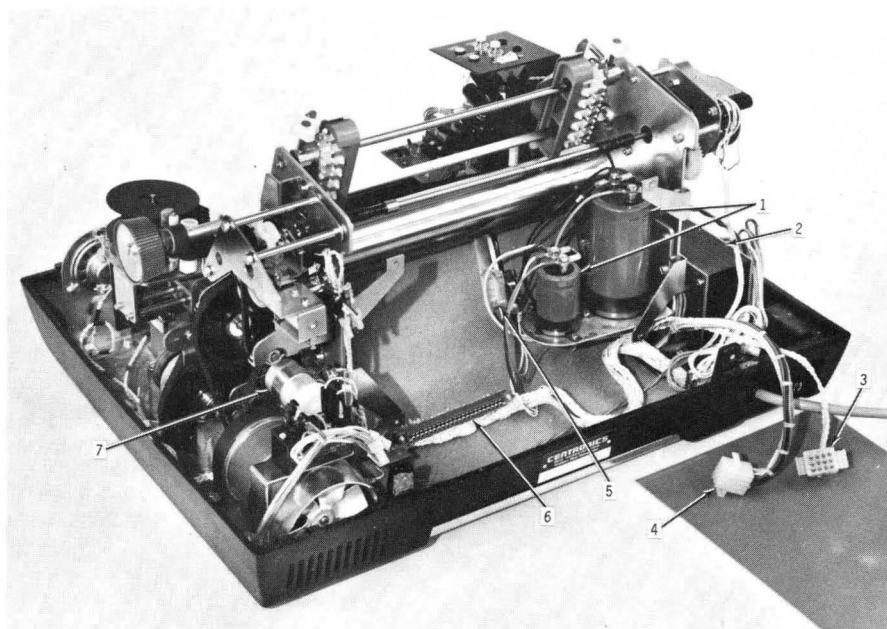

- |                                    |                             |
|------------------------------------|-----------------------------|
| 1. 35V Power Supply                | 5. Paper Out Switch         |
| 2. Power Transformer               | 6. Main Printer Harness     |
| 3. DC Output Connector (J2)        | 7. Motor Starting Capacitor |
| 4. AC and 35V Input Connector (J1) |                             |

Figure 1-9. REAR VIEW OF 306 (LOGIC/P.S. BOARD REMOVED)

SECTIONS 2 AND 3  
INSTALLATION AND OPERATION

A separate Series 300 Operators Manual contains most of the installation, set-up and operating procedures for the Model 306 printer. This Operators Manual should be referred to during normal printer installation and operation.

Included on the following pages is additional information not contained in the Operators Manual.

2.1 SITE PREPARATION (Figure 2-1)

A line drawing of the printer dimensions is shown in Figure 2-1.

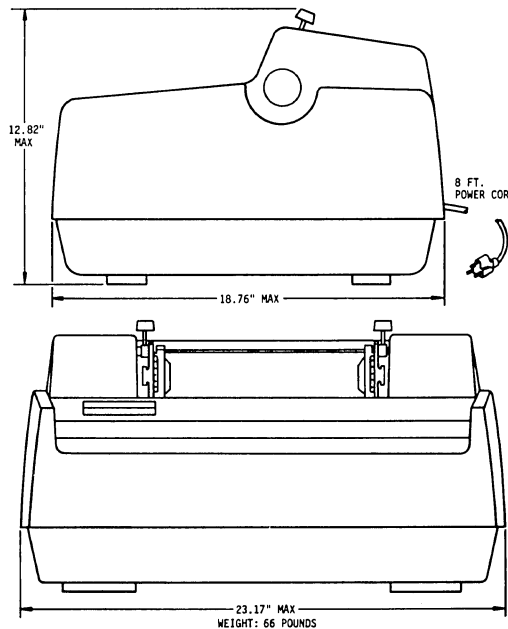

Figure 2-1. PRINTER DIMENSIONS

Environmental and electrical requirements at the installation site are as follows:

Temperature:	40 <sup>0</sup> to 100 <sup>0</sup> F (Operating) -40 <sup>0</sup> to 160 <sup>0</sup> F (Storage)
Humidity (% RH):	5% to 90% (no condensation) - Operating 0% to 95% - Storage
Electrical:	115 VAC $\pm$ 10%, 60 Hz, 3 amps 115/230 VAC $\pm$ 10%, 50 Hz, 3 amps

## 2.2 SHIPPING CRATE

The printer is shipped in a crate approximately 22 inches high, 27 inches deep and 28 inches wide. The crate is made of weatherized, triple-walled cardboard. When properly strapped, the packing crate and printer is capable of fork lift operation with a seven-high stacking capability.

Shipped with the printer are the following items:

- (1) If a special interface is used, the interface card is included with the printer. For certain interfaces such as the RS232, a special cable is also shipped. Cabling requirements for the standard parallel interface are defined in Appendix C.
- (2) If optional vertical format unit is installed a standard vertical format paper tape providing six line feeds (one inch) for each vertical tab and 66 lines (11 inches) for each form feed code is provided. Refer to the Operators Manual for duplicating the existing tape, or if a different format is desired, for generating a new tape.
- (3) Documentation - All documentation describing that particular printer is included in a plastic bag under the printer. This documentation includes a technical manual for the printer and any optional interface, and a notice of all approved changes incorporated in the printer but not documented in the manual. Please keep this documentation with the printer at all times so that accurate information will be available for troubleshooting purposes.
- (4) Pin Feed Knobs - These knobs are contained in a small plastic bag stapled to the guide bar for the pin feed unit.
- (5) Print Sample - A sample printout from that particular printer is included in the upper paper pane.
- (6) Unpacking/Repacking and Set-Up Instruction Sheet.



## SECTION 4 THEORY OF OPERATION

### 4.1 INTRODUCTION

This section on the theory of operation contains a detailed description of each major function performed by the Model 306 printer electronics. Figure 4-1 shows a basic functional diagram of the printer electronics.

Throughout this section, reference is made to the schematic diagrams contained in Section 7. The section is organized as follows:

- Paragraph 4.2 Basic Timing
- 4.3 Initializing the Printer (Prime, Select)
- 4.4 Data Input (Data, Strobe, Busy, Acknowledge)
- 4.5 Shift Register (Buffer)
- 4.6 Character Printing
- 4.7 Paper Movement (Line Feed, Vertical Tab, Form Feed)
- 4.8 Special Functions (Bell, Paper Empty, Delete, Motor Control)
- 4.9 Power Supplies
- 4.10 Outputs from LSI chips

### 4.2 BASIC TIMING

The basic timing clock for the printer electronics is derived from signal OSC. This OSC signal is generated on LSI chip ME16 pin 25. The frequency of OSC, determined by the RC circuit (R41-C9) on pin 26 of this chip, ranges from 100 to 200 KHz.

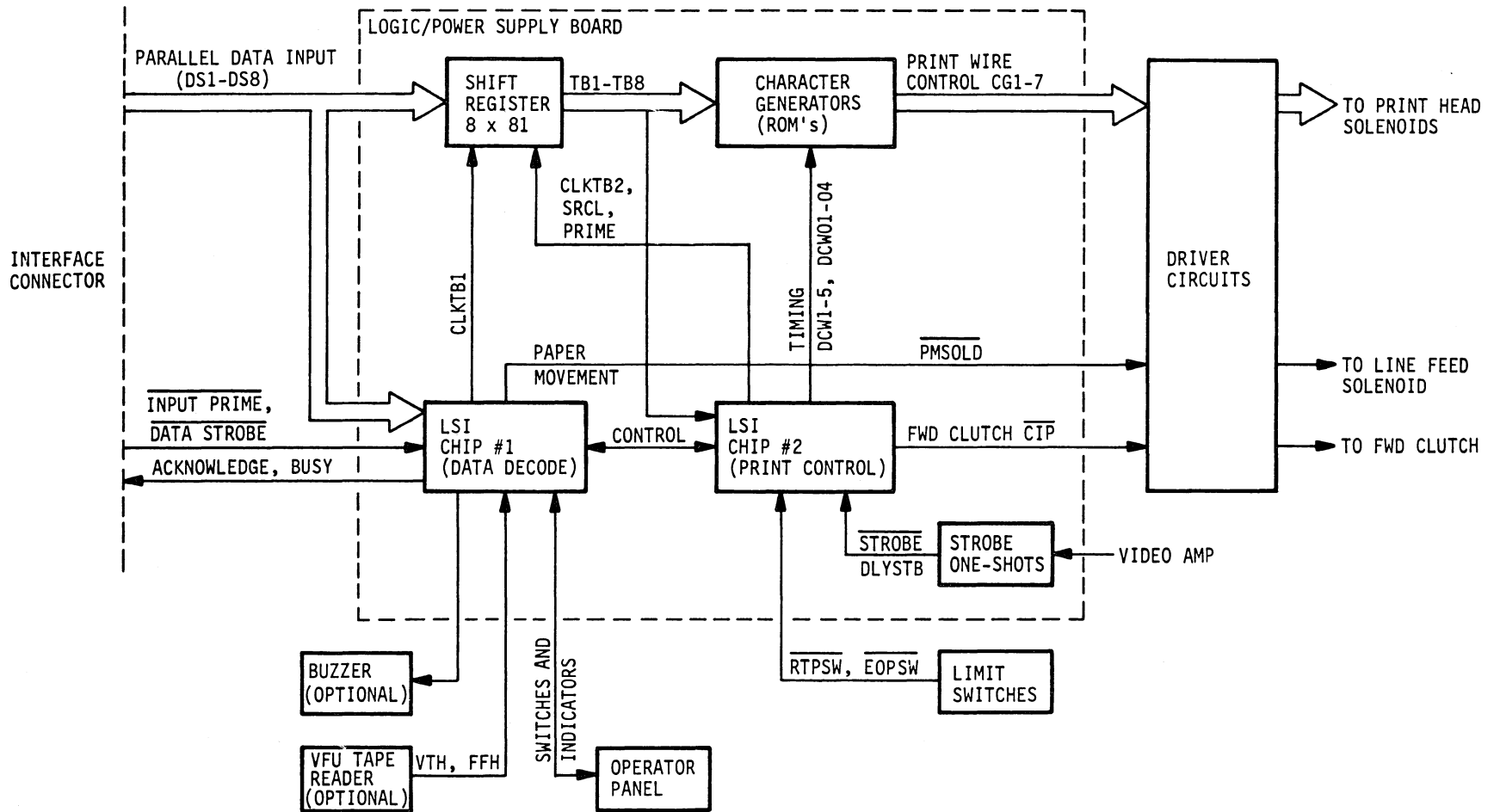

Figure 4-1. MODEL 306 BLOCK DIAGRAM

This OSC clock is then used by both LSI chips (ME16 and ME25) for internal timing, and is inverted by ME20-6 to generate OSCXT. Signal OSCXT goes to the printer interface connector and if an optional interface is used, it also goes to this optional interface board (e.g., RS232 Serial Interface).

### 4.3 INITIALIZING THE PRINTER

Before the printer can accept input data, it must first be PRIME'd and SELECT'ed. The prime operation initializes the printer logic to a ready state. The select operation after causing a prime condition, (which can be disabled by jumper E14-E15), resets the busy line to the interface connector and makes the printer ready to receive data.

#### 4.3.1 PRIME

The PRIME signal, generated on LSI chip ME16-37, is generated by any of the following conditions:

- a. Power Turn-on - When the printer is turned on, capacitor C10 is initially discharged causing a low 100-500 msec  $\overline{\text{PWRPRM}}$  signal into ME16-32. This generates a high PRIME signal at ME16-37. As C10 charges to +5V,  $\overline{\text{PWRPRM}}$  goes high terminating the power prime operation.
- b. Printer Selection - If the Delete Inhibit option (DELINH) is not used (i.e., jumper E13 to E14 is connected), then a low  $\overline{\text{SLCT}}$  input to ME16-40 and a high DELINH to ME16-39 generates a 100-400 usec PRIME pulse at ME16-37.
- c. End of a Printed Line - At the end of a line of print,  $\overline{\text{CIPX}}$  at ME16-30 goes high, turning off the forward clutch and generating a 100-400 usec PRIME pulse at LSI chip ME16-37.

- d. Delete Code - Receiving a delete code (octal 177)\* on input data lines  $\overline{DS1-DS7}$  generates a low  $\overline{DCPRM}$  output at LSI chip ME25-8. Signal  $\overline{DCPRM}$  then generates a 100-400 usec PRIME pulse out of LSI chip ME16-37.
- e. Input Prime - Reception of a low  $\overline{INPUT\ PRIME}$  level at the interface connector generates a high IP signal into LSI chip ME25-36. This produces a low  $\overline{DCPRM}$  output at LSI chip ME25-8 (same as the delete code), which in turn generates a 100-400 usec PRIME pulse out of LSI chip ME16-37.

In all of the above cases, the high PRIME signal out of LSI chip ME16-37 resets the printer logic including the shift register and places a dummy character in the first character position in the register. A timing diagram of the prime timing is shown in Figure 4-2.

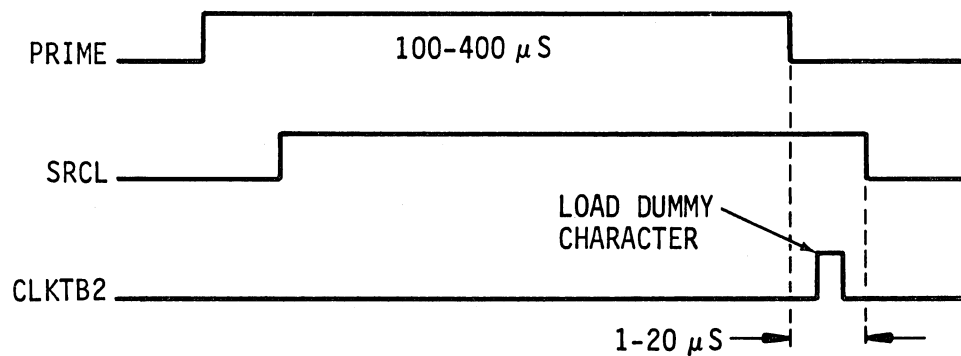

Figure 4-2. PRIME TIMING

\*Throughout this section, input codes are defined only by their first seven bits. However, bit 8 into the function decoder contained in LSI chip 25, must be a ONE.

The high PRIME signal into pin 3 of the two shift register elements (ME18 and ME19) disables all inputs to these elements and internally resets all stages of the shift register. When PRIME goes low, recirculate signal SRCL from LSI chip ME16-38 remains high and a single CLKTB2 pulse is generated at ME16-36. The high SRCL (and low PRIME) connects shift register outputs  $\overline{TB1-TB7}$  back to inputs  $\overline{DS1-DS7}$ , and enables a high (+5V) input to stage 8. Note that since the shift register uses inverted signals for both inputs and outputs (e.g.,  $\overline{DS1}$  and  $\overline{TB1}$ ), a high input to stage 8 represents a ZERO into that stage.

The single CLKTB2 pulse then clocks a dummy character into the register (i.e., ONES into stages 1-7 and a ZERO into stage 8).

#### 4.3.2 SELECT

Before the printer can receive data, it must first be selected. This can be done either by the SELECT switch on the operator panel or by an octal 021 code on the input data lines.

Pressing the SELECT switch (S2) generates a low SELSW signal into LSI chip ME25-31. The chip contains "anti-bounce" protection which requires the SELSW line to be noise-free for approximately 2-8 msec before the level is recognized by the chip. After this delay, the low SELSW input sets a Select latch in the chip. The output of this latch appears as signal SLCT' on LSI chip ME25-40.

Similarly, a decoded octal 021 code on data inputs  $\overline{DS1-DS7}$  ANDed with ungated data strobe pulse DSTA also sets this Select latch.

The printer is deselected (i.e., the internal Select latch is reset) either by again pressing the SELECT switch or by an octal 023 on data lines  $\overline{DS1-DS7}$  and a DSTA pulse. Alternately pressing the SELECT switch alternately selects and deselects the printer. Note that when power is turned on,  $\overline{PWRPRM}$  resets the internal Select latch so that the printer initially appears in a deselect state.

A high SLCT' signal at ME25-40 indicates that the printer is selected. This signal, inverted by ME22-6 ( $\overline{SLCT}$ ) turns on the SELECT lamp on the operator panel.  $\overline{SLCT}$  inverted by ME20-4 generates a SLCT signal to the interface connector.

If DELINH jumper E13 to E14 is connected, then selecting the printer will also cause a prime condition. If jumper E14 to E15 is used, select will not cause a prime condition.

#### 4.4 DATA INPUT

Inputs to the printer consist of seven standard parallel data lines (DATA1-DATA7), an optional DATA8 line, an active low DATA STROBE input, and an active low INPUT PRIME line. The first seven data lines represent the 7 bit USASCII code shown in Series 300 Operators Manual. The optional eighth bit is used as a control bit either for specifying an elongated character or for selecting an additional character set. The data strobe is used to synchronize the input data with the printer electronics. The prime line is used to prime (initialize) the printer electronics.

The eight data inputs have a unity loading factor and are terminated by a 1K pull-up resistor to +5 volts. The data strobe and prime inputs are terminated by a 470 ohm resistor to +5 volts. Note that with no input on DATA8 line, terminating resistor R15 holds the input at +5V, making bit 8 appear as a ONE on the logic card.

In response to received data, the printer generates an Acknowledge pulse to acknowledge reception of a character. If the received character caused the printer to perform some function such as paper movement, character printing, etc., the printer responds with a Busy signal.

##### 4.4.1 DATA INPUT TIMING

In general, the data transfer sequence consists of the input device placing the appropriate code on the data lines to the printer and then generating a data strobe pulse. The printer, after a slight delay, responds with an acknowledge pulse. Or if the received data caused a busy condition, the printer first activates the busy line for the duration of the busy condition and then responds with an acknowledge pulse.

#### 4.4.1.1 Normal Data Input - No Busy

The diagram in Figure 4-3 shows the timing involved in transferring data, which does not cause a busy condition.

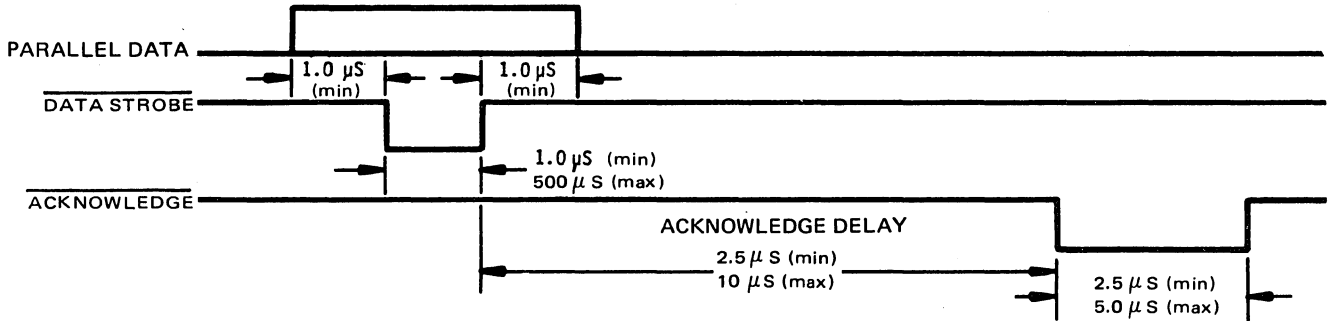
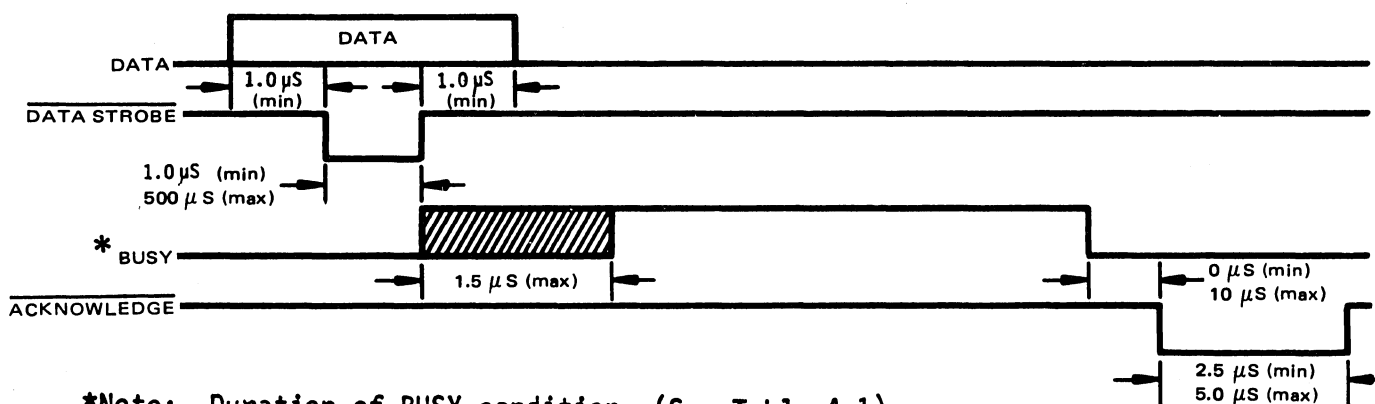

Figure 4-3. INPUT DATA TIMING - NO BUSY CONDITION

As shown in the diagram, each data line must be stable at least 1.0 usec before and after DATA STROBE, and the DATA STROBE pulse must be at least 1.0 usec wide. In response to the received data, some 2.5 to 10 usec after the trailing edge of DATA STROBE, the printer generates a 2.5 to 5.0 usec ACKNOWLEDGE pulse indicating that it is ready to receive additional data. As a standard feature, the 306 will not recognize a data strobe during the acknowledge delay interval. As an option, however, a non-gated data strobe is available.

#### 4.4.1.2 Data Input Causing Busy

The diagram in Figure 4-4 shows the interface timing involved receiving any character which causes a busy condition in the printer. (Note that a Bell code does not cause a busy condition).



\*Note: Duration of BUSY condition (See Table 4-1)

Figure 4-4. INPUT DATA TIMING - CAUSING BUSY CONDITION

As shown in the diagram, the printer responds to any of the characters in Table 4-1 by generating a BUSY signal from 0 to 1.5 usec after the trailing edge of DATA STROBE. As shown in Table 4-1, the duration of busy depends on the specific function being performed.

From 0 to 10 usec after BUSY is terminated, the printer generates a 2.5 to 5.0 usec ACKNOWLEDGE pulse, to indicate that the specified function is completed.

Table 4-1

Any printable character (except 80th character on a line).	No Busy
Line Feed	75-105 msec
Vertical Tab (1 inch)	300-310 msec (with optional VFU)
Form Feed (11 inches)	3-3.5 sec (with optional VFU)
Delete	100-400 usec
Bell	No Busy
Select	100-400 usec
Deselect	Until printer is selected
Print (CR or last character)	8.4 msec per character plus 75-105 msec line feed. Printer is not busy during return time (270 msec max.).



#### 4.4.2 BUSY

A busy indication is developed by LSI chip ME25 pin 11. This  $\overline{\text{BUSY}}$  output, normally high when the printer is not busy, goes low when any of the following conditions occurs:

- (1)  $\overline{\text{CSBSY}}$  goes low - This occurs when a dummy character ( $\overline{\text{TB8}}$ ) is detected at the shift register output and a prime operation is not in progress. This indicates that the 80th character has just been loaded into the shift register (without a carriage return code).
- (2) PRIME goes high - This occurs during a prime operation as described in Section 4.3.1.
- (3) LFF (internal to ME25) goes high - This occurs either when a form feed code (octal 014) is received, or if the optional TOP OF FORM switch on the operator panel is pressed. (Note: If the DSC option is used, the received FF code will first cause the line to be printed before activating LFF). LFF is normally reset by the trailing edge of DLYLF.
- (4) LLF (internal to ME25) goes high - This occurs when a line feed code (octal 012) is received or the optional LINE FEED switch on the operator panel is pressed. LLF is reset by the trailing edge of DLYLF.
- (5) LTF (internal to ME25) goes high - (Similar to the LFF signal) - LTF goes high when a vertical tab code (octal 013) is received and is reset by the trailing edge of DLYLF.
- (6)  $\overline{\text{DCPRM}}$  goes low - This occurs: (a) when a delete code (octal 177) is received, or (b) when an  $\overline{\text{INPUT PRIME}}$  signal is received at the interface connector, or (c) a power prime ( $\overline{\text{PWRPRM}}$ ) condition exists.
- (7) REMCR (internal to ME25) goes high - This occurs when a control character is clocked into the shift register, indicating the start of a character printing operation. In the standard 306 printer, only the carriage return control code (octal 015) is stored in the shift register.

However, if the DSC option is used (jumper E10 to E11), then a LF, VT, FF, or CR code (octal 012, 013, 014, and 015 respectively) may be loaded into the shift register.

- (8)  $\overline{\text{PMSOL}}$  goes low - This occurs while the paper movement solenoid is activated.
- (9) FAULT goes high - This occurs: (a) if the printer is de-selected ( $\overline{\text{SLCT}}$  is low), or (b) if the printer is out of paper ( $\overline{\text{PE}}$  is low), or (c) during a paper time-out condition, or (d) during a Light Detect ( $\overline{\text{LD}}$ ) error condition.  $\overline{\text{LD}}$  goes low if no video signal is detected as the print head travels across the page.
- (10) DLYLF goes high - This 60-90 millisecond line feed delay occurs following a paper movement operation.

As shown in the timing diagram in Figure 4-4, BUSY can occur up to 1.5 usec following the trailing edge of  $\overline{\text{DATA STROBE}}$ . The worst case (1.5 usec) condition arises when  $\overline{\text{CSBSY}}$  goes active. This occurs because of the accumulated delays in loading the 80th character in the shift register, detecting the dummy character at the output, generating the  $\overline{\text{CSBSY}}$  on LSI chips ME16 and finally generating the  $\overline{\text{BUSY}}$  on LSI chip ME25.

#### 4.4.3 FUNCTION DECODER

The buffered data inputs are applied to a function decoder on LSI chip ME25. These data lines gated with a data strobe signal are decoded and if a control code is detected, the following actions occur:

Function	Octal Code	Jumpers	Strobe	Output Mnemonic	Printer Action
Bell (optional)	007	None	Gated	BELL	Generates an audible tone, 1 to 2 seconds in duration, in the speaker at the front of the printer.

Function	Octal Code	Jumpers	Strobe	Output Mnemonic	Printer Action
Line Feed*	012	None	Gated	$\overline{\text{CSLF}}$ , $\overline{\text{PMSOL}}$	Advances the paper one line.
Vertical Tab*	013	None	Gated	$\overline{\text{PMSOL}}$	Causes paper to advance. If the optional Vertical Format Unit is used, paper advances until the next hole in channel 5 of the paper tape is reached.
Form Feed*	014	None	Gated	$\overline{\text{PMSOL}}$	Causes paper to advance. If the optional Vertical Format Unit is used, paper advances until the next hole in channel 7 of the paper tape is reached.
Carriage Return	015	None	Gated	$\overline{\text{DSCR}}$	Causes the received line of characters to be printed.
Elongated Character	016	E16-E18 E20-E23	Gated	$\overline{\text{UPSC}}$	Causes <u>all</u> characters on the line to be printed at double the normal width.
Select	021	None	Ungated	SLCT'	Selects the printer. E14 to E15 inhibits a prime operation during select.
Deselect	023	None	Ungated	SLCT'	Deselects the printer.
Delete	177	None	Ungated	$\overline{\text{DCPRM}}$	Primes the printer.

\*If the DSC option is used (jumper E10 to E11), LF, VT, and FF also cause the received line of characters to be printed.

In addition to the functions listed above, the function decoder also monitors the input data for the first printable character (i.e., a ONE in bit 6 or 7). Detection of the first printable character, sets First Character Clock latch (FCCLK) internal to LSI chip ME25. Only when this latch is set will the printer respond to a carriage return code (or if the DSC option is used, to a LF, VT, or FF code) by printing the line of characters.

#### 4.5 SHIFT REGISTER (BUFFER)

The printer storage buffer consists of two quad 81-bit shift register MOS elements (ME18 and ME19). These elements provide an 8 x 81-bit storage capacity or one full line of 80 characters. The extra character storage (i.e., 81 instead of 80) is used for storing a dummy character (a ONE in bit 8). Detection of this dummy character at the shift register output indicates that the 80th character for that line has just been shifted into memory.

A high PRIME input to ME18 and ME19, disables all other inputs and asynchronously resets the entire register. When PRIME is low, the shift register operates in either the normal or the recirculate mode. With the Recirculate input (SRCL) low, each CLKTB1 or CLKTB2 pulse clocks the  $\overline{DS1}$ - $\overline{DS8}$  inputs into the shift register. With SRCL high, the register is in the recirculate mode. The first three stages in each shift register element are recirculated internally. The fourth stage in ME19 is recirculated by the external connection of  $\overline{TB4}$  to the Recirculate Input (R.I.). The R.I. terminal for the fourth stage in ME18, however, is tied to +5V. As a result, when the SRCL input is high, CLKTB recirculates the  $\overline{TB1}$ - $\overline{TB7}$  outputs back to the inputs and forces a ONE into the eighth stage ( $\overline{TB8}$ ).

The actual shift register timing depends on which of the following printer operations is taking place: 1) a prime condition; 2) data reception 3) reception of a carriage return code (octal 015) prior to the 80th character in a line; or 4) printing a line of characters.

##### (1) Priming the Shift Register

During a prime condition, LSI element ME16 generates a high PRIME signal. While PRIME is high, all shift register stages are automatically reset, independent of the data inputs. After PRIME goes low, SRCL remains high and a single CLKTB1 pulse is generated. At this time, a ONE is clocked into bit 8 (due to +5V at the recirculate input ME18 pin 15), generating a dummy character at that location.

(2) Normal Data Input

During normal data input from the external device, LSI element ME25 generates a CLKTB1 pulse, slightly delayed from data strobe, each time a printable character or a CR code has been received. The trailing edge of CLKTB1 then clocks data lines  $\overline{DS1}-\overline{DS8}$  into the shift register.

(3) Following a Carriage Return Code

Following the reception of a carriage return code, LSI chip ME16 generates CLKTB2 pulses to the shift register, at the same rate as the OSC clock. This shifts the register until the dummy character appears at the output ( $\overline{TB8}$  goes high). The high  $\overline{TB8}$  then terminates the CLKTB2 pulses.

(4) During Character Printing

When printing a line of characters, during each DCWO interval (developed internally in LSI chip ME16), the video STROBE pulse generates a CLKTB2 pulse. This clocks the next consecutive character to the output of the shift register, where it remains until the next DCWO-STROBE interval.

## 4.6 CHARACTER PRINTING

When the dummy character appears at the shift register output ( $\overline{TB8}$ ), other than during a prime condition, the logic activates an electromechanical clutch which causes the print head to move from left to right across the page.

As the print head carriage moves across the page, the timing fence (and light source) generate timing inputs to the video amplifier board. These timing signals are used by the logic to register the five full columns of dots in the printed character.

Depending on whether a 5 x 7 or 9 x 7 character matrix is used for character generation, the logic uses either one or two ROM (Read-Only Memory) elements for each character set. One ROM defines the dot pattern for the five full-step columns, the other defines the dot pattern for the four half-step columns in a 9 x 7 matrix.

This section describes the character printing operation in the following sequence.

- Paragraph 4.6.1 Initiating the Printing Operation
- 4.6.2 Character Registration and Timing
- 4.6.3 Character Generator (ROM)
- 4.6.4 Print Head Operation
- 4.6.5 Power Driver Circuits

### 4.6.1 INITIATING THE PRINTING OPERATION

As data is received by the printer, the dummy character is shifted through the shift register. As the 80th character is received, the dummy character appears at the shift register output. If a carriage return code (octal 015) is received before the 80th character, this code is stored in the register and LSI chip ME16 generates CLKTB2 pulses to shift the register until the dummy character appears at the output. A high  $\overline{TB8}$  indicates dummy character.

When  $\overline{TB8}$  goes high, LSI chip ME16 generates a low  $\overline{CIPX}$  signal.  $\overline{CIPX}$  is inverted by ME21-10 to generate CIP, which is in turn inverted by ME21-8 to generate  $\overline{CIPM}$ . If the motor control option is not being used,  $\overline{CIPM}$  is jumpered from ME26 pin 2 to ME26 pin 11, and becomes signal  $\overline{CIP}$  (See Figure 4-5).

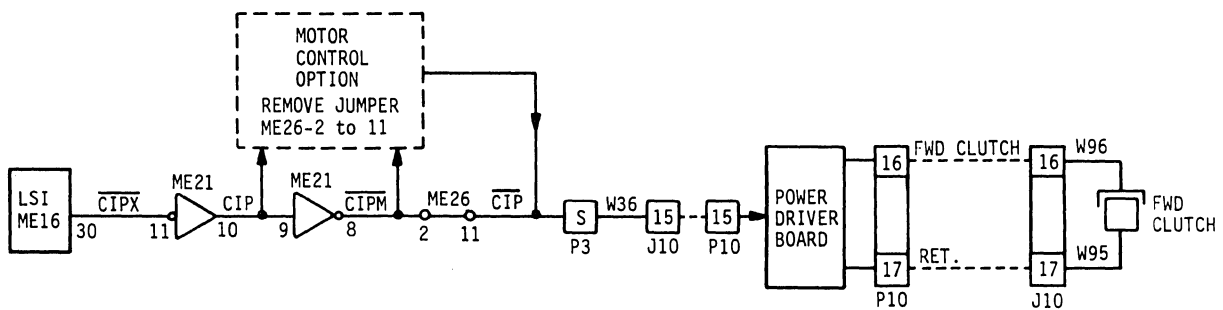

Figure 4-5. FORWARD CLUTCH INTERCONNECTION DIAGRAM

A description of the optional motor control unit is contained in Section 4.8.4.

The low  $\overline{CIP}$  signal controls a driver circuit on the power driver board, the output of which activates the forward clutch.

A limit switch is located at the right and left end of the printer. These switches (RTP switch on the left, EOP switch on the right) are activated by a magnet mounted on the underside of the carriage mechanism. Actuation of the RTP switch indicates the carriage is at its leftmost position. Actuation of the EOP switch indicates the carriage is at its rightmost position. The output of these two switches are applied to LSI chip ME16 where they are used to control the forward clutch logic ( $\overline{CIPX}$ ) and to detect failures in the video signal from the timing fence ( $\overline{LD}$ ).

When the EOP switch is activated or when a control character is detected at the shift register output,  $\overline{CIPX}$  goes high, turning off the forward clutch and returning the print head to the left margin.

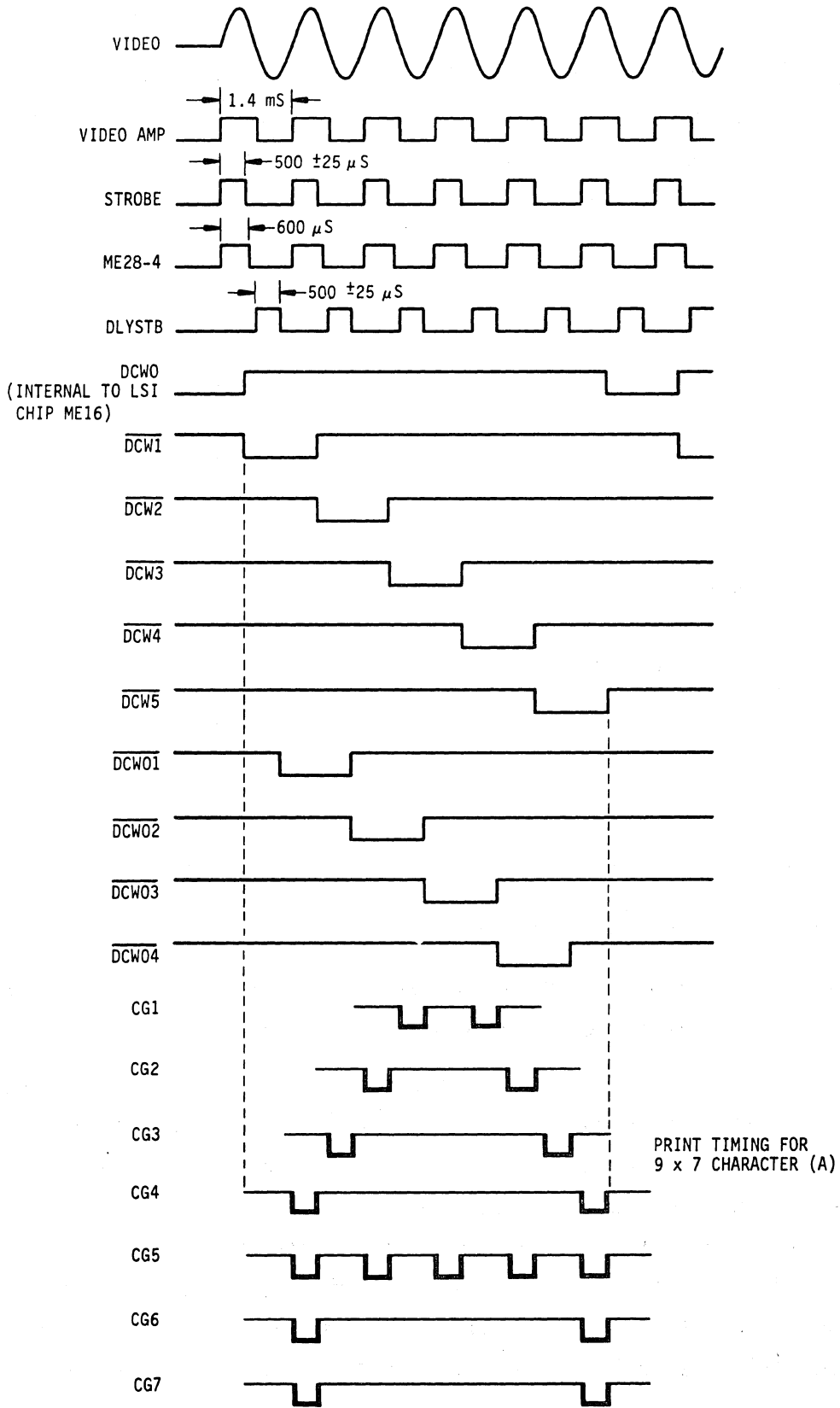

Figure 4-6. CHARACTER TIMING



#### 4.6.2 CHARACTER REGISTRATION AND TIMING

As the carriage moves, the optical pick-up head and light source on the video amplifier assembly generates the video signal for controlling the print timing. As the print head and optical head assembly moves across the timing fence, the vertical slots on the timing fence interrupt light to the optical pick-up head, generating a video signal. The VIDEO AMP output then triggers the STROBE one-shot ME23 on the logic card, initiating the print timing shown in Figure 4-6.

The STROBE one shot is adjusted for 475-525 usec. If a 9 x 7 matrix is used, the leading edge of STROBE also triggers a delay one-shot (ME28-4) adjusted for a 600 usec output pulse. The trailing edge of this pulse triggers the Delayed Strobe (DLYSTB) one-shot which is adjusted to the same pulse width as STROBE. In normal character printing, STROBE is used for full-step timing and DLYSTB for the half-step timing.

##### 4.6.2.1 Video Amplifier

The circuit used to amplify the video signal generated by the timing fence is located on the video amplifier assembly board, contained on the print head carriage.

The video amplifier consists of a high gain amplifier with positive feedback. When the photo cell is dark, no current flows through it and the base of Q2 is held at +5 volts through resistor R1. When Q1 is turned off, Q2 is turned on through resistors R2 and R7. Q2 being on also turns on Q3 through resistor R4.

Because Q3 is on, the collector is held at approximately ground, thereby allowing the current to flow through R7 and holding Q2 on through the positive feedback. When the photo transistor detects light, current is allowed to flow through it, thereby drawing current through transistor Q1 and resistor R2. Q1 then turns on and turns transistor Q2 off by shunting the current away from the base of Q2. When Q2 turns off, Q3 also turns off and the collector of Q3 is held to +5 volts through R6. R7 serves to drive Q2 further into the cut-off region. Capacitors C1 and C2 are used for proper frequency response and noise suppression. Resistor R3 is used to prevent leakage by keeping Q2 from turning off.

#### 4.6.2.2 Timing Signals

For normal character printing, five consecutive STROBE inputs to LSI chip ME16, generate timing outputs  $\overline{DCW1-DCW5}$  as shown in Figure 4-6. These timing intervals correspond to the five full-step columns in the character matrix. The quiescent state of this strobe counter is DCW0 (internal to the chip) which corresponds to the space interval between characters. During DCW0, the STROBE input generates a CLKTB2 pulse which clocks the next character to the output of the shift register. The  $\overline{DCW1-DCW5}$  timing outputs are used to address the appropriate column in the "full-step" ROM (character generator).

If a 9 x 7 character matrix is used, during each video interval both a STROBE pulse and a DLYSTB pulse of the same width is generated as shown in Figure 4-6. During normal character printing, four consecutive DLYSTB inputs to LSI chip ME16, generate timing outputs  $\overline{DCW01-DCW04}$ . These four timing intervals correspond to the four additional ("half-step") columns in a 9 x 7 matrix. Timing signals ( $\overline{DCW01-DCW04}$ ) are used to address the appropriate column in the "half-step" ROM (character generator).

During elongated character printing, the UCC latch (internal to LSI chip ME16) allows alternate STROBE pulses to clock the internal strobe counter and alternate DLYSTB pulses to clock the delayed strobe counter. As a result, timing outputs  $\overline{DCW1-DCW5}$  and  $\overline{DCW01-DCW04}$  are twice as long during elongated character mode than during normal character mode.

During the space interval between character (DCW0), timing signals  $\overline{DCW1-5}$  and  $\overline{DCW01-04}$  are all reset.

#### 4.6.3 CHARACTER GENERATOR (ROM)

The logic board can contain up to four ROM elements, depending on the selected character generating capabilities of that printer.

- (1) 5 x 7, 64-Character Set - ME2 only or ME4 only.
- (2) 9 x 7, 64-Character Set - ME2 and ME8 only, or ME4 and ME10 only.

- (3) 9 x 7, 64-Character Set and 5 x 7, 64-Character Set - ME2, ME8 and ME4.
- (4) 9 x 7, 96-Character set - ME2, ME8, ME4 and ME10.

Each ROM (Character Generator) element has three inputs (in addition to the input voltages):

- (1) The modified character code - Outputs  $\overline{TB1}$ - $\overline{TB5}$  from the shift register are buffered and applied to five of the six character inputs to all ROM's. For the ROM's in element locations ME2 and ME8, the sixth character code input is controlled by  $\overline{TB6}$ . For the ROM's in locations ME4 and ME10, the sixth character code input is controlled by CHADD7. By jumper option, CHADD7 can be  $\overline{TB6}$  or TB7.
- (2) Column Address - Timing outputs  $\overline{DCW1}$ - $\overline{DCW5}$  from LSI chip ME16, specify the five "full-step" columns in each 5 x 7 or 9 x 7 character matrix in ROM's ME2 and ME7. Timing output  $\overline{DCW01}$ - $\overline{DCW04}$  specify the four "half-step" columns in each 9 x 7 matrix in ROM's ME8 and ME10.
- (3) Timing - A low input to pin 28 of each ROM gates the 7-bit dot configuration of the addressed character and column to the output of that ROM. For the full-step ROM's (ME2 and ME4), this timing input is STROBE ANDed with ROMTB8 or  $\overline{ROMTB8}$ . By jumper option, ROMTB8 can be  $\pm 0V$ , +5V, TB7, TB8 or  $\overline{TB8}$ , allowing the selected one of these inputs to enable the ROM. The STROBE pulse provides the timing input for gating the 7-bit dot pattern to the print head solenoids.

For the half-step ROM's (ME8 and ME10), the timing input is ROME2 ANDed with ROMTB8 or  $\overline{ROMTB8}$ . For normal character printing, ROME2 generated by LSI chip ME16, is coincident with Delayed Strobe signal DLYSTB. This effectively interleaves the dot pattern from the half-step ROM's with the dot pattern from the full-step ROM's.

For elongated character printing, ROME2 is coincident with the STROBE signal. This combined with the fact that the DCW timing signals from LSI chip ME16 are twice as long during elongated character mode, causes the printed character to be twice as wide as normal characters. An example of the character (Y), both in normal and elongated style, is shown in Figure 4-7.

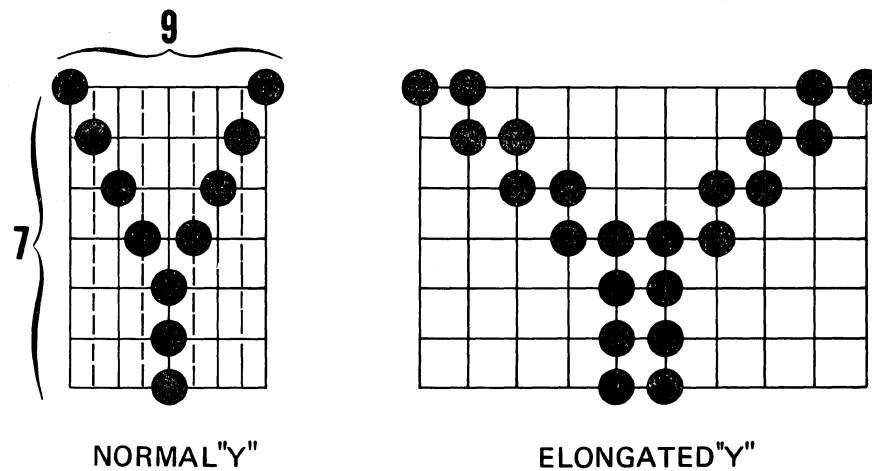

Figure 4-7. NORMAL AND ELONGATED CHARACTERS

The seven outputs from all four ROM's are wire ORed together and gated out to the Power Driver board as signals  $\overline{CG1}-\overline{CG7}$ . In normal operation, the STROBE or DLYSTB signal gates the addressed dot column to the Power Driver board. The input to ME7 pins 1 and 2 is normally low holding the output constantly high, enabling the output CG gates. If, however, there is a failure in the -12V supply, then ME7-1 and 2 goes high forcing ME7-3 low disabling the CG gates.

Note, the optional buffers and diodes (shown on the schematic) associated with the ROM elements are needed only if a +12V ROM is used. If only +5V ROM's are used, these additional buffers and diodes are not needed.

#### 4.6.4 PRINT HEAD OPERATION

The print head is the device used to do the impact printing of the characters. The head contains seven solenoids that move the tungsten wires against the ribbon to form the column of dots on the paper. The position of these solenoids and the location of the tungsten wires in the head are shown in Section 1. Solenoid #1 controls the top dot and solenoid #7 controls the bottom dot in a column. The wires come from each solenoid and are positioned at a jewel located at the end of the head. The length of these wires is approximately 3.5 inches and each wire requires about one ounce of force to begin its movement. The amount of force needed to move the wires 0.015 inch (i.e., the distance necessary to make a dot on the paper) is about 12 ounces.

The total distance travelled by the wires is approximately 0.015-inch, but under normal operation, the end of the head is about 0.006 inch from the ribbon and paper. The reason for locating the wires closer than 0.015 inch from the paper, is to account for the amount of force absorbed by the ribbon and paper upon impact.

The electrical timing and mechanical movement of the wires is shown in Figure 4-8. As shown, a 475-525 microsecond pulse is used to complete the impact. The voltage used to drive the solenoids is +35 volts unregulated. This voltage is about +35 to +38 volts when the pins are in an idle state, but drops to about +30 volts when all pins are engaged at the same time. From the beginning of the 475-525 microsecond drive pulse, about 200 microseconds is required before the wire starts to move in each solenoid. Once the wire starts moving, an additional 300 microseconds is required before the wire makes an impact on the paper. Approximately 500 microseconds more are required for the wire to retract to its normal position.

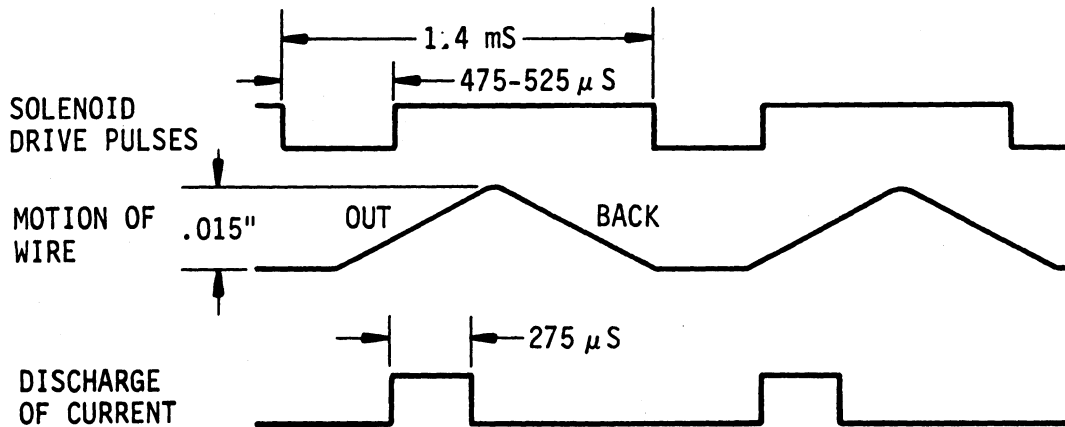

Figure 4-8. PRINT HEAD TIMING

#### 4.6.5 POWER DRIVER CIRCUITS

##### 4.6.5.1 Solenoid Drivers

The wire ORed outputs from the character generator  $\overline{CG1-CG7}$  are applied to the solenoid power driver circuits where they are inverted, amplified and used to generate current pulses for firing the solenoid in each head.

Since all solenoid driver circuits are identical and operate in the same manner, only the first one, consisting of inverter ME1 (pins 5 and 6) and Q1 will be described.

When  $\overline{CG1}$  is high, which is the normal inactive condition, the output of ME2 pin 6 is at  $\pm 0V$  and no current flows into the base of Q2. When  $\overline{CG1}$  goes low, ME2 pin 6 goes high and current flows through R1 into the base of Q1, turning Q1 on. Since the other side of the solenoid (LIA) is connected to +35 volts, current flows through the solenoid to the collector of Q2. Resistor R4 limits the solenoid current (collector current) to approximately 2.5 amps, which is required to fire the solenoid.

When  $\overline{CG1}$  goes back high, Q2 again turns off. The current flowing through the solenoid then passes through diode CR2 and into capacitor C1. C1 acts as a parallel resonant circuit with the inductance of the solenoid. R5 serves as a discharge path for capacitor C1.

#### 4.6.5.2 Forward Clutch

Power for moving the print head from left to right across the page is transmitted from the main drive motor to an electromechanical clutch mechanism. The clutch is controlled by a low  $\overline{CIP}$  signal from the logic board. This signal is applied to a driver circuit on the Power Driver card, the output of which activates the clutch.

The forward clutch driver circuit is very similar to the solenoid driver circuit described in Section 4.6.5.1. A low  $\overline{CIP}$  input causes the output of ME1 pin 8 to go high, turning on Q5. This generates a current pulse to the forward clutch, activating the clutch. Resistor R24 limits the current amplitude. When  $\overline{CIP}$  goes high, Q8 turns off, and current through the clutch decays through R23 and CR16.

#### 4.6.5.3 Clamp Circuit

The CLAMP diodes connected to the bases of the input driver transistors Q2 and Q7, have their cathodes tied together and connected to the collector of transistor Q19 in the clamp circuit.

When the printer is on, +5 volts on the base of Q19 and +4.7 volts on the emitter (developed by Zener diode CR21) holds Q18 off. With Q18 off, Q19 is also held off. Current flows through R49 and Zener diode CR22, thus providing a CLAMP voltage of +4.7 volts to the diodes. This back-biases the diodes so that they have no affect on the driver circuits.

As power to the printer is turned off, the +5 volts turns off before the +35 volts. This forward-biases Q18, turning it on, which then turns on Q19. The CLAMP signal then goes to ground, causing the bases of all drivers circuits to be tied to ground through the CLAMP diodes. This prevents any of the driver circuits from activating during power turn off.

### 4.7 PAPER MOVEMENT

Three separate printer functions can cause a paper movement operation: line feed, form feed, and vertical tab. Each of these functions cause the paper to move by activating the Paper Movement Solenoid ( $\overline{PMSOL}$ ), which in turn activates a clutch that mechanically links the main drive motor to the paper-feed tractors.

For each line feed operation, the solenoid is energized 15 milliseconds for single line feeds and approximately 50 milliseconds for the double line feed option. At the end of this interval, a 60-90 millisecond line feed delay is generated to allow the clutch pawl and clutch mechanism to return home before another paper movement operation is allowed.

In response to a form feed or vertical tab command, a dc level is applied to the solenoid, allowing continuous movement of the paper. In the standard 306 printer, this paper movement continues until it is either terminated by the reception of a delete code (octal 177) or an INPUT PRIME signal at the interface connector, or a paper time-out condition. However, if the optional Vertical Format Unit (VFU) is used, the paper movement is terminated when a hole is detected in the appropriate channel of the vertical format paper tape. The operation of the VFU is described in Section 4.7.4.

To prevent the printer from "hanging up" in a paper movement condition which would waste both time and paper, LSI chip 25 contains a paper time-out circuit. This circuit is activated by any paper movement command. In the standard 306 printer, the Paper Time-Out (PMTO) interval is factory-adjusted for approximately 6-9 seconds. If, at the end of this time, paper is still advancing, the line feed solenoid command (PMSOL) is immediately deactivated, terminating the paper movement operation.

As an option, this time-out interval can be adjusted from 2 to 12 seconds via R38 which controls the Low-Frequency Oscillator (LFOC) input to LSI chip ME25.

As paper moves in the printer, each line advance causes a line count switch located in the form feed mechanism to open and close. The two wires from this switch go to the interface connector via the logic card. As a result, a line count level from the input device is switched on and off by the printer for each line advance. If the 306 contains no optional VFU, the user's software can control vertical formatting by counting these line count pulses and terminating the paper movement operation when appropriate.



### 4.7.1 LINE FEED

The line feed operation can be generated by any of the following three conditions:

- (1) After printing a line of characters (and the automatic line feed is not disabled, E1 to E2 is connected) - The low-going forward clutch signal CIP, triggers the LF one-shot.
- (2) Receiving a line feed code (octal 012) - LSI chip ME25 decodes the line feed character and generates a 5-10 usec  $\overline{\text{CSLF}}$  pulse, the trailing edge of which triggers the LF one-shot.
- (3) Pressing the optional LINE FEED switch on the operator panel - Pressing this switch causes  $\overline{\text{REMLF}}$  to go low. This low input to LSI chip ME25 generates a 5-10 usec  $\overline{\text{CSLF}}$  pulse; the trailing edge of which triggers the LF one-shot.

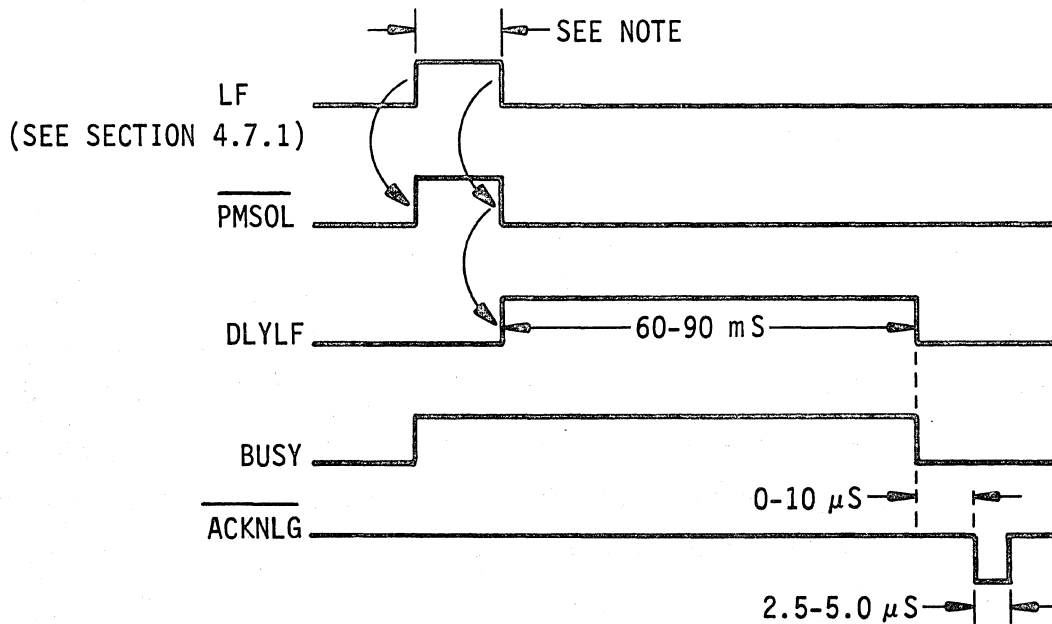

NOTE: 15 MILLISECONDS FOR SINGLE LINE FEED,  
50 MILLISECONDS FOR DOUBLE LINE FEED OPTION

Figure 4-9. LINE FEED TIMING

The width of the LF pulse generated by any of the above conditions is adjustable. In the standard 306 printer, R82 and R83 are not used and jumper E5 to E6 is connected. In this configuration, R20 is adjusted so that a 15 millisecond LF pulse is generated.

If the double line feed option controlled by the optional switch on the operator panel is used, then jumper E4 to E5 is connected and R82 and R83 are used. With the switch in the "double line feed" position, DLF is an open circuit and R20 has no effect on pulse width. R82 should be adjusted to provide a 50 millisecond LF pulse. When the switch is placed in the "single line feed" position, DLF goes to +5V, placing R29 in parallel with R82 and R83. With the switch in this position, R20 should be adjusted to provide a 15 millisecond LF pulse.

While LF is high, LSI chip ME25 generates a low  $\overline{\text{PMSOL}}$  signal which activates the line feed solenoid via the Power Driver board. The trailing edge of  $\overline{\text{PMSOL}}$  triggers the 60-90 millisecond Delay Line Feed interval DLYLF. During both the LF and DLYLF intervals, the printer remains busy.

#### 4.7.2 FORM FEED

A form feed operation can be generated by either of the following two conditions:

- (1) Receiving a form feed code (octal 014) - LSI chip ME25 decodes the form feed character and generates a low  $\overline{\text{PMSOL}}$  signal to activate the line feed solenoid. If the DSC option is used (E10-E11), the line is printed before  $\overline{\text{PMSOL}}$  is activated).
- (2) Pressing the optional TOP OF FORM switch on the operator panel - This generates a low  $\overline{\text{TOFSW}}$  signal causing LSI chip ME24 to generate a low  $\overline{\text{PMSOL}}$  signal.

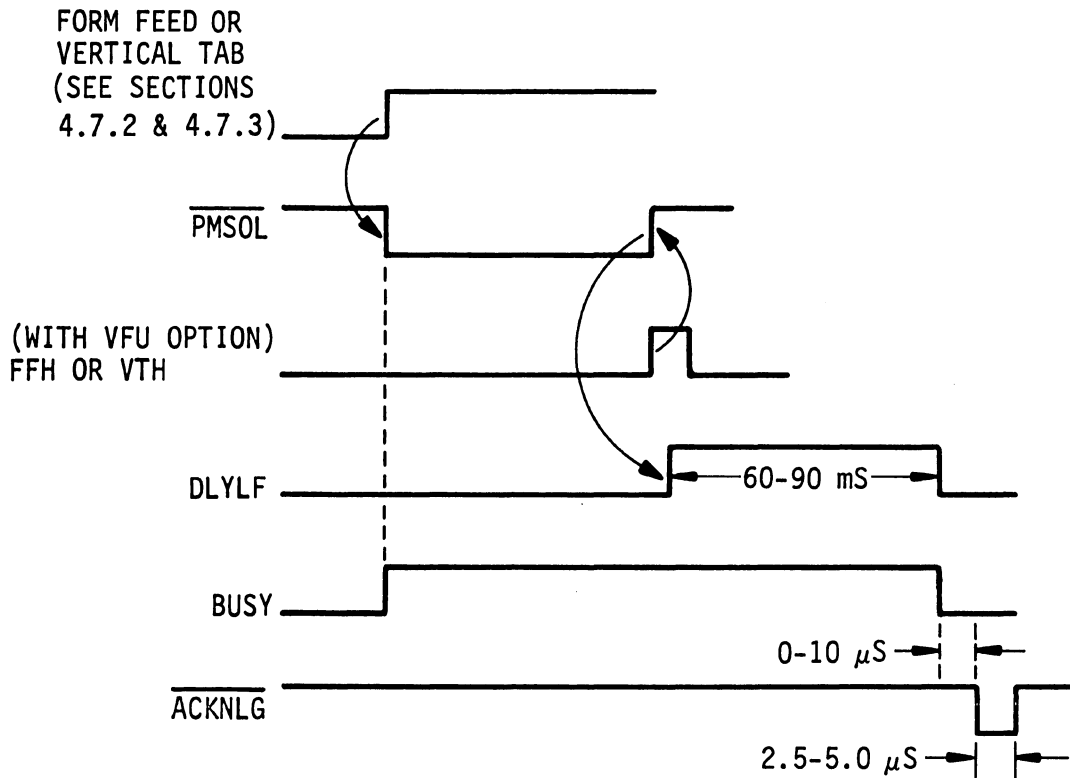

Figure 4-10. FORM FEED AND VERTICAL TAB TIMING

The low  $\overline{\text{PMSOL}}$  signal activates the line feed solenoid and generates a busy condition. This continues until one of the following conditions occurs:

- (1) The input device terminates the operation by sending a delete code (octal 177) or an  $\overline{\text{INPUT PRIME}}$  signal, deactivating  $\overline{\text{PMSOL}}$ .
- (2) A paper time-out condition is detected, at which time  $\overline{\text{PMSOL}}$  is deactivated and the FAULT line is activated.
- (3) If the VFU is used, a hole is detected in channel 7 of the paper tape. This generates a high FFH input to LSI chip ME25, which deactivates  $\overline{\text{PMSOL}}$ .

For as long as  $\overline{\text{PMSOL}}$  is active, the printer remains in a busy condition.

#### 4.7.3 VERTICAL TAB

A vertical tab operation is generated by receiving a vertical tab code (octal 013). LSI chip ME25 decodes the vertical tab character and generates a low  $\overline{\text{PMSOL}}$  signal. If the DSC option is used (E10-E11), the line is printed before  $\overline{\text{PMSOL}}$  is activated.

The low  $\overline{\text{PMSOL}}$  signal initiates the paper movement and generates a busy condition. This continues until one of the following conditions occurs:

- (1) The input device terminates the operation by sending a delete code (octal 177) or an  $\overline{\text{INPUT PRIME}}$  signal, deactivating  $\overline{\text{PMSOL}}$ .
- (2) A paper time-out condition is detected, at which time  $\overline{\text{PMSOL}}$  is deactivated and the FAULT line is activated.
- (3) If the VFU is used, a hole is detected in channel 5 of the paper tape. This generates a high FFH input to LSI chip ME25, which deactivates  $\overline{\text{PMSOL}}$ .

For as long as  $\overline{\text{PMSOL}}$  is active, the printer remains in a busy condition.

#### 4.7.4 VERTICAL FORMAT UNIT (OPTIONAL)

The vertical format unit (VFU) consists of a standard 8-channel paper tape reader, located on the upper left side of the printer. Movement of the paper tape in the VFU is caused by direct mechanical linkage to the gear train that drives the paper feed tractors. As a result, each line feed advances the paper by one line and the tape by one sprocket hole.

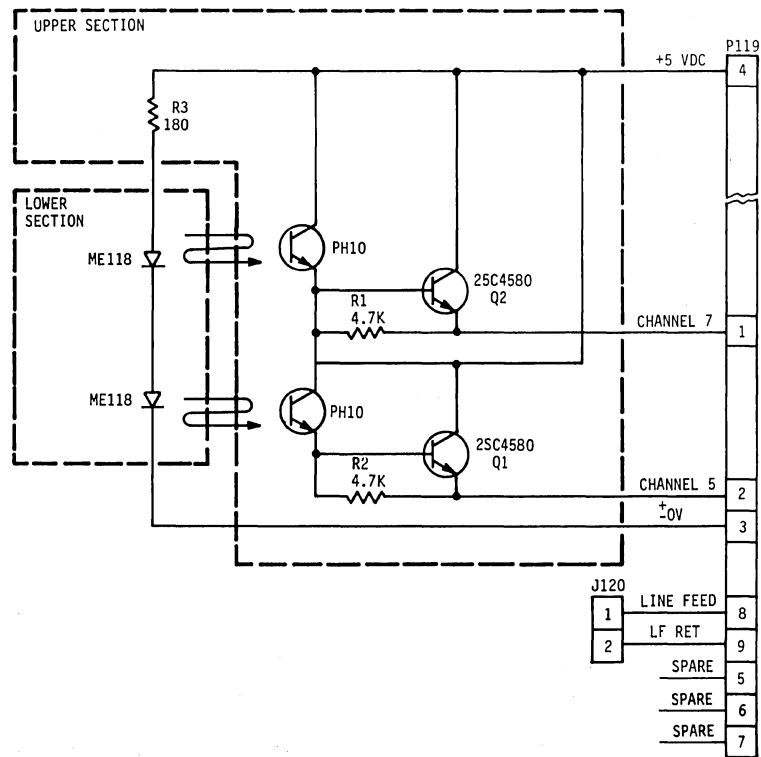

Figure 4-11. SCHEMATIC - VERTICAL FORMAT UNIT

Holes detected in Channel 5 or 7 of the tape are amplified by a VFU amplifier contained in the tape reader unit. Each channel in the vertical format control tape reader contains an input photo transistor, driving an emitter follower amplifier. When the photo transistor receives light, current flows through it and into the base of the emitter follower generating a +5V output.

The two amplifier outputs CHANNEL 5 and CHANNEL 7 are then applied to the logic board and ME25 as VTH and FFH. A 2-4 millisecond delay is designed into ME25 for noise immunity.

#### 4.7.5 LINE FEED SOLENOID DRIVER

Logic signal  $\overline{\text{PMSOL}}$  from LSI chip ME25 is double-buffered by ME21 to generate  $\overline{\text{PMSOLD}}$  to the Power Driver board. When  $\overline{\text{PMSOLD}}$  goes low, ME1-10 on the Power Driver board goes high turning on Q16. This allows current to flow through R40, the line feed solenoid and into the collector of Q16, activating the solenoid. R51 limits the current flow.

When  $\overline{\text{PMSOLD}}$  goes high (inactive), the output of ME1-10 goes low, turning off Q16. The solenoid current then decays through R40 and CR9.

The CLAMP input to the solenoid driver circuit is described in Section 4.6.5.3.

## 4.8 SPECIAL FUNCTIONS

In addition to the paper movement and character printing functions, the printer also performs the following special functions: Bell (optional), Delete, Paper Empty, and Motor Control (optional).

### 4.8.1 BELL (OPTIONAL)

The following description applies only if the optional speaker (526825001) and speaker amplifier is included in the printer. Reception of a bell code (007) or detection of a paper empty condition ( $\overline{\text{PE}}$  goes low), causes a BELL signal to be generated on LSI chip ME25 pin 39. This BELL signal is a 0.8 to 1.6 KHz output approximately one to two seconds in duration. BELL is amplified by Q1 and Q2, and the amplifier output (P3-5 and 7) drives the speaker.

In the 306 printer, a BELL code does not create a busy condition. A paper empty condition, however, still generates a Busy.

### 4.8.2 DELETE

The delete code resets the printer logic by generating a prime condition. Reception of a delete code (octal 177) on the input data lines ANDed with the ungated data strobe DSTA, sets a latch in LSI chip ME25 causing a low  $\overline{\text{DCPRM}}$  output at pin 8 of that chip. The low  $\overline{\text{DCPRM}}$  into LSI chip ME16 causes a high PRIME signal to be generated at ME16-37, resulting in the prime operation as described in Section 4.3.1.

Note that since the delete code is gated with DSTA, the delete code is recognized by the printer even when the printer is busy.

### 4.8.3 PAPER EMPTY

A paper empty condition in the printer is detected by Paper Out switch S6 located in the path of the paper. With paper in the printer, signal  $\overline{PE}$  is high. After the last page passes over the Paper Out switch, signal  $\overline{PE}$  goes low. The low  $\overline{PE}$  into LSI chip ME25: (1) sets a latch internal to the chip which causes a 1-2 second BELL output; (2) causes a high FAULT output, and (3) lights the PAPER OUT lamp on the operator panel.

If the speaker option is used, the BELL output causes an audible alarm, warning the operator of the paper empty condition. The high FAULT output, in addition to causing a busy condition, also goes to the interface connector to indicate a fault status to the input device.

To allow the printer to print the last form, the operator can press the OVERRIDE switch on the operator panel. This causes  $\overline{PE}$  to go high for as long as the switch is pressed.

### 4.8.4 MOTOR CONTROL (OPTIONAL)

The motor control feature causes each print or paper movement command to initiate a 9-second delay. If no other print or paper movement command is received during this 9-second interval, a solid-state switch is deactivated which removes the 115 VAC from the main drive motor. The dc voltages to the printer electronics are not affected.

The motor remains off until the next print or paper movement command is received, at which time the switch is activated and 115 VAC is immediately applied to the motors. If a print command is received, however, the clutch signal is delayed by approximately 250 milliseconds to allow the drive motor to get up to speed. This prevents the possibility of any distortion in the first few printed characters, if the 9 x 7 character option is used.

The motor control logic is contained on the logic board. The motor control switch (39-72001) is attached to a bracket located on the main drive motor.

Referring to the timing diagram in Figure 4-12, one-shot ME31 generates the 9-second interval during which time the Forward Clutch signal ( $\overline{CIPM}$ ), and the Paper Movement signal ( $\overline{PMSOLD}$ ) are monitored.

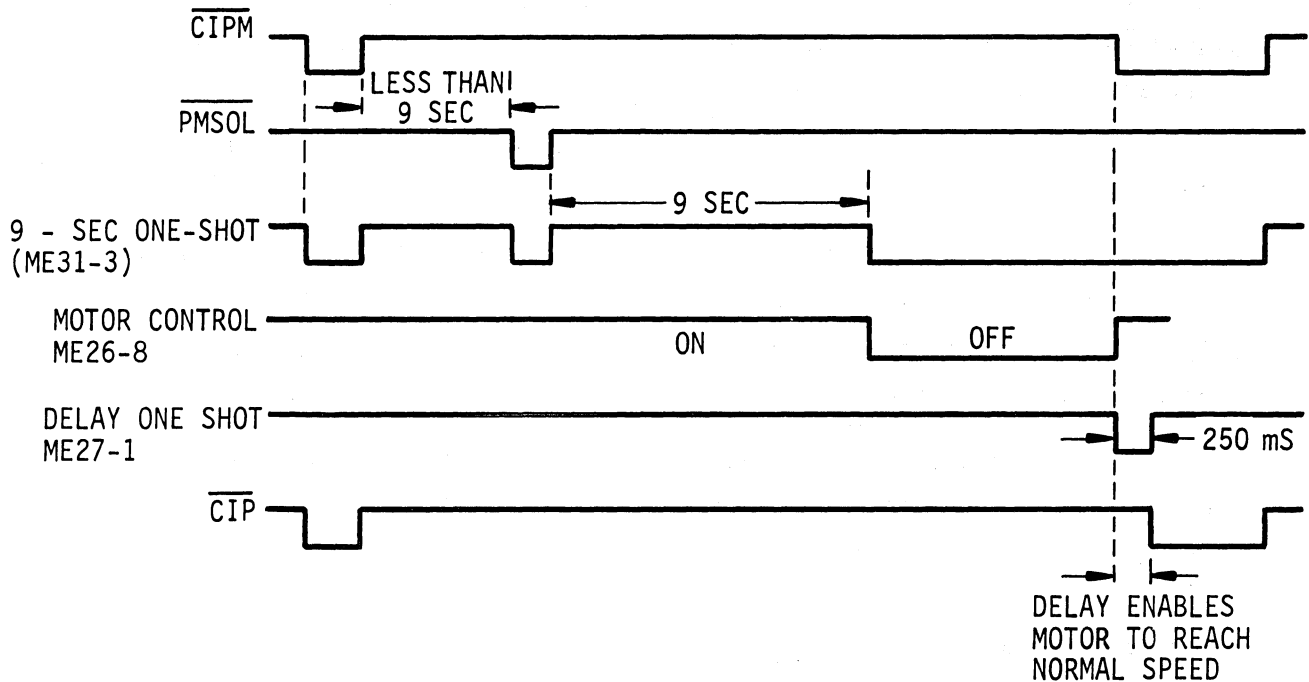

Figure 4-12. MOTOR CONTROL TIMING

The trailing edge of either  $\overline{CIPM}$  or  $\overline{PMSOLD}$  triggers the one-shot causing the output ME31 pin 3 to go high. The resulting low on gate ME26 pin 9 keeps that gate disabled and keeps one-shot ME27 from being triggered. The high output from ME27 pin 1 gates each CIP input through to the Power Driver board as  $\overline{CIP}$ .

If another  $\overline{CIPM}$  or  $\overline{PMSOLD}$  signal is received during this 9-second interval, the low-going leading edge resets one-shot ME31 for the duration of the signal. The solid-state switch and one-shot ME27 remain unaffected during this time due to the low input to gate ME26 pin 10 keeping that gate disabled. The trailing edge of the input signal then re-triggers one-shot ME31 for another 9-second interval.

However, if no  $\overline{CIPM}$  or  $\overline{PMSOLD}$  signal is received during the 9-second interval, one-shot ME31 times-out causing its output ME31 pin 3 to go low.



The two high inputs to gate ME26 pins 9 and 10 then: 1) cause a high input to Delay one-shot ME27, and 2) cause the input to switch K1 to go low deactivating the switch and removing 115 VAC from the motors.

No further action occurs until another  $\overline{CIPM}$  or  $\overline{PMSOL}$  signal is received. At this time, the high  $\overline{CIPM}$  or  $\overline{PMSOL}$  input causes a low at gate ME26 pin 9 which: 1) activates switch K1 and turns on the motor, and 2) triggers Delay one-shot ME27. If a  $\overline{CIPM}$  signal was received, this signal is inhibited from generating  $\overline{CIP}$  by the low input to ME26 pin 12. When the Delay one-shot times-out (approximately 250 milliseconds later),  $\overline{CIPM}$  generates signal  $\overline{CIP}$  which activates the Forward Clutch Driver.

#### 4.9 POWER SUPPLIES

The standard power input to the printer is 115 VAC, 60 Hz\*. This input is fused through a 5 amp. S.B. fuse (F8), and applied through ON/OFF switch S1 to the transformer (T1) and to the main motor (M1) and motor control switch. Components C3 and R3 form a suppression circuit across the ON/OFF switch.

The secondary of the multitap transformer develops the following voltages:

- 27.5 VAC (S1-S3)
- 30 VAC center-tapped (S4-S6-S8)
- 11 VAC center-tapped (S5-S6-S7)

The 30 VAC and 11 VAC voltages are used as inputs to the +5V, +12V and -12V power supplies on the logic board, where they are rectified, filtered and regulated. The unregulated dc outputs from these three power supplies are also regulated on the optional connector board, to provide dc voltages for the optional interface board. The 27.5 VAC is used to generate +35V unregulated.

Connector P1-J1 is used for bringing the ac inputs to the logic card and connecting the filter capacitors and resistors to the +5V and +35V supplies. Connector P2-J2 is used for connecting the power supply outputs to the rest of the printer and for connecting +35V to the power drivers.

\*For the 230 VAC, 50 Hz option, a different transformer and motor is used.

#### 4.9.1 +5V REGULATOR (Figure 4-13)

The 11 VAC output from the secondary winding of the transformer is rectified by diodes CR5 and CR6 and filtered by C1 and R1 located in the cavity. This filtered output is fused through F1 and regulated by regulator element VR1 which maintains the +5 Volt output. Capacitors C11 and C21 provide additional filtering for high frequency transients that might appear at the output. Resistor R43 is a bleeder resistor allowing some current flow through the regulator, keeping it in the active region.

Overvoltage protection is provided by components CR11, R42 and Q4. With the output at a normal +5V, Zener diode CR11 inhibits current flow through R42, holding the gate of SCR Q4 at ground. However, when the output voltage exceeds +6.8V, the Zener diode CR11 conducts, developing a voltage across R42 and turning on SCR Q4. This shorts the input and blows fuse F1.

To simplify troubleshooting procedures for the +5V regulator, as well as the  $\pm$ 12V supplies, the load may be removed from this supply by unplugging J2.

#### 4.9.2 +12V and -12V REGULATORS (Figure 4-14)

The voltage generated by 30 VAC center-tapped secondary winding of T1 is used as inputs to the +12V and -12V regulators. The operation of both circuits is identical to that of the +5V regulator described in Section 4.9.1.

As in the +5V regulator, the load may be removed from these supplies simply by unplugging the J2 connector.

In addition, a jumper connection allows either the +12V output (E24 to E25) or +5V output (E25 to E26) to be connected to the character generators, depending on whether a +12V or +5V ROM is used.

#### 4.9.3 +35V POWER SUPPLY (UNREGULATED) - Figure 4-15

The 27.5 VAC output from the transformer is rectified by diode bridge CR16, 17, 25 and 26 and filtered by R2-C2 to generate the +35V unregulated voltage for the power driver circuits. Four outputs from the logic board (35-1, -2, -3, -4), each individually fused, are used to power the nine driver circuits.

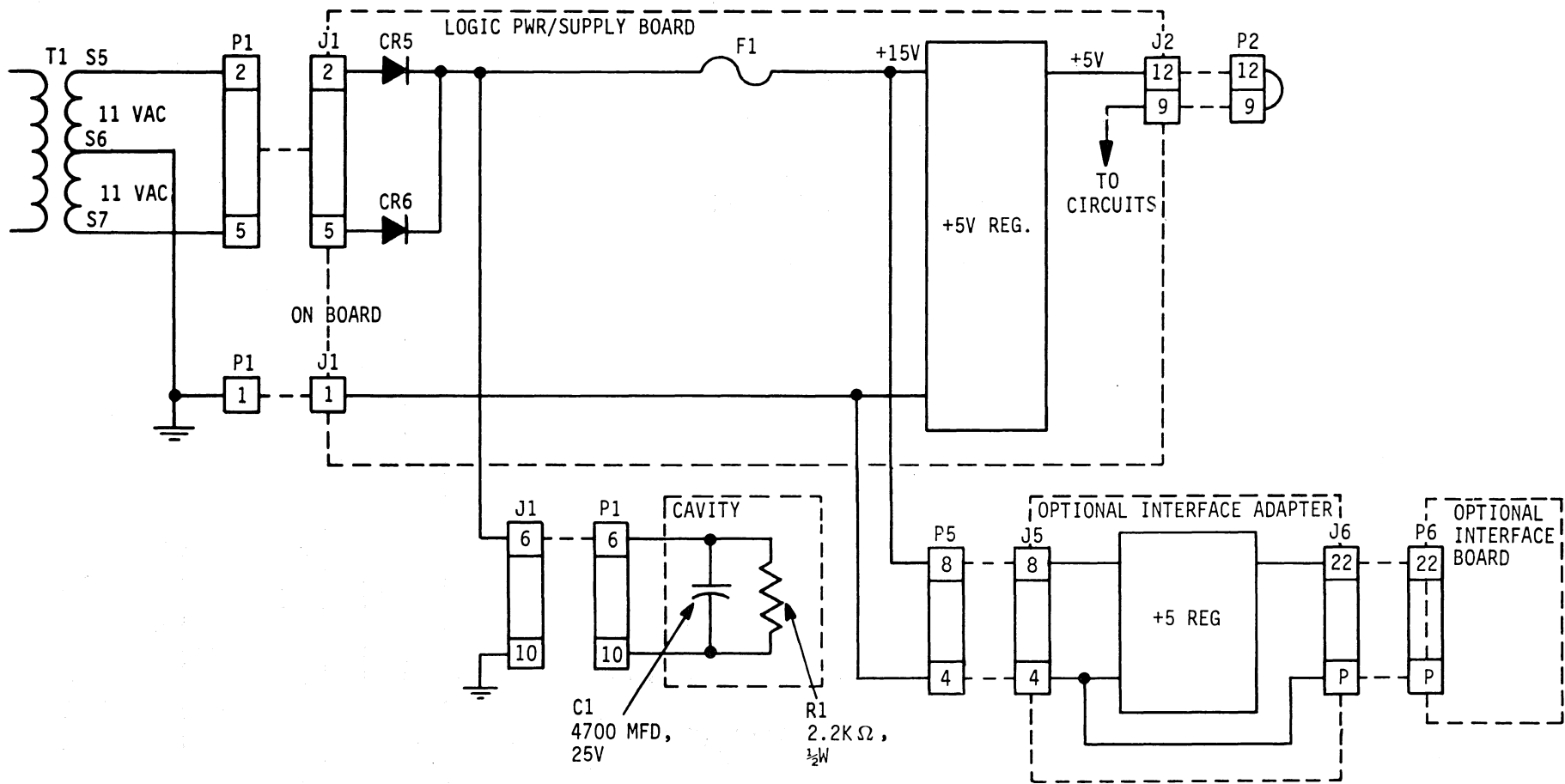

Figure 4-13. +5V REGULATOR INTERCONNECTION DIAGRAM

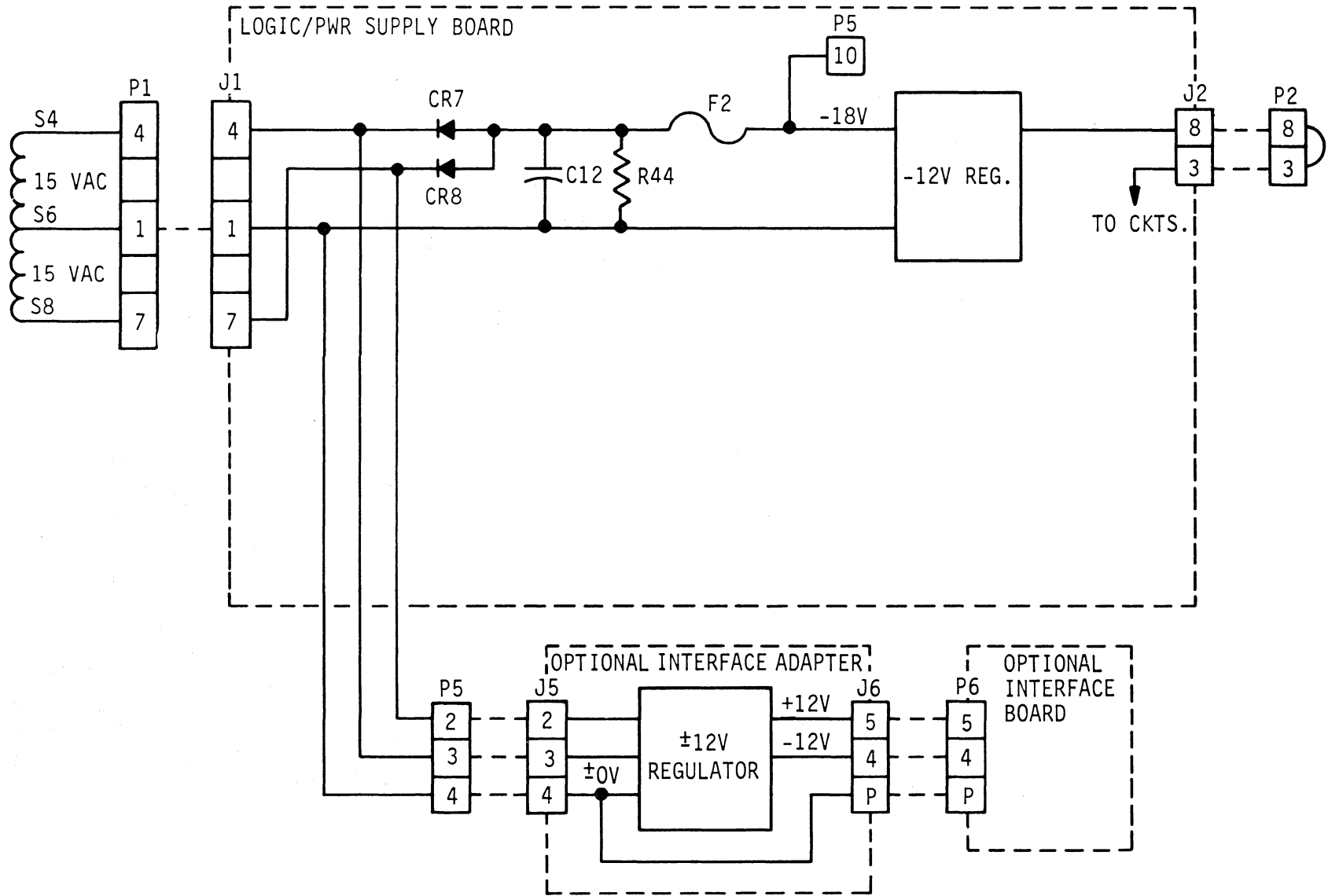

Figure 4-14. -12V REGULATOR INTERCONNECTION DIAGRAM

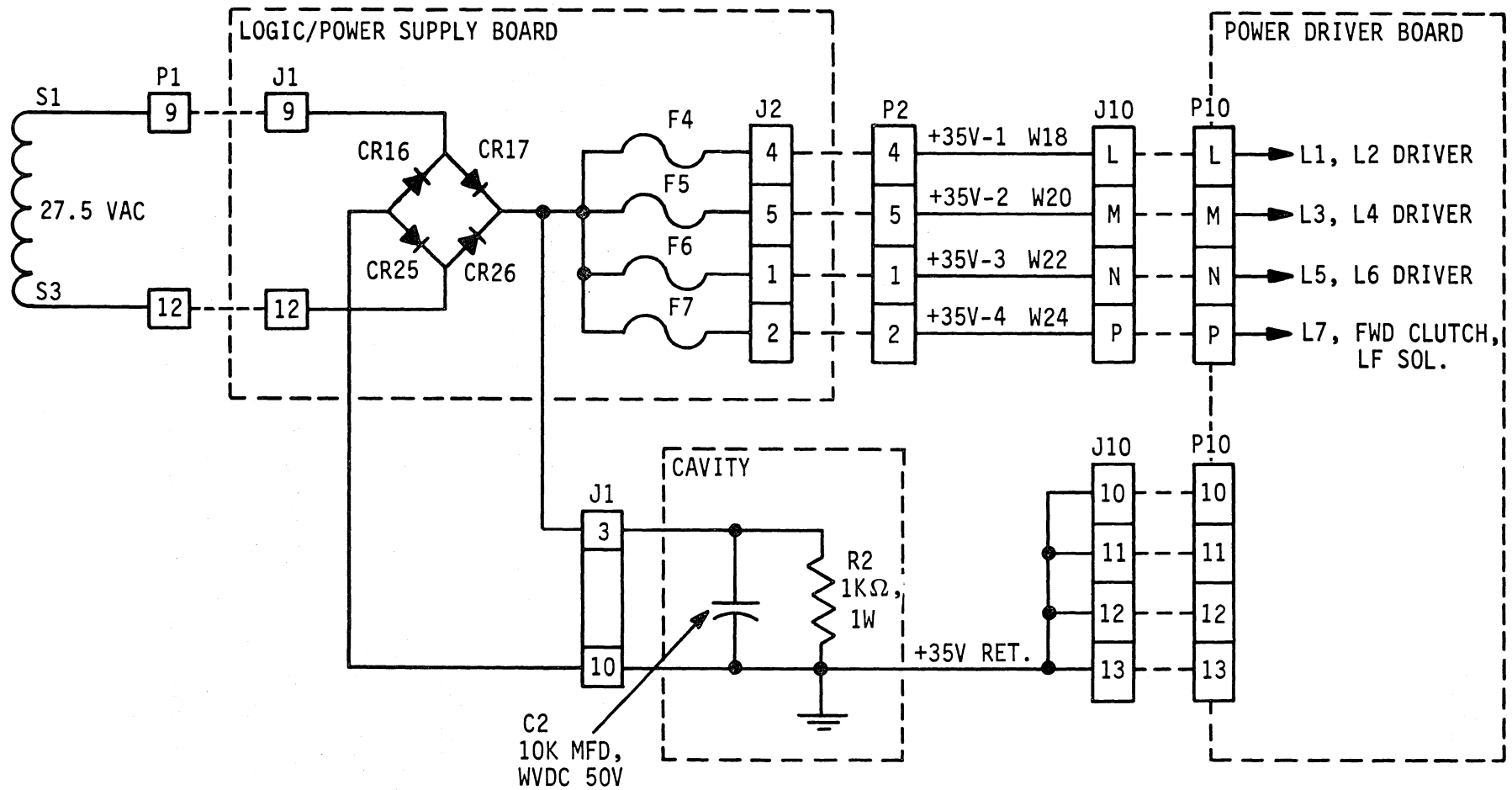

Figure 4-15. +35V UNREGULATED SUPPLY INTERCONNECTION DIAGRAM

## 4.10 OUTPUTS FROM LSI CHIPS (ME25 and ME16)

### 4.10.1 LSI CHIP ME25

#### BUSY (Busy)

Generated on LSI chip ME25 pin 11.  $\overline{\text{BUSY}}$  goes low when any of the following conditions occurs:

- (1)  $\overline{\text{CSBSY}}$  from LSI chip ME16 goes low;
- (2) During a prime condition (PRIME);
- (3) During a paper movement operation (PMSOL);
- (4)  $\overline{\text{DCPRM}}$  from LSI chip ME25 goes low;
- (5) The carriage return code (or if the DSC option is used, the LF, VT or FF code) is clocked into the shift register;
- (6) FAULT from LSI chip ME25 goes high;
- (7) During the 60-90 msec delay following a paper movement operation (DLYLF).

#### ACK (Acknowledge)

Generated on LSI ME25 pin 13. ACK is a 2.5-5.0 usec pulse generated 2.5-10 usec after the trailing edge of data strobe if the printer is not busy, or 2.5-10 usec after the trailing edge of the BUSY signal.

#### (FAULT) Fault Indication

Generated on LSI chip ME25 pin 9. Any one of the following conditions generates FAULT:

- (1) The printer is deselected (SLCT is low),
- (2) A paper-time out condition exists,
- (3) The printer is out of paper ( $\overline{\text{PE}}$  is low), or
- (4) A failure is detected in the video signal ( $\overline{\text{LD}}$  is low).

### SLCT' (Select)

Generated on LSI chip ME25 pin 40. Indicates the status of the Select latch within the chip. This latch is set either by receiving a select code (octal 021) or by pressing the SELECT switch on the operator panel when the printer is deselected. The flip-flop is reset either by receiving a deselect code (octal 023) or by pressing the SELECT switch when the printer is selected. The select and deselect codes affect the select latch even when the printer is busy.

### (BELL) Bell

Generated on LSI chip ME25 pin 39. BELL is a 0.8 - 1.6 KHz signal of 1 to 2 second duration, generated by either a received bell code (octal 007) or a paper empty condition.

### CSLF (Cause Line Feed)

Generated on LSI chip ME25 pin 6. Any of the following input conditions will cause  $\overline{\text{CSLF}}$  to go active (low):

1. Receiving a Line Feed code (octal 012) on input data lines  $\overline{\text{DS1}}-\overline{\text{DS7}}$ . If the DSC option is used (jumper E10 to E11), the complete line of characters will be printed before  $\overline{\text{CSLF}}$  goes low.
2. Pressing the optional Line Feed switch on the operator panel.

$\overline{\text{CSLF}}$  goes back high at the start of the Delayed Line Feed pulse (DLYLF).

### PMSOL (Paper Movement Solenoid)

Generated on LSI chip ME25 pin 7. Any paper movement command (i.e., line feed, form feed or vertical tab). The low  $\overline{\text{PMSOL}}$  output activates a driver circuit on the Power Driver board, which in turn activates the paper movement solenoid on the form feed unit. This causes paper to advance in the printer.

PMSOL remains low until one of the following conditions occurs:

- (1) A paper time-out condition is detected,
- (2) A power prime (PWRPRM) condition exists,
- (3) If the optional Vertical Format Unit (VFU) is used, a hole in channel 7 of the paper tape is reached (FFH) during a form feed operation, or
- (4) If the optional VFU is used, a hole in channel 5 of the paper tape is reached (VTH) during a vertical tab operation.

#### DSCR (Decoded Carriage Return)

Generated on LSI chip ME25 pin 12. DSCR goes active low when a control character (zeroes in bits 6 and 7) is loaded into the shift register. In normal operation, the only control code loaded into memory is a CR code (octal 015). However, with the DSC option (jumper E10 to E11), in addition to the CR code, any of the following control codes may be loaded into memory: LF (octal 012), FF (octal 014), and VT (octal 013).

DSCR goes active on the trailing edge of the gated data strobe and stays active until the printer is primed following the carriage return (and paper movement) operation.

#### DCPRM (Decoded Prime)

Generated on LSI chip ME25 pin 8. Any of the following conditions will cause DCPRM to go active (low):

- (1) Receiving a Delete code (octal 177),
- (2) Receiving a low INPUT PRIME signal at the interface connector,  
or
- (3) A power prime condition (PWRPRM).

#### CLKTB1 (Clock Shift Register Pulse)

Generated on LSI chip ME25 pin 14. The CLKTB1 pulses is used to clock input data into the shift register. It is generated by data strobe signal DSTA whenever both inhibit levels INH1 and INH2 (internal to the chip) are inactive.



If the Gated Strobe (GDSTB) option is used (jumper E7 to E8), INH1 is inactive when the printer is selected and the last input character has been acknowledged by the printer. If the GDSTB option is not used (jumper E8 to E9), then INH1 is always inactive. INH2 is inactive if the character on the input data lines can be stored in the shift register. This occurs whenever the input data lines contain a printable character (a ONE in bit 6 or 7) or after the first printable character is received, a carriage return code (octal 015) is present on the data lines. If the DSC option is used (jumper E10 to E11), a line feed (octal 012), vertical tab (octal 013) or form feed (octal 014) code, could be stored in the shift register after the first printable character is received.

#### Upper Case (UPSC)

Generated on LSI chip ME25 pin 15. A low  $\overline{\text{UPSC}}$  pulse is generated whenever an elongated character code (octal 016) is present on the input data lines.

#### 4.10.2 LSI CHIP ME16

##### DCW1-DCW5 (Strobe Counter Outputs)

Generated on LSI chip ME16 pins 12 ( $\overline{\text{DCW1}}$ ), 13 ( $\overline{\text{DCW2}}$ ), 14 ( $\overline{\text{DCW3}}$ ), 15 ( $\overline{\text{DCW4}}$ ) and 16 ( $\overline{\text{DCW5}}$ ). The strobe counter which is internal to the chip is reset by an internal DCW0 signal. DCW0, which normally represents the space interval between characters, is generated by either a Prime condition or by DCW5.

During normal character printing, each video STROBE pulse increments the counter. During elongated character printing, every alternate STROBE increments the counter, making each DCW interval twice its normal width.

If the special timing option SPCG is used (which consists of cutting the etch between pin 6 of ME16 and  $\pm 0V$ ), then the  $\overline{\text{DCW1-DCW5}}$  signals at the output pins of the chip are encoded from the internal  $\overline{\text{DCW1-DCW5}}$  signals as follows:

<u>External Signal</u>	-	Encoded from	-	<u>Internal Signals</u>
DCW1				DCW1 + DCW3 + DCW5

<u>External Signal</u>	-	Encoded from	-	<u>Internal Signals</u>
DCW2				DCW1 + DCW3 + DCW5
DCW3				DCW4 + DCW5
DCW4				DCW4
DCW5				DCW5

#### DCW01-DCW04 (Delayed Strobe Outputs)

Generated on LSI chip ME16 pins 7 (DCW01), 8 (DCW02), 9 (DCW03), and 10 (DCW04). The delayed strobe counter like the strobe counter is reset by DCW0.

During normal printing of 9 x 7 characters, each DLYSTB pulse increments the counter. During elongated character printing, alternate STROBE pulses increment the counter making each DCW0 interval twice its normal width.

As in the strobe counter timing, if option SPCG is used, then the external DCW01-DCW04 signals are related to the internal DCW01 to DCW05 intervals as follows:

<u>External Signal</u>	-	Encoded from	-	<u>Internal Signal</u>
DCW01				DCW01 + DCW03 + DCW05
DCW02				DCW02 + DCW03
DCW03				DCW04 + DCW05
DCW04				STROBE + DCW)

#### ROME2 (ROM Timing)

Generated on LSI chip ME16 pin 24. This signal is the timing input to the "half-step" character generator ROM (Read-Only Memory).

During normal printing of 9 x 7 characters, each DLYSTB, (Delayed Strobe) pulse generates a ROME2 pulse. When printing elongated 9 x 7 characters, each video STROBE pulse generates a ROME2 pulse.

#### OSC (Oscillator Output)

Generated on LSI chip ME16, pin 25. The frequency of this system clock is 100 KHz (min.) to 200 KHz (max.). Signal OSC is inverted by ME20-6 to generate OSCXT to the interface connector. Signal OSC is also used by both LSI chips to generate clocks Ø1 to Ø2 used internally by the LSI chips.

### CLKTB2 (Clock Shift Register Pulse)

Generated on LSI chip ME16 pin 36. This active high pulse is generated by any of the following three conditions:

1. During a prime condition, to load the du-my character into memory - At the end of the PRIME interval, Recirculate signal SRCL goes high and a single CLKTB2 pulse is generated. This forces a single ONE into bit 8 of that shift register location, forming the dummy character.
2. During character printing, to shift the characters out of memory - Each STROBE pulse occurring during Strobe Counter interval DCWO (internal to LSI chip ME16) generates a CLKTB2 pulse. This shifts the next character to the output of the shift register where it remains until the next STROBE DCWO interval.
3. During the interval following the reception of a carriage return code - A low  $\overline{DSCR}$  input to the chip ANDed with  $\overline{TB8}$  to allow each  $\emptyset 2^*$  clock to generate a CLKTB2 pulse.

### $\overline{CIPX}$ (Forward Clutch)

Generated on LSI chip ME16 pin 30. This active low output is used to turn on the forward clutch when the printer is ready to print the received line of data.

Signal  $\overline{CIPX}$  goes low when the internal CIPF latch is set. CIPF gets set under the following conditions: (1) the printer is not being primed ( $\overline{PRIME}$ ), (2) the right limit switch is not activated ( $\overline{EOPSW}$ ), (3) a control character is not detected at the memory output (TB6 or TB7), (4) the left limit switch is activated (RTPSW), and (5) the dummy character is detected at the memory output ( $\overline{TB8}$ ). The internal CIPF latch then remains set either until the right limit switch is reached (EOPSW) or a control character appears at the memory output ( $\overline{TB6.TB7}$ ). Normally, this control character would be a carriage return code (octal 015). However, if the DSC option is used (jumper E10 to E11), the control character could be a carriage return (015), line feed (012), vertical tab (013), or form feed (014) code.

$\emptyset 2$  is a phase clock internal to LSI chip ME16. The frequency of this  $\emptyset 2$  clock is the same as the OSC output from LSI ME16.

### SRCL (Shift Register Recirculate Input)

Generated on LSI chip ME16 pin 38. A high SRCL signal along with a single CLKTB2 pulse is generated at the end of each PRIME interval. This clocks a dummy character into the shift register.

### $\overline{LD}$ (Light Detect)

Generated on LSI chip ME16 pin 17. Signal  $\overline{LD}$  is normally high indicating no error in the video circuit. However, if the print head travels from the left limit switch (RTPSW) to the right limit switch (EOPSW) with no STROBE pulse generated by the timing fence, then a latch is set within the chip causing  $\overline{LD}$  to go low. This indicates an error condition. The internal LD latch can be reset only by de-selecting the printer.

### PRIME (Prime)

Generated on LSI chip ME16 pin 37. PRIME goes active high for 100-500 milliseconds during a Power Prime ( $\overline{PWRPRM}$ ) and approximately 100-400 microseconds during any of the following conditions:

- (1) A low  $\overline{DCPRM}$  input from LSI chip ME25,
- (2) The printer has just been selected (a low  $\overline{SLCT}$  input to LSI chip ME16) and the Delete Inhibit (DELINH) option is not used (jumper E14 to E15 is not connected),
- (3) A line of data has just been printed ( $\overline{CIPX}$  out of LSI chip ME16 has just gone high).

Prime initializes the printer logic, resets the shift register and loads a dummy character.

### $\overline{CSBSY}$ (Cause Busy)

Generated on LSI chip ME16 pin 35.  $\overline{CSBSY}$  goes active low when a dummy character ( $\overline{TB8}$ ) is detected at the shift register output and a Prime operation is not in progress. This condition indicates that the 80th character has just been loaded into the shift register (without a carriage return code). The low  $\overline{CSBSY}$  signal then generates a low  $\overline{BUSY}$  output from LSI chip ME25.

SECTION 5  
REMOVAL, REPLACEMENT AND ADJUSTMENT PROCEDURES \*

5.1 INTRODUCTION

This section describes the operation, removal/replacement and adjustments (if required) for each major mechanical assembly in the printer.

5.2 MECHANICAL ASSEMBLIES

The mechanical assemblies and their referenced figures are covered in the order listed below. Mechanical drawings and parts lists are contained in Section 8 of this manual.

<u>Section</u>	<u>Title</u>	<u>Figure and Reference Parts Symbol</u>
5.2.1	Carriage Mechanism	AA
5.2.2	Platen	AB
5.2.3	Paper Pan	AC
5.2.4	Driving Mechanism (1)	AD
5.2.5	Driving Mechanism (2)	AE
5.2.6	Idle Pulley	AF
5.2.7	Reed Switch	AG
5.2.8	Base	AH
5.2.9	Frame	AI
5.2.10	Paper Feed (includes optional Tape Reader)	AJ
5.2.11	Pin Feed	AK
5.2.12	Ribbon Feed	AL
5.2.13	Cover	AM
5.2.14	Operator Panel	AN
5.2.15	Electrical Components (1)	AO
5.2.16	Electrical Components (2)	AP
5.2.17	Electrical Components (3)	AQ
5.2.18	Print Head and Associated Assemblies	8-19
5.2.19	Motor Control, Option	5-18
5.2.20	Vertical Format Unit (VFU), Option	8-20
5.2.21	Printer Drive Mechanism, Model 306	5-28

\*All procedures in Section 5 have been updated for Rev. E manual.

## 5.2.1 CARRIAGE MECHANISM (Figure AA)

### 5.2.1.1 Operation

The function of the carriage mechanism is to hold the print head under the best condition to print characters against the platen and to guide the head smoothly from left to right, and return it to the starting position after printing the last character.

At the back left and right edge of the carriage (AA-51) there are six identical guide rollers (AA-52) that function to hold and slide the carriage along the rear guide bar (AB-7). Mounted on the bottom front of the carriage are two retainers (AA-100) that also serve to hold the carriage unit, and at the same time, guide the moving head along the front guide bar AB-12.

The print head bracket (AA-66) mounts on the carriage (AA-51) and slides forward and backward between a head bracket guide plate (AA-75) on the left, and the carriage on the right. The plate is adjustable using two screws (AA-78). Front and back movement of the carriage and head is accomplished by the use of a fork (AA-67) that rotates when the head adjusting knob (AA-58) is turned. As the calibrated head adjusting knob rotates, its eccentric cam and shaft with mounted fork contacts the under side of the moving head bracket (AA-66) and causes it to move forward or backward to a maximum of 0.060-inch travel. The mechanical adjustment is determined by the thickness of the copies to be run. The head lock knob (AA-59) is mounted in the same plane as the head adjusting knob (AA-58) but to the left of the head bracket, and locks the common eccentric shaft to fix the position of the print head in relation to platen (AB-1) prior to printing.

The print head mounts to the head bracket unit (AA-66) by four allen-head screws, two on each side of the head.

When the carriage is positioned over the left or right reed switch (AG-1) a magnet underneath the carriage unit closes either the left or right reed switch, sending a signal to indicate the carriage position to electronic logic.

The carriage and head drive forward by an adjustable driving belt (AE-9) attached to the underside of the carriage between the forward clutch drive pulley (AE-18) and idler pulley (AF-23). A spring (AG-20) attached to the underside of the carriage returns the carriage with the head to the home or starting position (left margin).

A damper cylinder (AA-85), mounted on the extreme left side of the base (AH-1), effectively cushions the returning head and carriage mechanism. The damper action is also aided by an air regulating screw (AA-86) mounted on the left side of the carriage and is center aligned to that of the damper cylinder.

Mounted at the front of the carriage unit (AA-51) is the video amplifier bracket (Fig. 8-1/120) supporting the video amplifier (See Figure 7-18) and cabling to the power driver board (Fig. 7-16).

Mounted at the back of the carriage unit (to right of the center line) are two ribbon guide rollers (AA-62) which maintain proper ribbon operating tension as the head moves out to the right while printing.

#### 5.2.1.2 Removal/Replacement

##### A. PRINT HEAD

(With platen knob (AJ-17), Plate (AJ-18) and Screw (AJ-19) removed)

1. Remove outside covers prior to disassembly, and loosen head locking knob (AA-59).
2. Turn head adjusting knob (AA-58) for maximum gap between platen (See Figure 1-6/12) and front of head (Figure 1-6/1).
3. Unplug solenoid fingerboard (Figure 8-19/9) from video amplifier connector below print head.
4. Using a 3-32-in. diameter allen-wrench, remove at the top, on each side of head bracket unit (AA-66), two allen-head screws (4-40 x .50 lg) and two No. 4 internal lockwashers.
5. Remove from the bottom, on each side of head bracket, two remaining screws (4-40 x .62 lg) and two No. 4 internal lockwashers.

##### B. CARRIAGE UNIT

1. Remove print head (Refer para. 5.2.1.2A, steps 1-5).
2. Remove video amplifier board (See Figure 1-6/2) by removing screws, lockwashers, flatwashers (See Figure AA-96, 97, 98) from bracket attached to carriage unit (AA-51).
3. Remove left and right ribbon spool from printer.
4. Remove left ribbon holder bracket (AL-8) by removing screws, lockwashers, flatwashers (AL-52, 53, 54).
5. Remove right ribbon holder bracket (AL-55) by removing screws, lockwashers, flatwashers (AL-93, 94, 95).
6. Remove nuts (AL-103) from ribbon feed bar (AL-101).
7. Remove screws (AD-38) and washers (AD-39, 40). Rotate bracket (AD-34) out of the way.
8. Slide the rear carriage bar (AB-7) out from carriage rollers (AA-52) by removing screws and lockwashers (AB-27, 28).
9. Remove main driving belt (AE-9) by removing two nuts (AA-105) from belt tension axle (AA-106).

10. Remove carriage spring (AG-20) from D.B. guide plate (AA-107) located on underside of carriage.
11. Lower retainer bracket (AA-101) by removing one inside screw, lockwasher, flat washer (AA-104, 103, 102). Loosen the other side.
12. Lift entire carriage unit from front carriage bar (AB-12).

C. DAMPER CYLINDER

1. Remove left ribbon spool (AL-113).
2. Remove three screws, lockwashers, flat washers (AA-93, 95, 94) from damper cylinder (AA-85) and remove.

D. HEAD BRACKET UNIT

1. To release head bracket unit (AA-66) from carriage unit (AA-51), remove head bracket guide (AA-75) by removing two screws and lockwashers (AA-76, 77). Remove center screw and fork (AA-68, 69, 67).
2. Reassemble in reverse order.

5.2.1.3 Adjustments

A. DAMPER UNIT (AA-85)

1. Piston unit AA-80, mounted to the left side of carriage unit (AA-51) must be aligned on center line with that of the damper unit (AA-85). Loosen three screws (AA-93) on damper, and adjust piston (AA-80) to align with damper when bottomed. Tighten screws on damper when aligned.
2. A critical adjustment of dampening effect for return carriage is the air adjusting screw (AA-86) located on the top of the damper cylinder. Check for the following:  
Condition A  
 Carriage should run out for a full line of characters (80) and return to damper for repeat of 80 character/line readout.  
  
Condition B  
 Make sure printer is capable of one character-per-line printout.
3. If either condition A or B is not met, adjust release of compressed air by turning screw (AA-86) on damper. Air should eject properly from release hole on damper to meet above conditions, A and B; adjust accordingly.

Note

*Avoid bottoming of piston to inside of damper cylinder on final adjustments.*



## B. CARRIAGE MOVEMENT AND RETAINERS (AA-100) (FIG. 5-1 AND FIG. 8-1)

To adjust for proper movement of carriage, perform the following steps:

1. Remove return spring (AG-20) from carriage unit (AA-51).
2. Remove two nuts (AA-105) from belt tension axle (AA-106) and remove main driving belt (AE-9).
3. Loosen two screws (AA-104) at front of carriage holding upper and lower retainers (AA-100). Slightly pivot right-hand side of retainer holder (AA-101) downward to loosen retainers on front guide bar (AB-12).
4. Carriage should now move with hand pressure of about 60 to 80 grams (2-3 oz.).
5. Adjust retainer holder (AA-101) so that retainers (AA-100) are compressed against front guide bar so that a hand pressure of 100-150 grams (3.5-5 oz) will move carriage along the carriage bars.
6. Re-install main belt removed in step 2., including two nuts (AA-105) on the belt tension axle (AA-106).
7. Carriage should move along carriage bars with a hand pressure of approximately 700 gms. (24.5 oz.).
8. Re-install return spring removed in step 1.
9. Loosen lock-nuts (BA-56) on left and right eccentric axles (BA-55). (See Figure 5-1)
10. Turn slotted axles to loosen (or tighten) carriage bearing rollers (surface of roller is lightly touching carriage bar). Retighten axle nuts.
11. Move carriage by hand and observe that rollers are moving smoothly and that carriage is not binding. Hand pressure should be approximately 1.4-1.8 kg (3 to 4 lbs.).
12. If roller bearings are too tight (binding against carriage bar), repeat steps A.9 through A.11.

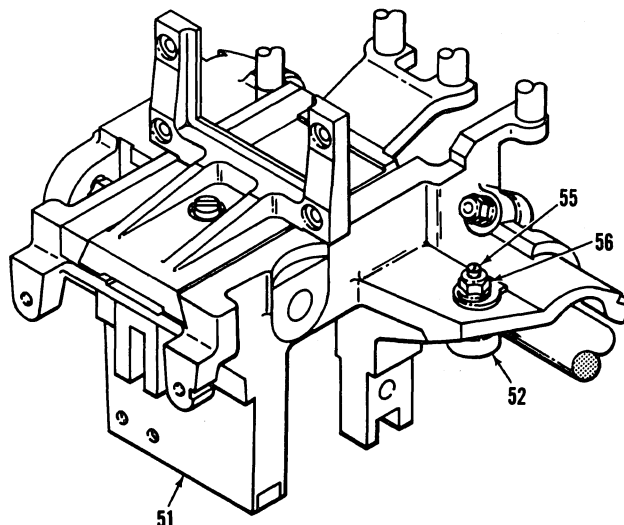

Figure 5-1. CARRIAGE MOVEMENT ADJUSTMENTS

### C. HEAD BRACKET GUIDE

1. The head bracket guide (AA-75) is adjusted to ensure proper operation between the head bracket guide and the head bracket. Adjust two screws and washers (AA-76, 77) on the top of the guide and two adjusting screws and nuts (AA-78, 79) at the side of the guide so that the two surfaces (guide and head bracket) contact, but do not bind when the adjusting knob (AA-58) is rotated.

## 5.2.2 PLATEN (Figure AB)

### 5.2.2.1 Operation

As the print head moves to the right, supported by two removable front and rear guide bars (AB-12, 7), round metallic wires from the print head strike through the print ribbon leaving a dot configuration on the paper. Behind the paper, is a mounted platen (AB-1) providing the hard surface against which the solenoid wires impact.

At the front of the printer, mounted on two vertical posts (part of the printer base) is located the flexible timing fence assembly 63060179-5001, spring clasp 63508140-2001 (left), and a clamp 63508106-2001 (right). (See Figure 8-2)

The Model 306 timing fence (0.007-in. thick) contains 480 windows total for an 80-character run-out, and must be mounted at a prescribed distance from the left post. (Refer to para. 5.2.2.3)

### 5.2.2.2 Removal/Replacement

#### A. PLATEN

Prior to removing platen (AB-1) perform the following steps (to allow clearance for removal):

1. Remove two screws (AI-19) (on right side of frame, AI-1), and remove retainer holder (B), retainer bearing (D), and retainer holder (A) (AI-18, 17, 16). (These are support pieces for paper feed shaft (AI-15)).

2. Slide paper feed shaft to right and remove.
3. Remove screws (AD-2) on larger capacitor (AP-3), and set capacitor aside.
4. Loosen check nuts (AB-6) on screws (AB-5) and remove screws at top and behind platen (AB-7).
5. Remove screws, washers (AB-2, 4, 3) at the back of and underneath the platen, and remove platen from the front of the printer.
6. To re-install platen, reverse disassembly steps A.1. through A.5. above.

Note

*When re-installing platen, adjust screws (AB-5) so that there is a gap of 0.15 mm (0.006-in.) between platen and print head. Tighten nuts (AB-6) making sure adjustment is maintained.*

**B. REAR GUIDE BAR**

1. Perform steps found in para. 5.2.1.2B.4 through B.8.
2. Re-assemble in reverse order of disassembly.

**C. FRONT GUIDE BAR**

(With Video Amplifier Board (Fig. 8-19/26) removed to prevent damage to timing fence)

1. To remove front guide bar (AB-12), remove left and right screw (AB-30) with left guide bar set plate (AB-31) and right guide bar set plate (AB-32).

**D. TIMING FENCE ASSEMBLY 63060179-5001, FLEXIBLE (FIG. 5-2, 8-2)**

1. To remove timing fence, release clamp (Fig. 8-2/41) on right mounting post by loosening two screws, washers (Fig. 8-2/45, 43, 44).
2. Unhook timing fence from spring projection at back of spring clasp (Fig. 8-2/40) and remove.
3. To remove spring clasp and clamp, from right and left mounting posts respectively, remove screws, washers (Fig. 8-2/45, 43, 44). (Some models may have shim/s between post and fence (See Fig. 5-2).

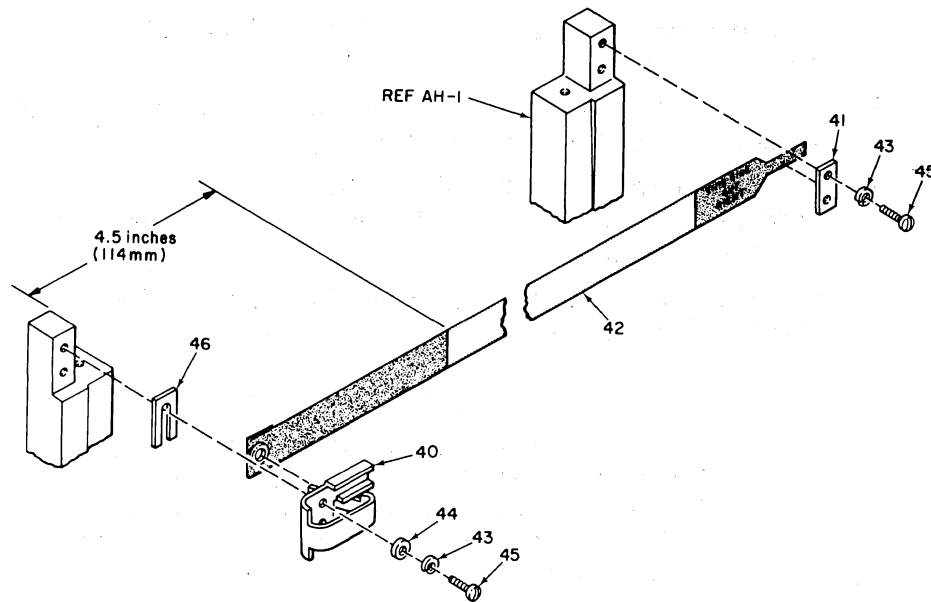

Figure 5-2. TIMING FENCE MOUNTING, MODEL 306

### 5.2.2.3 Adjustments

Note, after adjusting flexible timing fence, refer to Section 5.2.18.3.C. for adjustment of lamp assembly and/or fibre optic head, if required.

#### A. POSITIONING OF FENCE (SEE FIG. 5-2)

- a. Pull tab of fence (42) to the right so that the first window of the fence is located 4.5-in. (114 mm) from right side of left support post. (Note that this dimension adjusts for a nominal 5/8-inch print margin on printing form).
- b. Secure fence under right clamp (41) and when correct dimension has been applied, tighten hardware (43, 45).

#### B. OPTIC HEAD (NO LOCATING DIMENSION) (SEE FIG. 5-2)

1. Set fibre optic head by loosening adjusting screws found on top of video amplifier board (Fig. 8-19/26), and place face of head as close to fence without touching. Tighten screws. Run optic head full length of timing fence insuring that it does not touch fence. (If fence still touches optic head, apply 0.005-in. thick shim/s (46) between clamp (40) and left post). This is done to maintain parallelism within 0.05 mm (0.002-in.) between timing fence and left and right support post.

C. LIGHT ASSEMBLY (NO LOCATING DIMENSION)

- a. Loosen adjusting screws on top of video amplifier board and set light assembly at maximum distance from fence (toward operator). Tighten screws.

D. MAINTENANCE

Timing fence can be wiped clean using micro-wipes (lint free, no abrasives). For more extensive cleaning use mild soap and water. CAUTION: DO NOT USE ANY ORGANIC SOLVENTS

5.2.3 PAPER PAN (Figure AC)

5.2.3.1 Operation

There are two methods used to feed paper to the printer. In the bottom method, the paper is hand fed into a center slot on the underneath portion of the base. A paper pan unit (front) (AC-1) is used to continue the path that guides the paper over the platen (AB-1) where it can be positioned on the pin feed holding units (AK) for print use.

The second method of paper feed is somewhat like the bottom method, except paper is fed from the back of the printer between the paper pan unit (rear) (AC-7) and the paper pan unit (center (AC-4).

An adjustable micro-switch (AC-8) is mounted on the back wall of the rear paper pan with the actuator arm (AC-16) extending through a slot directly over the path of the paper. When paper runs out, the PAPER OUT lamp is lighted on the operator panel. For those models with the optional use of a speaker assembly 526825001, (Fig. AH) an audible buzzer signal is tripped by the switch.

5.2.3.2 Removal/Replacement

A. PAPER PAN UNIT (REAR)

The following procedure must be made prior to removing the paper pan, rear (AC-7).

1. Remove capacitor bracket and capacitor (AI-23) by removing screw and washer (AI-27, 25) from right chassis frame (AI-1) (main motor side).
2. Remove main motor guard (AD-4) by removing two screws and washers (AD-5, 6).

3. Unplug the two cables (Fig. 1-9/3, 4) attached to component board assembly logic/power supply board (Fig. 1-8/1) and remove screws and washers from two support brackets (top) (AI-8, 10) and two support brackets (bottom) (AI-4, 6).
4. Release bracket (part of logic/pwr. board 63060104) holding the input connector of the printer by removing screws and washers from base (AH-1) of printer. (Note that ground wire must be removed at same time).
5. Remove input cable connector 630060119 (Fig. 1-8/8), from logic/power supply board, and set board to the side.
6. Remove printer harness 526783001 with connector (J8) from logic/pwr. supply board (Fig. 7-12).

Note

*To protect PAPER OUT switch actuator (AC-16) mounted on the wall of paper pan the following steps should be followed:*

7. Remove capacitor (AP-3) by removing three screws (AP-2)
8. Remove bracket (AP-1) supporting capacitors (AP-3) and (AP-4) by removing four screws (AP-2) from left frame (AI-12).
9. Remove bracket (AI-4) by removing screws (AI-5).
10. Remove paper pan unit (AC-7) from rear position of printer by removing one screw and washer (AC-13, 14) from each side of pan. Remove pan with mounted switch (AC-8) but avoid bending actuator arm (AC-16) on switch when removing or installing.
11. For installation of paper pan unit (rear) (AC-7), reverse disassembly procedure, para. 5.2.3.2A, steps 1 through 11. (Adjust Paper Out micro-switch (AC-8) for smooth flow of paper, if required).

B. PAPER PAN UNIT (CENTER) (AC-4)

Note

*To remove this middle unit of the three paper pan assemblies, para. 5.2.3.2.A., steps 1 through 7 must first be performed prior to removal.*

1. Remove three screws and washers (AC-5, 6) from underneath printer. Move pan into center slot of base of printer.

2. Pull paper pan outward from flanged position at rear of printer.
3. To re-assemble, reverse order of disassembly procedure.

C. PAPER PAN UNIT (FRONT) (AC-1)

1. Perform the steps indicated at para: 5.2.1.2.A., steps 1 and 2.
2. Remove perforated bottom plate (AH-4) underneath the base (AH-1) of printer by removing four screws and washers (AH-5, 6).
3. Remove bottom screws and washers (AC-5 and 6) from center pan (AC-4).
4. Remove screws and washers (AC-2, 3) from each side, top of paper pan (AC-1).
5. Slip paper pan tabs free of base holes, and pull paper pan upward from the top side of printer.
6. To re-assemble, reverse order of disassembly.

5.2.4 DRIVING MECHANISM (Figure AD, part 1)

5.2.4.1 Operation

For this portion of the driving mechanism (part 1 of 2) continuous drive power from the main motor (AD-49/50) is transmitted to the clutch units (Refer Fig. AD, part 2, which includes air gap and preload clutches) in the following manner:

Motor\* - motor pulley (AD-13/13-1) - belt (AD-15) - Center pulley (AD-24) - Center shaft (AD-23) - Motor pulley (AD-30) - Timing belt (AD-41) - Driving pulley (AE-1) - To clutch unit.

The center pulley (AD-24) is supported on both ends of a center shaft (AD-23) by brackets (AD-34) which contain bronze bearing retainers (B) (AD-35). Located at the back end of the center shaft is a drive pulley (AD-27) which transfers drive torque by means of an O-ring (AJ-29) to the paper feed mechanism. The center shaft also functions to rotate pulley (AD-30) via belt (AD-15) to continue drive power to the pulley (AE-1) for the clutch units (AE, part 2).

The main motor is air cooled by a fan (AD-51) mounted on the shaft of the motor. Air is vented directly through a grid outlet on the base of the printer to the outside. A safety guard (AD-4) covers the fan. To minimize vibration, the motor is cushioned on the base of the printer with the use of a small rubber mat (AD-49). Two holder brackets (AD-49) fix the motor in place on the base. A capacitor (AI-23) is used to filter AC noise, and the motor is grounded with a ground wire strap (AD-45).

\*The 220-volt, 50/60 Hz transformer and motor are optional, as well as the 50 Hz pulley (See Figs. 8-4, 8-16).

This portion of the driving mechanism (Figure AD, Part 1) uses two pulley belts: (1) timing belt (AD-15) used between center pulley (AD-24) and motor pulley (AD-13), and (2) timing belt (AD-41) used between driving pulley (AE-1) and motor pulley (AD-30).

#### 5.2.4.2 Replacement/Removal

##### A. MAIN MOTOR

1. Remove motor capacitor (AI-23) located just above main motor (AD-49/50) by removing screw (AI-7) and washer (AI-25) from right frame (AI-1).
2. Remove motor fan safety guard (AD-4) by removing two screws (AD-5) and lockwashers (AD-6) from printer base (AH-1).
3. Loosen nut (AD-22) located at back of bracket (AD-16) using open end wrench, 5.5 mm (0.22-in.). Remove belt (AD-15) from main motor pulley (AD-13).
4. Remove two main motor holders (upper) (AD-49) by removing screws, washers, and grommets (AD-11, 12, 8) from motor holder (lower) (AD-49) and printer base. Note, that between the lower motor holder and motor there is a rubber cushion (AD-49).
5. Remove ground wire (AD-45) from motor by removing screw (AD-47) and washer (AD-46).
6. To remove fan (AD-51), loosen screw (AD-51) on motor shaft.
7. To re-assemble, reverse order of disassembly (Refer para. 5.2.4.3.A. for correct belt tension adjustment).

#### 5.2.4.3 Adjustments

##### A. MAIN MOTOR PULLEY BELT (AD-15) (REFER TO FIGURE 5-3)

This belt is located between motor pulley (AD-13) and center pulley (AD-24) and proper tension is applied as follows:

1. Loosen nut (AD-22), located at back of bracket (AD-16), with a 5.5 millimeter (0.22-in.) open-end wrench.
2. Adjust position of tensioner (AD-17) so that movement of belt (side away from tensioner) when hand depressed with a pressure of 500 grams (17.6 oz.) travels inward to a maximum distance of 3-6 mm (0.1-0.2-in.). (Reference Figure 5-3)



**B. PREVENTIVE MAINTENANCE, TENSIONER (AD-17)**

1. Apply oil to felt washers (AD-18), located on each side of right tensioner (AD-17), on a normally semi-annual preventive maintenance (PM) basis.

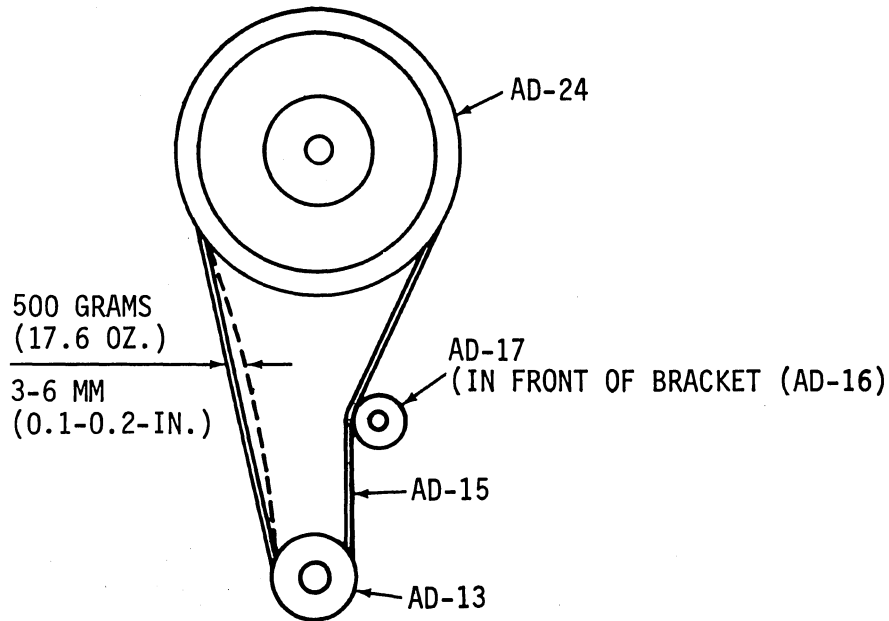

Figure 5-3. ADJUSTMENT OF TIMING BELT (AD-15)  
(View from back of printer, forward)

**C. TIMING BELT (AD-41) (REFER TO FIGURE 5-4)**

This belt is located between the drive pulley (AE-1) of the electromagnetic clutch unit (AE-3) and the motor pulley (AD-30) of center shaft (AD-23). Adjustment of proper tension is as follows:

1. Loosen nut (AD-22), located at front of bracket (AD-16), with a 0.22-in. (5.5 mm) open-end wrench.
2. Adjust position of tensioner (AD-17) so that movement of belt (AD-41) (side away from tensioner) when hand depressed with a pressure of 500 grams (17.6 oz.) travels inward to a maximum distance of 3-6 mm (0.1-0.2 in.). (See Figure 5-4)
3. Belt should not wobble when forward clutch is turned on. Motor should not be under strain (no noise).

**D. PREVENTIVE MAINTENANCE, TENSIONER (AD-17)**

1. Apply oil to felt washers (AD-18) located on each side of right tensioner (AD-17) on a normally semi-annual preventive maintenance (PM) basis.

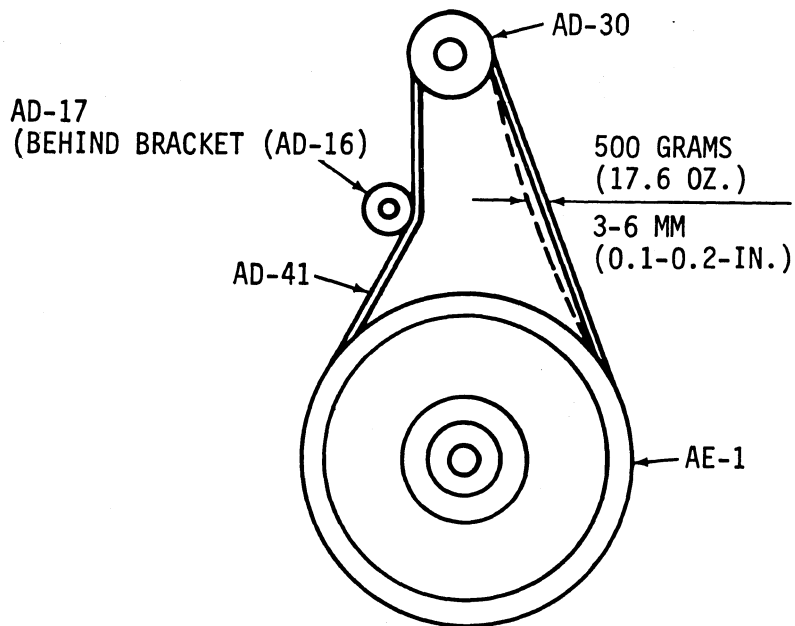

Figure 5-4. ADJUSTMENT OF TIMING BELT (AD-41)  
(VIEW FROM BACK OF PRINTER, FORWARD)

## 5.2.5 DRIVING MECHANISM (Figure AE, Part 2)

### 5.2.5.1 Operation

The function of this driving mechanism (AE - part 2) is based upon two types of clutches used in the printer: (1) air gap clutch or (2) pre-load clutch (later design).

#### A. DRIVING MECHANISM, AIR GAP CLUTCH

This second portion of the driving mechanism (AE) pertains to power transmitted from the drive pulley (B) (AE-1) which rotates clutch shaft (part of AE-3). When the electromagnetic clutch unit (AE-3) is activated by logic signals, the clutch armature (AE-3-3) and driving pulley (C) (AE-18) (for main drive belt) (AE-9) rotate under friction force (via rotor) causing the print head to move to the right. As the carriage, with magnet on the underside, moves over the right reed switch (AG-1), the signal current stops and the clutch armature is restored to open position by springs mounted on it, and torque drive between armature (AE-3-3) and rotor (part of AE-3) is disconnected. The electromagnetic clutch unit (AE-3) is prevented from rotating about its shaft by means of a clutch turning stopper (L) (AE-12) tab mounted on the base of the printer.

B. DRIVING MECHANISM, PRELOAD CLUTCH (FIGURE AE, PART 2)

Note

*When using a PRELOAD CLUTCH (AE-36)  
(with splined armature) in Model 306,  
USE POWER DRIVER BOARD ASSEMBLY  
63060105-4005 configured especially  
for preloaded clutch operation and  
four or eight inches per second (IPS)  
paper slew speed. For AIR-GAP CLUTCH  
OPERATION, USE POWER DRIVER BOARD  
63060105-4001.*

This part 2 portion of the driving mechanism pertains to power transmitted from the driving pulley (AE-1) using a preload clutch assembly.

Drive pulley (AE-1) - clutch shaft (AE-34) - rotor (AE-26) - splined armature (AE-27) - hub (AE-28) - spring (AE-29) - drive pulley (AE-18).

The clutch shaft, with fixed drive pulley (AE-1), rotates continuously in a clockwise direction through slip clutch mechanism (AJ-40, 41, 46) in the paper feed mechanism (AJ). This rotation is maintained through a clutch field (AE-30) assembly, and when activated, the splined armature (AE-27) is pulled against the rotor, and friction torque is continued, causing the head and carriage to move in the forward direction (to the right). Drive is disconnected between splined armature and rotor when signals to the clutch field assembly (AE-30) are discontinued; the head and carriage are then under spring (AG-20) return to left margin.

Because of a preload condition (surface to surface contact) between armature and rotor, there is no gap adjustment. The tension against the rotor is maintained by a clutch spring (AE-29) pressing between the fixed, forward driving pulley (AE-18) and the splined armature.

The hub (AE-28) inserts into the splined armature maintaining torque drive for the mounted forward drive pulley at the opposite end.

The clutch field unit (AE-30) is prevented from rotating about its shaft (part of pinned rotor) by means of a clutch turning stopper (AE-12) mounted directly to the base of the printer.

5.2.5.2 Removal/ReplacementA. MAIN DRIVING BELT UNIT (AE-9)

1. To loosen or tighten main driving belt, (AE-9), adjust two nuts (AA-105) located on under side of carriage (AA-51).
2. To remove driving belt (AE-9) from carriage, perform the following:
  - (a) Remove two nuts (AA-105) from belt tension axle (AA-106).
  - (b) Disengage belt by unhooking T-end of belt from left side under carriage. Slide belt over and under idle pulley (AF-23) on the left. Pull belt to the right under driving pulley (C) (AE-18) and out.
  - (c) To replace belt, reverse disassembly procedure. Check adjustments at para. 5.2.5.3.A.

B. DRIVING MECHANISM ASSEMBLY (AE) PART 2 (FORWARD DRIVE AND AIR-GAP CLUTCH ASS'Y)

1. To remove complete driving mechanism assembly as shown in Figure AE (1), perform the following steps:
  - (a) Remove two nuts (AA-105) on belt tension axle (AA-106), and remove main driving belt (AE-9).
  - (b) Remove screw and washer (AE-13, 14) releasing anti-rotation stopper (AE-12).
  - (c) Loosen two allen-head screws (AE-19) on driving pulley (AE-18).
  - (d) Loosen two allen-head screws (AE-2) on driving pulley (AE-1).
  - (e) Loosen nut (AD-22) on left side of tensioner axle (AD-19) (allowing slack to timing belt (AD-41)).
  - (f) Slide timing belt (AD-41) off driving pulley (AE-18).
  - (g) Remove screws, washers (AE-22, 23) and remove left bushing bracket (AE-21).
  - (h) Remove screws, washers (AE-22, 23) and remove right bushing bracket (AE-21).

- (i) Release spacer (AE-17), driving pulley (AE-18), clutch armature (AE-3-3) from left side of the electromagnetic clutch unit shaft. (Move aside main belt to start parts release).
- (j) Release spacer (AE-17), driving pulley (AE-1) and then electromagnetic clutch unit (AE-3, with shaft) from right side.
- (k) Verify proper adjustment of air-gap clutch prior to assembly (Refer to para. 5.2.5.3B).
- (l) Reverse procedure (a) through (j) to re-install.

C. DRIVING MECHANISM ASSEMBLY (AE) PART 2 (FORWARD DRIVE AND PRELOAD CLUTCH ASS'Y

- 1. To remove complete driving mechanism as shown in Figure AE, perform the following steps:
  - (a) Perform para. 5.2.5.2.A. to remove main belt (AE-9).
  - (b) Loosen tensioner (AD-17) against belt (AD-41).
  - (c) Remove screw and washer (AE-13, 14) releasing anti-rotation stopper (L) (AE-12).
  - (d) Loosen two allen-head screws (AE-19) on driving pulley (C) (AE-18).
  - (e) Remove screws and washers (AE-22, 23) on both left and right bushing brackets (AE-21).
  - (f) Slide loosened belt off driving pulley (C) (AE-18).
  - (g) Remove driving pulley (AE-1) and clutch field ass'y (AE-30) from shaft.
  - (h) Remove pinned rotor (AE-34) (with shaft) splined armature (AE-27) hub (AE-28) spring (AE-29) and driving pulley (AE-18).
  - (i) To replace preload clutch unit (AE-36), reverse dis-assembly procedure.
  - (j) Check para. 5.2.5.3.C. for clutch bracket (AE-21) adjustments.

5.2.5.3 Adjustments

A. DRIVE BELT (AE-9) MAIN MOTOR (SEE FIGURE 5-5)

The main drive belt is located between the drive pulley (C) (AE-18) and the idler pulley (AF-23) on the idler pulley shaft (AF-22). With belt in normal operating position, perform the following steps:

1. Adjust main drive belt tension, by turning adjusting nuts (AA-105) on belt tension axle (AA-106).
2. For correct operating tension, adjust belt so that movement (at midway point) corresponds to a hand depression of 500 grams (17.6 oz.) for a maximum downward distance of 6 to 8 mm (0.2-0.3-in.).

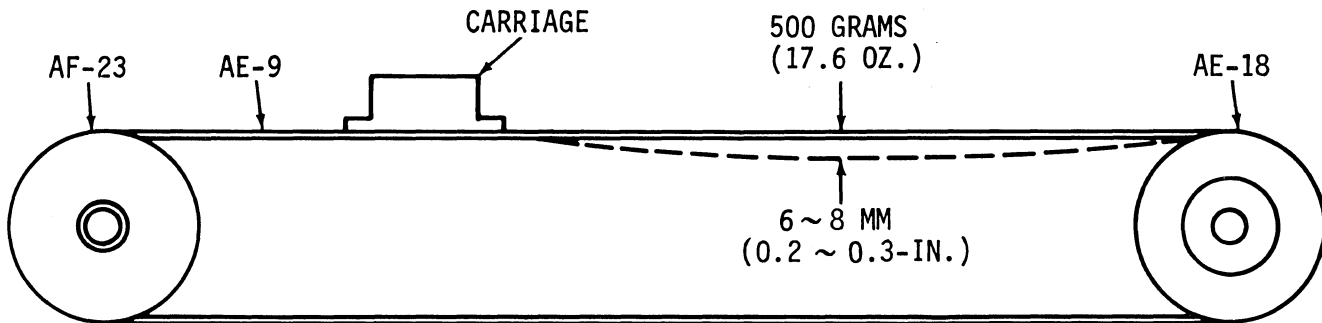

Figure 5-5. MAIN MOTOR BELT ADJUSTMENT (AE-9)

B. FORWARD CLUTCH, ROTOR/ARMATURE (AIR-GAP) (FIG. 5-6)

To ensure smooth and even clutch action, uniform clearance should exist between the engaging surfaces of the armature (AE-3-3) and rotor (part of AE-3) of the clutch unit.

1. Perform para. 5.2.5.2 B.1.(a) through (i) prior to adjusting clutch unit.
2. To adjust for clutch gap, perform the following steps:
  - (a) Loosen three lock nuts on armature (AE-3-3).
  - (b) Using an allen-wrench on the adjusting screws, adjust a clearance of 0.002-0.006 thousandths inch max. (0.06-0.16 mm) between armature and rotor. (See Figure 5-6)
  - (c) Tighten lock nuts and reverse disassembly steps (para. 5.2.5.2 B.1., steps (a) through (i) to install clutch unit.

Note

*Ensure that drive pulley (AE-18) is solidly against the clutch armature when completing the assembly adjustments.*

**CAUTION!**  
 NO LUBRICANT SHOULD BE USED  
 ON THE ROTOR OR ARMATURE  
 CLUTCH SURFACES.

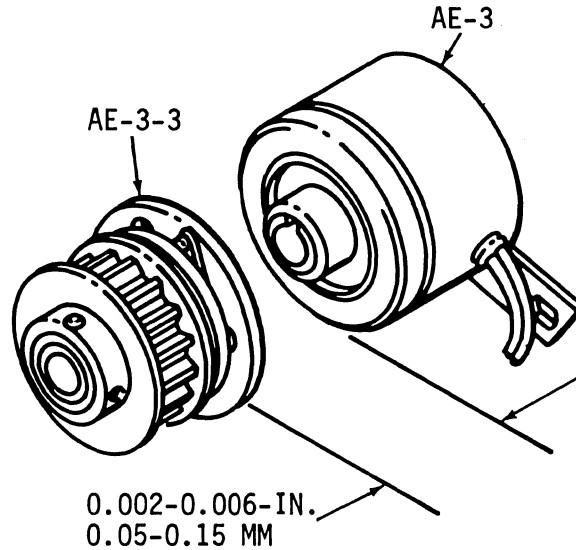
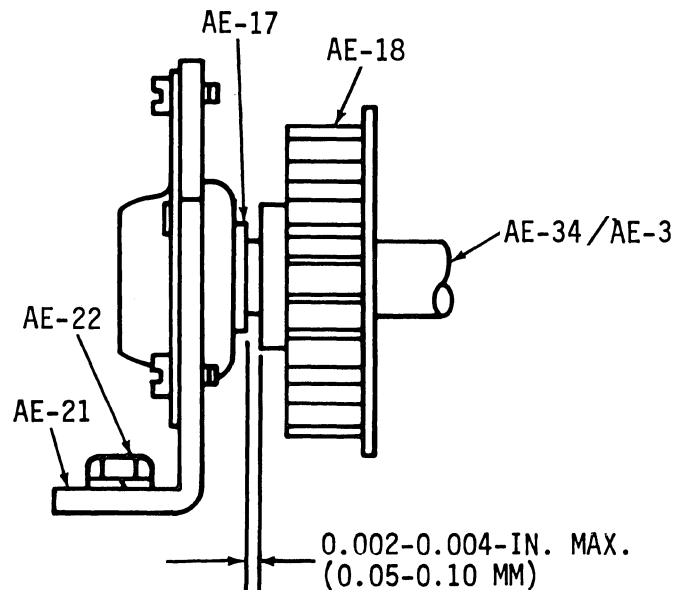

Figure 5-6. FORWARD CLUTCH ADJUSTMENT (AIR-GAP)

C. BUSHING END-PLAY ADJUSTMENT (APPLIES TO BOTH AIR-GAP AND PRELOAD CLUTCH) (REFER FIG. 5-7)

To ensure smooth rotation of clutch shaft (AE-34) (Preload) or AE-3 (air-gap), perform the following adjustments:

1. Tighten screws (AE-22) on rear bushing bracket (AE-21).
2. Loosen screws (AE-22) on front bushing bracket (AE-21).
3. Insert flat gauge between spacer (AE-17) and hub of drive pulley (AE-18). Maintain a gap of 0.002-0.004-in. max. (0.05-0.10 mm) and tighten bracket to this dimension.



SIDE VIEW

Figure 5-7. BUSHING END-PLAY ADJUSTMENT FOR  
 (FORWARD CLUTCH SHAFT (AIR-GAP AND PRELOAD CLUTCH))

D. DRIVING MECHANISM (FIG. AE, PART 2)

1. Bracket (AE-21)

- a. Maintain one back bracket (AE-21) supporting the drive mechanism as far left as possible prior to tightening screws, washers (22) (23). (See Fig. 5-7A)

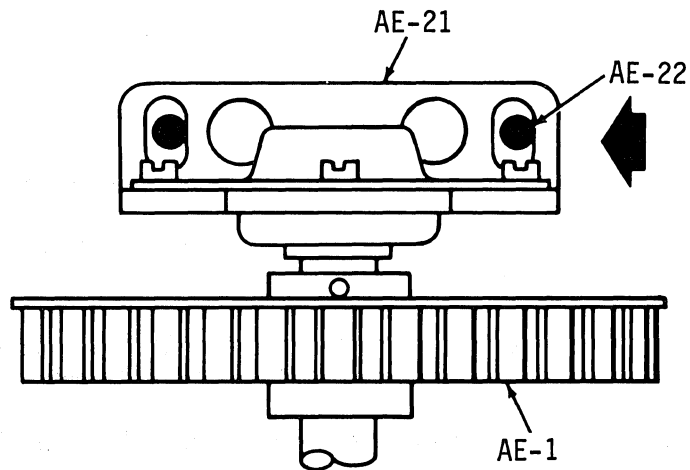

Figure 5-7A. LOCATION OF DRIVE PULLEY BRACKET (AE-21)



## 5.2.6 IDLER PULLEY ASSEMBLY (Figure AF)

### 5.2.6.1 Operation

The idler pulley assembly, located on the left side of the printer, is used to transmit power from the main belt (AE-9) directly to the ribbon assembly mechanism (AL) for both forward and reverse drive.

The unit consists of an idler drive pulley (AF-23) and torque limiter (brake) (AF-31) (part of idler drive pulley), spring return pulley (AF-33) and a pinion shaft (AF-22).

For forward drive of both carriage and ribbon mechanism, power is transmitted from the drive pulley (AE-7) and main belt through the idler pulley (AF-23) to the drive pinion shaft (AE-22).

A rack (AL-1), geared to the rotating pinion shaft maintains the drive for both the left and right ribbon movement (See Figure AL). The rack and pinion motion is continuous with the movement of the ribbon drive mechanism and carriage for forward and reverse direction.

On reverse direction the carriage return spring, under tension, is guided over the return pulley (AF-33). The fixed idler pulley (AF-23), now rotating counterclockwise, transmits reverse torque directly to the rack and pinion, setting up the condition for the next ribbon feed drive and carriage movement when the print head returns under spring tension to the left margin.

The idler pulley and brake, spring return pulley, and pinion shaft are supported by an idler pulley holder (AF-40) which in turn mounts directly to the base of the printer. Should carriage or ribbon drive malfunction, a torque limiter device (brake) (part of idler pulley) permits slippage of pinion shaft protecting forward or reverse ribbon drive linkages.

When the malfunction is eliminated, the brake is reset by moving carriage, by hand, to start position on the printer (See para. 5.2.6.3.A. for adjustments).

### 5.2.6.2 Removal/Replacement

#### A. IDLER PULLEY UNIT (AF)

To remove entire idler pulley unit 527730001, perform the following steps:

1. Remove two nuts (AA-105) on belt tension axle (AA-106) and remove main driving belt (AE-9).
2. Remove carriage return spring (AG-20) between bottom of head/carriage at DB guide plate (AA-107) and return spring bracket (AG-17). Move carriage to right, out of the way.

3. Remove nut, screw, washer (AL-121, 96, 120) holding left ribbon releaser (AL-33 and left rod link (AL-98).
4. Remove screws, washers (AL-52, 53, 54) and remove left ribbon holder plate (AL-8).
5. Remove three screws (AA-93) and washers (AA-94, 95), and remove damper cylinder (AA-85).
6. Remove four screws, washers (AF-41, 42) from printer base (AH-1) and remove entire idler pulley unit (See Fig. AF).
7. When replacing idler pulley unit, reverse removal steps 1 through 6. (Note, in step 1, when replacing main belt, that the ribbon feed rack (AL-1 should be in left-most position, and the idler pulley support bracket (AF-40) is in extreme right position and parallel to center line of printer.

B. IDLER PULLEY SHAFT (AF-22)

1. To remove shaft and parts from idler pulley bracket support (AF-40) perform the following:
  - (a) Apply removal procedures from para. 5.2.6.2.A.1. through 5.2.6.2.A.6.
  - (b) Remove snap ring (AF-34) from shaft (opposite end to pinion).
 

Before removing nut (AF-30) in next step (c), bend nut holder (AF-29) so that nut can rotate.
  - (c) Using a 5.5 mm (7/32-in.) wrench, remove nut (AF-30) and nut holder securing the two ends of brake shoe holders (AF-43).
  - (d) Spread brake shoe holders (AF-43) (with attached brake shoes) and remove small threaded shaft (AF-28) and attached spring (AF-27).
  - (e) Using a 2 mm (0.078-in.) allen wrench, loosen two set-screws on friction sleeve (AF-31), (note that when re-installing sleeve, keep idler pulley in side contact with sleeve and maintain one set-screw on flat of shaft).

- (f) Grasp pinion end of shaft and slide shaft from the following parts:
- (1) Retainer (AF-35) (left).
  - (2) Spacer (AF-39) (Use needle nose pliers to replace).
  - (3) Return pulley (AF-33).
  - (4) Idler pulley (AF-23) (with holders, AF-43).
  - (5) Friction sleeve (AF-31).
  - (6) Retainer (AF-35) (right).
- (g) To re-assemble idler pulley shaft parts, reverse steps at para. B.1.(a) through B.1.(f)(1) - (6).

C. IDLER PULLEY (AF-23) (PART OF BRAKE MECHANISM)

1. To install brake shoe holders (AF-43) (with attached brake shoes) on idler pulley, perform the following steps:
  - (a) Remove complete idler pulley assembly (AF). Refer to para. 5.2.6.2.A.1. through 6.
  - (b) Remove idler pulley shaft (AF-22) (and parts). Refer to para. B.1.(a) through B.1.(f) 4.
  - (c) Remove snap rings (AF-26), and remove brake shoe holders (AF-43) (with attached break shoes).
  - (d) Replace brake shoe holders, and secure with snap rings (AF-26).
  - (e) To re-assemble idler pulley unit and shaft, reverse steps B.1.(a) through B.1.(f)(6).
  - (f) To install complete idler pulley (AF), reverse steps in para. 5.2.6.2.A.1. through 5.2.6.2.A.7.

5.2.6.3 Adjustment

A. IDLER PULLEY (AF-23)(PART OF TORQUE LIMITER (BRAKE) MECHANISM)(FIG.5-8)

1. Perform removal steps at para. 5.2.6.2.A.1. through 5.
2. Using a 5.5 mm (7/32-in.) wrench, turn nut (AF-30) on small threaded shaft (AF-28) (holding spring (AF-27) until tension is off the spring.
3. Finger tighten nut until it comes to rest on top surface of nut holder (AF-29) (with brake shoe holder (AF-43) underneath).
4. Tighten nut three turns from starting position.

Note

*To restore torque limiting device (brake), if malfunction occurs, eliminate cause of malfunction and reset brake by moving carriage by hand to start position on printer.*

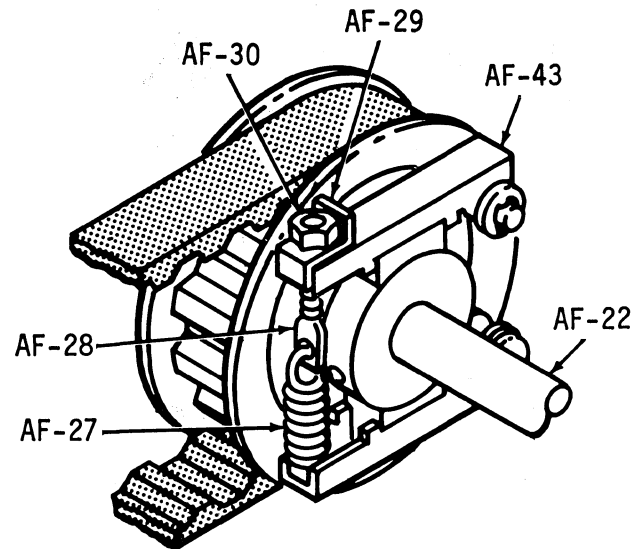

Figure 5-8. TORQUE LIMITING DEVICE (BRAKE)

Note

*Tightening nut (AF-30) three turns (from finger tightened position) is the equivalent of 6 kg Cm (5 in. lbs) of torque to establish break away of the shaft (AF-22), i.e., the point at which shaft will slip if malfunction occurs.*

WARNING

*PRINTER RIBBON DRIVE MAY BE DAMAGED IF OIL OR GREASE CONTAMINATES IDLER PULLEY BRAKE MECHANISM.*

## 5.2.7 REED SWITCH (AG)

### 5.2.7.1 Operation

Two reed switches (AG-1) that control end of print (EOP) (right) and ready to print (RTP) (left) are located above the back of the power driver heat shield at the front of the printer. The bottom of the reed switch holders (AG-9,12) are mounted to the base of the printer; and at the top of the holders, the non-conductive holder (AG-2) and the reed switch (AG-1) are fastened to the adjustable reed switch bracket (AG-7) by two more separate screws and nuts.

The spring (AG-20) for the carriage return is fastened to a return spring bracket (AG-17) on the left side of the printer, coils around the return pulley located on return pulley holder (AG-21) and is then looped under and over second return pulley (AF-33) of shaft (AF-22). It is then attached to the underside of the carriage, slightly to the left of the main drive belt tension axle (AA-106) on the D.B. guide plate (AA-107).

5.2.7.2 Removal/Replacement

A. REED SWITCH (LEFT AND RIGHT) (SEE FIG. 5-9)

1. Remove screw, washers (AG-3, 4, 5) and nut (AG-6) from both reed switches (AG-1).
2. Remove insulating adjusting holders (AG-2) by removing screws (AG-15) mounted to reed switch holders (AG-7).
3. To remove adjusting holders (AG-7) remove screws (AG-8) and washers (AG-25).
4. To remove reed switch bracket holders (AG-9, 12) from base of printer, remove screws (AG-13, 10) and lockwashers (AG-11, 14).
5. To re-assemble reed switch assembly, reverse steps 1 through 4 above.

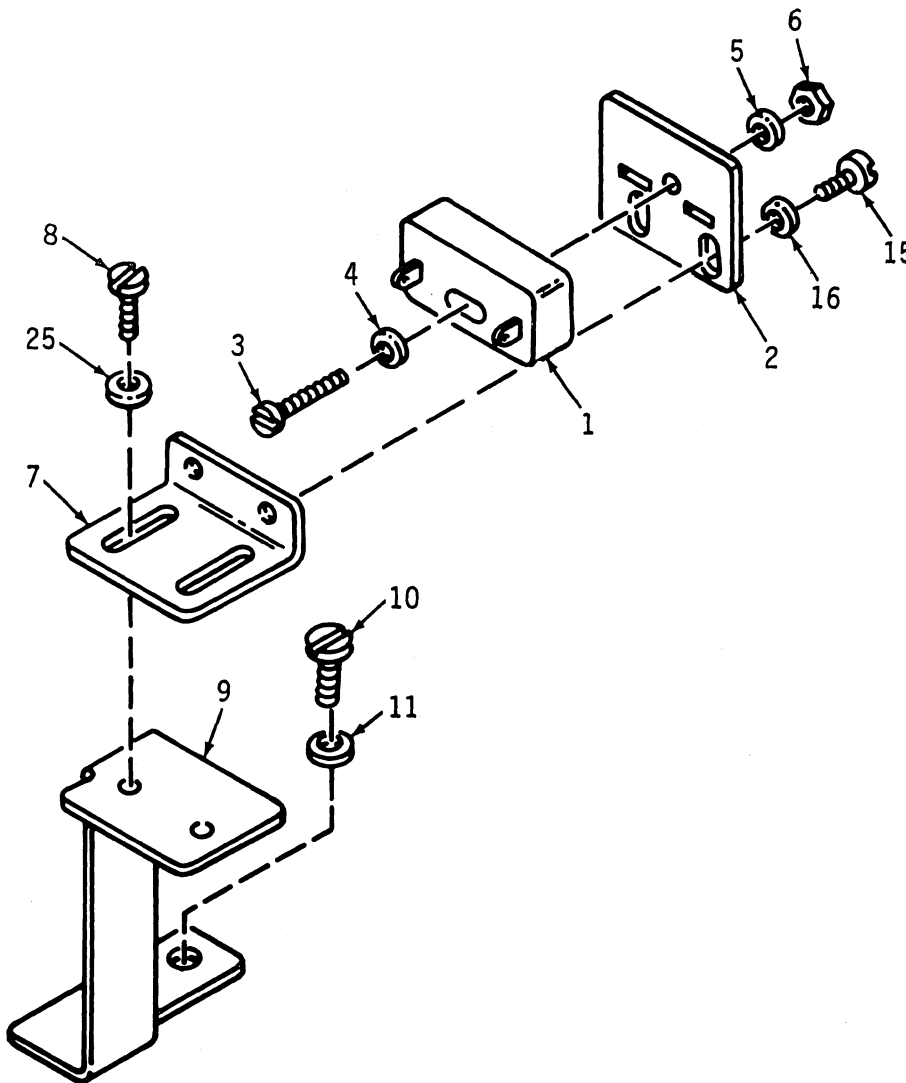

Figure 5-9. REED SWITCH ASSEMBLY, LEFT (AG)

5.2.7.3 Adjustments

A. LEFT REED SWITCH - STATIC ADJUSTMENT (SEE FIG. 5-10)

1. Adjust left reed switch (AG-1) by loosening screws (AG-8) and washers (AG-25) on bracket (AG-7).
2. Slide left reed switch so that the distance between outside, right edge of adjusting holder (AG-2) and the back portion of the left post that holds the front carriage bar (AB-12) is 33 millimeters (1.3 inches).

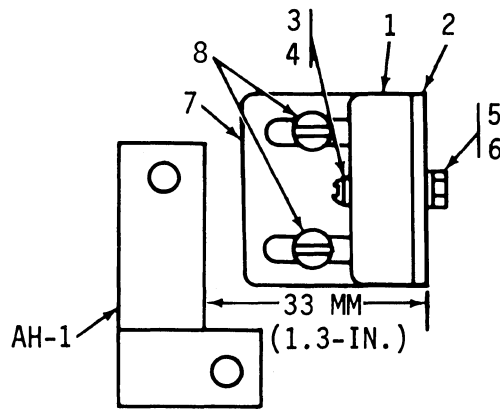

Figure 5-10. LEFT REED SWITCH (AG-1) STATIC-ADJUSTMENT

B. RIGHT REED SWITCH - DYNAMIC ADJUSTMENT

1. The test for the right-hand limit switch (AG-1) is to ensure 80 characters printed. Lines should be transmitted without a carriage return (CR) signal, or exactly 80 characters, to ensure that right limit switch (reed) turns off forward clutch and returns print head to home or left starting position.

Note

*Ensure that the 80th character printed is a whole one (5 or 9 column).*

## 5.2.8 PRINTER BASE (Figure AH)

### 5.2.8.1 Operation

The all aluminum metal base is a self-contained, single unit structured from cast aluminum, oxide protected, which supports the complete electronic and mechanical assemblies in the printer.

A perforated guard plate (AH-4) is located directly under the power driver assembly.

Four 2 x 5-inch removable rubber feet (AH-2) support the base.

An optional speaker (AH-3) is shown mounted in the front, right-hand corner of the base (AH-1) using two mounting screws (AH-16) and bracket (AH-15).

### 5.2.8.2 Adjustment

#### 1. Speaker Option

For electrical installation of speaker option, two wires located at the front, right-hand side of the base are connected to the speaker. The wires are identified as: W91-white/red (coming from connector J8 at pin 7) and the return wire, W104-white/orange (coming from connector J8, pin 5). (Refer to Wiring Diagram (Fig. 7-8) for Model 306 Printer mechanism).

## 5.2.9 FRAME (Figure AI)

### 5.2.9.1 Operation

Two chassis frames right and left (AI-1, 12) support (1) the paper feed guide shaft (AI-20) (upon which are mounted two pin feed tractor units (Refer to Figure AK) and (2) the paper feed shaft (AI-15) which is geared (Refer to Figure AJ) for line feeding of the printer paper. The paper feed shaft rotates on bronze bearings (retainers - AI-17) which are held by retainer holders (AI-16, 18) to the chassis by screws (AI-19).

Located on the left end of the shaft (AI-20) (inside the left frame, AI-12), is a small pin feed stopper (AI-34) which is adjustable when establishing the left print-out margin using perforated multiform paper (See para. 5.2.9.3.).

Four brackets (AI-4, 6, 8, 10) attached to the chassis frames (AI-1, 12) support the logic/power supply printed circuit board, which stands in a vertical position at the back of the printer.

Capacitor (AI-23) for main motor is mounted by bracket at the bottom right of the right-hand frame (AI-1).

### 5.2.9.2 Replacement/Removal

#### A. PAPER FEED SHAFT (AI-15)

1. Refer to para. 5.2.10.2 and perform paras. A and then B, step 1 through 4 prior to removing paper feed shaft (AI-15).

USE NEXT STEP 2. FOR REPLACING BEARING ONLY.

2. Remove screws (AI-19) on left frame (AI-12) and remove retainer holder (A) (AI-16) with retainer (bearing) (AI-17) and retainer holder (B) (AI-18).
3. Remove screws (AI-19) on right frame (AI-1) and remove retainer holder (B) (AI-18) and retainer holder (A) (AI-16) with retainer (D) (bearing) (AI-17).
4. Slip shaft through left paper feed holder (AK-20), belt paper guides (AK-10), and right pf holder (AK-1) to the right, and remove.
5. To reassemble, reverse order of disassembly.

#### B. PAPER FEED GUIDE SHAFT (AI-20)

1. Loosen both locking knobs (AK-18) on paper feed guide shaft (AI-20).
2. Remove nut (AI-22) at right end of guide shaft.
3. Loosen allen-head screw (AI-35) on pin feed stopper (AI-34).
4. Remove slotted head screw (AI-21) from left end of shaft.
5. Slide shaft (AI-20) from the two pin feed tractors (AK-23, 24).
6. To re-assemble, reverse order of disassembly.



### 5.2.9.3 Adjustments

#### A. PIN FEED STOPPER (AI-34) (MAINTAINING 5/8-IN. NOMINAL PAPER MARGIN)

1. Loosen set-screw (AI-35) on pin feed stopper and maintain 0.2-in. (5 mm) dimension between stopper and left chassis (AI-12). Tighten screw.
2. Perform para. 5.2.2.3.A. timing fence adjustment.
3. Set left paper guide plate (AK-21) flush to stopper and lock knob (AK-18).
4. Check for 5/8-in. nominal margin for print out on paper.
5. Recheck fence dimension adjustment (step 2) if margin is not 5/8-in. nominal.

### 5.2.10 PAPER FEED (Figure AJ)

#### 5.2.10.1 Operation

##### A. STANDARD OPERATION

Paper can be moved manually by pulling out and rotating the platen knob (AJ-17). For the standard Model 306 printer the vertical formatting is controlled by the user's software and a line count switch. Each line generates a line pulse to the interface connector on the printer. By keeping count of these pulses, the user's software can terminate the paper movement. Drive torque to operate the form feed clutch is supplied by the center shaft (AJ-37) through an O-ring (AJ-29). Any paper command will energize the solenoid magnet (AJ-65). The armature will then retract from rest position toward the magnet pole piece pulling the solenoid slide with it. This releases the clutch unit (AJ-40, 41). As the clutch release pawl (AJ-79) is released, three internal bearings (AJ-46) in the clutch assembly grip the clutch shaft (AJ-37) and rotate it 180 degrees. This half revolution is equal to paper movement of 1/6 of an inch, or one line. At the end of a line feed, the solenoid slide will engage both the releaser pawl (AJ-79) and clutch tab on the inner cam (AJ-40) disengaging the clutch (the three bearings retract from the shaft).

At the conclusion of a line feed, a back stopper pawl (AJ-31) which rides on the back stop cam and gear (AJ-49), will drop in behind the notched lobe of the cam and prevent counter rotation of the clutch shaft (i.e., downward movement of multi-part paper).

## 5.2.10.2 Removal/Replacement

### A. PAPER FEED KNOB (AJ-17)

1. Remove screw (AJ-19), ornamental plate (AJ-18), and knob.

### B. PAPER FEED GEAR (AJ-74)

To remove paper feed gear, perform the following:

1. Perform step A.1. at para. 5.2.10.2.
2. Remove snap ring (AJ-16), flat washer (AJ-15), and spring (AJ-14). (Be careful of spring tension on washers when removing).
3. Remove paper feed gear, coupling (AJ-73) and knob coupler (AJ-12) as one piece.
4. Loosen allen-screw (AJ-74) on PF gear and remove from PF coupling (AJ-73).
5. For removal of remaining paper feed shaft, refer to Figure AI-15, Section 8 and para. 5.2.9.2.A.
6. Reverse steps B.1. through B.4. to re-assemble.

### C. CLUTCH PULLEY (AJ-44), CLUTCH RELEASER (AJ-41), CLUTCH, INNER CAM (AJ-40), CAM WITH GEAR (AJ-49), COUNTER (AJ-51) AND CLUTCH SHAFT (AJ-37)

The above parts are removed from shaft (AJ-37) in the following manner:

1. Remove snap ring (AJ-39) just inside right PF chassis (AJ-30) on shaft (AJ-37).
2. Remove snap ring (AJ-47) from cam (AJ-40).
3. Loosen allen screws (AJ-50) on inner cam (AJ-40).

4. Loosen allen screws (AJ-62) on cam and gear (AJ-49).
5. Loosen allen screws (AJ-52) on counter (AJ-51).
6. Remove snap-ring (AJ-39) on shaft (AJ-37) (just inside PF chassis, AJ-53).
7. Remove O-ring (AJ-29) from pulley (AJ-44).
8. Pull shaft (AJ-37) from left chassis (AJ-53), but keep inner cam and pulley together as there are three internal bearings (AJ-46) contained on the inside of part AJ-41, releaser, which may scatter.
9. To assemble, reverse disassembly procedure placing O-ring (AJ-29) over pulley AJ-44 as shaft is threaded through parts. When parts are assembled, place O-ring over the driving pulley (AD-27).

### 5.2.10.3 Adjustments

#### A. CLUTCH, INNER CAM/ARMATURE SLIDE

To adjust proper distance of armature slide (part of chassis, AJ-30) with respect to holding the raised tab on paper feed clutch, inner cam (AJ-40) (prior to line feed release), perform the following steps: (Refer to Fig. 5-11 below and mechanical drawing (Fig. AJ, Section 8).

1. Loosen bolts (AJ-75) and washers (AJ-68, 69) on clutch magnet frame (AJ-63) mounted to right-hand paper feed chassis (AJ-30).
2. Slide magnet from on paper feed chassis slots so that the gap between armature slide and raised tab on inner cam (AJ-40) is from 0.004-0.012-in. max. (0.1-0.3 mm). Tighten screws and washers.

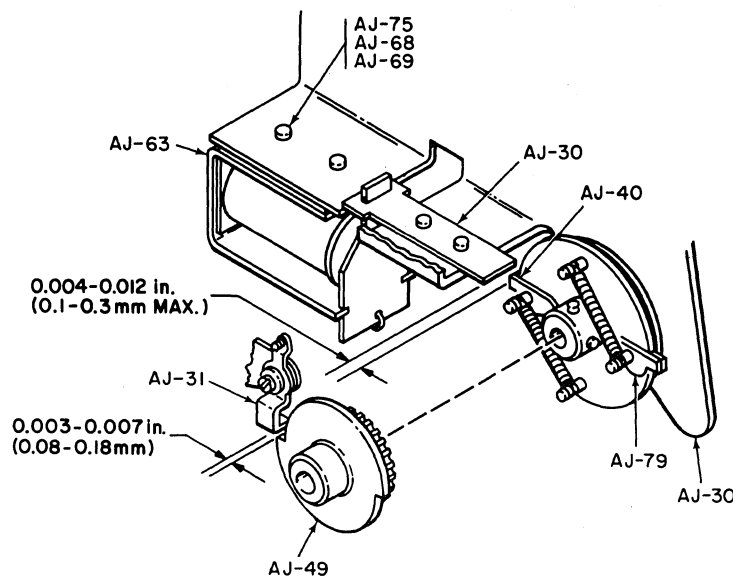

Figure 5-11. TWO ADJUSTMENTS, PAPER FEED MECHANISM (AJ)

B. PAPER FEED CAM AND GEAR (AJ-49)/BACK STOPPER (AJ-31)

As the raised tab on inner cam (AJ-40) and clutch release pawl (AJ-79) strike the armature slide (completing a line feed), it is at this point that the back stopper pawl (AJ-31) (See Fig. 5-12) drops off the notched end of the cam (AJ-49) (Fig. 5-11) and must be adjusted in this position (preventing counter rotation or downward movement of paper).

1. Loosen allen screws (AJ-62) on stop cam (AJ-49) and maintain a gap of 0.003-0.007-in. max (0.08-0.18 mm) between back stopper and notch on cam (See Fig. 5-12). Tighten allen screws on stop cam when gap is attained.

C. LINE FEED COUNTER

The line feed counter (AJ-51) must be adjusted so that both magnets clear the reed switch housing (AJ-4) when activating the internal switch.

1. Loosen two allen-head screws (AJ-52) on line counter (AJ-51).
2. With the armature slide (AJ-64) holding both the tab on the inner cam (AJ-40) and clutch release pawl (AJ-79) (clutch off), set the counter so that within a 90 degree rotation the switch is activated, and then comes to a stop beyond the reed switch housing at each line feed.

5.2.11 PIN FEED UNIT (Figure AK)

5.2.11.1 Operation

Pin feed tractors, left and right (AK-19) Provide pin guides for paper to travel vertically up or down. To move paper down, pull paper feed knob (AJ-17) outward and rotate counterclockwise; to move paper up, rotate clockwise. Tractors are adjustable and are locked in position by fixing knobs (AK-18). Paper holders (AK-1, 20) are used to keep paper on pin feed tractors when printer is in use.

Direct coupling of paper feed knob and paper feed shaft (See Figure AI-15) is accomplished by serrated portion of spring activated knob inserting into opposing serrated coupler (AJ-12).

5.2.11.2 Replacement/Removal

A. PIN FEED UNITS

1. Perform steps A and B of para. 5.2.10.2
2. Perform step A, steps 3 and 4 of para. 5.2.9.2.
3. Loosen two fixing knobs (AK-18) on left and right pin feed units (Figure AK).
4. Remove nut (AI-22) on paper feed guide shaft (AI-20) at right frame (AI-1).

5. Loosen allen screw (AI-35) on pin feed stopper (AI-34).
6. Remove screw (AI-21) on paper feed guide shaft at left frame (AI-12).
7. Remove shaft from left side.
8. To assemble, reverse order of disassembly.

### 5.2.11.3 Adjustments

#### A. PIN FEED HOLDERS AND PAPER GUIDE PLATES (LEFT AND RIGHT)

1. Clearance between pin feed holders (AK-1, 20) and spring activated paper guide plates (AK-14, 21) should be  $0.065 \pm 0.015$ -inch ( $1.65 \pm 0.4$  mm). Adjust clearance by bending right angle metal stopper located just above top hinge pin hole of pin feed holders, left and right (See AK-1, 20).

#### B. PIN FEED BELT UNITS

1. For proper tension of pin feed belt units (AK-19), adjust on the paper feed guide shaft (AI-20) as follows:
  - a. Loosen fixing knobs (AK-18).
  - b. Remove screws (AK-11) to remove belt paper guide (AK-10).
  - c. With a 1.5 millimeter (0.059-in.) allen-wrench, loosen set-screw (AK-2) on paper feed holders (AK-1, 20).
  - d. Rotate eccentric stop sleeve (AK-7). Test for flexibility of pin feed timing belt units (AK-19) so that they are under similar tension on each side, (not too flexible or too tight). Tighten set-screws.
  - e. Re-install belt paper guides (AK-10), and tighten screws (AK-11).
  - f. The difference between the pins in the left and right horizontal plane should be minimal. Adjust as follows:
    - (1) Loosen fixing knobs (AK-18) at top of left and right pin feed holders (AK-1, 20).
    - (2) Slide pin feed units together in middle of paper shaft.
    - (3) Open both paper guide plates (AK-14, 21).
    - (4) Loosen two allen-head set-screws (AK-6) on one pin feed driving pulley (AK-5) with a  $1\frac{1}{2}$  millimeter (0.06-in.) allen-wrench.

- (5) Align pins on belt (AK-19) in same plane. (Sight stoppers on pin feed holders (AK-1, 20) for reference points in same horizontal plane, or insert straight edge supported on stoppers to check alignment of pins).
- (6) Actual alignment can be done by hand moving the belt or pull paper knob (AJ-17) outward and rotate feed shaft (AI-15), which rotates eccentric sleeve (AK-3).
- (7) When left and right pin feed belts are aligned, tighten two set-screws (AK-6) on both driving pulleys (AK-5).

C. PIN FEED STOPPER

1. Refer to para. 5.2.9.3 for adjustment of pin feed stopper (AI-34) if loosened from shaft (AI-20).

5.2.12 RIBBON FEED (Figure AL)

5.2.12.1 Operation

As the printer operates, a left and right ribbon feed mechanism, mechanically linked so as to function when the print head moves, feeds the print ribbon obliquely across the face of the platen (AB-1). The slightly upward angle is maintained by right ribbon spool being located 1½-inches higher with respect to the left lower ribbon spool allowing use of the entire ribbon surface. Two rollers (AA-62), mounted in advance of the moving print head on the same carriage, guide the ribbon across the jewel of the print head. A safety device protects the ribbon mechanism from being damaged allowing slippage in main drive (Refer to para. 5.2.6.3.A.).

A. RIBBON FEED MECHANISM - LEFT

Torque transmission route is as follows:

Idler pulley (AF-23) - Idler pulley shaft (pinion)  
(AF-22) - ribbon feed rack (AL-1 ribbon pawl operator link (L)  
(AL-20) ribbon pawl operator (L) (AL-9) ribbon feed pawl (L)  
(AL-11) - ribbon feed ratchet (L) (AL-189) ribbon with spool  
(AL-113)

B. RIBBON FEED MECHANISM - RIGHT

Torque transmission route is as follows:

Idler pulley, (AF-23), Idler pulley shaft (pinion)  
(AF-22) - ribbon feed rack (AL-1) - Ribbon feed bar (AL-101) -  
ribbon pawl operator link (R) (AL-112) - ribbon pawl operator  
(R) (AL-56) - ribbon feed pawl (R) (AL-58) - ribbon feed ratchet  
(R) (AL-190) ribbon with spool (AL-113).

C. CONNECTING ROD LINK, LEFT AND RIGHT SPOOL

Torque transmission route for ribbon feed mechanism depends upon position of left ribbon releaser (AL-33) or right ribbon releaser (AL-82). The two operate in tandem by a connecting rod link (L) (AL-98) and connecting rod link (R) (AL-97) which is adjustable on the right side of the left rod link. The position of the two connecting rod links is controlled by ribbon release holder (AL-46) located to the left of the ribbon releaser (L) (AL-33). The holder consists of a spring arm and roller upon which the ribbon releaser (AL-33) will ride under tension, but remains positioned when set for either right or left movement of the ribbon.

D. FORWARD AND REVERSE CONTROL RIBBON MOVEMENT

Tension of ribbon is held by ribbon holder (L) (AL-27) and (R) (AL-76) in conjunction with ribbon releasers (R) (AL-82), (L) (AL-33), guide rollers (L) (AL-42), (R) (AL-89), and ribbon tension rollers (L), (AL-37), (R) (AL-86).

If the ribbon, rotating on the ribbon spool (AL-113), approaches the end, two eyelets or stop plate on the ribbon pull the releaser rods (AL-82, 33) and the direction of the ribbon is reversed.

E. RIBBON MOVEMENT - RIGHT

For the transfer of ribbon movement to the right, right rod links (AL-97) must be in position to the right, the gear teeth of the spool feed ratchet (R) (AL-190) engages with drive ribbon feed pawl (AL-58) rotating ribbon spool (AL-113) clockwise. A ribbon stop pawl (R) (AL-79) prohibits reverse motion of feed ratchet when ribbon feeds to the right.

F. RIBBON MOVEMENT - LEFT

For the transfer of ribbon movement to the left, left rod link (AL-98) must be in position to the left, gear teeth on spool feed ratchet (L) (AL-189) engages with drive ribbon feed pawl (L) (AL-11) rotating left ribbon spool (AL-113) counterclockwise. A ribbon stop pawl (L) (AL-30) prohibits reverse motion of feed ratchet when ribbon feeds to the left.

G. STOPPERS - LEFT AND RIGHT (AL-115, 49)

For proper movement of the ribbon pawl operators (AL-9, 56) two stoppers (AL-115, 49) are adjusted to maintain optimum movement of the ratchets (AL-189, 190) (ribbon rotation) with respect to the transference of drive from the rack and pinion (AL-1, AF-22) through the left ribbon pawl operator link (AL-20).

## H. SUMMARY OF RIBBON MOVEMENT FUNCTION

In summary, if motion of ribbon is set for right movement, the right feed pawl drives the right feed ratchet, while left feed ratchet and left stop pawl is disengaged and inactive. On the other hand, if motion is set for left movement of ribbon, the left feed pawl drives the left feed ratchet, while the right feed ratchet and right stop pawl is disengaged and inactive.

### 5.2.12.2 Removal/Replacement

#### A. RIBBON HOLDER PLATE (AL-8), (LEFT)

1. Disconnect ribbon releaser (L) (AL-33) from ribbon rod link (L) (AL-98) by removing screw (L) (AL-96).
2. Remove entire ribbon holder plate (AL-8) by removing four screws (AL-52) and washers (AL-53, 54) from left chassis frame (AI-12).
3. To replace, reverse order of disassembly.

#### B. RIBBON HOLDER PLATE (AL-55), (RIGHT)

1. Disconnect ribbon releaser (R) (AL-82) from ribbon rod link (R) (AL-97) by removing screw (R) (AL-96).
2. To remove entire ribbon holder plate (AL-55) perform the following:
  - a. Remove two nuts (AL-103) and washer (AL-102) from right-hand side of ribbon feed bar (AL-101).
  - b. Remove four screws (AL-93) and washers (AL-94, 95) from right chassis frame (AI-1).
  - c. Remove screws (AD-38), washers (AD-39, 40) from bracket (AD-34) and remove entire ribbon holder plate (AL-55).
3. To replace, reverse order of disassembly.

#### C. RIBBON FEED RACK (AL-1)

1. Prior to removing ribbon feed rack (AL-1), perform para. 5.2.12.2.A.2. and swing left ribbon holder plate out of the way.
2. Move carriage and head to the right, and fasten temporarily. Remove two nuts (AL-103) and washer (AL-102) from left side of ribbon feed bar (AL-101).



3. Remove two screws (AL-6) and washers (AL-7) from printer base post (below left end of platen (AB-1) on side).
4. Remove two screws (AL-6) and washers (AL-7) from printer base post (at left end of rear guide bar, AB-7) and remove ribbon rack feed.
5. To re-assemble, reverse steps 1 through 4.

### 5.2.12.3 Adjustments

#### A. RACK AND IDLER PULLEY SHAFT (PINION) (AL-1, AF-22)

(Perform steps from para. A.1 through A.3 to adjust rack and pinion).

##### 1. Idler Pulley Assembly Positioning (AF-21)

- a. Remove damper (AA-85).
- b. Remove left ribbon holder plate (AL-8).
- c. Loosen four screws, washers (AF-41, 42) holding idler pulley ass'y (AF-21) to base of printer.
- d. Move idler pulley assembly (AF-21) so that unit is located to the extreme right position of mounting holes. Unit must be parallel to center line of printer (Refer to Fig. 5-12).

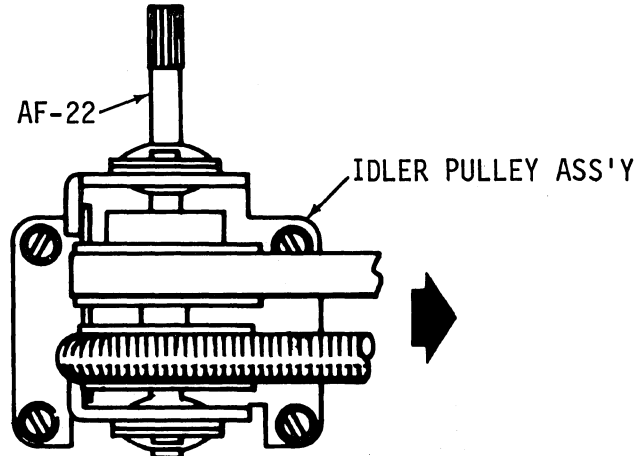

Figure 5-12. LOCATING IDLER PULLEY ASSEMBLY

- e. Replace damper (AA-85).
- f. Proceed to next step, 2.

##### 2. Ribbon Feed Rack (AL-1)

- a. Starting Position Adjustment
  - (1) Push carriage (Fig. 8-1/51) containing piston (AA-80) to left margin until piston bottoms in damper cylinder (AA-85).

- (2) Loosen four screws (AL-6) holding rack guide plate (AL-2) to printer.
  - (3) Raise rack guide plate (AL-2) upwards away from pinion (AF-22).
- b. Rack and Pinion Adjustment
- (1) Move ribbon feed bar (AL-101) by hand so that rack (AL-1) can be adjusted in next step (2).
  - (2) Maintain 7 mm (0.27-inch) between ribbon feed rack (AL-1) and guide rack (AL-2). (See Fig. 5-13)

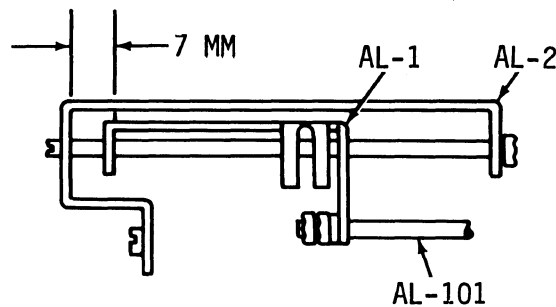

Figure 5-13. LOCATING DIMENSION FOR RIBBON FEED RACK

- (3) When performing next step (4), adjust guide plate so that rack is in a horizontal plane and meshes evenly with pinion gear when head is run out to extreme right by hand.
  - (4) Maintain allowable standard backlash of 0.1 mm (0.004-in.) between rack and pinion teeth. (Move rack guide plate up or down into spline of shaft (AF-22) to establish backlash adjustment, (See Fig. 5-14).
  - (5) When those steps in paras. 2.b.1. through 2.b.3 have been performed correctly, tighten four rack guide screws (AL-6).
3. Torque Limiting Device (Brake) (AF-23)
- a. Perform steps found at para. 5.2.6.3.A.2 through A.4.
  - b. Replace ribbon holder plate (AL-8).

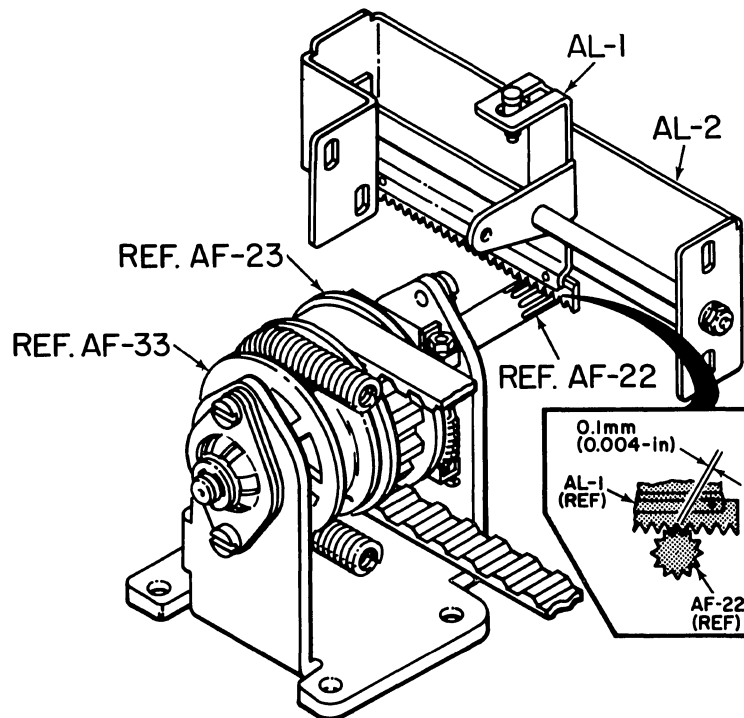

Figure 5-14. RACK AND PINION ADJUSTMENT, RIBBON MECHANISM

## B. RIBBON REVERSE MECHANISM

(Perform steps from B.1 through B.5 for adjustment of Ribbon Reverse Mechanism)

### 1. Dimensioning of Left and Right Ribbon Holder Plates (AL-8, 55)

(Perform steps from B.1 through B.5 for adjustment of Ribbon Reverse Mechanism)

#### a. Left Ribbon Holder Plate (AL-8) (Fig. 5-15)

- (1) Maintain parallelism of plate with respect to printer base and apply distance of 16-17 mm (0.6-0.67-in.) between top of plate and top of rear guide bar (AB-7). See Figure 5-15.
- (2) Tighten mounting screws, washers (AL-52, 53, 51) of bracket when parallelism and correct distance has been attained.

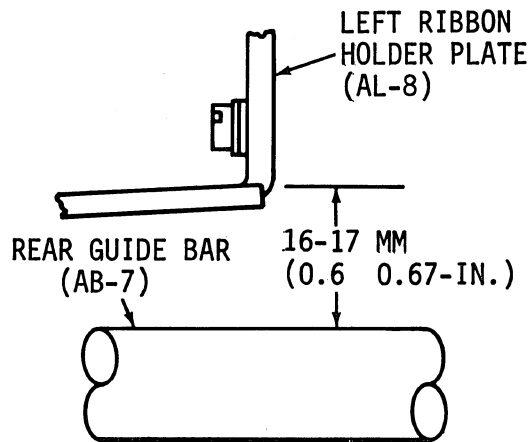

Figure 5-15. LOCATING DIMENSION FOR LEFT RIBBON HOLDER PLATE WITH RESPECT TO REAR GUIDE BAR

b. Right Ribbon Holder Plate (AL-55) (Fig. 5-16)

- (1) Maintain parallelism of bracket (AL-55) with respect to printer base and apply a distance of 41-42 mm (1.6-in.) between top of bracket and top of rear guide bar (AB-7).
- (2) Tighten mounting screws, washers (AL-93, 94, 95) of bracket when parallelism and correct distance has been attained.

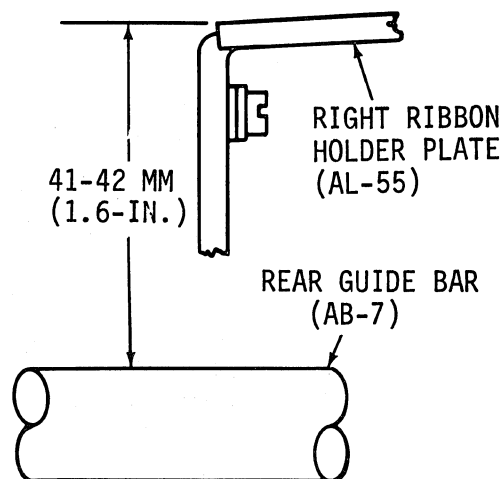

Figure 5-16. LOCATING DIMENSION FOR RIGHT RIBBON HOLDER PLATE WITH RESPECT TO REAR GUIDE BAR

## 2. Left Pawl Operator Adjustment (AL-9)

- (a) Set carriage (containing mounted piston, AA-80) at extreme left margin until piston bottoms into damper cylinder (AA-85).
- (b) Set left releaser (AL-33) to the left.
- (c) Loosen screw (AL-50) on left pawl operator stopper (AL-49) and reset stopper with high side touching the right side of the left pawl operator (See Fig. 5-17). Tighten screw.

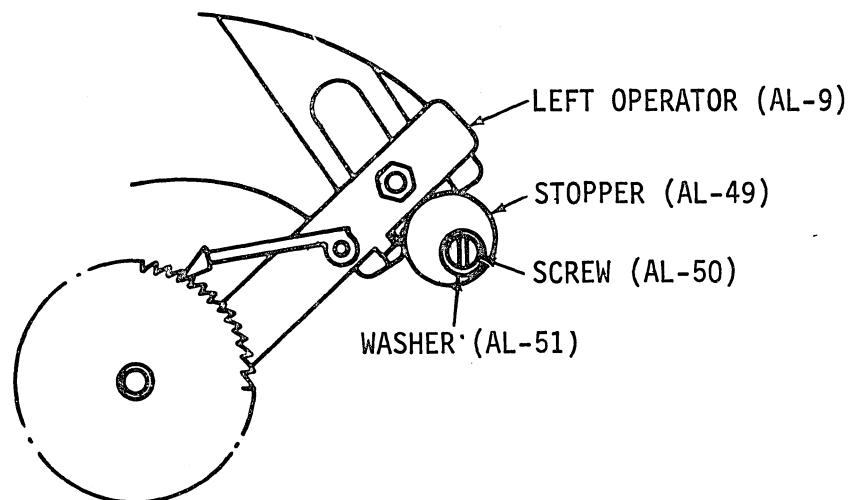

Figure 5-17. LEFT OPERATOR AND STOPPER ADJUSTMENT

## 3. Ribbon Feed Bar (AL-101) (Adjustment for Left and Right Operator) (AL-9, 56)

- a. Ribbon Feed Bar - Left Side (Fig. 5-18)
  - (1) Loosen both nuts (AL-103) on left side of ribbon feed bar.
  - (2) Establish a gap of 0.2 mm (0.008-in.) between washer (AL-102) and ribbon feed plate (AL-1).
  - (3) Tighten nuts (AL-103) up to washer while holding gap at the same time.

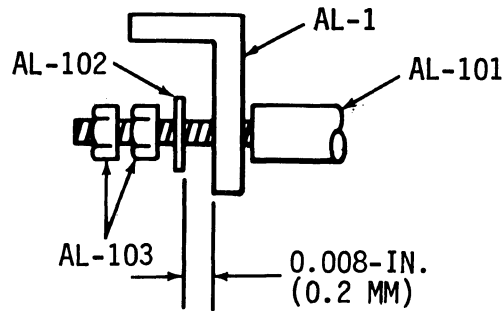

Figure 5-18. RIBBON FEED PLATE AND GUIDE BAR (LEFT SIDE)

b. Ribbon Feed Bar - Right Side (Fig. 5-19)

- (1) Loosen left nut (AL-103) on left side of ribbon pawl operator link (AL-112).
- (2) Maintain 0.1 mm (0.004-in.) gap between nut and right ribbon pawl operator link (AL-112).
- (3) Do not tighten nuts until step 4.b. has been performed.

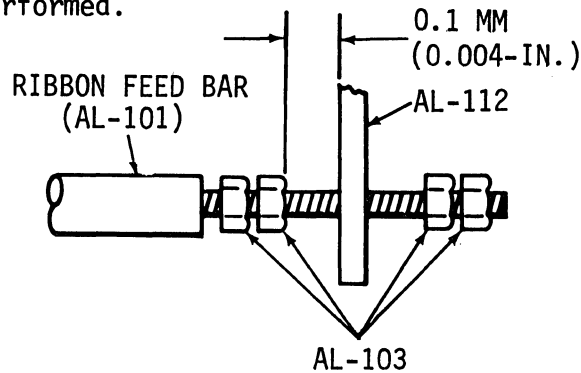

Figure 5-19. ADJUSTING NUTS FOR RIGHT PAWL OPERATOR MOVEMENT

4. Right Pawl Operator (AL-57) Starting Position

- a. Set left side of right pawl operator (AL-56) at a distance of 0.5-1.5 mm (0.02-0.06-in.), as shown in Fig. 5-20).
- b. To adjust and maintain 0.5-1.5 mm (0.02-0.06-in.), between plate and operator, as shown in Fig. 5-20, adjust and tighten nuts (AL-103) referred to in Figure 5-19 (Note that right stop pawl (AL-79) and right feed pawl (AL-58) are fully engaged (Fig. 5-20).

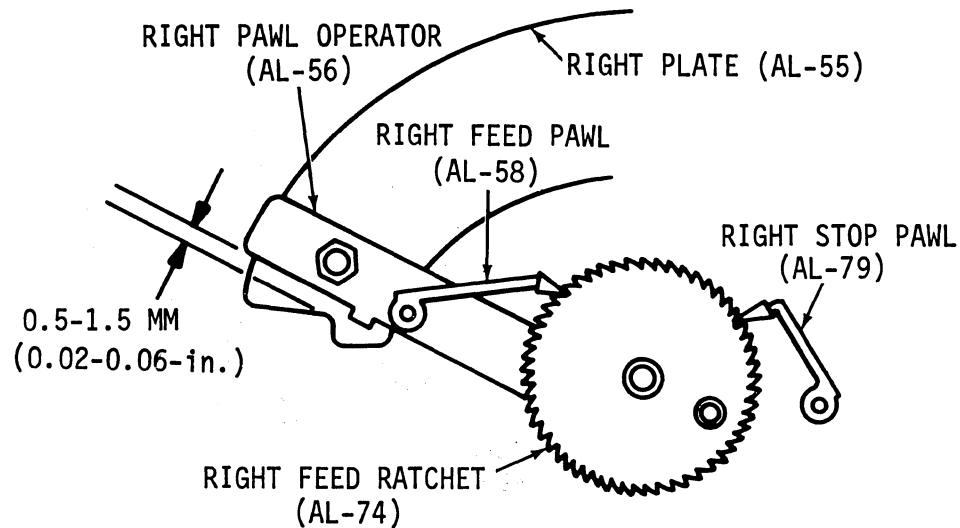

Figure 5-20. RIGHT PAWL OPERATOR STARTING POSITION

#### 5. Ribbon Reverse Adjustment (Left and Right)

- a. Remove left and right ribbon spools.
- b. On left support plate (AL-8) of ribbon feed mechanism, loosen screw, washer (AL-47, 48), and pivot control spring (AL-46) upward and towards the front of the printer (to avoid contact with ribbon releaser (AL-33) (Fig. 5-21).
- c. Loosen two screws, washers (AL-99, 100) just enough so that the ribbon rod links (AL-98, 97) can slide independently from each other.
- d. Adjust the ribbon rod links (AL-98, 97) so that the cam (part of left and right ribbon releasers - AL-33 82) is just contacting the left and right ribbon pawls (AL-11, 58) at that point where the ribbon feed pawls are fully engaged with their respective left and right ribbon feed ratchets (AL-189, 190) (See Fig. 5-21).
- e. When the conditions in step 4 are met, tighten two screws (AL-99) in rod links (AL-97, 98).
- f. Replace the control spring (AL-46); adjust the control spring so that the pointer or spur on the ribbon releaser left (AL-33) is just before top dead center on the control spring roller, and then tighten the screw, washer (AL-47, 48) (Refer to Fig. 5-22).

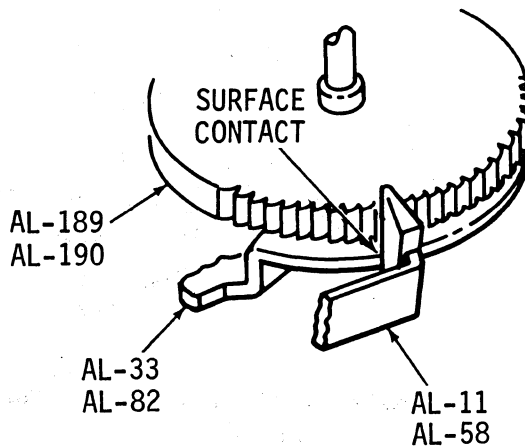

Figure 5-21. PAWL, RATCHET AND CAM MOVEMENT

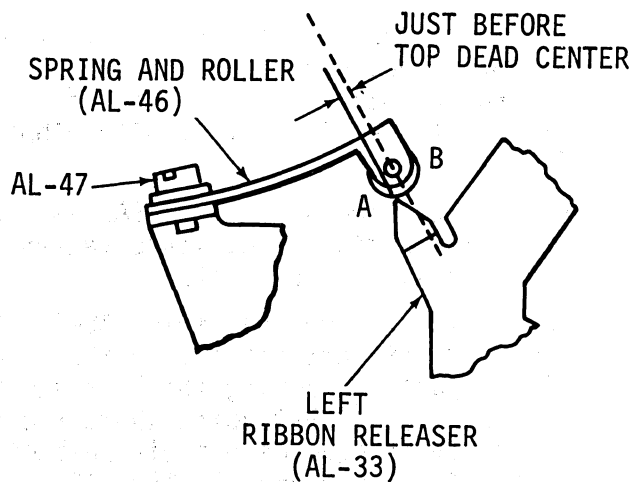

Figure 5-22. SPUR ON LEFT RELEASER (AL-174) AND ROLLER (AL-46)



## 5.2.13 COVER (Figure AM)

### 5.2.13.1 Operation

The covers to the Model 306 printer consist of three structural foam parts: The main cover, top cover and form feed cover.

The main cover is the largest of the three and mounts over the printer, fastening to two posts in the front, and two posts at the back.

The top cover dovetails into the back of the main cover that contains two hinged tabs. If the top cover is closed, it will normally come to rest into two opposing clips (on the main cover) acting as a locking device. An aperture exposing the operator panel is located on the left side.

The form feed cover is the smallest in size and functions as an access to the optional vertical format unit (VFU), when installed. This cover has hinged tabs and a clip into which it normally rests. A recessed well allows hand removal when required.

### 5.2.13.2 Removal/Replacement

#### A. MAIN COVER REMOVAL

1. Remove screw, ornamental plate and platen knob (AJ-19, 18, 17).
2. To remove cover (AM-1) remove two screws and washers (AM-11, 12) from two front posts (part of base, AH-1) and two screws (AM-13) from rear posts.
3. When replacing cover (AM-1), reverse procedure of para. A.1 through A.2.

## 5.2.14 OPERATOR PANEL (Figure AN)

### 5.2.14.1 Operation

The operator panel is located on the left front of the printer where it mounts by bracket to two posts. An additional angular bracket provides support to the panel.

Refer to Operator Manual for control functions indicated on the operator panel.

### 5.2.14.2 Replacement/Removal

#### A. OPERATOR PANEL

1. Remove main top cover (AM-1).
2. To remove operator panel (AN-6) remove four screws (AN-7) and washers (AN-8, 9) from base posts on left side, front of printer.

## 5.2.15 ELECTRICAL COMPONENTS (Figure A0)

### 5.2.15.1 Operation

The power transformer unit (A0-1) (115 volt, 50 or 60 Hz), (220 volt, 50 or 60 Hz is optional), mounts at the back, on left side of the printer with four mounting screws.

The AC power cord (A0-4) is supplied with the printer, and the AC input circuit carries a 3 amp slo-blo fuse (A0-7) (refer to Fig. 7-8, wiring diagram). The fuse cartridge is located at back of printer on the right, seen from back of printer (Fig. 8-i).

Main motor connector wiring (A0-8) is shown on the transformer (Fig. A0-1).

## 5.2.16 ELECTRICAL COMPONENTS (Figure AP)

### 5.2.16.1 Operation

The two capacitors shown are mounted together on a single bracket (AP-1) which is connected to the left frame (AI-12).

Capacitor (AP-3) is used in the 35-volt power supply (unregulated) (Refer to Section 4, Theory of Operation, para. 4.9.3).

Capacitor (AP-4) is used in the +5-volt power supply (Refer to Section 4, Theory of Operation, para. 4.9.1).

## 5.2.17 ELECTRICAL COMPONENTS (Figure AQ)

### 5.2.17.1 Operation

Main harness unit (AQ-1) is supplied with two connectors. (Refer to Fig. 7-9 for wiring diagram).

## 5.2.18 PRINT HEAD AND ASSOCIATED ASSEMBLIES (Fig. 8-19)

### 5.2.18.1 Operation

#### A. PRINT HEAD (FIG. 8-19)

1. Detach top cover (AM-6) from inserted position in main top cover (AM-1).
2. Release lock-knob (22A) and then rotate adjusting knob (22) so that head moves to maximum travel away from platen (AB-1) allowing sufficient gap between print head and print ribbon.

3. Unplug print head fingerboard connector (9) from connector (34) on video amplifier board (26).
4. Remove upper screws, washers (16, 17) and lower screws, washers (18, 17) holding print head to print head support bracket (20). Use diagonal method of removal, e.g., upper left, lower right, upper right, lower left.
5. To install print head, reverse removal/replacement procedure, para. A.1. through A.4., and refer to Operator Manual for Forms Thickness Control prior to printing.

B. CARRIAGE (FIG. 8-19)

1. Refer to removal/replacement procedure of print head carriage (24) in para. 5.2.1.2.B.1. through B.10.

C. POWER DRIVER BOARD (FIG. 8-19)

1. Refer to para. 5.2.18.2.A.1. and detach top cover (AM-6).
2. Unplug ribbon cable connector board (31) from holding clips of power driver board (33) connector (34). Refer to Section 7 for electrical component board assembly, Power Driver 63060105-4001 (air-gap clutch) or 63060105-4005 (preload).
3. Release ribbon cable ass'y (31) coming from video amplifier board (26) to the power driver board (33) by removing screw, washer (35, 36) from cable clamp (37) of cable tray located on the front of the power driver heat sink (48).
4. Remove entire heatsink bracket (48), which includes attached power driver board (33), by removing three counter-sunk metric screws (38) at front of printer attached to printer frame unit (Ref. AH/12).
5. To re-install power driver unit, reverse above disassembly procedure.

D. VIDEO AMPLIFIER AND CABLE ASSEMBLY (FIG. 8-19)

1. Perform steps 1 , 2, and 3 of para. 5.2.18.2.C.
2. Unplug print head fingerboard (9) from holding clips (2) View A on connector (34) of the video amplifier board (26).
3. Remove entire video amplifier board (26) and attached cables (31) by removing screws, washers (28, 29, 30) (View A) from bracket support (47) attached to front of print head carriage (24).

4. To install video amplifier and cable assembly, reverse order of disassembly procedure of this para. 5.2.18.2.D.1. through D.3.

### 5.2.18.3 Adjustments

#### A. PRINT HEAD

Once the print head (13) is bracket mounted to the carriage (24) with attaching hardware (Ref: para. 5.2.18.2.A.), there are no more adjustments except for operator procedure. Refer to Operators Manual, Forms Thickness Control.

#### B. CARRIAGE (LA-9)

1. Refer to para. 5.2.1.3.B. for complete carriage adjustments.

#### C. ADJUSTMENT OF FIBRE OPTICS HEAD (8) AND LAMP ASSEMBLY (43) RELATIVE TO TIMING FENCE (27) FOR CHARACTER GENERATION (FIG. 8-19)

1. Bracket (47) (See also Fig. 8-1, item 120)
  - (a) Loosen screws and washers (28, 29, 30) and push upward on right side of bracket so that top of right angle bend is flush and parallel with surface of printer carriage unit. Tighten allen screws (28) so that slight tap would shift position of bracket.
2. Lamp Holder Housing (43)
  - (a) Remove screw, washers (6, 39, 40) holding lamp assembly (41) and lamp (42). Set assembly aside with attaching hardware.
  - (b) Loosen screws and washers (6, 7) on top of video amplifier board (26) holding lamp holder housing (43).
  - (c) Move housing backwards (towards operator) on screw adjusting slots of board to maximum distance. Tighten screw and washers. (See Fig. 5-23)
3. Fibre Optics Head (8)
  - (a) Loosen screws, flatwashers (6, 7) holding optic head to video amp. board (26).
  - (b) Move optics head toward timing fence (27) but not touching. (See Fig. 5-23). Allow lead of optic bundle (part of fibre optic head, 8) to hang freely.

Note

The following adjustments must be made to simulate correctly aligned lamp (GE-379) so that when adjustments are final, the lamp (42) is inserted and this light source is then directed properly through the timing fence (27) to slit on fibre optic head (8) (Fig. 5-23).

- (c) Adjust front face of fibre optics head so that it is physically parallel with timing fence and as close to fence without touching (Fig. 5-23).
  - (1) If face of optics head is not parallel with respect to the vertically suspended timing fence, physically bend the bracket (47) slightly up or down to maintain vertical parallelism. Tighten screws (6) on optic head (8).
  - (2) Move print head by hand along front and rear guide bars (25, 21) all the way to the right and back to starting position to ensure that timing fence and the face of the fibre optic head surfaces do not touch each other.
  - (3) If surfaces are contacting, re-check timing fence alinement at para. 5.2.2.3.A.

4. Sighting Through Lamp Housing (43)

- (a) From a position in front of flexible timing fence, and with fibre optic bundle pointing to a light source, sight through lamp housing timing and observe illuminated slit on optics head (8) on other side of fence. When sighting, make sure light slit is completely blocked by any black line on the timing fence (See Fig. 5-24/A) (adjust by carriage movement).

The following two conditions may apply to the illumination in previous step 4.(a) when the slit on optics head is out of alinement with respect to the black line on timing fence (Fig. 5-24, A).

- (b) If the bracket (and board, 47, 26) holding the optics head is too high on right (Figure 5-24, B), tap bracket to aline slit and black line as shown in Figure 5-24, A).
- (c) If the bracket holding the optics bundle is too high on the right (Fig. 5-24, C), tap bracket to aline slit and black line as shown in Fig. 5-18, A).
- (d) When correct alinement has been attained, tighten and secure bracket (47) with the two mounting screws and washers (Fig. 8-19/28, 29, 30) to printer carriage (24).

5. Final Mechanical Adjustments for Optics Signal in Character Generation Timing

- (a) Insert lamp (42) (GE-379) into socket assembly (41) attached to lamp retainer (part of lamp ass'y), but note that prior to insertion into lamp ass'y, be certain lamp filament (inside lamp) is in a vertical plane paralleling slit with respect to the opposing fibre optics head (for maximum blockage of light by black line on fence (Fig. 5-24, A). Insert lamp retainer (part of lamp ass'y), and tighten screws, washers (6, 39, 40).
- (b) Install optic bundle lead of fibre optic head (8) into photo cell housing ass'y (3) installed on the top center of video amplifier board (25). Tighten screw, washer (4, 5) on clamp of photo cell housing.

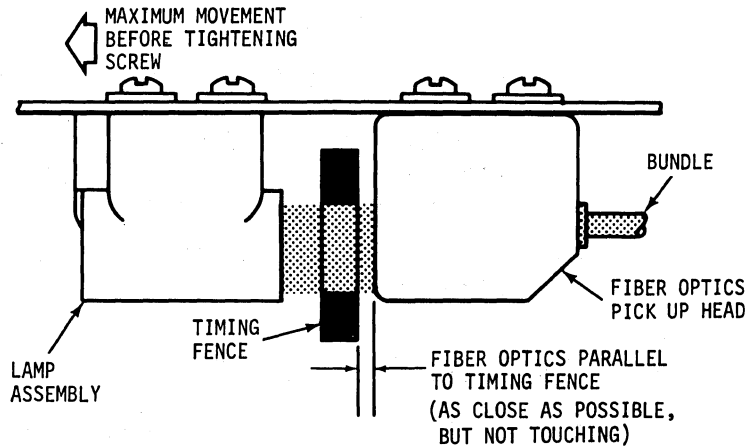

Figure 5-23. FIBRE OPTICS HEAD, ADJUSTMENT FROM OPTIC FENCE

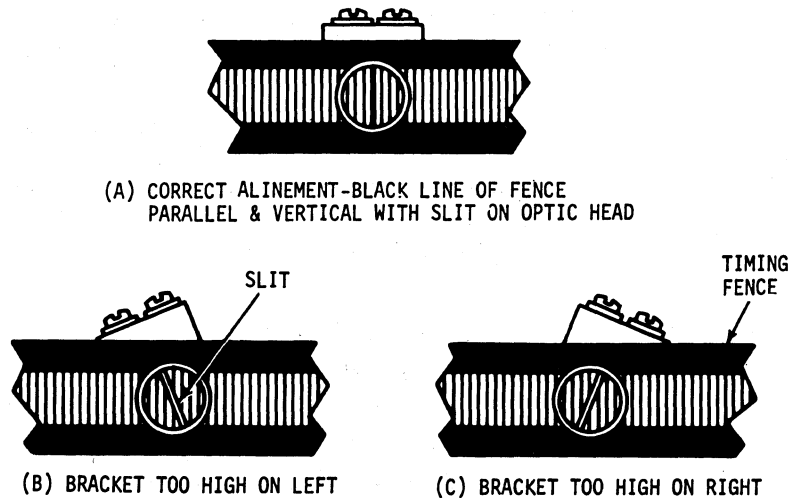

Figure 5-24. FIBRE OPTICS HEAD ALINEMENT AND FLEXIBLE TIMING FENCE

## 5.2.19 MOTOR CONTROL ASSEMBLY OPTION

Note that choice of Kit used is based on the following part numbers:

- a. Kit, Motor Control 63060188-6001, 110 volts.
- b. Kit, Motor Control 63060188-6002, 230 volts.

5.2.19.1 Operation

The motor control operates to turn the main motor on and off when the printer is not receiving data.

5.2.19.2 Removal/Replacement

1. Remove main cover.
2. Disconnect wht/blk and wht/brn wires (coming from the logic wiring harness) to terminals 3 and 4 on the relay (See Fig. 5-25).
3. Disconnect two red wires coming from power wiring harness at back of motor (BD-1), to terminals 1 and 2 from the relay (See Fig. 5-25).

Note

For installation of Motor Control Option, reverse above steps. On Logic/Power supply board 63060104 (Fig. 7-14), remove jumper from ME26, pin 2 to ME26, pin 11.

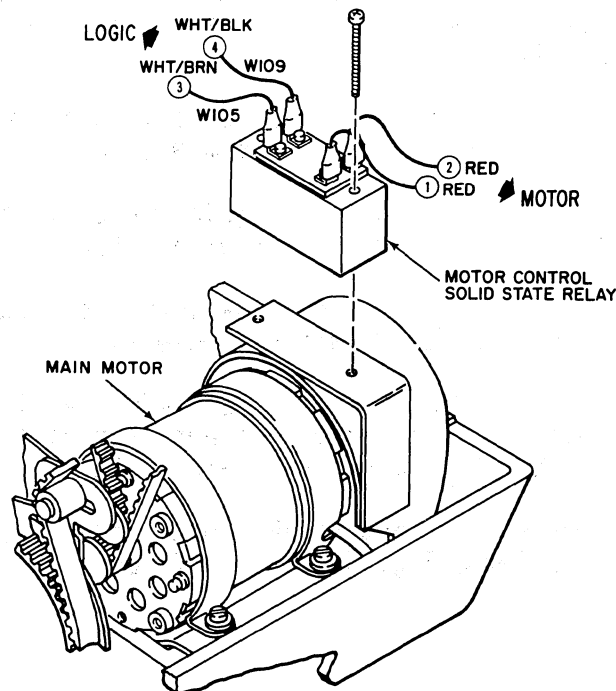

Figure 5-25. MOTOR CONTROL LOCATION AND INSTALLATION

## 5.2.20 VERTICAL FORMAT UNIT (VFU) - OPTION

5.2.20.1 Operation

The VFU tape movement is electro-mechanically controlled by a shaft coupled to the form feed mechanism (paper drive). The tape advances by one sprocket hole each time a line feed is performed. As a result, with both the tape and top of form properly aligned, any Top of Form command (TOF) will advance the paper to the Top of Form position. Similarly any Vertical Tab Code (VT) from the input data lines will advance the paper movement six lines or one inch (Centronics' standard VFU tape) (See para. 5.2.20.3 for paper tape reader (VFU) adjustments).

5.2.20.2 Removal/ReplacementA. VERTICAL FORMAT UNIT 63060125-5003 (FIGURE 8-20) AND (FIGURE 8-i/3)

Remove/replace tape reader assembly 63060125-5003, or -5002 (alternate) using kit no. 63060173-6002 from parts list shown in Figure 8-20.

1. Using a 1/16-in. (1.6 mm) allen wrench, loosen two 6-32 allen head screws (item 10 from kit) on right-hand coupling (item 11 from kit). Coupling is projecting to the left through right chassis frame, AI-1 on form feed shaft (BJ-37). (Refer to Fig. 5-26)
2. Using a 1/16-in. (1.6 mm) allen wrench, loosen two allen head screws (item 10 from kit) on left-hand coupling (item 11 from kit) located on shaft (Fig. 5-26 of VFU unit).
3. Remove the left and right couplings after removing connecting drive shaft (item 9 of kit).
4. Disconnect VFU connector (Fig. 8-20/19) from logic harness connector at back of printer.
5. Cut two cable ties (Fig. 8-20/29) located on back spacer rod (Fig. 8-20/7) holding cable ass'y (Fig. 8-20/18).
6. Remove the VFU assembly from left chassis frame (AI-12) by removing three nuts washers (kit part no.'s 5, 6, 8) from the VFU spacer rods (Fig. 8-20/7).
7. To replace or install VFU unit, reverse steps D.1. through D.5. and use Fig. 5-26 for reference.



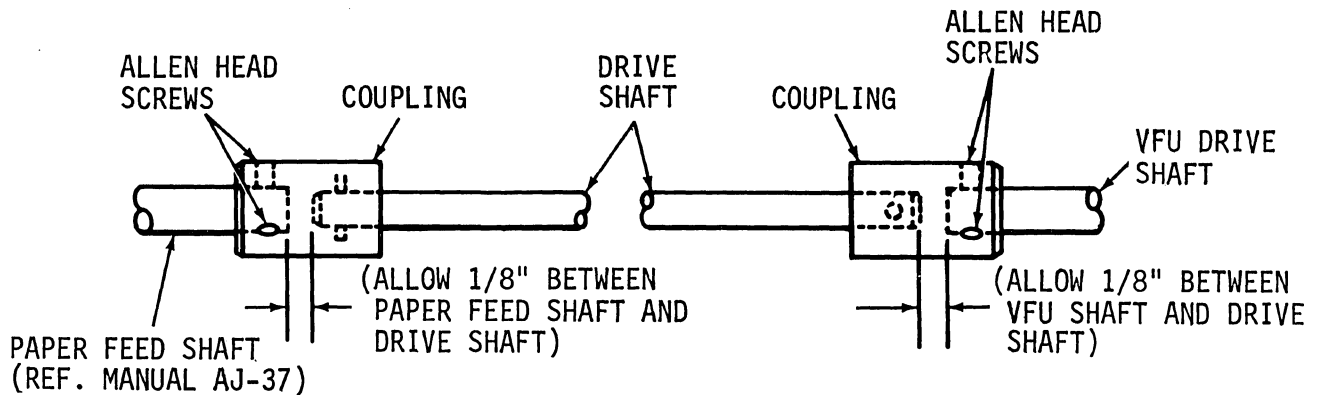

Figure 5-26. REMOVAL/REPLACEMENT OF DRIVE SHAFT 63060142-5001 AND COUPLINGS 63060144-2002 FOR VFU ASSEMBLY

### 5.2.20.3 Adjustments

#### A. PAPER TAPE READER ADJUSTMENT/MAINTENANCE (SEE FIG. 5-27)

The following procedure details the adjustment and maintenance for the alining of the paper tape holes with respect to the tape reader holes (infra red light source) in the lower vertical format unit.

1. Raise upper tape reader (Sensor) (Fig. 8-20/20) to expose paper tape containing channel holes and sprocket drive holes.
2. Loosen two set-screws on right-hand coupler on form feed shaft (Fig. 5-26).
3. Manually rotate drive shaft (Fig. 5-26) in a clockwise direction and observe the Top of Form (TOF) (channel 7) and the Vertical Tab (VT) hole (channel 5) as they move toward the rectangular slit holes on the lower tape reader (Fig. 5-27).
4. At the point where the leading edges of both the VT and TOF holes align with the front edges of the slits or light holes on the top of the lower tape reader, stop turning the shaft. (Fig. 5-27)
5. Tighten screws on the right coupler loosened in para. A.2. above.

6. When testing for Top of Form (TOF) alignment, in relation to the print out on the paper form, make sure that the form does not stop one line before, or one line beyond TOF position. Repeat steps A.1. through A.5. to re-align, if required.

Note

*Pressing Top of Form switch on operator panel allows hole on paper tape to move over the light source. Sensing the light source through the paper tape hole by the upper tape reader holes immediately stops tape motion.*

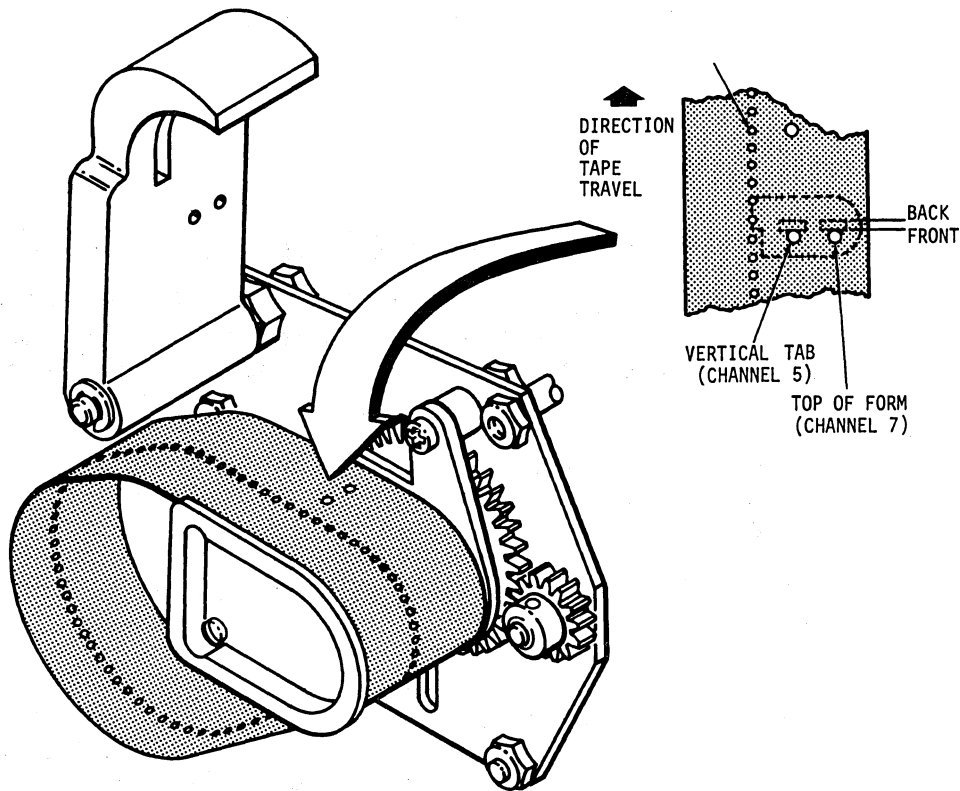

Figure 5-27. PAPER TAPE READER ADJUSTMENT

### 5.2.21 PRINTER DRIVE MECHANISM, MODEL 306

The overall drive mechanism of the Model 306 is shown in Figure 5-28. The name of the part or assembly is keyed to the parts list along with the reference symbol number that can be used for a cross reference to any figure number in Section 8 for that part.

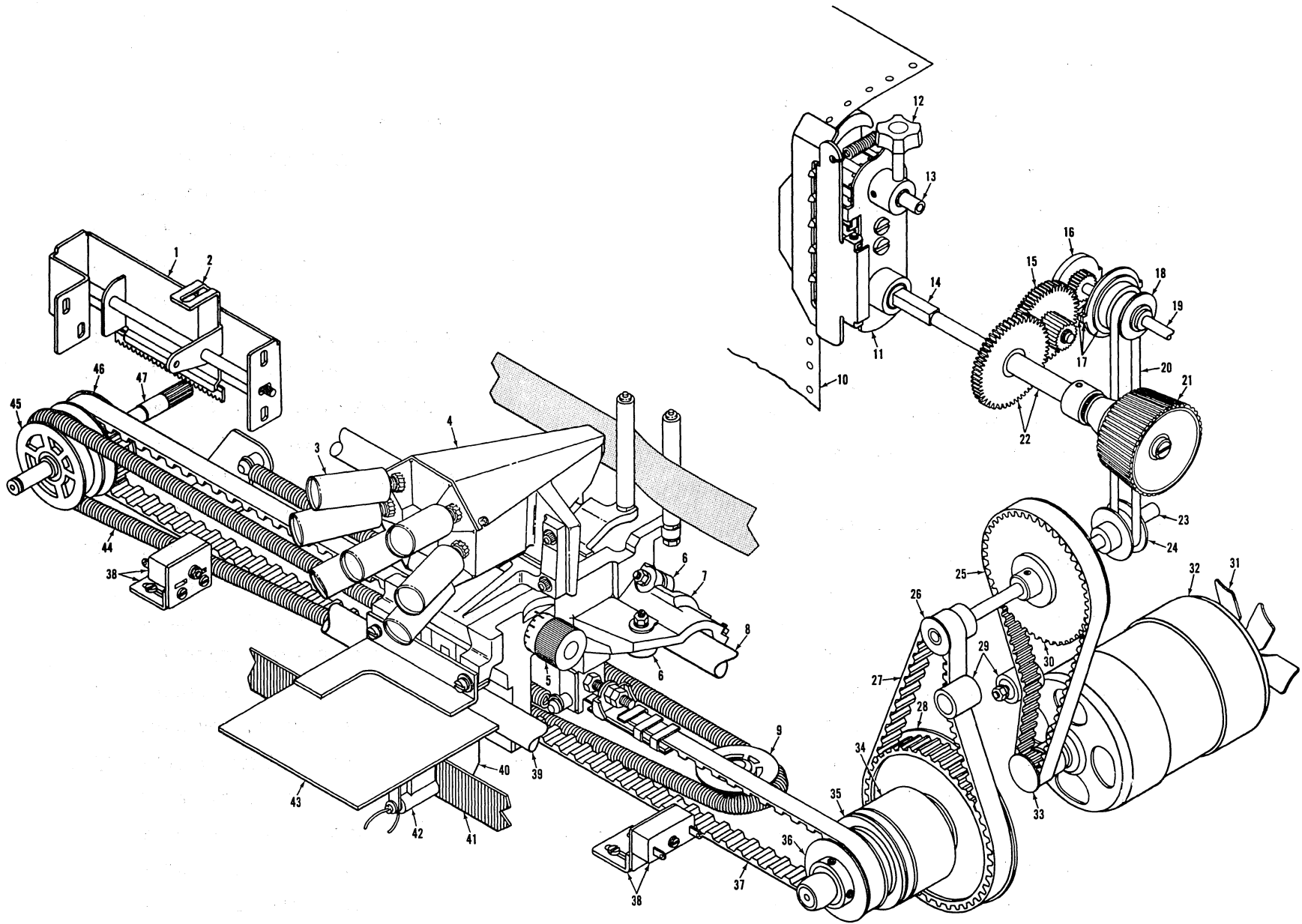

Figure 5-28. PRINTER DRIVE MECHANISM, MODEL 306

FIGURE 5-28. SUBASSEMBLY PARTS LIST, MODEL 306

Rev. E

5-56

1. RACK GUIDE PLATE (AL)
2. RIBBON FEED RACK (AL)
3. SOLENOID, PRINT HEAD (Fig. 8-19/10 and 15)
4. PRINT HEAD Fig. 8-19/13
5. HEAD ADJUSTING KNOB (Fig. 8-19/22)
6. CARRIAGE ROLLER (AA)
7. CARRIAGE (AA)
8. CARRIAGE GUIDE BAR, REAR (AA)
9. RETURN IDLER PULLEY AND BRACKET (AG)
10. MULTI-FORM PAPER
11. PIN FEED ASSEMBLY (AK)
12. FIXING KNOB (AK)
13. PAPER FEED GUIDE SHAFT (AI)
14. PAPER FEED SHAFT (AI)
15. PAPER FEED IDLER GEAR (AJ)
16. PAPER FEED CAM (AJ)
17. CLUTCH, INNER CAM, RELEASER, AND PAWL
18. CLUTCH PULLEY (AJ)
19. CLUTCH SHAFT (AJ)
20. O-RING (AJ)
21. PLATEN KNOB (AJ)
22. PAPER FEED GEAR (AJ)
23. CENTER SHAFT (AD - PART 1)
24. DRIVING PULLEY (AD - PART 1)
25. TIMING BELT (140-L, AD - PART 1)
26. MOTOR PULLEY (AD-PART 1)
27. TIMING BELT (150-L, AD - PART 1)
28. DRIVING PULLEY (AE-1, PART 2)
29. TENSIONER (L) (AD - PART 1)
30. CENTER PULLEY (AD - PART 1)
31. MOTOR FAN (AD - PART 1)
32. MOTOR (110V, 60Hz) OR OPTIONAL 220V, 50Hz (AD-1, PART 1)
33. MOTOR PULLEY (AD - PART 1)
34. ELECTROMAGNETIC CLUTCH UNIT AND ROTOR (AE)
35. CLUTCH ARMATURE (AE)
36. DRIVING PULLEY (C) (AE)
37. MAIN DRIVE BELT UNIT (AE)
38. REED SWITCH AND BRACKET (AG)
39. FRONT CARRIAGE BAR (AA)
40. FIBRE OPTICS HEAD (8-19/8)
41. TIMING FENCE (AB)
42. LAMP ASSEMBLY (FIG. 8-19/41)
43. VIDEO AMPLIFIER ASS'Y (FIG. 8-19/26)
44. CARRIAGE SPRING (AG)
45. RETURN PULLEY (AF)
46. IDLE PULLEY AND SAFETY ADJUST (AF)
47. IDLE PULLEY SHAFT (PINION) (AE)

SECTION 6  
MAINTENANCE

This section contains the following maintenance information:

<u>Paragraph</u>	<u>Description</u>
6.1	Electrical Adjustments
6.2	Preventive Maintenance
6.3	Troubleshooting Guide
6.4	Recommended Tools

In addition, detailed removal, replacement and adjustment procedures for all mechanical assemblies are contained in Section 5. Associated mechanical drawings and list of materials are in Section 8. Detailed theory of operation on the electronics portion is contained in Section 4 and associated drawings and lists of materials are in Section 7.

6.1 ELECTRICAL ADJUSTMENTS

All electrical adjustments located on the Logic/Power Supply board (63060104) are summarized in the following table. All mechanical adjustments are described in detail in Section 5.

<u>Item No.</u>	<u>Function</u>	<u>Signal Name</u>	<u>Element-Pin</u>	<u>Adj. Resistor</u>	<u>Pulse Width</u>
1	Video Strobe Pulse	STROBE	ME23-6*	R25	500 <sup>+</sup> 25 usec
2	Strobe Delay Interval	-	ME28-4	R31	600 usec
3	Delayed Strobe Pulse	DLYSTB	ME28-5	R33	500 <sup>+</sup> 25 usec
4	Single Line Feed Pulse	LF	ME32-13	R20	15 msec
5	Double Line Feed Pulse (Optional)	LF	ME32-13	R82	50 msec

\*ME23-6 signifies element ME23, pin 6.

## 6.2 SERIES 300 PREVENTIVE MAINTENANCE

The following Preventive Maintenance (PM) procedures apply to the Series 300 printers.

FREQUENCY OF P.M.	-	6 MONTHS
TIME REQUIRED	-	1 HOUR (APPROXIMATELY)
CLEANING MATERIAL	-	TWO SOFT CLEAN CLOTHS MEDIUM BRISTLE CLEANING BRUSH

### RECOMMENDED TOOLS

Refer to Section 6.4 of the Maintenance Section.

### LUBRICANTS RECOMMENDED:

Lightweight Oil (choice of three):

- 1) Teilus No. 27 (Shell), CDCC Spec No. 30050005.
- 2) Teresso No. 43 (Esso), CDCC Spec. No. 30050006.
- 3) Vaculine No. 1405 (Mobil), CDCC Spec. No. 30050007.

### Grease

Rheolube - No. 723 ms, CDCC Spec. No. 30050004

### Oil

Anderol No. 465, CDCC Spec No. 30050002

### PREPARATION

1. Obtain print sample prior to beginning of P.M.
2. Clean printer with vacuum cleaner, if available.

## 1. CARRIAGE ASSEMBLY AND TIMING FENCE

- a) Using a soft clean cloth, wipe both sides of timing fence. If necessary, use a mild detergent. (See Figure 1)

**CAUTION:** NEVER USE AN ORGANIC SOLVENT, AS THIS WILL DAMAGE TIMING FENCE.

- b) Wipe the carriage guide bars, all rollers and platen.  
c) Lightly lubricate guide bars using lightweight oil (See Figure 1).  
d) Remove print head from carriage.  
e) Using an eye loupe, verify that print wires align flush with face of print head jewel. (Make sure that print wires are not recessed in the jewel). (See Figure 1)  
f) Re-mount print head on carriage assembly.

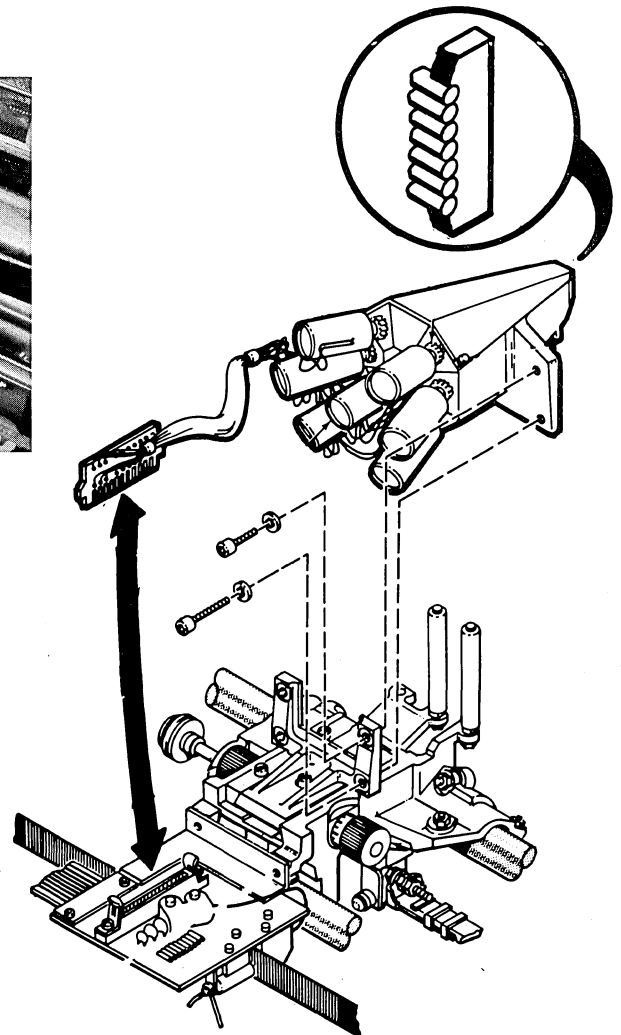
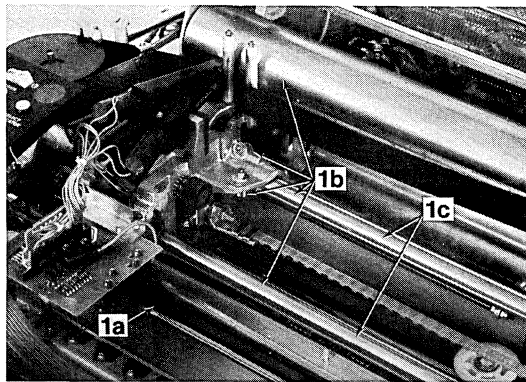

1d-1f

Figure 1. CARRIAGE ASSEMBLY AND TIMING FENCE

## 2. PAPER FEED ASSEMBLY

- a) Apply a drop of lightweight oil on the paper feed clutch gear and sliding shaft of the solenoid armature. (Oil is intended for clutch bearing lubrication). (See Figure 2)

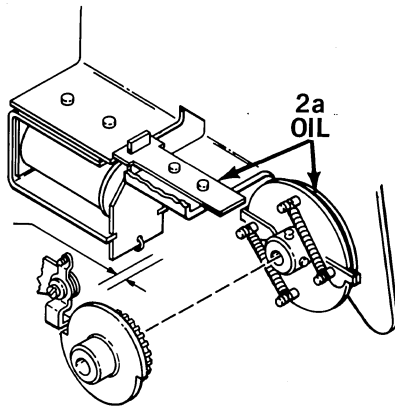

Figure 2. PAPER FEED ASSEMBLY

## 3. RIBBON FEED ASSEMBLY

- a) Inspect ratchets, pawls, and springs for wear and mesh (left and right).
- b) Clean and lubricate all gears and springs with grease and oil as indicated. (See Figure 3)
- c) Verify that both ribbon spools rotate freely when both ribbon releasers are in neutral position (neither spool engaged).

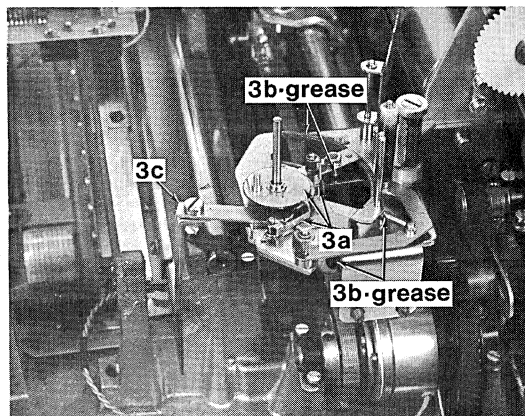

Figure 3. RIBBON FEED ASSEMBLY



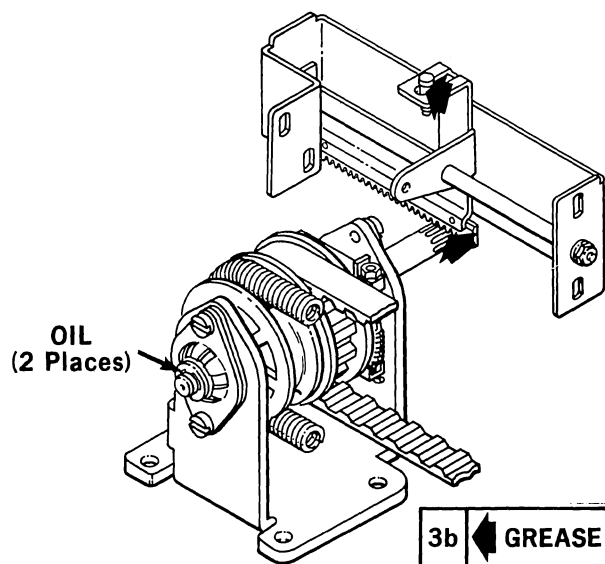

Figure 3. RIBBON FEED ASSEMBLY

#### 4. DRIVE ASSEMBLY

- a) Inspect gears for proper mesh and wear.
- b) Oil felt tensioner washers. (See Figure 4)

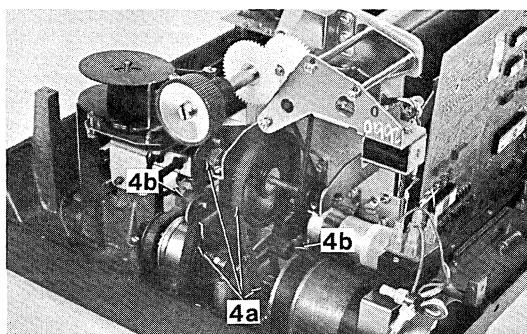

Figure 4. DRIVE ASSEMBLY

# SERIES 306 TROUBLESHOOTING GUIDE

## 306 PRINTER SERVICE GUIDE

The following information is intended to aid service personnel to develop good service procedures and troubleshooting techniques in servicing Centronics Model 306 printer.

When servicing the printer for any reason, a brier inspection and verification of the printer areas described below may well prevent potential failures in the future.

To perform this inspection, first remove the printer covers. Then, with printer power turned off, check the following areas:

1. Verify that the timing fence is clear and that a proper gap exists between the optics and the timing fence.
2. Verify that the carriage guide bar is clean and free of caked-on dirt.
3. Verify proper main drive belt tension.
4. Verify smooth, free carriage motion.
5. Check damper operation. Verify that there is no binding and that the piston O-ring is intact and lightly greased.
6. Check that the RTP and EOP switches are not loose.
7. Check that the line feed O-ring and pulleys are clean and do not slip.
8. Verify uniform clutch gap.
9. Verify proper pin alignment on pin-feed tractor units.
10. Verify proper pin feed belt tension.
11. Verify proper backstop pawl spring tension.
12. Verify smooth line feed clutch operation.

Turn power on:

If optional Vertical Format Unit is used, check VFU paper tape position over the light holes to insure proper detection of vertical tab and form feed signals.

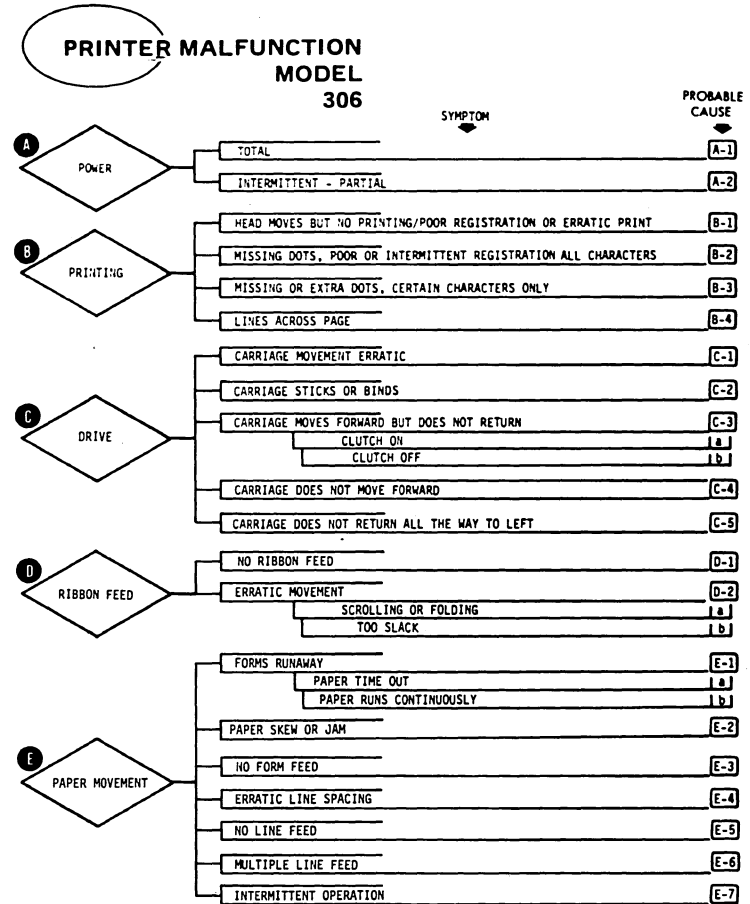

**A. POWER**

**A-1 TOTAL**

1. Damaged power card.
2. Open AC line fuse.
3. Open 5V supply fuse, F1.

**A-2 INTERMITTENT - PARTIAL**

1. Defective +5V logic board.
2. Defective +12V logic board.
3. Improper AC line voltage.

**B. PRINTING**

**B-1 HEAD MOVES BUT NO PRINT/POOR REGISTRATION OR ERRATIC PRINT**

1. Improper print head position.
2. Dirty fingerboards or circuit board connectors.
3. Dirty or defective timing fence.
4. Improper adjustment of optic bundle.
5. Improper optic lamp filament alignment.
6. Defective optic lamp or lamp socket.
7. Improper alignment of timing fence to optic slit.
8. Defective video amplifier.
9. Defective ribbon cable.
10. Defective +5V logic board.
11. Defective +12V logic board.
12. Defective driver board.

**B-2 MISSING DOTS, POOR OR INTERMITTENT PIN REGISTRATION, ALL CHARACTERS**

1. Improper print head position.
2. Dirty fingerboards or circuit board connectors.
3. Dirty or defective timing fence.
4. Improper damper piston and cylinder alignment.
5. Defective RTP or EDP switch.
6. Defective logic board fuses.
7. Improper optical system alignment.
8. Defective video amplifier.
9. Defective ribbon cable.
10. Defective driver board.
11. Improperly adjusted or defective print wire solenoids.

**B-3 MISSING OR EXTRA DOTS, CERTAIN CHARACTERS ONLY**

1. Defective ROM.
2. Defective P.C. runs in character generator.

**B-4 LINES ACROSS PAGE**

1. Improperly installed print head cover.

2. Improper penetration adjustment.
3. Defective print wires.
4. Defective ribbon cable.
5. Poor logic board to driver board connection.
6. Defective driver board.
7. Defective logic board.

**C. DRIVE**

**C-1 CARRIAGE MOVEMENT ERRATIC**

1. Improper clutch gap.
2. Improper main drive belt tension.
3. Dirty carriage guide bar.
4. Improper penetration adjustment.
5. Improper ribbon drive rack and pinion adjustment.
6. Improper cylinder and damper piston alignment.
7. Defective or improperly adjusted drive pulleys, gears or belts.

**C-2 CARRIAGE STICKS OR BINDS**

1. Fiber optics bundle touching timing fence.
2. Improper drive belt tension.
3. Improper damper piston and cylinder alignment.
4. Improper ribbon drive rack and pinion adjustment.
5. Right hand ribbon drive assembly driving pawl may have dropped behind ribbon releaser.

**C-3 CARRIAGE MOVES FORWARD BUT DOES NOT RETURN**

**C-3a Clutch On**

1. Defective E.O.P switch.
2. Defective driver board.
3. Defective logic board.

**C-3b Clutch Off**

1. Defective return spring.
2. Improper ribbon drive rack and pinion adjustment.
3. Defective ribbon drive assembly driving pawl.
4. Improper clutch gap.

**C-4 CARRIAGE DOES NOT RETURN ALL THE WAY TO LEFT**

1. Improper damper piston and cylinder alignment.
2. Improper ribbon drive rack and pinion adjustment.

**C-5 CARRIAGE DOES NOT MOVE FORWARD**

1. Improper damper piston and cylinder alignment.
2. Improper clutch gap.
3. Defective -12V supply fuse, F3.

4. Dirty board contacts.
5. Defective driver board.
6. Defective RTP switch.
7. Defective clutch.
8. Defective logic boards.
9. Defective drive motor.
10. Defective motor control circuitry (if provided).
11. Inappropriate input data.

**D. RIBBON FEED**

**D-1 NO RIBBON FEED**

1. Improperly seated ribbon spool.
2. Improperly adjusted ribbon reversing rod.
3. Rack and pinion assembly teeth missing.
4. Broken or missing ribbon drive pawl (see C-2 item 5).

**D-2 ERRATIC MOVEMENT**

**D-2a Scrolling or Folding**

1. Improperly mounted ribbon holding bracket.
2. Bent reversing arm or tensioner.

**D-2b Too Slack**

1. Missing or weak ribbon holding plate springs.
2. Broken or missing ribbon stop pawl.

**E. PAPER MOVEMENT**

**E-1 FORMS RUNAWAY**

**E-1a Paper Timeout**

1. Defective VFU lamp or sensor.
2. Defective paper tape.
3. Defective logic boards.
4. Improper alignment of reader bracket lamps to tape holes.
5. Improper gap between upper and lower VFU reader brackets.
6. Printer receiving form feed or vertical tab commands with no VFU installed.

**E-1b Paper Runs Continuously**

1. Defective armature return spring.
2. Solenoid slide movement restricted.
3. Excessive solenoid slide gap.
4. Restricted armature movement.

5. Defective driver board.
6. Defective logic boards.

**E-2 PAPER SKEW OR JAM**

1. Print head too close to paper.
2. Incorrect paper feed.
3. Improper pin feed sprocket alignment.
4. Improper pin feed belt tension.
5. Paper pan friction against forms.
6. Pin feed holder paper thickness setting too small.

**E-3 NO FORM FEED**

1. Improper gear train adjustment.
2. Paper feed o-ring slipping.
3. Defective TOP OF FORM switch or contacts.
4. Defective driver board.
5. Defective line feed solenoid fuse, F7.
6. Defective logic boards.
7. Improperly adjusted platen knob.

**E-4 ERRATIC LINE SPACING**

1. Excessive back stop pawl and cam mechanism play.
2. Backlash in platen knob.
3. Improper gear mesh.
4. Paper feed o-ring slipping.

**E-5 NO LINE FEED**

1. Defective or missing platen knob.
2. Improper solenoid slide gap.
3. Paper feed o-ring broken or slipping.
4. Defective driver board.
5. Defective line feed fuse, F7.
6. Defective logic boards.
7. Solenoid slide binding.
8. Armature binding.
9. Excessive solenoid armature spring tension.
10. Defective solenoid.
11. Defective LINE FEED switch or contacts.
12. Improperly adjusted drive train.

**E-6 MULTIPLE LINE FEED**

1. Excessive solenoid slide gap.
2. Defective armature return spring.
3. Magnetic field concentrating disc missing.
4. Solenoid slide binding.
5. Excessive line feed pulse width.
6. Excessive lubricant on or dirty solenoid slide.







**E-7 INTERMITTENT OPERATION**

1. See E-3 and E-5.

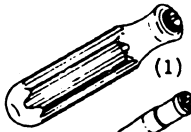
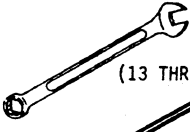
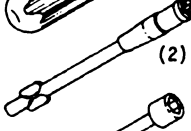
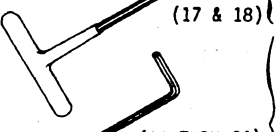
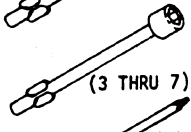
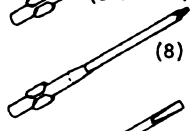
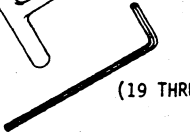
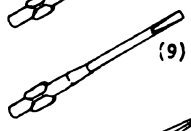
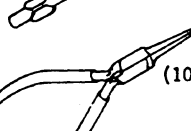
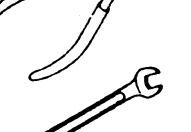
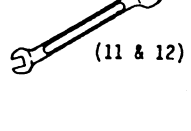
6.4 RECOMMENDED TOOLS

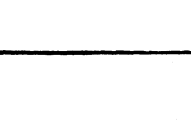
**CENTRONICS**  
data computer corp.  
MURKIN, NEW HAMPSHIRE U.S.A.

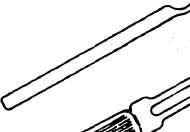
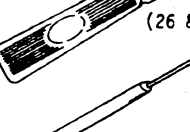
**CENTRONICS TOOL KIT**  
(63002399-6001)

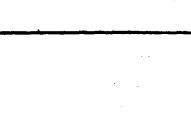
ITEM	DESCRIPTION	PART NUMBER	ITEM	DESCRIPTION	PART NUMBER
 (1)	1. Universal Handle	30600002-3001	 (13 THRU 16)	13. 8 mm Combination Open End, Box Wrench	30600002-3012
 (2)	2. Extension 4-Inch	30600002-3002	 (17 & 18)	14. 10 mm Combination Open End, Box Wrench	30600002-3013
 (3 THRU 7)	3. 4 mm Nut Driver	30600002-3003		15. 17 mm Combination Open End, Box Wrench	30600002-3014
 (8)	4. 5.5 mm Nut Driver	30600002-3004	 (19 THRU 24)	16. 19 mm Combination Open End, Box Wrench	30600002-3015
 (9)	5. 7 mm Nut Driver	30600002-3005		17. 3/32-Inch "T" Handle Hex Key	30600002-3016
 (10)	6. 8 mm Nut Driver	30600002-3006	18. 5/32-Inch "T" Handle Hex Key	30600002-3017	
 (11 & 12)	7. 10 mm Nut Driver	30600002-3007	19. 1/16-Inch Hex Key	30600002-3025	
 (8)	8. Phillips Head Screwdriver	30600002-3008	20. .050-Inch Hex Key	30600002-3024	
 (9)	9. Slotted Head Screwdriver	30600002-3009	21. 1.5 mm Hex Key	30600002-3020	
 (10)	10. Needle Nose Plier	30600002-3010	22. 2.0 mm Hex Key	30600002-3019	
 (11 & 12)	11. 5 x 5.5 mm Open End Wrench	30600002-3023	23. 2.5 mm Hex Key	30600002-3021	
	12. 6 x 7 mm Open End Wrench	30600002-3011	24. 3.0 mm Hex Key	30600002-3022	
			 (25)	25. Spanner Wrench	63003105-3001
			 (26 & 27)	26. 4 mm Snap Ring Holder	63002399-3018
			 (28)	27. 5 mm Snap Ring Holder	63002399-3019
			 (28)	28. Spring Hook	63002399-3020
			 (29)	29. Tool Pouch	30600002-3018

SECTION 7  
ELECTRICAL DRAWINGS AND LISTS OF MATERIALS

This section contains the schematic, wiring and assembly diagrams and lists of materials for all the electronic assemblies in the Model 306.



THE INFORMATION CONTAINED HEREIN IS PROPRIETARY AND IS NOT TO BE RELEASED OR REPRODUCED WITHOUT WRITTEN PERMISSION OF CENTRONICS data computer corp.

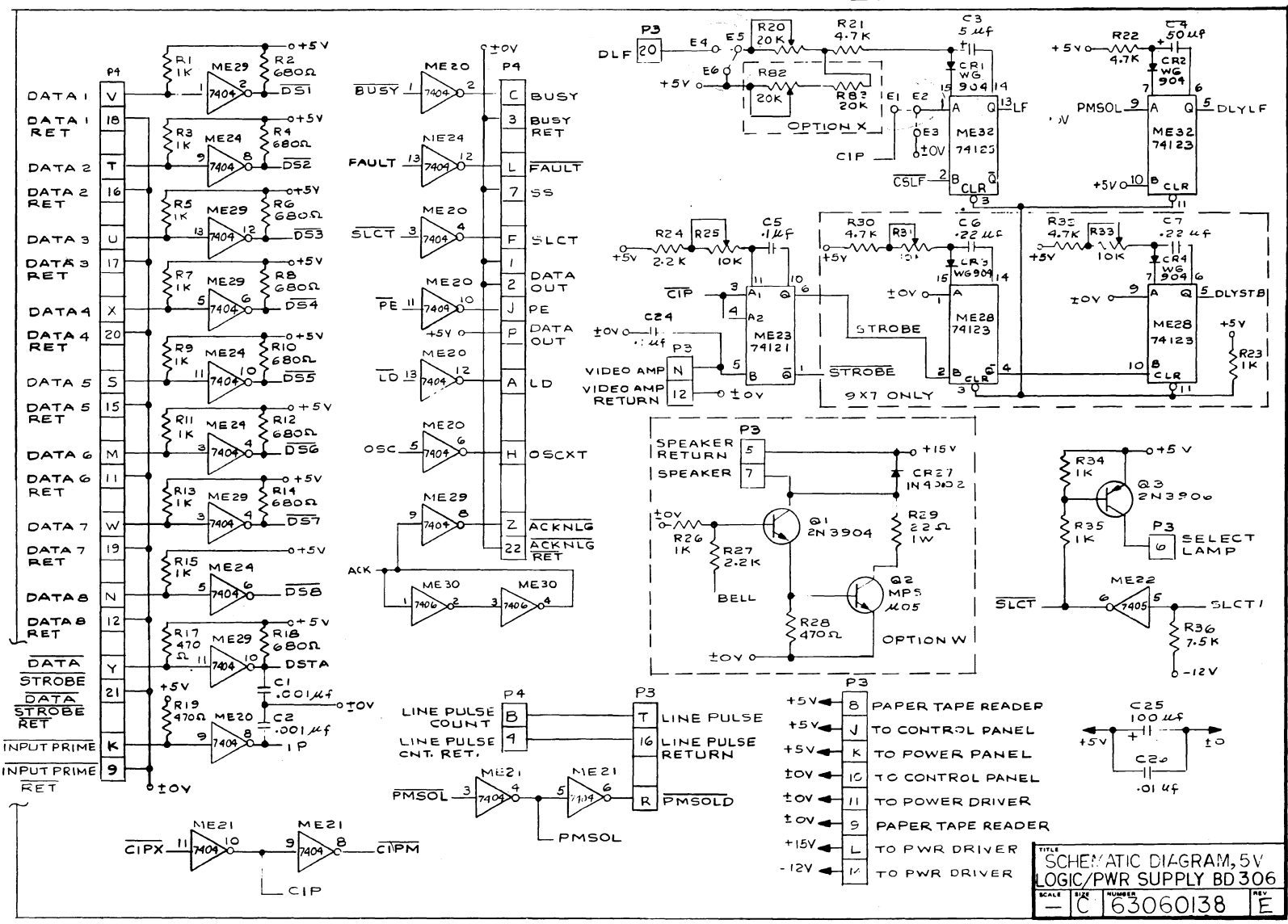

TITLE			
SCHEMATIC DIAGRAM, 5V LOGIC/PWR SUPPLY BD 306			
SCALE	SIZE	NUMBER	REV.
-	C	63060138	E

7-3

Rev. E

Figure 7-1. SCHEMATIC DIAGRAM, LOGIC/P.S. BOARD (+5V)

THE INFORMATION CONTAINED HEREIN IS PROPRIETARY AND IS NOT TO BE RELEASED OR REPRODUCED WITHOUT WRITTEN PERMISSION OF CENTRONICS data computer corp.

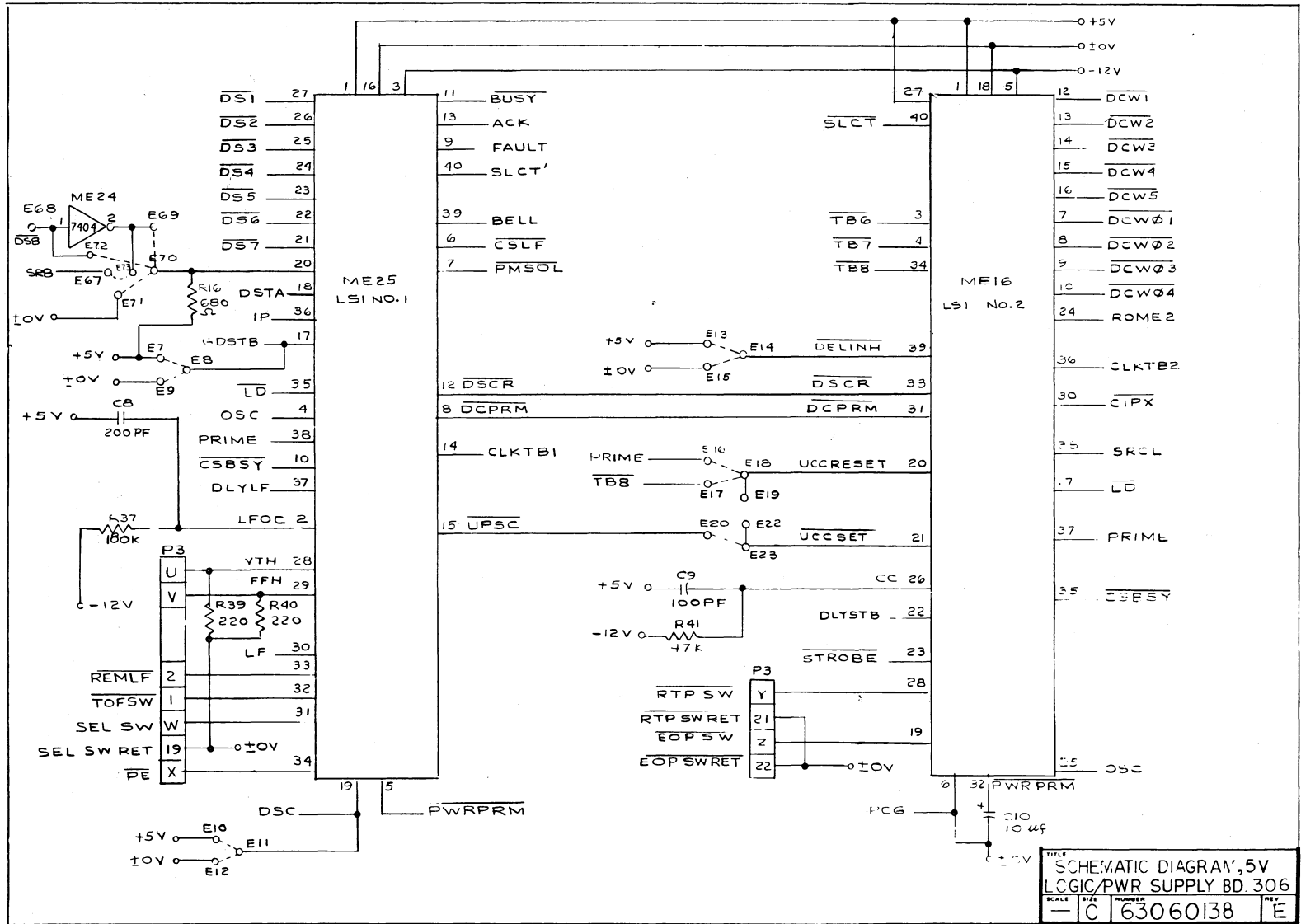
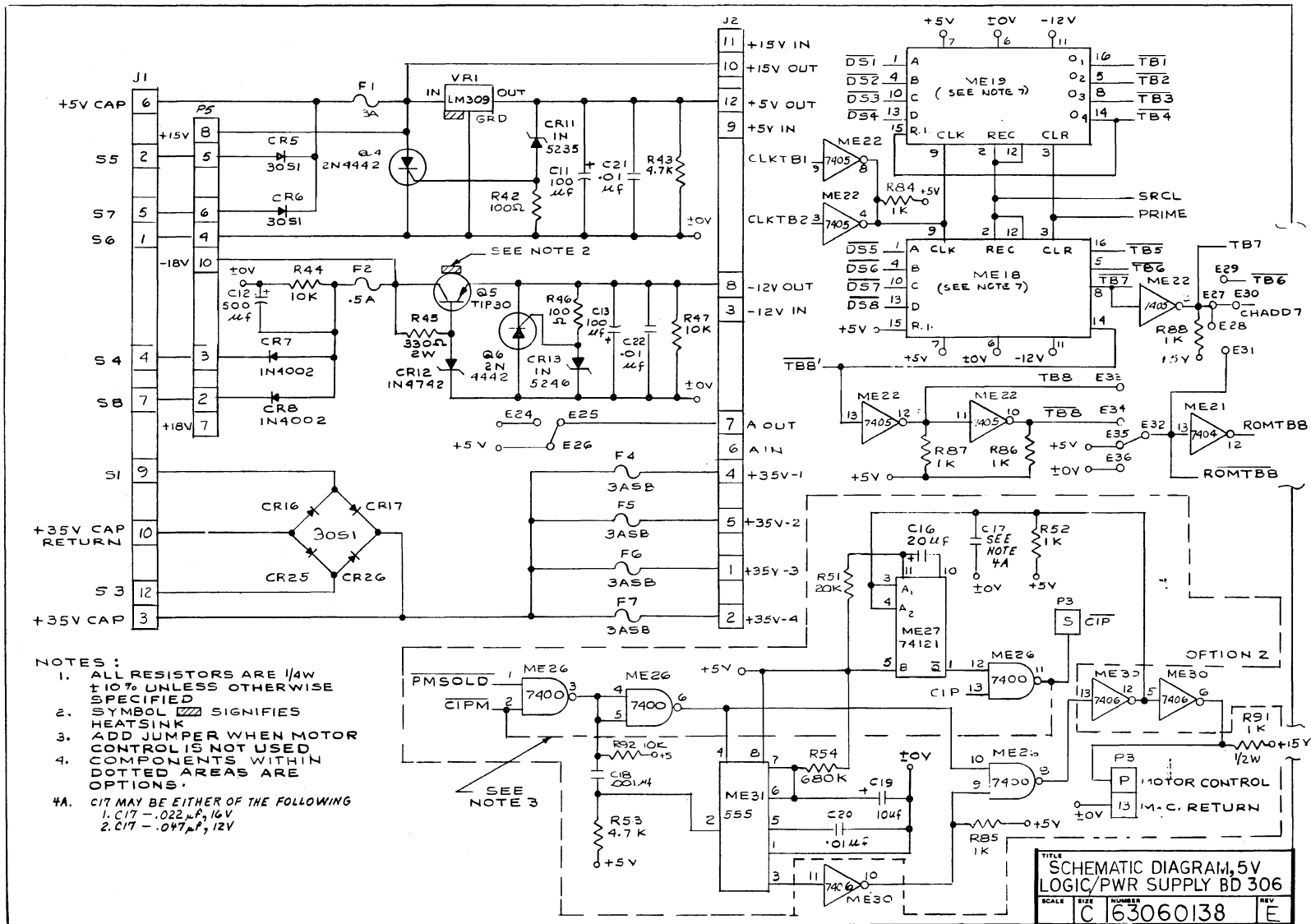

Figure 7-2. SCHEMATIC DIAGRAM, LOGIC/P.S. BOARD (+5V) (SHEET 2 OF 4)



THE INFORMATION CONTAINED HEREIN IS PROPRIETARY AND IS NOT TO BE RELEASED OR REPRODUCED WITHOUT WRITTEN PERMISSION OF CENTRONICS data computer corp.



- NOTES:
1. ALL RESISTORS ARE 1/4W ±10% UNLESS OTHERWISE SPECIFIED
  2. SYMBOL  SIGNIFIES HEATSINK
  3. ADD JUMPER WHEN MOTOR CONTROL IS NOT USED
  4. COMPONENTS WITHIN DOTTED AREAS ARE OPTIONS
- 4A. C17 MAY BE EITHER OF THE FOLLOWING  
 1. C17 - .022µF, 16V  
 2. C17 - .047µF, 12V

Figure 7-3. SCHEMATIC DIAGRAM, LOGIC/P.S. BOARD (+5V) (SHEET 3 OF 4)

THE INFORMATION CONTAINED HEREIN IS PROPRIETARY AND IS NOT TO BE RELEASED OR REPRODUCED WITHOUT WRITTEN PERMISSION OF CENTRONICS data computer corp.

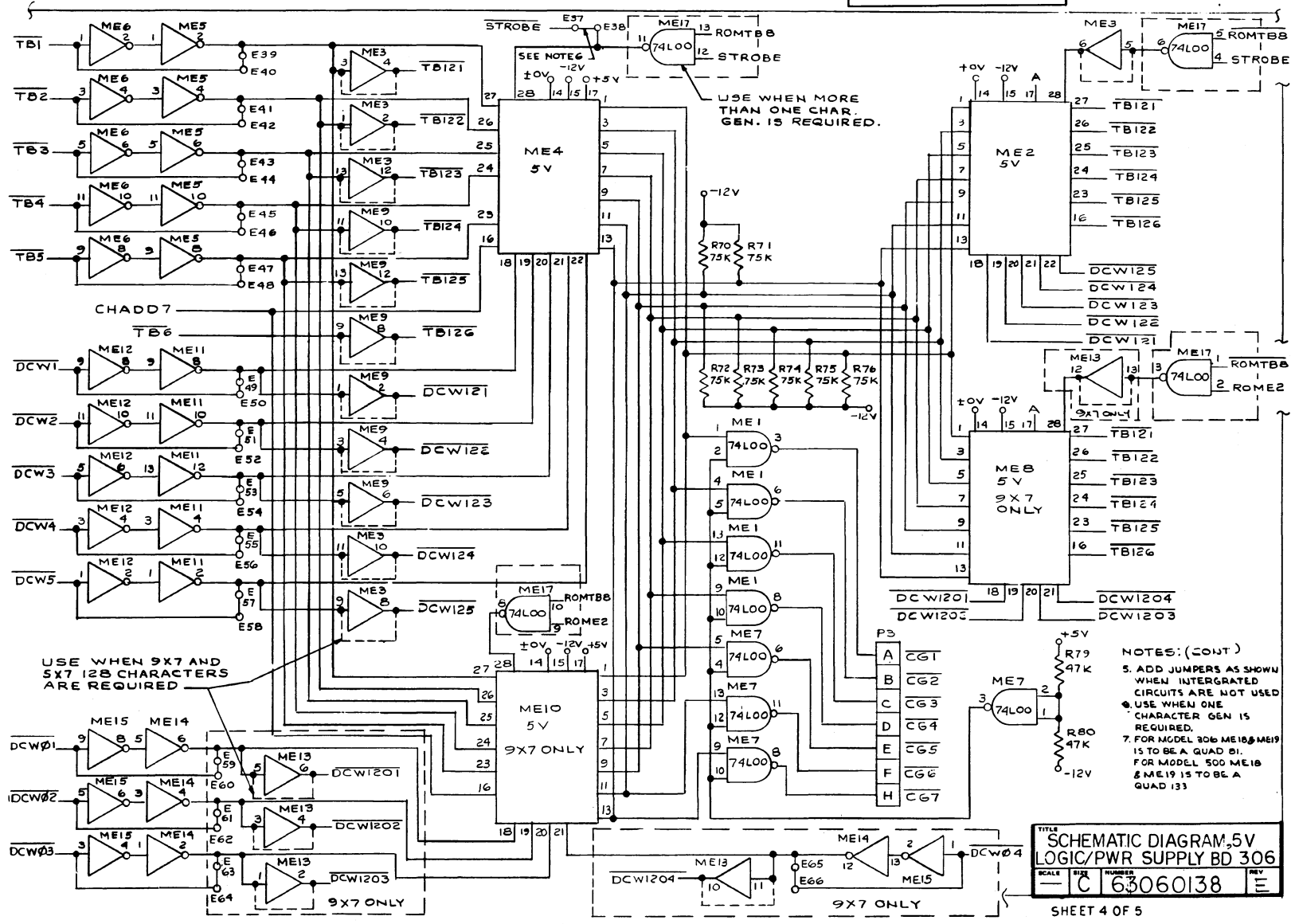

USE WHEN 9X7 AND 5X7 128 CHARACTERS ARE REQUIRED

USE WHEN MORE THAN ONE CHAR. GEN. IS REQUIRED.

- NOTES: (CONT.)
- 5. ADD JUMPERS AS SHOWN WHEN INTEGRATED CIRCUITS ARE NOT USED
  - 6. USE WHEN ONE CHARACTER GEN IS REQUIRED.
  - 7. FOR MODEL 306 ME10, ME19 IS TO BE A QUAD 01. FOR MODEL 500 ME10 & ME19 IS TO BE A QUAD 133

TITLE SCHEMATIC DIAGRAM, 5V LOGIC/PWR SUPPLY BD 306

SCALE	SIZE	NUMBER	REV
-	C	63060138	E

SHEET 4 OF 5

Figure 7-4. SCHEMATIC DIAGRAM, LOGIC/P.S. BOARD (+5V) (SHEET 4 OF 4)

THE INFORMATION CONTAINED HEREIN IS PROPRIETARY AND IS NOT TO BE RELEASED OR REPRODUCED WITHOUT WRITTEN PERMISSION OF CENTRONICS data computer corp.

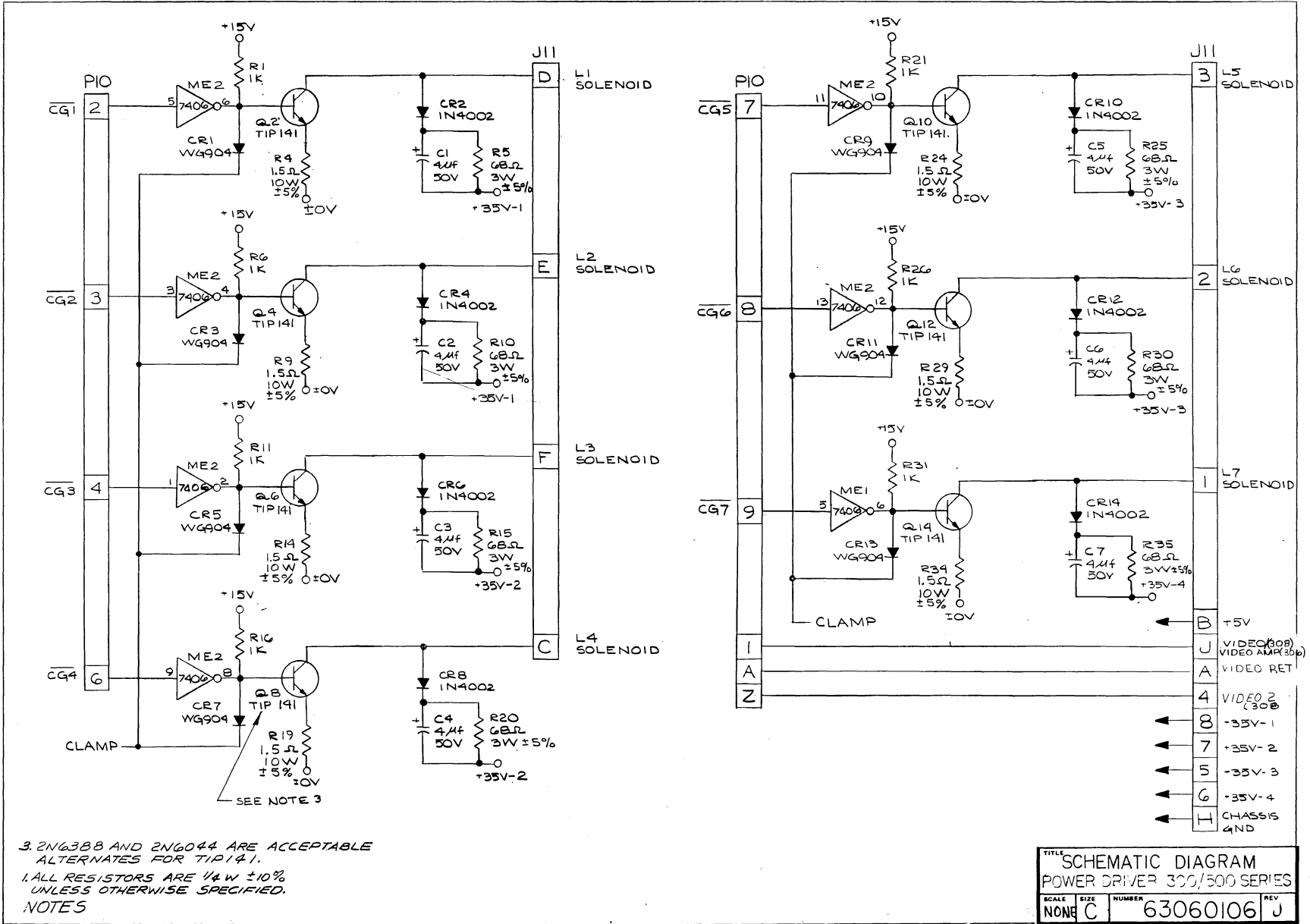

7-7

Rev. F

Figure 7-5. SCHEMATIC DIAGRAM, POWER DRIVER BOARD (SHEET 1 OF 2)

THE INFORMATION CONTAINED HEREIN IS PROPRIETARY AND IS NOT TO BE RELEASED OR REPRODUCED WITHOUT WRITTEN PERMISSION OF CENTRONICS data computer corp.

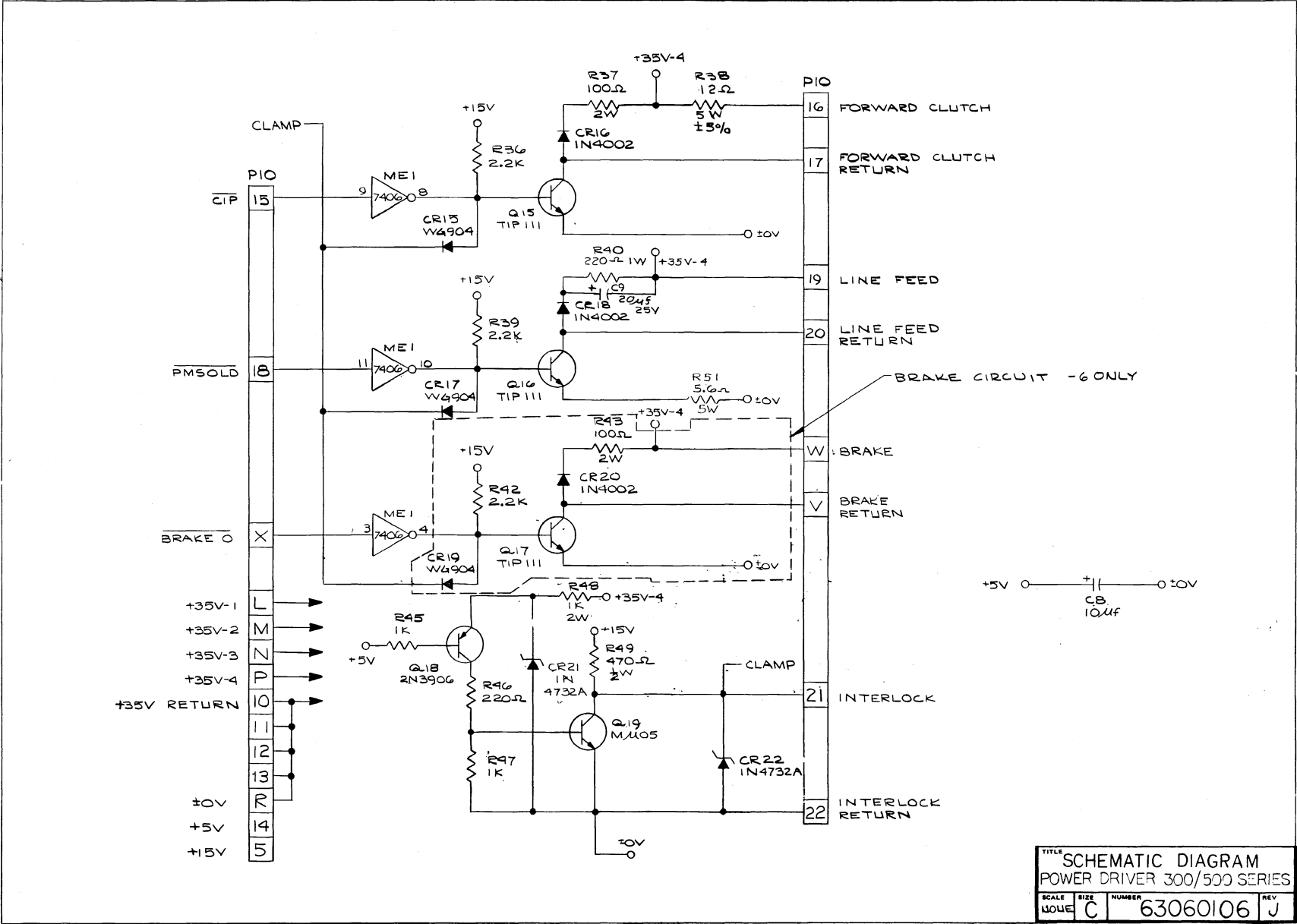

TITLE			
SCHEMATIC DIAGRAM			
POWER DRIVER 300/500 SERIES			
SCALE	SIZE	NUMBER	REV
130LIE	C	63060106	J

SHEET 2 OF 3

Figure 7-6. SCHEMATIC DIAGRAM, POWER DRIVER BOARD (SHEET 2 OF 2)

THE INFORMATION CONTAINED HEREIN IS PROPRIETARY AND IS NOT TO BE RELEASED OR REPRODUCED WITHOUT WRITTEN PERMISSION OF CONTRACTOR'S Data Computer Corp.

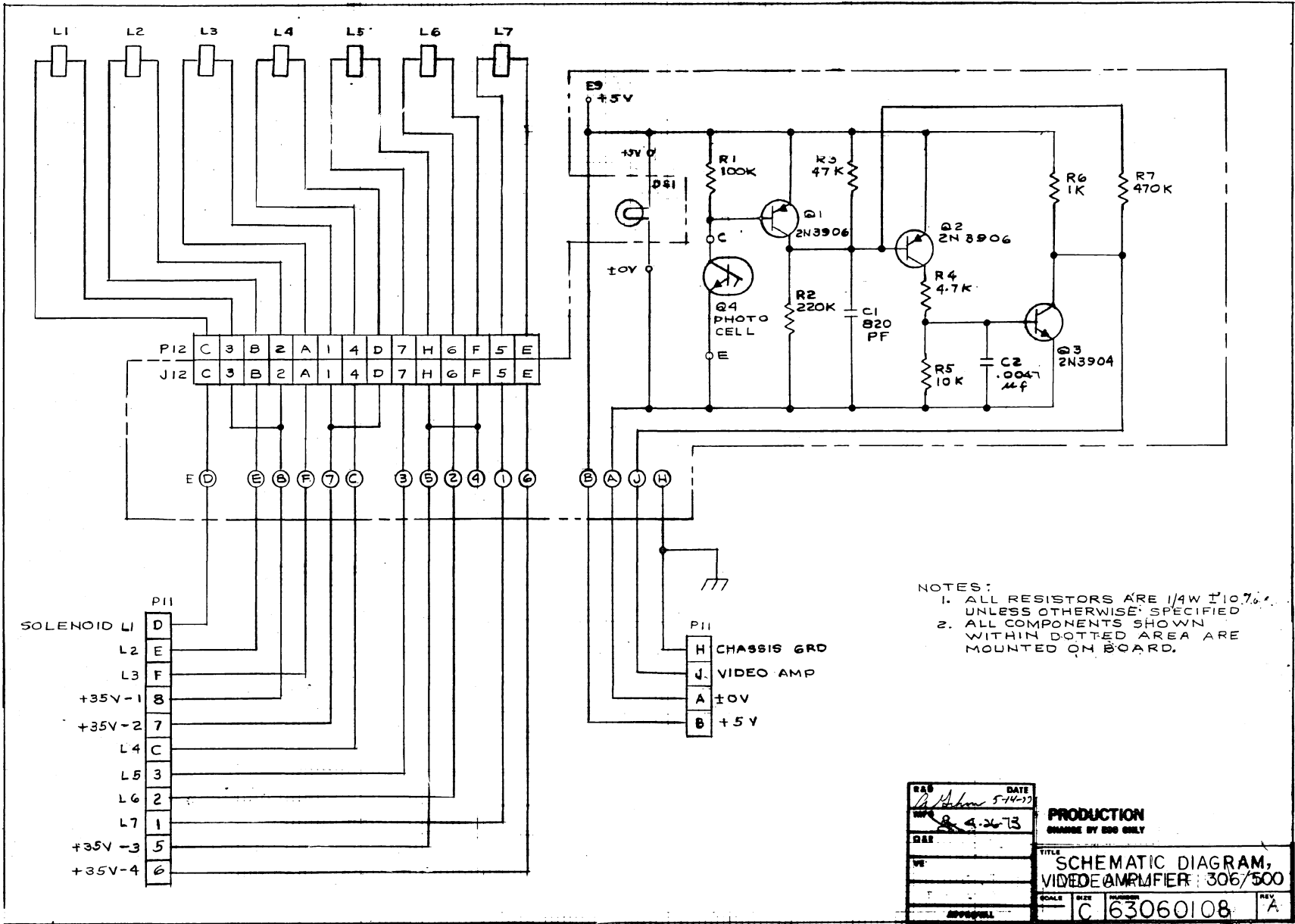

- NOTES:
1. ALL RESISTORS ARE 1/4W  $\pm 10.7\%$  UNLESS OTHERWISE SPECIFIED
  2. ALL COMPONENTS SHOWN WITHIN DOTTED AREA ARE MOUNTED ON BOARD.

DESIGNED BY	DATE	5-14-73
DRAWN BY	DATE	4-26-73
CHECKED BY		
APPROVED BY		
TITLE		
SCHEMATIC DIAGRAM, VIDEO AMPLIFIER: 306/500		
SCALE	REV	NO. 2
C		63060108
		REV A

Figure 7-7. SCHEMATIC DIAGRAM, VIDEO AMPLIFIER

7-9

Rev. F

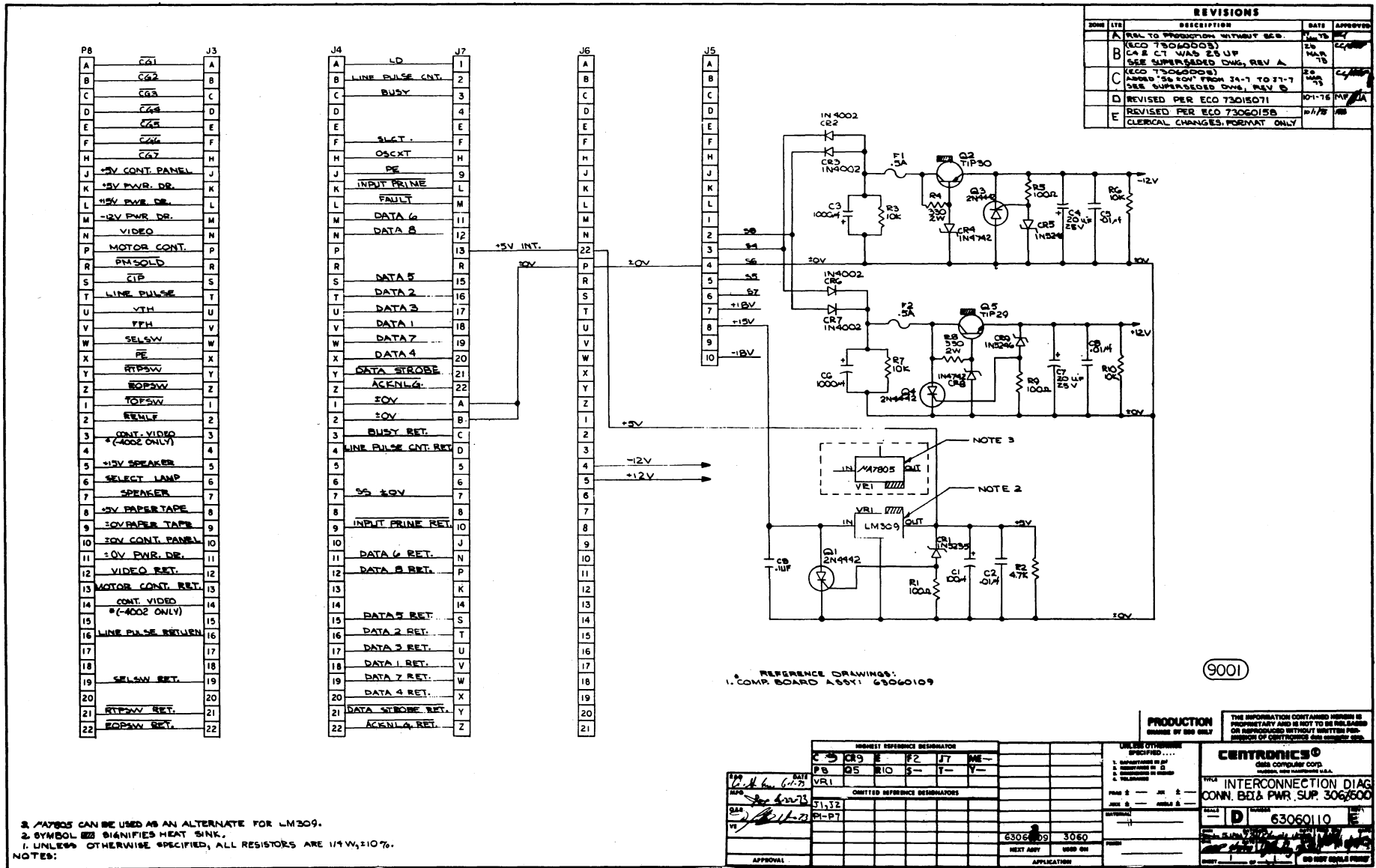

Figure 7-8. INTERCONNECTION DIAGRAM, CONNECTOR CARD

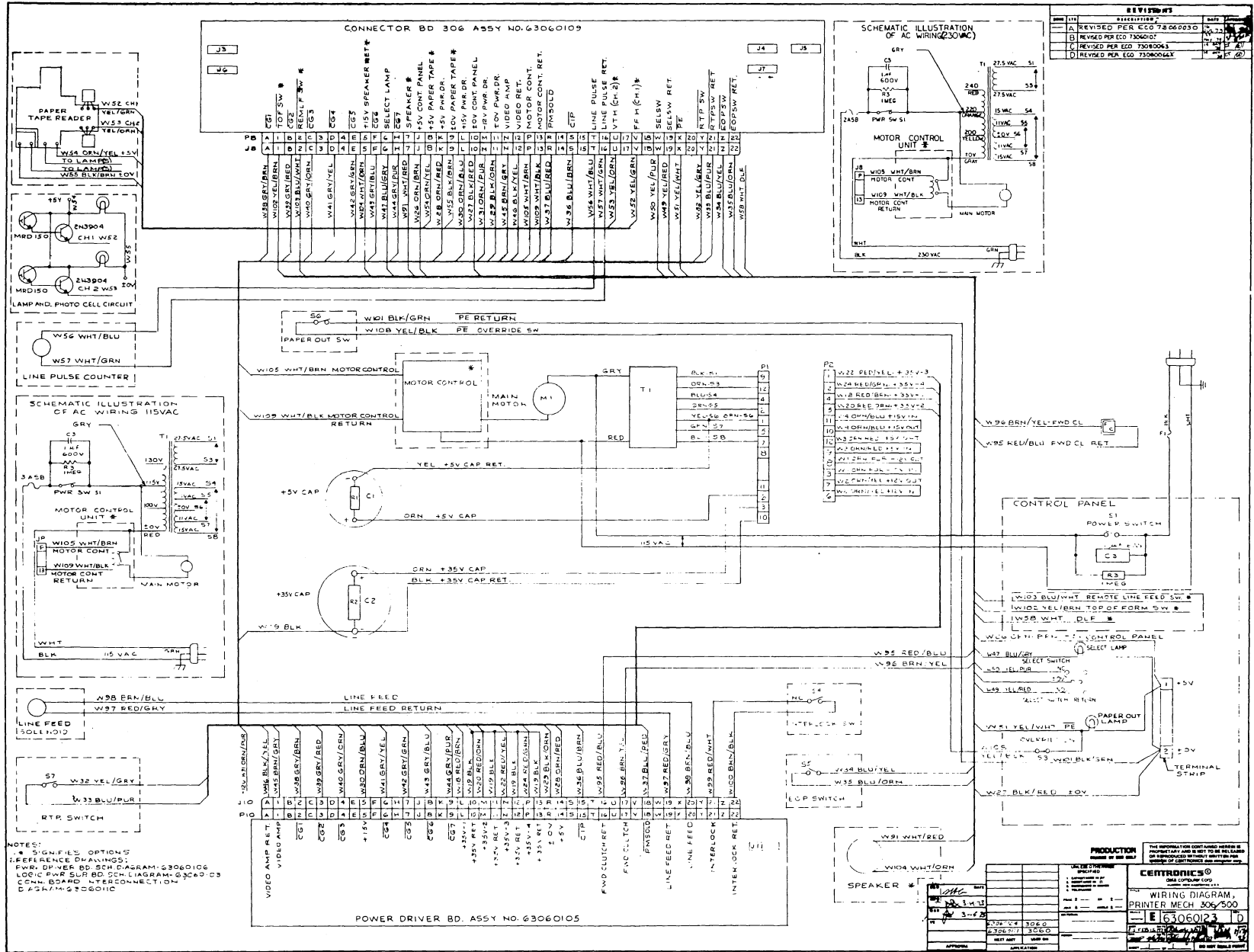
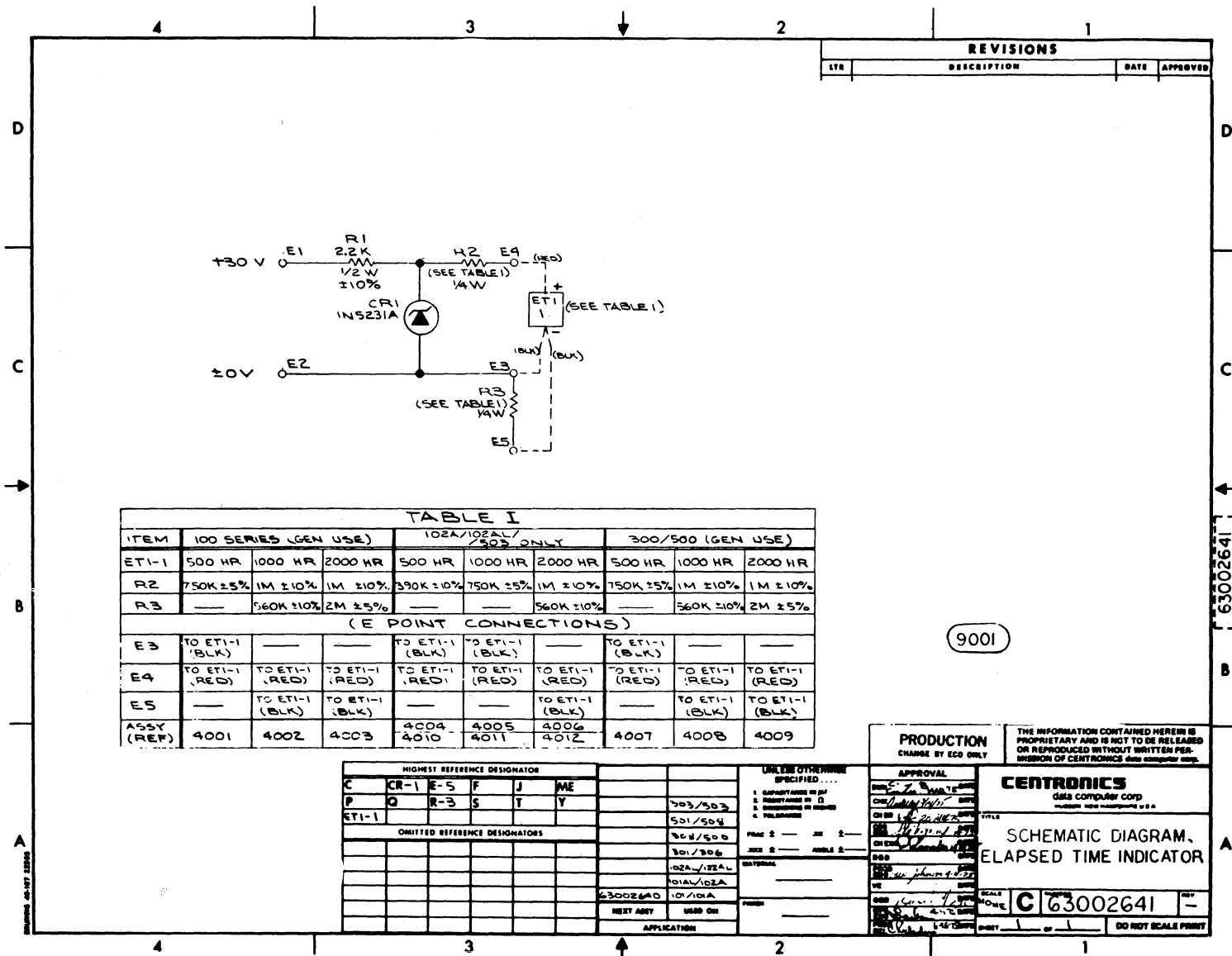

Figure 7-9. WIRING DIAGRAM, PRINTER MECHANISM



**TABLE I**

ITEM	100 SERIES (GEN USE)			102A/102AL/503 ONLY			300/500 (GEN USE)		
	500 HR	1000 HR	2000 HR	500 HR	1000 HR	2000 HR	500 HR	1000 HR	2000 HR
R2	750K ±5%	1M ±10%	1M ±10%	390K ±10%	750K ±5%	1M ±10%	750K ±5%	1M ±10%	1M ±10%
R3	—	560K ±10%	2M ±5%	—	—	560K ±10%	—	560K ±10%	2M ±5%

(E POINT CONNECTIONS)

POINT	TO ETI-1 (BLK)	TO ETI-1 (RED)	TO ETI-1 (BLK)	TO ETI-1 (RED)	TO ETI-1 (BLK)	TO ETI-1 (RED)	TO ETI-1 (BLK)	TO ETI-1 (RED)	TO ETI-1 (BLK)
E3	TO ETI-1 (BLK)	—	—	TO ETI-1 (BLK)	TO ETI-1 (BLK)	—	TO ETI-1 (BLK)	—	—
E4	TO ETI-1 (RED)	TO ETI-1 (RED)	TO ETI-1 (RED)	TO ETI-1 (RED)	TO ETI-1 (RED)	TO ETI-1 (RED)	TO ETI-1 (RED)	TO ETI-1 (RED)	TO ETI-1 (RED)
E5	—	TO ETI-1 (BLK)	TO ETI-1 (BLK)	—	—	TO ETI-1 (BLK)	—	TO ETI-1 (BLK)	TO ETI-1 (BLK)

ASSY (REF)	4001	4002	4003	4004	4005	4006	4007	4008	4009
------------	------	------	------	------	------	------	------	------	------

HIGHEST REFERENCE DESIGNATOR					
C	CR-1	E-5	F	J	ME
P	Q	R-3	S	T	Y
ETI-1					

OMITTED REFERENCE DESIGNATORS					

UNLESS OTHERWISE SPECIFIED . . . . .

- CAPACITANCE IN PF
- RESISTANCE IN Ω
- RESISTANCE IN KILOHMS
- RESISTANCE IN MEGOHMS

FRG 2 — JUL 2 —  
 JUL 2 — ANGLE 2 —

DATE: \_\_\_\_\_  
 TIME: \_\_\_\_\_

PREP: \_\_\_\_\_  
 CHECK: \_\_\_\_\_

APPROVAL: \_\_\_\_\_

**PRODUCTION**  
 CHANGE BY ECO ONLY

THE INFORMATION CONTAINED HEREIN IS PROPRIETARY AND IS NOT TO BE RELEASED OR REPRODUCED WITHOUT WRITTEN PERMISSION OF CENTRONICS data computer corp.

**CENTRONICS**  
 data computer corp  
 MILBURN, NEW HAMPSHIRE U.S.A.

**TITLE**  
 SCHEMATIC DIAGRAM, ELAPSED TIME INDICATOR

DATE: 10/11/67  
 DRAWN: [Signature]  
 CHECKED: [Signature]  
 APPROVED: [Signature]

SCALE: NONE  
 PART: C 63002641  
 SHEET: 1 OF 1  
 DO NOT SCALE PRINT

Figure 7-10. SCHEMATIC DIAGRAM, ELAPSED TIME INDICATOR (OPTION)



This illustration is intended to aid the reader in following the 306/500 wiring diagram (#63060123).

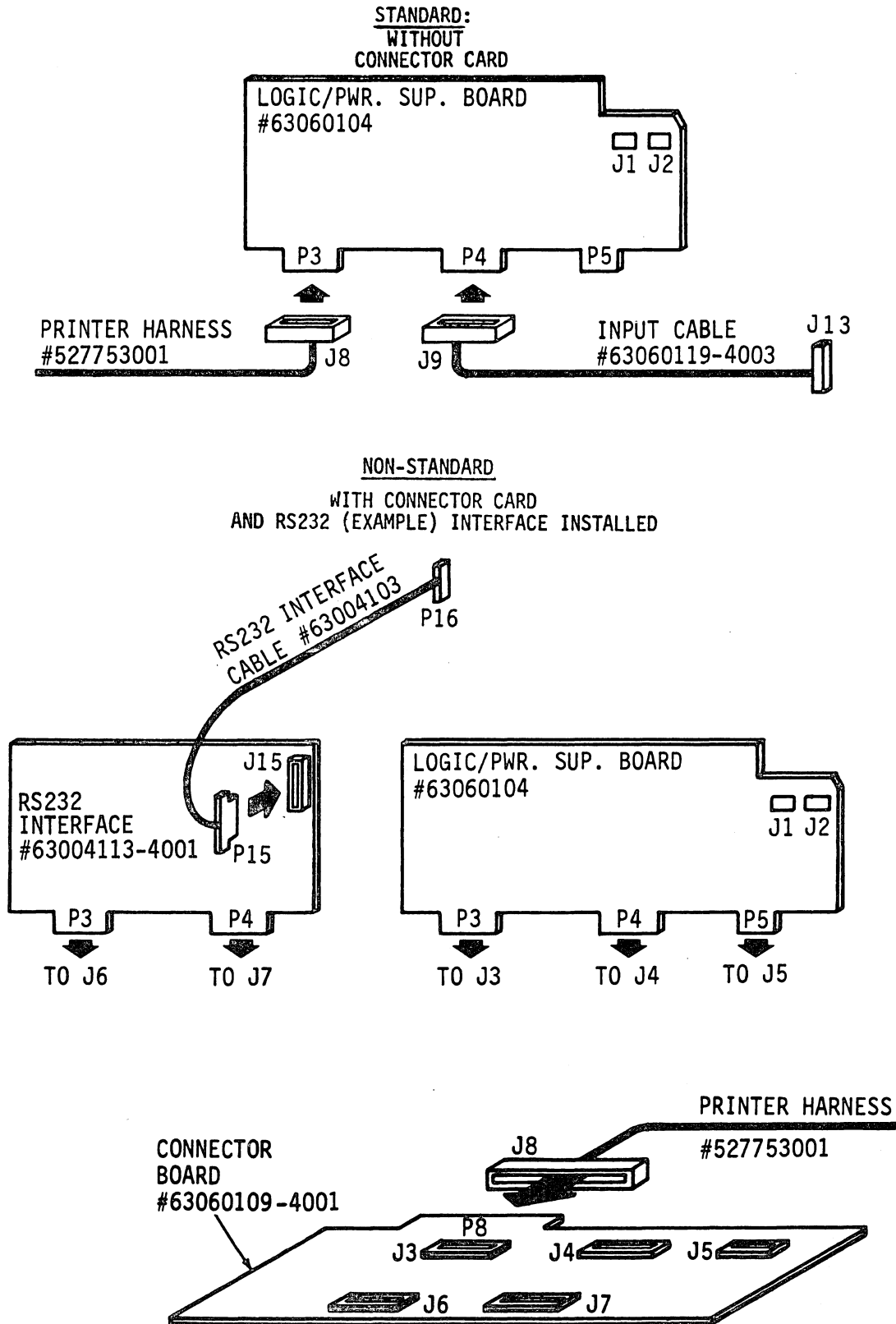
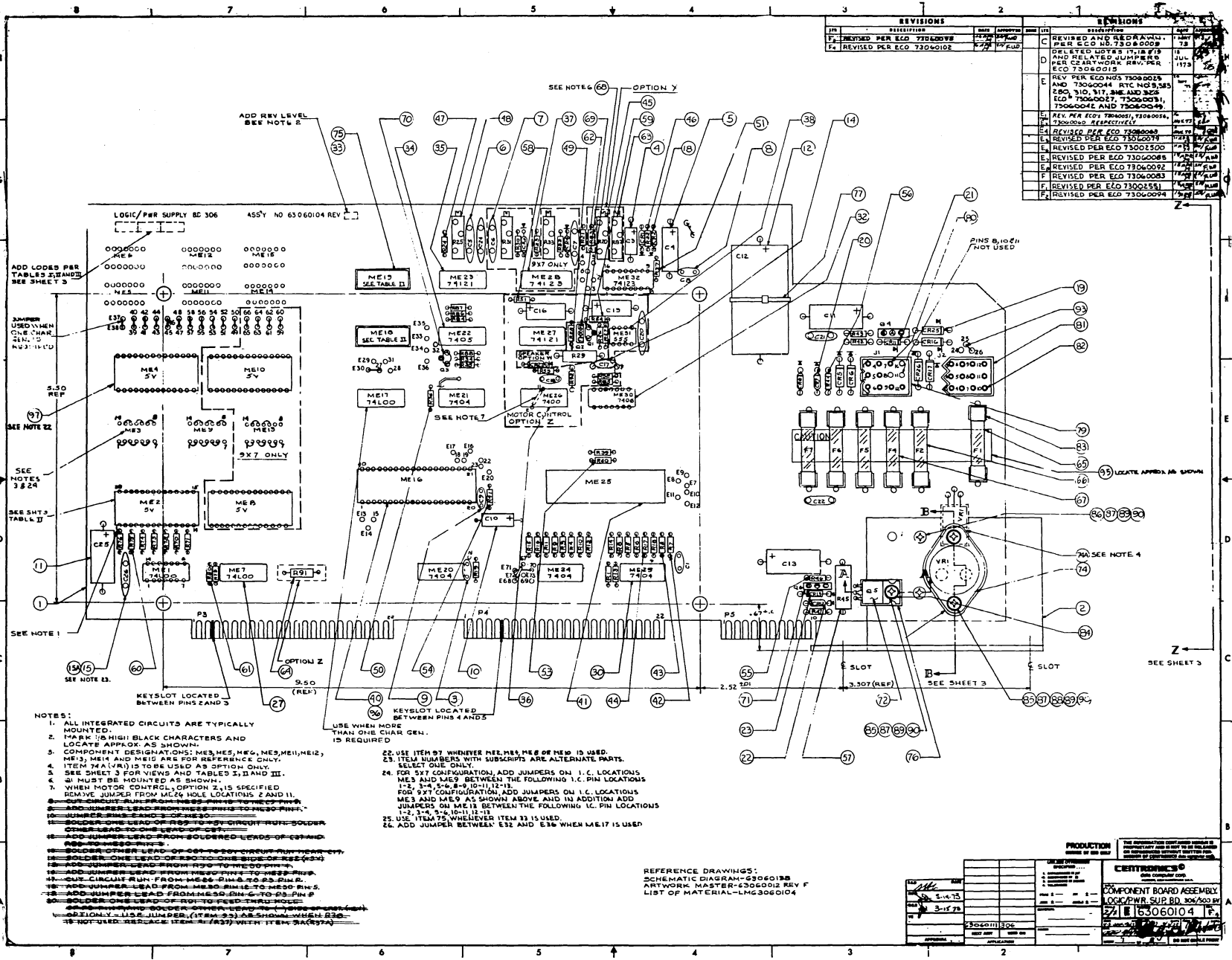

Figure 7-11. LOGIC/POWER SUPPLY BOARD CONNECTIONS

(This page intentionally left blank)

REV	REVISIONS	DATE	BY	CHK'D	REVISIONS	DATE	BY	CHK'D
1	REVISED PER ECO 73060008	7/27	WJL	WJL	A	REVISED PER ECO 73060008	7/27	WJL
2	REVISED PER ECO 73060002	7/27	WJL	WJL	B	REVISED PER ECO 73060002	7/27	WJL
3	REVISED PER ECO 73060002	7/27	WJL	WJL	C	REVISED AND REDRAWN PER ECO NO. 73060008	7/27	WJL
4	REVISED PER ECO 73060002	7/27	WJL	WJL	D	DELETED NOTES 17, 18, 27 AND RELATED JUMPERS PER CHARTWORK REV. PER ECO 73060013	7/27	WJL
5	REVISED PER ECO 73060025 AND 73060044. RTC NO'S 283, 310, 311, 314 AND 325	7/27	WJL	WJL	E	REV PER ECO NO'S 73060025 AND 73060044. RTC NO'S 283, 310, 311, 314 AND 325	7/27	WJL
6	REVISED PER ECO 73060031, 73060004, AND 73060049	7/27	WJL	WJL	F	REV PER ECO'S 73060031, 73060004, 73060004, AND 73060049	7/27	WJL
7	REV PER ECO'S 73060031, 73060004, 73060004, AND 73060049	7/27	WJL	WJL	G	REVISED PER ECO 73060008	7/27	WJL
8	REVISED PER ECO 73060008	7/27	WJL	WJL	H	REVISED PER ECO 73060094	7/27	WJL
9	REVISED PER ECO 73060008	7/27	WJL	WJL	I	REVISED PER ECO 73060008	7/27	WJL
10	REVISED PER ECO 73060008	7/27	WJL	WJL	J	REVISED PER ECO 73060008	7/27	WJL
11	REVISED PER ECO 73060008	7/27	WJL	WJL	K	REVISED PER ECO 73060008	7/27	WJL
12	REVISED PER ECO 73060008	7/27	WJL	WJL	L	REVISED PER ECO 73060008	7/27	WJL
13	REVISED PER ECO 73060008	7/27	WJL	WJL	M	REVISED PER ECO 73060008	7/27	WJL
14	REVISED PER ECO 73060008	7/27	WJL	WJL	N	REVISED PER ECO 73060008	7/27	WJL
15	REVISED PER ECO 73060008	7/27	WJL	WJL	O	REVISED PER ECO 73060008	7/27	WJL
16	REVISED PER ECO 73060008	7/27	WJL	WJL	P	REVISED PER ECO 73060008	7/27	WJL
17	REVISED PER ECO 73060008	7/27	WJL	WJL	Q	REVISED PER ECO 73060008	7/27	WJL
18	REVISED PER ECO 73060008	7/27	WJL	WJL	R	REVISED PER ECO 73060008	7/27	WJL
19	REVISED PER ECO 73060008	7/27	WJL	WJL	S	REVISED PER ECO 73060008	7/27	WJL
20	REVISED PER ECO 73060008	7/27	WJL	WJL	T	REVISED PER ECO 73060008	7/27	WJL
21	REVISED PER ECO 73060008	7/27	WJL	WJL	U	REVISED PER ECO 73060008	7/27	WJL
22	REVISED PER ECO 73060008	7/27	WJL	WJL	V	REVISED PER ECO 73060008	7/27	WJL
23	REVISED PER ECO 73060008	7/27	WJL	WJL	W	REVISED PER ECO 73060008	7/27	WJL
24	REVISED PER ECO 73060008	7/27	WJL	WJL	X	REVISED PER ECO 73060008	7/27	WJL
25	REVISED PER ECO 73060008	7/27	WJL	WJL	Y	REVISED PER ECO 73060008	7/27	WJL
26	REVISED PER ECO 73060008	7/27	WJL	WJL	Z	REVISED PER ECO 73060008	7/27	WJL



7-15

REV. E

Figure 7-12. PC BOARD ASS'Y, LOGIC/POWER SUPPLY BOARD (SHEET 1 OF 2)

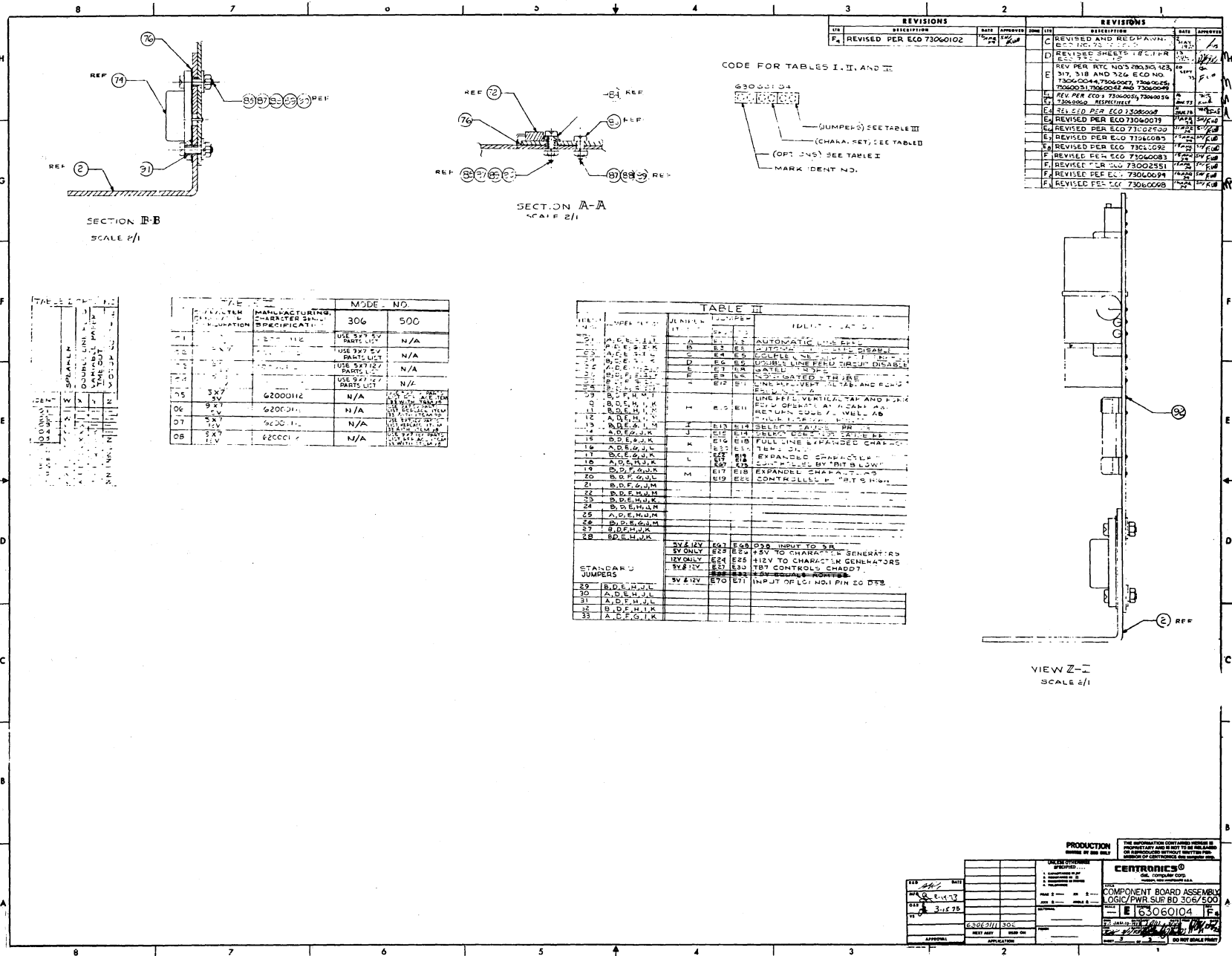
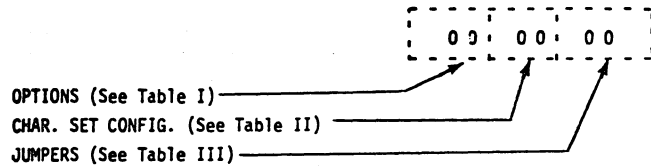

Figure 7-13. PC BOARD ASS'Y, LOGIC/POWER SUPPLY BOARD (SHEET 2 OF 2)

LIST OF MATERIALS  
 LOGIC/PWR. SUP. BD. 500  
 (Reference: Ass'y Dwg. #63060104, Rev. F4)

**NOTES:**

1. See Sheet 2 of drawing for board assembly configuration to determine LM items required.
2. The option code should be stamped on the component side of the board in the upper left-hand corner, to define the options, character set and jumpers contained on the board. The key to this 6-digit option code is as follows:



STANDARD BOARD 5 x 7 CHAR. GEN - NO OPTIONS

Item	Symbol	Part Number	Nomenclature	Quantity
1		63060013-1	Component Board	1
2		63060185	Heat Sink/Mounting Bkt.	1
3	C1, C2	21102000	Capacitor, .001 uf, 1KV	2
4	C3	22505002	Capacitor, 5 uf 16V	1
5	C4	22506002	Capacitor, 50 uf, 25V	1
6	C5, C24	21104001	Capacitor, .1 uf, 16V	2
7				
8	C8	21201000	Capacitor, 200 pf	1
9	C9	21101001	Capacitor, 100 pf, 1KV	1
10	C10	22106002	Capacitor, 10 uf, 25V	1
11	C13, C25, C11	22107002	Capacitor, 100 uf, 25V	3
12	C12	22507000	Capacitor, 500 uf	1
13				
14				

Item	Symbol	Part Number	Nomenclature	Quantity
15	C21, C22, C26	21103003	Capacitor, .01 uf	3
15A	C21, C22, C26	21103004	Capacitor, .01 uf, 50V, Seet Note 12	1
16				
17				
18	CR1, CR2	38100904	Diode, WG904	2
19	CR5, CR6, CR17	38130901	Diode, 30S1	6
-	CR16, CR25, CR26	38130901	Diode, 30S1	-
20	CR7, CR8	38040020	Diode, IN4002	2
21	CR11	38052350	Diode, IN5235	1
22	CR12	38047420	Diode, IN4742	1
23	CR13	38052460	Diode, IN5246	1
24				
25				
26				
27	ME1, ME7	35574000	Integrated Circuit 74L00	2
-	ME17	35574000	(See Dwg. ME17) 74L00	REF
28				
29	ME3, ME9	35474070	Integrated Circuit 7407	2
30	ME20, ME21	35474040	Integrated Circuit 7404	4
-	ME24, ME29	35474040	Integrated Circuit 7404	-
31				
32	ME30	35474060	Integrated Circuit 7406	1
33	ME18, ME19	35514810	QUAD 81 (See Table II)	2
34	ME22	35474050	Integrated Circuit 7405	1
35	ME23	35474121	Integrated Circuit 74121	1
36				
37	ME32	35474123	Integrated Circuit 74123	1
38				
39				
40	ME16	35512010	Integrated Circuit LSI No. 2	1
41	ME25	35512009	Integrated Circuit, LSI No. 1	1
42	R1, R3, R5,	41102926	Resistor, 1K, $\frac{1}{4}W$ , $\pm 10\%$	15
-	R7, R9, R11,	41102926	Resistor, 1K, $\frac{1}{4}W$ , $\pm 10\%$	-
-	R13, R15	41102926	Resistor, 1K, $\frac{1}{4}W$ , $\pm 10\%$	-
-	R34, R23,	41102926	Resistor, 1K, $\frac{1}{4}W$ , $\pm 10\%$	-
-	R35, R84	41102926	Resistor, 1K, $\frac{1}{4}W$ , $\pm 10\%$	-
-	R86, R87	41102926	Resistor, 1K, $\frac{1}{4}W$ , $\pm 10\%$	-
-	R88	41102926	Resistor, 1K, $\frac{1}{4}W$ , $\pm 10\%$	-

LIST OF MATERIALS  
 LOGIC/PWR. SUP. BD. 5C0  
 (Reference: Ass'y Dwg. #63060104, Rev. F4)

Item	Symbol	Part Number	Nomenclature	Quantity	Item	Symbol	Part Number	Nomenclature	Quantity
43	R2,R4,R6	41681926	Resistor, 680 ohms, 1/4W, +10%	9	71	Q6, Q4	38244420	Transistor, 2N4442	2
-	R8,R10,R12	41681926	Resistor, 680 ohms, 1/4W, +10%	-	72	Q5	38200300	Transistor, Tip 30	1
-	R14,R16	41681926	Resistor, 680 ohms, 1/4W, +10%	-	73				
-	R18	41681926	Resistor, 680 ohms, 1/4W, +10%	-	74	VR1	35203090	Voltage Regulator LM 309	1
44	R17,R19	41471926	Resistor, 470 ohms, 1/4W, +10%	2	74A	VR1	35207800	Voltage Reg uGH 780S See Note 12	REF
45	R20	46203381	Resistor, 20K Pot	1	75	XME18, 19	31410001-6	Socket, 16 Pin	2
46	R21,R43	41472926	Resistor, 4.7K, 1/4W, +10%	3	76		30050000	Silicone Compound	AR
-	R22	41472926	Resistor, 4.7K, 1/4W, +10%	-	77		39690010-2	Strap	1
47	R24	41222926	Resistor, 2.2K, 1/4W, +10%	1	79	J1	31300008-1	Connector, Molex, 1360P	1
48	R25	46103910	Resistor, 10K Pot	1	80		31240021-2	Pin, Molex, Male, 02-09-2133	10
49					81	J2	31340008-2	Connector, Molex, 1360 R-1	1
50	R36	41752926	Resistor, 7.5K, 1/4W, +10%	1	82		31240021-1	Pin, Molex, Female, 02-09-1133	12
51	R37	41184926	Resistor, 180K, 1/4W, +10%	1	83		31350003	Fuse Clip (102068 Cramer)	12
52					84		35000004-5	Washer Ins. Nylon	1
53	R39,R40	41221926	Resistor, 220 ohms, 1/4W, +10%	2	85		34517147	Screw, Pan HD/Phil, No. 4-40 x 7/16 lg	3
54	R41	41473926	Resistor, 47 ohms, 1/4W, +10%	1	86		34517107	Screw, Pan HD/Phil, No. 4-40 x 5/16 lg	2
55	R46,R42	41101926	Resistor, 100 ohms, 1/4W, +10%	2	87		34815007	Washer, Lock, Int. Tooth No. 4	5
56	R44,R47	41103926	Resistor, 10K, 1/4W, +10%	2	88		34912007	Washer, Flat, No. 4	2
57	R45	41331026	Resistor, 330 ohms, 2W	1	89		34712007	Nut, Hex, No. 4-40 UNC -2B	5
58					90		30000000	Insulating Varnish, Glyptl	AR
59					91		39690200-9	Sleeving, Ins. Teflon .25 lg	AR
60	R70, R71	41753926	Resistor, 75K, 1/4W, +10%	7	92		30070000	Solder (60/40)	AR
-	R72, R73	41753926	Resistor, 75K, 1/4W, +10%	-	93		39610000-5	Wire, Bus, No. 22 AWG	AR
-	R74, R75	41753926	Resistor, 75K, 1/4W, +10%	-	95		62000116-1	Caution Label	1
-	R76	41753926	Resistor, 75K, 1/4W, +10%	-	96		31410000	Socket, #821-23011-404	2
61	R79, R80	41473926	Resistor, 47K, 1/4W, +10%	2	97		31410001-04	Socket, 28 Pin #821-23011-284	1
62					98	ME18, ME19	35514811	Integrated Ckt. QUAD 133 See Table II	2
63					99				
64					100				
65	F1	39030011	Fuse, 3 AMP	1	101				
66	F2	39030018	Fuse, .5 AMP	1	102				
67	F4, F5	39030019	Fuse, 3 ASB	4	103				
-	F6, F7	39030019	Fuse, 3 ASB	-	104				
68					105				
69					-	ME2	See Ass Dwg	Sheet 3, Table III and 62000112	REF
70	Q3	38239060	Transistor, 2N3906	1	-	ME4	See Assy Dwg	Sheet 3, Table III and 62000112	REF

REV. E

7-18

LIST OF MATERIALS  
 LOGIC/PWR. SUP. BD. 500  
 (Reference: Ass'y Dwg. #63060104, Rev. F4)

9 x 7 CHAR. GEN.

Item	Symbol	Part Number	Nomenclature	Quantity
7	C6, C7	21224000	Capacitor, .22 uf	2
18	CR3, CR4	38100904	Diode, WG904	2
37	ME28	35474123	Integrated Circuit, 74123	1
46	R30, R32	41472926	Resistor, 4.7K, $\frac{1}{4}$ W, $\pm 10\%$	2
48	R31, R33	46103910	Resistor, 10K, Pot	2
100	Basic Bd.	63060104	5 x 7 Logic/Pwr. Sup. Bd. 500	1
-	ME2	See Assy Dwg	Sheet 3, Table III, and 62000112	REF
-	ME4	See Assy Dwg	Sheet 3, Table III, and 62000112	REF
-	ME8	See Assy Dwg	Sheet 3, Table III, and 62000112	REF
-	ME10	See Assy Dwg	Sheet 3, Table III, and 62000112	REF

SPEAKER OPTION W

Item	Symbol	Part Number	Nomenclature	Quantity
20	CR27	38040020	Diode, IN4002	1
42	R26	41102926	Resistor, 1K, $\frac{1}{4}$ W, $\pm 10\%$	1
44	R28	41471926	Resistor, 470 ohm, $\frac{1}{4}$ W, $\pm 10\%$	1
47	R27	41222926	Resistor, 2.2K, $\frac{1}{4}$ W, $\pm 10\%$	1
49	R29	41220016	Resistor, 22 ohm, 1W, $\pm 10\%$	1
68	Q1	38239040	Transistor, 2N3904	1
69	Q2	38300050	Transistor, MPS u05	1

DOUBLE LINE FEED OPTION X

Item	Symbol	Part Number	Nomenclature	Quantity
62	R83	41203925	Resistor, 20K, $\frac{1}{4}$ W, $\pm 5\%$	1
63	R82	46203381	Resistor, 20K Pot	1

MOTOR CONTROL OPTION Z

3	C18	21102000	Capacitor, .001 uf	1
10	C19	22106002	Capacitor, 10 uf	1
14	C17	21123000	Capacitor, .022 uf, 16V	1
15	C20	21103003	Capacitor, .01 uf	1
15A	C20	21103004	Capacitor, .01 uf See Note 12	1
35	ME27	35474121	Integrated Circuit 74121	1
36	ME26	35474000	Integrated Circuit 7400	1
38	ME31	35205550	Integrated Circuit 555	1
42	R52, R85	41102926	Resistor, 1K, $\frac{1}{4}$ W, $\pm 10\%$	2
46	R53	41472926	Resistor, 4.7K, $\frac{1}{4}$ W, $\pm 10\%$	1
58	R51	41203926	Resistor, 20K, $\frac{1}{4}$ W, $\pm 10\%$	1
59	R54	41684926	Resistor, 680K, $\frac{1}{4}$ W, $\pm 10\%$	1
64	R91	41102946	Resistor, 1K, $\frac{1}{4}$ W, $\pm 10\%$	1
65	C16	22206002	Capacitor, 20 uf, 25V	1
66	R92	41103926	Resistor, 10K, $\frac{1}{4}$ W, $\pm 10\%$	1

**Figure 7–14**

**INTENTIONALLY OMITTED**



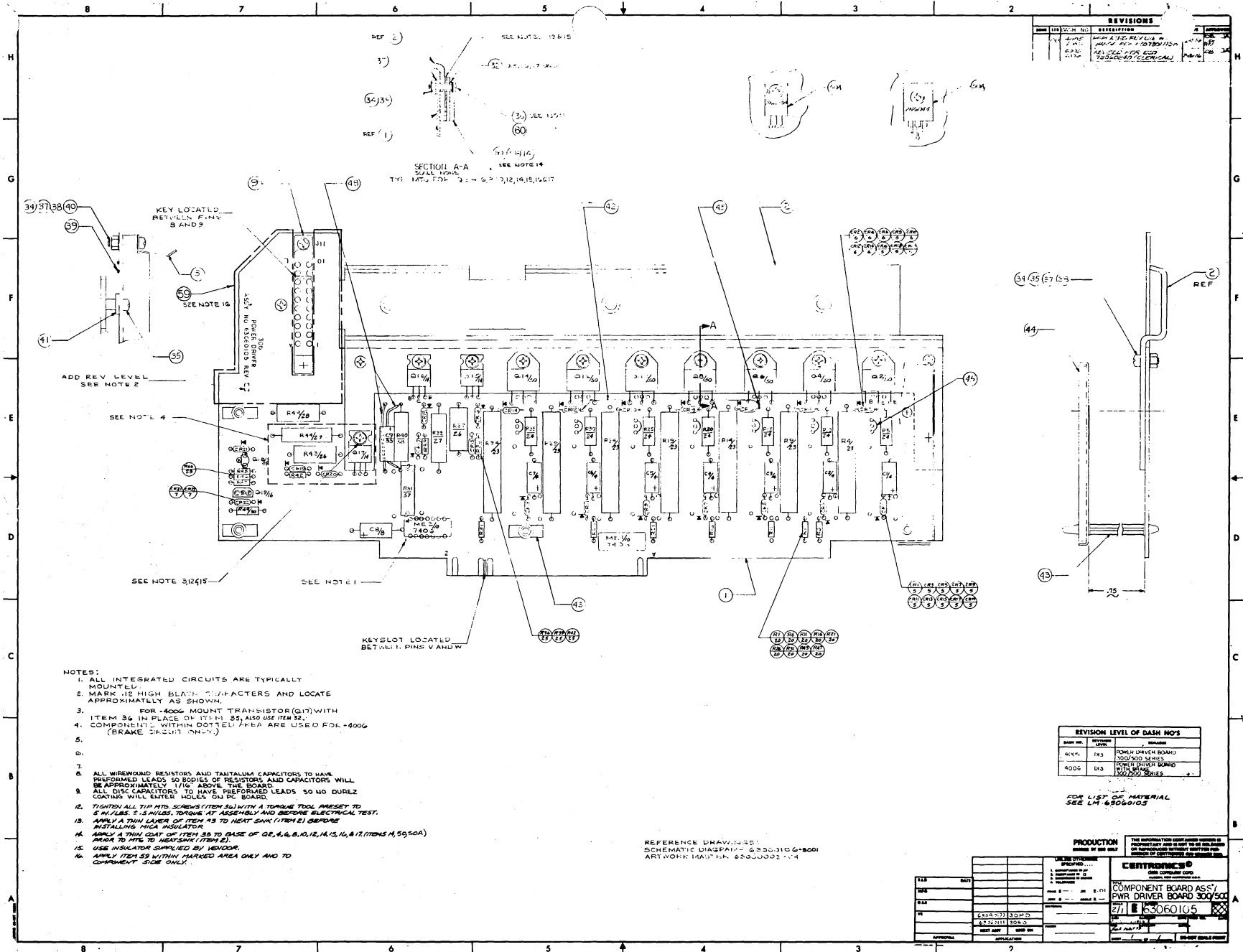

REVISIONS			
REV	DATE	DESCRIPTION	BY
1	11/15/71	INITIAL REV. FOR 100001200	RP
2	11/15/71	REV. FOR 100001200	RP
3	11/15/71	REV. FOR 100001200	RP

- NOTES:
1. ALL INTEGRATED CIRCUITS ARE TYPICALLY MOUNTED.
  2. MARK 1/2 HIGH BLANK CAPACITORS AND LOCATE APPROXIMATELY AS SHOWN.
  3. FOR 4006 MOUNT TRANSISTOR (Q17) WITH ITEM 36 IN PLACE OF ITEM 35; ALSO USE ITEM 32.
  4. COMPONENTS WITHIN DOTTED AREA ARE USED FOR 4006 (BRAKE DISCUSSION).
  - 5.
  - 6.
  7. ALL MIDSERIES RESISTORS AND TANTALUM CAPACITORS TO HAVE PERFORMED LEADS SO BODIES OF RESISTORS AND CAPACITORS WILL BE APPROXIMATELY 1/16" ABOVE THE BOARD.
  8. ALL DISK CAPACITORS TO HAVE PERFORMED LEADS SO NO DUREZ COATING WILL ENTER HOLES ON PC BOARD.
  9. TIGHTEN ALL TYP. HTS. SCREWS (ITEM 30) WITH A TORQUE TOOL ADJUSTED TO 5 IN. LBS. 2-5 IN. LBS. TORQUE AT ASSEMBLY AND BEFORE ELECTRICAL TEST.
  10. APPLY A THIN LAYER OF ITEM 95 TO HEAT SINK (ITEM 2) BEFORE INSTALLING HIGH INSULATOR.
  11. APPLY A THIN COAT OF ITEM 38 TO BASE OF Q2, R4, R6, R10, R12, R14, R15, R16, R17 (ITEMS 4, 50, 50A) PRIOR TO HTS TO HEAT SINK (ITEM 2).
  12. USE INSULATOR SUPPLIED BY VENDOR.
  13. APPLY ITEM 59 WITHIN MARKED AREA ONLY AND TO COMPONENT SIDE ONLY.

REVISION LEVEL OF DASH NOS			
DASH NO.	LEVEL	REVISION	REASON
41571	FK3	POWER DRIVER BOARD	1000000 SERIES
4000	DN3	POWER DRIVER BOARD	1000000 SERIES

FOR LIST OF MATERIAL SEE LHM 63060105

REFERENCE DRAWING NO. SCHEMATIC DIAGRAM 63060105-8001  
ARTWORK: HAN, HAN, 63060003-114

PRODUCTION		CENTRONIC	
DATE	QUANTITY	DATE	QUANTITY
THE INFORMATION CONTAINED HEREIN IS PROPRIETARY AND IS NOT TO BE DISCLOSED OR REPRODUCED WITHOUT WRITTEN PERMISSION OF CENTRONIC CORPORATION.		<b>CENTRONIC</b> 271 E. 83060105 COMPONENT BOARD ASS'Y PWR. DRIVER BOARD 300/500	

Figure 7-15. PC BOARD ASS'Y, POWER DRIVER BOARD

LIST OF MATERIALS  
PC BOARD ASSEMBLY  
POWER DRIVER W/O BRAKE  
(Reference: Ass'y No. 63060105-4005, Rev. D13)

ITEM	PART NO.	NOMENCLATURE	QTY PER
1	63060003-2001	PC BD AW 306 DRIVER	1
2	63060113-2001	HEAT SINK/MTG BKT PWR DR. 306	1
3	63002300-2001	CLIP, P.C. BOARD	2
4	22405003-1001	CAP ELECTROLYTIC 4UF 50V	7
5	38100904-1001	DIODE WG904	9
6	38040020-1001	DIODE S1 RECTIFIER IN4002	9
7	38047321-1001	DIODE ZENER IN4732A	2
8	22106002-1001	CAP ELECTROLYTIC 10UF 25V	1
9	31230011-1001	CONNECTOR EDGE 20 PIN	1
10	35474060-1001	INTEGRATED CIRCUIT 7406	2
14	38201110-1001	TRANSISTOR TIP111	2
15	38239060-1001	TRANSISTOR PNP GEN PUR 2N3906	1
16	38300050-1001	TRANSISTOR NPN HI VOLT MPS V05	1
20	41102926-1001	RES CARBON 1 K 1/4W 10%	9
23	43158105-1001	RES WW 1.5 OHM 10W 5%	7
24	40680325-1001	RES 68 OHM 3-1/4W 5%	7
25	41222926-1001	RES CARBON 2.2 K 1/4W 10%	2
26	41101026-1001	RES CARBON 100 OHM 2W 10%	1
28	41102026-1001	RES CARBON 1 K 2W 10%	1
29	41221926-1001	RES CARBON 220 OHM 1/4W 10%	1
30	41471946-1001	RES CARBON 470 OHM 1/2W 10%	1
32	35000004-2005	WASHER-NYLON INSULATOR #4X3/16	2
33	30050000-0001	SILICONE COMPOUND	A/R
34	30000000-0001	INSULATING VARNISH	A/R
35	34517105-2001	SCREW 4/40X5/16 PAN HD PHIL SS	5
36	34517145-2001	SCREW 4/40X7/16 PAN HD PHIL SS	9
37	34815005-2001	WASHER #4 INT TOOTH LOCK SS	15
38	34712005-2001	NUT HEX 4/40 SS	15
39	30070000-0001	SOLDER	A/R
40	34517165-2001	SCREW 4/40X1/2 PAN HD PHIL SS	2
41	34000019-2001	WASHER #6 FLAT FIBRE	2
43	36600004-2006	STANDOFF LCBS-12 PLASTIC	5
44	63060114-2001	SHIELD POWER DRIVER	1
45	39610000-0005	WIRE BUSS #22AWG	A/R
48	39690200-0020	TUBING TEFLON TFT 200 #20 NAT	A/R
50	63060346-6001	KIT TRANS TIP 141 & INSULATOR	1
50A	63060347-6001	KIT TRANS 2N6388 & INSULATOR	A/R
55	22206002-1001	CAP ELECTROLYTIC 20UF 25V	1
56	43120055-1001	RES WW 12 OHM 5W 5%	1
57	43568056-1001	RES WW 5.6 OHM 5W 10%	1
58	41221016-1001	RES CARBON 220 OHM 1W 10%	1
59	30040002-0001	CONFORMAL COATING	A/R
60	34000050-2001	WASHER #4 FLAT 1/40DX1/32THK	9
REF	63060004-9001	PC BD DD 306 DRIVER	A/R
REF	63060106-9001	SCHEM DIAG PWR DRVR 300/500 SR	A/R

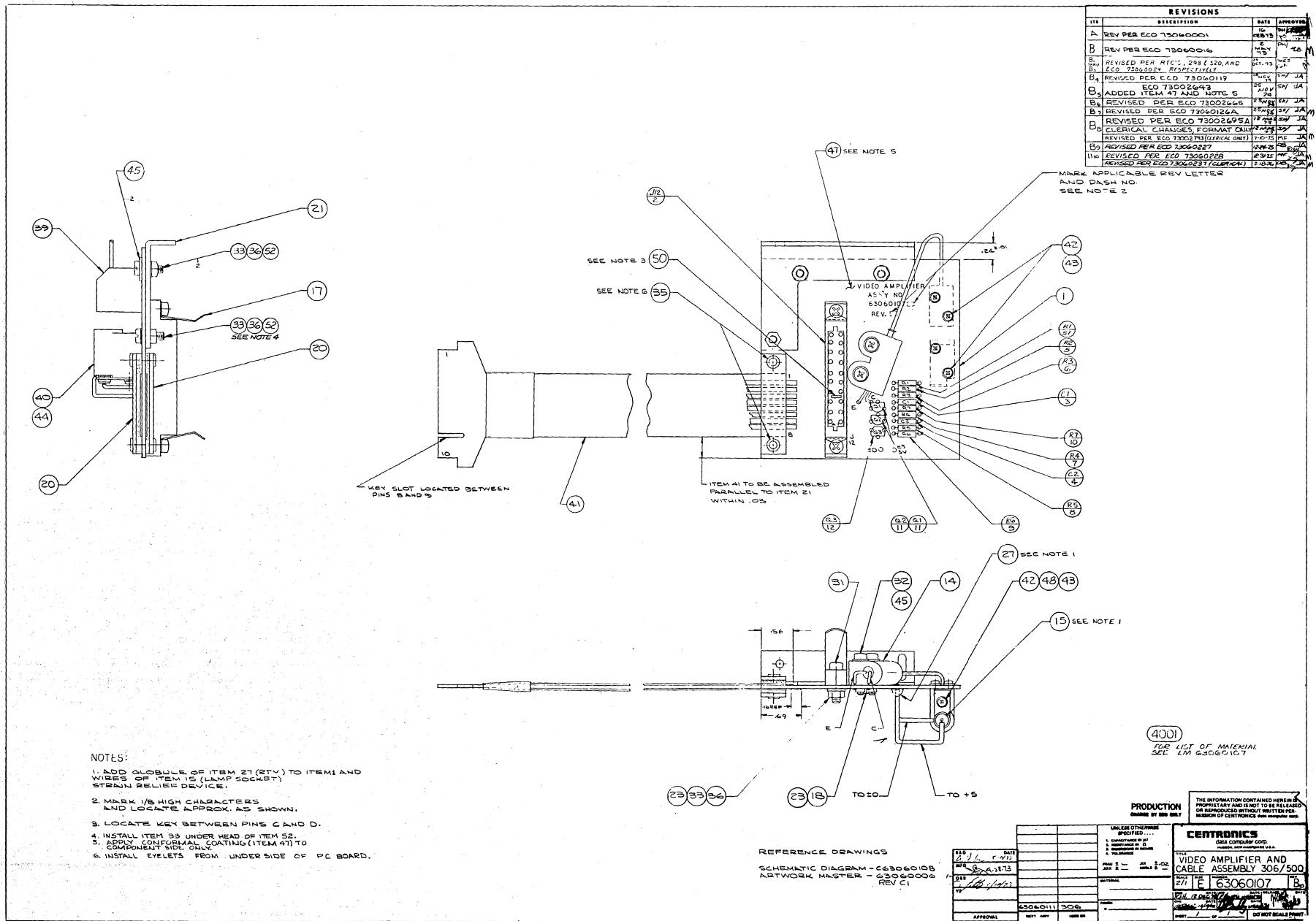

REV	DESCRIPTION	DATE	APPROVAL
A	REV PER ECO 73060001	12-13	JA
B	REV PER ECO 73060016	1-75	JA
B1	REVISED PER RTC'S 248 & 220 AND ECO 73060024 RESPECTIVELY	2-75	JA
B4	REVISED PER ECO 73060119	2-75	JA
B5	ADDED ITEM 47 AND NOTE 5	2-75	JA
B6	REVISED PER ECO 73060265	2-75	JA
B7	REVISED PER ECO 73060266	2-75	JA
B8	REVISED PER ECO 73060267	2-75	JA
B9	REVISED PER ECO 73060268	2-75	JA
B10	REVISED PER ECO 73060269	2-75	JA
B11	REVISED PER ECO 73060270	2-75	JA
B12	REVISED PER ECO 73060271 (GENERAL)	2-75	JA

- NOTES:
1. ADD GLOBULE OF ITEM 27 (RTV) TO ITEM 1 AND WIRES OF ITEM 15 (LAMP SOCKET) STRAIN RELIEF DEVICE.
  2. MARK 1/8 HIGH CHARACTERS AND LOCATE APPROX. AS SHOWN.
  3. LOCATE KEY BETWEEN PINS C AND D.
  4. INSTALL ITEM 33 UNDER HEAD OF ITEM 52.
  5. APPLY CONFORMAL COATING (ITEM 47) TO COMPONENT SIDE ONLY.
  6. INSTALL EYELETS FROM UNDER SIDE OF PC BOARD.

REFERENCE DRAWINGS  
 SCHEMATIC DIAGRAM - 63060108  
 NETWORK MASTER - 63060008 REV C1

DESIGNED BY	DATE	UNLESS OTHERWISE SPECIFIED
CHKD BY	DATE	1. CONFORMS TO 2. APPROVED BY 3. AUTHORITY
APP'D BY	DATE	FORM 2 - JAN 1-62
63060111 306		PRODUCTION
		THE INFORMATION CONTAINED HEREIN IS PROPRIETARY AND IS NOT TO BE RELEASED OR REPRODUCED WITHOUT WRITTEN PERMISSION OF CENTRONICS, INC.
		<b>CENTRONICS</b> 63060107 VIDEO AMPLIFIER AND CABLE ASSEMBLY 306/500
		DO NOT SCALE DIM.

Figure 7-16. PC BOARD ASS'Y, VIDEO AMPLIFIER AND CABLE ASS'Y

LIST OF MATERIALS  
PC BOARD ASSEMBLY  
VIDEO AMP. AND CABLE ASSY  
(Reference: Ass'y No. 63060107-4001, Rev. B10)

ITEM	PART NO.	NOMENCLATURE	QTY PER
1	63060006-2001	PC BD AW VIDEO AMPLIFIER	1
2	31230011-1001	CONNECTOR EDGE 20 PIN	1
3	21821004-1001	CAP CERAMIC DISC 820PF 100V	1
4	21472004-1001	CAP CERAMIC DISC .0047UF 1KV	1
5	41224926-1001	RES CARBON 220 K 1/4W 10%	1
6	41473926-1001	RES CARBON 47 K 1/4W 10%	1
7	41472926-1001	RES CARBON 4.7 K 1/4W 10%	1
8	41103926-1001	RES CARBON 10 K 1/4W 10%	1
9	41102926-1001	RES CARBON 1 K 1/4W 10%	1
10	41474926-1001	RES CARBON 470 K 1/4W 10%	1
11	38234060-1001	TRANSISTOR PNP GEN PUR 2N3906	2
12	38239040-1001	TRANSISTOR NPN GEN PUR 2N3904	1
14	63002257-5001	PHOTOCELL AND HOUSING ASSEMBLY	1
15	63002598-4001	LAMP SOCKET ASSY	1
17	63002300-2001	CLIP, P.C. BOARD	2
18	34059161-2001	PEMSERT 4/40	2
20	63060116-5001	CLAMP ASSY	2
21	63060115-2001	MTG BRKT VIDEO AMP BOARD	1
23	30000000-0001	INSULATING VARNISH	A/R
27	30060000-0001	SILICONE RUBBER RTV	A/R
28	30070000-0001	SOLDER	A/R
31	34517167-2001	SCREW 4/40X1/2 PAN HD PHIL	2
32	34517247-2001	SCREW 4-40X3/4 PAN HD PHIL	2
33	34815007-2001	WASHER #4 INT TOOTH LOCK	5
35	33490001-2022	EYELET	2
36	34712007-2001	NUT HEX 4/40	5
39	63002248-2001	FIBRE OPTICS HEAD	1
40	63002259-2001	LAMP HOUSING	1
41	63060146-4001	RIBBON CABLE ASSEMBLY	1
42	34507087-2001	SCREW 2/56X1/4 PAN HD PHIL	5
43	34902007-2001	WASHER #2 FLAT	5
44	37253790-1001	LAMP	1
45	34912007-2001	WASHER #4 FLAT	4
47	30040000-0001	CONFORMAL COATING OP2	A/R
48	34805007-2001	WASHER #2 INT TOOTH LOCK	1
50	31240456-2002	KEY POLARIZING BETWEEN CONTACT	1
51	41104926-1001	RES CARBON 100K 1/4W 10%	1
52	34517127-2001	SCREW 4/40X3/8 PAN HD PHIL	3
REF	63060007-9001	PC BD DD VIDEO AMPLIFIER	
REF	63060108-9001	SCHEM DIA VIDEO AMP 306/500	

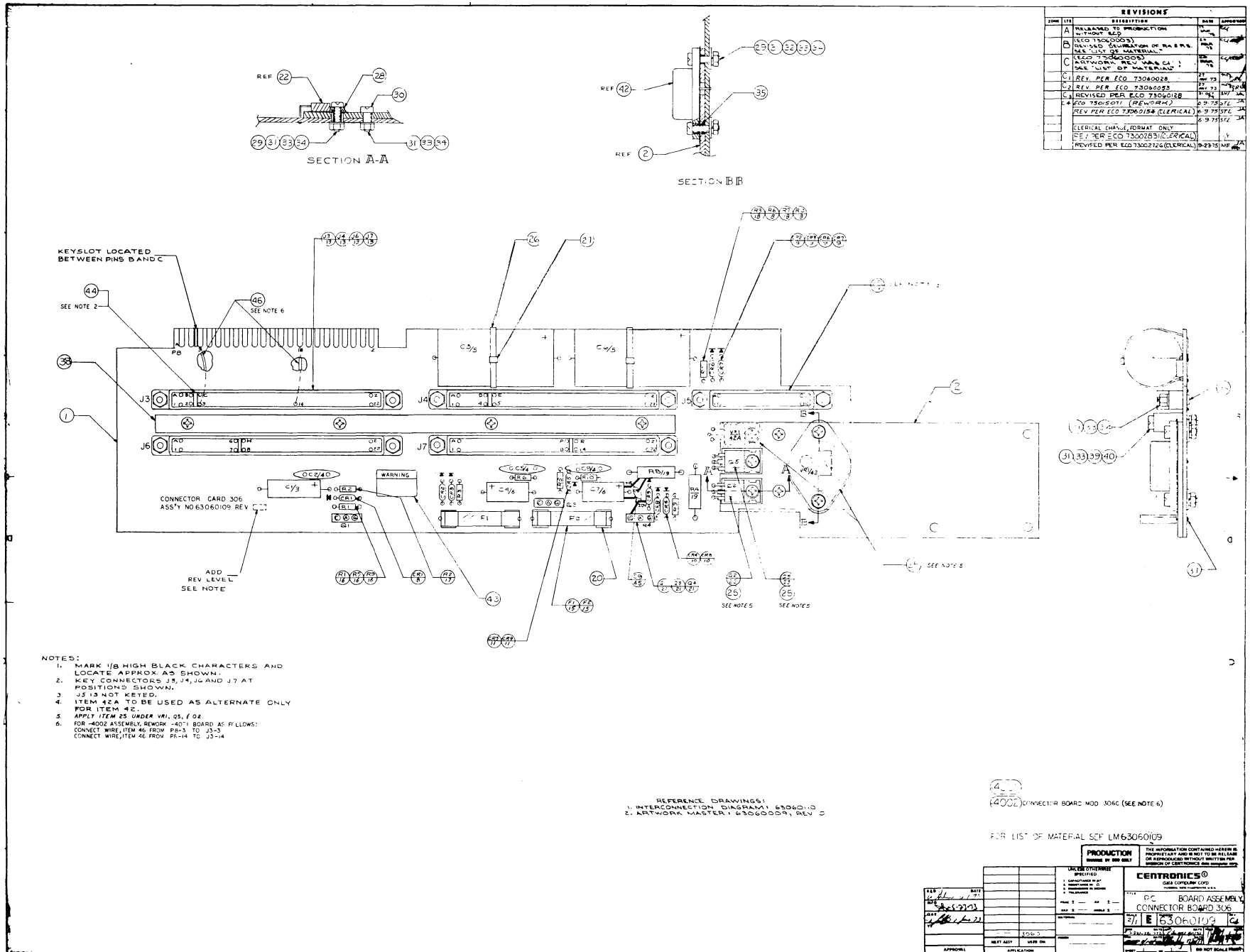

REVISIONS			
FORM	DATE	REVISION	APPROVED
A		RELEASED TO PRODUCTION WITHOUT ECG	
B		ECG 7300003	
C		REVISED QUANTITIES OF PARTS PER NETWORK REV. WALK-CAL	
		SEE LIST OF MATERIAL	
		REV. PER ECG 7300028	
		REV. PER ECG 7300025	
		REVISED PER ECG 7300038	
		ECG 7300501 (REWORK)	
		REV PER ECG 7300514 (CERICAL)	
		CERICAL (HALL/ISBAT ONLY)	
		REV PER ECG 7300283 (CERICAL)	
		REVISED PER ECG 7300212 (CERICAL)	

- NOTES:
- MARK 1/8 HIGH BLACK CHARACTERS AND LOCATE APPROX AS SHOWN.
  - KEY CONNECTORS J3, J4, J6 AND J7 AT POSITIONS SHOWN.
  - J3 IS NOT KEYS.
  - ITEM 42A TO BE USED AS ALTERNATE ONLY FOR ITEM 42.
  - APPLY ITEM 25 UNDER VRI, Q5, F OR.
  - FOR -4002 ASSEMBLY REWORK -4071 BOARD AS FOLLOWS:  
CONNECT WIRE, ITEM 46 FROM P1-3 TO J3-3  
CONNECT WIRE, ITEM 46 FROM P1-14 TO J3-14

REFERENCE DRAWINGS:  
1. INTERCONNECTION DIAGRAM 6306010  
2. ARTWORK MASTER 6306009, REV 2

4002 CONNECTOR BOARD MOD 306 (SEE NOTE 6)

FOR LIST OF MATERIAL SEE LM 63060109

THE INFORMATION CONTAINED HEREIN IS PROPRIETARY AND IS NOT TO BE RELEASED OR REPRODUCED WITHOUT WRITTEN PERMISSION OF CENTRONICS CORPORATION.	
PRODUCTION NUMBER BY 888 8887	CENTRONICS® DATA COMPUTER CORP.
PC BOARD ASSEMBLY CONNECTOR BOARD 306	63060109
DATE: 11/17/73 BY: J. J. J. J. CHECKED: J. J. J. J.	APPROVAL: [Signature] APPLICATION: [Signature]

Figure 7-17. PC BOARD ASS'Y, CONNECTOR CARD

LIST OF MATERIALS  
PC BOARD ASSEMBLY  
CONNECTOR CARD  
(Reference: Ass'y #63060109-4001, Rev. )

7-27

Rev. E

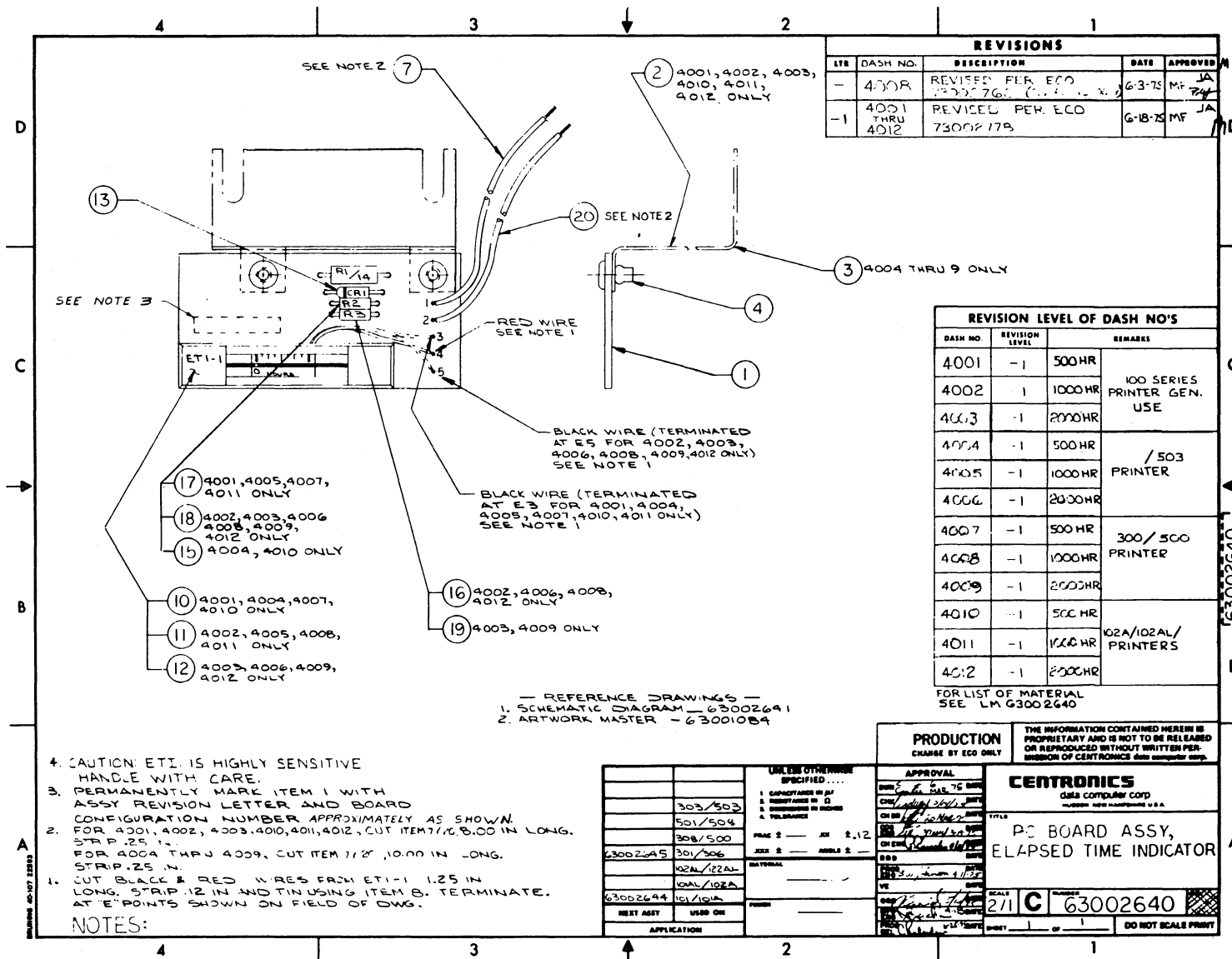

Figure 7-18. PC BOARD ASS'Y, ELAPSED TIME INDICATOR (OPTION)

LIST OF MATERIALS  
PC BOARD ASSEMBLY  
ELAPSED TIME INDICATOR  
63002640 (500 HR) REV -1

ITEM	PART NO.	NOMENCLATURE	QTY PER
1	63001084-2001	PC BD AW ETI GEN USE	1
3	63002642-2001	BRKT ETI BD 300/500 SERIES	1
4	33453421-2001	RIVET PCP 1/8 DIA X 1/8 LG	2
7	39648505-C004-2	WIRE TYPE B 26AWG RED	A/R
8	3007C0C0-C001	SOLDER	A/R
10	35811200-1001	ELAPSED TIME INDICATOR 500 HRS	1
13	38052311-1001	DIODE IN5231A	1
14	41222946-1001	RES 2.2K 1/2W 10%	1
17	41754925-1001	RES CARBON 750 K 1/4W 5%	1
20	39648505-C004-0	WIRE TYPE B 26AWG BLACK	A/R
REF	63001085-9C01	PC BD DD ETI GEN USE	A/R
REF	63002641-9C01	SCHEM DIAG ETI GEN USE	A/R

63002640-4008 (1000 HR) REV -1

ITEM	PART NO.	NOMENCLATURE	QTY PER
1	63001084-2001	PC BD AW ETI GEN USE	1
3	63002642-2001	BRKT ETI BD 300/500 SERIES	1
4	33453421-2001	RIVET PCP 1/8 DIA X 1/8 LG	2
7	39648505-0004-2	WIRE TYPE B 26AWG RED	A/R
8	3007C000-0001	SOLDER	A/R
11	35811200-1002	ELAPSED TIME INDICATOR 1000HRS	1
13	38052311-1001	DIODE IN5231A	1
14	41222946-1001	RES 2.2K 1/2W 10%	1
16	41564926-1001	RES 560K 1/4W 10%	1
18	41105926-1001	RES CARBON 1 MEG 1/4 W 10%	1
20	39648505-C004-0	WIRE TYPE B 26AWG BLACK	A/R
REF	63001085-9C01	PC BD DD ETI GEN USE	A/R
REF	63002641-9C01	SCHEM DIAG ETI GEN USE	A/R

63002640-4009 (2000 HR) REV -1

ITEM	PART NO.	NOMENCLATURE	QTY PER
1	63001084-2001	PC BD AW ETI GEN USE	1
3	63002642-2001	BRKT ETI BD 300/500 SERIES	1
4	33453421-2001	RIVET PCP 1/8 DIA X 1/8 LG	2
7	39648505-C004-2	WIRE TYPE B 26AWG RED	A/R
8	30070000-C001	SOLDER	A/R
12	35811200-1003	ELAPSED TIME INDICATOR 2000HRS	1
13	38052311-1001	DIODE IN5231A	1
14	41222946-1001	RES 2.2K 1/2W 10%	1
18	41105926-1001	RES CARBON 1 MEG 1/4 W 10%	1
19	41205925-1001	RES 2MEG 1/4W 5%	1
20	39648505-C004-0	WIRE TYPE B 26AWG BLACK	A/R
REF	63001085-9C01	PC BD DD ETI GEN USE	A/R
REF	63002641-9001	SCHEM DIAG ETI GEN USE	A/R



THE INFORMATION CONTAINED HEREIN IS PROPRIETARY AND IS NOT TO BE RELEASED OR REPRODUCED WITHOUT WRITTEN PERMISSION OF CENTRONICS data computer corp.

REVISIONS				
LT#	DASH NO.	DESCRIPTION	DATE	APPROVED
E	4001	REPAIRED PER ECN 73260170	6-17-75	MF JA
E	4002	REVISED PER ECO 73500017	1-14-76	DB JA
E	4004	ADDED PER ECO 73500017		DB JA
E	4003	REVISED PER ECO 73660239	2-27-76	DB JA
A	4002			MF JA

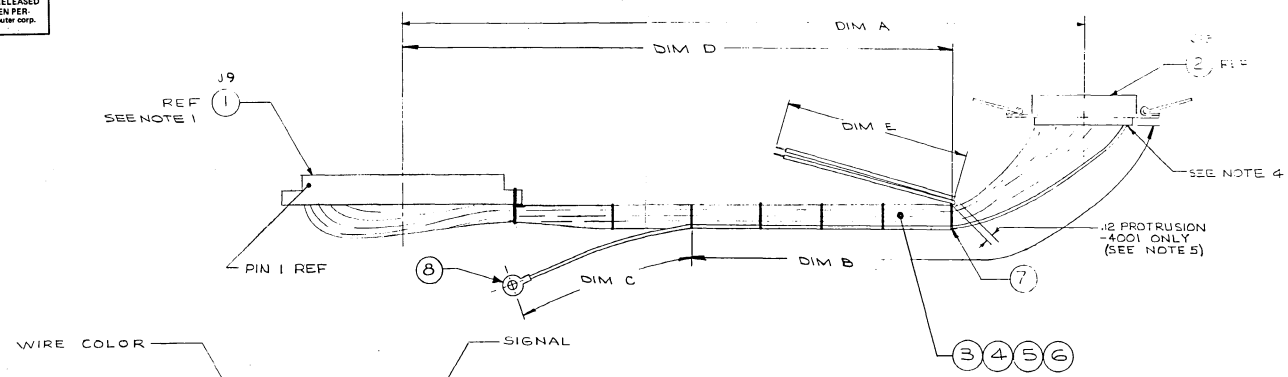

WIRE COLOR	SIGNAL	J9	J13
YEL	LD	A	33
BLK	IOV	B	16
RED	LINE PULSE CNT (-2 AND -4 ONLY)	C	34
BLK	LOW FREQ OSC (-2 AND -4 ONLY)	D	11
RED	BUSY	E	29
WHT	BUSY RETURN	F	14
WHT	SPEAKER (-2 ONLY)	G	35
WHT	LINE PULSE CNT RET (-2 ONLY)	H	13
BLK	SPEAKER RET (-2 ONLY)	I	15
YEL	SLCT	J	14
YEL	OSCXT	K	12
BLK	SSIOV	L	31
YEL	PE	M	30
RED	INPUT PRIME	N	32
WHT	INPUT PRIME RET	O	7
YEL	FAULT	P	25
RED	DATA 6	Q	7
WHT	DATA 6 RET	R	25

J9	RED	DATA 2	J13	9
N	WHT	DATA 8 RETURN	19	27
12	P	YEL	+5V	18
13	⊙	BLK	CHASSIS GRD	17
R				
14	RED	DATA 5	6	
S	WHT	DATA 5 RETURN	24	3
15	P	RED	DATA 2	24
T	WHT	DATA 2 RETURN	21	4
16	P	RED	DATA 3	4
U	WHT	DATA 3 RETURN	22	2
V	RED	DATA 1	2	20
17	P	WHT	DATA 1 RETURN	20
W	P	RED	DATA 7	8
19	WHT	DATA 7 RETURN	26	5
X	P	RED	DATA 4	5
20	WHT	DATA 4 RETURN	23	1
Y	P	RED	DATA STROBE	19
21	WHT	DATA STROBE RET.	19	10
Z	P	RED	ACKNL 3	10
22	WHT	ACKNL 6 RETURN	25	

DASH NO.	DIM A	DIM B	DIM C	DIM D	DIM E	USAGE
-4001	9.00	3.00	4.00	—	—	306
-4002	9.00	3.00	4.00	7.00	4.00	101AL
-4003	13.50	3.00	5.00	—	—	500
-4004	24.00	3.00	6.00	—	—	500D

DASH NO.	REVISION LEVEL	REMARKS
4001	E	MODEL 306
4002	F	MODEL 101AL
4003	E	MODEL 500
4004	A	MODEL 500D

- CUT BOTH WIRES SO THAT APPROXIMATELY .12 (REF) LENGTH IS PROTRUDING BEYOND THE TIE.
- INSTALL ITEM 10 ON EVERY OTHER PIN AND STAGGER BETWEEN ROWS ON ITEM 2.
- STRIP ALL LEADS .25 INCH ON BOTH ENDS AND TIN BEFORE ASSEMBLY.
- LEADS SHOWN WITH SYMBOL SIGNIFY TWISTED PAIR.
- LOCATE KEY BETWEEN PINS 4 & 5

FOR LIST OF MATERIAL SEE LM 63060119

PRODUCTION CHANGE BY ECO ONLY

UNLESS OTHERWISE SPECIFIED... 1. CAPACITANCE IN μF 2. RESISTANCE IN Ω 3. DIMENSIONS IN INCHES 4. TOLERANCE		<b>CENTRONICS</b> DATA COMPUTER CORP. PLYMOUTH, NEW HAMPSHIRE U.S.A.
R&D DATE MFG DATE 3-14-73 GAR DATE 3-15-75 VE	PART # 5000 3015 63060111 306 1500	
TITLE <b>CABLE ASSEMBLY DATA INPUT</b>		SCALE SIZE NUMBER <b>D 63060119</b>
APPROVAL NEXT ASBY USED IN		DATE PREPARED DATE CHECKED DATE TESTED DATE INSP. DATE SHIPPED

Figure 7-19. CABLE ASS'Y, DATA INPUT

LIST OF MATERIALS  
 DATA INPUT CABLE 306  
 (Reference: Ass'y No. 63060119-4001, Rev. E)

ITEM	PART NO.	NOMENCLATURE	QTY PER
1	31230038-1001	CONNECTOR EDGE 44 PIN	1
2	31310019-1016	CONN 36 CONTACT NOT KEYED	1
3	39648505-0004-2	WIRE TYPE B 26AWG RED	9.8
4	39648505-0004-9	WIRE TYPE B 26AWG WHITE	10.3
5	39648505-0004-4	WIRE TYPE B 26AWG YELLOW	4.5
6	39648505-0004-0	WIRE TYPE B 26AWG BLACK	2.8
7	39690000-0001	TAPE LACING WHITE .010X1/16W	A/R
8	31460000-2003	TERMINAL RING NO 8 22-24 AWG	1
9	30070000-0001	SOLDER	A/R
10	39690001-0004	SLEEVING SHRINK BLACK 1/8 ID	A/R

REVISIONS

LT#	DASH NO.	DESCRIPTION	DATE	APPROVED
		REPLACED REV J WITH CLERICAL CHANGE, FORMAT ONLY	8/28/75	MF JA
A	4005	CREATED PER ECO 73002536	8/28/75	MF JA
		REVISED PER ECO 73002770 (CLERICAL ONLY)	9/19/75	MF JA

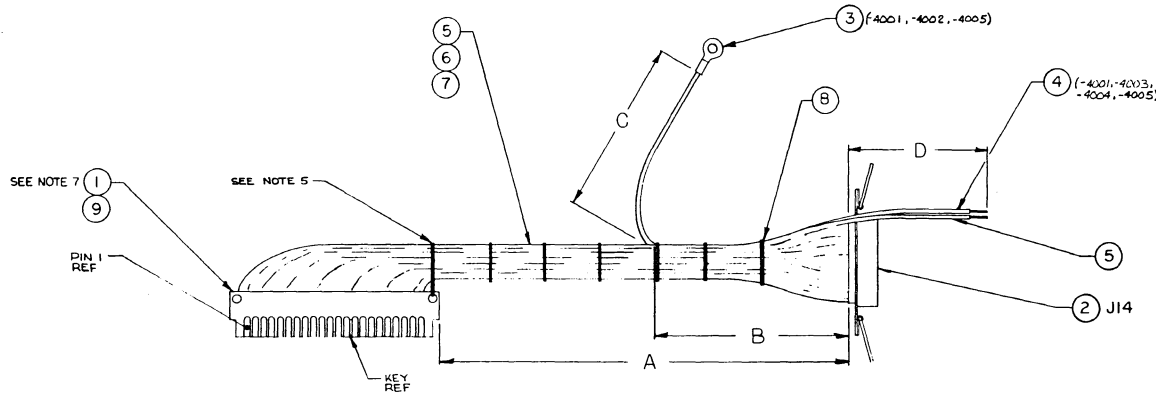

TABLE II

DASH NO.	WIRE FROM	WIRE TO
-4001	P-D	J14-35
-4002	P-D	J14-35
-4003	J14-36	J14-35
S2 TECH	P-4	J14-35
S2 TECH	P-D	J14-36
S2 TECH	P-10	P-11
-4005	P-D	J14-35

P (SEE NOTE 7)	DESCRIPTION	J14
1	YELLOW LD	33
A	YELLOW ±0V	16
2	YELLOW CHASSIS GND (4001, 4002, 4005)	17
B	LINE PULSE CNT.	34
3	RED BUSY	11
C	WHITE BUSY RETURN	29
4	LINE PULSE CNT. RET. (-4001, -4002, -4005)	35
D		36
E		
5	BACK(4001, 4003, 4004, 4005) +15 TO SPKR	34
6	YELLOW SLCT	13
F	YELLOW (SEE NOTE 6)	14
H	YELLOW OSCXT	15
B		
J		
9	YELLOW PE	12
K	WHITE (4001, 4003, 4004, 4005) TO SPKR	
10	RED IN PRIME RETURN	30
L	WHITE IN PRIME	31
11	RED DATA 6	7
N	WHITE DATA 6 RETURN	25

P (SEE NOTE 7)	DESCRIPTION	J14
12	RED DATA 8	9
R		
13	YELLOW +5V	18
P	WHITE DATA 8 RETURN	27
14		
M	YELLOW FAULT	32
15	RED DATA 5	6
S	WHITE DATA 5 RETURN	24
16	RED DATA 2	3
T	WHITE DATA 2 RETURN	21
17	RED DATA 3	4
U	WHITE DATA 3 RETURN	22
18	RED DATA 1	2
V	WHITE DATA 1 RETURN	20
19	RED DATA 7	8
W	WHITE DATA 7 RETURN	26
20	RED DATA 4	5
X	WHITE DATA 4 RETURN	23
21	RED DATA STROBE	1
Y	WHITE DATA STROBE RETURN	19
Z	RED ACKNOWLEDG	10
22	WHITE ACKNOWLEDG RETURN	28

TABLE I

DASH NO	DIM A ±1/4	DIM B ±1/4	DIM C ±1/4	DIM D ±1/4
4001	8.0	4.0	4.0	2.0
4002	11.5	6.0	5.5	—
4003	8.0	—	—	2.0
4004	8.0	—	—	2.0
4005	11.5	6.0	8.5	2.0

REVISION LEVEL OF DASH NO'S

DASH NO.	REVISION LEVEL	REMARKS
4001	J	WITH SPKR WIRES
4002	J	WITHOUT SPKR WIRES
4003	J	64 CHARA SET
4004	J	96 CHARA SET
4005	A	104

FOR LIST OF MATERIAL SEE L.M. 63002258

PRODUCTION CHANGE BY 888 ONLY

THE INFORMATION CONTAINED HEREIN IS PROPRIETARY AND IS NOT TO BE RELEASED OR REPRODUCED WITHOUT WRITTEN PERMISSION OF CENTRONICS DATA COMPUTER CORP.

CENTRONICS DATA COMPUTER CORP.  
HUBBARD, NEW HAMPSHIRE U.S.A.

CABLE ASSEMBLY, (W2)  
COMPUTER INPUT

USE OTHER PAPER SPECIFIED		APPROVAL	
1. CAPACITANCE IN PF	2. RESISTANCE IN Ω	DATE	BY
3. DIMENSIONS IN INCHES	4. TOLERANCES IN INCHES	DATE	BY
5. WEIGHT	6. FINISH	DATE	BY
7. TYPICAL	8. OTHER	DATE	BY
9. OTHER	10. OTHER	DATE	BY
11. OTHER	12. OTHER	DATE	BY
13. OTHER	14. OTHER	DATE	BY
15. OTHER	16. OTHER	DATE	BY
17. OTHER	18. OTHER	DATE	BY
19. OTHER	20. OTHER	DATE	BY
21. OTHER	22. OTHER	DATE	BY
23. OTHER	24. OTHER	DATE	BY
25. OTHER	26. OTHER	DATE	BY
27. OTHER	28. OTHER	DATE	BY
29. OTHER	30. OTHER	DATE	BY
31. OTHER	32. OTHER	DATE	BY
33. OTHER	34. OTHER	DATE	BY
35. OTHER	36. OTHER	DATE	BY
37. OTHER	38. OTHER	DATE	BY
39. OTHER	40. OTHER	DATE	BY
41. OTHER	42. OTHER	DATE	BY
43. OTHER	44. OTHER	DATE	BY
45. OTHER	46. OTHER	DATE	BY
47. OTHER	48. OTHER	DATE	BY
49. OTHER	50. OTHER	DATE	BY
51. OTHER	52. OTHER	DATE	BY
53. OTHER	54. OTHER	DATE	BY
55. OTHER	56. OTHER	DATE	BY
57. OTHER	58. OTHER	DATE	BY
59. OTHER	60. OTHER	DATE	BY
61. OTHER	62. OTHER	DATE	BY
63. OTHER	64. OTHER	DATE	BY
65. OTHER	66. OTHER	DATE	BY
67. OTHER	68. OTHER	DATE	BY
69. OTHER	70. OTHER	DATE	BY
71. OTHER	72. OTHER	DATE	BY
73. OTHER	74. OTHER	DATE	BY
75. OTHER	76. OTHER	DATE	BY
77. OTHER	78. OTHER	DATE	BY
79. OTHER	80. OTHER	DATE	BY
81. OTHER	82. OTHER	DATE	BY
83. OTHER	84. OTHER	DATE	BY
85. OTHER	86. OTHER	DATE	BY
87. OTHER	88. OTHER	DATE	BY
89. OTHER	90. OTHER	DATE	BY
91. OTHER	92. OTHER	DATE	BY
93. OTHER	94. OTHER	DATE	BY
95. OTHER	96. OTHER	DATE	BY
97. OTHER	98. OTHER	DATE	BY
99. OTHER	100. OTHER	DATE	BY

7. DESIGNATED P4 FOR 101, 101A, 102A, 102AL, 104. DESIGNATED P7 FOR 101AL, 101AL(H), 306, 500.
6. FOR -4001, -4002, -4005 FUNCTION TO BE SS. FOR -4003, -4004 FUNCTION TO BE BOTFRM.
5. TIE CABLE OFF WITH LACING CORD AT FINGER BOARD FOR STRAIN RELIEF
4. LEADS SHOWN WITH SYMBOL SIGNIFY TWISTED PAIR
3. ALL WIRE IS NO. 26 AWG 7/34 STRANDED
2. STRIP ALL LEADS .25 ON BOTH ENDS AND TIN BEFORE ASSEMBLY.
- NOTES:

Figure 7-20. CABLE ASS'Y, COMPUTER INPUT

LIST OF MATERIALS  
W2 CABLE ASSEMBLY  
(Reference: Ass'y #63002258-4003, Rev. J)

ITEM	PART NO.	NOMENCLATURE	QTY PER
1	63001024-2001	PC BD AW PARALLEL TIMER FIN BD	1
2	31310019-1016	CONN 36 CONTACT NOT KEYED	1
3	31460000-2003	TERMINAL RING NO 8 22-24 AWG	1
5	39648505-0004-9	WIRE TYPE B 26AWG WHITE	A/R
6	39648505-0004-4	WIRE TYPE B 26AWG YELLOW	A/R
7	39648505-0004-2	WIRE TYPE B 26AWG RED	A/R
8	39690000-0001	TAPE LACING WHITE .010X1/16W	A/R
9	30070000-0001	SOLDER	A/R
REF	63001025-9001	PC BD DD PARALLEL TIMER FIN BD	A/R

SECTION 8  
MECHANICAL DRAWINGS AND PARTS LISTS

This section contains drawings and parts lists for the following major mechanical assemblies in the 306 printer and is updated for Rev. E.

<u>Figure</u>	<u>Reference Designation</u>	<u>Description</u>
8-i	-	Location of Model 306 Subassemblies
8-1	AA	Carriage
8-2	AB	Platen
8-3	AC	Paper Pan
8-4	AD	Driving Mechanism (1)
8-5	AE	Driving Mechanism (2) (Air-Gap Clutch)
8-5A	AE	Driving Mechanism (2) (Preload Clutch)
8-6	AF	Idler Pulley
8-7	AG	Reed Switch
8-8	AH	Base
8-9	AI	Frame
8-10	AJ	Paper Feed
8-11	AK	Pin Feed
8-12	AL	Ribbon Feed (Part 1 of 2)
8-13	AL	Ribbon Feed (Part 2 of 2)
8-14	AM	Cover
8-15	AN	Operator Panel
8-16	AO	Electrical Components (1)
8-17	AP	Electrical Components (2)
8-18	AQ	Electrical Components (3)
8-19	-	Print Head and Associated Assemblies
8-20	-	Tape Reader Assembly (Option)
8-20A	-	Tape Reader Assembly (Alternate item)

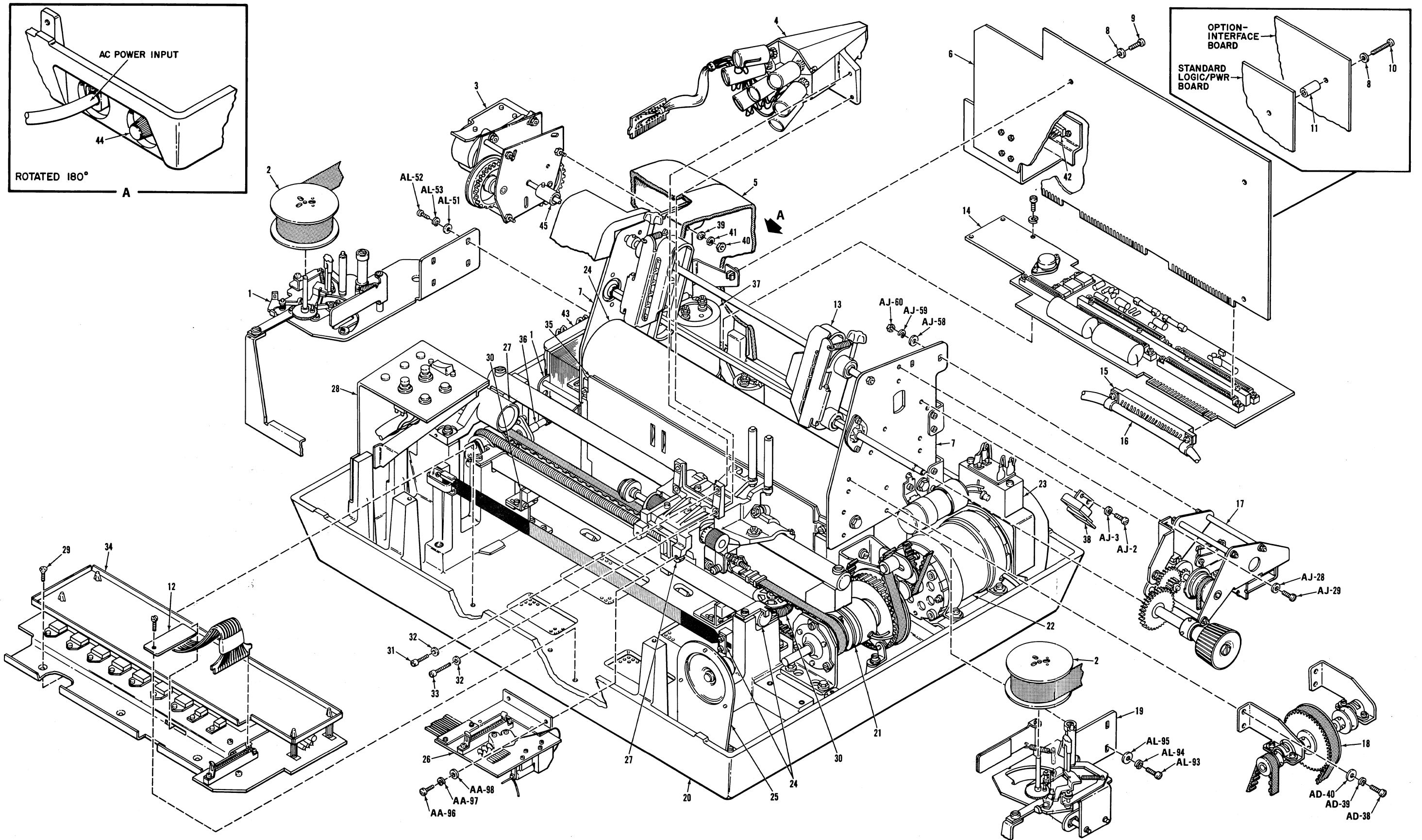

Figure 8-i. MODEL 306 SUBASSEMBLIES

Figure 8-1. MODEL 306 SUBASSEMBLIES

<u>KEY NO.</u>	<u>FIGURE</u>	<u>DESCRIPTION</u>
1	8-12	Ribbon Feed - AL (Part 1 of 2)
2	8-12	Twin Spool with Ribbon - AL-113
3	8-20	Vertical Format Unit (Option)
4	7-1	Head Ass'y, Fig. 8-19
5	8-14	Cover - AM
6	7-14	Logic/Power Supply Ass'y
7	8-9	Frame - AI
8	8-9	Frame - (AI-C)
9	8-9	Frame - (AI-B)
10	8-9	Frame - (AI-E)
11	8-9	Frame - (AI-D)
12	8-19	See Item 37
13	8-11	Pin Feed - AK
14	7-19	Connector Board 63060109 - See also Fig. 7-15
15	7-13	Main Harness Connector (J8) - See also Fig. 8-18
16	7-12	Main Harness 526783001 - See also Fig. 8-18
17	8-10	Paper Feed - AJ
18	8-4	Driving Mechanism (Part 1 of 2) - AD
19	8-12	Ribbon Feed (Part 1 of 2) - AL
20	8-8	Base - AH
91	8-5	Driving Mechanism - AE (part 1) or AE (part 2)
22	8-4	Driving Mechanism (Part 1 of 2) - AD
23	5-25	Motor Control Unit (Option)
24	8-2	Platen - AB
25	8-8	Speaker (Option) - AH
26	7-18	Video Amplifier Ass'y (See also Fig. 8-19, item 26)
27	8-1	Carriage - AA
28	8-15	Operator Panel - AN
29	808	Base - (AH-12)
30	8-7	Reed Switch - AG
31	8-19	Print Head and Associated Assemblies, item 16
32	8-19	Print Head and Associated Assemblies, item 17
33	8-19	Print Head and Associated Assemblies, item 18
34	7-16	Power Driver Board Assembly (See also Fig. 8-19/33)
35	8-3	Paper Pan - AC
36	8-6	Idler Pulley - AF
37	8-17	Electrical Components (Part 2 of 3)
38	8-10	Paper Feed (AJ-1)
39	8-20	Vertical Format Unit (VFU - Option) (Kit Item 5)
40	8-20	Vertical Format Unit (VFU - Option) (Kit Item 8)
41	8-20	Vertical Format Unit (VFU - Option) (Kit Item 6)
42	7-21	Cable Ass'y, Data Input
43	8-16	Transformer Unit (AO)
44	8-16	In-Line Fuse, 3-Amp, Slo-Blo (AO), See item 42 and 42-1
45	8-20	Refer to item 9 of VFU Kit

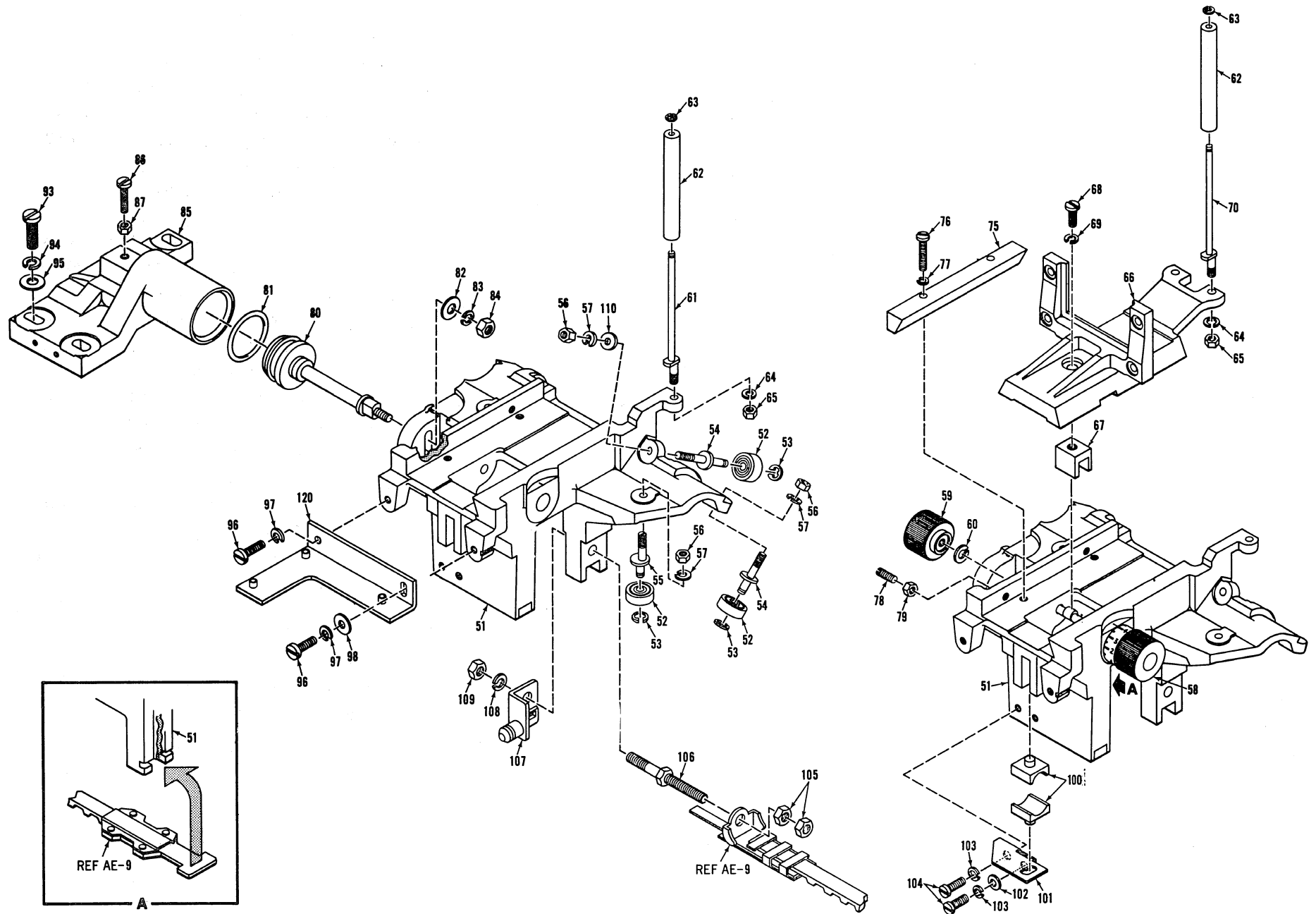

Figure 8-1. CARRIAGE - AA



Figure AA Carriage

Reference Number	Part Number	Part Name	Quantity
AA-0	526872001	Carriage Unit Note: This unit is assembled with parts covering from reference number AA-51 through AA-65.	1
AA-00	526871001	Carriage, complete unit Note: This unit is assembled with parts covering from reference number AA-0 through AA-79 and AA-101 through AA-109, except AA-105.	1
AA-51	526873001	Carriage	1
AA-52	527242001	Roller	6
AA-53	048030346	Snap ring	6
AA-54	526875001	Axle for AA-52	4
AA-55	526876001	Eccentric Axle for AA-52	2
AA-56	021400106	Nut for AA-54, 55	6
AA-57	028040247	Spring washer for AA-54, 55	6
AA-58	525544001	Head adjusting knob	1
AA-59	525025001	Head lock knob	1
AA-60	028040247	Spring washer for AA-59	1
AA-61	526877001	Carriage ribbon guide axle	1
AA-62	526878000	Ribbon guide roller	2
AA-63	048020346	Snap ring for AA-61, AA-70	2
AA-64	028040247	Spring washer for AA-61, AA-70	2
AA-65	021400106	Nut for AA-61, AA-70	2
AA-66	526947000	Head bracket	1
AA-67	525002001	Fork for head adjustment	1
AA-68	007400716	Screw for AA-67	1
AA-69	028040247	Spring washer for AA-68	1
AA-70	526910001	Head ribbon guide axle	1
AA-75	525047000	Head bracket guide	1
AA-76	007301416	Screw for AA-75	2
AA-77	028030247	Spring washer for AA-76	2

Figure AA Carriage

Reference Number	Part Number	Part Name	Quantity
AA-78	011401016	Screw for AA-75	2
AA-79	021400106	Nut for AA-78	2
AA-80	527575001	Piston unit	1
AA-81	081021070	O-ring for AA-80	1
AA-82	025050236	Washer for AA-80	1
AA-83	028050247	Spring washer for AA-80	1
AA-84	021500106	Nut for AA-80	1
AA-85	527571000	Damper cylinder	1
AA-86	007401416	Screw for AA-85	1
AA-87	021400106	Nut for AA-86	1
AA-93	007501816	Screw for AA-85	3
AA-94	025050236	Washer for AA-93	3
AA-95	028050247	Spring washer for AA-93	3
AA-96	007400816	Screw for video amp. bracket	2
AA-97	028040247	Spring washer for AA-96	2
AA-98	025040236	Washer for AA-96	1
AA-100	526937001	Retainer	2
AA-101	526936001	Retainer holder	1
AA-102	025040236	Washer for AA-101	1
AA-103	028040247	Spring washer for AA-104	2
AA-104	007400716	Screw for AA-101	2
AA-105	021500106	Nut for AA-106	2
AA-106	526879001	Belt tension axle	1
AA-107	526880001	D.B. Guide plate	1
AA-108	028050247	Spring washer for AA-106	1
AA-109	021500106	Nut for AA-106	1
AA-110	025040136	Washer for AA-54	1
120	63060107-4001	Reference item 21, Video Amp. bracket - Section 7	1

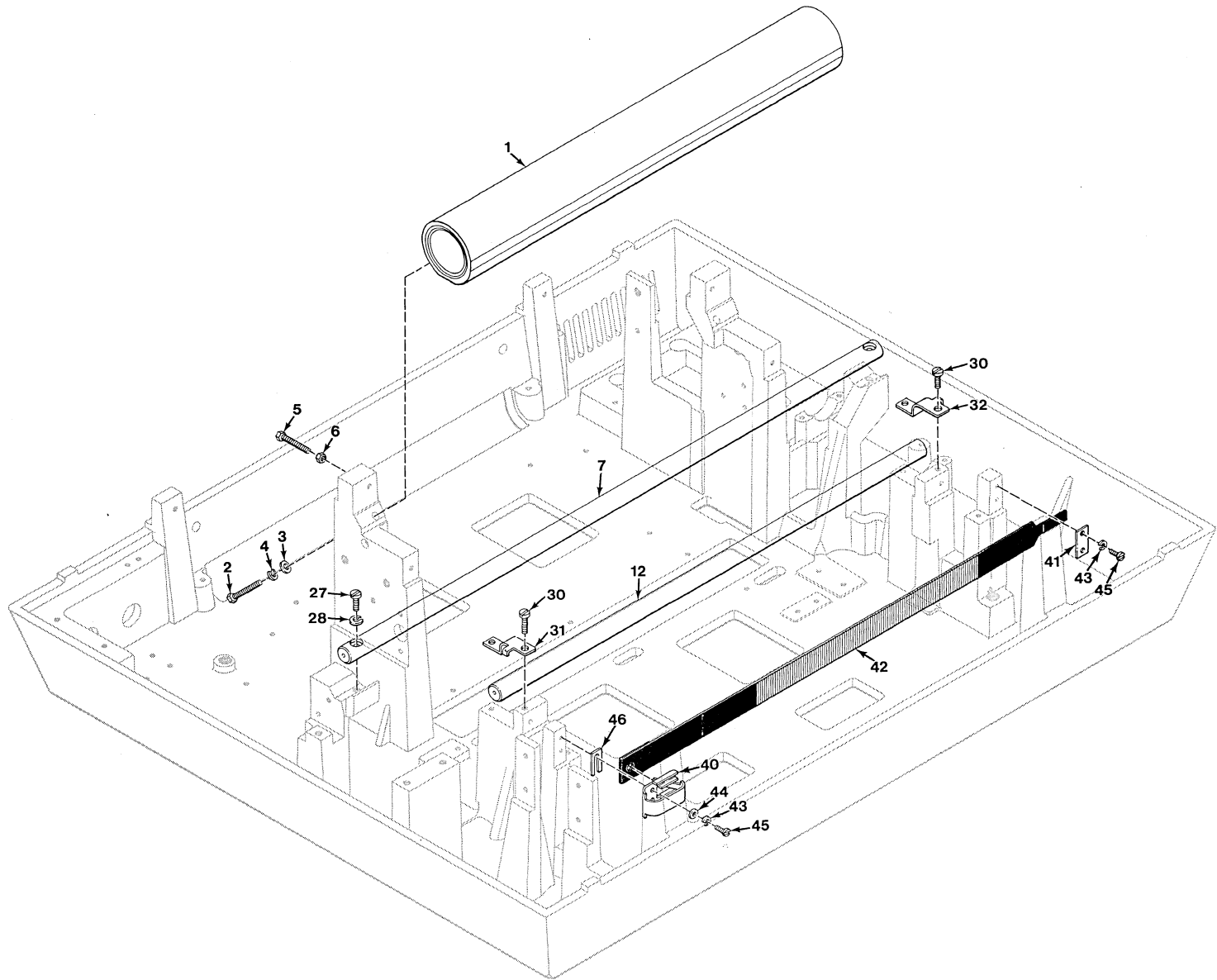

Figure 8-2. PLATEN - AB

Figure AB Platen

Reference Number	Part Number	Part Name	Quantity
AB-1	526722001	Platen	1
AB-2	017402216	Screw for AB-1	2
AB-3	025040236	Washer for AB-2	2
AB-4	028040247	Spring Washer for AB-2	2
AB-5	017402216	Screw for AB-1	2
AB-6	021400106	Nut for AB-5	2
AB-7	526919001	Guide Bar for Carriage (Rear)	1
AB-12	526920001	Guide Bar for Carriage (Front)	1
AB-27	007502016	Screw for AB-7	2
AB-28	028050247	Spring Washer for AB-27	2
AB-30	007401016	Screw for 31, AB-32	4
AB-31	526960001	Guide Bar Set Plate (L)	1
AB-32	526961001	Guide Bar Set Plate (R)	1
	63060194-6001	Timing Fence Kit (Series 300)	1
		Note: This unit is assembled with items 40 through 43, 44, 45 and 46.	
40	63508140-2001	Clasp Timing Fence	1
41	63508106-2001	Clamp Timing Fence	1
42	63060179-5001	Timing Fence Ass'y, 80 Char. 306	1
43	34000032-2001	Washer M3 Lock	4
43A	028030247-2001	Washer Spring (Alternate)	AR
44	34000052-2001	Washer	2
44A	025030236-2001	Washer (Alternate)	AR
45	34000048-2001	Screw M3 P0.5 x 6 MM Filister	4
45A	001300716-2001	Screw	AR
45B	34000091-2001	Screw M3 x P0.5 X 6 MM Lg Pan/Slot	AR
46	63500113-2001	Timing Fence Shim	AR

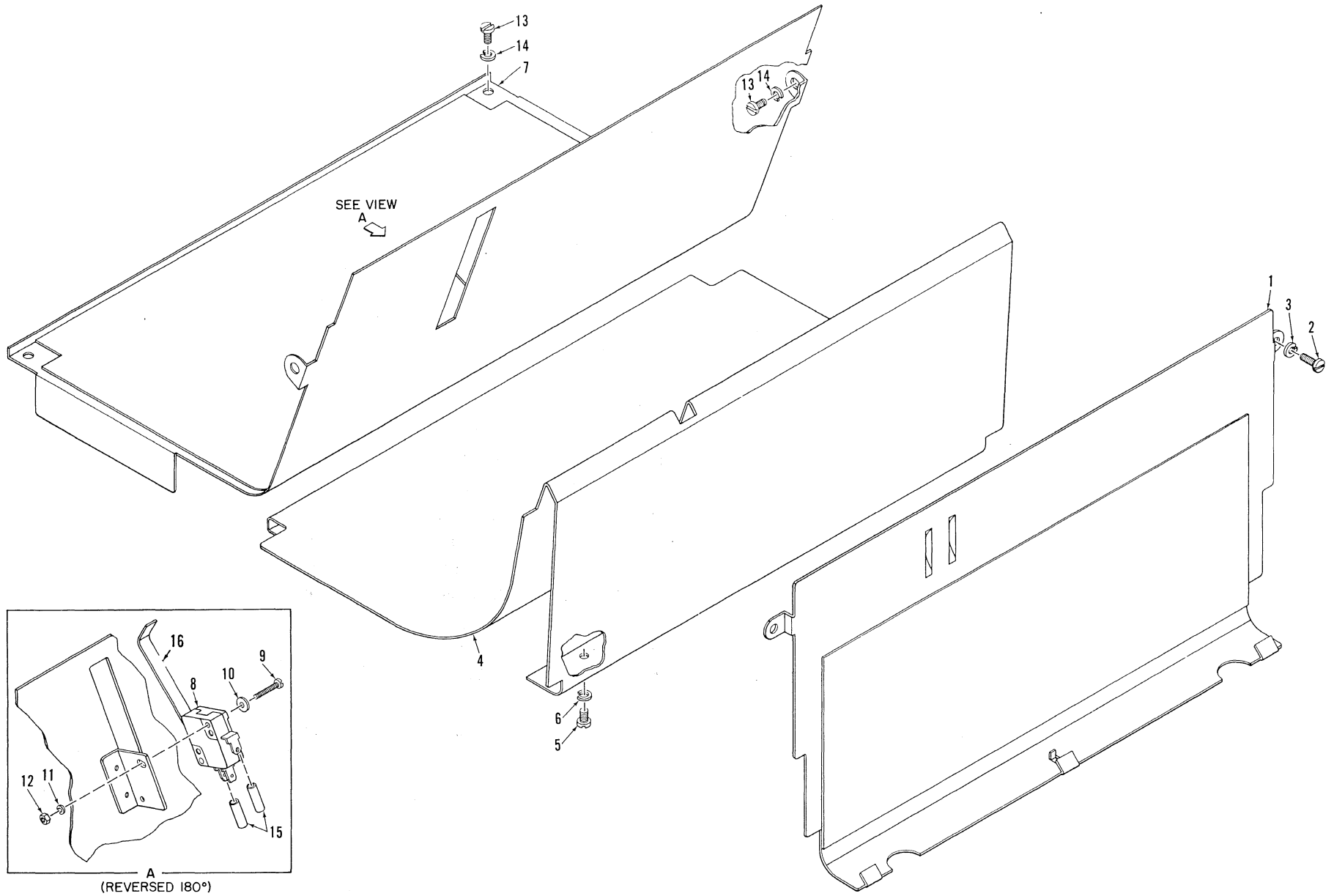

Figure 3-3. PAPER PAN - AC

## Figure AC Paper Pan

Reference Number	Part Number	Part Name	Quantit
AC-1	526520001	Paper pan unit (front)	1
AC-2	007400716	Screw for AC-1	2
AC-3	028040247	Spring washer for AC-2	2
AC-4	526526001	Paper pan unit (center)	1
AC-5	007400716	Screw for AC-4	3
AC-6	028040247	Spring washer for AC-5	3
AC-7	526530001	Paper pan unit (rear)	1
AC-8	527237001	Micro-switch	1
AC-9	007021616	Screw for AC-8	2
AC-10	025630236	Washer for AC-9	2
AC-11	028020247	Spring washer for AC-9	2
AC-12	021020106	Nut for AC-9	2
AC-13	007400716	Screw for AC-7	4
AC-14	028040247	Spring washer for AC-13	4
AC-15	525675001	Insulating tube	2
AC-16	526940001	Actuator arm for item AC-8	1
	526992001	Micro-switch unit	1

Note: This unit assembled with parts covering AC-8 and AC-16.

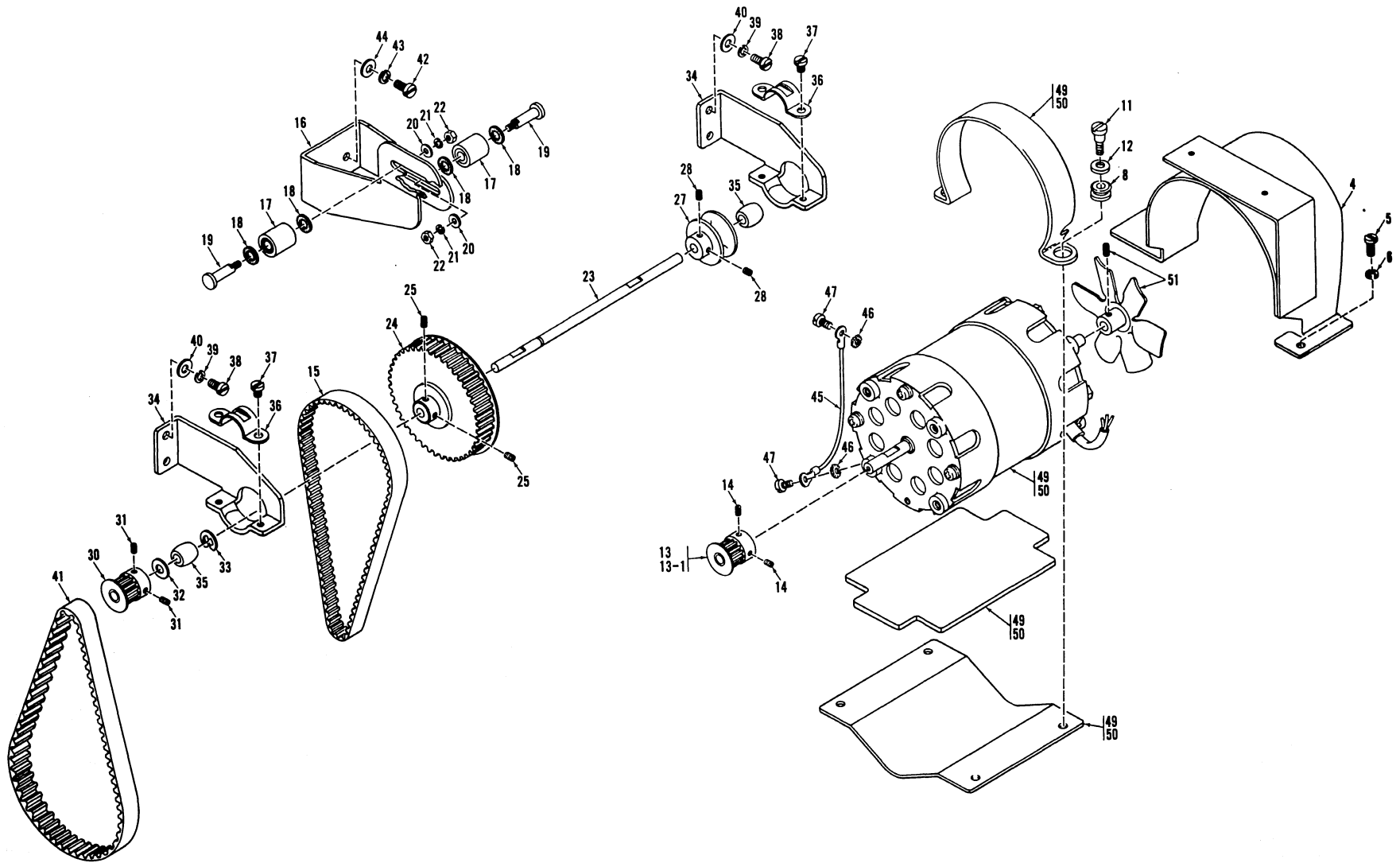

Figure 8-4. DRIVING MECHANISM (PART 1 OF 2) - AD

Rev. B

Figure AD Driving Mechanism - Part 1

Reference Number	Part Number	Part Name	Quantity
AD-4	526778001	Motor Fan Cover	1
AD-5	007400716	Screw for AD-4	1
AD-6	028040247	Spring Washer for AD-5	1
AD-8	510101001	Grommet for AD-7	4
AD-11	526645001	Screw for AD-7	4
AD-12	510061001	Washer for AD-11	4
AD-13	526509001	Motor Pulley (60 Hz)	1
AD-13-I	526508001	Motor Pulley (50 Hz) (Option)	1
AD-14	525744991	Screw for AD-13	2
AD-15	526746001	Timing Belt 140-L	1
AD-16	526923001	Tensioner Bracket	1
AD-17	525703001	Tensioner (L)	2
AD-18	51146001	Felt Washer	4
AD-19	526649001	Screw (L)	2
AD-20	025030133	Washer for AD-19	2
AD-21	028030247	Spring Washer for AD-19	2
AD-22	021300106	Nut for AD-19	2
AD-23	526633001	Center Shaft	1
AD-24	526628001	Center Pulley	1
AD-25	525743001	Set-Screw for AD-24	2
AD-27	526926001	Driving Pulley	1
AD-28	525743001	Set-Screw for AD-27	2
AD-30	526509001	Motor Pulley	1
AD-31	525744001	Screw for AD-30	2
AD-32	526634001	Washer for AD-30	1
AD-33	048050346	Snap Ring for AD-23	1
AD-34	526925001	Bracket for AD-23	2
AD-35	526681001	Retainer (B)	2
AD-36	526637001	Retainer Bracket	2
AD-37	007400416	Screw for AD-36	4
AD-38	007400816	Screw for AD-34	4

8-12

Figure AD Driving Mechanism - Part 1

Reference Number	Part Number	Part Name	Quantity
AD-39	028040247	Spring Washer for AD-38	4
AD-40	025040236	Washer for AD-38	4
AD-41	526747001	Timing Belt 150-L	1
AD-42	007401016	Screw for AD-16	2
AD-43	028040247	Spring Washer for AD-42	2
AD-44	025040236	Washer for AD-42	2
AD-45	515456001	Ground Wire for AD-1	1
AD-46	550719001	External Lock-Washer for AD-45	2
AD-47	007400516	Screw for AD-45	2
AD-49	526986001	Motor Set (110V, 50/60 Hz) standard, includes mtg. set, also motor requires no P.M. - (Long life ball bearings).	1
AD-50	526987001	Motor Set (220V, 50/60 Hz) Option, includes mtg. set, also motor requires no P.M. (Long life ball bearings).	1
AD-51	526994001	Main Motor Fan and Set-Screw, used for AD-49 and AD-50.	1

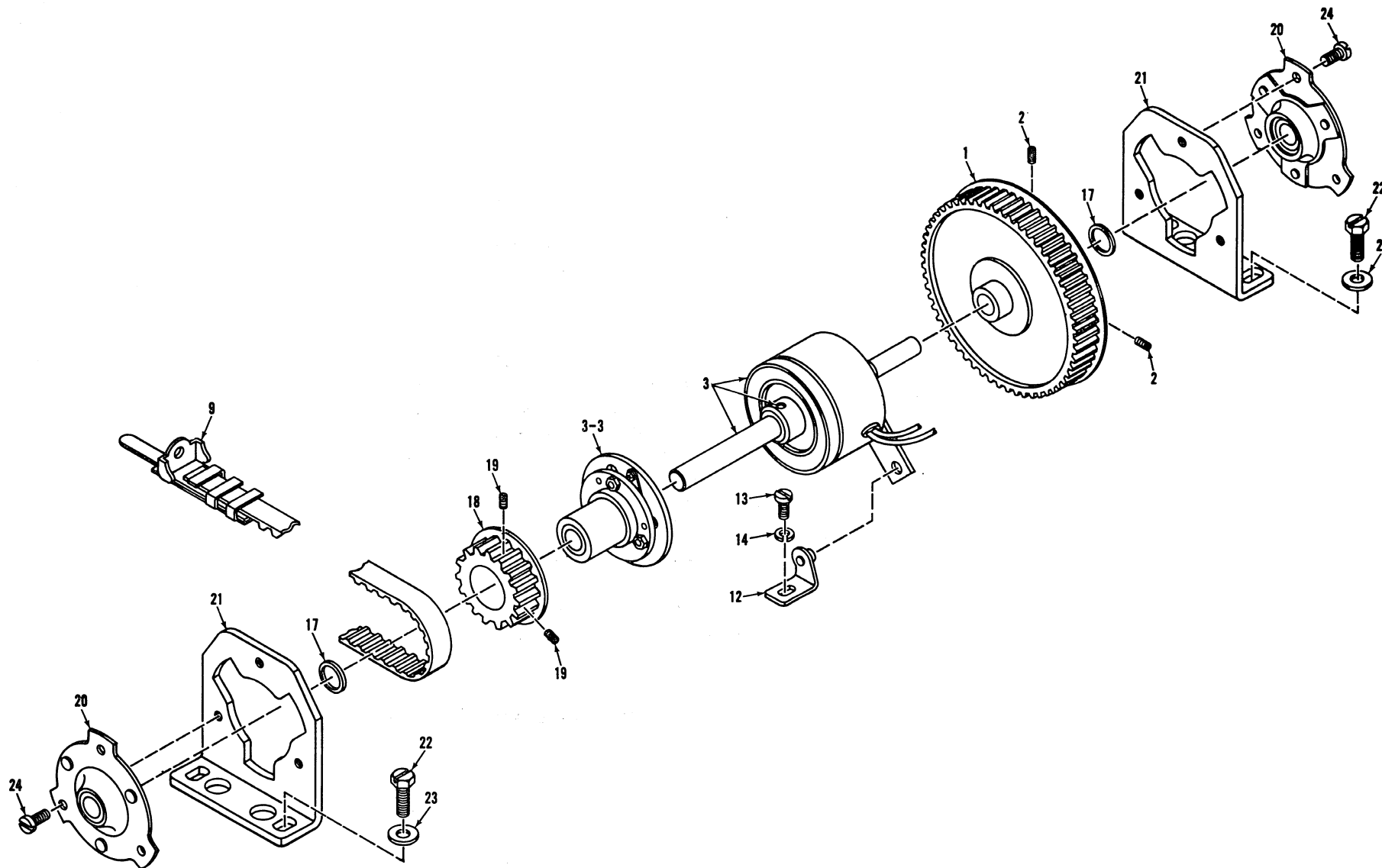

Figure 8-5. DRIVING MECHANISM (AE, PART 2) (THIS DRAWING APPLIES TO AIR-GAP CLUTCH ONLY)



Figure AE DRIVING MECHANISM (1) (AIR-GAP)

Reference Number	Part Number	Part Name	Quantity
AE-1	526643001	Driving pulley	1
AE-2	525744001	Set-screw for AE-1	2
*AE-3	526860001	Electromagnetic clutch unit	1
		Note: This unit includes rotor, shaft, clutch field ass'y, and spring pin.	
*AE-3-3	526715001	Clutch armature	1
AE-9	526882001	Driving belt unit	1
AE-12	525631001	Clutch turning stopper (L)	1
AE-13	007400616	Screw for AE-12	1
AE-14	025040236	Washer for AE-13	1
AE-17	526943001	Spacer	2
AE-18	526950001	Driving pulley (C)	1
AE-19	525743001	Set-screw for AE-18	2
AE-20	525092001	Bushing unit	2
AE-21	525090001	Bushing bracket	2
AE-22	525752001	Bolt for AE-21	4
AE-23	025060236	Washer for AE-22	4
AE-24	007400616	Screw for AE-21	6

\*When using an air-gap clutch assembly (AE-3-3 and AE-3), use power driver board 63060105-1 only.

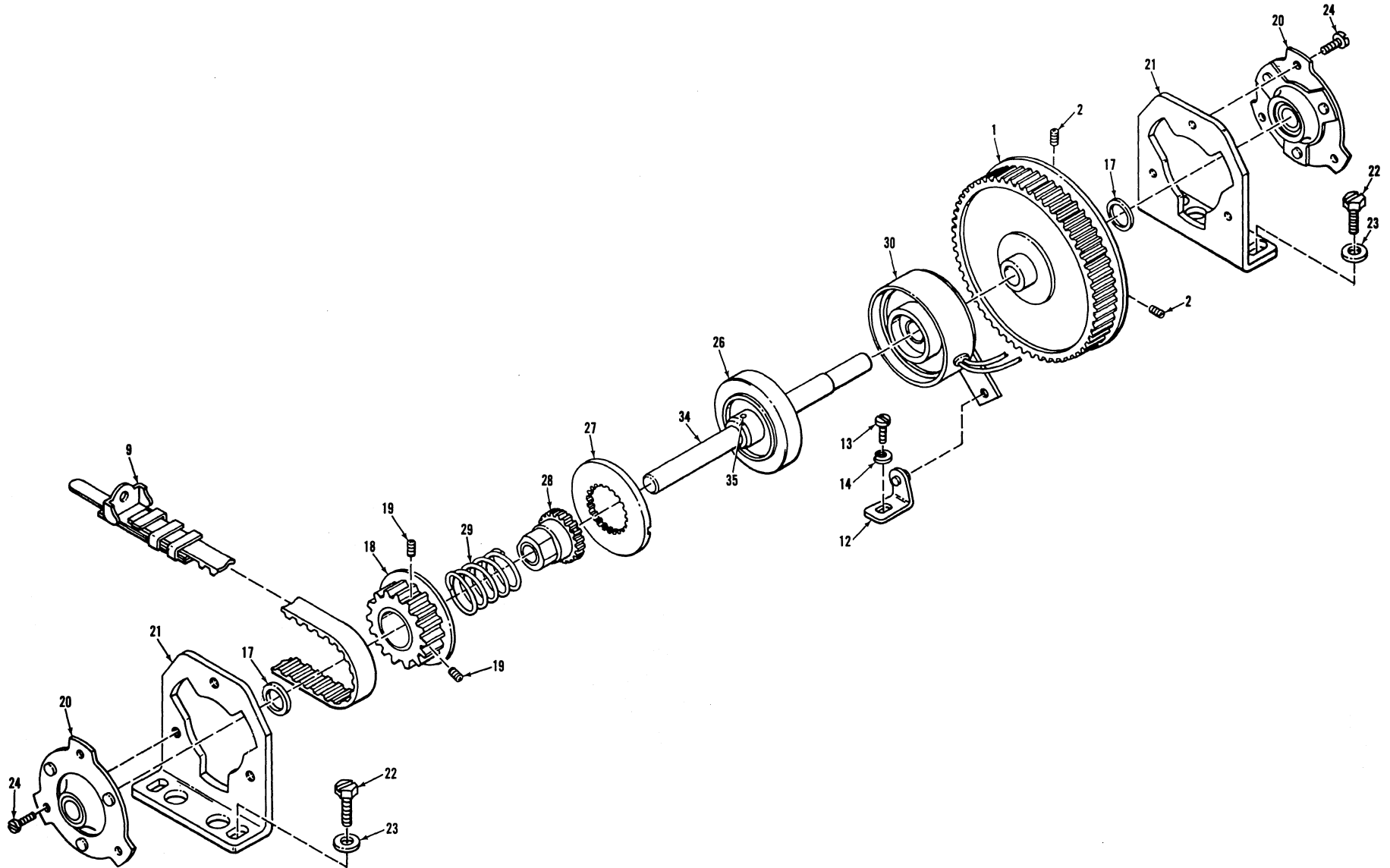

Figure 8-5A. DRIVING MECHANISM (AE, PART 2) (THIS DRAWING APPLIES TO PRELOAD CLUTCH ONLY)

Figure AE DRIVING MECHANISM (2)

(This Parts List Applies to Preload Clutch Only)

Reference Number	Part Number	Part Name	Quantity
AE-1	526643001	Driving pulley	1
AE-2	525744001	Set-screw for AE-1	2
AE-9	526882001	Driving belt unit	1
AE-12	525631001	Clutch turning stopper (L)	1
AE-13	007400616	Screw for AE-12	1
AE-14	025040236	Washer for AE-13	1
AE-17	526943001	Spacer	2
AE-18	526950001	Drive Pulley (C)	1
AE-19	525743001	Set-screw for AE-18	2
AE-20	525092001	Bushing unit	2
AE-21	525090001	Bushing bracket	2
AE-22	525752001	Bolt for AE-21	4
AE-23	025060236	Washer for AE-22	4
AE-24	007400616	Screw for AE-20	6
AE-26	527678001	Clutch rotor	1
AE-27	527680001	Clutch armature	1
AE-28	527681001	Hub	1
AE-29	527679001	Clutch spring	1
AE-30	526717001	Clutch field assembly	1
AE-34	526642001	Shaft (Short with pinned rotor)	1
AE-35	047401842	Spring pin	1
*AE-36	529019001	Pre-load clutch complete unit	1

Note: This unit is assembled with parts covering from reference number AE-26 through AE-30 and AE-34, 35.

\*When using a preload clutch assembly (AE-36) in Model 306, apply power driver board assembly 63060105-5 (Refer to Section 7) configured especially for splined clutch operation (preload) and for four or eight inches per second (IPS) paper slew speed.

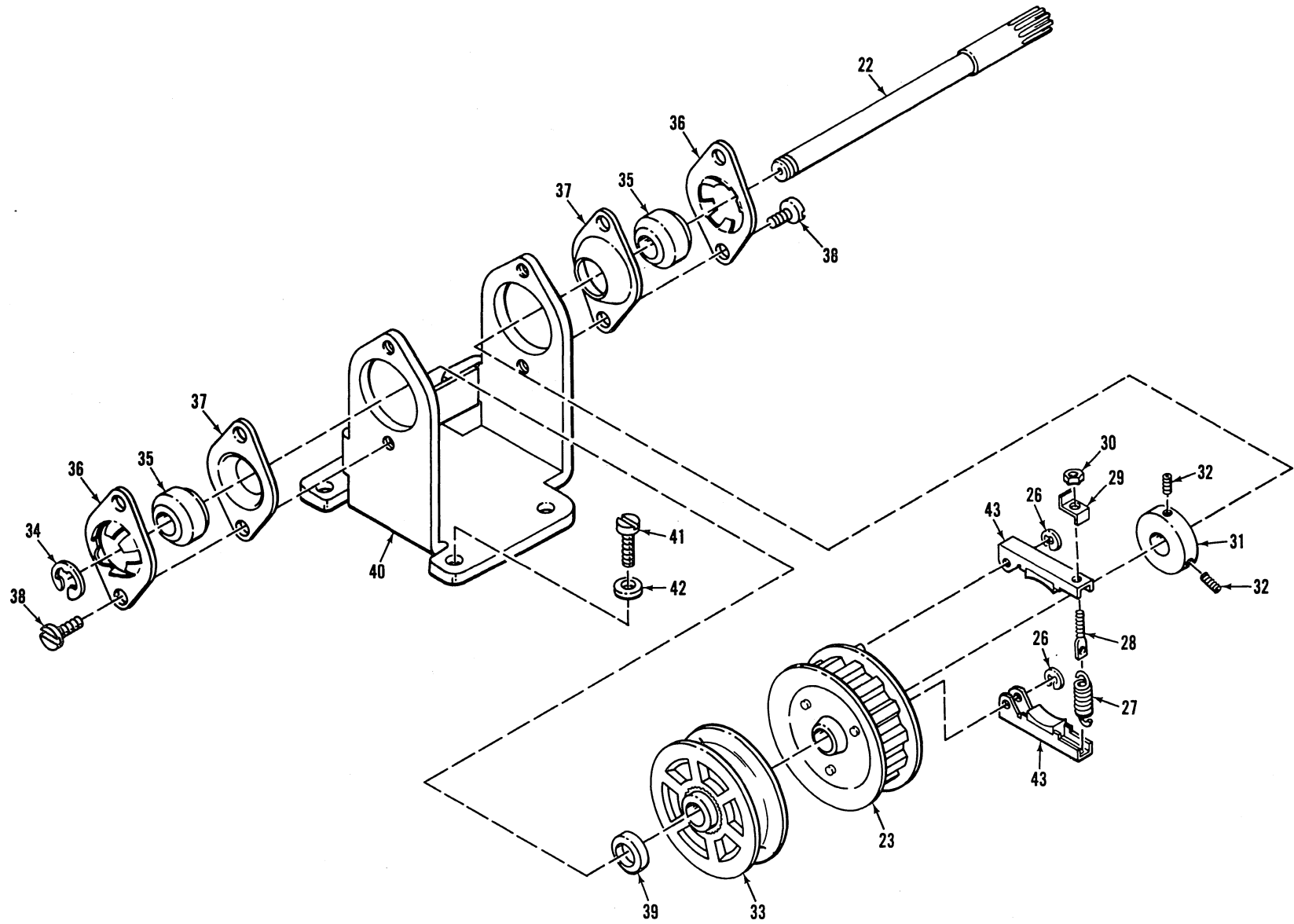

Figure 8-6. IDLER PULLEY - AF

Figure AF IDLER PULLEY

Reference Number	Part Number	Part Name	Quantity
AF-21	527730001	Idler pulley assembly Note: This unit is assembled with parts covering from reference AF-22, 23, and 26 to AF-43.	1
AF-22	5277729001	Idler pulley shaft	1
AF-23	527688001	Idler pulley	1
AF-26	048020346	Snap ring	2
AF-27	527701001	Spring for AF-43	1
AF-28	527702001	Ti.reamed shaft for AF-26	1
AF-29	527703001	Nut holder	1
AF-30	021300113	Nut	1
AF-31	527704001	Friction sleeve	1
AF-32	525744001	Screw	2
AF-33	526655000	Return pulley	1
AF-34	048060346	Snap ring for AF-22	1
AF-35	526680001	Retainer (C)	2
AF-36	525209001	P.F. retainer	2
AF-37	525207001	Holder	2
AF-38	007400516	Screw	4
AF-39	526917001	Spacer	1
AF-40	526904001	Idler pulley holder	1
AF-41	007400816	Screw for AF-40	4
AF-42	028040247	Spring washer for AF-41	4
AF-43	529214001	Brake Shoe Holder (includes attached brake shoe)	2

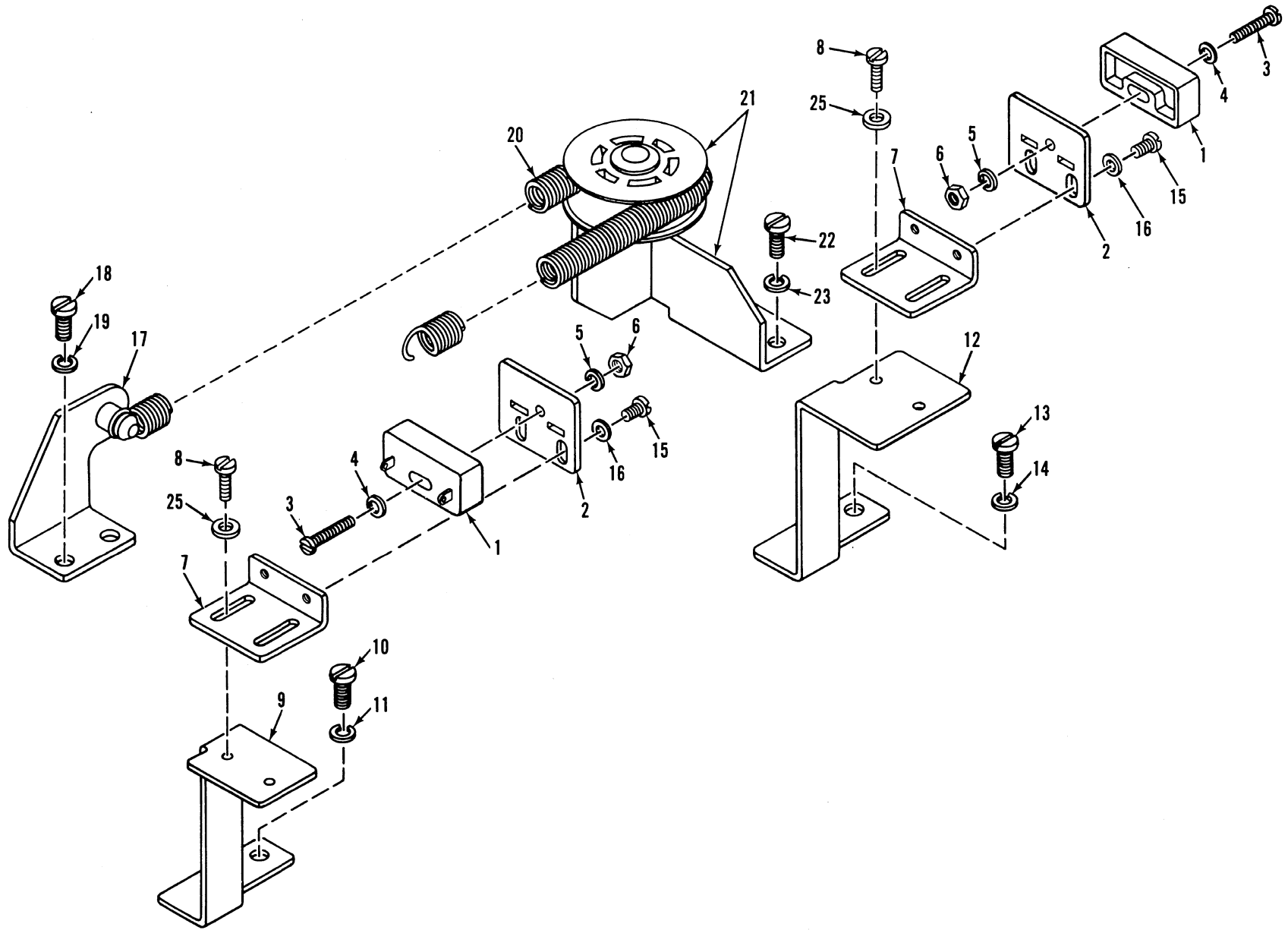

Figure 8-7. REED SWITCH - AG

Figure AG Reed Switch

Reference Number	Part Number	Part Name	Quantity
AG-1	525721001	Reed switch (Left and Right)	2
AG-2	525725001	Adjusting holder for AG-1	2
AG-3	001301403	Screw for AG-1	2
AG-4	025030133	Washer for AG-3	2
AG-5	028030247	Spring washer for AG-3	2
AG-6	021300106	Nut for AG-3	2
AG-7	525169001	Reed switch holder	2
AG-8	007300716	Screw for AG-7, 9	4
AG-9	526911001	Reed switch holder (L)	1
AG-10	007400816	Screw for AG-9	2
AG-11	028040247	Spring washer for AG-9	2
AG-12	526912001	Reed switch holder (R)	1
AG-13	007400816	Screw for AG-12	2
AG-14	028040247	Spring washer for AG-13	2
AG-15	007300516	Screw for AG-2, 7	4
AG-16	025030133	Washer for AG-15	4
AG-17	526756001	Return spring holder	1
AG-18	007400816	Screw for AG-17	2
AG-19	028040247	Spring washer for AG-18	2
AG-20	526663001	Spring (carriage return)	1
AG-21	526710001	Return idler and holder	1
AG-22	007400816	Screw for AG-21	2
AG-23	028040247	Spring washer for AG-22	2
AG-25	025030236	Washer for AG-8	4

8-21

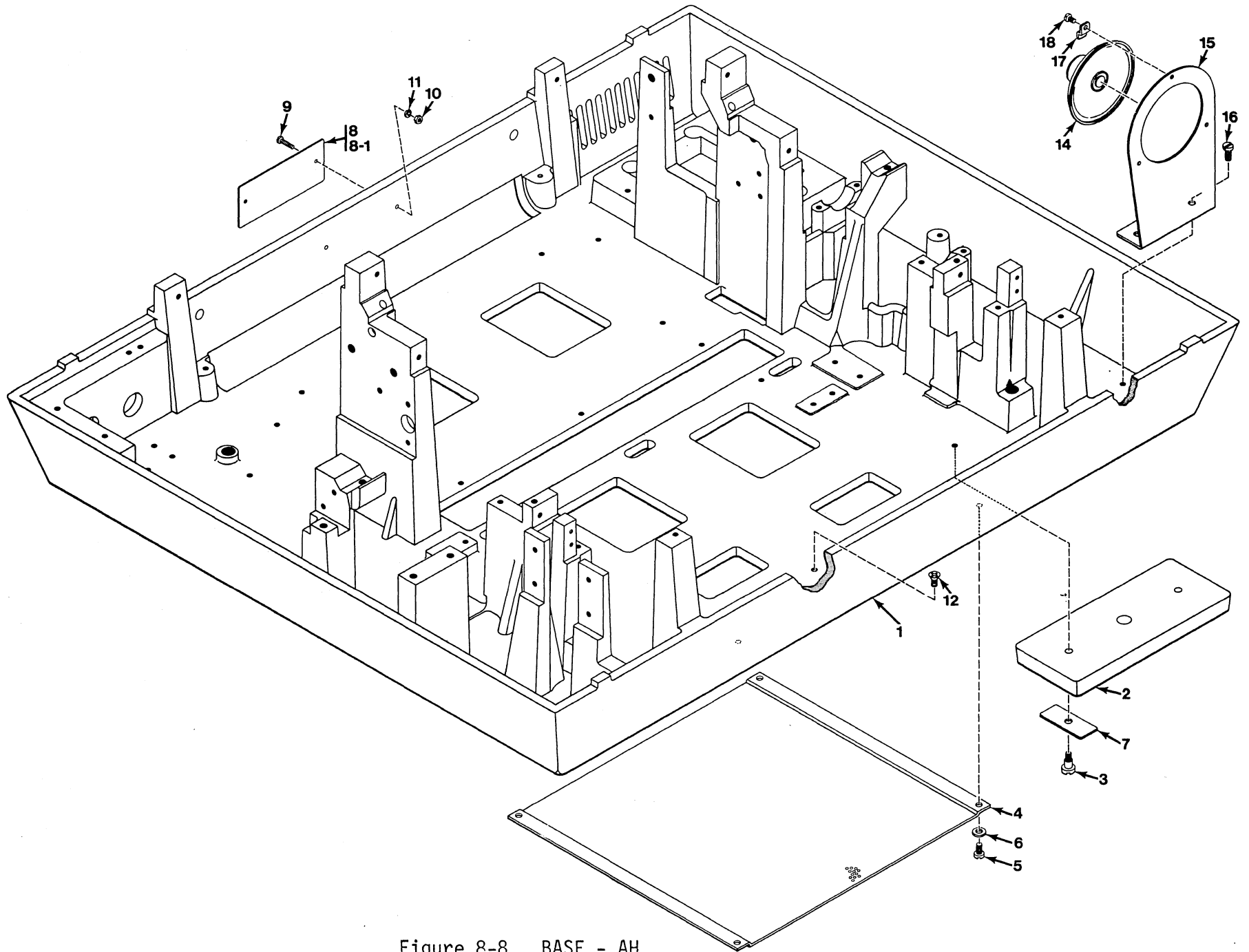

Figure 8-8. BASE - AH

Rev. B



Figure AH Base

Reference Number	Part Number	Part Name	Quantity
AH-1	526962001	Base	1
AH-2	526739001	Rubber Foot	4
AH-3	526740001	Screw for AH-2	8
AH-4	526753001	Bottom Plate	1
AH-5	007400816	Screw for AH-4	4
AH-6	025040236	Washer for AH-5	4
AH-7	526741001	Plate for AH-2	8
AH-8	526816001	Rating Plate 110V -120V	1
AH-8-1	526954001	Rating Plate 220V -240V	1
AH-9	001021014	Screw for AH-8, 8-1	2
AH-10	021020106	Nut for AH-8, 8-1	2
AH-11	028020247	Spring Washer	2
AH-12	004400816	Mtg Screw for Power Driver Board 63060105 (Refer to Fig. 7-16)	3
	63060189-6001	Speaker Unit (Option) Kit	1
		Note: Assembled with reference No's AH-13 through AH-18.	
AH-13	526825001	Speaker and bracket ass'y	1
AH-14	526824001	Speaker	1
AH-15	526766001	Speaker Bracket	1
AH-16	007400816	Screw for AH-15	2
AH-17	526767001	Clamp for AH-14	3
AH-18	007300416	Screw for AH-17	3

8-23

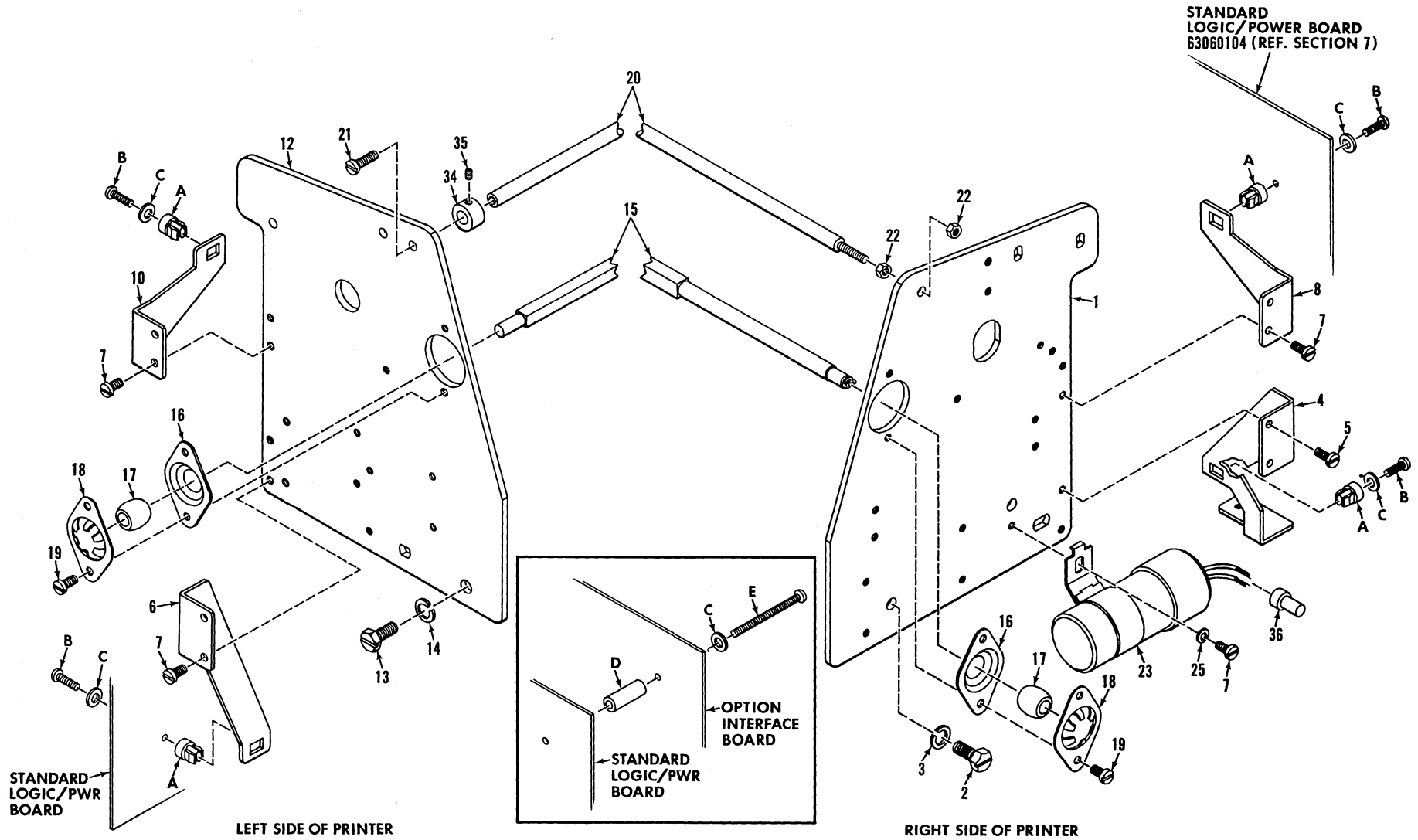

Figure 8-9. FRAME - AI

Rev. B

Figure AI Frame

Reference Number	Part Number	Part Name	Quantity
AI-1	526545001	Frame (R)	1
AI-2	525752001	Bolt for AI-1	2
AI-3	028060247	Spring Washer for AI-2	2
AI-4	526705001	PC Board Holder (RL)	1
AI-5	007400416	Screw for AI-4	2
AI-6	526706001	PC Board Holder (LL)	1
AI-7	007400816	Screw for AI-6, 8, 10, 23	7
AI-8	526707001	PC Board Holder (RU)	1
AI-10	526708001	PC Board Holder (LU)	1
AI-12	526546001	Frame (L)	1
AI-13	525752001	Bolt for AI-12	2
AI-14	028060247	Spring Washer for AI-13	2
AI-15	526538001	Paper Feed Shaft	1
AI-16	525207001	Retainer Holder (A)	2
AI-17	525208001	Retainer (D)	2
AI-18	525209001	Retainer Holder (B)	2
AI-19	007400516	Screw for AI-1, 12	4
AI-20	526539001	Paper Feed Guide Shaft	1
AI-21	007401016	Screw for AI-20	1
AI-22	021400106	Nut for AI-20	2
AI-23	526624001	Capacitor	1
AI-25	025040236	Washer for AI-24	1
AI-34	525551001	Pin Feed Stopper	1
AI-35	525743001	Screw for AI-34	1
AI-36	525674001	Connector	1
A	33680123-05	Tinnerman Clip (Logic board mtg. hardware)	4
B	34527207	Screw (Logic board mtg. hardware)	4
C	34000019	Fibre washer (Logic board mtg. hardware)	4
D	36615511-70	Spacer (used with any optional interface board) and standard board.	4
E	34527407	Screw (used with standard board and interface board.	4

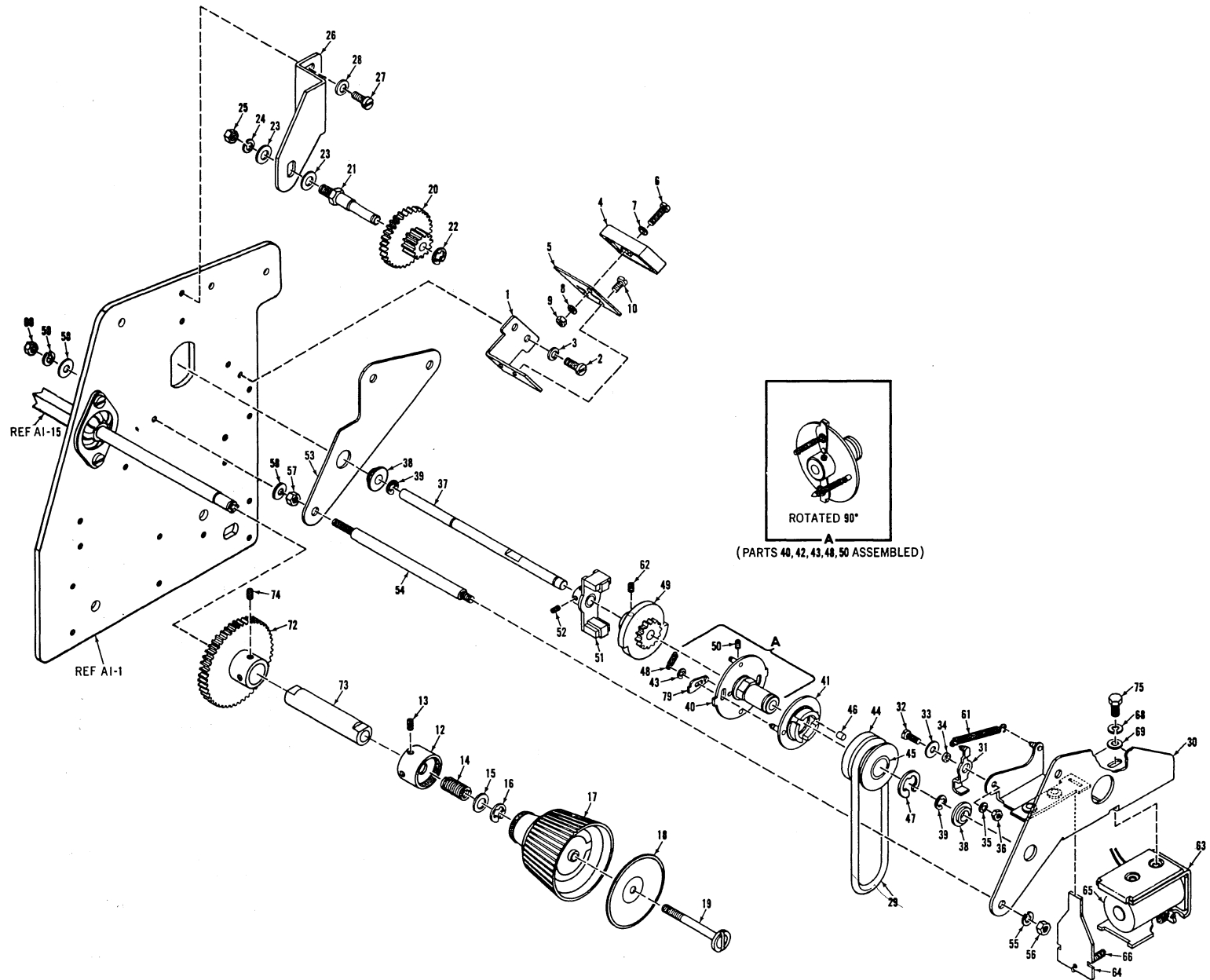

Figure 8-10. PAPER FEED - AJ

Figure AJ Paper Feed

8-26

Reference Number	Part Number	Part Name	Quantity	Reference Number	Part Number	Part Name	Quantity
AJ-1	526544001	Bracket Reed Switch, Line Counter	1	AJ-35	028030247	Spring washer for AJ-32	1
AJ-2	007400816	Screw for AJ-1	2	AJ-36	021300106	Nut for AJ-32	1
AJ-3	028040247	Spring washer for AJ-2	2	AJ-37	526672001	PF clutch shaft	1
AJ-4	525721001	Reed switch, line counter	1	AJ-38	525353001	Bearing for AJ-37	2
AJ-5	525725001	Adjusting holder for AJ-4	1	AJ-39	048040346	Snap ring for AJ-37	2
AJ-6	001301403	Screw for AJ-4	1	AJ-40	526607001	PF clutch inner cam	1
AJ-7	025030133	Washer for AJ-6	1	AJ-41	525333001	FF clutch releaser	1
AJ-8	028030247	Spring washer for AJ-6	1	AJ-43	048020346	Snap ring for AJ-42	2
AJ-9	021300106	Nut for AJ-6	1	AJ-44	526927001	PF clutch pulley	1
AJ-10	007300516	Screw for AJ-5	2	AJ-45	526686000	Bearing insert (press-fitted)	1
AJ-12	525769001	Paper Feed Knob Coupler	1	AJ-46	508532001	Roller	3
AJ-13	525748001	Screw for AJ-12	2	AJ-47	048080346	Snap ring for AJ-37	1
AJ-14	525768001	Spring for AJ-12	1	AJ-48	510062001	Spring for AJ-40	2
AJ-15	025060136	Washer for AJ-12	1	AJ-49	526685001	PF cam	1
AJ-16	048050346	Snap ring for AJ-12	1	AJ-50	525743001	Screw for AJ-49	2
AJ-17	526821001	Paper feed knob	1	AJ-51	526602001	One line counter (L)	1
AJ-18	526719001	Ornamental plate for AJ-17	1	AJ-52	525747001	Screw for AJ-51	2
AJ-19	526745001	Screw for AJ-17	1	AJ-53	526668001	PF chassis (L)	1
AJ-20	526675001	Paper feed idle gear	1	AJ-54	526666001	PF chassis shaft	3
AJ-21	526674001	Axle for AJ-20	1	AJ-55	028040247	Spring washer for AJ-54	3
AJ-22	048040346	Snap ring for AJ-21	1	AJ-56	021400106	Nut for AJ-54	3
AJ-23	025050236	Washer for AJ-21	2	AJ-57	021400106	Nut for AJ-54	3
AJ-24	028050247	Spring washer for AJ-21	1	AJ-58	025040236	Washer for AJ-54	6
AJ-25	021500106	Nut for AJ-21	1	AJ-59	028040247	Spring Washer for AJ-54	3
AJ-26	526673001	PF idle gear holder	1	AJ-60	021400106	Nut for AJ-54	3
AJ-27	007400816	Screw for AJ-26	2	AJ-61	511091001	Spring for AJ-31	1
AJ-28	025040236	Washer for AJ-27	2	AJ-62	525743001	Screw for AJ-49	2
AJ-29	526867000	O-ring	1	AJ-63	527856001	Clutch Magnet Core	1
AJ-30	526687001	PF chassis (R) (with riveted armature slide)	1	AJ-64	525351001	Armature	1
AJ-31	525753001	Back Stopper Pawl	1	AJ-65	527027001	Clutch Magnet Coil	1
AJ-32	007300803	Screw for AJ-31	1	AJ-66	527026001	Spring for AJ-64	1
AJ-33	503092001	Washer for AJ-32	1	AJ-68	028030247	Spring Washer for AJ-67	2
AJ-34	525756001	Collar for AJ-32	1	AJ-69	025030236	Washer for AJ-67	2
				AJ-72	527599001	PF Gear	1
				AJ-73	526964001	PF Coupling (Short)	1
				AJ-74	52743000	PF Screw for item 72	2

Figure AJ - Paper Feed (cont'd)

Reference Number	Part Number	Part Name	Quantity
AJ-70	527032001	Clutch Magnet Unit Note: This part is assembled with parts covering reference number AJ-63 through AJ-66.	1
AJ-71	526957001	Paper Feed Assembly Note: This part is assembled with parts covering reference number AJ-29 through AJ-41, AJ-43 through AJ-57, and AJ-61 through AJ-69, AJ-75, and AJ-79.	1
AJ-72	527599001	PF Gear	1
AJ-73	526964001	PF Coupling (Short)	1
AJ-74	52743000	PF Screw for Item AJ-73	1
AJ-75	527249001	Bolt for AJ-63	2
AJ-76	526993001	PF Gear Unit	1
AJ-77	526605001	PF Clutch Unit Note: This unit is assembled with parts covering from reference no's AJ-40 through AJ-48.	1
AJ-78	526699001	Line Counter, Reed Switch Unit Note: This unit is assembled with parts covering from reference no's AJ-4 to AJ-9.	1
AJ-79	526608021	Clutch Release Pawl	2

8-27/8-28

Rev. C

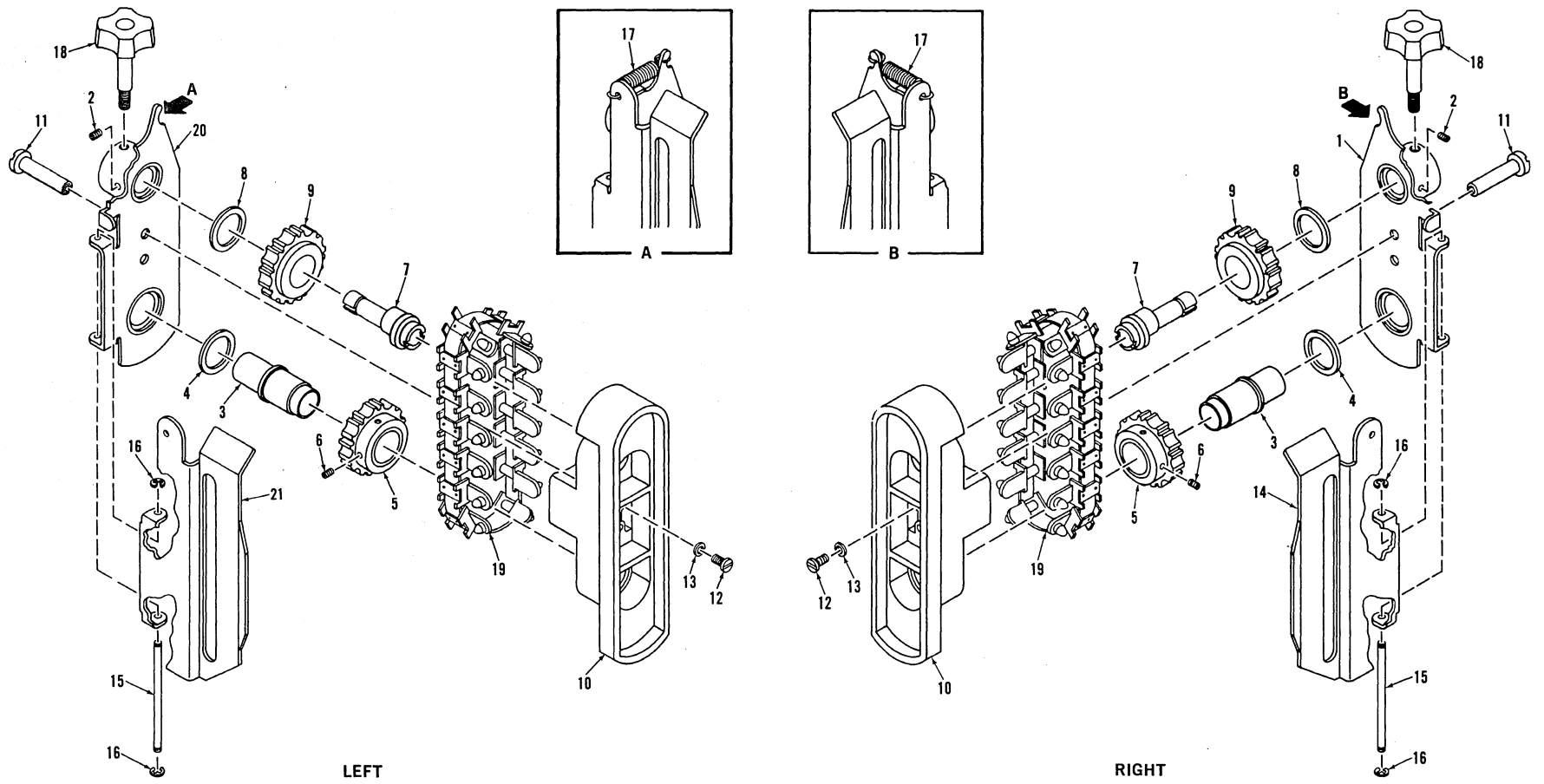

Figure 8-11. PIN FEED - AK

## Figure AK Pin Feed

Reference Number	Part Number	Part Name	Quantity
AK-1	525281001	PF holder (R)	1
AK-2	525747001	Screw for AK-1	2
AK-3	525287001	PF driving sleeve	2
AK-4	525288001	Washer for AK-3	2
AK-5	525289001	PF driving pulley	2
AK-6	525746001	Screw for AK-5	4
AK-7	525290001	PF stop sleeve	2
AK-8	525291001	Washer for AK-7	2
AK-9	525292001	PF idle pulley	2
AK-10	525294001	Paper guide (for belt)	2
AK-11	525295000	Screw (internal thread) for AK-10	4
AK-12	001300716	Screw for AK-11	4
AK-13	025030236	Washer for AK-12	4
AK-14	525296001	Paper guide plate (R)	1
AK-15	525297001	Shaft for AK-14	2
AK-16	048015346	Snap ring for AK-15	4
AK-17	525298001	Spring for AK-14	1
AK-18	525552001	Locking Knobs	2
AK-19	525300001	Timing belt unit	2
AK-20	525305001	PF holder (L)	1
AK-21	525309001	Paper guide plate (L)	1
AK-22	525298001	Spring for AK-21	1
AK-23	525280001	Pin feed unit (R)	1
		Note: This part is assembled with parts covering reference number AK-1 through AK-19	
AK-24	525304001	Pin feed unit (L)	1
		Note: This part is assembled with parts covering reference number AK-2 through AK-13, AK-15, AK-16 and AK-18 through AK-22.	



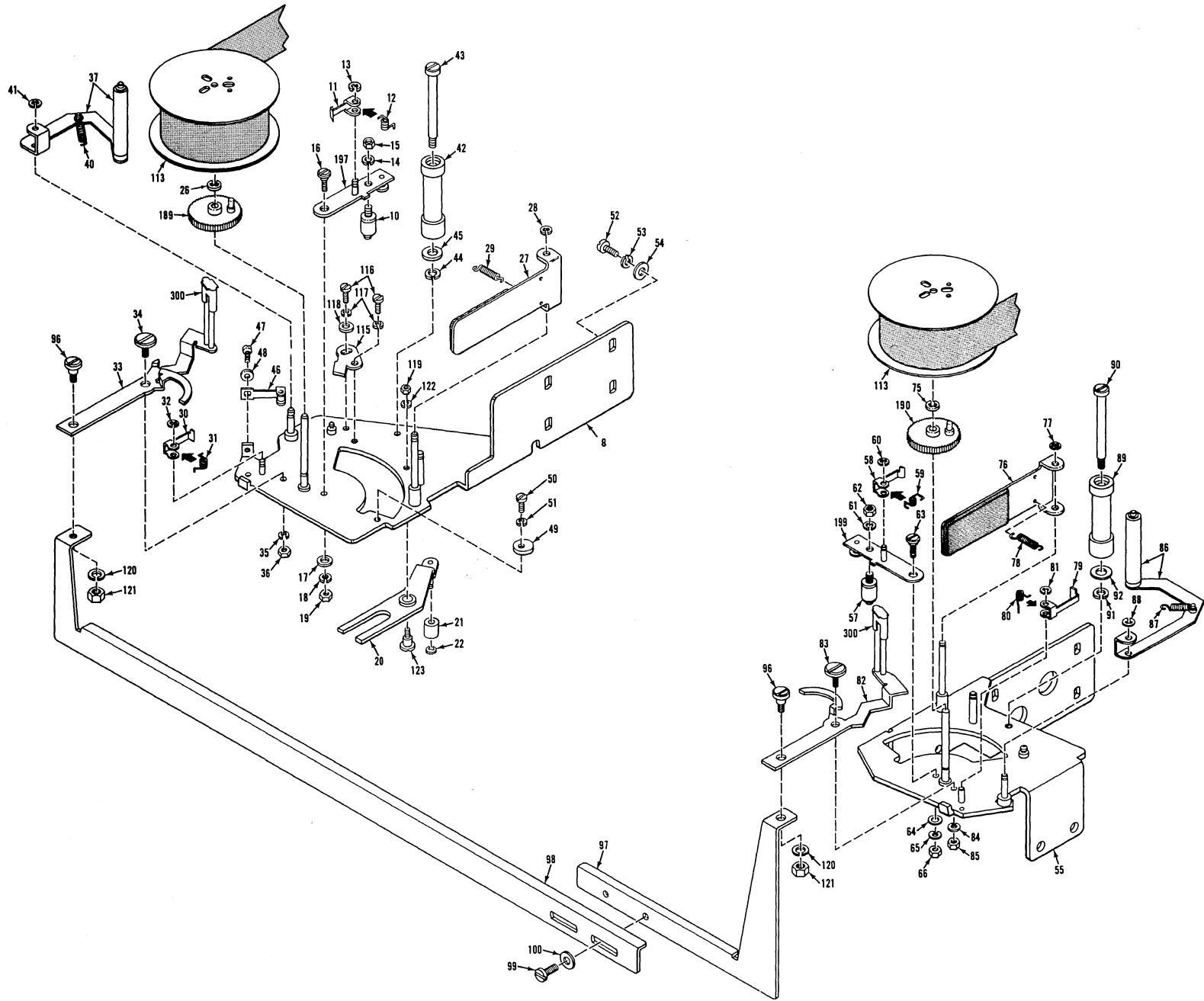

Figure 8-12. RIBBON FEED - AL (PART 1 OF 2)

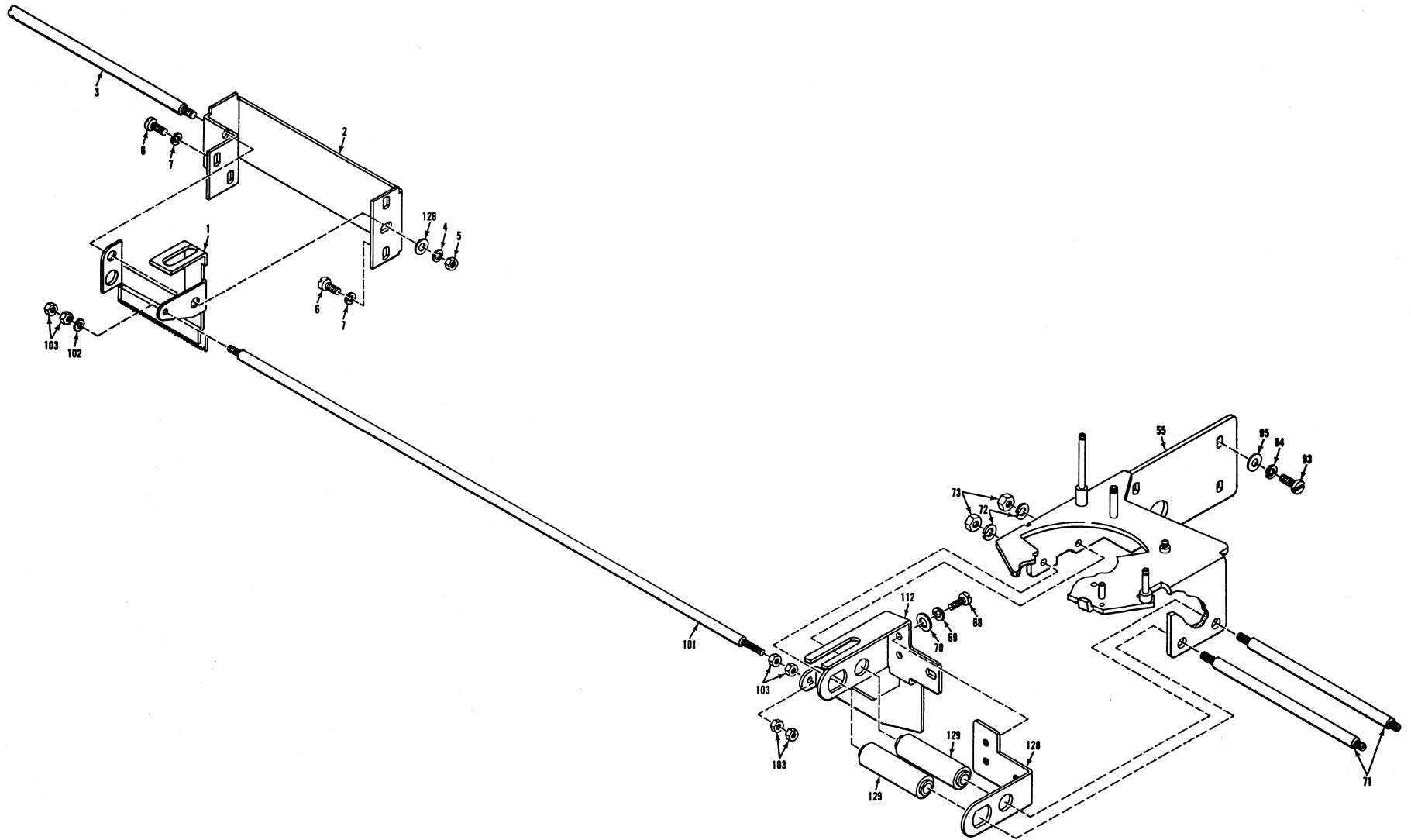

Figure 8-13. RIBBON FEED - AL (PART 2 OF 2)

Figure AL Ribbon Feed

8-33

Reference Number	Part Number	Part Name	Quantity	Reference Number	Part Number	Part Name	Quantity
AL-1	526928001	Ribbon feed rack	1	AL-40	526578001	Spring for AL-37	1
AL-2	526728001	RF rack guide plate	1	AL-41	048020346	Snap ring for AL-37	1
AL-3	526603001	Shaft for AL-1 (L)	1	AL-42	526580000	Guide roller	1
AL-4	028040247	Spring washer for AL-3	1	AL-43	526579001	Axle for AL-42	1
AL-5	021400106	Nut for AL-3	1	AL-44	028040247	Spring washer for AL-43	1
AL-6	007400816	Screw for AL-2	4	AL-45	025040336	Washer for AL-43	1
AL-7	028040247	Spring Washer for AL-6	4	AL-46	526581001	R releaser holder	1
AL-8	527742001	Ribbon holder plate (L)	1	AL-47	007300516	Screw for AL-46	1
AL-9	526598001	R pawl operator (L)	1	AL-48	025030236	Washer for AL-47	1
AL-10	526692001	R pawl operator roller	1	AL-49	526813001	R pawl operator (L) stopper	1
AL-11	526594001	R feed pawl (L)	1	AL-50	007300716	Screw for AL-49	1
AL-12	526595001	Spring for AL-11	1	AL-51	028030247	Spring Washer for AL-50	1
AL-13	048020346	Snap ring for AL-11	1	AL-52	007400816	Screw for AL-8	4
AL-14	028040247	Spring washer for AL-10	1	AL-53	028040247	Spring Washer for AL-52	4
AL-15	021400106	Nut for AL-10	1	AL-54	025040236	Washer for AL-52	4
AL-16	526570001	Screw for AL-9	1	AL-55	526695001	Ribbon Holder (R)	1
AL-17	526569001	Washer for AL-16	1	AL-56	526697001	R pawl operator (R)	1
AL-18	028030247	Spring washer for AL-16	1	AL-57	526692001	R pawl operator roller	1
AL-19	021300106	Nut for AL-16	1	AL-58	526567001	R feed pawl (R)	1
AL-20	527741001	R pawl operator link (L)	1	AL-59	526568001	Spring for AL-58	1
AL-21	526565001	Roller for AL-20	1	AL-60	048020346	Snap ring for AL-58	1
AL-22	048020346	Snap ring for AL-20	1	AL-61	028040247	Spring washer for AL-56	1
AL-26	048030346	Snap ring for AL-25	1	AL-62	021400106	Nut for AL-56	1
AL-27	526817001	Ribbon holder (L)	1	AL-63	526570001	Screw for AL-56	1
AL-28	048020346	Snap ring for AL-27	1	AL-64	526569001	Washer for AL-63	1
AL-29	511198001	Spring for AL-27	1	AL-65	028030247	Spring washer for AL-63	1
AL-30	526591001	Ribbon stop pawl (L)	1	AL-66	021300106	Nut for AL-63	1
AL-31	526592001	Spring for AL-30	1		526932001	R pawl operator link unit	1
AL-32	048020346	Snap ring for AL-30	1			Note: This is assembled with parts covering from reference number AL-68 to AL-70, AL-112, AL-128 and AL-129	
AL-33	526596001	Ribbon releaser (L)	1				
AL-34	526731001	Screw for AL-33	1	AL-68	007400816	Screw for AL-128	3
AL-35	028030247	Spring washer for AL-34	1	AL-69	028040247	Spring washer for AL-68	3
AL-36	021300106	Nut for AL-34	1	AL-70	025040236	Washer for AL-68	3
AL-37	526694001	R tension roller Unit (L)	1				

Figure AL - Ribbon Feed (con't)

Reference Number	Part Number	Part Name	Quantity				
AL-71	526585001	Shaft for AL-55	2	AL-116	007300616	Screw for AL-115	2
AL-72	028040247	Spring washer for AL-71	2	AL-117	028030247	Spring washer for AL-116	2
AL-73	021400106	Nut for AL-71	2	AL-118	025030236	Washer for AL-116	1
AL-75	048030346	Snap ring for AL-74	1	AL-119	021300106	Nut for AL-123	1
AL-76	526817001	Ribbon holder (R)	1	AL-120	028030247	Spring washer for AL-96	2
AL-77	048020346	Snap ring for AL-76	1	AL-121	021300106	Nut for AL-96	2
AL-78	511198001	Spring for AL-76	1	AL-122	028030247	Spring washer for AL-123	1
AL-79	526560001	Ribbon stop pawl (R)	1	AL-123	526831001	Screw for AL-20	1
AL-80	526561001	Spring for AI-79	1		526547001	Ribbon feed assembly (right)	1
AL-81	048020346	Snap ring for AL-79	1			Note: Assembled with parts covering reference number AL-55 through AL-73, AL-75 through AL-92, AL-112 and AL-190.	
AL-82	526571001	Ribbon releaser (R)	1		526587001	Ribbon feed assembly (left)	1
AL-83	526731001	Screw for AL-82	1			Note: Assembled with parts covering reference number AL-8 through AL-22, AL-26 through AL-51, AL-115 through AL-119, AL-122, AL-123 and AL-189.	
AL-84	028030247	Spring washer for AL-83	1				
AL-85	021300106	Nut for AL-83	1				
AL-86	526574001	R tension roller unit. (R)	1	AL-126	025040130	Washer for AL-3	1
AL-87	526578001	Spring for AL-86	1		526696001	R pawl operator unit (R)	1
AL-88	048020346	Snap ring for AL-86	1			Note: This unit is assembled with parts covering from AL-56 to AL-62.	
AL-89	526580000	R guide roller	1				
AL-90	526579001	Axle for AL-89	1	AL-128	526804001	R pawl operator link (R) plate	1
AL-91	028040247	Spring washer for AL-90	1	AL-129	526805001	Sleeve	2
AL-92	025040336	Washer for AL-90	1		526698001	R pawl operator unit (L)	1
AL-93	007400816	Screw for AL-55	4			Note: This unit is assembled with parts covering from AL-9 to AL-15.	
AL-94	028040247	Spring washer for AL-93	4				
AL-95	025040236	Washer for AL-93	4	AL	526599001	R pawl operator link unit (L)	1
AL-96	526929001	Screw for AL-33, 82	2			Note: This unit is assembled with parts covering from reference number AL-20 to AL-22.	
AL-97	526930001	R rod link (R)	1				
AL-98	526931001	R rod link (L)	1	AL	526694001	R Tension roller unit (L)	1
AL-99	007400816	Screw for AL-97, 98	2			Note: This unit is assembled with parts covering from reference no. AL-37 to AL-39.	
AL-100	025040236	Washer for AL-99	2				
AL-101	526914001	Ribbon feed bar	1	AL	526555001	Ribbon Feed Unit	1
AL-102	025030236	Washer for AL-101	2			Note: This unit is assembled with parts covering from reference number AL-1 to AL-5 and AL-126.	
AL-103	021309106	Nut for AL-101	6				
AL-112	526915-01	R pawl operator link (R)	1	AL-189	527774001	R Feed ratchet (L)	
AL-113	63002293	Ribbon with spool (twin-spool)	1	AL-190	527775001	R Feed ratchet (R)	
AL-115	526832001	R pawl operator (L) stopper	1	300	63002294-2001	Ribbon Guide Cap	2

8-35

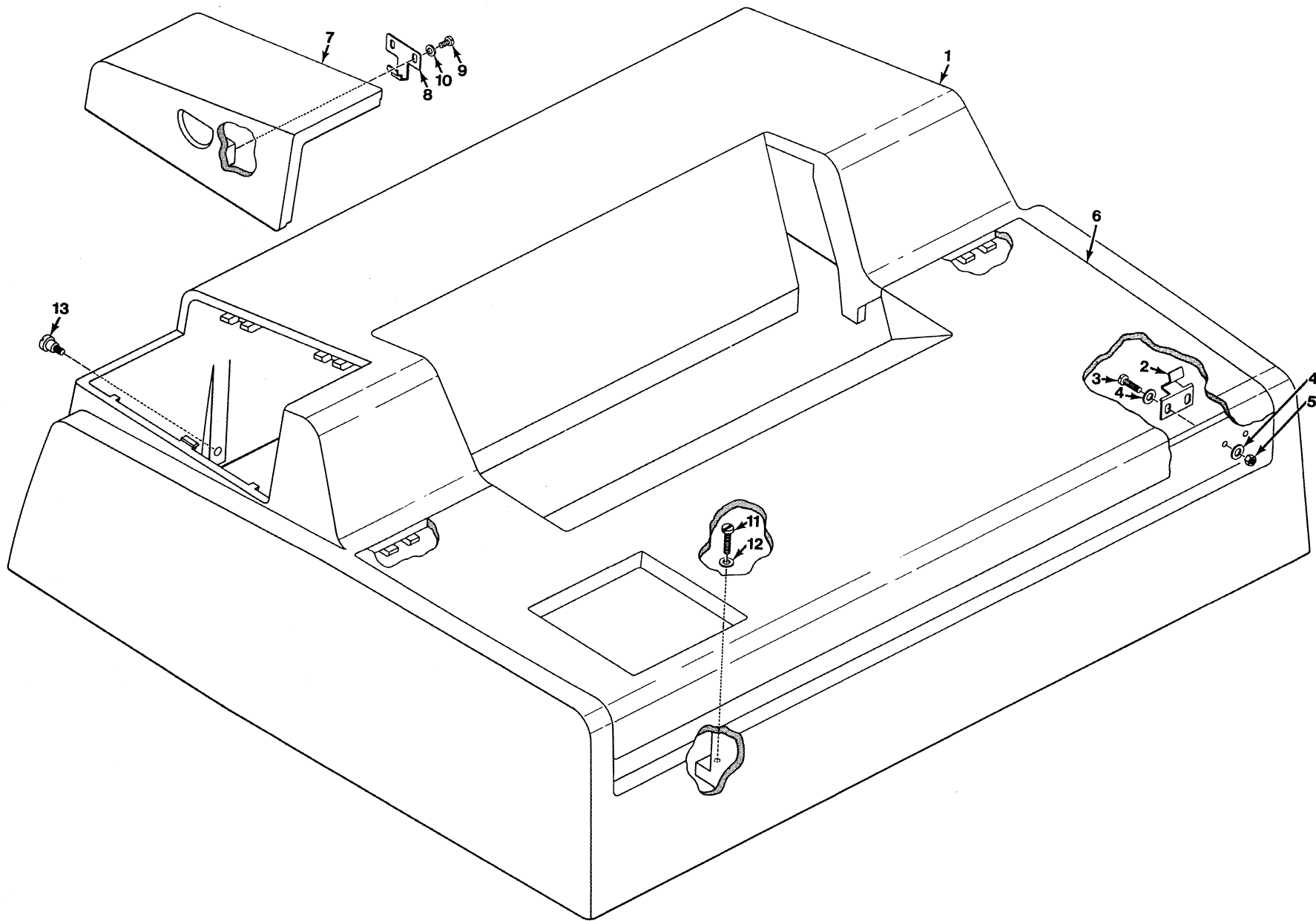

Figure 8-14. COVER - AM

Rev. B

Figure AM Cover

Reference Number	Part Number	Part Name	Quantity
AM-1	526736001	Cover	1
AM-2	526630001	Spring for AM-1	2
AM-3	007401416	Screw for AM-2	4
AM-4	025040236	Washer for AM-3	8
AM-5	021400106	Nut for AM-3	4
AM-6	526738001	Top cover	1
AM-7	526799001	Form feed cover	1
AM-8	526636001	Spring for AM-7	1
AM-9	007300516	Screw for AM-7	2
AM-10	025030236	Washer for AM-9	2
AM-11	007401416	Screw for AM-1	2
AM-12	025040236	Washer for AM-11	2
AM-13	526613001	Screw for AM-1	2

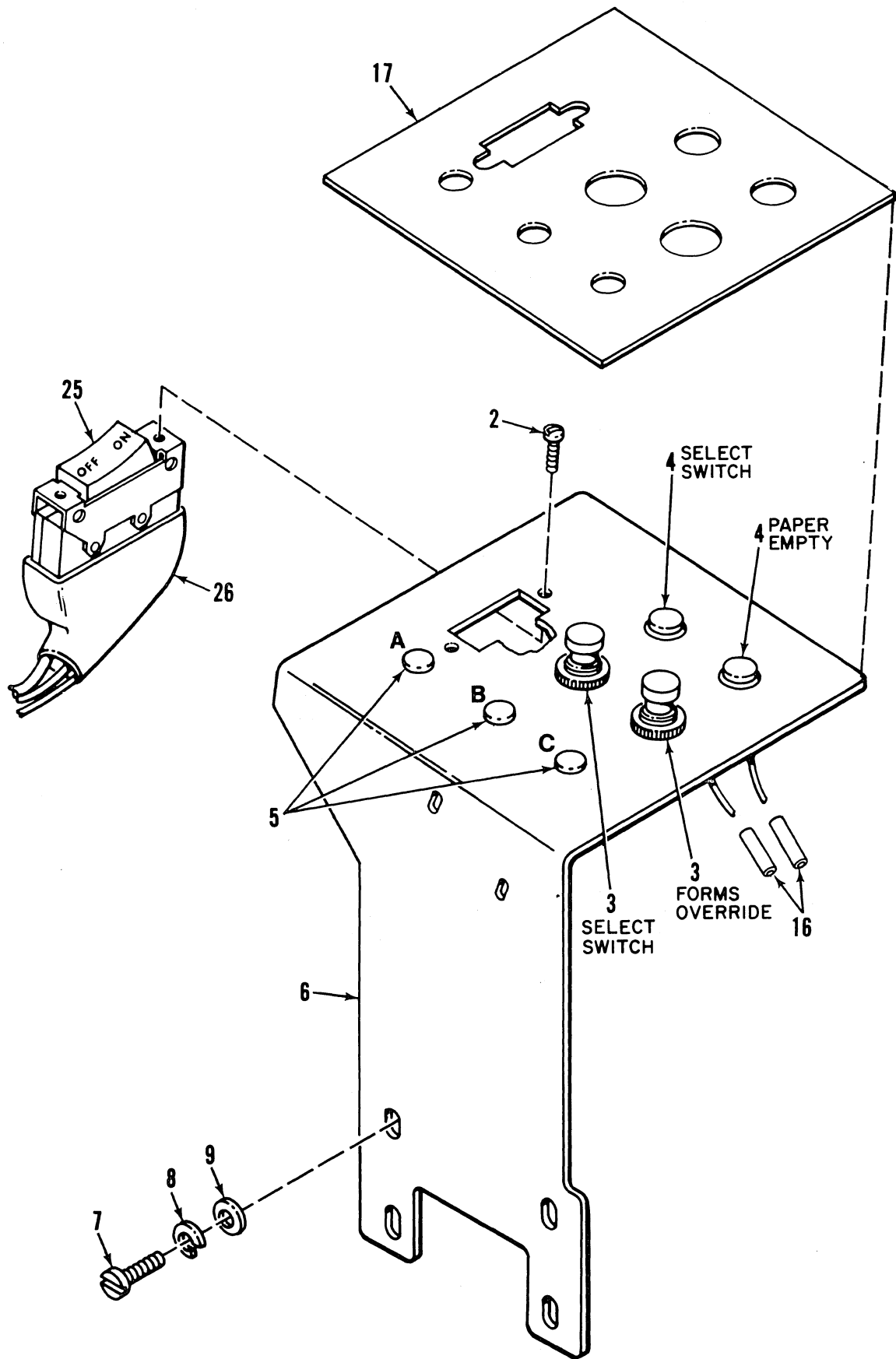
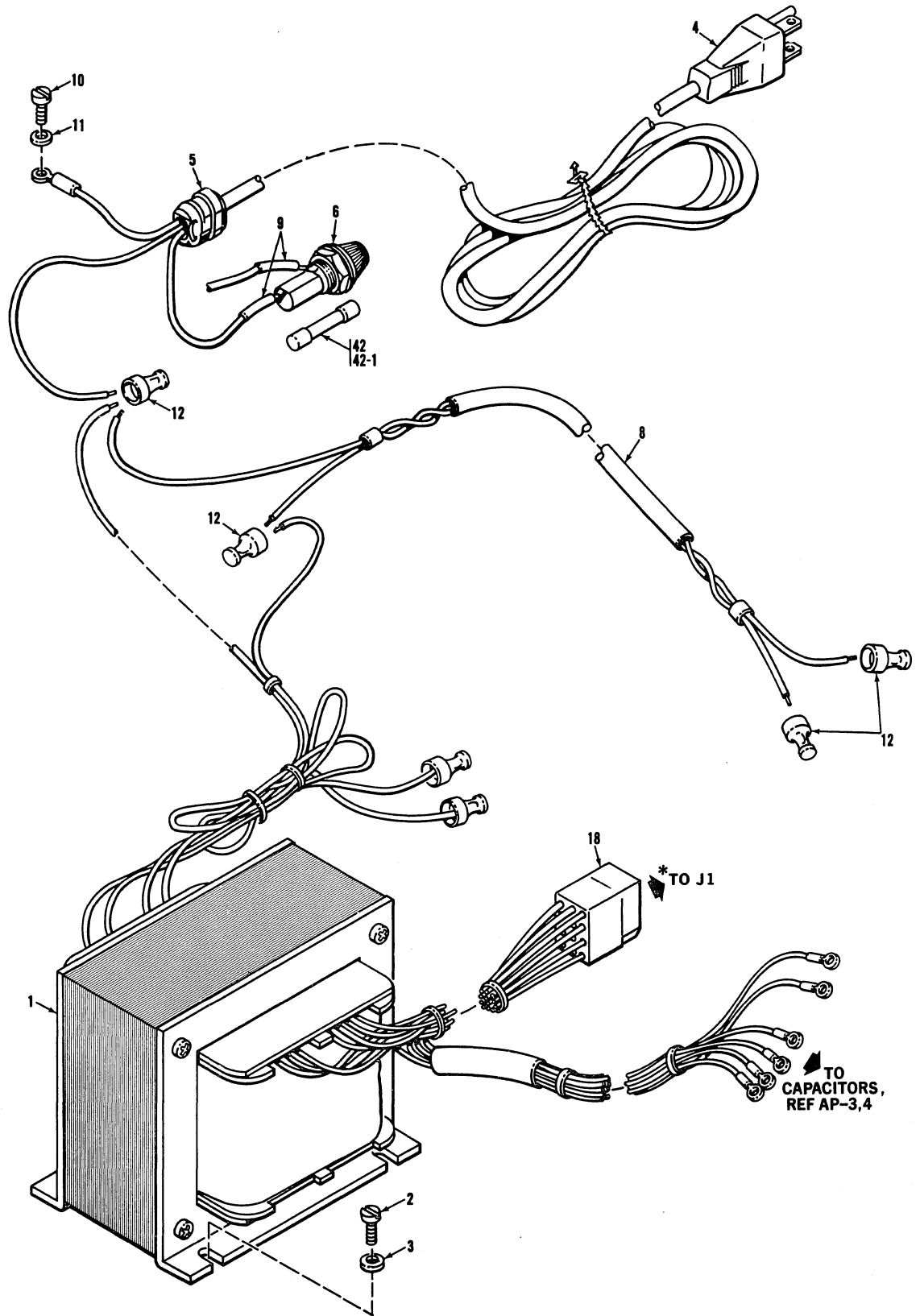

Figure 8-15. OPERATOR PANEL - AN

Figure AN - Operator Panel

Reference Number	Part Number	Part Name	Quantity
AN-2	526765001	Screw for AN-1	2
AN-3	526750001	Select Switch	2
AN-4	526752001	Pilot Lamp	2
AN-5	525864002	Button	3
5A	390925Q4-1001	Line Feed Switch (Option) (SPST) (Option)	1
5B	39092000-1001	Single/Double Line Feed Switch (Option) (SPDT)	1
5C	39092502-1001	Top of Form Switch (Option) (SPST)	1
AN-6	526661001	Operator Panel	1
AN-7	007400816	Screw for AN-6	4
AN-8	028040247	Spring Washer for AN-7	4
AN-9	025040236	Washer for AN-7	4
AN-16	526935001	Tube, Insulation	2
AN-17	63060183-3003	Control Panel (Blk. Bkgd.)	1
AN-25	529054001	Power Switch	1
AN-26	529050001	Cap, for AN-25	1





\*SECTION 7, 63060104, ITEM 79

Figure 8-16. ELECTRICAL COMPONENTS (PART 1 OF 3) - A0

Figure A0 Electrical Components (part 1 of 3)

Reference Number	Part Number	Part Name	Quantity
A0-1	526792001	Transformer unit - 110 volts (50 or 60 Hz)	1
A0-1-1	526866001	Transformer unit - 220 volts (50 or 60 Hz) (Option)	1
A0-2	007401016	Screw for A0-1	4
A0-3	025040136	Washer for A0-2	4
A0-4	526782001	Supply cord	1
A0-5	526772001	Nylon collar for A0-4	1
A0-6	526773001	Fuse holder	1
A0-8	526812001	Motor connector wire	1
A0-9	525675001	Insulating tube	2
A0-10	007400516	Screw for A0-5	1
A0-11	550719002	Washer for A0-10	1
A0-12	525674001	Cap, splice insulator, No. 3	5
A0-13	526902001	Arc - suppression unit	1
A0-14	007400716	Screw for A0-13	1
A0-15	025040136	Washer for A0-14	1
A0-16	526900001	Clamp, cable	1
A0-17	526903001	Wire (B)	1
A0-18	526785001	Connector	
		Molex 03-09-1121 (with mtg ears)	1
		Molex 03-09-1122 (without mtg ears)	1
A0-42	528352001	Fuse, 3 Amperes, 110 Volts	1
A0-42-1	528351001	Fuse, 2 Amperes, 220 Volts	1

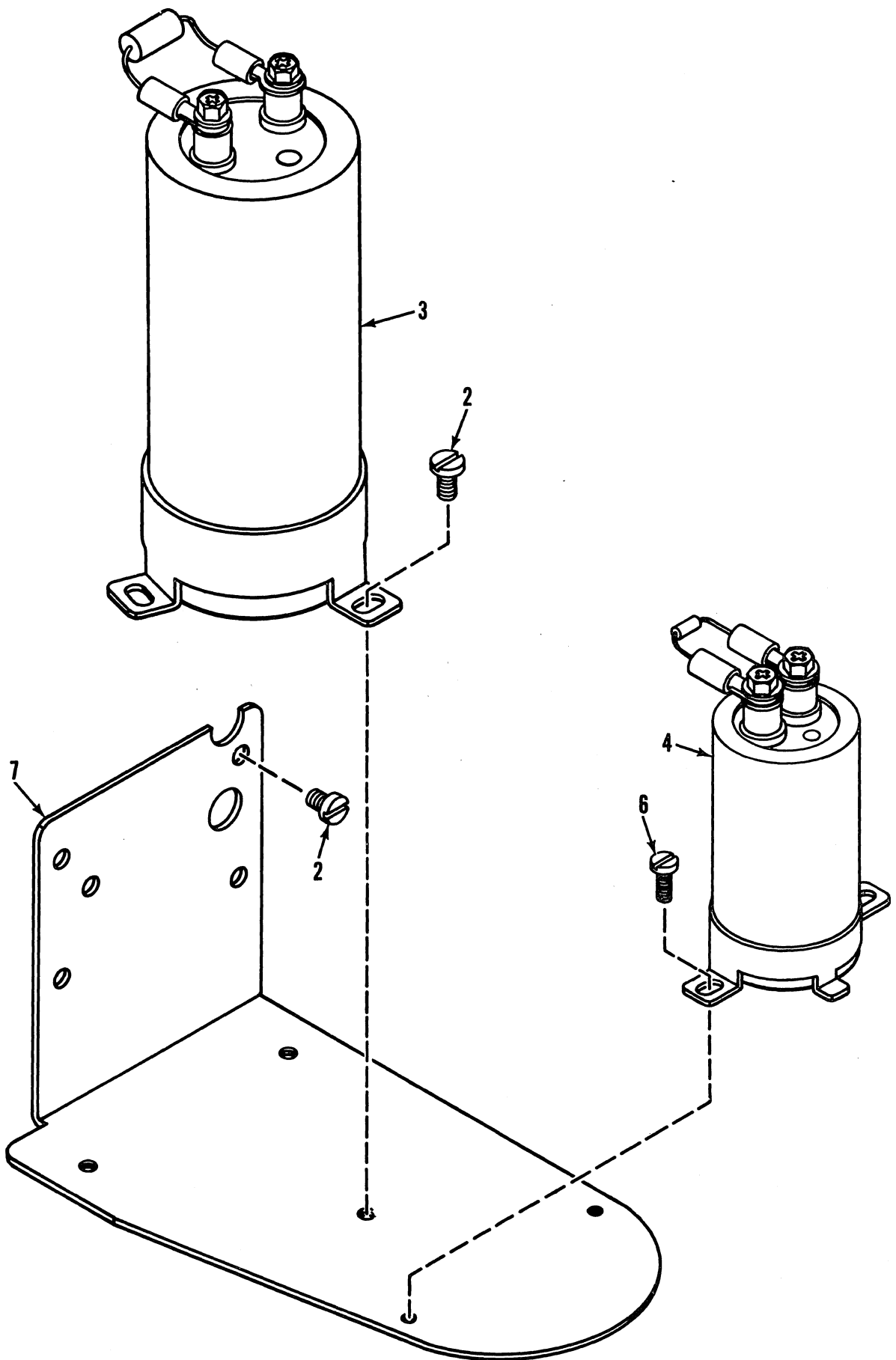

Figure 8-17. ELECTRICAL COMPONENTS (PART 2 OF 3) - AP

Figure AP Electrical Components (part 2 of 3)

Reference Number	Part Number	Part Name	Quantity
AP-2	007400416	Screw for AP-3, 4, 7	7
AP-3	526791001	Electrolytic Capacitor Ass'y (50V, 10,000 uf)	1
AP-4	526789001	Electrolytic Capacitor Ass'y (25V, 4700 uf)	1
AP-6	007300416	Screw for AP-4	2
AP-7	526948001	Bracket, Capacitor	1

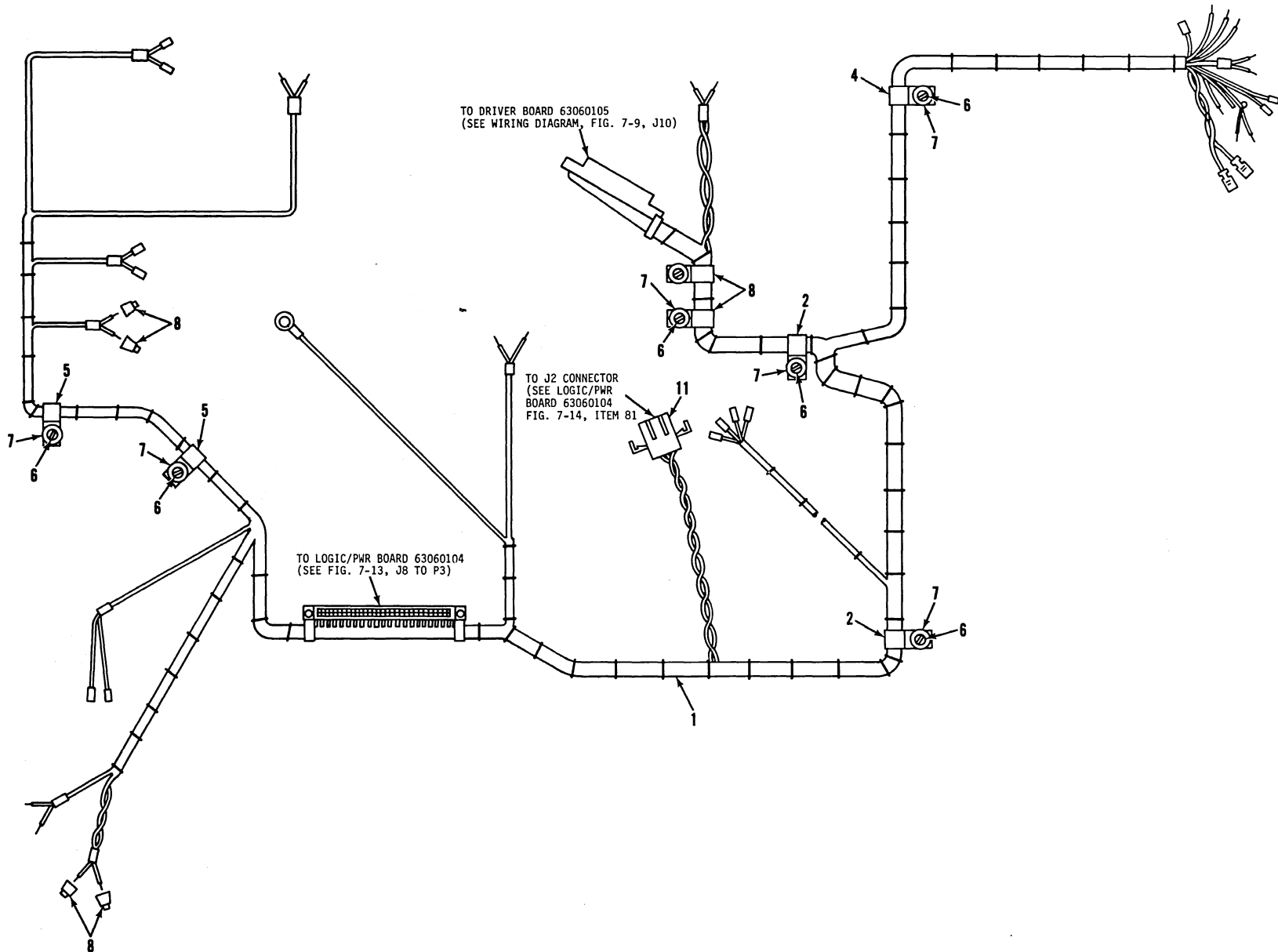

Figure 8-18. ELECTRICAL COMPONENTS (PART 3 OF 3) - AQ

Figure AQ Electrical Components (Part 3 of 3)

Reference Number	Part Number	Part Name	Quantity
AQ-1	526783001	Wire Harness Unit	1
AQ-2	525907000	Clamp, Cable, No. 9	2
AQ-4	525758000	Clamp, Cable, No. 5	1
AQ-5	120679001	Clamp, Cable, Type B	2
AQ-6	007400716	Screw for AQ-2, 4, 5, 9	7
AQ-7	025040136	Washer for AQ-6	7
AQ-8	207221600	Cap, Splicing	4
AQ-9	5255567000	Clamp, Cable, No. 8	2
AQ-10	525673001	Connector, 44 Pin (J8)	2
AQ-11	526793001	Connector	1
		Molex 03-09-2121	

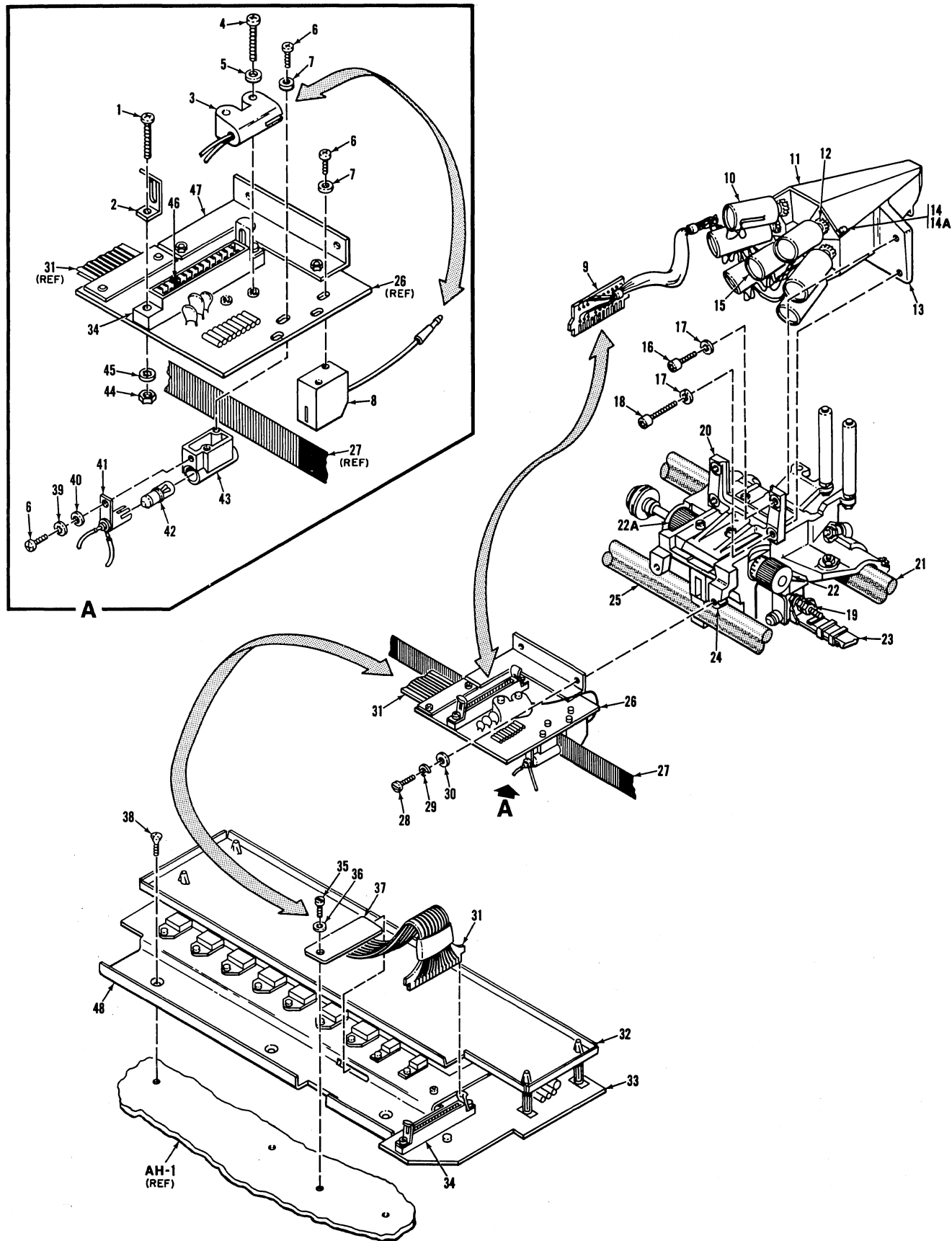

Figure 8-19. PRINT HEAD AND ASSOCIATED ASSEMBLIES

Figure 8-19. PRINT HEAD AND ASSOCIATED ASSEMBLIES, MODEL 306

Reference Number	Part Number	Part Name	Quantity	Reference Number	Part Number	Part Name	Quantity
1	34517167-2001	Screw, 4-50 x ½-in. lg, Pan/Phil Hd	2	26	63060107-4001	Video Amplifier Bd. Ass'y	1
2	63002300-2001	Clip, P.C. Board	2	27	63002440-2001	Flexible Mylar Timing Fence	1
3	63002257-5001	PhotoCell and Housing Ass'y	1	28	007400816-2001	Screw for Video Amp. Bracket (Ref: AA-96)	2
4	34517247-2001	Screw, 4-40 x ½-in. lg	2	29	028050247-2001	Washer, Lock, (Ref. AA-97)	2
5	34912007-2001	Washer, Flat, No. 4	4	30	025040236	Washer, Flat (Ref: AA-98)	1
6	34507087-2001	Screw , 2-56 x ½-in. lg, Pan/Phil Hd	5	31	63060146-4001	Ribbon Cable Ass'y (part of item 26)	1
7	34902007-2001	Washer, Flat, No. 2	5	32	63060114-5001	Shield Ass'y	1
8	63002248-2001	Fibre Optics Head	1	33	63060105-4005	P.C. Board, Power Driver	1
	63002437-4001	Print Head Ass'y, Die Cast, 7-Wire Ruby	1	34	31230011-1001	Connector, Edge, 20-pin	2
		Note: This unit is assembled with parts covering from reference no. 9 through 15.		35	007400815-2001	Screw for item 37	1
9	63001039-2002	Fingerboard, Solenoid, Head	1	36	025040235-2001	Washer, Flat for item 35	1
10	63002476-4002	Solenoid Ass'y	6	37	63060117-5001	Clamp, Ri-bon Cable, Tray	1
11	63002483-2001	Cover, Diecast Print Head	1	38	004400815-2001	Screw for item 33	3
12	63002122-2001	Nut, Locking, Solenoid	7	39	34805007-2001	Washer, Int. Lock, No. 2	1
13	63002462-4001	Head Subassembly	1	40	34902007-2001	Washer, Flat, No. 2	1
14	34507067-2001	Screw 2-56 x 3/16-in. lg, Pan/Phil Hd	2	41	63002598-2001	Lamp, Socket Assembly	1
14A	34805007-2001	Washer, Int, Lock, No. 2	2	42	37253790-1000	Lamp (GE-379)	1
15	63002476-4001	Solenoid Ass'y	1	43	63002259-2001	Housing, Lamp	1
16	34114161-2001	Screw, Hex, Socket Cap, 4-40 x ½-in. lg	2	44	34712007-2001	Nut, 4-40 for item 1	2
17	34815007-2001	Washer, Int. Tooth, Lock	4	45	34815007-2001	Washer, Int. Lock, No. 4 for item 1	2
18	34114201-2002	Screw, Hex, .Socket Cap, 4-40 x 5/8-in. lg	2	46	31240456-2002	Key (located between pin card D)	1
19	021500106-2001	Nut, Main Belt Adjust (Ref: BA-105)	2	47	63060115-2001	Mtg. Bracket, Video Amp. Bd. (Refer to Fig. 8-1, item 120)	1
20	526947000-2001	Head Bracket (Ref: AA-111)	1	48	63060113-2001	Heatsink/Mtg. Bracket	1
21	527506001-2001	Rear Guide Bar (Ref: AB-7)	1				
22	525544001-2001	Head Adjusting Knob (Ref: AA-58)	1				
22A	525025001-2001	Head Lock Knob (Ref: AA-59)	1				
23	527511001-5001	Drive Belt Unit (Ref: AE-9)	1				
24	526873001	Carriage (Ref: AA-51)	1				
25	527507001	Front Guide Bar (Ref: AB-12)	1				



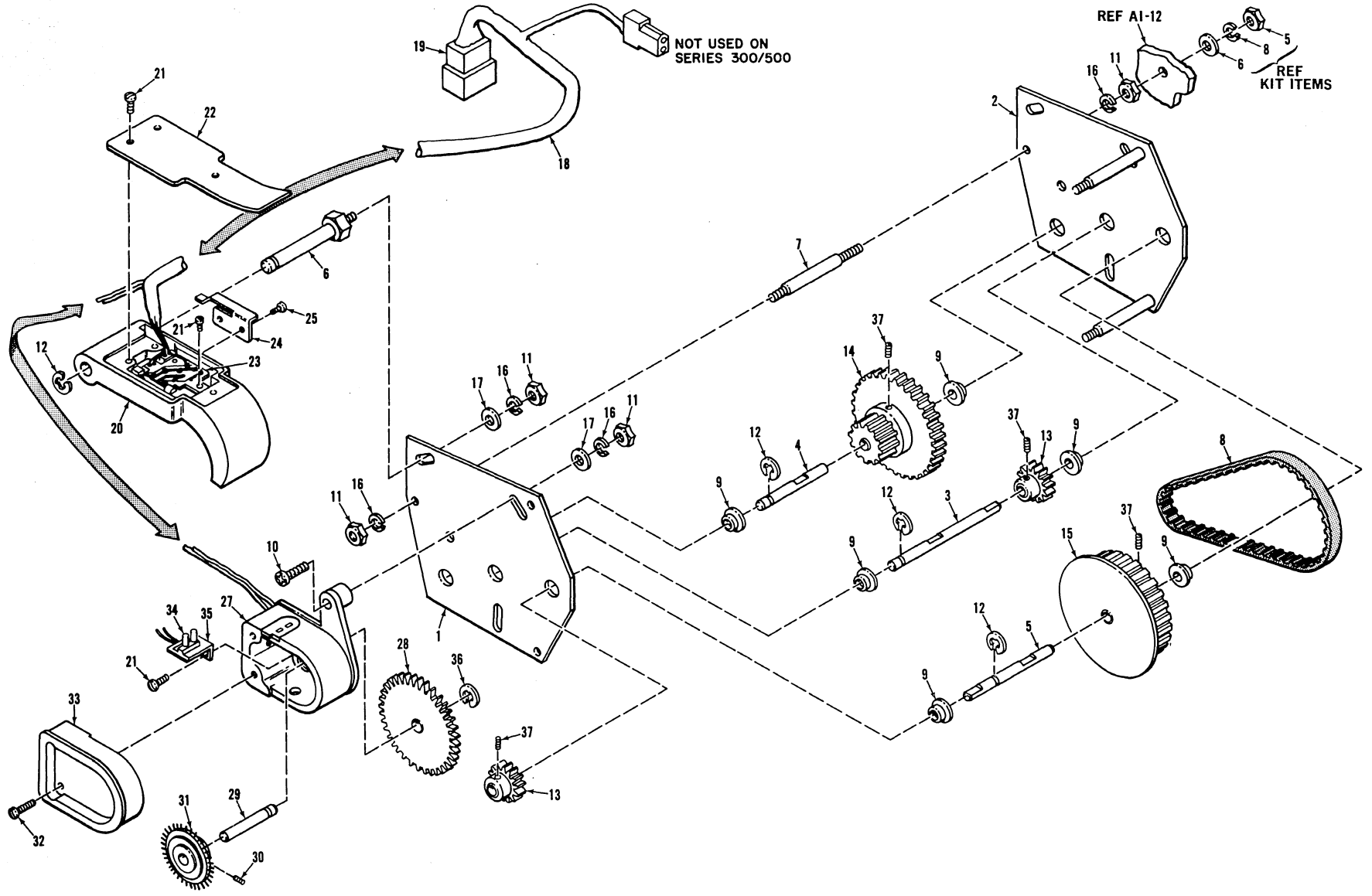

Figure 8-20. TAPE READER ASSEMBLY 68060125-5003 (OPTION)

LIST OF MATERIALS  
 SERIES 300 VERTICAL FORMAT UNIT (VFU) ASSEMBLY (OPTION)  
 LIGHT EMITTING DIODE (LED)  
 (6 LINES PER INCH/4 INCHES PER SEC. (IPS) (180° DRIVE)

Item	Part Number	Nomenclature	Quantity	Reference Number	Part Number	Nomenclature	Quantity
	63060173-6001	Kit, Vertical Format Unit (VFU) (Top Assembly), Complete	1	8	36400003-2001	Timing Belt	1
		Note: This kit is assembled with the following parts covering from item 1 through item 14.		9	36011005-2001	Bearing, Bronze	6
				10	34527207-2001	Screw 6/32 x 5/8-in. lg, Phil Hd	2
				11	34722007-2001	Nut, Hex, No. 6/32	9
1	63060125-5003	LED Tape Reader Ass'y, Model 306	1	12	33115144-2018	Retaining Ring	4
1A	63060125-5002	Tape Reader Ass'y, 306, 6 LPI, 2-Channel, (Alternate item, incandescent)	1	13	63060162-5001	Spur Gear Ass'y, 14T, 24P	2
2	39092504-1001	Switch Pushbutton, SPST	1	14	63060161-5001	Intermediate Gear Pulley Ass'y	1
3	63060174-3001	Decal, Top of Form	1	15	63060159-5001	Timing Pulley, 28 Teeth, Molded	1
4	39648505-0006-98	Wire, Type B, 22 AWG Wht/Gry (for Top of Form Switch)	AR	16	34828005-2001	Washer, No. 6, Split-Lock, SS	9
5	34722007-2001	Nut, Hex, No. 6/32	3	17	34922005-2001	Washer, No. 6, Flat, SS	3
6	34922007-2001	Washer, No. 6, Flat	3	18	63002671-4002	LED Tape Rdr. (VFU) Ass'y, AMER Drive	1
7	63060142-5001	Shaft Ass'y Drive	1			Note: This assembly is made up of parts covering from item 19 through 37	
8	34828005-2001	Washer, No. 6, Split Lock, SS	3	19	Molex, 1625-12R	Connector, Recept., 12-Pin (with ears)	1
9	63060252-6001	Kit, Shaft Coupling, 300/500	1	20	528539001-5001	LED Tape Reader Unit, Upper Ass'y	1
		Note: This unit is assembled with parts from item 10 through 11.		21	007200416-2001	Screw for items 21, 23, 36	5
10	33922061-2001	Set-Screw, 6-32 x 3/16-in. lg	4	22	525388001-2001	Lid for item 20	1
11	63060144-2002	Coupling, Shaft	2	23	529386001-4001	PC Board for Light Emitting Diode (LED)	1
12	34855005-2001	Washer, 1/4, Int. Tooth, SS	1	24	525377001-2001	Plate, Spring for item 20	1
13	31240020-2010	Pin Terminal, Female	4	25	007300416-2001	Screw for item 24	2
14	31340064-1002	Conn. Recept., 12 POS. (with ears)	1	26	63002674-5001	LED Tape Reader Unit, Lower Ass'y (Modified with American Drive Gear, item 28)	1
		The following assembly breakdown represents those parts contained in item 1 of the VFU kit and are keyed by number into Figure 8-20.		27	528532001-5001	LED Tape Reader, Lower	1
1	63060125-5003	LED Tape Reader Ass'y	1	28	63060134-2001	Spur Gear, 36 Teeth, 24P (American Drive)	1
		Note: This unit is assembled with parts and subassemblies item 2 through 25		29	39695231-2001	Cable Tie, 3-5/8-in. Lg	2
2	63060126-2001	Plate Mounting, Tape Reader	2	30	525746001-2001	Set-screw for item 31	2
3	63060127-2001	Shaft, Driver	1	31	525363001-2001	Sprocket for Tape	1
4	63060128-2001	Shaft, Pulley, Idler	1	32	007301216-2001	Screw for item 33	2
5	63060129-2001	Shaft, Pulley	1	33	525374001-2001	Cover for item 37	1
6	63060131-2001	Shaft, Pivot, Tape Reader Cover	1	34	528475000-1001	Light Emitting Diode (LED)	2
7	63060132-2001	Spacer Rod	3	35	528535001-2001	Bracket, LED PC Board	1
				36	048030346-2001	Snap Ring for item 28	1
				37	33912045-2001	Set-Screw for item 13, 14, 15	3

8-49

Rev. E

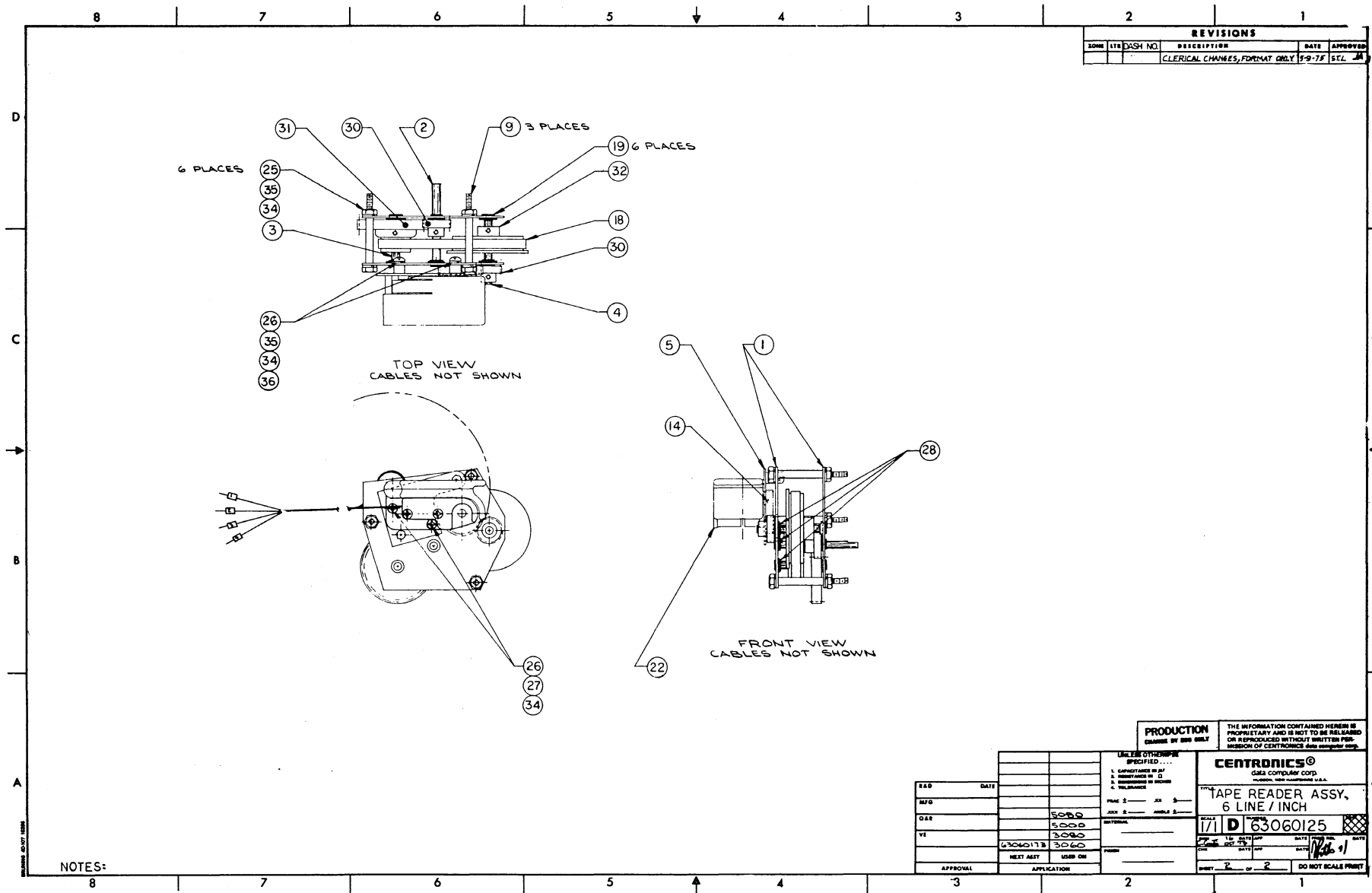

Figure 8-20A. TAPE READER ASSEMBLY 68060125-5002, (OPTION) (ALTERNATE)

TAPE READER ASSEMBLY (OPTION)  
PART 2, ALTERNATE

LIST OF MATERIALS  
VERTICAL FORMAT UNIT ASSEMBLY (OPTION), INCANDESCENT,  
(6 LINES PER INCH/4 INCHES PER SEC. (IPS) (180° DRIVE), ALTERNATE ITEM

<u>Item</u>	<u>Part Number</u>	<u>Nomenclature</u>	<u>Quantity</u>
	63060125-5002	Tape Reader Ass'y	1
		Note: This unit is assembled with parts from item 1 through 36.	
1	63060126-2001	Plate Mounting, Tape Reader 500	2
2	63060127-2001	Shaft Driver, 500	1
3	63060128-2001	Shaft Pulley, Idler	1
4	63060129-2001	Shaft Pulley	1
5	65008518-5001	Adapter Plate Ass'y	1
9	63060132-2001	Spacer Rod	3
14	65008508-5001	Spur Gear Ass'y, 24T Molded	1
18	36400003-2001	Timing Belt	1
19	36011005-2001	Bearing Bronze	6
22	65008500-4002	Tape Rdr. Ass'y, 2-Channel, 38T Dr.	1
25	34722007-2001	Nut, Hex No. 6/32	6
26	34527107-2001	Screw, 6/32 x .31 lg, Phil	4
27	34825007-2001	Washer, No. 6, Int. Tooth Lock	2
28	33115144-2018	Retaining Ring	3
30	63060162-5001	Spur Gear Ass'y, 14T 24P	2
31	63060161-5001	Intermediate Gear Pulley Ass'y	1
32	63060159-5001	Timing Pulley, 28 Teeth, Molded	1
34	30000000-0001	Insulating Varnish	AR
35	34828005-2001	Washer, No. 6, Split Lock, SS	8
36	34922005-2001	Washer, No. 6, Flat, SS	2

## APPENDIX A SIGNAL GLOSSARY

This signal listing is keyed directly to the 306 printer schematic drawings. All signal mnemonics contained on those drawings are listed alphabetically with their source and destinations.

The following notation is used to identify the source and destination locations: 23-1/38-1 signifies element ME23, pin 1 located on schematic 63060138, sheet 1.

SIGNAL NAME	DESCRIPTION	SOURCE	DESTINATION
ACK	Acknowledge - A 2.5-5.0 usec pulse used to indicate completion of the input of a character or end of a functional operation.	25-13/38-2	P4-Z/38-1
BELL	A 1 to 2-second pulse used to produce an audible tone in the optional speaker located at the front of the printer.	25-39/38-2	R27/38-1
<u>BUSY</u>	Status signal indicating to the input device that the printer is not ready to receive data.	25-11/38-2	20-1/38-1
CG1-CG7	Seven signal LINES from the character generators to the driver board, which fire print wires 1-7.	ME1 & ME7/38-4	P10-2, 3, 4, 6, 7, 8, 9/38-1
CHADD7	Character address line 7.	22-2/38-3	4-16/38-4
<u>CIP</u>	Carriage in Print - Signal used to drive the print head forward.	26-11/38-3	2-9/06-2
<u>CIPM</u>	Carriage in Print - Signal to Motor Control Unit, is a command to drive print head in forward direction.	21-8/38-1	26-2/38-3
<u>CIPX</u>	Carriage in Print - Signal from LSI chip #2, command to turn on forward clutch.	16-30/38-2	21-11/38-1
CLKTB1	Clock pulse used to clock input data into memory register. Used for loading data only.	25-14/38-2	22-9/38-3
CLKTB2	Clock pulse used to shift memory. Not used when loading data.	16-36/38-2	22-3/38-3
<u>CSBSY</u>	Cause Busy - Command from LSI chip 2 to LSI chip 1 to cause a busy condition, when dummy character is detected at memory output.	16-35/38-2	25-10/38-2
CSLF	Cause Line Feed - Line feed command from LSI chip #1.	25-6/38-2	32-3/38-1
DATA 1 - DATA 8	The 8 input data lines coming from the input device to the printer.	P4-V, T, U, X, S, M, W, N/38-1	

SIGNAL NAME	DESCRIPTION	SOURCE	DESTINATION
<u>DATA STROBE</u>	A 1.0 usec (min.) pulsed used to clock data from the input device to the printer logic.	P4-Y/38-1	
<u>DCPRM</u>	Decoded Prime - Prime command from LSI chip #1 to LSI chip #2 causes prime condition.	25-8/38-2	16-31/38-2
<u>DCWI-DCW5</u>	Five full step data write pulses from LSI chip #2 to ROM character generator.	ME16/38-2	ME4/38-4
<u>DCW01-DCW04</u>	Four half step data write lines to half-step ROM for 9 x 7 dot matrix.	ME16/38-2	ME10/38-4
DLF	Double Line Feed - Operator panel, double line feed switch option.	P3-20/38-1	E4/38-1
DLYLF	Delay Line Feed - A 90 ms pulse following any paper movement command. Allows settle-out time for the form feed mechanical parts.	32-5/38-1	25-37/38-2
DLYSTB	Delay Strobe - A 500 us pulse used to generate data write signals in LSI chip #2 for the half step character generators.	28-5/38-1	16-22/38-2
<u>DSI-DS8</u>	Buffered input data 1 to 8.	ME24 & ME29/38-1	ME19 & ME18/38-3
<u>DSCR</u>	Decoded Carriage Return - Command from LSI chip #1 to LSI #2 to shift data to memory output and backfill shift register with zeroes.	25-12/38-2	16-33/38-2
DSTA	Data Strobe A signal used to inform LSI chip #1 that input data lines should be strobed into memory.	29-10/38-1	25-20/38-2
<u>EPOSW</u>	End of Print Switch - Terminates a full line of print, 80 characters.	P3-2/38-2	16-19/38-2
FAULT	Printer fault signal to input connector.	25-9/38-2	P4-L/38-1
FFH	Form Feed Hole - Vertical Format Unit option, Channel 1.	P3-V/38-2	25-29/38-2

SIGNAL NAME	DESCRIPTION	SOURCE	DESTINATION
INPUT PRIME	A level from the input connector causing the printer electronics to be printed.	P3-2/38-2	16-10/38-2
GDSTB	Gated Strobe - Gates strobe with ACK which prevents CLKTB1 until the rising edge of ACK and prevent over-running the buffer.	25-17/38-2	E8/38-2
$\overline{\text{LD}}$	Light Detect - Status signal to input connector, indicating the video circuit is not functioning.	16-17/38-2	P4-A/38-1
LF	Line Feed - 15 ms signal generates PMSOL during line feed.	32-13/38-1	25-30/38-2
LFOC	Low frequency oscillator (option), allows 3-12 second paper movement time out.	C8/38-2	25-37/38-2
LINE COUNT PULSE & RETURN	Level from input connector, switched on and off by interval line count switch.	LF Count SW	
MOTOR CONTROL	Signal to motor control solenoid which turns on AC motor. (Option)	26-8/38-3	P3-P/38-2
OSC	Oscillator - 100KHz to 200 KHz clock provides timing for printer operations.	16-25/38-2	25-4/38-2
PE	Paper Empty signal indicating a paper empty condition.	20-11/38-1	25-34/38-2
$\overline{\text{PMSOL}}$	Paper Movement solenoid - Used to activate line feed solenoid during a line feed, form feed or vertical tab operation.	25-7/38-2	2-05/38-1
$\overline{\text{PMSOLD}}$	PMSOL Driver command to power driver.	21-6/38-1	2-11/06-2
PRIME	Prime signal, 100-400 usec pulse from LSI chip #1 used to reset printer logic.	16-37/38-2	25-38/38-2
$\overline{\text{PWR PRM}}$	Power Prime - Automatic prime generated by turning on power to the printer.		25-5 & 16-32/38-2
$\overline{\text{REMLF}}$	Remote Line Feed signal. Operator panel, LINE FEED switch option.	P3-2/38-2	25-33/38-2

SIGNAL NAME	DESCRIPTION	SOURCE	DESTINATION
ROME2	Signal which enables half-step ROM character generators.	16-24/38-2	17-9/38-4
ROMTB8	Enable signal used to select optional character sets by use of TB8.	21-12/38-3	17-13/38-4
$\overline{\text{RTPSW}}$	Ready to Print switch, informs LSI chip #2 that carriage is at left position.	P3-4/38-2	16-28/38-2
SELECT LAMP	Operator panel, SELECT indicator.		
SEL5W	Operator panel, SELECT switch.	P3-W/38-2	25-3/38-2
SLCT'	Select	25-40/38-2	22-5/38-1
$\overline{\text{SLCT}}$	Select status signal to input connector.	22-6/38-1	16-40/38-2
SPEAKER	Speaker option		
SRCL	Shift Register Clear - Signal from LSI chip 2 used to clear shift registers.	16-38/38-2	18-2 & 19-2/38-3
$\overline{\text{STROBE}}$	Strobe - A 500 usec pulse used to generate character address signals to the ROM during character printing.	23-1/38-1	E37/38-4
$\overline{\text{TBI-TB7}}$	Shift register outputs 1-7.	ME18, 19/38-3	ME4/38-4
TB8	Shift register output 8.	22-12/38-3	22-11/38-3
$\overline{\text{TB8}}$	Shift register output 8 used to select additional ROM or individual expanded characters.	22-10/38-3	E-33/38-3 16-34/38-2 E-17/38-2
TB8'	Same as TB8	18-4/38-3	
TOFSW	TOP OF FORM switch. Operator panel option.	P3-1/38-2	25-32/38-2
$\overline{\text{UPSC}}$	Expanded Character Mode - Command from LSI chip 1 to chip 2 to print elongated characters.	25-15/38-2	E20-38-2
VIDEO AMP	Video Amplifier Output - 1.4 ms square wave used to trigger STROBE one shot.	P3-9/38-1	23-5/38-1
VTH	Vertical Tab Hole - Vertical Format Unit option.	P3-4/38-2	25-28/38-2

APPENDIX B  
PARALLEL INTERFACE SPECIFICATION  
FOR CENTRONICS PRINTERS

B.1 INTERFACE TIMING

In general, the data transfer sequence consists of the input device placing the appropriate code on the data lines to the printer and then generating a data strobe pulse. The printer, after a slight delay, responds with an acknowledge pulse, or if the received data causes a busy condition, the printer first activates the busy line for the duration of the busy condition and then responds with an acknowledge pulse.

As a standard feature in all printers except the 101, data strobe is not recognized until the last character has been acknowledged (gated data strobe). As an option, however, data strobe can be recognized at any time.

Normal Data Input - No Busy

The diagram in Figure B-1 shows the timing involved in transferring data which does not cause a busy condition.

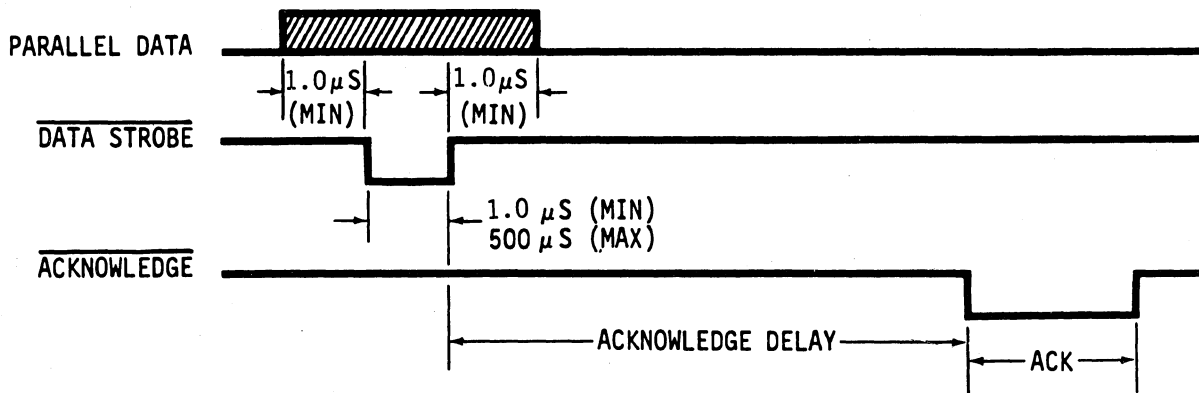

	101/101A/101S	101AL	102A	102AL	301	306	500	501
ACK DELAY	7 usec	2.5-10 usec	7 usec	2.5-10 usec	2.5-10 usec	2.5-10 usec	2.5-10 usec	2.5-10 usec
ACK	4 usec	2.5-5.0 usec	4 usec	2.5-5.0 usec	2.5-5.0 usec	2.5-5.0 usec	2.5-5.0 usec	2.5-5.0 usec

Figure B-1. NORMAL DATA INPUT  
B-1

## Data Input Causing Busy

The diagram in Figure B-2 shows the interface timing involved in transferring any data which causes a busy condition in the printer.

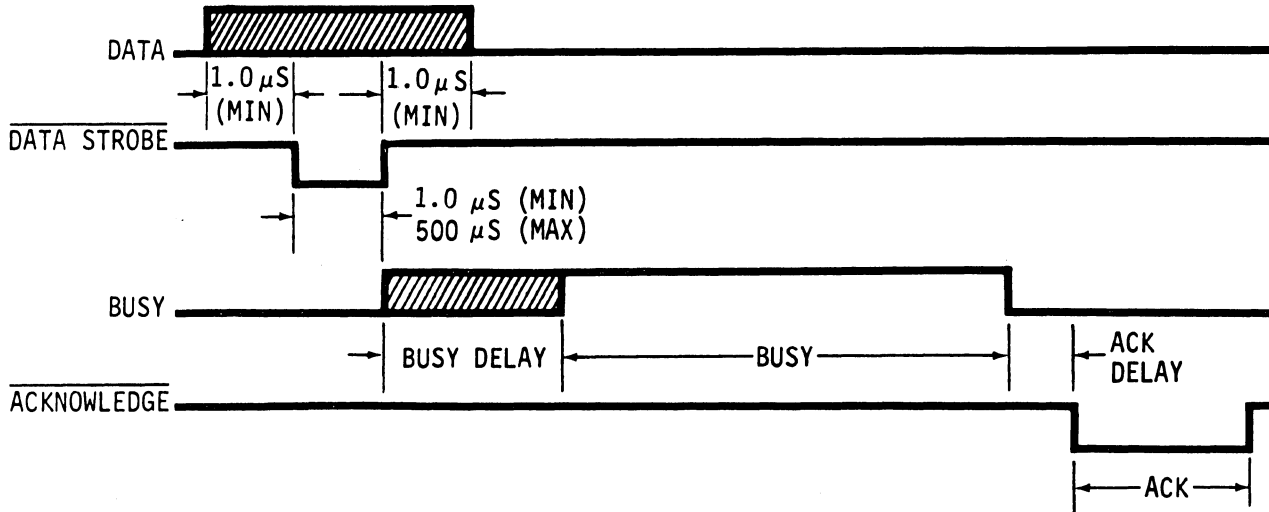

	101/101A/101S*	101AL	102A	102AL	301	306	500	501
BUSY DELAY	0	0-1.5 usec	0	0-1.5 usec	0-1.5 usec	0-1.5 usec	0-1.5 usec	0-1.5 usec
ACK DELAY	0	0-10.0 usec	0	0-10.0 usec	0-10.0 usec	0-10.0 usec	0-10.0 usec	0-10.0 usec
ACK	4 usec	2.5-5.0 usec	4 usec	2.5-5.0 usec	2.5-5.0 usec	2.5-5.0 usec	2.5-5.0 usec	2.5-5.0 usec
BUSY								
Line Feed	75-105 msec	75-105 msec	75-105 msec	16 msec (single LF) 75-105 msec (multiple LF)	70-100 msec	75-105 msec	75-105 msec	70-100 msec
Vertical Tab (1-inch)	300-310 msec	300-310 msec	300-310 msec	300-310 msec	160-200 msec	300-310 msec	300-310 msec	160-200 msec
Form Feed (11-inches)	3-3.5 sec	3-3.5 sec	3-3.5 sec	3-3.5 sec	1.5-2.0 sec	3-3.5 sec	3-3.5 sec	1.5-2.0 sec
Delete	3 msec	100-400 usec	3 msec	100-400 usec	100-400 usec	100-400 usec	100-400 usec	100-400 usec
Bell	2 sec	0	2 sec	0	0	0	0	0
Select	3 msec	100-400 usec**	3 msec	100-400 usec**	100-400 usec**	100-400 usec**	100-400 usec**	100-400 usec**
Deselect	Until printer is selected	Until printer is selected	Until printer is selected	Until printer is selected	Until printer is selected	Until printer is selected	Until printer is selected	Until printer is selected
Print Command	6 msec/char plus 75-105 msec LF	6 msec/char plus 75-105 msec LF	470-500 msec (total)	410-415 msec (total)	6 msec/char plus 70-100 msec LF	8.4 msec/char plus 75-105 msec LF	8.4 msec/char plus 75-105 msec LF	6 msec/char plus 70-100 msec LF
(Return time-no busy)	(240 msec max)	(240 msec max)	(0)	(0)	(270 msec max)	(270 msec max)	(400 msec max)	(400 msec max)

\*Vertical Tab and Form Feed durations for the 101S apply to 6 line/inch operation.

\*\*No busy if inhibit prime on select option is used.

Figure B-2. BUSY CONDITION TIMING



## B2. PARALLEL INTERFACE SIGNALS

All standard Centronics printers are supplied with an Amphenol #57-40360, 36-pin interface connector (Centronics #31310019). The pin assignments, name, source and description for each interface signal are listed below.

<u>Parallel Interface Connector</u>	<u>Signal Name</u>	<u>Source</u>	<u>Description</u>
Pin 1, 19*	DATA STROBE	Input Device	A 1.0 usec pulse (min.) used to clock data from the processor to the printer logic.
2, 20	DATA 1	Input Device	Input data levels. A high represents a binary ONE, a low represents a ZERO. All printable characters (i.e., codes having a ONE in DATA 6 or DATA 7) are stored in the printer buffer. Control characters (i.e., codes having a ZERO in both DATA 6 and DATA 7), are used to specify special control functions. These codes are not stored in the buffer except when they specify a print command and are preceded by at least one printable character in that line.
3, 21	DATA 2	Input Device	
4, 22	DATA 3	Input Device	
5, 23	DATA 4	Input Device	
6, 24	DATA 5	Input Device	
7, 25	DATA 6	Input Device	
8, 26	DATA 7	Input Device	
9, 27	DATA 8	Input Device	
10, 28	<u>ACKNLG</u>	Printer	Acknowledge pulse indicates the input of a character into memory or the end of a functional operation.
11, 29	BUSY	Printer	A level indicating that the printer cannot receive data.
12	PE	Printer	A level indicating that the printer is out of paper.
13	SLCT	Printer	A level indicating that the printer is selected.
14	$\pm 0V$	Printer	(Formerly SS signal older version)
15	CSCXT	Printer	A 100 KHz (Models 101, 101A, 102A, 101S) or 100-200 KHz (All other models)
16	$\pm CV$		
17	Chassis Gnd		
18	+5V		
31, 30	<u>INPUT PRIME</u>	Input Device	A level which causes the printer to be primed. (Not in 101)
32	<u>FAULT</u>	Printer	A level that indicates a paper empty, light detect, or a deselect condition. (Not in 101)
34	Line Count Pulse		Both sides of the line count switch appear at the interface connector. This switch is opened and closed during each line feed operation. A level delivered to the switch would be pulsed off and on each time a line feed operation is performed. (Series 300 and 500)
35	Line Count Pulse Return		(Series 300 and 500)
36	Not Used		

\*Second pin number indicates twisted pair return ( $\pm 0V$ ).

\*\*Active low signals are specified by a line over the signal name. Active high signals have no line.

### B3. BASIC SIGNAL SPECIFICATIONS

#### Logical TRUE

A high signal is defined as a logical TRUE or a logical ONE if it is in the range of +2.4 volts to +5.0 volts, not to exceed a peak positive voltage of 5.5 volts.

#### Logical FALSE

A low signal is defined as a logical FALSE or a logical ZERO if it is in the range of 0.0 volt to +0.4 volt, not to exceed a peak negative voltage of -0.5 volt.

#### Level

A signal which is present for two or more clock times or whose pulse width is not critical is defined as a level (e.g., the data inputs).

#### Pulse

A signal whose width is critical is defined as a pulse (e.g., DATA STROBE) and the width is specified. Pulse width is measured at +2.4 volt for a true condition and +0.4 volt for a false condition.

#### Delay Time

Delay time is defined as the interval between the specified signal at the receiving end of a cable and reference signal in the receiving unit. It is measured at the +2.4 volt point for a logical ONE and +0.4 volt for a logical ZERO.

#### Switching Time

Switching time is defined as the rise or fall of a signal, whichever is greater. It is specified between +0.4 volt and +2.4 volts. Maximum switching time for signals is 0.2 usec (not including set-up and hold times).

#### Current Requirements

For a high input signal to the printer, the input device must be able to source 0.320 milliamps at +2.4 volts. For a low input, the input device must be able to sink 14 milliamps.

For a high output from the printer, the printer can source up to 0.320 milliamps at +2.4 volts. For a low output, the printer can sink up to 14 milliamps.

#### Line Terminations

Data lines are terminated in the printer by 1000 ohms to +5 volts. DATA STROBE and INPUT PRIME lines are terminated by 470 ohms to +5 volts.

## B4. POWER INPUT AND GROUNDING SPECIFICATIONS

### Input Voltage

Voltage requirements for the printer are:

115 VAC  $\pm 10\%$ , 60 Hz or,  
230 VAC  $\pm 10\%$ , 50 Hz

The printer shall be independently connected to the primary power source by means of a 3-wire grounded outlet and shall contain conversion, regulation, and sequencing equipment required for correct performance.

The turn-on surge current in all Centronics printers takes the form of a decaying exponential waveform, with approximately a 250 millisecond time constant. The values of the initial surge current and the steady state operating current (with the printer not printing) are shown in the following table.

Model	Surge Current	Operating Current (with printer not printing)
101/101A	48 amps (max. peak to peak)	2.8 amps (RMS)
102A	52 amps (max. peak to peak)	3.3 amps (RMS)
306	28 amps (max. peak to peak)	2.3 amps (RMS)

### Equipment Ground

The green wire (building ground) of a power cable for the printer shall be securely fastened to the frame. The white wire (neutral AC) shall not be grounded to the frame.

### D.C. Ground

The return wire of the interconnecting line, twisted pair shall be grounded to the DC ground. This connection shall be made as close as practical to the signal source and load.

# VIA WEST, Inc.

2739 W. Palm Lane, Phoenix, Az 85009  
(602) 269-1953

## CSP-100 SPECIFICATION

### SIMPLIFIED EIA RS-232 TO CENTRONICS INTERFACE

#### Input

Asynchronous Serial Data EIA-Level  
1 Start Bit  
7 Data Bits plus Parity  
or 8 Data Bits  
1 or 2 Stop Bits  
See Back

Printer Input & Output Connector  
Male 36 Pin AMP (Centronic Standard)  
Cable Length 12"

#### Power

Powered from Centronics Printer  
less than 400 MA@ 5 Volts

#### Output

Parallel Data TTL Centronics  
Compatible

Operating Temperature  
+5° C to 50° C  
Relative Humidity 5% to 95%  
without condensation

#### Busy\*

Busy enabled Low Level  
Not Busy High Level

#### Mounting

Self Adhesive

#### Inverted Busy\*

Inverted Busy enabled High Level  
Not Busy Low Level

#### Size

3 7/8" W x 5 3/4" L x 1 1/4" H  
Molded Plastic

#### Baud Rates

300, 600, 1200, 2400, 4800 & 9600  
Baud Strappable  
See Back

#### Weight

13 oz.  
1 1/4 lbs. shipping weight

#### EIA Signal Connector

Male 25 Pin AMP (Standard EIA)  
Cable length - 10'

#### Option

Baud Rate Switch  
Word Structure Switch

Since the Model CSP-100 is not buffered it may be necessary to place two Null Characters after carriage return in order not to lose data due to delay in Busy Signal.

\*Two spare leads, with pins attached, are located inside EIA Connector Hood. These leads may be used to change pin assignments. For example; to change busy from pin 20 to pin 11, you would simply snap one of the spare wires into hole 11 on the EIA Connector and then replace the orange or brown (busy, inverted busy) wire at the Circuit Board with selected spare. Tap the removed orange or brown wire. Unit is strappable for busy or inverted busy. See back.

Warranty - 90 day Factory, parts & labor.

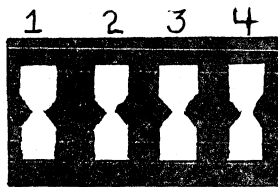

Function	1	2	3	4
7 Bits	X			
8 Bits	0			
Odd		X		
Even		0		
1 Stop			X	
2 Stop			0	
Parity				X
No Parity				0

X- Inserted  
0- Removed

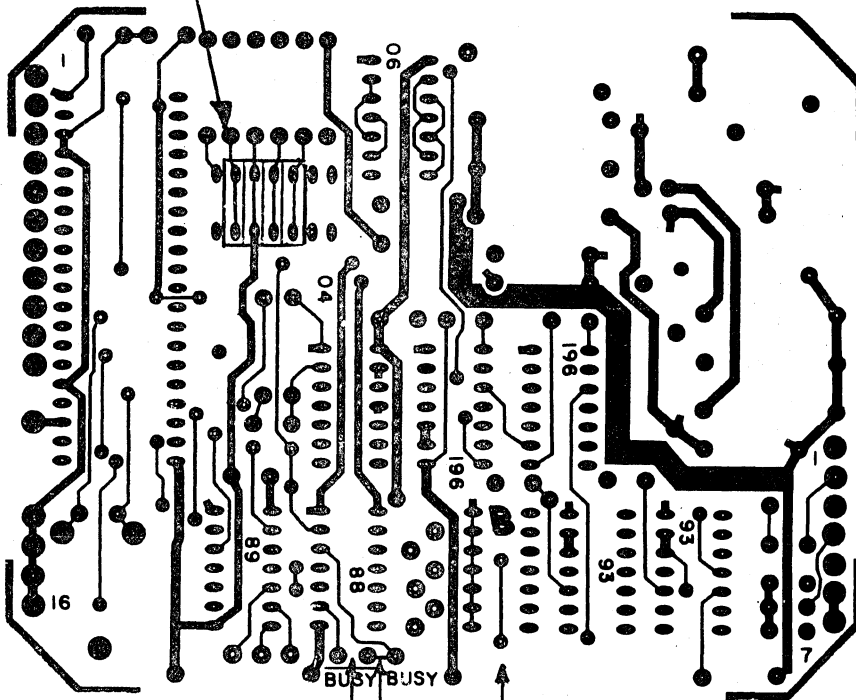

Invert Busy  
Insert Strap  
Cut Trace on  
back of board

Via West Standard

1200 Baud, 7 Data Bits  
Odd Parity, 1 Stop Bit

Baud Rate Strapping

- 0 0 - 600
- 0 B 0 - 4800
- 0 0 - N/C
- 0 0 - 2400
- 0 0 - 1200 Std.
- 0 0 - 300
- 0 0 - 9600

Select only one



# **CENTRONICS**

**centronics data computer corp.**

**hudson, n.h. 03051**

**telephone (603) 883-0111**

**eastern region: (617)272-8545 (mass.)**

**central region: (513)294-0070 (ohio)**

**western region: (714)979-6650 (calif.)**

**centronics data computer (canada) ltd.**

**mississauga, ontario (416)625-0770**

**centronics data computer (u.k.) ltd.**

**cheam, surrey (01)643-0821/7**

**centronics data computer (germany) gmbh**

**6 frankfurt/main 663321/2**

© Copyright 1976 Centronics Data Computer Corp.  
All rights reserved  
Patents pending in USA and other countries.

(Printed in USA 3/76)

Specifications subject to change without notice.