

Good Stuff

ISSUE NO. 2

This document contains sensitive information which shall not be disclosed to personnel outside of Digital Equipment Corporation.

This Newsletter is meant as an information document. It's contents are not necessarily Company Policy. It's a means by which LCG Product Support can distribute some tidbits of information to you.

I WANT IT

To receive your very own copy of GOODSTUFF you must be on the distribution list. Pretty clever - right?? To get on the distribution list send a twx or memo to Bill Buck or Sue Rozal in Marlboro - MR1-1/S35. We need your name, badge number, and cost center.

TECH DOC NEEDS HELP!!!

by: Art Johnson/Bob Smith

A preliminary version of the KL10 Maintenance Handbook has been distributed to the field. Would each person who is using, or intends to use, this book please do the following:

1. First of all, look at the Table of Contents and page through the book. See what the handbook contains now.
2. Next, based on your requirements and past experience, determine what material should be added to the handbook to make it a more useful tool. For example, should troubleshooting charts or procedures be added? Should diagnostic abstracts be added? You tell us.
3. Finally, if you do have suggestions or (better yet) actual material you want added to the book, mail to:

Art Johnson/Bob Smith
MR1-2/T17

Remember, this handbook is a benefit to you but its success also depends on you. Please make the effort to contribute and do it as soon as possible. We need your help. Thank You.

Editor	Bill Buck
Assoc. Editor	Sue Rozal
Artist	Sue Rozal
Editorial office	MR1-1/S35

GOODSTUFF is published monthly or whenever we can get enough good stuff together to make the hassle of production worthwhile.

WHERE SHOULD YOU STICK YOUR SBUS?

This is a reminder that the SBUS cable from the CPU to a DMA20 must be in CPU slot 3 (SBUS1) while the SBUS cable from the CPU to an internal (MA/MB20) memory controller can be in either CPU slot 2 or CPU slot 3. This is because the CLK EXT signal is only supplied to SBUS 1 while the CLK INT signal is supplied to both SBUS0 and SBUS1.

Troubleshooting tip: Remember that the translators for the two SBUS's are in parallel. Therefore, on machines with internal memory you can swap SBUS translators by swapping the SBUS cables in the CPU to the unused position (either slot 2 or 3). This cannot be done on a machine with a DMA20 because of the above mentioned restriction on clocks.

SHOULD MH10'S "WARN" KL10'S?

To adjust DATA WARNING on MH10/KL10 systems, you must enable the DATA WARNING DELAY by grounding the appropriate pin for the port in question:

L39U2 for port 0	L32U2 for port 1
L38U2 for port 2	L31U2 for port 3
L37U2 for port 4	L30U2 for port 5
L36U2 for port 6	L29U2 for port 7

Adjust the upper delay on the M8591 address receiver module for each port to obtain a delay from DATA WARNING to RD RS of 310 nsec. The print set gives this figure to be 250 nsec. However, the KL10 will not run at clock source one unless the delay is set at about 310 nsec.

USING MAPOUT UNDER DDRPI

MAPOUT is a program which runs in exec mode under DDRPI that updates and/or reports the contents of pack BAT blocks. To successfully use it, you must first run a test such as RONLY so that the diagnostic has a mapping of bad spots on the pack. After running one pass of RONLY, run MAPOUT and answer the questions appropriately. Note that with TOPS-20 release 2, you will have to use MAPOUT to create BAT blocks or you won't be able to define a structure. Also, the next release of DDRPI will allow you to run MAPOUT in user mode (TOPS-10 now, TOPS-20 with mountable structures).

CAN'T TALK TO YOUR MAGTAPES ON DECSYSTEM-20's?

Recently a TOPS-20 monitor patch was published in the LARGE BUFFER which cured a problem relating to J0NRUN bughalts. If the published patch is installed, you will no longer be able to use your tape drives. The patch and the correction are given below:

PUBLISHED PATCH:

RUNDD5/MOVEI T1,103

change to MOVEI T1,101

PHYSIOS:

SIO2 +4/TLNE P3, 100000

change to JFCL

SEK1 +2/CAME T2,24(P3)

change to JFCL

THE CORRECT PATCH:

RUNDD5/MOVEI T1,103

change to MOVEI T1,101

PHYSIOS:

SIO3-1/JRST SIO4

change to JFCL

SEK1 +2/CAME T2,24(P3)

change to JFCL

No change is made to SIO2 +4

DC20-EC COMMUNICATIONS EXPANSION CABINET POWER REQUIREMENTS

The DC20-EC uses an 861-D power control unit. This is a three phase, 30 amp unit which requires a NEMA L21-30R receptacle.

BAC-UP AND TRY AGAIN

If your system is getting BAC stop codes and you are at the end of your rope - then try MCO 5934. Make sure you install the complete MCO. The KI tag applies to KL10 monitors. Both 602 and 602A monitors should have this MCO installed.

INSTALLATION SHORT SHIP

There appears to be some confusion over what constitutes a short ship, and what procedures are to be followed when one occurs. A short ship exists whenever a hardware or software item that is listed on either an SBA, transfer sheet, cable or accessory list is missing at the time that the shipment arrives at the customer site.

In view of the above definition it is imperative that Field Service inventories each piece of equipment, and all containers, against all shipping documents to ensure everything listed has been received. A "P-1" short ship request for any shortages discovered at this time should be placed through the local logistics administrator.

If items needed for the installation are missing, but are not listed on any supporting documents (i.e., additional cables not originally ordered), the request should NOT be placed through the logistics administrator, but forwarded immediately to the account salesman. In this case manufacturing shipped what was ordered and any attempt to obtain needed items through the normal short ship procedures will result in the request being rejected by manufacturing. The needed items can best be obtained through the salesman and the product line, who will generate the needed authorization for manufacturing to ship the additional items.

If you find you are missing items that do not appear on a shipping list, and are not normally ordered as part of sales processing cycle, or have otherwise been omitted from the shipment, please document the occurrence, and send the information to Art O'Donnell MR1-1/S35 ext. 6231.

Items that should not be ordered as short ships, are:

1. Items that are D.O.A. or fail during systems test.
2. Spare's.
3. Equipment damage in shipping.
4. Expendables.

Please keep those installation reports coming. If you have not received the installation report forms, substitute one of your own. Any suggestions, problems, or other important information concerning installation quality can be sent to my attention at the above address for action.

PROBLEMS LOADING MICROCODE WITH VERSION 12 OF KLDCP

If you have an M8525 at Revision F in your machine and you're running KLDCP Version 12, you will have problems loading the microcode. At Revision F, the M8525 underwent a relayout. Part of this relayout included provisions for extended addressing. To load the microcode, KLDCP performs a master reset routine. Part of this routine is a function read to determine if the extended addressing option is present. With the Revision F modifications to the M8525, KLDCP always thinks extended addressing is present and attempts to load the microcode accordingly. This causes errors in verification. At this time, there is no patch to correct the problem. However, one will be published when it is available. Warning: Versions 13 and 14 of KLDCP also have the same problem.

H744 REGULATOR FCO

Smoking H744 regulators may be hazardous to your computer's health. There is a solution to correct this problem: FCO H744-R0019. This FCO adds a jumper across a portion of the circuit board etch which acts as a parallel current path.

This FCO is available through logistics (Stockroom 17). It should be installed in all H744 regulators used in DECsystem-10 and DECsystem-20 options as soon as possible. The time to install and test this FCO is approximately one hour per regulator.

THE ELUSIVE EXTENDER

In the beginning, extender modules for KL10's were non-existent. Then they were very difficult ... then difficult ... and now!!!, they are here.

There are two models of the extender module; the W9017 (straight) and the W9017-YA (right angle). The straight extender is needed for KL10's while both extenders are required for DECsystem-20's.

The extender module for 1080/1090 systems should be stocked at the site. The extender modules for DECsystem-20's should be stocked with the branch spares.

If you have ordered these modules and they have been "no-filled" for more than six months you should resubmitt the order.

PATCH THE DIAGNOSTIC INDEX

Diagnostic Engineering is in the process of developing an Index System that will be much easier to use than the present index. The present index, microfiche DDXXA, is confusing and difficult to use - to say the least.

The new index will be released to the field in the next month or two. The new index will also be called DDXXA and will replace the existing file. This index will provide five sort modes to search for diagnostic information. The five modes are MAINDEC, DEVICE, 10 CUSP, 11 CUSP, and FLOPPY.

The first sort mode, by MAINDEC, will list all diagnostics for DECsystem-10's and DECsystem-20's in alphabetical order. Additional information provided will be:

1. The SDC unified numbering code.
2. The device the diagnostic tests.
3. The 10 CUSP tape (if applicable).
4. The 11 CUSP tape (if applicable).
5. The FLOPPY name (if applicable).
6. The diagnostic magtape name for DECsystem-10's and/or DECsystem-20's.
7. Whether the diagnostic is contained on the KLAD 10 and/or the KLAD 20 pack.
8. Comments section.

The above information will also be listed in the other four sort modes.

The device sort mode will list devices in numeric (i.e., 11/40, 2040) order followed by an alphabetical sort of devices. E.G. KL10, DC10, RP04.

The remaining modes will sort the 10 CUSPS (DECTapes), 11 CUSPS (DECTapes), or FLOPPIES (Diskettes) alphabetically. Again, the eight information fields listed above will be referenced.

This index will allow great flexibility in searching for diagnostic information. By knowing only one piece of information it will be possible to obtain all the related information about that diagnostic.

The second important piece of diagnostic information is contained on the microfiche DDXXB. This document is the Diagnostic Deficiency List and details known diagnostic problems. This microfiche lists, alphabetically, the diagnostics, the problem, and a status code. The usage of this document is explained in a text file at the beginning of the microfiche.

The microfiche DDXXC, which listed differences between diagnostic release tapes, will be discontinued with the introduction of the revamped microfiche DDXXA.

**DN87-S UNIBUS ...
HOW LONG IS LONG?**

If the following general guidelines are followed the confusion regarding UNIBUS loading on DN87-S systems will be eliminated.

1. The electrical length of the UNIBUS from the CPU (11/40) to the DB11 Bus Repeater may not exceed 25 feet.
2. The maximum number of Bus Repeaters on a DN87-S system is two (2).
3. The maximum electrical bus length from the DB11 to the DTE may not exceed 50 feet.
4. The maximum number of "unit loads" before a Bus Repeater is necessary may not exceed 18.
5. When counting device "unit loads" consider the DTE as 2 unit loads.

NOTE:

At least one DB11 Bus Repeater must appear in the DN87-S system.

Physical length is the measured length of the UNIBUS cable.

Electrical length is the length of the UNIBUS plus the characteristics bus length of each option. A device having the loading effect of 1 unit load uses the approximate equivalent of 2.8 feet of UNIBUS cable.

**WANT TO USE 6.03/RSX20F
FOR YOUR 1080/1090
SYSTEM?**

In order to boot the 6.03/RSX20F monitor, as well as "new" KLAD packs, the existing M873-YD bootstrap loader module in the console processor must be replaced. The replacement module is the M873-YH bootstrap loader module. The new module may also be used to boot "old" KLAD packs and/or earlier monitor releases.

The FCO M873-R0005 will contain all the parts, documentation, and diagnostics required: two M873-YH modules, the latest version of the 1080/1090 Front End Cusp DECTape (containing the M873 tests), and the latest version of the revision 9 diagnostic magtape.

This magtape will be used to update the KLAD pack as well as the system Front End pack. When the kit for this FCO is ordered, either a 7 track or 9 track magtape must be specified.

As soon as this FCO is released for field distribution the Regional FCO Co-ordinators will be notified by TWX.

CRAM YOUR KL

The K LHUNG command string can give erroneous print out of the CRAM word. For example, a common CRAM address of a hung KL10 is 0006. Often the microword will be printed with a SCAD field of 000, where in version 131 of the microcode it should be 040. In fact, the bit in this field is the parity bit. Further investigation will show that there was no CRAM parity error and an "EC 0006" will print the true value of the microword. So ... always double check on such anomalies!

DDANA-AN10 DIAGNOSTIC

The IMP TEST code in DDANA is now in place and can be run by answering "I" to the "What options?" question when initially starting the diagnostic. It will allow you to select various parameters (such as message length, data pattern, etc.) by prompting with appropriate questions.

The following procedure was used for verifying the timing of the LS221 one-shots on the M8614 module in the AN10 at USC-ISI. It may be helpful to you.

SIGNAL	CHIP-PIN	RANGE
ICON DESKEW DELAY	E01613	40-90 nsec
ICON DLY CLK	E01605	80-160 nsec
ICON LOCAL BIT DLY UP	E01113	60-130 nsec
ICON RDY FOR I BIT CLK	E03705	40-90 nsec
ICON RDY DWN TIME DLY	E00413	160-275 nsec
ICON DATA PAD DLY	E02813	40-90 nsec
ICON DATA PAD CLK	E07213	80-160 nsec

All but the PAD timers can be measured by installing the AN10 local loopback connector and executing test 74 of DDANA. The DATA PAD timers can be measured while running test 70.

Also, when the AN10 is receiving data, the time from the negation of ICON SHFT DATA H (E05903) to the negation of ICON RDY DWN TIME DLY (E00413) should be greater than or equal to 75 nsec. This can be checked using test 74. You can also check the following: When the AN10 is data padding, the time from the negation of ICON SHFT DATA H (E05903) to the negation of ICON RDY DWN TIME DLY (E00413) should be, again, greater than or equal to 75 nsec. This can be checked using test 70.

SELF-PACED AUDIO/VISUAL COURSE

by: Greg Barker

As of August, 1976, Educational Services had made the following self-paced Audio/Visual courses available for in field training:

- Introduction to Minicomputers
- Introduction to PDP-11
- Introduction to Data Communications
- Magnetic Recording Techniques
- Disk Principles
- Tape Concepts

These courses are presented in mixed-media of audio filmstrip cartridges and workbooks.

The cartridges display sharp, full-color graphics on filmstrips (all graphics were designed and produced on a minicomputer-controlled system) synchronized with clear, concise narrative. These courses are interesting to watch and easy to comprehend. Workbooks supplement audio/visuals with additional reading. Reinforcement exercises provide feedback essential in the learning process. Students work back and forth between the audio/visual program and the workbooks, a method of learning that adds variety and interest. The results is an integrated listening, viewing, reading, and writing experience.

The self-paced approach allows for thorough learning of material at a speed that is comfortable for the individual. The course is as close as your library bookshelf, and people can learn at their own convenience. In the field this means you can eliminate the time and expense of traveling to educational centers. You can also maintain project continuity by staying on the job.

Brouchures which describe the courses are available from any Regional Educational Service Training Center. These pamphlets contain course descriptions as well as interesting and informative material on self-paced courses and their impact on training in general. Specific ordering information is also included.

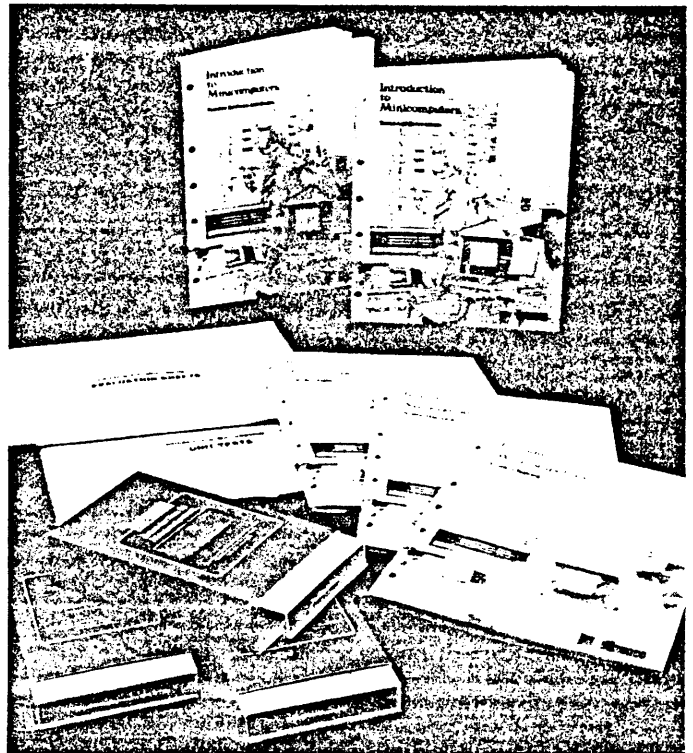

A small portion of actual course material.

LC REV (WHAT-WHERE-WHY?)

What is LC REV? Where is LC REV? And Why do we need LC REV? Let's start by answering the easiest question, "Where?", first.

This information is contained in the LCG Microfiche Library in the miscellaneous section (purple heading). There is currently one microfiche that details the revision information for the KL (CPUA, DMA/DIA, DTE, and RH/DTE) and revision information for independent units such as memories (MG10, MH10) disks (RP04, RP06), controllers (DX10, LP20), etc.

The LC REV information will remain in the same location but shortly there will be 2 microfiche: the first will contain KL "Integral System" Revision Level information, the second will contain the information for independent units.

Now that "Where?" has been answered, "Why?" is next. In the past when an engineering group wrote a field effect ECO an FCO would be generated to implement that ECO. This system worked fairly well, with minor exceptions, because there were very few inter-related ECO/FCO releases. When the KL "Integral System" was designed inter-related ECO/FCO releases became the rule instead of the exception.

The CPU, DTE, DMA/DIA, and RH/DTE), as well as diagnostic and microcode versions, became so inter-meshed that one "piece" could not be changed without affecting something else. So LC REV was developed to tie all the pieces together. An added benefit is that instead of having to keep track of approximately 65 separate FCO's (not including diagnostic and microcode changes) there have been 8 KL "Integral System" revisions released with 2 more, 9C and 10, soon to be released to track.

This same philosophy was applied to some of the newer independent units. A problem with controlling some of these units is that LCG Engineering does not have total design/ECO control. For example, changes to the MA20-M stacks may be implemented and suddenly the MG10 Revision Level is not correct. Issues of this type, however, are being identified and solutions implemented so that the independent unit revisions will be as accurate as those of the KL "Integral System".

The microfiche containing KL "Integral System" Revision Level 10 will be different than it's predecessors. The concept, as well as the format, have been changed. The changes to the format were made to make the document easier to use. The conceptual changes were implemented to make the control system more flexible and therefore more adaptable for possible future applications. (con't)

The current concept dictates that all units within the "Integral System" will be at the same revision level. For example, the DMA/DIA, DTE, and RH/DTE where advanced from Revision 8 to Revision 9 even though only the CPU and diagnostics were affected by KL "Integral System" Revision Level 9.

Under the new concept there will be an "Integral System Top Revision Level" that will control the proper revision levels for the CPU, DMA/DIA, DTE, and RH/DTE as well as diagnostic and microcode revisions. Only if a unit within the "Integral System" is modified will its revision level be changed. For example, an "Integral System Top Revision Level" of 12 could contain a CPU at Revision 12, a DMA/DIA at Revision 10, a DTE at Revision 11 and a RH/DTE at Revision 12.

A module revision level/"Top Revision Level" matrix is included in the section titled LCCOMP. This matrix indicates which module revision levels may, or may not, be utilized in a given "Integral System" revision.

A section titled "Related FCO's" will list FCO's that are required by the "Integral System" but are not related to any "Top Revision Level". Entries in this section will typically be for power supplies or regulators, cables, etc.

A much more detailed explanation of the "What?" of LC REV is at the beginning of the revision documents. When you receive the next update of LC REV (microfiche revision 8) it is recommended that you look at the available information before you file the 'fiche away. If you have questions, comments, or "whatever", please call Bill Buck (MR ext. 5148) in the LCG Field Quality Group. Our concern is that this information will be of value to Field Service. Without your involvement we cannot do any more than has already been done. Communication must be a "two way street".

KLDCP ... 1, 2, 3

The MZ command to KLDCP has some limitations:

1. It only clears a 64K segment of core.
2. It does not clear the last location in the 64K segment.
3. A better solution to clearing core is to use the following program:

```
0/0,,0
```

```
1/2,,3
```

```
2/DATA; 0 for clearing core
```

Then "EX 251040, 777777"; BLT from AC1, ending address of 256K.

NEW VERSION OF SYSERR

SYSERR version 7 (435) is being released with the TOPS-10 6.03 and TOPS-20 Release II monitors and fully replaces all earlier versions. The latest version of DAEMON for use on TOPS-10 6.03 is version 15 (574). Significant new functions include:

1. "/NDEV:" switch - this is the opposite function of the "/DEV:" switch.
2. List all register contents even if 0.
3. "/DEV:" support for device type, not just device name. Using just the "/DEV:" switch with a device type such as RP04 and without a listing switch such as "/MASALL" will cause all entries concerning an RP04 to be listed. Currently available device types include CPU, KLCPU, KLERR, 11CPU, RP04, RP05, RP06, LP100, RP02, RP03, RD10, RM10, RS04.
4. Support for LP100 under TOPS-10 - listings are obtained via "/URDALL" or "/DEV:LP100" switches.
5. For TOPS-20, logical assignment of SYS to <SYSTEM> is no longer required.
6. Contents of CRAM are provided in KLERROR listings.
7. For TOPS-20, 1st 10 "good data" words are listed during memory sweep printout if it was available. A listed value of 0 states the good data was not available.
8. For TOPS-10, a new entry, DAEMON started to differentiate between DAEMON restarts and system reloads.
9. For TOPS-10, a new entry which is comprised of selected information extracted by DAEMON from a crash file. Included are any pending entries which were not appended to the error file before the crash and lots of summary information concerning the monitor load period.

Perhaps the most important is section 9. The summary information includes total activity and error counts for the entire disk system, uptime and usage information (the performance subtable) and all parity information. This report can provide a very complete picture if every interruption (such as crash, reload, down for PM, etc.) is saved. DAEMON, upon startup, looks for CRASH.EXE which it hasn't processed yet and extracts this information. The key to total success is 'saving' the core image each time you stop the monitor. (con't)

If any bugs are discovered or if you have any ideas on how we can improve SYSERR, please use an SPR (Software Performance Report) rather than anything else (unless it's an emergency). A reminder, SYSERR is fully supported, Category A software and the fastest form of feedback is the SPR.

INSTALLATION AND WARRANTY CHARGE POLICY

by: Mike Flitterman

There is some confusion in the field over installation charges for add-ons and upgrades to both DECsystem-10's and DECsystem-20's.

This is an attempt to clarify the confusion, once and for all. Please make sure that your people are fully aware of these policies.

(1) DECsystem-10

- New Systems: Installation charges are incorporated in the MLP. All costs associated with the installation will be charged to "W" by the F/S Branch. F/S Branches will not receive income for installation.

- Add-ons/Upgrades: On all delivered after July 1, 1977 -- same as new systems. (Up until July 1 -- there is no charge.)

There is no warranty period for DECsystem-10 systems or add-ons/upgrades.

(2) DECsystem-20

- New Systems: Installation charges are incorporated in the MLP. All costs associated with the installation shall be charged to 'W' by the F/S Branch. F/S Branches will not receive income for installations.

- Add-ons/Upgrades: Installation charges are in addition to the MLP and must be so noted as a separate line item on the MOF and charged to the customer. This will be "I" income for the installing F/S Branch. The installing F/S Branch will use the "I" code for all labor related expenses incurred during installation up to the Date of Installation (DOI). Date of Installation is defined as the time the add-on or upgrade has successfully passed the DEC standard diagnostic acceptance tests. Costs incurred after DOI by the installing branch, due to software or additional acceptance requirements, will be charged to "W". All parts requirements will be charged to "W".

There is a 90-day warranty on all DECsystem-20 purchases.

KL REVISION 10

Revision Level 10, due to be released in August for production and for Field Service Installation, reworks six modules, the CPU Backpanel, and phases in two modules. The six modules being reworked are the M8513, M8524, M8530, M8533, M8558, and M8560 modules. The M8519 and M8553 modules are being phased into production. The backpanel rework consists of one TWP delete and a single wire add.

The problem with the M8513 module is that the MAP Instruction sometimes causes a CACHE Parity Error by generating an extra "CACHE IDLE IN C" signal when a hardware page table refill has to be done. To inhibit the extra "CACHE IDLE IN C" signal, the signal "PAG4 PAGE OK" instead of "PAG4 PAGE REFILL" is used to generate a new signal "CSH3 MAP" instead of "CSH3 MAP REFILL".

There are two etch revisions of this module. The rework for the original etch revision of the M8513 module consists of 8 etch cuts, 3 component adds, and 8 TWP adds. The new etch revision rework consists of 10 etch cuts, 3 component adds, 8 TWP adds, and 1 single wire add.

The FCO rework instructions will cover both etch revisions. Both revision modules are downwards compatible.

The M8524 module fails when a prefetched instruction page fails (at NICOND time). The microcode branches to locations 1777 and does not save the "TRAP FLAGS" in the "CYCLE" flops on the M8524 module because the page failure inhibits the clock on that module. When the page fail microcode tries to restore the "TRAP FLAGS", the trap information is lost thus preventing a trap after the page failure is handled. To correct this problem the "CYCLE" flops are inclusive or'ed with the "REQUEST" flops on instruction aborts.

The rework consists of 11 etch cuts, 9 wire adds, 1 component add, and 1 component delete. The reworked M8524 module is not downward compatible.

The M8530 module, when used in a system running a TOPS-20 monitor, will not allow more than 256K of memory to be used because (on the MCL and VMA boards) loading the physical address loads only VMA bits 18-35 instead of 13-35. The solution is to modify the module to load VMA bits 13-35.

The rework for the M8530 module consists of 11 etch cuts, 8 wire adds, 1 component add, and 1 TWP add. The reworked module is not downward compatible.

The M8533 module suffers from two problems. First, "C BUS ERR" goes away when READY drops. Therefore "C BUS ERR" may not be asserted. The second problem is that some signals are a bit on the slow side. (con't)

The solution for the first problem is to use "C BUS READY E H" instead of "READY" as a gating signal. The solution for the second problem is to use an earlier occurring gating signal.

The rework for the M8533 module consists of 4 etch cuts, 5 wire adds, 1 TWP add, and 1 TWP delete. The reworked module is not downward compatible.

The M8558 module requires that the 10 SBUS terminators be changed from 180 OHMS to 150 OHMS for more reliable operation. This module is downward compatible after it is reworked.

The M8560 module has two problems. The first requires that the 17 SBUS terminators be changed from 180 OHMS to 150 OHMS. The second problem, a reliability problem of delay line DL6, is corrected by increasing the delay time. This module is downward compatible after it is reworked.

The two modules being phased-in, the M8553 and the M8519, are both downward compatible. The M8519 module is a new board layout of the existing module. The new M8553 module is required only when using a PDP11/34 Secondary Front End.

IS YOUR KLHUNG?

Using the J KLHUNG command string to dump a hung or crashed KL10 may result in losing some valuable information due to problems in the structure of the command string.

On the KL10 A/B a better approach is to do the following:

1. FX0 (Stop Clock)
2. FR100,177 (Read all KL Diag. Func.*)
3. ALL (Read all major KL reg's)
4. FX1 (Turn on Clock)
5. AC BLK7 (Select AC.BLK 7)
6. EM0,1 (0 =AR;1 =ARX See KL-TT-4)
7. AC BLK0 (Select AC BLK 0)
8. EX 700400,1 (Read Error Reg)
9. EM1 (Examine Error Reg)
10. DM6:100000,0 (Set up AC for SBUS Diag)
11. EX 700500,6 (Read SBUS Diag Func 0)
12. EM7 (Examine SBUS Diag Func 0)

*BEWARE: Signals suffixed by "L" will be "0" when true.

It is important to impress on your customers that they should not perform MR resets before loading KLDCP or taking a dump themselves. The KLHUNG.CMD file is still useful as a customer tool, but the above procedure (which is modified for KLHUNG) will provide more information to enable analysis.

COMPANY CONFIDENTIAL

KLAD 20 PACKS

There has been a recent rash of P1's for KLAD 20 packs. Our response has been to ensure that these orders are filled, despite any impact on production, and to ask questions afterward.

"Now the time is afterwards and the question is, are these all necessary?"

It is relatively easy to destroy the 20 side of the pack, and relatively hard to destroy the 11 side.

If the 11 side is intact and if the site engineer has saved the 20 side on magtape the pack can be recreated on site following the procedure shipped with the system. The file "KLAD 20.MEM", contained on the KLAD pack, and the software installation guide describe the procedure for "saving" and "restoring" the "20" side of the KLAD pack.

If you boot a system from a KLAD pack and you get as far as receiving a message "Boots loaded and started" and then nothing else your Front End 11 files system is probably intact, and you probably have residual bad parity in physical memory. Zeroing all of memory and AC Block seven will probably allow you to come up.

If you boot a system, get the previous message, and then get the message "Boot" followed by an error message, the 20 file system has been "clobbered".

If this is the status, the file system can be repaired with phone assistance from Bernie Eiben (617) 481-9511, ext 6291, or replaced by using the magtape save of this structure.

If you have problems with your KLAD 20 pack please contact Bernie for assistance or advice. This will ensure that we do not impact production for unnecessary P1 orders.

THE A B C 's OF KL NUMBERING

As living languages spawn dialects and these dialects create communications difficulties, so it is with KL Engineering Designations as some of you have already experienced.

The purpose of this article is to get us all back to the basics of KL nomenclature and hopefully make it easier to understand the designations.

BASIC INTEGRAL SYSTEM NOMENCLATURE DEFINITIONS

KL10-A

IS the Integral System FOR a 1080 System
NOT the CPU
NOT a 1080 System

KL10-B

IS the Integral System FOR a 1090 System
NOT the CPU
NOT a 1090 System

KL10-C

IS the Integral System FOR a 2040 or 2050 System
NOT the CPU
NOT a 2040 or 2050 System

KL10-D

IS the Integral System FOR a 109? System
NOT "ANNOUNCED" therefore "Company Confidential"
NOT the CPU
NOT a 109? System

KL10-E

IS the Integral System FOR a 2045 or 2055 System
NOT "ANNOUNCED" therefore "Company Confidential"
NOT the CPU
NOT a 2045 or 2055 System

KL20

"NOT" ANYTHING - NEVER WAS; DON'T SAY IT, WRITE IT,
but correct it when you read it

MODEL A

NOT a designation (refer to KL10-PA - CPUA)

MODEL B

NOT a designation (refer to KL10-PV - CPUB)

BASIC UPGRADE DEFINITIONS

KL10-PM KIT

NOT a Kit to PM KL's
NOT an FCO Kit
IS a Kit to upgrade KL10A's at LCREV 9A to KL10B's

KL10-PV KIT

NOT a Kit to PV KL's
NOT an FCO Kit
IS a Kit to upgrade KL10C's at LCREV 10A to KL10E's at LCREV 2

COMPANY CONFIDENTIAL

KL10 INTEGRAL SYSTEM TABLE

KL10-A (1080)	KL10-B (1090)		KL10-D (1090)	KL10-E (2045/55)
CPUA	CPUA	CPUA	CPUB	CPUB
DTE20	DTE20	DTE20	DTE20	DTE20
	RH20	RH20	RH20	RH20
DIA20	DIA20		DIA20	
DMA20	DMA20		DMA20	
CACHE	CACHE	CACHE (optional)	CACHE	CACHE (optional)
		MA/MB20		MB20
TALL CAB	TALL CAB	HIBOY CAB	TALL CAB	HIBOY CAB
11/40	11/40	11/40	11/40	11/40
32K MF11/MM11-UP	32K MF11/MM11-UP	32K MF11/MM11-UP	32K MF11/MM11-UP	32K MF11/MM11-UP
DL11E	DL11E	DL11E	DL11E	DL11E
RH11	RH11	RH11	RH11	RH11
		LP20		LP20
TC11/TU56	TC11/TU56	RX11/RX01	TC11/TU56	RX11/RX01
BM873YD/YH	BM873YD/YH	CD20 BM873YF	BM873YH	CD20 BM873YF
TOPS10	TOPS10	TOPS20	TOPS10	TOPS20
DG DIAGS	DG DIAGS	DG DIAGS	DH DIAGS	DH DIAGS

1. Please communicate using basic integral system and upgrade nomenclature as previously specified where it is applicable.

2. Please contact LCG PRODUCT SUPPORT QUALITY CONTROL (MR1-1/S35), in writing, if you have any questions regarding this article or if you are supporting any KL Integral System not defined in the table. (ARPANET Integral System is not specified.)

3. Integral System (in this context) is defined as the three "10" or "20" cabinets containing CPU, Front End, Integral Channels, etc.



Good Stuff

ISSUE NO. 3

This document contains sensitive information which shall not be disclosed to personnel outside of Digital Equipment Corporation.

This Newsletter is meant as an information document. It's contents are not necessarily Company Policy. It's a means by which LCG Product Support can distribute some tidbits of information to you.

WHERE THERE IS SMOKE
THERE IS FIRE?

BY: RON MINEZZI

CORPORATE PRODUCT SAFETY

This age old axiom can result in concern by customers. Smoke certainly denotes burning although open flaming may not occur. The real concern is "DOES A HAZARD EXIST IF SMOKE IS PRESENT?". The answer is, "not necessarily", and in most cases is "no".

None the less, customers will ask and the Field Service people should know how to respond.

First of all, every field person should know how to identify and respond to potential product safety incidents. This is clearly spelled out in Section 8.0 of the Field Service Methods and Procedures Manual.

Secondly, they should all be aware that it may be necessary from time to time to explain to a customer that a smoking unit does not constitute a hazard and why it does not. An example of this is the recent failures experienced with the H744 Power Regulator.

You should always follow the procedure for responding to incidents, per section 8.0 of the Field Service Methods and Procedures Manual. However, never make statements relating to an incident unless you have checked with the Product Safety Committee.

DX10 ERROR REPORTING & 6.03

BY: RAY DRUEKE

PRODUCT SUPPORT

Part of 6.03 development included extended support for DX10 Error Reporting to handle MP Errors and others. Recently, a bug was discovered such that MP Error information is not correctly reported via SYSERR if there was no activity on the unit of the time of error. The fix is in the monitor as follows:

MCO 7179

In TX1KON at ERRUP2+1.1/2 (after an IORM instruction) insert

```
MOVSI TL,TTXFST##(U)
HRRI TL,TTXIST##(U)
BLT TL,TTXIST##+23(U) ;copy from at
                        end
                        ;to at error
                        for SYSERR
```

This fix will be included in 6.03A but may be inserted now if the situation warrants. Get help if you need it to make the patch or source level changes.

DIAGNOSTIC HOTLINE

BY: BILL BUCK

The Diagnostic Engineering Group in Marlboro has recently installed a "hotline". Field Service Engineers may call extension 6556 in Marlboro, between 8am and 5pm, for diagnostic assistance.

CAUTION - CAUTION - CAUTION
FIELD SERVICE STOP ON 1090'S

BY: JEFF GARDINER
F/S WALTHAM

A DIAGNOSIS OF THE
POLICIES AND PROCEDURES

OF THE DDC
BY: BEN BATTLE
DDC/PRINCETON

Use extreme caution when using Field Service stop on DECsystem-1090's and DECsystem-20's with customer disks mounted. If the error trap occurs during a "disk write" the RH20 will halt and the RP04 or RP06 will write the rest of the sector with zeros.

If the only program that will produce the error is the monitor, then the customer must be warned that there is a possibility that the disks will need to be restored. This would be a good procedure even if the disk does not look as though it was destroyed because the zeroed block could be a Users Directory or File and not be seen until the next disk access by that user.

A good check after using F/S stop would be to have the customer run "DSKRAT" on his system disks to check file consistency.

6.03 BUG

BY: RAY DRUEKE
M.E.G.

A bug has been found in TOPS10 6.03 which supplies incorrect SYSERR values for "BAD DATA WORD" for ARX parity errors. The fix is MCO #7443.

In KLSER at
PRTRP+26

PXCT PX.MEM, [Move T3, (T3)]
should be
PXCT PX.MEM, [Move T3, Ø]

This patch should be made at any KL site experiencing ARX parity errors and will be in 6.03A.

I. When the DDC becomes involved in any problem initiated by the Branch, causing the DDC to work directly with the customer, two things are guaranteed:

1. The DDC will get back to the Branch within 45 minutes with their findings; positive or negative. This will allow the Branch to plan the next step in their action plan and remain in control of the situation.
2. When the DDC has diagnosis results, they will be returned to the Branch. The customer will never be asked by the DDC to try and effect repairs.

II. Customers cannot call the DDC directly. All service calls must go to the Branch Office and requests must come from the Branch to the DDC.

III. The DDC's telephone number is not to be given to customers.

IV. Non-contract customers cannot presently use the DDC resources of the DDC.

Editor	William Fischer
Assoc. Editor	Susan Rozal
Artist	Susan Rozal
Editorial Office	MR1-1/S35

GOODSTUFF is published monthly or whenever we can get enough good stuff together to make the hassle of production worthwhile.

CLEARING SHADOW CORE - KL10'S

BY: MIKE FLYNN
PRODUCT SUPPORT

Clearing shadow core with a PDP-10 has always been a bit of a problem. Now, with the invention of the KL10, this problem has become more difficult because of the lack of memory switches. Here are a couple of procedures that can be used to clear shadow core.

```
WITH KLDPCP --- P U.RAM          ; LOAD MICRO-CODE.
      I CONFIG.CCL                ; CONFIGURE CORE.
      DM600/540001 540000         ; SET UP PAGE POINTER.
      DM16/0                      ; SET UP ZEROS.
      DM17/1000 1001             ; SET UP BLT POINTER.
      EX701200 20000             ; TURN ON PAGING.
      EX202700 1000              ; ZERO FIRST LOCATION.
      EX251740 1017              ; CLEAR SHADOW CORE.
```

WITH RSX20-F - "ASSUMING THAT THE MICRO-CODE IS LOADED AND THE MEMORY IS CONFIGURED"

```
      /(CONTROL BACKSLASH)        ; GET COMMAND PARSER.
      SET CONSOLE MAINTENANCE      ; GET PRIVILEGES.
      DEPOSIT TEN 600:540001540000 ; SET UP PAGE POINTER.
      DEPOSIT TEN 16:000000000000  ; SET UP ZEROS.
      DEPOSIT TEN 17:001000001001  ; SET UP BLT POINTER.
      XCT 701200020000             ; TURN ON PAGING.
      XCT 202700001000            ; ZERO FIRST LOCATION.
      XCT 251740001017            ; CLEAR SHADOW CORE.
```

TOPS20 MEMORY CONFIGURATION

BY: R.J. MALONEY
PRODUCT SUPPORT

KLI reports memory configurations incorrectly although the actual hardware is configured correctly. Below you will notice that RQ0 has address' with 01 and RQ1 has address' with 00. The hardware is sending address 00 on RQ0 and 01 on RQ1. The same is true for RQ2 and RQ3.

```
[SYO: Redirected to DB0:]
[DB0: Mounted]
KLI--Version V004A Running
KLI--Microcode Version 157 Loaded
KLI--All Caches Enabled
Logical Memory Configuration:
```

Address	Size	CONTROLLER			Contype	INT	
		RQ0	RQ1	RQ2			
000000000	256K	01	00	01	00	MB20	4
000000000	128K	03	02	03	02	MB20	4

KLI--Bootstrap Loaded and Started

This problem only manifests itself on release 2 of TOPS-20. It has been fixed in Release 3.

RE-SETTING THE DTE-20

BY: BILL HILLIARD
PRODUCT SUPPORT

It is possible for the DTE-20 to be hung in a state such that it will not allow you to do diagnostic functions. The common symptom is a response of ?DF TIMEOUT when attempting a diagnostic function. There is a method of re-setting the DTE which will not alter the state of the KL10. Re-setting the DTE will allow you to perform diagnostic operations. The DTE is reset by a deposit 100 to PDP-11 location 174432;? DE 174432:100

M8554 REV E - CONCERNS

BY: LOU NAY
PRODUCT SUPPORT

PROBLEM: ECO M8554-0004 changed the four 8838 transceivers to DEC 8641 transceivers at locations E1, E9, E19 and E27. The module revision was changed from D to E.

The 8641's have proved more sensitive to Unibus reflections and spikes and thus are very configuration dependent and sensitive to the additional loads encountered on a 20 Unibus.

The Rev E module is not shipped in new systems and is not being currently manufactured, however, some did find their way into F/S spares before the problem was recognized.

ACTION: If you have a Rev E module order a Rev D. Don't wait until you need the spare.

IS YOUR PROBE TIPPED?

BY: NIGEL WEBB/PRODUCT SUPPORT

A good scope probe tip for use on KL10 backplane pins is obtainable from Hewlett Packard. The Hewlett Packard part number is 8120-1750; description "Tip Probe".

NOT ENOUGH CORE

BY: DON DOSSA/NIGEL WEBB
HOSS/PRODUCT SUPPORT

Several KL10 sites have reported problems while attempting to boot the system using RSX20F. They have reported that BOOTS types the message "NOT ENOUGH CORE". This typically occurs after diagnostics have been run or after the system has been powered up. The usual cause is that the section number field of the PC contains a non-zero value. The non-zero section number causes BOOTS to receive NXM's when it is referencing memory.

There are currently two known ways to solve this problem. The first way is to run KLDCP under RSX10F and perform a function write 76 with bit 24 on. Another way to clear the section number field is to reboot the system and ask RSX20F to verify the microcode. Version 157 of the microcode will clear the section number on initialization.

GOIN' FICHEN'

BY: JEFF GARDINER
F/S WALTHAM

If you're looking for diagnostic listings in the fiche file by hardware revision, forget it! The headers on the fiche read DGKAA-H or DGKAG-I, not Rev 8 or 9. There is a way to quickly locate the correct diagnostic for your machine. The letter H or I indicates the revision. It uses the full alphabet so don't drop your G's or I's. Rev 8 = H and Rev 9 = I. If you still have doubts look at the listing and look for the last entry in the history section. This tells the reason for the current update.

COMPANY CONFIDENTIAL

L A R S ? ?

BY: JOHN SHEBELL

We have been trying to make effective use of LARS data in monitoring the performance of new LCG products. Unfortunately, the number of errors encountered has a significant effect on the value of this data. The purpose of this article is to outline some simple rules which will help improve our lot.

The first problem relates to the SYSTEM TYPE entry. For our purposes, the following list of valid system types applies:

- 1040 - single CPU KA based system.
- 1050 - single CPU KA based system w/swapper.
- 1055 - dual CPU KA based system.
- 1060 - single CPU KI based system.
- 1070 - single CPU KI based system w/swapper.
- 1077 - dual CPU KI based system.
- 1080 - single CPU KL based DecSystem 10 without internal channels.
- 1088 - dual CPU KL based DecSystem 10 without internal channels.
- 1090 - single CPU KL based DecSystem 10 with internal channels.
- 1099 - dual CPU KI based DecSystem 10 with internal channels (on either CPU).
- 2040 - KL based DecSystem 20 without cache.
- 2050 - KL based DecSystem 20 with cache.

At this time, there are no other valid entries for SYSTEM TYPE.

We also find that the SYSTEM SERIAL NUMBER field is also frequently misused. Please ensure that the system serial number entered is identical to the CPU serial number (for single CPU systems); or identical to the lowest serial numbered CPU for multi-CPU systems. Do not enter multiple serial numbers (e.g.: 516/528), since it makes data retrieval very difficult.

The vast majority of errors occur in the DEC option field. These errors generally fall into two-classes--miscoding of KL10 mainframes and options, and midcoding of electro-mechanical peripherals. These are addressed below:

KL10 Mainframes and Options

Service activities on all KL based mainframes should be properly coded. This is not all that easy since each mainframe also contains some "internal" options. The following guidelines are an attempt to keep things simple.

1. With the exceptions listed in item 2, all service efforts on KL mainframes should be coded, as follows:

- KL10-AA - 60 HZ, model "A", 1080 mainframe
- KL10-AB - 50 HZ, model "A", 1080 mainframe

COMPANY CONFIDENTIAL

L A R S ? ? (cont.)

- KL10-BA - 60 HZ, model "A", 1090 mainframe
- KL10-BB - 50 HZ, model "A", 1090 mainframe

- KL10-CA - 60 HZ, model "A", 2040/2050 mainframe
- KL10-CB - 50 HZ, model "A", 2040/2050 mainframe

- KL10-DA - 60 HZ, model "B", 1090 mainframe
- KL10-DB - 50 HZ, model "B", 1090 mainframe

- KL10-EA - 60 HZ, model "B", 2040/2050 mainframe
- KL10-EB - 50 HZ, model "B", 2040/2050 mainframe

2. The following "internal" options should be coded as separate options:

- MA20
- MB20
- and any future internal memory
- RH20
- DIA2Ø
- DTE2Ø
- DMA2Ø
- LP20
- CD2Ø
- DC2Ø

3. There is not, and never has been a KL2Ø.

Electro-Mechanical Options

It's been almost impossible to gather data in new peripheral products. When it says "LP10" does it mean LP10-A or LP10-F; CP10 or CP10-D? There's not much we can do about the confusion inherent in our option designation scheme. In any case, please use the complete option designation contained on the DEC serial number tag. For example, LP10-FA instead of LP10, CR10-DA instead of CR10.

Please.....

Lastly, please ensure that the MODULE/FAIL AREA/FCO field is filled out for every entry. Include module or subassembly part numbers; say "PM" if that's what you did; indicate what adjustment was made; say "not found" if that's what happened. There are sixteen spaces in this entry. It's amazing how much can be said in this space if you care.

We do!!!!

COMPANY CONFIDENTIAL

TO LED OR NOT TO LED

BY: JOHN SHEBELL

At long last we've found a plug compatible LED indicator with sufficient light output to be used as a substitute for the Oshino lamps used in most "traditional" LCG options. These LED's have been evaluated both in-house and at a couple of test sites. Reliability has been super!!! In order to assure effective utilization please read the following application notes:

1. They are relatively expensive (around \$1.25 ea.), so are only cost effective (in terms of replacement labor savings when compared with the old lamp) when used in older LCG options which have the fixed-mount bezels and no "lamp test" feature. In any case, they should not be used in any options which will be scrapped or traded-in in less than 18-mos. unless you can salvage them and put them to use elsewhere.
2. The light output, while acceptable in all currently tested environments is definitely less than the old lamp. Also, the yellow is dimmer than the red. So please try a few first to assure acceptability, red is preferable but the customer may not like the color. Note that colors can be mixed, if desired, to enable data lights to be yellow and status lights to be red.
3. LED's have polarity. Note that installing them "backwards" does not harm, they just don't light. Aside from this they are fully plug compatible and require no hardware modifications.

The Field Service Stockroom will have sufficient quantities to fill "sample" orders of up to 100-units from each Branch currently servicing

DecSystem 10's. After you've tried them please Line Item Forecast your gross requirements. Volume orders will be placed with our vendor once LIF data starts to accumulate.

The part numbers are:

RED 11-14103-00

YELLOW 11-14103-01

Please call LCG Product/Market Support at ext. 6405 in Marlboro, if you should have any questions.

TOPS-10 INFORMATION

BY: DINO GENOVA

SBØ stop codes, save the ERA, APR and SBus diag functions at locations:

.CO???, .COAEF, .COSBO+1 and
COSB1+1

Respectively--these are accessible by running FILDDT on the dump taken of the previous crash.

DN2Ø MODEM REQUIREMENTS

BY: BILL HILLIARD

A Tech Tip will soon be released (DN2Ø-TT-1) which will contain modem requirements for the DN2Ø series hardware. Included will be the modem requirements and recommended customer options.

MA/MB20 CONTROLLERS

BY: SULTAN ZIA

Even the smallest chunk of memory requires the presence of two controllers (modules) even though only one of the controllers might have any memory with it. It is inherent in the logic design of the memory that it operate with two controllers or multiples of there of.

The MA/MB20 print set does indicate this requirement.

COMPANY CONFIDENTIAL
KLDCP EM COMMAND PROBLEM
BY: BILL HILLIARD

When examining a range of PDP-10 addresses via the KLDCP EM command, you will get strange results if the range of addresses crosses a 64K boundary (i.e.: bit 19 incremented). The following example of CTY conversation attempts to illustrate the point:

```
>EM 177777,200000 ;return data from 177777 and
177777/Data      000000 (AC0). Bit 19
000000/Data      not incremented.
>EM 277777,300000 ;O.K. Bit 19 already set
277777/Data      in starting address.
300000/Data
>EM 377777,400000 ;Bit 19 set in starting
377777/Data      address but not
200000/Data      incremented.
>EM 477777,500000 ;O.K.
477777/Data
500000/Data
>EM 577777,600000 ;Bit 19 not incremented
577777/Data
400000/Data
>EM 677777,700000 ;O.K.
677777/Data
700000/Data
```

The problem stems from the fact the PDP-11 is only a 16-bit machine.

CACHE RAM BANGER DIAGNOSTIC HALTS
BY: BILL HILLIARD

When running B.CMD (or BB.CMD) on KL10's without cache, the command string will error-halt in DGMCB (or DHMCB) due to a diagnostic problem. You can continue the command string from the error halt by doing a "JC" command to KLDCP or you can install the following patch to ensure the diagnostic makes a normal exit for a cacheless machine:

	<u>LOCATION</u>	<u>WAS</u>	<u>SHOULD BE</u>
DGMCB	15710	104002	104062
DHMCB	15746	104002	104062

This problem was first seen when Rev 10 was released (first time cache ram banger incorporated in command string) and should be corrected in later revisions.

COMPANY CONFIDENTIAL

WHICH VERSION 157 IS "YOUR" VERSION
157 MICROCODE?

BY: BILL HILLIARD

Determining what microcode is loaded in the KL1Ø CRAM can be a problem is all you know is the version number. There are four different versions of microcode which have a version number of 157. They are distinguished by their name and functionality. Also, two of the four versions appear in two different file formats (one format for RSX2Ø-F, one format for KLDCP). Therefore, you will need to know about six different file names.

UA.MCB - is TOPS-1Ø operating system microcode for model A machines. (RSX2Ø-F compatible file format).

U.RAM - is functional diagnostic (Macro-1Ø instructions) microcode for model A machines. (KLDCP compatible file format).

"In terms of "ones and zeros" loaded in the CRAM, UA.MCB and U.RAM are exactly the same microcode."

UB.MCB - is TOPS-1Ø operating system microcode for model B machines (RSX2Ø-F compatible file format).

UB.RAM - is functional diagnostic microcode for model B machines. (KLDCP compatible file format).

"In terms of "ones and zeros" loaded in the CRAM, UB.MCB and UB.RAM are exactly the same microcode."

KLA.MCB - is TOPS-2Ø operating system microcode for model A machines. (RSX2Ø-F compatible file format).

KLX.MCB - is TOPS-2Ø operating system microcode for model B machines. (RSX2Ø-F compatible file format).

"There is no diagnostic equivalent to TOPS-2Ø operating system microcode. The functional diagnostics will not run with TOPS-2Ø microcode and there are no plans at this time to develop a diagnostic which utilizes the features of TOPS-2Ø microcode (e.g.: KL1Ø paging)."

You will find microfiche listings with the following headings for version 157 microcode:

UA.(V157) for UA.MCB and U.RAM
UB.(V157) for UB.MCB and UB.RAM
KLA.(V157)for KLA.MCB
KLX.(V157)for KLX.MCB

Good Hunting!!!

(NOTE: This information is also contained in a Tech Tip KL1Ø-TT-32).

MORE 6.03 BUGS

BY: LOU NAY

A bug has been found in TOPS-1Ø 6.03 which supplies incorrect SYSERR values for "Bad Data Word" for ARX parity errors. The fix is MCO #7443--in KLSER at PRTRP + 26--should be:

```
PXCT PX.MEM, MOVE T3, (T3)
PXCT PX, MEM, MOVE T3, Ø
```

This patch should be made at any KL site experiencing ARX parity errors and will be in 6.03 A.

COMPANY CONFIDENTIAL

KL10 BACKPLANE TIP

BY: MIKE FLYNN

There are many modules in the KL10 that have inputs which come from nowhere and outputs that go nowhere. I would like to try and explain what you might see while scoping a KL10 backplane.

PIN-----PIN-----PIN
(TRN) (REC) (TER)
TRANSMITTER RECEIVER TERMINATOR
RECEIVER

Consider this to be a typical run with three pins. I will give the static voltage for each pin with the following situations.

SITUATION	(TRN)	(REC)	(TER)
TRN PIN IS OPEN	-2V	-2V	-2V
REC PIN IS OPEN	NORMAL	LOGIC	LEVELS
TER PIN IS OPEN	0V	0V	0V
TRN TO REC IS OPEN	0V	-2V	-2V
REC TO TER IS OPEN	0V	0V	-2V

Signal runs that are open, are relatively easy to find. The runs that are shorted to other runs, to ground, and to power, are the killers. Here are some tips for those.

- If two signals are shorted together, the resistance will be about 34 OHMS to -2V (with power off).
- If a signal run is shorted to ground, you should see ground.
- If a signal run is shorted to power, you should see that power.
- Be careful with shorts, because they are usually not zero resistance shorts, this may produce very strange voltage levels.

COMPANY CONFIDENTIAL

GOT CLOCK PROBLEMS??

BY: Stuart Kennedy

When troubleshooting clock problems, be aware of the following:

1. On the clock 1 print pins FU2 and FT2 will not have any clock signals as you might expect. Neither pin is connected to anything on the backplane nor are the signals terminated on the board. Both points will be at 0V.
2. The signal "synchronize clock H" pin FM2 is not generated from another board. It is merely a means whereby the internal KL clocks can be synchronized to an external device. Unlike the above, this signal is terminated on the clock board and it will always be an ECL low. (i.e.: False).
3. The signal "clock 10/11 clock H" pin FJ2 is the clock signal for the DTE. This signal if present insures the oscillator itself on the clock board is working. This signal should be present anytime power is on irrespective of any clock selection as to rate source, run single step, etc.

DX10 MICROCODE AGAIN

BY: LARRY BURKE

6.03 monitor allows the DX10 to handle data error recovery. Version 14 and later versions of DX10 microcode contain the code to do this also. Unfortunately, any version of this microcode prior to Version 13 may do it wrong. Version 13 also fixes all known problems with TX03 feature (dual port option).

You may order this from SDC as MainDec 10 - DXMPA-M.

845 POWER CONTROL ECO

ECO 12 - MANDATORY ECO

BY: WALT PETROSKI

Recently, we have noticed a problem on machines being returned from the Field which utilize the 845 power controller. In some cases, the 845 was missing ECO #12. This was a mandatory ECO which should have been installed a long time ago. The problem was that the 845 power controller did not meet requirements for UL listing. Please check all equipment which uses the 845 to ensure that ECO #12 is installed.

THE HALT LOOP

BY: MIKE FLYNN

The KL10 micro-code has two locations that it toggles between when it is stopped. These locations are called the halt loop. The halt loop has always been at locations 50 and 53. This tidbit is to let you know that the halt loop will no longer be frozen at locations 50 and 53. The halt loop from now on could be anywhere depending on--1) The version of the micro-code, and 2) the type of hardware you have (20's, 10's, model A, model B). The first version of micro-code that has its halt loop changed, is version 157. In the later versions of the micro-code the halt loop locations are described in the "micro-code description". This is located in the front of the pertinent micro-code listing.

COMPANY CONFIDENTIAL

CNTL-S PROBLEM ON DC2Ø USER LINES (DH11)

BY: BILL HILLIARD

INCOMPLETE INFORMATION FROM AN ISSUE 2 ARTICLE

BY: BILL HILLIARD

A problem has been seen in the Field where a user who types CNTL-S, may sometimes get random garbage characters printed on his terminal. This stems from a RAM chip failure on the M7278 module in the DH11. System software sets the byte count register to zero for the NPR transfer and the register should be decremented after the transfer. However, the register is sometimes decremented before the transfer so the byte count is then -1. When this happens, the user may get line printer buffers, other line buffers, or most anything for PDP-11 memory. The fix is to replace the M7278 module or the following chips on that module:

E31 through E34 (the byte count register)

INTEL 7489

or

INTEL 31Ø1A (early DH11's)

The problem hasn't shown up before because RSX2Ø-F is the first software to use the NPR feature in the DH11. (NOTE: this information can also be found in DC2Ø-TT-1. It is repeated here for exposure).

NOTE: 1. There is no particular revision M7278 module which corrected the problem. Therefore, the same rev board or any board which meets the revision requirements set forth in print set KL1Ø-C Vol. I is acceptable.

2. If you are replacing the chips, use INTEL 7489. There is no known range of date codes for the bad chips.

In an earlier issue of GOOD STUFF (issue 2), I wrote an article containing a TOPS-2Ø patch which solved a problem relating to the magtape subsystem entitled--"Can't talk to your magtapes on DecSystem 20's?" I neglected to specify this patch as a release 1B patch. Some people have been looking for the same "patch" in TOPS-2Ø release 2. You won't find it! Please be aware that information in GOOD STUFF articles attempt to relate current solutions to current problems.

Sorry for the confusion.

COMPANY CONFIDENTIAL

DEC20 FRONT END TROUBLESHOOTING

BY: BILL HILLIARD

In troubleshooting intermittent DEC20 front end problems, it may be to your advantage to prevent TOPS-20 (i.e.: the KL10) from re-loading a crashed -11. For this purpose, there is a debug switch in the monitor (TOPS-20 monitor) which can be set using EDDT. The switch is "FEDBSW." It will normally be zero. Set it to minus one (-1) to prevent front end reloads.

The procedure is as follows at monitor start-up:

1. Get to boot via KLI
KLI> Load -10 bootstrap?
KLI> Yes
 Bootstrap loaded and started
BOOT>
2. Type /L to boot> to load monitor
BOOT> /L
BOOT>
3. Type/G141 to get to EDDT
BOOT>/G141
EDDT
4. Type FEDBSW/> to open location FEDBSW
EDDT
FEDBSW/0
5. Type -1 (CR) to set the switch and close the location. ↵
FEDBSW/0 -1
6. Type 147 \$ G to continue normal monitor start-up ↵
FEDBSW/0 -1
147 \$ G
[PS Mounted]

At the time of a front end crash, the system will now stop and you may begin examing the crashed front end. (i.e.: examine the stack, scope the unibus, whatever).

digital

Good Stuff

COMPANY CONFIDENTIAL

ISSUE NO. 4

This document contains sensitive information which shall not be disclosed to personnel outside of Digital Equipment Corporation.

This Newsletter is meant as an information document. It's contents are not necessarily Company Policy. It's a means by which LCG Product Support can distribute some tidbits of information to you.

TRY AGAIN!!!

We are in the process of updating the distribution list for "Good Stuff". If you have previously requested to be put on the distribution to no avail--try again. If you wish to make an initial request for distribution, please TWX or send a memo to: Nancie Mitchell MR1-1/S35 with the following information: NAME, BADGE #, C.C., LOCATION CODE. (We MUST have all of the above data in order to enter your name). Thanks!!!

FCO CONTROL
BY: NICK LOMBARDO

We are currently in the process of implementing an FCO Control System. This system will be initially installed in the Central Region on a pilot basis. When it is operationally sound it will be installed in the other Regions.

The system is driven by a centralized data base of all installed equipment. Once an FCO is issued, the data base will be updated to show this FCO as being outstanding for all of the affected products. The Regional FCO Coordinator will then make arrangements with the

Branch to have the FCO kit sent to the site and installed. The fact that the FCO has been installed will be captured via LARS (Labor Activity Reporting System). If the installation of the FCO is correctly reported on the LARS form, then there will be no additional paper work to be completed.

This process is rather straight forward and uncomplicated but the initial data capture and startup requires a considerable effort. Before this system can be implemented, the current FCO status of each machine must be determined. We have started to capture this data for current and future shipments, so that the startup effort consists of determining the status of the existing installed base. Each FCO Coordinator has the responsibility for obtaining the data for his Region and may be calling you for this kind of information; if he does, your assistance will be greatly appreciated.

If you have any questions, please feel free to call me at ext. 6824, in Marlboro.

COMPANY CONFIDENTIAL

LCG CORPORATE FIELD QUALITY ASSURANCE GROUP

BY: GRAHAM MORLAND

Band Leader: Art O'Donnell
Musicians: Graham Morland
Herman Millet
Nancie Mitchell

To orchestrate all quality issues when you are a one-man band is never easy and sometimes impossible. Art has accomplished this for the first half of FY78. However, once you pick up the quality baton you are expected to harmoniously resolve all the issues. To achieve this goal, Art has recruited three "fiddlers" to help him call the tune. They all have extensive Field experience which will be a valuable asset in accomplishing their specific charters.

However, let's begin with Art's job specification:

1. Single point focus for all LCG Quality issues to:
 - a. Manufacturing
 - b. Engineering
 - c. Order Processing
 - d. Product Lines
 - e. Shipping
 - f. Logistics
2. Provide Field feedback to responsible groups for action.
3. Inform Field of current procedures.
4. Monitor all Field requests for action to appropriate groups.
5. Coordinate inter-group activities that impact the Field.

For Art to be effective in all these areas, he has the above people heading up specific functions as follows:

Editor . . . William Fischer Assoc. Editor. Nancie Mitchell Editorial Office. . .MR1-1/S35 <hr/> GOODSTUFF will be published on a monthly basis.

Graham Morland - Installation Coordinator

Graham's specific areas of responsibility are:

1. Develop, review, improve all Field Installation Procedures.
2. Do all FCS (First Customer Ship) installation to ensure adequacy of documentation and materials.
3. Develop and maintain all site prep information.
4. Become LCG Environmental Rep.
5. Monitor all system installations and provide monthly data roll-up.
6. Conduct Installation Quality Audits.

Herman Millet - ECO/FCO Coordinator

Herman's specific areas of responsibility are:

1. Review all ECO's STD 100.
2. Generate appropriate FCO/Cost Analysis/Implementation Plans.
3. Coordinate and monitor FCO release cycle.
4. Monitor Field FCO activity.
5. Develop and improve FCO procedures.
6. Develop LCG FCO data base.
7. Maintain LCG Rev. Documentation.

Nancie Mitchell - Information Coordinator

Nancie's specific area's of responsibility encompasses the editorial, artistic representation, review and publishing of the following Field material:

1. Tech Tips
2. Good Stuff
3. Just Stuff
4. MOF Review.
5. System Notification
6. TWX's

COMPANY CONFIDENTIAL

NEW TTY LINE NUMBER ASSIGNMENTS

BY: ARNOLD MILLER

The TOPS 20 release 3 front-end has added support for four special lines. These lines are--the DL11E KLINIK CTY, and three DL11W CTY devices that are connected to the three DN20 front-ends. All installations will have this support whether or not the devices are actually present on the hardware.

The four new lines occupy line numbers 1 through 4 inclusive within the "data line scanner" pseudo-device of the front-end. Therefore, the new device assignments for the DLS are:

```
0 DL11C CTY
1 DL11E KLINIK CTY
2 DL11W line to DN20 #1
3 DL11W line to DN20 #2
4 DL11W line to DN20 #3
5 DH11 #0 line 0
```

As can be seen, the DH11 lines have been translated up from their previous assignments beginning at line #1.

The TOPS-20 monitor has been modified to insure that the correspondence between time-sharing line numbers and DH11 lines is preserved. This has been done by mapping the line numbers that the front-end provides into the old line assignments. Therefore, the time-sharing user will continue to see the following correspondence:

```
0 DL11C CTY
1 DH11 #0 line 0
```

The new lines representing the KLINIK CTY and the three DL11W links have been assigned to the highest available time-sharing line numbers. Therefore, if a system is configured for 96 DH11 lines, then the following correspondence will hold:

```
0 DL11C CTY
1 DH11 #0 line 0
```

```
140 DH11 5 line 15
141 DL11E KLINIK CTY
142 DL11W line to DN20 #1
143 DL11W line to DN20 #2
144 DL11W line to DN20 #3
145 The time-sharing CTY
```

This translation is accomplished entirely within TOPS-20 and has no effect on the internal assignment within RSX20F.

This scheme has one serious drawback. The internal line numbers of the three DL11W lines change as the monitor configuration changes. That is, if one rebuilds the monitor and changes the number of DH11 lines in the configuration file, then the internal line numbers of the DL11W lines will change.

In order to insure that it is always possible to "know" where the DL11W lines are, the monitor performs the following functions at system start-up:

1. Sets all three DL11W lines to "REFUSE SYSTEM MESSAGES".
2. Sets all three DL11W lines to "ignore input". This new line state means that any input from the line is ignored unless the line is assigned to a program.
3. Defines the three system logical names DL1, DL2, and DL3 to be the three DL11W lines for DN20 1,2, and 3 respectively.

This puts the three DL11W lines in the proper state and allows them to be readily identified either for maintenance or for programming.

COMPANY CONFIDENTIAL

LCG TRAINING COORDINATOR

BY: JOHN SWAN

Since April 1st 1977 my chief responsibility in the Corporate Support Group in Marlboro has been to coordinate training and LCG Field Service. In order to make a success of this, I need the assistance of everyone in the Field.

I would like to hear from Engineers who were in Training within the last year. Send me your matured thoughts on the training which you received--did you leave Marlboro with the right skills to do the job?

We are putting together an LCG System Introduction Course which will combine all KL-based system training into a course lasting 8-weeks. This will be supplemented by specialist training. We also hope to have a Field Service software course available this year.

For those of you who are coming to Marlboro, I am in the Field Service Product Support area on the first floor, just before Educational Services. Drop by for a chat or call me on ext. 5504.

M8554 REV E MODULES

BY: LOU NAY

Problem: ECO M8554-0004 changed the four 3838 transceivers to DEC 8641 transceivers at locations E1, E9, E19, and E27. The module revision was changed from D to E.

The 8641's have proved more sensitive to unibus reflections and spikes and thus are very configuration dependent and sensitive to the additional loads encountered on a 20 unibus.

The Rev E module is not shipped in new systems and is not being

currently manufactured, however, some did find their way into F.S. spares before the problem was recognized.

Action: If you have a Rev E module order a Rev F. Don't wait until you need the spare.

SUPPORT EQUIPMENT

BY: MIKE FLYNN

Because of the number of intermittent problems being encountered by our Regional and Corporate Support people, there are items needed to attack these problems. The following is a list of equipment needed by any Support group, at the site, when they arrive on-site.

1. A Digital voltmeter.
2. An extender module.
3. A calibrated scope with short probes and short grounds.
4. As many spare parts as can be carried to the site.
5. As much software "help" as possible.
 - a. Front end listings
 - b. Monitor listings
 - c. A software person

This equipment should be at the site available for use by the Support person to facilitate expedient repair thereby enabling support to fulfill our customer's expectations according to our abilities.

"WE ARE COMPUTER MECHANICS, WE HAVE THE EXPERTISE, GIVE US THE TOOLS, AND MACHINES WILL BE FIXED!"

IS YOUR P.A. SYSTEM BEING PV'D??

BY: BILL FISCHER

PRODUCT SUPPORT

Before upgrading to a KL model "B" ie. replacing KL10-PA with KL10-PV, you should check the following "E" and "C" bus cables.

CABLE	FROM	TO	
BC11A-2	CPU-ABØ1	RH2Ø-AB37	Should be 2 foot (61cm) between module handles.
BC2ØC-1C	CPU-CDØ1	RH2Ø-CD37	Should be 1 foot 3 inches (38cm) between module handles.
BC2ØC-1C	CPU-EFØ1	RH2Ø-EF37	Should be 1 foot 3 inches (38cm) between module handles.

If the cables are longer than shown above when the PV kit is installed then intermittent problems will occur.

KL10 POWER CONNECTORS

BY: KAREN J. RADTKE

CUSTOMER SPARES

The following parts can be purchased by customers in preparation for the installation of their KL10's unless they elect to have a permanent non-disconnectable wiring scheme. The kits and their contents are listed below:

QTY	PART NUMBER	DESCRIPTION	PRICE	LEAD TIME
1		KL10 Female Power connector kit, wall CONTENTS:		
1	12-12018	Cover	\$ 33.00	A*
1	12-12019	Box	\$ 67.00	A
1	12-12020	Connector	\$240.00	A
1		KL10 Female Power connector kit, pendant CONTENTS:		
1	12-12020	Connector	\$240.00	A

* A = off - the - shelf delivery, 2 - 4 weeks, ARO Maynard.

To obtain these parts, you should place the order through your local DIGITAL Sales Office. The delivery time for the above items is 2 - 4 weeks ARO, Maynard. These products are sold by Customer Spares, P/L 75.

FIELD UPGRADE PROBLEMS

WITH MB20

BY: JOHN ALLEN

L.C.E.G.

Energy Enterprises of Denver recently installed an MB20 64K add on to their 128K MA20 system. Due to complex hardware and software interactions, KLINIT configured the MB20 two-way interleaved at 256K. Most TOPS-20 monitors only are assembled to utilize up to 256K and therefore, the added memory was not utilized.

In order to force the MB20 to be configured below 256K KLINIT had to be forced to one-way interleave the MB20 memory. Since there is no command to tell KLINIT to do this, the only way to achieve one-way interleaving was to put both 32K storage module sets on one of the two controllers (leaving the other controller connected but with no storage modules). This forces KLINIT to one-way interleave the MB20 and KLINIT therefore, locates it starting at 128K according to it's configuration tables. There is another possible configuration which should yield two-way interleave of the MB20 but which I have not had a chance to test. That is to insert the two storage modules in the "SM2" positions of the two controllers. This should result in the configuration of the MA20 four-way interleaved at locations 0 to 128K and the MB20 two-way interleaved at 128K to 192K.

In addition, the MB20 requires new versions of Conex (ver. 0.12), DGKBB (ver. 1.10) and DGKBD (ver. 0.9). These new versions are on the Rev 10 and re-release of the Rev 9B KLAD packs, but not on the earlier KLAD packs. Revision 8 systems can be made to use if the above three diagnostics are changed.

28 AWG TWP WIRE

BY: BILL BUCK

PRODUCT SUPPORT

Field Service Logistics, Stockroom 17, is now stocking 28 AWG TWP wire. This wire is required for all KL CPU back-panel FCO's. The part number for a 500 foot spool of wire is 91-07768-59.

SYSERR FIX FOR KLERR LISTINGS

BY: RAY DRUEKE

M.E.G.

Recently a bug was fixed to correctly list the CRAM LOC in KLERROR listings. It will be included in Version 10 of SYSERR.

The fix is as follows:

In SYSERR.MAC
at LST000 + 4

Move T2,KLEFIL+45

should be

Move T2,KLEFIL+47

LSH T1,5

should be

LSH T1,6

Move T2,KLEFIL+44

should be

Move T2,KLEFIL+46

This edit #525 and could also be inserted in SYSERK.EXE with DDT.

Only one other known problem exists with KLERROR listings. Periodically null (all zero) listings are produced under TOPS-10 only. The symptom is that the following items are zero in the SYSERR listing of KLERROR data:

"Created:" daytime

"File Format Version:"

"Record Length:"

and all register values.

If the file format version is not 1 or record length is not 1000 bytes disregard the entry, it is wrong! The bug is in RSX20 and is under investigation.

If you know of other bugs in SYSERR package please submit of SPR.

TIME TO ADJUST YOUR "CLOCKS"?

BY: PAUL GUGLIELMI

L.C.E.G.

Most modules in the KL10 can be replaced without requiring clock deskew adjustments. However, replacement of the following modules will require the checking and/or readjustment of clocks.

LOGIC ASSY.	MODULE REPLACE	SYSTEM COMPONENT WHICH MUST HAVE ITS CLOCK DESKEWED
CPU BAY	M8526 - CLK CPU Clock Module	DMA2Ø, All MA2Ø's, All MB2Ø's All RH2Ø's
	M8519 - MEM (Slot Ø7) SBus Translator	DMA2Ø, All MA2Ø's, All MB2Ø's
	M8516 - TRN (Slot Ø6) E&C Bus Translator	All RH2Ø's
MA2Ø	M8562 - MA2Ø Timing Module	MA2Ø
	M8561 - MA2Ø Control Module	MA2Ø
	SBus Cable	MA2Ø
DMA2Ø	M8563 - DMC - Adapter Interface DMA2Ø Board Two	DMA2Ø
	M856Ø - DTR - DMA Timing and SBus Transceivers	DMA2Ø
	SBus Cable	MB2Ø
MB2Ø	M8565 - MB2Ø Timing Module	MB2Ø
	M8568 - MB2Ø Control Module	MB2Ø
	SBus Cable	ME2Ø
I/OBAY	M8559 - CDS - I/O Bay Clock Distribution Module	All RH2Ø's
	M8556 - DP - RH2Ø Data Path	RH2Ø

Good Stuff

ISSUE NO. 5

This document contains sensitive information which shall not be disclosed to personnel outside of Digital Equipment Corporation.

This Newsletter is meant as an information document. It's contents are not necessarily Company Policy. It's a means by which LCG Product Support can distribute some tidbits of information to you.

KEEP THOSE ARTICLES COMING IN!

Now that we have committed to a monthly publication of Goodstuff, we are urging strong Field participation. With this total participation we feel Goodstuff will truly be "goodstuff".

If you have an article which you feel should appear in Goodstuff, please forward it to:

Nancie Mitchell
MR1-1/S35

NIV STOP CODE

BY: LARRY BURKE
PRODUCT SUPPORT

A System that repeatedly crashes when booting, or during a power fail restart with NIV stop code probably has corrupted PDP8A memory in the DX10. This is a volatile memory and can be corrupted by a power glitch. If this occurs and you power down the DX10 and leave it down while you boot the system, then power it back up and boot the DX10. Everything should come up okay. If you have a DX10 that does this repeatedly change the M8311 as soon as possible.

BRADY MARKERS

BY: HERMAN MILLET
LCG QUALITY ASSURANCE

Whenever an FCO was written against a module, Brady Markers were needed to indicate that the module had been reworked to the next higher revision level. Too often this very important step of the module rework was difficult to accomplish, because the Brady Marker itself was difficult to obtain. Hopefully, this problem has been solved...Brady Markers are now stocked and have a DEC Part Number assigned. The Part Number is as follows:
90-08356-00 (WIRE IDENTIFIER (A-Z))

LED ORDERS

BY: JOHN SHEBELL
M.E.G.

Order activity for the LED lamp replacements (PN 11-14103-00/01) has increased dramatically over the last six weeks. Since these orders were frequently not preceded by appropriate Line Item Forecasts, stock-outs have been frequent. Please be sure to LIF your requirements prior to placing orders. In the meantime we are increasing our stocks as fast as possible. PLEASE BE PATIENT!

COMPANY CONFIDENTIAL

KEEP ALIVE CEASED
BY: R.J. MALONEY
PRODUCT SUPPORT

LA36 FAILURE AS CTY
ON DEC SYSTEM-20'S
BY: RICK ELLISON

ROCKY MOUNTAIN DIST. SUPPORT

The operating system in the front end (RSX20) has a three sec. timer. The purpose of this timer is to see if the DEC 10 or DEC 20 has modified a memory address (10 or 20 memory). If it has not, it assumes the 10/20 has ceased, hence--Keep Alive Ceased. Several conditions can cause this error message--

- A. If the monitor get's into an instruction loop the address that must be modified will never be addressed.
- B. If the hardware interrupt is asserted and is on a higher priority (lower numerical) and cannot be dismissed the interrupt that services the Keep Alive Ceased will never be processed.

It is important to get a software dump to help in understanding what caused the KAC and lead into a software or hardware correction.

If your LA36 console on a DEC System-20 dies and you want to replace it, you may encounter a problem: The CTY is 20ma; all other communications are EIA--hence, no go for swapping another terminal from customer system into place. The following may help out:

All LA36's (even EIA flavors) start out as 20ma. All that is needed is to remove the EIA mate-n-lok and plug in the 20ma mate-n-lok on the control board on the back door of an EIA LA36 (assuming customer has one).

NOTE: In case you don't know--the EIA mate-n-lok is on the lower left hand side (as you bend over the keyboard and look down onto the open back door of the LA36). The 20ma mate-n-lok is on the lower right hand side of the board. Both cannot be plugged in at the same time you want it to work.

Another alternative could be (in Version 3 of TOPS 20) to use a dial-up terminal on the KLINIK line with KLINIK in "REMOTE" mode.

<p>EDITOR WILLIAM FISCHER</p> <p>ASSOC. EDITOR. . NANCIE MITCHELL</p> <p>EDITORIAL OFFICE MR1-1/S35</p> <p>GOODSTUFF will be published on a monthly-basis.</p>

COMPANY CONFIDENTIAL

RH20-TM02/TM03-TU16/TE16/TU45
MAGTAPE BASIC DIAGNOSTIC "DFTUE" VER 5.0
 BY: ED MALONE
 PRODUCT SUPPORT

PROBLEM: Several magtape timing tests in the "DFTUE" Ver 5.0 diagnostic fail when cache is on the following:
 (TST 104, 136, 137 & 140)

SOLUTION: Inhibit cache prior to running the basic diagnostic. (This is a temporary fix).

CHANGE LOCATION	FROM	TO
137	0,,5	1,,5
30623	402000,,62603	254000,,104661
104661	Ø	402000,,62603
104662	Ø	476000,,30506
104663	Ø	254000,,30624
30056	-1	Ø

TM02 - 8901 YC REV J
 BY: DON WERTH
 PRODUCT SUPPORT

1. A REV J in Slot #3 will cause DFTUE VER 4 TST #162 to fail.
2. ***TST 162; TM02/TU45 0/0; ERR PC=40241 : MAINT MODE -
 Incorrect
 Preamble PE
 DRER BITS WRONG
 GOOD: 000300 BAD: 000100 XOR: 000200
 MAINT MODE FOR ABOVE WAS: 27

3. The Patch to circumvent this is:

LOC	FROM	TO
137	Ø,,4	1,,4
4Ø211	6Ø664Ø,,17	332ØØØ,,15
4Ø226	2ØØ34Ø,,754Ø7	2Ø134Ø,,2ØØ

4. NOTE: REV J is acceptable in Slots 1/2.
5. This patch will be incorporated on the next Diagnostic Release.

COMPANY CONFIDENTIAL

FOR YOUR INFORMATION

BY: R.J. MALONEY
PRODUCT SUPPORT

DX10 MICROCODE

BY: LARRY BURKE
PRODUCT SUPPORT

An article appeared in Goodstuff - Issue 3 - Page 2 regarding 6.03 Bug, written by Ray Druke. The article stated the following:

A bug has been found in TOPS10 6.03 which supplies incorrect SYSERR values for "BAD DATA WORD" for ARX parity errors. The fix is MCO #7443.

In KLSER at
PRTRP+26
PXCT PX.MEM, [Move T3, (T3)]
 should be
PXCT PX.MEM, [Move T3, 0]

It also stated:
This patch should be made at any KL site experiencing ARX parity errors and will be in 6.03A.

There was an error in last months Goodstuff. It said there are known problems with version 14 of the DX10 microcode and that version 13 fixes these problems. It should have read that there are problems with version 4 not 14. There has since been an enhancement put in 13 making it 14. 14 is the latest, greatest and contains no known problems, it is also the only available version. Any sites who have received 603 monitor are being sent a copy of the DX10 Microcode Ver. 14 from Software Distribution. If you have a customer who needs Ver. 14 and had not received it by the time you receive this edition of Goodstuff, notify the Software Distribution Center.

PLEASE NOTE: The patch for "BAD DATA WORD" is in error--please disregard this article!!!

RUNNING DDQCB
BY: DINO GENOVA
PRODUCT SUPPORT

The minimum acceptable DX10 microcode versions that should be running anywhere is Ver. 6 with all monitors prior to 603, and Ver. 14 with 603 monitor or any site with a TX03 switch option in either a TX01 or TX02. Optionally, Ver. 14 can be used with all monitors.

There is a problem running DDQCB Ver. 0.6 on RH20 #5. If you select this controller along with any other devices the diagnostic has a page fail trap error. The following patch is required to run this diagnostic:

EM51564
51564/254500 051551

DM51564/254520 051551

NOTE: Diag. Engineering has been informed and the problem will be corrected in Ver. 0.7 Release.

COMPANY CONFIDENTIAL

TX01 SPARES

BY: LARRY BURKE
PRODUCT SUPPORT

STC VS. DEC PART NUMBERS

BY: LARRY BURKE
PRODUCT SUPPORT

Most TX01 spares boards are not on site, they are in a "hero" kit kept in the Regional Logistics Stockroom. If you suspect that you have a TX01 problem send for this kit immediately. Then troubleshoot while this kit is en route. There have been recent incidents where hours and even days have been spent isolating the problem to a module, or just to one of a group of modules then ordering the module or modules. If you attempt to obtain a kit and encounter difficulty contact the Technical Assistance Center at 617-481-9511, ext. 6903, for assistance.

STC changes the part number of modules with each phased in ECO to the module. (Refer to STC part number compatibility list for example). We do not change the DEC 29 class number in this case. The only time the 29 class number for a particular module will change is if STC changes a module to a revision which can be used in either a TX01 or a TX02. In this case Logistics obsoletes both the part number for the TX01 only module and the TX02 only module and replaces them both with a part number for the new module. The old numbers are not discarded so that any order received for either obsolete number will be filled by the new number. There is a cross-reference file on microfiche that covers TU70/TX01 parts. It is obsolete as far as STC part numbers are concerned, but it will get you the correct DEC part number if you know either the module type, or its location. Both the cross-reference file and the part number compatibility list are on red top microfiche with vendor manuals. No TU72/TX02 parts are on the cross-reference yet.

NEW PROGRAM:

MEMCON - KL10 MEMORY CONFIGURATOR
BY: JEFFREY ARNO BARRY

CONEX is being replaced by MEMCON. The internal channel functions of CONEX have been moved to TRACON, therefore MEMCON is used only for configuring memory and other related functions.

Some old CONEX bugs have been fixed in MEMCON. In particular-- the program now properly determines KL model which means that external memory sizing works properly. Also, the list of configuration rules has been rearranged so that the most constrained rules are tried first. This means that mixed MA20/MB20 configurations are less likely to cause "gaps" in the memory space.

MEMCON has been submitted for release and should reach the Field eventually. The listing will be in the fiche under DGQFB.

COMPANY CONFIDENTIAL

BACKUP AND DUMPER ERROR RECOVERY

BY: LARRY BURKE/BILL FISCHER
PRODUCT SUPPORT

Until 6.03 monitor was released backup was unable to inhibit, "monitor write error recovery." This was fixed by 6.03 monitor but introduced the appearance of another problem. This apparent problem is, that write errors have occurred and that they have not been recovered from. What happens is that when any program sets the bit to inhibit monitor error recovery, and an error occurs, the monitor logs the error in SYSERR as unrecoverable, and then reports the error back to the program.

Backup and early versions of dumper output a message to the user similar to "...hardware parity error writing file-----", then all versions simply output the record that had the error again with the same sequence number. Some versions of dumper output a message "writing duplicate record" but backup gives no message at this time, and neither outputs a message indicating successful recovery.

The reasons for these programs inhibiting monitor error recovery, and recovering by writing a duplicate record are safety and speed. Backspacing, then erasing the bad record could leave a portion of this record not completely erased when using some of our older tape equipment if it was not perfectly aligned. If this happens the residual noise block will cause problems trying to read this tape. It is also faster to keep tape moving forward.

Some things to watch for to determine if you have an equipment problem are:

ooSYSERR record of "unrecoverable" write errors with no retry count.

ooSYSERR under TOPS-2Ø will output the job that was running.

ooSYSERR under TOPS-1Ø needs a "logical" name assigned to the tape running, to indicate the job that was running.

ooTen (10) to twenty (20) write errors are not unusual per reel of tape.

ooSoftware may report "two copies of sequence number XYE were found" (so what) or "no good copy of sequence number XYE was found" (ouch)!!!

If you are unsure whether or not you might have an equipment problem, do not hesitate to contact the LCG Technical Assistance Center.

COMPANY CONFIDENTIAL

RPØ4/5/6 DIAGNOSTIC FAILURE - FALSE "OPI'S"

BY: DON WERTH
PRODUCT SUPPORT

Many disks seems to be failing test #326 with the following fault--
"OPI' not asserted after 3 index pulses". Also "DTE" is reported
in error register #1. This failure is the result of the way the
diagnostic manipulates the logic to cause an "OPI" and is due to
chip differences between vendors on the dual port module in the
"DCL". A patch is available to modify the test timing by changing
the write header command (MOVEI 1,63) to a write data command
(MOVEI 1,61) in the following:

<u>NAME</u>	<u>VERSION</u>	<u>LOCATION</u>
DDRPH-A	Ø.1	47363
DDRPH-B	Ø.2	47406
DFRPH-A	Ø.1	47366
DFRPH-B	Ø.2	47423 47411
DDRPK-A	Ø.1	47216
DDRPK-B	Ø.2	47216
DFRPK-A	Ø.1	47374
DFRPK-B	Ø.2	47221
DDRPJ	Ø.1	47217
DFRPJ	Ø.1	47222

of Good Stuff!!

NOTE: This is a diagnostic failure only!!! Normal operation
(monitor) cannot produce this error.

SOMETHING TO MAKE REFERENCING EASIER!

BY: NANCIE MITCHELL

In an effort to simplify referencing GOODSTUFF articles we have
devised the following index method:

- On the final page of each issue of GOODSTUFF you will find an index of article titles (only) for that particular issue.
- On the final page of the quarter-end issue of GOODSTUFF you will find an index of article titles for each issue of GOODSTUFF printed in that particular quarter.

and...as you might have guessed--

- On the final page of the year-end issue of GOODSTUFF, you will find an index of all articles published in GOODSTUFF for the entire fiscal year.

Hopefully, with the implementation of this index it will make all
of your lives a little easier when trying to locate a single article.
(INDEX ON NEXT PAGE)

COMPANY CONFIDENTIAL

GOOD STUFF INDEX

(THIRD QTR. - FY 78)

ISSUE NO. 4

- FCO CONTROL
- LCG CORPORATE FIELD QUALITY ASSURANCE GROUP
- NEW TTY LINE NUMBER ASSIGNMENTS
- LCG TRAINING COORDINATOR
- M8554 REV E MODULES
- SUPPORT EQUIPMENT
- L A R S ? ?
- TO LED OR NOT TO LED
- TOPS-10 INFORMATION
- DN2Ø MODEM REQUIREMENTS
- MA/MB20 CONTROLLERS
- KLDPC EM COMMAND PROBLEM
- CACHE RAM BANGER DIAGNOSTIC HALTS
- WHICH VERSION 157 IS "YOUR" VERSION 157 MICROCODE?
- MORE 6.03 BUGS
- KL10 BACKPLANE TIP
- GOT CLOCK PROBLEMS??
- 845 POWER CONTROL ECO - ECO 12 - MANDATORY ECO
- THE HALT LOOP
- CNTL-S PROBLEM ON DC2Ø USER LINES (DH11)
- INCOMPLETE INFORMATION FROM AN ISSUE 2 ARTICLE
- DEC2Ø FRONT END TROUBLESHOOTING
- DX10 MICROCODE AGAIN

ISSUE NO. 5

- NIV STOP CODE
- BRADY MARKERS
- LED ORDERS
- KEEP ALIVE CEASED
- LA36 FAILURE AS CTY ON DEC SYSTEM-20'S
- RH20-TM02/TM03-TU16/TE16/TU45 MAGTAPE BASIC DIAGNOSTIC "DFTUE" VER. 5.0
- TMØ2 - 8901 YC REV J
- FOR YOUR INFORMATION (6.03 BUG)
- RUNNING DDQCB
- DX10 MICROCODE
- TX01 SPARES
- NEW PROGRAM: MEMCON - KL1Ø MEMORY CONFIGURATOR
- STC VS. DEC PART NUMBERS
- BACKUP AND DUMPER ERROR RECOVERY
- RPØ4/5/6 DIAGNOSTIC FAILURE - FALSE "OPI'S"

Good Stuff

ISSUE NO. 6 - APRIL 1978

This document contains sensitive information which shall not be disclosed to personnel outside of Digital Equipment Corporation.

This Newsletter is meant as an information document. It's contents are not necessarily Company Policy. It's a means by which LCG Product Support can distribute some tidbits of information to you.

* * * I M P O R T A N T * * *

DUE TO THE EXTREME SENSITIVITY OF MANY OF THE ARTICLES IN THIS PUBLICATION, WE WOULD LIKE TO STRESS THE FACT THAT "GOODSTUFF" MUST BE TREATED WITH COMPLETE CONFIDENTIALITY.

THIS IS ESPECIALLY TRUE IN CUSTOMER SITUATIONS!

YOUR COOPERATION IN THIS IS IMPERATIVE AND WILL BE GREATLY APPRECIATED.

Mike Flitterman

CHECK YOUR POWER SUPPLIES

BY: DINO GENOVA
PRODUCT SUPPORT

The H744 power supplies are subject to voltage drift. This is especially true when new modules are installed in a subsystem. The low voltage which we have seen put out by these supplies has caused many intermittent failures. These supplies should be checked during PM and periodically during any troubleshooting session.

DMA20 TIMING

BY: MIKE FLYNN
PRODUCT SUPPORT

While troubleshooting a 1080 or 1090 system, diagnostics may fail at clock rates other than "CR0". These failures may be bogus, due to the design intentions of the DMA20. The DMA20 is designed to run diagnostics at "CR1" and "CR2" in ONE BUS MODE only.

COMPANY CONFIDENTIAL

DFRHB A10
BY: ROBERT NOBREGA
I.H.F.S. LCG

I recently discovered a problem with DFRHB A10 version 11. It appears that there is a discrepancy between the microfiche listing and what is actually being distributed to the Field on the klad pack. The problem will only appear on KL10 systems which have more than four RH20's.

The diagnostic will fail during the RH20 initialize routine during test #161. A status error will be reported, which when analyzed will show that the done bit failed to clear. This happens because the channel scanner scans the upper four channels at half the rate of the lower four channels. The software delay to compensate for this action was apparently left out of the diagnostic which was distributed to the Field, but it was included in the microfiche listing.

If this problem occurs, the diagnostic can be patched by using EDDT as follows:

MBINI1+2/	JRST PATCH
PATCH/	CONO 540 5510
PATCH+1/	JSR PATCH+20
PATCH+2/	JRST MBINI1+3
PATCH+20/	0
PATCH+21/	MOVEI 50
PATCH+22/	SOJG PATCH+22
PATCH+23/	JRST@PATCH+20

EDITOR. . . .	William Fischer
ASSOC. EDITOR .	Nancie Mitchell
EDITORIAL OFFICE	MR1-1/S35
GOODSTUFF will be published on a monthly basis.	

AR AND ARX PARITY ERRORS
IN THE KL10
BY: MICHAEL NEWMAN
LCEG

There are two things that hardware engineering supports when a KL10 gets an AR or an ARX parity error.

STATEMENT 1 - KI Paging Microcode (TOPS-10)

At the time of detection of an AR or ARX parity error the microcode is forced to the internal page-fail microcode routine. This routine takes the 36-bit quantity in the AR and stores it in AC block 7 location 0. This routine also takes the 36-bit quantity in the ARX and places it into AC block 7 location 1.

STATEMENT 2 - KL Paging Microcode (TOPS-20)

At the time of detection of an AR or ARX parity error the microcode is forced to the internal page-fail microcode routine. This routine takes the 36-bit bad data word from the AR or the ARX and places it in AC block 7 location 0. Although the AR and the ARX are both stored elsewhere after this hardware engineering will not ensure that these locations remain the same or even that they will be stored at all. KL paging microcode also prevents an incomplete cycle by doing the write cycle of a read pause write. Good parity will be stored in this write cycle.

Both Statement 1 and Statement 2 are true for microcode versions up to and including 203. There are plans afoot to make both of these error logouts the same. The Field will be notified when these changes are made.

Copyright © 1978, Digital Equipment Corporation

COMPANY CONFIDENTIAL

ARE YOU A CLOCK WATCHER?

BY: MIKE FLYNN
PRODUCT SUPPORT

Are you a clock watcher? If not, you should be!

The coax cables on the KL1Ø backplane can go bad. If they do, they can cause very intermittent problems. Other cables can go bad also.

So...check your clocks. Check all your clocks!

THIS IS WHAT YOUR CLOCKS SHOULD LOOK LIKE!

	KL1Ø-PA (MODEL A)		KL1Ø-PV (MODEL B)
MBOX	4Øns		33.3ns
CHANNELS	4Øns		33.3ns
CACHE	4Øns		33.3ns
EBOX	8Øns to 2ØØns	{Micro-Code}	66.6ns to 166.5ns
		{"T" Field}	
DTE	8Øns		66.6ns
EBUS	16Øns		133.2ns
SBUS	16Øns		133.2ns

THIS IS WHERE YOU SHOULD FIND THESE CLOCKS

MBOX

MB12	H	-	4C14R2
MBØ6	H	-	4C15R2
MBØØ	H	-	4C16R2
MBØ	H	-	4C2ØR2
MBX	H	-	4C21R2
MBC	H	-	4C22R2
CSH	H	-	4C23R2
PMA	H	-	4C29R2
PI	H	-	4C31R2
CLK	H	-	4C32R2
MTR	H	-	4C33R2

CHANNELS

CHC	H	-	4CØ9R2
CRC	H	-	4C1ØR2
CCL	H	-	4C11R2
CCW	H	-	4C12R2

CACHE

CHX	H	-	4C28R2
-----	---	---	--------

(cont. next page)

COMPANY CONFIDENTIAL
ARE YOU A CLOCK WATCHER?
 (cont.)

THIS IS WHERE YOU SHOULD FIND THESE CLOCKS

EBOX

APR	H	-	4C34R2
CON	H	-	4C35R2
VMA	H	-	4C38R2
EDP 3Ø	H	-	4C39R2
CRM 16	H	-	4C4ØR2
EDP 24	H	-	4C41R2
CRM 12	H	-	4C42R2
EDP 18	H	-	4C43R2
CRM Ø8	H	-	4C44R2
CRM CRA	H	-	4C45R2
MCL	H	-	4C47R2
IR	H	-	4C48R2
EDP 12	H	-	4C49R2
CRM Ø4	H	-	4C5ØR2
EDP Ø6	H	-	4C51R2
CRM ØØ	H	-	4C52R2
EDP ØØ	H	-	4C53R2
SCD	H	-	4C54R2

DTE

EBUS	1Ø/11	CLK Ø8L	2AØ2F2
EBUS	1Ø/11	CLK Ø9L	2AØ4F2
EBUS	1Ø/11	CLK 1ØL	2AØ7F2
EBUS	1Ø/11	CLK 11L	2AØ9F2

EBUS

RH20:

EBUS	-	CLK ØØL	- 2A36D2
EBUS	-	CLK Ø1L	- 2A33D2
EBUS	-	CLK Ø2L	- 2A3ØD2
EBUS	-	CLK Ø3L	- 2A27D2
EBUS	-	CLK Ø4L	- 2A24D2
EBUS	-	CLK Ø5L	- 2A21D2
EBUS	-	CLK Ø6L	- 2A18D2
EBUS	-	CLK Ø7L	- 2A15D2

DIA2Ø:

EBUS	-	CLK 15L	- 1A15V2
------	---	---------	----------

DIB2Ø:

EBUS	-	CLK 15L	- 1A15V2
------	---	---------	----------

(cont. next page)

COMPANY CONFIDENTIAL
ARE YOU A CLOCK WATCHER?
(cont.)

THIS IS WHERE YOU SHOULD FIND THESE CLOCKS

SBUS

MA2Ø:	SBUS	-	CLK INT L	-	3F54D2
MB2Ø:	SBUS	-	CLK INT L	-	3F54D2
DMA2Ø:	SBUS1	-	CLK EXT L	-	1CØ3P1

NOTE: The part number for the KL1Ø ECL clock coax is:
17-ØØØ39

PM AND PV INSTALLATIONS

BY: LOU NAY
PRODUCT SUPPORT

The kits are shipped at the current manufacturing revision level.
(currently Rev 10)

When installing, or better still, planning an installation be aware that the un-upgraded portion of the M.C. must match the revision level of the PM or PV as must the diagnostics or you're buying trouble with a capital "T".

ARE YOU RUNNING FROM COPS

BY: MIKE FLYNN
PRODUCT SUPPORT

There is a possibility that "CØP" TOPS-1Ø stop-codes on a KL1Ø may be a result of a parity error detected by the AR or ARX during a deposit or examine function. To determine why the page-fail really occurred, look at the page-fail word in AC block 7, location 2, stored for I/O page-fails.

A breakdown of this word can be found on page 33 of the KL1Ø Maintenance Handbook.

AIR FLOW VANE SWITCH ADJUSTMENT

ON KL PROCESSORS

BY: BOB SCOTT
NJ DISTRICT OFFICE

1. Place CPU in override.
2. Check the H770 regulator output for +15VDC and adjust if necessary.
3. Place DVM on yellow wire of any one of the vane switches and monitor this voltage.
4. Disconnect all of the vane switches except for the one being adjusted.
5. Loosen the vane switches and rotate it 30° - 45° in one direction or the other while monitoring the yellow wire voltage. Adjust for highest possible voltage.
6. Do this for each switch, one at a time. If voltage cannot be adjusted to +5VDC, or greater, replace the switch.

COMPANY CONFIDENTIAL

PATCHES TO THE KL-1Ø CPU EBOX DIAGNOSTICS

BY: DALE COOK

LARGE COMPUTER DIAGNOSTICS

The following KL-1Ø EBOX CPU diagnostics have a bug which causes them NOT to run the isolation routines which provide module call out:

DGKAA, Rev 0.1Ø (Part 1 for Model A CPU)
DGKAB, Rev 0.1Ø (Part 2 for Model A CPU)
DHKAA, Rev 0.1 (Part 1 for Model B CPU)
DHKAB, Rev 0.1 (Part 2 for Model B CPU)

The patches are as follows:

DGKAA: location 1576Ø/should be 42446
location 46456/should be 56Ø61

DGKAB: location 1576Ø/should be 43Ø46
location 63674/should be 56Ø61

DHKAA: location 16Ø61/should be 42453
location 53514/should be 31Ø56

DHKAB: location 16Ø16/should be 43Ø47

The first location actually corrects the bug, the second causes the diagnostic to type out a new version number (and is, therefore, required only for documentation sake).

There are two ways to make the patch permanent in the Field: under time-sharing and stand alone. CAUTION: Make sure you know what your doing! If you have never updated a KLAD, more patching information can be found in "KLAD1Ø.MEM" and "KLAD2Ø.MEM". Also, be prepared to create a new KLAD1Ø/2Ø in case of error. These procedures are documented as follows:

*KLAD1Ø - FCO KL1Ø Rev 1Ø
KLAD2Ø - KLAD2Ø.MEM

* = An error exists here - the command to the KLAD1Ø program should be P1Ø1Ø - not P1Ø9Ø)

- 1A) Under TOPS-1Ø timesharing.
 - a) Mount the KLAD pack on any drive and log on as [6,1Ø].
 - b) Use the editor of your choice and edit the "A.11" file for the diagnostic as follows:

(cont. next page)

COMPANY CONFIDENTIAL

PATCHES TO THE KL-1Ø CPU EBOX DIAGNOSTICS

(cont.)

- 1) Go to the end of the file and observe the lines!

```
E ,X@,Oh@
;EOF
```

- 2) Immediately before these lines insert patch lines in this format (this example is for DGKAA, but all work the same):

```
E01,1576Ø,42446
E01,46456,56Ø61
```

Note that the second character is the letter "O" not the digit "Ø".

- c) Restore the new version of the file to disk using KLAD1Ø, as follows:

```
.AS KLAD DEV           ;ASSIGN THE PACK AS "DEV"
.RUN WHEEL             ;SET WHEEL CAPABILITIES
.RUN KLAD1Ø
*/DEV:DEV              ;ASSIGN THE DEVICE
*DGKAA.All[6,1Ø]/Toll ;COPY NEW VERSION TO THE
                       ;ll FILE AREA
CONTROL C              ;DONE!
```

- 1B) Under TOPS2Ø timesharing

The situation is a little more complex here because the changes must be made through the DTE2Ø front-end using RSX2ØF.

- a) First find the diagnostic file on the 1Ø side:

```
@ENA                   ;YOU MUST HAVE PRIV'S
$DIR <*> DGKAA.All     ;DON'T KNOW WHAT DIRECTORY
```

- b) If it is there, edit as above. If not, it must be gotten from the pack as follows:

```
$FE                   ;START THE FE-PROGRAM ON CTY
CTRL \                ;CALL THE PARSER
PAR>RU MOU            ;MOUNT THE FE DEVICE
MOU>FE:
MOU>CTRL Z            ;EXIT
CTRL \                ;PARSER AGAIN
```

COMPANY CONFIDENTIAL

PATCHES TO THE KL-1Ø CPU EBOX DIAGNOSTICS

(cont.)

b) cont.

```
PAR>RU PIP ;START PIP
PIP>FE: [n,m]=DBØ:[6,11] ;COPY TO 1Ø SIDE
DGKAA.All
```

(Note that n,m are the TOPS-1Ø-style PPN of your connected directory...you can get them by running the system CUSP, TRANSL.)

c) Now edit as above and then copy into the 11 area as follows:

```
$FE ;START THE FE AGAIN
CTRL\ ;AND PARSER
PAR>RU PIP ;START PIP
PIP>DBØ:[6,11]*.*=FE: ;COPY NEW VERSION
[n,m]DGKAA.All/NV
```

2) For a KLAD1Ø stand alone system, use KLDCP and the following procedure (again the example is for DGKAA, but all work the same):

```
.RI ;RE-INITIALIZE KLDCP
.ZE 3ØØØ,77776 ;ZERO PDP11 CORE
.RPØ ;SELECT THE RPØ4 WITH KLAD
.P CDUMP.All ;LOAD CORE DUMP PROGRAM INTO CORE
.P DGKAA.All ;NOW BRING THE DIAGNOSTIC INTO
;CORE
.DE 1576Ø/42446 ;PATCH THE DIAGNOSTIC
.DE 46456/56Ø61
;*****
;NOW WRITE ENABLE THE RPØ4/5/6
;*****
.CD FOO.Ø27 3ØØØ,67777 ;CORE DUMP THE PROGRAM YOU JUST
;PATCHED TO AN EMPTY FILE ON THE
;PACK
.RENM DGKAA.All DGKAA.OLD ;RENAME THE OLD VERSION OF THE
;DIAGNOSTIC TO BE SAFE
.RENM FOO.Ø27 DGKAA.All ;RENAME THE FOO FILE TO BE THE
;NEW VERSION OF THE DIAGNOSTIC
```

COMPANY CONFIDENTIAL

PATCHES TO THE KL-1Ø CPU EBOX DIAGNOSTICS

(cont.)

;*****
;WRITE PROTECT THE RPØ4/5/6
;*****

Diagnostics will be issuing an "official" patch soon and the next release of the tests will include the fix. Sorry, fellows, but Murphy gets us all! Oh, yes, I'm also aware (now) that the documentation of these diagnostics leave a lot to be desired; it is much longer than it needs to be and so out of sequence that its value is questionable. I'll make an attempt to get the documentation fixed by the next release also.

CONTROL YOUR MEMORY

BY: R.J. MALONEY
PRODUCT SUPPORT

KL1Ø CARD CAGE
BY: MIKE FLYNN
PRODUCT SUPPORT

There is the possibility that during the insertion of the M8521 into slot 25 or the insertion of the M8514 into slot 27 of the KL1Ø CPU card cage, that the module may actually seat itself into slot 26. There is much to be gained by double-checking these modules after insertions!

This problem and possible solutions are presently being investigated.

If you have added a memory controller with no storage modules plugged in, DGKBB will fail. Future plans for the diagnostic will be to list the configuration, but will not converge on the error since the hardware is functioning correctly. One way to get the string of diagnostics running without interventions is to disconnect the memory by unplugging the SBus cable or use the JC command.

COMPANY CONFIDENTIAL

HOW TO GET A REAL SNAP-SHOT OF A KL10 SYSTEM!

BY: MIKE FLYNN
PRODUCT SUPPORT

In the old days, when a computer system stopped doing its thing, there were lights to look at and buttons to push for the maintenance guy to try and see how bad the situation really was.

Today...no lights and no buttons (KL10)!

The following steps will allow you to examine a KL10-based system's processor, memory and sub-components in a relatively undisturbed state with these considerations.

1. Remember the device that you loaded KLDPC from, because that device and it's controller may be changed.
2. Pushing the load button on the KL, causes a unibus init. (reset) and any device on the unibus may have been reset.

These steps should be used to gather accurate data on systems with intermittent problems.

ALL KL10's

<u>TYPE TO KLDPC</u>	<u>WHERE</u>	<u>WHAT</u>
EE 174434	P. 1-29	;DTE STATUS.
EE 174430	D.T.E.M. P. 1-30	;DTE DIAG 1.
FX0		;TURN OFF CLOCK.
ALL		;LOOK AT REGISTERS.
FR100,177	P.61-84	;GET ALL FUNCTION READS.
FX7		;SET RESET.
PL100		;PULSE CLOCK.
FX6		;CLEAR RESET.
FX1		;TURN ON CLOCK.
FX0		;TURN OFF CLOCK.
EC		;LOOK AT MICRO-CODE ADDRESS. IS THIS THE HALT-LOOP FOR YOUR MICRO-CODE?

COMPANY CONFIDENTIAL

HOW TO GET A REAL SNAP-SHOT OF A KL10 SYSTEM!

(cont.)

ALL KL10's

<u>TYPE TO KLD</u>	<u>WHERE</u>	<u>WHAT</u>
FX1		;TURN ON CLOCK, TO ALLOW INTERRUPTS WITH EXAMINES.
EM16,17		;CAN YOU EXAMINE?
EX700000 17	P. 34	;APRID.
EM17		;OPTIONS,VERSIONS,SERIALS.
EX 700240 17	P. 34	;CONI APR.
EM17		;PROCESSOR ERROR, STATUS.
EX 701040	P. 37	;DATAI PAG.
EM17		;AC BLKS,SECTION, UBR.
EX 701240 17	P. 37	;CONI PAG.
EM17		;ENABLES, EBR.
EX 700400 17		;RDERA.
EM17	P. 35	;ERROR ADDRESS REGISTER.
D.T.E.M.		
EX 720240 17	P. 1-26	;CONI DTE#0.
EM17		;DTE STATUS.
EM ?500,?501		; ? = UBR.
	P.22or23	;?500 = PAGE FAIL WORD. ;?501 = PAGE FAIL PC+FLAGS.
AC BLK 7	P.32&33	;MICRO-CODE AC BLOCK.
EMO,2	P.32&33	;AC0=AR DATA FOR PAGE FAIL. ;AC1=ARX DATA FOR PAGE FAIL. ;AC2=I/O PGF WORD
AC BLK 0		;SET AC BLOCK TO 0.

(cont. on next page)

COMPANY CONFIDENTIAL

HOW TO GET A REAL SNAP-SHOT OF A KL10 SYSTEM!

(cont.)

FOR YOUR INFORMATION:

- D.T.E.M. = DTE Manual.
- Page numbers with NO letters are in the KL Maintenance Handbook.
- Page Table information is located on pages:
22, 23, 24, 25, 26, 27, 32, 33, and 40.
 - Pages: 22 & 23 - gives page table by location.
 - " 24 & 25 - gives breakdown of page table entrees for KL paging.
 - " 26 & 27 - gives breakdown of channel EPT area entrees.
 - Page: 32 - gives breakdown of "PC WORD".
 - " 33 - gives breakdown of PAGE FAIL WORD.
 - " 40 - gives breakdown of CHANNEL COMMAND WORDS.

G O O D S T U F F I N D E X

(FOURTH QTR. - FY 78)

ISSUE NO. 6

- CHECK YOUR POWER SUPPLIES.
- DMA2Ø TIMING.
- DFRHB A10.
- AR AND ARX PARITY ERRORS IN THE KL1Ø.
- ARE YOU A CLOCK WATCHER?
- PM AND PV INSTALLATIONS.
- ARE YOU RUNNING FROM COPS.
- AIR FLOW VANE SWITCH ADJUSTMENT ON KL PROCESSORS.
- PATCHES TO THE KL-1Ø CPU EBOX DIAGNOSTICS.
- KL1Ø CARD CAGE.
- CONTROL YOUR MEMORY.
- HOW TO GET A REAL SNAP-SHOT OF A KL10 SYSTEM.



COMPANY CONFIDENTIAL

Good Stuff

ISSUE NO. 7 - MAY/JUNE

This document contains sensitive information which shall not be disclosed to personnel outside of Digital Equipment Corporation.

This Newsletter is meant as an information document. It's contents are not necessarily Company Policy. It's a means by which LCG Product Support can distribute some tidbits of information to you.

GOODSTUFF DISTRIBUTION

BY: NANCIE MITCHELL

Below, I have outlined the procedure for making additions, deletions, and changes to Goodstuff.

In each of the following (3) cases the information must be sent to:
Nancie Mitchell - MR1-1/S35 - (TWX Code MR11).

Additions: Simply send a Twx or memo stating the fact that you wish to be added to the distribution of Goodstuff--your name, Badge #, CC, and Loc. Code.

Deletions: In this case it would be greatly appreciated if you would simply staple the label off of the envelope you receive Goodstuff in onto a piece of paper stating that you wish to be deleted from Goodstuff distribution.

Changes: Changes can also be made to the Goodstuff distribution by returning the actual mailing label with the appropriate change or changes written directly on the label.

BELL MODEMS FOR DEC 20'S

BY: AL SNYDER/JOHNNY ANDERSON
PRODUCT SUPPORT - ROLLING MEADOWS

Bell has recently released a new modem designated as a 212A. This modem will work, however, there is an option switch that must be in the YD position. If it is in the YE position as it is shipped, the modem will go into an analog loopback immediately when dialed.

G8010'S (-5.2 VOLT CONTROL) CAN CAUSE CIRCUIT BREAKER TO POP

BY: HERMAN MILLET
LCG QUALITY ASSURANCE

The heat sinks on the G8010 modules, located in the H761 power supply, can touch each other causing the circuit breaker to pop. This problem does not damage the machine, but it may become a nuisance in trying to track down the cause of the tripped circuit breaker. There is an FCO in the Field today to add zener diodes to the G8010's. This FCO is G8010-R-0003. It is recommended that during the course of reworking these modules you also install a small strip of electrical tape between the heat sinks. This should insure that they will not cause problems when re-installed in your system.

MODULE FIELD SERVICE SPARES

"D.O.A."

BY: TOM HAGSPIEL
QUALITY ENGINEERING

UNPLUG YOUR SBUS

BY: MIKE FLYNN
PRODUCT SUPPORT

It is possible that the DMA20 may confuse the MBOX control logic in the KL10. An example of this may be something like--you are running the "B" string and it comes to the first MBOX diagnostic (DGKBA), and this diagnostic fails saying something is wrong with the signal "core busy". But really, the DMA20 sent some signals to the MBOX (because it was broken), which confuses the MBOX.

To determine whether the MBOX or the DMA20 is broken try unplugging the SBUS from the MBOX and run the diagnostic again.

This situation may also occur with internal memories or any other device which may get connected to an SBUS.

EDITOR. William Fischer
ASSOC. EDITOR . . Nancie Mitchell
EDITORIAL OFFICE. MR1-1/S35

GOODSTUFF is published on a monthly basis.

The Field Service D.O.A. issue continues to cause concern for both the Field as well as the factory.

While we have seen improvements as a result of the time and efforts expended to-date, we have not been successful in resolving the D.O.A. issue to the satisfaction of either the factory or the Field.

In order to provide a measurement of the magnitude and validity of the Field D.O.A. problem the factory has implemented the following plan:

- a) D.O.A. modules will be separated and processed through module repair/test as controlled lots.
- b) D.O.A. modules will be reviewed by Quality/Manufacturing Engineering after repair and test.
- c) D.O.A. modules that are not verified as defective at module repair/test will be subjected to additional testing by Quality/Manufacturing Engineering.
- d) Monthly test results for D.O.A. modules will be published by Quality Engineering.

In conjunction with the factory plan, Field Service should include on the D.O.A. tag additional information, i.e., failure mode, diagnostic or program being run, solid or intermittent, etc. This will allow the factory to intelligently troubleshoot and correct the failure.

Working together, successful resolution of the D.O.A. issue is an obtainable goal.

COMPANY CONFIDENTIAL

PERSONNEL CHANGES IN THE LCG FIELD SUPPORT GROUP

BY: BILL FISCHER
LCG FIELD SUPPORT

In an effort to continually increase the quality and level of support which we provide I would like at this time to announce two changes in the LCG Field Support Group.

First, I would like to announce the promotion of Art O'Donnell to Product Market Support Supervisor. Art has been fulfilling the duties of Supervisor of the Field Quality Group. The success of this group in addressing support-level issues on all LCG products has prompted Art's promotion to Product Market Support Supervisor. Art, during his career at Digital has progressed from a Branch Service Engineer to acting Branch Supervisor, to his present position.

Please join with me in wishing Art continued success in his Digital career.

The second announcement I would like to make at this time is that John Swan has accepted a supervisory position in the LCG Field Support Group. John will be supervising the Applications/Tools Group. This is a new function which will enable us to better address long-standing issues.

During the past 18-months John worked as a Special Project Coordinator for Walter Manter. In this job John was very successful as a high-level project manager working system level issues across documentation, course development, training and DDC. His new job will encompass these responsibilities plus a myriad of new issues.

Please join with me in wishing John continued success in this new endeavor.

REV 11 MODULE COMPATIBILITY

BY: HERMAN MILLET

LCG QUALITY ASSURANCE

First of all I want to clear up the following misunderstanding. KL10 revisions 10A and 10B/2A are documentation changes only. They require no Field hardware rework. In fact, 10A and 10B may not be released until some time after Rev 11. Therefore, a system is upgradable from Rev 10 to Rev 11.

There is a potential for confusion with Rev 11 modules at this time. The RH20/DTE modules may not be available at the old revisions because Logistics is only stocking the new revisions. Of the modules affected, there is only a possibility of a problem with one of them.

The modules in question are as follows:

- The M8554 at Module Revision Level "F"
- The M8555 at Module Revision Level "D"
- The M8556 at Module Revision Level "D"
- The M8557 at Module Revision Level "D"

The M8554, M8555, and M8556 at the above stated revision levels are compatible with an integral system revision level now in the Field. They will play in any mixture of revision modules in the RH20. The M8557 at MRL "D" however, is designated as not being downward compatible. The reason why it was noted as such is because it breaks several diagnostics. The module will work on an operating system.

If you order any of the above mentioned modules from Stockroom 17 in Woburn you will probably get the new revision module since that is all that they have. Because of this you will have to use the M8557 at MRL "D" and I will describe the checkout procedure you should use to verify that you have a good module.

The M8557 at MRL "D" breaks the following diagnostics:

- DFSXA. At Test 11
- DDRPI. At NEXTST
- DFTUE. At Test 23

Note that DFRHB runs and is a valid diagnostic checkout of the M8557 module. If you receive an M8557 at Rev "D" and the diagnostic failures you get are only the ones noted above then you can assume that you have a good M8557 module. However, we recommend one further checkout of this module and that is to bring the monitor up from KLAD to minimize the risk of damaging the customer's file system.

The FCO's that will tell you how to upgrade your systems from Rev 10 to Rev 11 or Rev 2 to 3 for Model B CPU's, have not been released yet. Also, LC comp which would indicate the compatibility of the above modules has not been released yet.

(cont. next page)

REV 11 MODULE COMPATIBILITY
(cont.)

ALERT-----ALERT-----ALERT-----ALERT

This message does not supersede an earlier message concerning TOPS20 release 3, the RH20 at Rev 11 and the backup registers. In the event you must use one of the above modules prior to installing Rev 11/3 the customer still should not turn on his backup register.

ALERT-----ALERT-----ALERT-----ALERT

I have attempted to explain this situation and describe the recommended ways you can handle this problem. I am also aware that there may be situations I have not covered or peculiar circumstances which may arise. If you have any questions regarding this problem please call me at 231-5148 (Tie Line - Marlboro) or 617-481-9511 ext. 5148, in Marlboro.

MANUALS

BY: JOHN SWAN
CORPORATE SUPPORT

Some time ago we made a survey through Field Offices of those manuals which people would like to have in hard copy format. The result of the survey is that ten manuals have been printed and are available through Communication Services in Northboro.

Please find a list of these manual below:

- DEC10 SITE PREP GUIDE EK-DEC10-SP-005
- DEC20 SITE PREP GUIDE EK-DEC20-SP-002
- DEC20 INSTALLATION PROCEDURES EK-20XX-IN-PRE
- DEC 1080/1090 INSTALLATION PROCEDURES EK-1080U-IN-PRE
- MBOX UNIT DESCRIPTION EK-MBOX-UD-004
- EBOX UNIT DESCRIPTION EK-EBOX-UD-004
- MB20 UNIT DESCRIPTION EK-MB020-UD-001
- DTE20 UNIT DESCRIPTION EK-DTE20-UD-003
- RH20 UNIT DESCRIPTION EK-RH20-UD-001
- DEC20 BUS SYSTEM INTERFACE DESCRIPTION EK-BUS-ID-001

COMPANY CONFIDENTIAL

DFTUE TEST 23 FAILS

BY: HERMAN MILLET

LCG QUALITY ASSURANCE

With an RH20 at Rev 11 or an RH20 with an M8557 at module revision level "D", DFTUE fails test 23. You can correct this problem by installing the following patch:

<u>CHANGE LOC</u>	<u>FROM</u>	<u>TO</u>
137	Ø,,5	2,,5
54466	26Ø74Ø,,5Ø3Ø5	254ØØØ,,1Ø4671
54475	26Ø74Ø,,5Ø3Ø5	254ØØØ,,1Ø4674
1Ø4671	Ø	26Ø74Ø,,5Ø3Ø5
1Ø4672	Ø	26Ø74Ø,,46Ø12
1Ø4673	Ø	254ØØØ,,54467
1Ø4674	Ø	26Ø74Ø,,5Ø3Ø5
1Ø4675	Ø	26Ø74Ø,,46Ø12
1Ø4676	Ø	254ØØØ,,54476

PAGE FAIL CODES

BY: MIKE FLYNN

PRODUCT SUPPORT

The KL10 has particular two-digit codes that appear in the first two octal digits from the left of the page-fail word in location 500 of the user process table (UPT). These two-digit codes also appear in the AC as a result of a map instruction. There is a page-fail code that is not described anywhere. It is a code of "00". A code of "00" means that an entry for that page of core has never been made or the entry is all zeros. This could happen if a patch was made to the TOPS20 operating system, and this patch was installed into a page that the operating system did not know existed. Trying to execute these instructions will get you a page-fail code of "00". The following is a list of page-fail codes and their meanings.

- 00 Page Entry Empty
- 21 Proprietary Violation
- 22 Refill Error
- 23 Address Compare
- 24 Illegal Indirect
- 25 Page Table Parity
- 27 Section > 37
- 36 AR Parity
- 37 ARX Parity

COMPANY CONFIDENTIAL

"MA/MB2Ø ADD-ON"

BY: DON WERTH

PRODUCT SUPPORT

In order for KLINIT to configure some combinations of MA2Ø and Add-on MB2Ø memories so that all available memory will be utilized by TOPS-20 monitor the MA2Ø/MB2Ø storage modules must be installed in specific storage module locations.

Memory Size	MA2Ø-M Location CØ and C1	MB2Ø-M Location C2 and C3
64K MA2Ø and 64/128/192K MB2Ø	SMØ } 64K SM1 }	SM1 } 64K } 128K } 192K SM2 } SM3 }
96K/128K MA2Ø and 64K/128K MB2Ø	SMØ } 96K } 128K SM1 } SM2 } SM3 }	SM2 } 64K } 128K SM3 }

These configurations however, will break the diagnostic "DGKBB/DHKBB":

```

MAINDEC-10 DGKBB
MEMORY SYSTEM DIAGNOSTIC VER 1.10 JAB29857
SWITCHES = 000000
UCODE VERSION 126, CLOCK RATE 0,
PROCESSOR ID #2169.
    
```

MEMORY REPORTED:

CONTROLLER ADDRESS	TYPE	STORAGE							
		7	6	5	4	3	2	1	0
0	MA20	0	0	0	0	1	1	1	1
1	MA20	0	0	0	0	1	1	1	1
2	MB20	0	0	0	0	0	1	0	0
3	MB20	0	0	0	0	0	1	0	0

```

***** MEM CONTROLLER 0
***** MEM CONTROLLER 1
***** MEM CONTROLLER 2
FAULT DETECTED
SOLID FAULT
    
```

TEST NUMBER - 17. SUBTEST - 1. PC = 31776

```

ERA WORD: 026000 600000
NXM ERROR
INTERNAL MEM MOD SEL ERR
    
```

(Cont. next page.)

COMPANY CONFIDENTIAL

"MA/MB20 ADD-ON"
(CONT.)

A patch has been made available (courtesy Jeff Barry) to remedy this.

<u>DGKBB VER 1.10</u>		<u>DHKBB VER 1.1</u>	
<u>LOCATION</u>	<u>SHOULD BE</u>	<u>LOCATION</u>	<u>SHOULD BE</u>
67066	126061	67066	126061
67070	042270	67070	042262
67072	014762	67072	015020
67074	000207	67074	000207
27504	004737	27560	004737
27506	067066	27562	067066
27510	101362	27564	101362

Detailed installation instructions will be available in the near future.

KLAD PACK INFORMATION

BY: GENE YONCHAK
M.E.G.

"YOU MAY HAVE RECEIVED A COPY OF THIS MEMO WITH INCORRECT PART NUMBERS AND PRICES. THE PART NUMBERS/PRICES LISTED IN THIS DOCUMENT ARE CORRECT".

The KLAD20 pack that all of you have come to know and love has undergone a change in material format. Field Service Product Support has caused several new changes to be instituted, and this information must be transmitted to all DECSYSTEM-20 sites at the earliest possible time.

1. Identifying Nomenclature

As of February 1978, all KLAD 20 System packs accompanying systems from FA&T have been upgraded to TOPS20 Release 3, and contain the latest release of diagnostic software. In order to provide some method of identifying material content, we have generated a unique label that identifies material according to software root derivatives.

EXAMPLE: KLAD20-K-3.0-B

(Cont. next page)

COMPANY CONFIDENTIAL

KLAD PACK INFORMATION
(CONT.)

1. Identifying Nomenclature

This label will be on all KLAD20 pack delivered to the Field after March 15, 1978, and reveals the following information:

- A. KLAD20 is the type of klad pack involved.
- B. The letter "K" indicates that the diagnostic software used to generate this version of KLAD was derived from the diagnostic magtape DFXLK. This letter will change to match the change in the nomenclature of the diagnostic magtape.
- C. The numbers "3.0" indicate the version of TOPS20 software contained on this KLAD20 pack. This number will change accordingly with changes in the monitor release.
- D. The letter "B" is the 'patch' version of KLAD. The 'patch' version can be changed for a variety of reasons. The most common would be:
 1. A change in an individual diagnostic was necessary to "fix" a problem with a particular diagnostic, and this precedes the generation of a new diagnostic magtape release.
 2. A change was necessary to correct a problem with the operating system software, either in the front end, or the monitor.
 3. A change was necessary to some individual support files normally found on KLAD.

Should this revision letter be of any value other than the letter "A", the Field Service Engineer must be made aware of the reason that caused this change. For this reason, we have added a "special" directory that contains information relative to KLAD.

This directory is called <KLAD>, and normally contains 2 files:

1. KLAD20.MEM - This is the "hand-holding" document that contains the procedures for generating a KLAD PACK (assuming that the necessary materials are available).
2. KLAD.UPD - This file is the one that contains a history of all changes that makes this particular KLAD PACK different from its previous version. This file will be updated every time: (1) A new version of KLAD is generated, (2) any time it is necessary to change the "patch" letter of KLAD.

(Cont. next page)

KLAD PACK INFORMATION
(CONT.)2. New Directories on KLAD20

In addition to this new directory, several other directories have been added to the KLAD20 pack.

1. <MANUALS> - This directory is provided so that the most recent line-printer versions of the TOPS20 software documentation can be made available to F.S. Engineers. NOTE: Because of the availability of the documentation material, these files may not always be up-to-date.

***** WARNING *****

These files may not be given to the customer. They do not contain many of the references and illustrations the customers are accustomed to seeing.

2. <UTILITIES> - This directory contains all of the files necessary to create a copy of KLAD on magtape, and the files necessary to restore the KLAD20 "DUMPER" tapes to disk.
3. <FAULT-INSERTION> - This directory contains the fault insertion programs written by F.S. Product Support to test the KL parity detection software in TOPS20 Rel. 3.0.

***** WARNING *****

These files should not be used in conjunction with a customers' software. These files can, and will cause a variety of parity errors and monitor bug halts/crashes depending which program is being executed.

4. <UETP> - This directory is currently empty. It was provided in the event the "user environmental test package" becomes a part of the standard software distribution package.
5. <ACCEPT> - This directory contains all of the files associated with the FA&T 72-hour acceptance test. It will be the responsibility of Manufacturing to update these files on a continuing basis.
6. <HINTS> - At present, this directory is empty. We have provided for the distribution (via KLAD) of any "un-official" information thought to be of interest to the Field. The data in this directory must be in ASCII test format, and must contain the originators name, DEC Location, and phone number. It may not contain any source code, to be assembled at a later date.

(Cont. next page)

COMPANY CONFIDENTIAL

KLAD PACK INFORMATION
(CONT.)

3. KLAD Part Numbers and Ordering Procedure. (KLAD10 and KLAD20)

As a result of Product Support requests, all KLAD systems now are under the control of L.C. Rev. and have part numbers assigned to each type of KLAD (KLAD10 or KLAD20) pack that will be effective on May 15th.

In addition to the KLAD-PACK, there have been part numbers assigned to KLAD "update kits". These kits are designed to allow the Field to order scheduled updates to existing KLAD systems. There is a specific ordering procedure that must be followed when ordering a KLAD-PACK, or an update kit. The cost for all material will be charged to the F.S. Branch ordering the KLAD material. To date, an automatic distribution method has not been established.

A. Part Numbers - KLAD10 and KLAD20

1. KLAD10 RP04 Disk Pack - ZH101 PK \$ 589.00
CONTAINS: One (1) RP04 Disk pack, and one (1) diagnostic magtape. Unless specifically directed, the content material will be the latest version.
2. KLAD10 RP06 Disk Pack - ZH102 PL \$1514.00
CONTAINS: One (1) RP06 Disk pack, and one (1) diagnostic magtape. Unless specifically directed, content material will be the latest version.
3. KLAD20 RP04 Disk Pack - ZT101 PK \$ 589.00
CONTAINS: One (1) RP04 disk pack, and one (1) diagnostic magtape. Unless specifically directed, content material will be the latest version.
4. KLAD20 RP06 Disk Pack - ZT102 PL \$1514.00
CONTAINS: One (1) RP06 Disk pack, and one (1) diagnostic magtape. Unless specifically directed, content material will be the latest version.
5. KLAD10 Update Kit - ZH100 \$ 100.00
CONTAINS: Front-end Dec Tapes (3), KLAD10 "BACKUP" format magtapes, and a "how to do it" build document.
6. KLAD20 Update Kit - ZT100 \$ 100.00
CONTAINS: System floppies (A,B, and C), 3 "dumper" format magtapes, and a "how to do it" build document.

(Cont. next pag

KLAD PACK INFORMATION

(CONT.)

B. Ordering Procedure

Now that part numbers have been assigned to KLAD packs, it was necessary to institute an ordering procedure to prevent this diagnostic tool from being ordered without proper authorization. For this reason, we have chosen to utilize the DEC "I.O.F." (Internal Order Form). This form must be filled (as illustrated by attached example) by the person requesting the KLAD material; must have a shipping address; must have the signature and badge # of the individuals' Branch or Unit Manager; and be forwarded directly to LCG F.S. Product Support for approval. This form will be given to S.D.C. where it will be filled and sent to the F.S. Branch Manager of the individual requesting the KLAD material.

NOTE: S.D.C. has been instructed to ship only to bona-fide DEC offices! They will not ship KLAD material to a customer site! There are contingency plans to allow for the delivery of KLAD material to those places where the "bona-fide DEC Office" happens to be in individuals' home.

S.D.C. will provide a 2-hour turn-around time for all Field requests, provided that the I.O.F. form be received by Product Support in Marlboro, by 11:00 hours, Monday through Friday, and a 24-hour turn-around time if received (via telephone) on weekends.

In the event of a major catastrophe, and the delay caused by the I.O.F. form is unacceptable, there is a procedure whereby a Branch or Unit Manager may telephone his request to LCG Product Support. He must supply all of the information normally supplied on the I.O.F. form, and Product Support will authorize a verbal approval to ship the requested KLAD Pack. This procedure will be available only for the emergency replacement of a KLAD10 or KLAD20 disk pack, and not KLAD update kits! After completing his telephone request for KLAD material, the Branch, or Unit Manager must complete the I.O.F. form and submit it to LCG Field Service Product Support in Marlboro, with the notation "emergency telephone request filled on: DD-MM-YY" in the box "special instructions".

(SEE FORM ON NEXT PAGE)



COMPANY CONFIDENTIAL

INTERNAL
ORDER
FORM

REG. FAC. CODE	BOOK CTR.	D.E.C. NO.
----------------	-----------	------------

REQUESTED BY

Jay Random #123456

LOCATION

CC 123

EXT.

000

DATE

3-15-78

RESP. PROD. L

F.S.

USE: IN-HOUSE DEMO TRADE-SHOW OTHER Field Service

DELIVER TO:		LINE VOLTAGE N/A	LINE FREQ. N/A	REQ. DEL. DATE ASAP	SCH. DEL. DATE ASAP
NAME	Mr. F.S. Manager - c/o Digital Equip.	EQUIP. TO BE RETURNED?		COST CTR.	
ADDRESS	123 Digital Blvd.	<input type="checkbox"/> YES, WHEN? <input checked="" type="checkbox"/> NO			
OR	DEC City, USA Zipcode	TYPE ORDER		MODEL NO.	
D.E.C. LOC.		<input type="checkbox"/> SYSTEM <input type="checkbox"/> ADD-ON <input type="checkbox"/> SPARE		KL10 SERIAL NO 2345	
				TO BE CAPITALIZED	
				<input type="checkbox"/> YES <input checked="" type="checkbox"/> NO	

REASON FOR REQUEST KLAD update (or) KLAD replacement

SPECIAL INSTRUCTIONS:

Forward directly to LCG F.S. Product Support - MR1-1/S35
for approval - ATTN.: Product Support Supervisor

ITEM	QTY	MODEL NO.	DESCRIPTION	P/L CODE	PART. ALLOW.	STANDARD UNIT PRICE	AMOUNT
1.	1	KLAD-10	ZH101 P K Klad System (RP04)	-	-	\$ 589.00	\$ 589.00
2.	1	KLAD-10	ZH102 P L Klad System (RP06)	-	-	1514.00	1514.00
3.	1	KLAD-10	ZH100 Klad Update Kit	-	-	589.00	589.00
4.	1	KLAD-20	ZT 101 P K Klad System (RP04)	-	-	1514.00	1514.00
5.	1	KLAD-20	ZT102 P L Klad System (RP06)	-	-	100.00	100.00
6.	1	KLAD-20	ZT100 Klad Update Kit	-	-	100.00	100.00
TOTAL							

COST CENTER MANAGER	DATE	P. L. MANAGER FURNISHING EQUIPMENT	DATE
FINANCE	DATE	SCHEDULING RESTRICTION To be completed by SDC	

1. COMPUTER ADMINISTRATION

2. FINANCE

3. PRODUCT LINE

4. ORIGINATOR

ISSUE NO. 1

- CONTACTING CORP. SUPPORT AFTER HOURS
- LCG CORP. P.S. REORGANIZATION
- MH10 PERFORMANCE IMPACT
- KL10-PM
- KL REV. UPDATE UPDATE
- THE MISSING LINK
- FIELD NOTIFICATION
- KL10 CORRECTIVE MAINT. NOTIFICATION
- 1090 SOFTWARE PROBLEMS
- INSTALLATION REPORTS
- RP04 ADJUSTMENT
- KLAD-20 TIPS AND TIDBITS
- WHAT'S NEW WITH MEMORY SPARES
- KL CPU BACKPLANES
- DX10 MICROCODE

ISSUE NO. 2

- TECH DOC NEEDS HELP!
- WHERE SHOULD YOU STICK YOUR SBUS?
- SHOULD MH10'S "WARN" KL10'S?
- USING MAPOUT UNDER DDRPI
- CAN'T TALK TO YOUR MAGTAPES ON DECSYSTEM-20'S?
- DC20-EC COMM. EXPANSION CABINET POWER REQ.
- BAC-UP AND TRY AGAIN.
- INSTALLATION SHORT SHIPS.
- PROBLEMS LOADING MICROCODE WITH VERSION 12 OF KLDPC.
- H744 REGULATOR FCO.
- THE ELUSIVE EXTENDER.
- PATCH THE DIAGNOSTIC INDEX.
- DN87-S UNIBUS...HOW LONG IS LONG?
- WANT TO USE 6.03/RSX20F FOR YOUR 1080/1090 SYSTEM?
- CRAM YOUR KL.
- DDANA-AN10 DIAGNOSTIC.
- SELF-PACED AUDIO/VISUAL COURSE.
- LC REV. (WHAT-WHERE-WHY?)
- KLDPC...1,2,3
- NEW VERSION OF SYSERR.
- INSTALLATION AND WARRANTY CHARGE POLICY.
- KL REVISION 10.
- IS YOUR KL HUNG?
- KLAD 20 PACKS.
- THE A B C'S OF KL NUMBERING.
- BASIC INTEGRAL SYSTEM NOMENCLATURE DEFINITIONS
- KL10 INTEGRAL SYSTEM TABLE.

ISSUE NO. 3

- WHERE THERE IS SMOKE THERE IS FIRE?
- DX10 ERROR REPORTING AND 6.03.
- DIAG. HOTLINE.
- F.S. STOP ON 1090'S.
- 6.03 BUG.
- A DIAGNOSIS OF THE POLICIES AND PROCEDURES OF THE DDC.
- CLEARING SHADOW CORE - KL10'S.
- TOPS20 MEMORY CONFIGURATION.
- RE-SETTING THE DTE20.
- M8554 REV. E - CONCERNS.
- IS YOUR PROBE TIPPED?
- NOT ENOUGH CORE.
- GOIN' FICHIN'
- IS YOUR P.A. SYSTEM BEING PV'D?
- KL10 POWER CONNECTORS.
- FIELD UPGRADE PROBLEMS WITH MB20.
- 28 AWG TWP WIRE.
- SYSERR FIX FOR KLERR LISTINGS.
- TIME TO ADJUST YOUR CLOCKS?

ISSUE NO. 7

- GOODSTUFF DISTRIBUTION.
- BELL MODEMS FOR DEC 20'S.
- G8010'S (-5.2 VOLT CONTROL) CAN CAUSE CIRCUIT BREAKER TO POP.
- UNPLUG YOUR SBUS.
- MODULE FIELD SERVICE SPARES "D.O.A."
- PERSONNEL CHANGES IN THE LCG FIELD SUPPORT GROUP.
- REV11 MODULE COMPATIBILITY.
- MANUALS.
- DFTUE TEST 23 FAILS.
- PAGE FAIL CODES.
- MA/MB20 ADD-ON.
- KLAD PACK INFORMATION.

ISSUE NO. 4

- FCO CONTROL
- LCG QUALITY ASSURANCE GROUP
- NEW TTY LINE NUMBER ASSIGNMENTS
- LCG TRAINING COORDINATOR
- M8554 REV. E MODULES
- SUPPORT EQUIPMENT
- LARS???
- TO LED OR NOT TO LED
- TOPS-10 INFORMATION.
- DN20 MODEM REQUIREMENTS
- MA/MB20 CONTROLLERS
- KLDPC EM COMMAND PROBLEM
- CACHE RAM BANGER DIAG. HALTS
- WHICH VERSION 157 IS "YOUR" VERSION 157 MICROCODE?
- MORE 6.03 BUGS.
- KL10 BACKPLANE TIP
- GOT CLOCK PROBLEMS?
- DX10 MICROCODE AGAIN
- 845 POWER CONTROL ECO - ECO 12 - MANDATORY ECO.
- THE HALT LOOP
- CNTL-S PROB. ON DC20 USER LINES (DH11)
- INCOMPLETE INFORMATION FROM AN ISSUE 2 ARTICLE
- DEC20 FRONT END TROUBLESHOOTING

ISSUE NO. 5

- NIV STOP CODES
- BRADY MARKERS
- LED ORDERS
- KEEP ALIVE CEASED
- LA36 FAILURES AS CTY ON DECSYSTEM-20'S
- RH20-TM02/TM03-TU16/TE16/TU45 MAGTAPE BASIC DIAG. "DFTUE" VER 5.0
- TM02 - 8901 YC REV J
- FOR YOUR INFORMATION - RE: 6.03 BUG
- RUNNING DDQCB
- DX10 MICROCODE
- TX01 SPARES
- NEW PROGRAM: MEMCON - KL10 MEMORY CONFIGURATOR
- STC VS. DEC PART NUMBERS.
- BACKUP AND DUMPER ERROR RECOVERY.
- RP04/5/6 DIAG FAILURE - FALSE "OPI'S"

ISSUE NO. 6

- CHECK YOUR POWER SUPPLIES.
- DMA20 TIMING.
- DFRHB A10.
- AR AND ARX PARITY ERRORS IN THE KL10.
- ARE YOU A CLOCK WATCHER?
- PM AND PV INSTALLATIONS.
- ARE YOU RUNNING FROM COPS.
- AIR FLOW VANE SWITCH ADJUSTMENT ON KL PROCESSORS.
- PATCHES TO THE KL10 CPU EBOX DIAGNOSTICS.
- KL10 CARD CAGE.
- CONTROL YOUR MEMORY.
- HOW TO GET A REAL SNAP SHOT OF A KL10 SYSTEM.

Good Stuff

This document contains sensitive information which shall not be disclosed to personnel outside of Digital Equipment Corporation.

This Newsletter is meant as an information document. It's contents are not necessarily Company Policy. It's a means by which LCG Product Support can distribute some tidbits of information to you.

ISSUE NO. 8 - JULY

ANNOUNCEMENT - ANNOUNCEMENT

RELOCATION OF THE DDC

BY: BEN BATTLE
NORAM DDC 10/20

We are sad to announce that Bill Fischer will no longer be the editor of GOODSTUFF but at the same time--we are pleased to announce that effective July 1st, Art O'Donnell will become the successor to Bill Fischer as editor of GOODSTUFF. As editor, Art will resume all of the responsibilities Bill has been involved in regarding GOODSTUFF--i.e.: reviewing the articles for accuracy, final review and acceptance of actual publication for print, distribution review, etc.

If you should have any suggestions/problems regarding GOODSTUFF, please feel free to notify Art at the Editorial Office in Marlboro.

The NORAM DDC 10/20 will be relocating to a new facility in Colorado Springs, Colorado. As of June 26, 1978, the new telephone numbers for the DDC will be as follows:

800-525-6570

This number should be used to log a service call for a DDC response. It should be used by all of NORAM Continental U.S.A.

303-599-4000

This number should be used to contact specific engineers in the DDC and should be also used in Canada to contact the DDC.

COMPANY CONFIDENTIAL

LCG MICROFICHE LIBRARY
AND VIEWER

BY: GRAHAM MORLAND
LCG QUALITY ASSURANCE

On new system shipments a microfiche library and a microfiche viewer is supplied. The viewer is shipped with the system. However, the fiche library is sent directly to the installing Branch Office, prior to system delivery, addressed to the Field Service Manager.

If you do an inventory and find the library missing, here's the reason why! Contact your Supervisor or Manager, he should have it.

KEEP ALIVE CEASE ON DECSYSTEM
20'S

BY: RICH CATENA
D.D.C.

It is possible for spurious power fail interrupts on the KL processor (from APR, power supply logic, etc.) to cause keep alive cease problems. When the location PWRDWN is seen to be non-zero during the beginning of a scheduler cycle, the code goes to the power fail code in the APRSRV. Towards the end of the power fail code the P1, cache and KL paging is turned off, location PWRDWN is set to -1 and loops in the AC's waiting for power to go away. The front end however, may complain about a keep alive ceased before the loop is finished. To determine if any of your Keep Alive Ceased problems are due to spurious interrupts, (there are many others) you can look at the dump of the dead monitor. If the loop code is in AC 5 and 6 and PWRDWM equals -1 then you have this problem. The loop code is as follows:

- 5/ SOJG T1,Q1
- 6/ JRST SCHPR2

231 \$278
EDITORArt O'Donnell
ASSOC. EDITOR...Nancie Mitchell
EDITORIAL OFFICEMR1-1/S35

GOODSTUFF is published on a
monthly-basis.

KL10 VOLTAGE MARGINING
PROCEDURE
AND "SEIGE"

BY: BILL HILLIARD
PRODUCT SUPPORT

On 10-October-77, I sent a memo to all Regional Product Support Supervisors titled "KL10 VOLTAGE MARGINING PROCEDURES". The body of the memo was as follows:

"The purpose of this memo is to present a KL10 voltage margining procedure for use by Regional Support Engineers only. It is not intended for general distribution at this time. We hope to gain useful information about the value of voltage margining on KL10's before this procedure is released to the entire Field."

During the seven-month period following that memo, I have received exactly one input from Regional Support Groups. Furthermore, in the course of my travels, I have found the procedure being used routinely by Branches for any and every failure.

I would like to re-emphasize that voltage margining on KL10's is not a general procedure to be used in a routine manner. I would also ask for any inputs you have on this subject. We have experienced problems with

machines that had one intermittent failure fixed by "seige". "Seige" = voltage margins "and" vibration testing "and" temperature cycling "and" power cycling. The result was one intermittent failure and nine solid failures. There is no proof that "seige" caused the failures but that is due to lack of evidence (inputs!).

Remember, if you use these techniques without self-control, you may buy the farm!

TU45 FIELD ADJUSTMENT
PROCEDURE
FOR UNITS USED ON PDP-10 OR
PDP-11

NUMBER TU45A-0-5 DTD 23 JUNE

BY: CARY DEVAN
PRODUCT SUPPORT

I would like to add to Part I, Paragraph #3 a check for the 800 HRZ OSC output on TP12. If you don't have the correct output all subsequent adjustments will not make the drive work.

For the correct output refer to the PERTEC Manual on the TU45 and the schenatic power supply (G1) T9000 DWG. No. 104582.

NOTE: The corrected version of the TU45 adjustment procedure will be republished in the coming months.

COMPANY CONFIDENTIAL

TROUBLESHOOTING TOPS20 MACHINES

BY: PAUL CLARK/GLENN FOLEY
IHFS LCG

The following techniques were useful in troubleshooting problems on TOPS20 machines.

BUGHLT APRNX1:

TOPS20 does not execute a read ERA instruction in the crash sequence for a BUGHLT APRNX1. Therefore, the information cannot be found in SYSERR or system dumps. The following patch to <SYSTEM> MONITR.EXE will cause the monitor to store the ERA in location FFF2+10. This location may then be examined by using FILDDT to analyze DUMP.CPY.

<u>LOCATION</u>	<u>PRESENT CONTENTS</u>	<u>CHANGE TO</u>
P1NXM	XCT APRNX1	JRST FFF2
FFF2	0,,0	RDERA,FFF2+10
FFF2+1	0,,0	XCT APRNX1

(This will be corrected in TOPS20 Release 3A)

BUGINF PH2DNA:

This message indicates an RH20 interrupted with the transfer done bit set but no transfer was requested from the controller. The message does not indicate which RH20 caused the interrupt.

To determine which RH20 is at fault, start by examining the contents of AC10. SYSERR supplies the contents of the AC's at the time of error. AC10 contains a pointer to a location which contains the number of the interrupting channel. Next, enter MDDT by doing a PEQUIT command and examine location "C(AC10)+CDBADR" where C(AC10) is the contents of AC10. The contents of this location is the channel number of the interrupting channel (0,1,2, etc.). You can now swap out that RH20 module set to fix the problem.

COMPANY CONFIDENTIAL

HOW TO GET DATA ON INTERMITTENT EBUS PARITY ERRORS

BY: BILL HILLIARD
LCG PRODUCT SUPPORT

EBUS parity errors have been more difficult to fix than necessary in the past primarily because the software wipes out the important information and people didn't know where to find the information even if it wasn't munged. The following steps may help you attack the problem.

1. Prevent the software (RSX20F) from "doing you in". This is done in two steps. First, disable front end reloading by the KL10 side either by the "ROM Reload Enable" switch on the DTE switch panel or by using the method outlined in GOODSTUFF Issue 4. Next, deposit a HALT instruction (000000) in PDP-11 memory where RSX20F attempts to service the EBUS parity error flag. This may require the help of your local software person or a phone call to HOSS. The location of interest can be found in the SCOMM module in a routine call WFED. This routine waits for examine/deposit transfers and checks for error conditions. In my listings, SCOMM is version 10-12 and the location to change is 44110. Address 44110 contained a 000407 and would be changed to 000000. This would allow setting of the flag in PDP-11 memory (bit 02 in location 031234) and then halt. You will have to obtain the correct location for your version software.

2. When the -11 halts, examine location 174434 which is the DTE status register. The interesting bits are bit 04, EBUS PARITY ERROR and bit 01, TO11ER. (Remember, don't press the "start" switch or you will reset the error bits).

3. If the TO11ER bit is not set the previous "examine" operation failed. If this is the case, examine DEXWD1, DEXWD2, and DEXWD3. This will give you the bad data. Use the following chart:

KL10 BITS	00 - 03	04 - 19	20 - 35
DEXWD1* (174406)	DEXWD2 (174404)	DEXWD3 (174402)	
PDP-11 BITS	15 - 04	03 - 00	15 - 00

*Bits 15-04 of DEXWD1 must be zero and are reserved by DEC.

cont. next page

COMPANY CONFIDENTIAL

Next, examine TENAD1 and TENAD2 noting their contents (TENAD1 = 174410, TENAD2 = 174412). By reloading these two registers with their current contents, you will force the examine operation to be retried. You must reload them in the order TENAD1 first, then TENAD2. Now if you examine DEXWD1, DEXWD2, and DEXWD3, you should get the Good Data unless the operation is failing solid. You can now compare the good and bad data to get the failing bit.

4. If the TO11ER is set, the previous "TO11 transfer" failed. If this is the case, start by examining the bad data in TO11DT, address 174426. Next, examine the output byte pointer (TO11) from EPT location 140. Calculate the effective address from the byte pointer and examine that location. Using the P and S field of the byte pointer you can now determine the byte of Good Data. Comparing the good and bad data, you can determine the failing bit. If the two words are totally different, you may have a dual select problem on the EBUS.

5. Other Notes:

Be aware that the DTE expects all bits to the left of the 16-bit byte in the 36-bit word transferred across the EBUS on a TO11 transfer to be zero's. These bits are not input to the parity computation in the DTE. If the bit is affected before it gets to the AR, you should get an AR PARITY ERROR. If it is affected after the AR, you won't see any indication.

Also, if you are getting EBUS PARITY ERROR but not CNT2 EBUS PARITY ERROR SET L (i.e.: false parity errors) check DPS5 STATUS LT L (from INT 1) and Unibus Data bit 02.

Finally, Field Service probe probably won't be much help in these problems since the DTE does not check parity until far after the Ebus transfer is completed (>64 microseconds).

LCG TRAINING STRATEGY

BY: JOHN SWAN
LCG PRODUCT SUPPORT

As part of my job as the LCG Training Coordinator, I have been working closely with Course Development and Training Operations over the last 12-months to build a strategy for a set of training courses which I will define as a "three-tier" approach. Let me explain what I mean by three-tiers.

The basic entry level to the first tier of these courses is the new-hire, or the engineer (DEC experienced) but not LCG experienced. The graduate from this first tier is a "generalist" whose entry level skills plus the training he receives in this course will enable him to perform the duties of an Account Representative working out of a Branch Field Office looking after several systems and particularly emphasizes maintenance techniques, tools and how to use them and the DDC as a Branch resource.

The second tier in the structure contains a set of specialist courses. These are aimed at the graduate from the first tier who has been working in the Field for typically 12-months. These specialist courses are offered in stand alone format. The length of each course is 2-3 weeks, and the subjects they cover are processors, disk subsystems, tape subsystems, hard copy subsystems, and specific communication devices.

The third tier contains a new set of courses currently under development entitled "Software for Field Service". These courses are aimed at the graduate from the second tier or the very experienced graduate from the first tier. Typically, this person will have at least two-years' experience in the Field working in a support function. He will also probably have a perceived aptitude for software. The courses offered in this tier are diagnostics, monitor internals, and RSX20F front end language.

Reviewing the three-tiers, the aim is to have a training mechanism to provide the skills and knowledge required to build:

1. A Branch Engineer.
2. A Support Engineer capable of passing the Engineering Review Board's requirements for Product Support Engineer.
3. The necessary knowledge required to be a System Engineer.

cont. next page

COMPANY CONFIDENTIAL

Already built and awaiting enrollment from the Field are the LCG System Introduction Courses. This is an 8-week course with a class size of 10-12 students which has been regularly offered since May of this year. The 2020 courses which started a couple of weeks ago are structured in the same manner. Specialist training in tier two will be effected by modifying the existing course "modules" in the current training string to accept a higher entry level, and therefore, aim at a higher exit level.

As already mentioned, the third tier courses are currently under development, and I expect the first string to be offered in October of 1978.

If you have any comments or suggestions on the strategy, I would be very pleased to hear from you either by memo or phone. You can reach me at MR1-1/S35 - EXT. 5504.

DFDTE FAILURES AT CLOCK RATE 2
BY: AL SNYDER/BILL HILLIARD

INSTALLATION OF MB20
ADD ON MEMORY
BY: HERMAN MILLET
LCG QUALITY ASSURANCE

DFDTE, the DTE20 functional diagnostic will fail when run at clock rate 2 in reliability mode. The versions affected are DFDTE version 0.10 and SUBRTN version 0.13. The failure is not solid in that it may or may not occur on any pass of the diagnostic. When it does show up, you will see PC=34063, "Error in Byte Transfer Word Mode Reliability - T010 Finished Before T011," CONI = , ACTUAL = 000141.

Have you ever tried to install an Add On MB20 memory and found that you were not sent the installation procedures? If this has happened to you, you are not alone. First of all, you should receive the installation procedure as part of the documentation shipped with the Add On. However, in an attempt to provide you with an alternate source of this information it is duplicated on the page of microfiche titled--"DEC SYS-20 INSTALLATION PROCEDURES". Section eight (8).

TOUCH-UP'S

BY: DENNIS LERRA
F.A. & T.

Below, please find the names and part numbers of the paint used on DEC10-20 hardware (add-ons).

A KL10 DESIGN DEFICIENCY PROCEDURE

BY: JOHN ALLEN
L.C.E.G.

In the I/O bay of all KL10 mainframes, there is an H770 regulator which supplies +15 volts to the CPU and I/O air flow sensors. When this power supply fails, all air flow and temperature sensing is silently disabled. This failure will not be detected until either the machine burns up due to air-conditioning or fan failure or until Field Service checks the output of the H770 power supply with a voltmeter. (Usually the indicator lamp bulb has already burned out).

This problem can be avoided by establishing a regular preventive maintenance procedure to check the power supply.

NOTE: A TECH TIP is also being written to address this problem - ref: KL10-TT-52. This will be included in the PM Procedures for KL.

PAINT NAME DEC PART #

Lo-Gloss Gray.....92-00000-68
Black Laquer.....92-100000-94
Blazi Blue.....92-00001-48
Terra Cotta.....92-00001-42
End Panel Gray....E.P.G.
Flat Black.....1602
Gray.....92-00001-01
Scale Gray.....92-00001-47

These paints can be ordered through either an E1/P1 order mode or through the Expenditure Stockroom #23 - Marlboro.

DEC-20 WITH DN20'S - WARNING!

BY: CONRAD ZWIRTZ
LCG F.S. - CHICAGO

Recently, we had an instance where a DEC-20 crashed. The Engineer dispatched found the problem (a hung DCL), then ran B string. It failed DGKAA test 7, subtest 2 signals. EBUS demand E H and 1/4IC5 EBUS PI GRANT. It also failed DGKAB test 26 subtest 2, same signals, plus EBUS CS00.

The solution--to halt the DN20, then the B string runs.

COMPANY CONFIDENTIAL

2050 OVERTEMP

BY: PAUL CLARK
IHFS LCG

The overtemp fault plague can be extremely punishing to F.S. personnel, users and operations alike.

Typically, the environment engulfing our machines is far from perfect and to make matters worse, temperature variations seem to occur at rather inconvenient times. Short-term or long-term override operation is hardly a satisfactory solution and the risk involved with leaving unattended machines in such a state is prohibitive.

Let me make some suggestions which will facilitate the isolation and replacement of the faulty component.

1. The first step, no doubt, is to ensure that all fans are operational. (The fault indicators on the H863 power controller will help by pointing to the problem area--i.e.: CPU, I/O, MEM 1 or MEM 2.
2. Secondly, it is possible that the G8017 or the G8015 module in this H863 power controller is faulty. (This is most unlikely, however if the problem is not solid).
3. The final and most probable cause is that one or more of the "air-vane sensors" in the machine is marginal. These faults are the most typical, how do we determine which of the switches is marginal?

Proceed as Follows:

- A) Place the machine in override.
- B) Place the scope probe on the yellow wire of the mate & lock connector which wire-or's the signal from the four sensor switches contained within the first box to be diagnosed. (CPU, I/O, MEM 1 and MEM 2).
- C) Block the openings in the top and bottom of each air-flow sensor, in succession, and observe the signal level change on the scope.

cont. next page

COMPANY CONFIDENTIAL

- D) In the I/O and MEM 1 and MEM 2 boxes the signal should take approximately 3 to 5 seconds (or more) before changing levels. When the fingers are removed the signal should go back to it's original level, after some time delay, in a determined fashioned. Those switches which jump immediately when covered or those which wander back when released are most likely marginal and should be replaced. These switches are 110's and the DEC Part # is 12-10756.
- E) In the CPU box the switches are 106's (DEC Part # 12-11608) and are more sensitive. Typically, they will change levels immediately when covered. Again pay close attention to the determined return to original level. Those which return very slowly or wander back are most probably marginal.
- F) After diagnosing a box the probe should be moved to the mate & lock connector of the next box. In this fashion, proceed until all sets of four switches have been tested.
- G) When finished, power down the machine and return the override switch to it's normal position. (The power light should not be blinking).

For both 110's and 106's no description can be given here which is better than the personal observation of their characteristics.

If a replacement switch is not available, the faulty switch can be disabled by removing the yellow wire from that switch.

*****CAUTION*****

By no means should more than one switch within a box be disabled in this fashion.

DUAL PORTED RP04/RP06'S ON TOPS10 VER. 6.03
 BY: CLIFF ROMASH
 NORTHERN CALIFORNIA DISTRICT F.S.

As of 6.03, TOPS10 supports having RP04/6's dual ported between two controllers on the 10. The controllers can be either RH10's or RH20's or one of each. A list of patches necessary to make this work was published in Large Buffer #404. (See list below). In addition to these patches, it is necessary that the drive serial numbers be properly jumpered on the M7776 board in the DCL. This is due to the fact that the monitor detects the fact that a drive is on two controllers by the presence of the same drive serial number (not 0) and drive type on two controllers. Failure to have these properly jumpered can produce various symptoms and/or wipe out disk packs.

cont. next page

COMPANY CONFIDENTIAL

The following is a reprint of the list which appeared in Large Buffer - Volume 404--of all known MCOs concerning drives going offline. These MCOs will be present in 603A.

<u>MCO#</u>	<u>SIRUS PCO#</u>	<u>COMMENT</u>
7141	603 - 010	Short word count/data bus parity errors on RP04s and RH20s
7142	603 - 009	Loop on RP04 PI level on RH20
7143	603 - 008	SYSERR reports zero for all RP04 drive registers on error
7145	603 - 007	Incorrect CHNALL listing from SYSERR
7151	602 - 371	Files get non-zero data where zeros are expected
7180	603 - 012	Confusing error message
7293	603 - 041	Disks offline and RMR errors when swapping on dual ported drives
7303	603 - 044	RMR errors on RP04s only if swapping on RP04
7566	603 - 112	Swapper hung if drive gives on-line interrupt while swapper is busy
7413	603 - 111	Dual ported drive goes offline
7693	603 - 148	RMR error on RP04/RP06s; offline error
7342	603 - 153	Device RPAM offline when dual ported with front end
7297	603 - 152	RMR errors/device offline when swapping on dual ported drive

COMPANY CONFIDENTIAL

OVERTEMP SETTING ADJUSTMENTS ON 857 POWER CONTROL AND ON
858 AUX POWER CONTROL

BY: ROY SEQUEIRA
OTTAWA F/S

Put the main breaker to OFF and unplug J4 on the 857 and J2 on the 858. Put main breaker to ON but do not power up the equipment as the 857 and 858 provide their own power.

Use the accompanying charts to correlate the adjusting pot to the backplane pin.

With a 360 ohm (precision, .1/4 watt) resistor between the backplane pin and ground the overtemp lamp should come on, with a 390 ohm resistor the lamp should stay off.

On the 857, to adjust

K522YA module at	A06	upper pot	use pin	C04D
	A06	lower pot	use pin	C04F
	A07	upper pot	use pin	C04J
	A07	lower pot	use pin	C04L
	A08	upper pot	use pin	C04N
	A08	lower pot	use pin	C04R

On the 858, to adjust

K522YA module at	B06	upper pot	use pin	B05D
	B06	lower pot	use pin	B05F
	B07	upper pot	use pin	B05J
	B07	lower pot	use pin	B05L
	B08	upper pot	use pin	B05N
	B08	lower pot	use pin	B05R

Refer to prints 857-0-TMP and 858-0-LTS for actual schematics.

COMPANY CONFIDENTIAL

Please replace the following sample of the Internal Order Form with the sample order form which appeared in the May/June issue of GOODSTUFF #7. There were errors in that items on the sample Internal Order Form did not coincide with the Model #'s and descriptions outlined in the article itself--Ref.: 3. KLAD PART NUMBERS AND ORDERING PROCEDURES (PAGE 11).

Sorry for the inconvenience.



INTERNAL ORDER FORM

REG. FAC. CODE	BOOK CTR.	D.E.C. NO.
----------------	-----------	------------

NOTE: The actual size of this form has been shortened due to space requirement

REQUESTED BY Jay Random #123456	LOCATION CC 123	EXT. 000	DATE 3-15-78	RESP. PROD. LINE F.S.
------------------------------------	--------------------	-------------	-----------------	--------------------------

E: IN-HOUSE DEMO TRADE-SHOW OTHER Field Service

DELIVER TO: NAME Mr. F.S. Manager - c/o Digital Equipment ADDRESS 123 Digital Blvd. OR DEC City, USA zipcode D.E.C. LOC.	LINE VOLTAGE N/A	LINE FREQ. N/A	REQ. DEL. DATE ASAP	SCH. DEL. DATE ASAP
EQUIP. TO BE RETURNED? <input type="checkbox"/> YES, WHEN? <input checked="" type="checkbox"/> NO			COST CTR.	
TYPE ORDER <input type="checkbox"/> SYSTEM <input type="checkbox"/> ADD-ON <input type="checkbox"/> SPARE		MODEL NO. KL10 SERIAL NO. 2345		TO BE CAPITALIZED? <input type="checkbox"/> YES <input checked="" type="checkbox"/> NO

ON FOR REQUEST KLAD update (or) KLAD replacement

SPECIAL INSTRUCTIONS:

Forward directly to LCG F.S. Product Support - MR1-1/S35
for approval - ATTN.: Product Support Supervisor

ITEM	QTY.	MODEL NO.	DESCRIPTION	P/L CODE	PART. ALLOW.	STANDARD UNIT PRICE	AMOUNT
1.	1	KLAD-10	ZH101 P K Klad System (RP04)	-	-	\$ 589.00	\$ 589.00
	1	KLAD-10	ZH102 P L Klad System (RP06)	-	-	1514.00	1514.00
3.	1	KLAD-20	ZT101 P K Klad System (RP04)	-	-	589.00	589.00
4.	1	KLAD-20	ZT 102 P L Klad System (RP06)	-	-	1514.00	1514.00
5.	1	KLAD-10	ZH100 Klad Update Kit	-	-	100.00	100.00
6.	1	KLAD-20	ZT100 Klad Update Kit	-	-	100.00	100.00
TOTAL							

COST CENTER MANAGER	DATE	P. L. MANAGER FURNISHING EQUIPMENT	DATE
FINANCE	DATE	SCHEDULING RESTRICTION To be completed by SDC	

1. COMPUTER ADMINISTRATION 2. FINANCE 3. PRODUCT LINE 4. ORIGINATOR

COMPANY CONFIDENTIAL

GOODSTUFF INDEX - QTR 1 FY79 ISSUE #8

- NEW EDITOR ANNOUNCEMENT
- RELOCATION OF THE DDC
- LCG MICROFICHE LIBRARY AND VIEWER
- KEEP ALIVE CEASE ON DEC SYSTEM 20'S
- KL10 VOLTAGE MARGINING PROCEDURE AND "SEIGE"
- TU45 FIELD ADJUSTMENT PROCEDURE FOR UNITS USED ON PDP-10 OR PDP-11 NUMBER TU45A-0-5 DTD 23 JUNE
- TROUBLESHOOTING TOPS20 MACHINES
- HOW TO GET DATA ON INTER. EBUS PARITY ERRORS
- LCG TRAINING STRATEGY
- DFDTE FAILURES AT CLOCK RATE 2
- INSTALL OF MB20 ADDON MEMORY
- A KL10 DESIGN DEFICIENCY PROCEDURE
- TOUCH-UPS
- DEC-20 WITH DN20'S - WARNING
- 2050 OVERTEMP
- DUAL PORTED RP04/RP06'S ON TOPS 10 VER. 6.03.
- OVERTEMP SETTING ADJUSTMENT ON 857 POWER CONTROL AND ON 858 AUX POWER CONTROL
- INT. ORDER FORM (CORRECTION)



COMPANY CONFIDENTIAL

Good Stuff

This document contains sensitive information which shall not be disclosed to personnel outside of Digital Equipment Corporation.

This Newsletter is meant as an information document. It's contents are not necessarily Company Policy. It's a means by which LCG Product Support can distribute some tidbits of information to you.

ISSUE NO.9—AUGUST

TU45 M8921/M8928 COMPATIBILITY PROBLEMS

BY: ART O'DONNELL
LCG QUALITY ASSURANCE

FIELD INPUT

We are finding it increasingly apparent that GOODSTUFF is not being supported in the area of Field input (articles, small tidbits, etc.). If you feel you have information which could prove useful to Field Service please submit it to:

Nancie Mitchell
MR1-1/S35

It will then be reviewed and published (if there are no discrepancies).

We need your cooperation in this matter to achieve our goal which is:

GOODSTUFF = A Field Service Newsletter written by Field Service for Field Service.

A problem has been discovered with the M8928 module (TU45 MTA Board) and the M8921 module (TU45 MTA Board) when used together in TU45 tape systems. If the M8928 module appears before the M8921 module on the slave buss, the TU45 containing the M8921 may get data buss parity errors when writing in PE mode.

To correct this problem, the 10 capacitors on the M8928 module located next to the 6 buss connectors J8/J9 must be removed from the circuit.

If you have a TU45 tape system with all M8928, or all M8921 modules on the buss, the problem does not exist. It only appears on mixed systems. Beware when you replace modules, that you inspect the tape system and module you replace to insure, if they are mixed, you remove the caps.

PROBLEM WITH KLAD-20

UPDATE TO REV. 11

BY: HERMAN MILLET
LCG QUALITY ASSURANCE

There is a possibility that you may get "Big Buffer Overflow" messages when you bring in the monitor from a newly rebuilt KLAD-20 at Rev. 11. This is happening because the configuration file is set up to set lines 1 thru 10 to 9600 baud. You can correct this problem by setting all the line speeds to 0 (zero) at initial start-up, then building your configuration file according to your system's requirements. The command is as follows:

"SET TER1-10 SPO"

PREREQUISITE TRAINING

BY: JOHN SWAN
LCG PRODUCT SUPPORT

I know that many Engineers in the Field find it difficult to accomplish their prerequisite training due to pressures of work, scheduling problems, etc. It is becoming increasingly important, however, that the Engineers coming to Marlboro for system and/or option training should have attained a minimum skills level. This level can be attained by prior experience or via a program of courses which are available in the Field for self-study. Examples are the Introduction to PDP11 audio/visual course, Disk Fundamentals, Tape Concepts, and Introduction to Data Communications.

As an alternative to taking these courses in your local Branch Office, recently a study center was set up in PK2 where all of these courses are available and an administrator constantly in attendance. You may want to consider "coming to training" a week early and spending that time in PK2 studying whatever prerequisites you require prior to moving to Marlboro for your formal training.

For further details regarding this study center, please contact Ken Rilley in Maynard at Ext. 3748.

EDITORArt O'Donnell
ASSOC. EDITOR...Nancie Mitchell
EDITORIAL OFFICEMR1-1/S35

GOODSTUFF is published on a
monthly-basis.

COMPANY CONFIDENTIAL

M8538 METERBOARD JUMPERS

BY: HERMAN MILLET
LCG QUALITY ASSURANCE

KL10 Rev's 10A and 10B/2A phased-in non-functional changes to the M8538. As a result we have a mixture of compatible Rev's of this board in the Field today. The two acceptable Module Revision Levels (MRL) are "C" and "D". The primary concern with these boards, is that there are jumpers which must be checked depending on whether the system they are used on is a Model "A" 25 MHZ or Model "B" 30 MHZ system. The jumper information is as follows:

M8538 MRL C

If you have an M8538 at MRL "C"--jumpers W1 and W2 are located between chip locations E53 and E58 and jumpers W3 and W4 are located between chip locations E58 and E63. You can find a visual layout of their locations by referring to the UA drawing, M8533-0-0, sheet 3 of 7, Rev. B, Zone B-6.

The jumpers should be installed as follows:

For Model "A" 25 MHZ System
W4 in - W1, W2 and W3 out.

For Model "B" 30 MHZ System
W1 and W2 in - W3 and W4 out.

A chart with this data can be found on CS drawing, M8538-0-MTR2, Sheet 2 of 6, Rev. B, Zone A-7.

M8538 MRL D

If you have an M8538 at MRL "D"--the jumpers are part of a plug which is in chip location E64. You can locate this plug by referring to UA drawing, M8538-0-0, Sheet 2 of 5, Rev. D, Zone C-6.

The way the plug is designed you can accomplish the conversion of the board from 25 MHZ to 30 MHZ or vice versa, simply by rotating the plug 180 . This information can be found on the CS drawing, M8538-0-MTR2, Sheet 2 of 6, Rev. D, Zone A/B-7/8.

COMPANY CONFIDENTIAL

NEW SYSERR COMMANDS

BY: PAUL BAKER

M.E.G.

We have added two new switches to Version 12 of SYSERR, which will be distributed with Release 3A of the Monitor. They are /BRIEF: and /SEQ:, and are intended to be used in conjunction with each other, but do not have to be. The use of either of these switches will cause the SUMMARY to be suppressed.

BRIEF SWITCH

The BRIEF switch will cause one or two lines to be output for each entry selected by the other switches in the command (e.g.: /ALL /CPUPER /DEV: etc.). The information selected for output is considered to be the most important information in each entry, and will allow the user to scan a large number of entries without having to look through reams of paper. Each entry will consist of a SEQUENCE number, which is the record number of the entry in the error file; the time the entry was recorded; the entry type or device (e.g.: MT100, BUGHLT, KLERR, etc.); and some important information about the entry. Whenever the date changes, at the top of each page, there will be a break in the output containing the date on a separate line. The information will be output across the entire page width, and will be tabbed in if a second line is required for an entry. The format for the BRIEF switch is: /BRIEF:n where only the capital letters need be typed. The "n" argument can be a maximum of 132, and defaults to 72 if no colon or argument is given. The argument tells SYSERR the desired page width, so that it can start new lines at the appropriate places without breaking in the middle of a number.

SEQUENCE SWITCH

The sequence switch is best used after a BRIEF report has been done. It will allow the user to see only the desired entries referenced by the record sequence numbers. Thus, the user can obtain the sequence numbers from the BRIEF report, and then by using the /SEQ switch in conjunction with the /DETAIL switch. The formats for the sequence switch are: /SEQ:n to do one entry, and: /SEQ:(n,m,o,...) to do multiple entries (maximum of 20 numbers). Where "n,m,o" are all the sequence numbers obtained from the BRIEF report.

(cont. next page)

COMPANY CONFIDENTIAL

COMMENTS

We would appreciate any comments about the workings or contents of any of the reports generated by the above switches (i.e.: useless, missing, or incorrect information in a BRIEF entry). Address any comments to:

Paul Baker - c/o MR1-1/S35
200 Forest Street
Marlboro, MA 01752

My DTN phone number is 231-6324. However, we would rather get hard copies of the problem, because it's hard to explain a problem over the phone, and they may be forgotten. You may also send MAIL to <BAKER> on system 2102, or to <IQL-BAKER> on system 2116 in Marlboro.

DESTINATION INFORMATION SHEET

BY: GRAHAM MORLAND
LCG QUALITY ASSURANCE

Have your shipping agents ever had a problem with restricted access, etc., when your new system arrives at the customer site? One way to alleviate this problem is to ensure that the attached form has been filled out and submitted with the MASTER ORDER FORM.

Many Salesman are not aware of this form. Dissemination of this article is one sure way of stopping future problems.

(see next page)

COMPANY CONFIDENTIAL

DECSYSTEM 10/20

DESTINATION INFORMATION SHEET

COMPLETE THIS FORM IN CONJUNCTION WITH EACH ORDER TO ELIMINATE MISUNDERSTANDINGS AND TO DOCUMENT DELIVERY SPECIFICATIONS.

CUSTOMER: _____ P.O. #: _____

DEC #: _____

YES	NO
<input type="checkbox"/>	<input type="checkbox"/>
<input type="checkbox"/>	<input type="checkbox"/>
<input type="checkbox"/>	<input type="checkbox"/>
<input type="checkbox"/>	<input type="checkbox"/>
<input type="checkbox"/>	<input type="checkbox"/>

TRUCK LEVEL PLATFORM?

UNION SHOP?

STAIRS? TOTAL #? _____

ELEVATOR? FLOOR #? _____

UNSKIDDING REQUIRED: AT CUSTOMER SITE?

WIDTH RESTRICTION _____ LENGTH _____ HEIGHT _____

RECEIVING HOURS: _____ A.M. TO _____ P.M.

RIGGING TO BE ARRANGED BY: CUSTOMER

DEC

N/A

CUSTOMER SHIPPING CONTACT _____

TELEPHONE # () _____

EMERGENCY # (HOME) () _____

OTHER PECULIARITIES: _____

BRANCH FIELD SERVICE APPROVAL: _____

LOCAL DEC BRANCH TELEPHONE #: () _____

COMPANY CONFIDENTIAL

NEW SYSERR MANUAL

BY: EMILY SHERRILL
M.E.G.

Several months ago we promised a more complete version of documentation of SYSERR to the field to alleviate some of the confusion regarding the use of and the special features not available in SYSERR. After many months of preparation, data gathering, and hair-pulling, we are pleased to announce the new SYSERR manual exists. It will be available to the Field from SDC on July 30. This manual will replace the pages found in volume 11 of the DECsystem 10 Software Notebooks on SYSERR and the existing TOPS20 Manual entitled ERROR DETECTION, RECOVERY AND REPORTING REFERENCE MANUAL, order number EK-SEDRR-RF-002.

The new manual is entitled TOPS10 and TOPS20 SYSERR MANUAL and the new order number is AA-D533A-TK. The software versions represented in the new manual are as follows:

TOPS10 Monitor:	6.03
DAEMON	: 15(475)
SYSERR	: 10A(555)
TOPS20	: Version 3

It will be approximately 150 pages long and will include examples and diagrams that I believe will be much clearer and easier to understand. The decision to combine both TOPS10 and TOPS20 SYSERR documentation has so far met approval from the Field Service Representatives who have seen the preliminary copies.

The manual is divided into three chapters. The first, Introduction and Overview gives some background and a general explanation of the importance and reasoning behind a program such as SYSERR. It is a large outline of the type of errors that are reported on and possible sources of problems. Chapter 2 deals with the running of SYSERR under a TOPS10 environment and last chapter covers TOPS20. In each chapter we have attempted to show common samples pulled from real SYSERR runs and give a concise explanation of what information is contained in that sample.

The new parts of the manual include a section devoted to KLINIK reports, a section describing the DN64 report, an expanded section on the meaning of the several switches available and a small section devoted to the KS10 (2020) reports. The KS10 section is indeed small at this point but plans are made to expand this section as development of SYSERR on the KS10 increases.

COMPANY CONFIDENTIAL

The Appendix consists of SYSERR Error Messages, TjPS10 ERROR.SYS File Formats, Error File Descriptions for TjPS20, and Assembly Instructions for the SYSERR Package.

Any comments from the Field are welcome and encouraged. We especially want to know of any errors in the documentation, suggested additions, and any problems encountered in interpreting the text and samples. I hope the new TOPS10 and TjPS20 SYSERR MANUAL will provide the information that you may need to utilize SYSERR to its best advantage.

SYSERR VERSION
BY: RAY DRUEKE
M.E.G. - MARLBORO

With LCG supporting two operating systems and several major types of hardware configurations, there has been (and will continue to be) lots of development within SYSERR. This may have caused some confusion as to the correct version to use in the field.

Here are the current and future (short term) versions of SYSERR:

- | | | | |
|---------|---|----------------|---|
| CURRENT | { | TjPS10 6.03 | - SYSERR Version 10A distributed on CUSP TAPE |
| | | TjPS20 Rel. 3 | - SYSERR Version 10 |
| FUTURE | { | TjPS20/KS10 | - SYSERR Version 11 |
| | | TjPS20 Rel. 3A | - SYSERR Version 12 |
| | | TjPS20 Rel. 4 | - SYSERR Version 13 |
| | | TjPS10 7.01 | - SYSERR Version 13 |

As bugs are reported (via SPR's), the bug description and fix will be published here in GJJDSTUFF.

COMPANY CONFIDENTIAL

NEW KL CPU STATUS BLOCK ENTRY FOR SYSERR

BY: TED WJCIK

M.E.G.

Have a hard time finding all the status information in a crashed TOPS-20 system? Well this is your lucky day! Beginning with release 3A of TOPS-20 the operating system will attempt to save a great deal of information for you on every hardware detected failure in the KL10 CPU and RH20 controllers and on every BUGINF, BUGCHK or BUGHLT. It will be saved all in one place and with a handle you can get hold of even in a dead system. The function will be enabled with a new switch in SYSERR, the KLSTAT switch. Please bear in mind that this switch requires OPERATOR privileges and that indiscriminate use of it will flood ERROR.SYS with a great deal of useless information. This switch is not meant to be turned on all the time but is of particular use when troubleshooting an intermittent problem. The use of the switch is as follows:

```
SYSERR<CR>
*/KLSTAT:ON<CR> ;to enable status block gathering
*^C
```

```
SYSERR<CR>
*/KLSTAT:OFF<CR> ;to disable status block gathering
*^C
```

The way to find the status block in a dead system is through locations 110 and 111. Location 110 holds the exec virtual address of the block and 111 holds the physical address. In this way it becomes easy to access the information, examine 111 to get the address of the block and then examine the address to gain access to the data.

WORD#	CONTENTS
0	APRID
1	CONI APR
2	C)NI PI
3	DATAI PAG
4	C)NI PAG
5	UPT LOCATIONS 424 THRU 427
11	RDERA
12	CONI RHO THRU RH7
22	C)NI DTE0 THRU DTE3
26	EPT LOCATIONS 0 THRU 37
66	EPT LOCATIONS 140 thru 177
126	UPT LOCATIONS 500 THRU 503
132	AC BLOCK 6 REGS 0 THRU 3 AND 12
137	AC BLOCK 7 REGS 0 THRU 2
142	START OF SBDIAG DATA

(cont. next page)

COMPANY CONFIDENTIAL

The SBDIAG data area is described as follows:

1st WORD - # of blocks,,offset to first

The data blocks of SBDIAGS is described as follows:

1st WORD - # of words,,controller logical address
2nd WORD SBDIAG FUNCTION 0
3rd WORD SBDIAG FUNCTION 1

In addition to saving the information, T3PS-20 will also attempt to type out a subset of the information on the CTY. The output will look like the following:

CPU STATUS BLOCK FOR BUGHLT,BUGCHK OR BUGINF

ERA = 602000,,004424
CONI APR, = 007740,,000003
CONI PI, = 000000,,000377
CONI PAG, = 000000,,660075
DATAI PAG, = 700100,,000651
AR ARX DATA WORD = 000000,,000000
ID PAGE FAIL WORD = 000000,,000000

SBUS DIAGS

CNTRLR	FNC 0	FNC 1
000000	006000,,000000	036100,,016012
000001	006000,,000000	036100,,016005
000002	006000,,000000	036100,,436012
000003	006000,,000000	036100,,436005

This function will be extended to T3PS-10 in release 7.01 and the information will be gathered for both KI10 and KL10 CPU based systems. A later article will describe the T3PS-10 implementation of this function.

COMPANY CONFIDENTIAL

VERSION 12 OF SYSERR

BY: RAY DRUEKE

M.E.G.

Version 12 of SYSERR is in LOAD TEST and FIELD TEST for release with TOPS20 Release 3A. It is currently scheduled to be available from the SDC on or about October 15, 1978. It will also be on the TOPS20 tape sent to all TOPS20 sites. Several new reports and options are included and are summarized here:

1. Support for 2060 configuration--this means support for greater than 4 RH20's (8 max) as well as MF20 (MJS) memory.
2. Support for DX20/TX02/TU70 tape subsystems.
3. Support for the following NETWORK events:
 - a) NETCON Start-Up
 - b) NODE Down-Line Load
 - c) NODE Up-Line Dump
 - d) Line Statistics
4. Re-ordered the KLERROR listing to get the major error signals listed at the top of the signal list. This was requested by the DDC.
5. Support for a KL CPU block requested by the Flying Squad. This report snapshots most of the KL, DTE, and RH20, status register contents and several memory and AC contents. For details see a separate article in this issue.
6. Fix reported bugs.
7. Support for /BRIEF and /SEQ for all TOPS20 reports. For a complete description see a separate article in this issue.

COMPANY CONFIDENTIAL

GOODSTUFF INDEX - QTR. 1 FY79

ISSUE #9

- FIELD INPUT
- TU45 M8921/M8928 COMPATIBILITY PROBLEMS
- PROBLEM WITH KLAD20 UPDATE TO REV. 11
- PREREQUISITE TRAINING
- M8538 METERBOARD JUMPERS
- NEW SYSERR COMMANDS
- DESTINATION INFORMATION SHEET
- NEW SYSERR MANUAL
- SYSERR VERSION
- NEW KL CPU STATUS BLOCK ENTRY FOR SYSERR
- VERSION 12 OF SYSERR

DFDXC. Ver 0

041641 /

add

260740, 44322

new

260740, 76112

76112 /

add
all 0

260740, 44322

76113 /

260740 44322

76114

263740, 0-0's

Rev B ECO to RH20

cause 2 done sig type

backlog when doing wireless

board a diag.

Break Test 145 data x for test.

Good Stuff

This document contains sensitive information which shall not be disclosed to personnel outside of Digital Equipment Corporation.

This Newsletter is meant as an information document. It's contents are not necessarily Company Policy. It's a means by which LCG Product Support can distribute some tidbits of information to you.

ISSUE NO.10 — SEPTEMBER-F.Y.79

DGKBB V1.10

BY: SEAN KEENAN
DDC 10/20

In a recent diagnostic session test 30 subtest 1 of DGKBB V1.10 failed. After printing our actual and expected data it got a message - undef. Trap at PC 70022? fatal halt at 50574.

Upon further investigation I found that two new macro's for loadac and the traps created were not added to the trap table in the diagnostic. If the following addresses are changed the diagnostic at that test will run giving isolation for the failure.

ADDRESS	DATA
51024	60744
51026	60732

CAN'T GET THAT MANUAL

BY: JOHN SWAN
LCG PRODUCT SUPPORT - TOOLS

In Issue No. 7 of Goodstuff we published a list of manuals which are available in hard copy format. Unfortunately, one of these manuals is undergoing revision and therefore is not yet on the shelf.

It is:

DEC20 INSTALLATION PROCEDURES
EK-20XX-IN-PRE

As soon as it is available, I will let you know.

PART NUMBER

BY: BILL HILLIARD
LCG PRODUCT SUPPORT

The part number for KL10 CPU Clock Coax Wire is: 17-00039.

COMPANY CONFIDENTIAL

EXERCISING THE ELECTRONIC FINGER

BY: LINC KRAEUTER
LCG TRAINING

Existing diagnostic programs DFSXA and DFDTE do not specifically localize failures in the electronic finger circuit; these diagnostics simply indicate a bus time out. Dwayne Moore and Ray Spence of the Portland Field Office have solved this problem by using a CONO command to switch the KL10 electronic finger on and off.

Operating under KLDCP they first called in KLDDT:

>.P KLDDT ESC

Now under KLDDT they execute a CONO instruction directed to DTE logical 1.

CONO 204.14000 ESC X

The CONO presents a high to both the J and the K inputs of the JK flop as well as a clocking pulse. The HI on both J and K causes the JK flop to toggle to the opposite state.

If the circuit is operational a -2 volt (on) or a +4.5 volt (off) signal results on the electronic finger cable.

SEE DIAGRAM NEXT PAGE →

EDITORArt O'Donnell
ASSOC. EDITOR...Nancie Mitchell ✓
EDITORIAL OFFICEMR1-1/S35

GOODSTUFF is published on a
monthly-basis.

Copyright © 1978, Digital Equipment Corporation

The driving circuit is located in the KL10 DTE: Ref. KL10-C/Vol 2

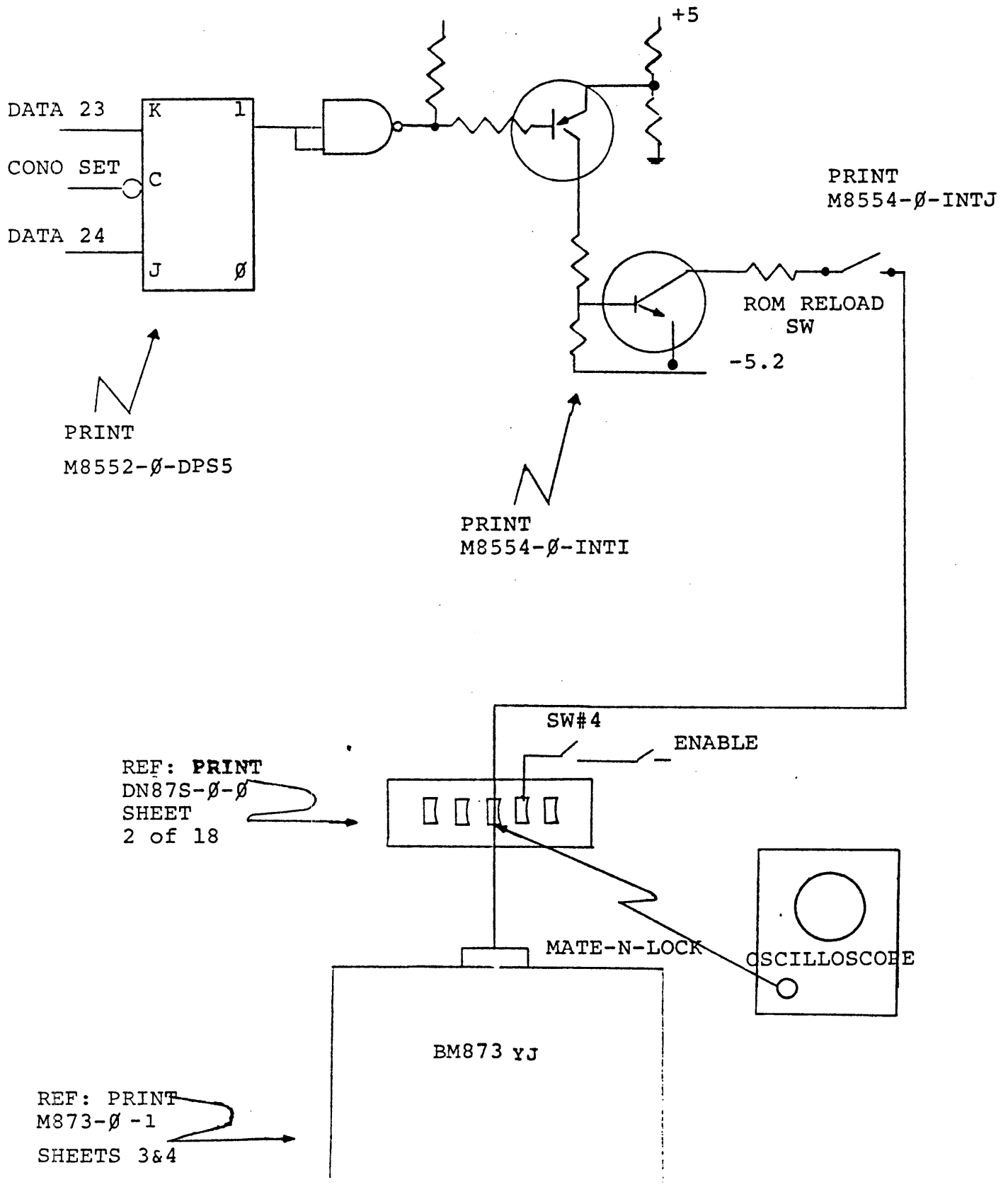

COMPANY CONFIDENTIAL

WIRE WRAP/BACKPANEL INFORMATION AND HOW TO USE THE MICROFICHE

BY: STEVE WESTON
LCG PRODUCT SUPPORT

I. PURPOSE

This document attempts to explain the various headings and nomenclature used in the wire wrap listings. These listings can be found in the microfiche library on the fiche with a yellow banner. There are three types of listings you will be concerned with. They are the pin sort, the name sort, and the from-to-sort. Also, Section 3 provides some general information on KL10 CPU backpanels.

II. Description of "SORTS"

A. Pin Sort

The pin sort is used when you have a pin and are looking for the signal name associated with that pin. This listing is organized in alphanumeric order starting with pin 4A01A1 and ending with pin 4F54P1. The number designation 4 in 4A01A1 means CPU KL10. Other possible numerical prefixes include:

- 1 = DMA/DIA
- 2 = RH/DTE (DTE)
- 3 = MEM (Internal 20's)
- 4 = CPU KL10

The headings of interest in the pin sort include run name, A/P, and pin name. They are defined as follows:

Run Name = signal name
A/P = signal logic level

e.g.: H = high
-H = low
G = ground

Pin Name = pin name

CONT. NEXT PAGE →

COMPANY CONFIDENTIAL

B. Name Sort

The name sort is used when you have the signal name and are looking for all the pins in the signal run. This listing is also organized in alphanumeric order. It starts with run name #00 and ends with WRITEBACK T2-H.

The headings of interest in the name sort include run name, A/P, pin name, Q, draw, module type, and flag. They are defined as follows:

Run Name = signal name
A/P = signal logic level
Pin Name = pin name
Q = wire type (see note *)

e.g.: H = TWP
P = etch
D = differential TWP (RH/DTE20)
K = special straight hand wires
B = bus bar

Draw = drawing signal appears on
Module Type = type module the associated
pin is used on.
Flag = type of signal

e.g.: S = Source
T = Termination
C = Cable
O = Output (similar to "source" but
treated special by wire list
program).
+ = Source +3V
G = Ground source

* NOTE: THE FIRST THREE (H,P,D,) WILL BE FOUND IN KL'S. OTHERS ARE FOUND IN OTHER OPTIONS AND ARE STATED FOR GENERAL KNOWLEDGE. ALL OTHER DESIGNATIONS ARE MEANINGLESS AND ARE JUST TRANSFERRED OVER FROM THE "FLAG" COLUMN BY THE WIRE WRAP PROGRAM. GENERALLY, THE LAST PIN IN THE "Q" COLUMN WILL BE A "T".

CONT. NEXT PAGE →

COMPANY CONFIDENTIAL

The following example should serve to illustrate the use of each column in the listing:

EXAMPLE:

<u>RUN NAME</u>	<u>A/P</u>	<u>PIN NAME</u>	<u>Q</u>
EBUS D27E	H	4B04F2	H
		4C22J1	H
		4E23L2	H
		4D33J1	P
		4D36T2	O
		4D38S1	P
		4D42P1	P
		4D41P1	T

The run is listed exactly as it would be found wired in the machine. The entry would be interpreted as follows:

4B04F2	TWP	to	4C22J1
4C22J1	TWP	to	4E23L2
4E23L2	TWP	to	4D33J1
4D33J1	ETCH	to	4D36T2
4D36T2	STRAIGHT WIRE	to	4D38S1 **
4D38S1	ETCH	to	4D42P1
4D42P1	ETCH	to	4D41P1

** The "O" was carried over from the "FLAG" column and is meaningless. However, because the "Q" column was empty, I assumed this wire was straight and not special. There is no letter to identify straight wires that are not special.

A word of Wisdom: Etch can be on pin side or block side of etch backplane.

C. From to Sort

The from to sort is used to find ground wires when you have the signal pin and need to replace a wire. The title is misleading!!! It is not a from to list!!! It is a list of associated wires, signal and ground or ground and signal.

The headings of interest in the from to sort include from, to, and G.D. card sequence. They are defined as follows:

From	= one wire of TWP
To	= other wire of TWP
G.D. Card Sequence	= in what order wire was wrapped.

CONT. NEXT PAGE →

The following example illustrates the use of the from to sort:

<u>FROM</u>	<u>TO</u>	<u>G.D. SEQUENCE</u>
C22J1	C23H1	1188
C22J1	C23H1	4041

Sequence # indicates 1188 is on the bottom because it was put on before 4041. (Bottom is defined as closest wrap to etch board also referred to as Z1). If we were to replace C22J1 - C23H1 (4041), we would go to C23H1 on the from to sort listings and find three wires on the pin, sequence #1188, 4041, and 2573:

<u>FROM</u>	<u>TO</u>	<u>G.D. SEQUENCE</u>
C23H1	C22J1	1188
C23H1	C22J1	4041
C23H1	C22L1	2573

1188 is on the bottom (Z1), 2573 is in the middle (Z2), and 4041 is on top (Z3). When three wires appear on a pin in the listing, it will always be a ground pin. Two wires on a pin can be either signal or ground. However, you already know the signal pin and you are looking for ground.

If we were to remove C22J1 - C23H1 (1188), we would have to remove all the ground and signal wires and replace them all. To find these wires, you must use pin sort C22J1, to name sort EBUS D27 E to find pin B04F2 or E23L2, and back to the "from to" to find their grounds.

III. GENERAL BACKPANEL INFORMATION

The backpanel is constructed in etched layers separated by epoxy board for insulation. The construction of the backpanel is as follows:

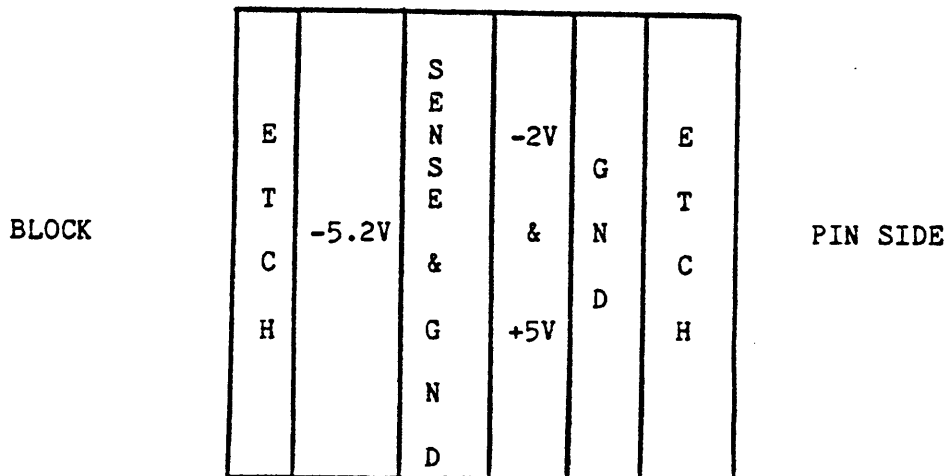

COMPANY CONFIDENTIAL

MA20M/MB20M MEMORY PROBLEMS

BY: ART O'DONNELL/HERMAN MILLET
LCG QUALITY ASSURANCE

LCG Engineering has discovered a serious design problem with MA20M/MB20M memories used on DEC System 20's and 1091's (Internal Memory only).

The problem is most frequently seen as memory parity errors when running internal memory 2-way interleaved on systems that contain DN20 communications subsystems. However, this is only the most common failure mode, other system configurations may cause DEX errors; or parity errors. Therefore, LCG Product Support is authorizing and strongly recommending that you install the following pre-release Field Change in all M8561 and M8568 memory controller modules in your systems and spares as soon as possible.

MA20M

The minimum acceptable revision level of this board in the Field today is Rev "C".

Rework from Rev. C to Rev. D

- Step 1: Cut etch side two at E74 between pins 4 & 5.
- Step 2: Add wire side one at E74 pin 4 to PTH below E74 pin 8.
- Step 3: Update Brady Marker from Rev. C to D.

To verify the M8561 - MA20M REWORK:

1. Use an OHM meter and check for no continuity between E91 pin 15 and E74 pin 5. This verifies the etch cut.
2. Check for continuity between E91 pin 15 and E74 pin 4. This verifies the wire add. The signal name affected is: MAC3 BUSY H to pin 4 of E74.

CONT. NEXT PAGE →

MB20M

Rework from Rev. A to Rev. B

- Step 1: Cut etch side two at E75 between pins 4 & 5.
- Step 2: Add wire side one at E75 pin 4 to PTH above C-75.
- Step 3: Update Brady Marker from Rev. A to B.

To verify the M8568 - MB20M REWORK:

- 1. Use an OHM meter and check for no continuity between E92 pin 15 and E75 pin 5. This verifies the etch cut.
- 2. Check for continuity between E92 pin 15 and E75 pin 4. This verifies the wire add. The signal name affected is: MAC3 BUSY H to pin 4 of E75.

The above Field Change will be processed as part of KL Rev. 12/4. They will be formally documented at that time. Also, on the following four-pages you will find an enlarged set of UA prints for the modules affected.

CONT. NEXT FOUR PAGES →

E66

E71

E76

E80

E85

E9

MA20M - M8561

CUT ETCH SIDE TWO AT E74
BETWEEN PINS 4 & 5.

CUT

(8)

CUT

(9)

CUT

(15)

CUT

(11)

(12)

CUT

MA20M - M8561

ADD WIRE SIDE ONE AT E74
PIN 4 TO PTH BELOW E74

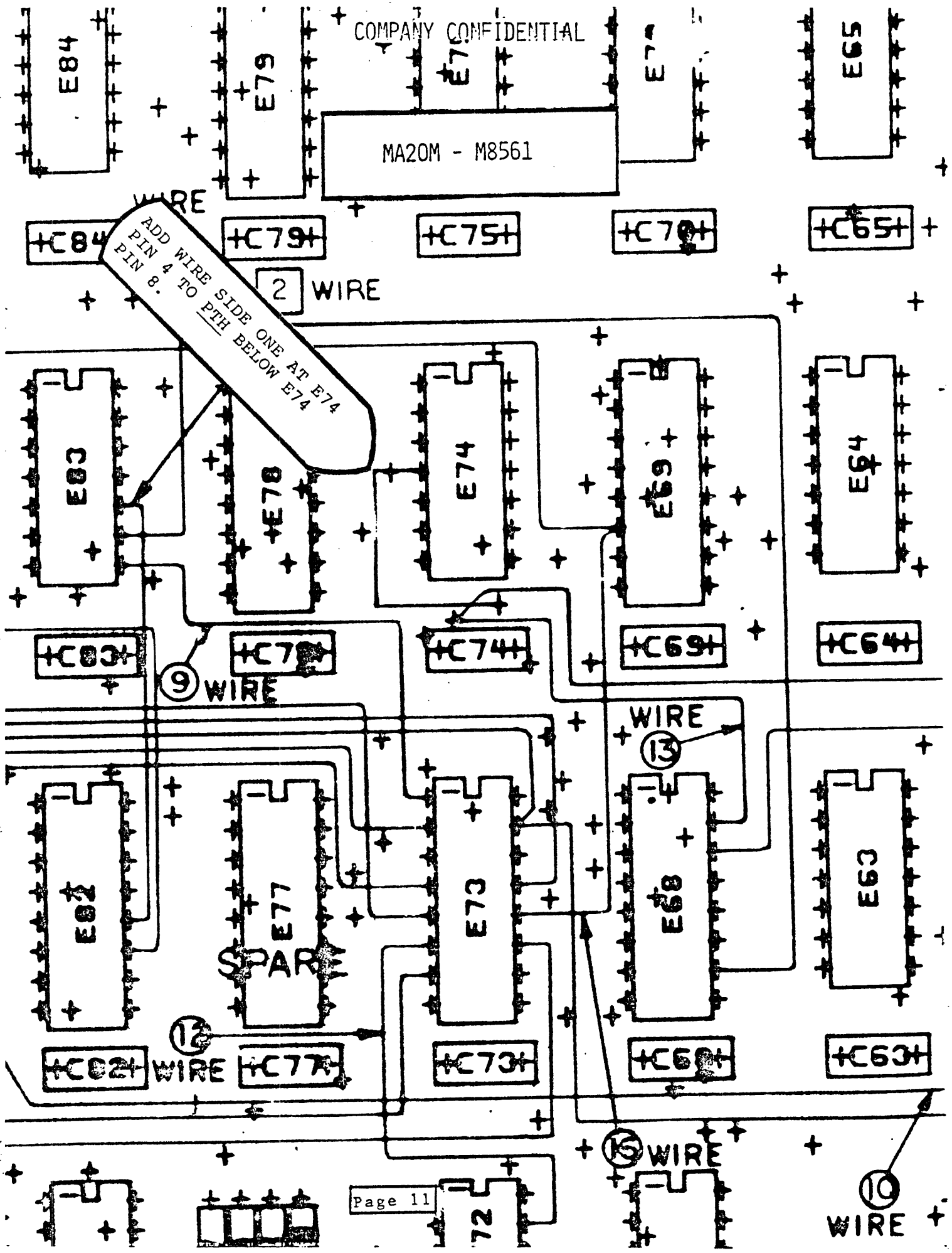

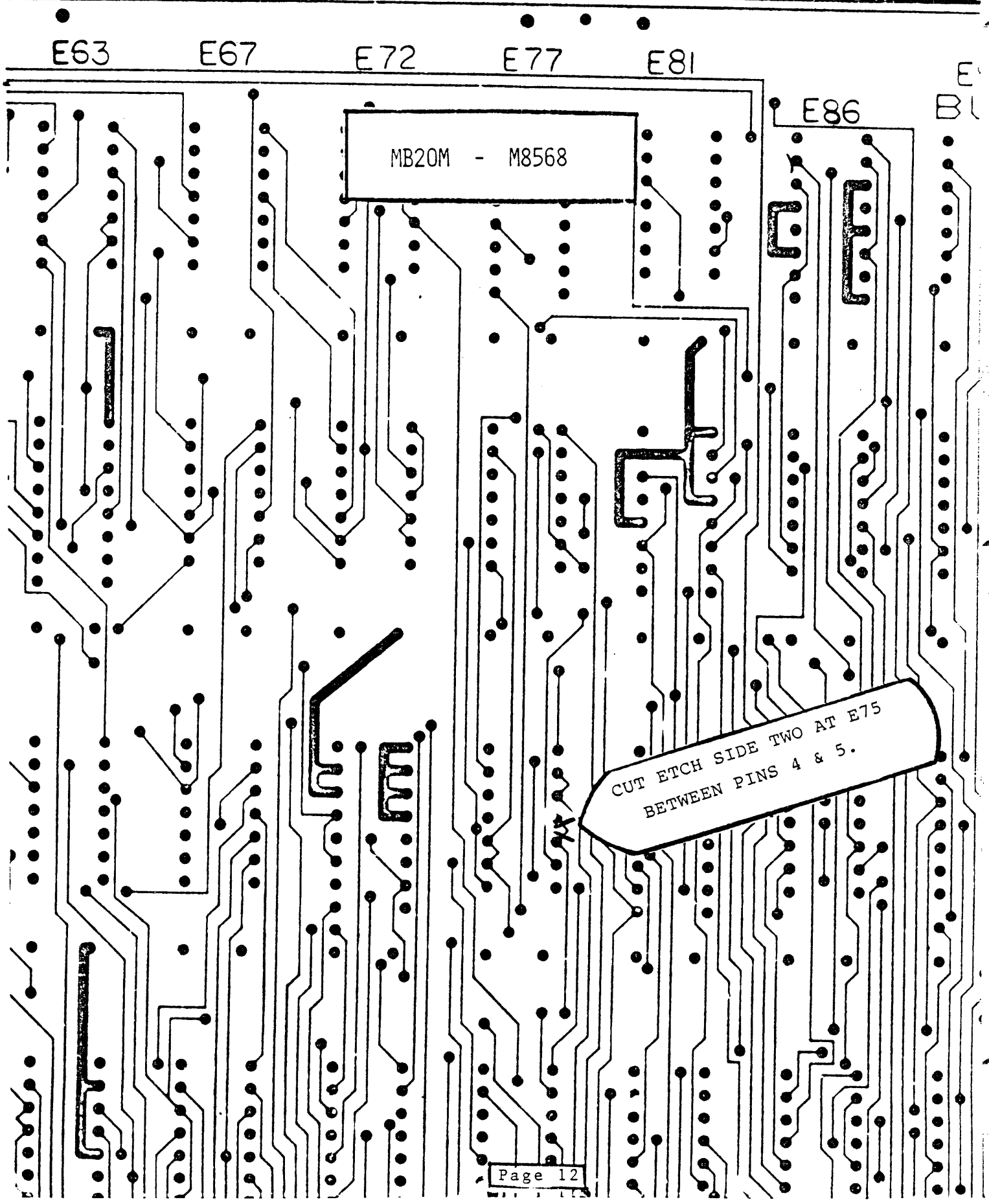

MB20M - M8568

CUT ETCH SIDE TWO AT E75
BETWEEN PINS 4 & 5.

MB20M - M8568

ADD WIRE SIDE ONE AT E75
PIN 4 TO PTH ABOVE C 75.

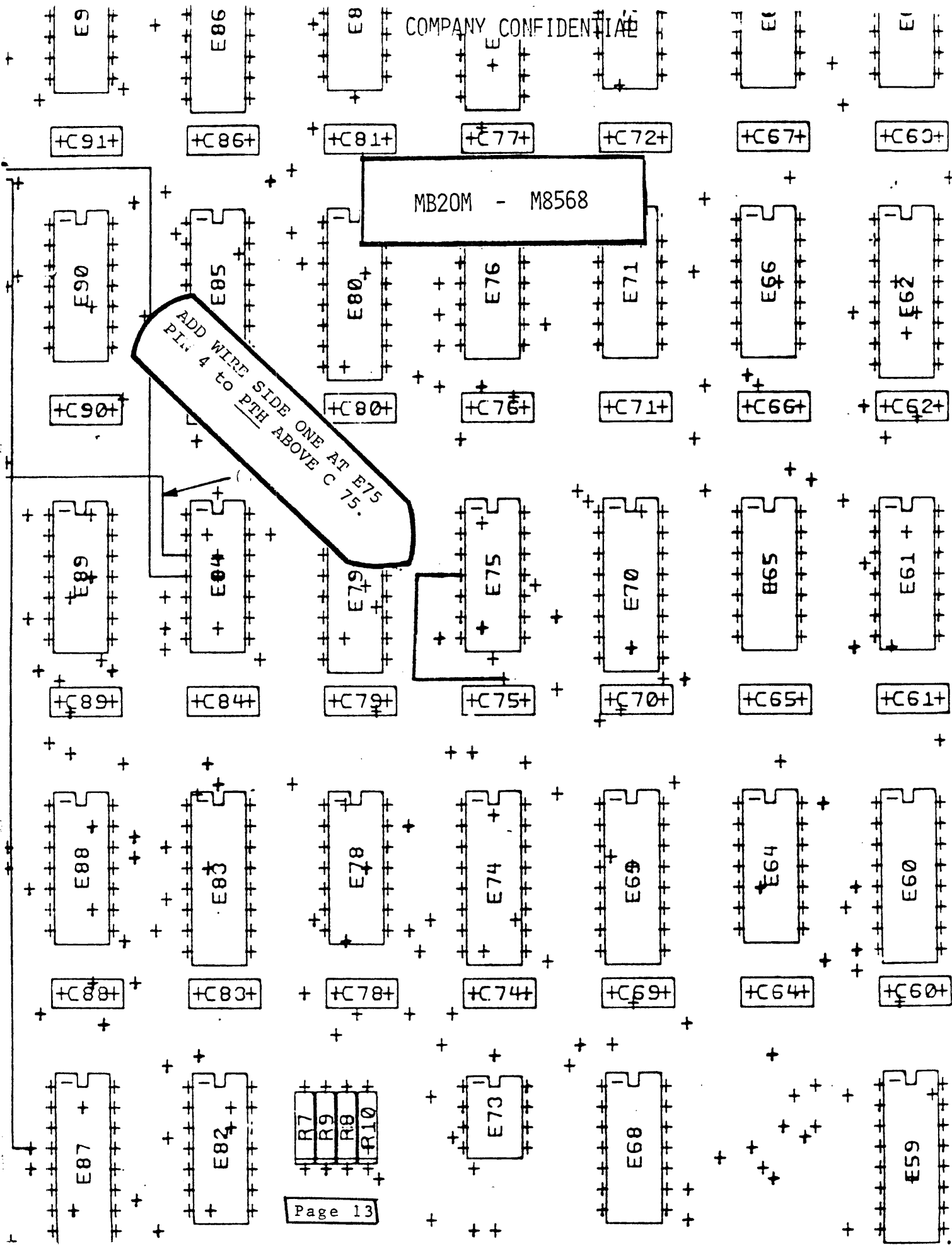

KL/KS FEEDBACK FORMS FOR INSTALLATION AND ACCEPTANCE

BY: GRAHAM MORLAND
LCG QUALITY ASSURANCE

Beginning the week ending August 19, 1978, LCG Quality Assurance has begun distribution of the following forms as part of LCG's drive to measure and quantify systems quality.

Upon completion of Manufacturing acceptance a duplicate of the enclosed package will be mailed to the appropriate Branch Field Manager responsible for the system installation. These forms will have Branch/System/Customer information entered prior to delivery and have a pre-typed return address. For those of you involved in installations and acceptance, your help in making this project effective will be greatly appreciated.

CONT. NEXT THREE PAGES →

LCG MANUFACTURING AND LCG PRODUCT SUPPORT HAVE EMBARKED ON A JOINT PROJECT TO FURTHER IMPROVE THE QUALITY OF LCG'S SYSTEMS.

ON MANUFACTURINGS PART THEY HAVE TIGHTENED THEIR SYSTEMS ACCEPTANCE CRITERIA, STARTING JULY 1ST, 1978, FOR BOTH KL AND KS BASED SYSTEMS. THEY WILL ALSO BE USING AN IMPROVED MEASUREMENT SYSTEM IN THE PLANT FOR THEIR QUALITY YIELDS.

PRODUCT SUPPORT HAS BEEN ASKED TO MONITOR ALL LCG SYSTEM INSTALLATIONS CLOSELY OVER THE NEXT SIX-MONTHS, TO MEASURE SYSTEMS QUALITY FROM INSTALLATION TO END OF WARRANTY.

WE WILL OF COURSE BE USING LARS FOR SOME OF THIS ACTIVITY BUT ARE REQUESTING THAT YOU TAKE THE TIME TO FILL IN THE ATTACHED FEEDBACK FORMS TO ASSIST US IN A COMPLETE ANALYSIS. YOUR PARTICIPATION WILL HAVE A DIRECT INFLUENCE ON THE QUALITY OF FUTURE LCG SYSTEMS. THIS DATA WILL BE FED BACK TO MANUFACTURING AND ENGINEERING AND WILL PRODUCE RESOLUTIONS.

IT IS IMPORTANT THAT THE 72-HOUR KLAD ACCEPTANCE (OR EQUIVALENT) IS RUN FOR KL BASED SYSTEMS AND THAT UETP (USER ENVIRONMENTAL TEST PACKAGE) IS RUN FOR 48-HOURS ON KS BASED SYSTEMS. (SEE SHEET 2). THIS WILL BE A PRIME FACTOR IN MEASURING THE QUALITY OF PRODUCTS SHIPPED OUT OF MARLBORO.

NOTE: SHEET 1 -- PLEASE RETURN THIS FORM IMMEDIATELY UPON RECEIPT OF SYSTEM.

SHEET 2 -- PLEASE RETURN THIS FORM UPON COMPLETION OF INSTALLATION AND HARDWARE ACCEPTANCE OF SYSTEM.

THANKS IN ADVANCE FOR YOUR COOPERATION IN THIS MATTER.

COMPANY CONFIDENTIAL

SHEET 1

PRE-INSTALLATION REPORT

SERIAL #:	_____
CUSTOMER:	_____
DEC #:	_____
SYSTEM TYPE:	_____
BRANCH C.C.:	_____

RECEIPT:

YES NO

- 1) FULL SHIPMENT
- 2) DAMAGE
- 3) MICROFICHE RECEIVED AT BRANCH
- 4) SPARES RECEIVED
- 5) NOTIFIED: (VIA TWX)

MOF	BLUE LINE	72 HOUR	SHIP
<input type="checkbox"/>	<input type="checkbox"/>	<input type="checkbox"/>	<input type="checkbox"/>

6) SCHEDULED INSTALLATION DATE: _____

COMMENTS:

MANAGER/SUPERVISOR SIGNATURE

DATE

COMPANY CONFIDENTIAL

SHEET 2

INSTALLATION AND ACCEPTANCE REPORT

CUSTOMER: _____ SER.#: _____ SYSTEM TYPE: _____
 LOC./CC: _____ PREPARED BY: _____ TELE #: _____
 DELIVERY DATE: _____ INST. DATE: _____ INST. FINISH: _____
 INST. HOURS: _____ SYSTEM REV. LEVEL: _____

INSTALLATION

CONDITION OF SYSTEM: GOOD ___ FAIR ___ POOR ___

	NO	YES		NO	YES
1) SITE PREP INCOMPLETE:			11) VOLTAGE ADJ. NEEDED:		
2) SHIPPING DAMAGE:			12) INCORRECT DIAGNOSTIC VERSIONS:		
3) PACKING DAMAGE:			13) ERRORS DURING DIAG. RUN:		
4) PAPERWORK INCOMPLETE:			14) HARDWARE PROBLEMS:		
5) DOCUMENTATION INCOMPLETE:			15) PROBLEMS UNDETECTED BY DIAGNOSTICS:		
6) ACCESSORIES INCOMPLETE:			16) ADJUSTMENT PROBLEMS:		
7) HARDWARE INCOMPLETE:			17) SOFTWARE PROBLEMS:		
8) SYSTEM INTERCONNECTION PROBLEMS:			18) ENVIRONMENTAL PROBLEMS:		
9) PRE-POWER PROBLEMS:			19) D.O.A. SPARES:		
10) POWER-UP PROBLEMS:					

IF YOU HAVE ANSWERED "YES" TO ANY OF THE ABOVE QUESTIONS--PLEASE DESCRIBE BRIEFLY ON THE FOLLOWING PAGE.

HARDWARE ACCEPTANCE

DEFINITIONS: KL-BASED SYSTEMS: RUN 72-HOUR KLAD ACCEPTANCE FILE (OR EQUIVALENT)
KS-BASED SYSTEMS: RUN 48-HOURS USER ENVIRONMENTAL TEST PACKAGE.

- A) START TIME -- DATE: _____
- B) FINISH TIME -- DATE: _____
- C) # OF CRASHES/RETRIES: _____
- D) HOURS ACCEPTANCE: _____
- E) PROBLEM DESCRIPTION (IF ANY): _____

COMPANY CONFIDENTIAL

STOP CODE LIST BY: TED WOJCIK M.E.G.

Have a hard time finding out about those funny stopcodes your system has been hitting? Well, look no further!! The following list contains all known stopcodes in 6.03. This list was extracted from the sources for 6.03 and sorted alphabetically. In addition to the stopcode name you will find listed the monitor module it lives in, the type of stopcode it is (HALT,STOP,DEBUG,JOB) and as much comment as the programmer thought fit to put with it.

The four kinds of stopcode HALT, STOP, DEBUG and JOB act differently in different circumstances and below you will find a description of their actions and the circumstances which modify the actions.

DEBUG - if a priority interrupt is in progress, the condition is not immediately harmful to the system or any job. The monitor types out a message on the CTY and continues. If no priority interrupt is in progress, a DEBUG stopcode acts the same as a JOB stopcode.

JOB - if no priority interrupt is in progress the condition jeopardizes the integrity of the current job. The monitor sends a message to both the CTY and the user's terminal and aborts the job. If a priority interrupt is in progress then a JOB stopcode acts like a STOP stopcode.

STOP - This condition jeopardizes the integrity of the entire system. The monitor sends a message to the CTY and aborts all jobs and reloads the system.

HALT - This condition is so serious that the monitor is not going to do anything that might affect stored data. The system executes a HALT instruction and waits for the operator to initiate a reload.

SEE NEXT SIX PAGES →

COMPANY CONFIDENTIAL

<u>MONITOR</u> <u>MODULE</u>	<u>STOPCD</u> <u>NAME</u>	<u>STOPCD</u> <u>TYPE</u>	<u>COMMENT</u>
XTCSER	28B	DEBUG	DA28 IS BROKEN
FSXKON	4IF	DEBUG	RS04 ISN'T FANCY
D85INT	5WE	DEBUG	DC75 WRONG PDP11 CODE
D6SINT	6DD	DEBUG	11 GAVE TOO MUCH DIRECT DATA
D6SINT	6DI	DEBUG	UNEXPECTED TO-10 DONE INTERRUPT
D6SINT	6ID	DEBUG	11 GAVE TOO MUCH INDIRECT DATA
D76INT	6MS	DEBUG	DC76 MESSAGE IS SHORT
D76INT	6QF	DEBUG	DC76 QUEUE FULL
D78INT	8BI	JOB	??????????????
D78INT	8IN	JOB	INPUT CHAR CNT NOT = TO 0
D78INT	8NC	JOB	NOT ENOUGH MONITOR FREE CORE
D78INT	8ON	JOB	OUTPUT CHAR CNT NOT = TO 0
D78INT	8PI	JOB	POSITIVE IOWD
D60INT	8VI	DEBUG	DN60 WRONG PDP11 CODE
D78INT	8VI	DEBUG	VERSION INCORRECT
FILFND	AAD	DEBUG	A. T. ALREADY DORMANT
KISER	AAO	JOB	ACCESS ALLOWED OFF
KLSEK	AAO	JOB	ACCESS ALLOWED OFF
COMMON	AD#	STOP	CPU N ADDRESS PARITY ERROR
FILFND	AES	JOB	ABNORMAL END OF SEARCH LIST
FILIO	AHB	DEBUG	ALREADY HAVE BUFFER
ONCMOD	AHS	HALT	ALREADY HAVE STRUCTURE
FILFND	AOC	DEBUG	ALREADY OWN CB
VMSEK	APF	DEBUG	ALLOCATED PAGE FREE
ONCMOD	AR1	DEBUG	ASKDEC RETURNED CPOPJ1
DTESEK	ARD	STOP	RUNAWAY DRIVER
KISER	ARF	STOP	ATTEMPT TO RETURN FREE PAGE
KLSEK	ARF	STOP	ATTEMPT TO RETURN FREE PAGE
FILFND	ARM	DEBUG	ACCESS RINGS ALL MESSED UP
DTESEK	BAA	STOP	BUFFER ALREADY THERE
CORE1	BAC	DEBUG	BIT ALREADY CLEAR
FILFND	BAD	JOB	BLOCK ALREADY DORMANT
FILIO	BAO	DEBUG	BIT ALREADY ONE
FILIO	BAZ	DEBUG	BIT ALREADY ZERO
DTESEK	BDN	STOP	BAD DEVICE NUMBER
TAPUO	BFO	DEBUG.	BETTER FIND ONE
NETSEK	BFU	DEBUG	BUSY FOULED UP
FILIO	BIN	STOP	IO TO A NEGATIVE BLOCK
FILUO	BMR	JOB	BLOCK MISSING FROM RIB
COMMON	BNF	HALT	BOOTS NOT FOUND
FILUO	BNR	JOB	BLOCK NOT RIB
FILFND	BNT	DEBUG	BLOCK NOT THERE
CORE1	BNZ	DEBUG	BIT NOT ZERO
CP1SEK	BPS	HALT	BOTH PROCESSORS STOPPED
COMCON	BRC	DEBUG	BAD RETURN FROM CMPBIT
SEGCON	BSN	STOP	BAD SEGMENT NUMBER
XTCSER	BSY	DEBUG	DA28 BUSY
FILIO	BWA	JOB	BLOCK WENT AWAY
COMMON	C#P	DEBUG	CPU N POWER FAILED?
CP1SEK	C1N	DEBUG	CPU 1 NXM
FILUO	CAO	DEBUG	CLUSTER ADDRESS ODD
REFSTR	CAS	HALT	COULDN'T ALLOCATE SPACE
COMMON	CD#	STOP	CPU N CACHE DIR PARITY ERROR
FILIO	CDA	DEBUG	IN CORE COPY DOESN'T AGREE
MSGSEK	CDD	JOB	CAN'T DISCONNECT DEVICE
CLOCK1	CFP	JOB	CANT FIND PDB
ONCMOD	CGS	HALT	CAN'T GET STR DATA BLOCK

COMPANY CONFIDENTIAL

FHXKON	CIF	DEBUG	RC10 ISN'T FANCY
REFSTR	CIO	DEBUG	CFP IS ODD
SCNSER	CLO	STOP	CHUNK LINKS TO ZERO
FILFND	CME	DEBUG	CFP MODULO ERROR
VM SER	CMS	DEBUG	CORE1 MUST SKIP
SEGCON	CMU	STOP	CORE MESSED UP
SCHED1	CNA	STOP	CORE NOT AVAILABLE
FILUOO	CNE	DEBUG	CLUSTER NOT EVEN
FILUOO	CNF	DEBUG	IN CORE COPY NOT FOUND
KILOCK	CRW	STOP	CA RESOURCE WRONG
COMCON	CSA	DEBUG	CANT SET ACCESS ALLOWED
FILIO	CSE	STOP	CHECKSUM ERROR
SEGCON	CSP	JOB	CANNOT STORE PATH
NETSER	CWN	DEBUG	CORE ALLOCATION WENT NEGATIVE
FILIO	DBZ	DEBUG	DEPLPC BIT ZERO
FILUOO	DCR	DEBUG	DELTRIB CPOPJ RETURN
FILUOO	DDS	DEBUG	DELTRIB DIDN'T SKIP
FILUOO	DER	DEBUG	DELTRIB ERROR RETURN
COMNET	DFU	DEBUG	DEVICE UNRECOGNIZED
FILIO	DHA	DEBUG	DON'T HAVE AU
FILIO	DHB	DEBUG	DON'T HAVE BUFFER
FILIO	DHD	DEBUG	DON'T HAVE DA
FILIO	DND	DEBUG	DRIVE NOT DUAL PORTED
DTESER	DNE	STOP	COUNT NOT EVEN
FILUOO	DNF	DEBUG	DDB NOT FOUND
DTESER	DNH	STOP	DRIVER NOT HUNGRY
DTESER	DNI	STOP	DTE NOT READY
FILUOO	DNR	DEBUG	DELTRIB NON-SKIP RETURN
FILUOO	DNS	DEBUG	DELTRIB NON-SKIP RETURN
COMCON	DPL	DEBUG	DIRECTORY PAGE LOST
COMCON	DPN	DEBUG	DIRECTORY PAGE NON-EXISTANT
VM SER	DSS	DEBUG	DLTSP SKIPPED
DTESER	EFI	STOP	ILLEGAL FUNCTION CODE
ERRCON	EPO	DEBUG	EXEC PDL OVERFLOW
REFSTR	ERB	DEBUG	ERROR READING BAT BLOCK
ONCMOD	ERD	DEBUG	ERROR REFRESHING DISK
TAPSER	ERF	STOP	ERP REALLY FOULED UP
REFSTR	ERH	DEBUG	ERROR READING HOME.SYS
ONCMOD	ERM	DEBUG	ERROR READING MFD
REFSTR	ERP	HALT	TOO MANY RETRIEVAL PTRS
ONCMOD	ERS	DEBUG	ERROR READING SAT
FILFND	ESS	JOB	EMPTY SYSTEM SEARCH LIST
ERRCON	EUE	DEBUG	EXEC UO ERROR
REFSTR	EWB	DEBUG	ERROR WRITING BLOCK
REFSTR	EWH	DEBUG	ERROR WRITING HOME BLOCKS
ONCMOD	EWR	DEBUG	ERROR WHILE REFRESHING
FILUOO	FAD	DEBUG	FILE ALREADY DORMANT
VM SER	FCZ	DEBUG	FUNNY CORE BIT ZERO
FILIO	FDP	DEBUG	FIXED HEAD DEVICE POSITIONED
NETSER	FFU	STOP	F FOULED UP
VM SER	FIP	DEBUG	FREE-PAGE IN USE
SCNSER	FLE	STOP	FREE LIST EMPTY
DTESER	FNG	STOP	ILLEGAL FUNTION CODE
KILOCK	FPF	STOP	PAGE ON FREE LIST ISN'T FREE
KISER	FPI	STOP	FREE PAGE IN USE
KL SER	FPI	STOP	FREE PAGE IN USE
KILOCK	FPN	STOP	FREE PAGE NOT FOUND
REFSTR	HBE	DEBUG	ERROR READING HOME BLOCKS
XTCSER	HDS	STOP	?????????
FILIO	HIF	DEBUG	HOLE IN FILE

COMPANY CONFIDENTIAL

ONCE	HNF	HALT	HI SEG NOT FOUND
FILIO	HWU	JOB	HARD WRONG UNIT
CLOCK1	IBI	JOB	INTERCEPT BLOCK ILLEGAL
FILIO	IBZ	JOB	IO TO BLOCK ZERO
SEGCON	ICN	DEBUG	INCORE COUNT NEGATIVE
ONCMOD	IDC	HALT	IMPOSSIBLE DRUM CONDITION
KISER	IEZ	DEBUG	IOWD EQUALS ZERO
KLSER	IEZ	DEBUG	IOWD EQUALS 0
TAPSER	IFI	STOP	ILLEGAL FUNCTION AT INTERRUPT
NETSER	IFU	DEBUG	INTERRUPT FLAG UNRECOGNIZED
FILIO	IIP	STOP	IO IN PROGRESS ERROR
KISER	IME	JOB	ILL MEM REF FROM EXEC
KLSER	IME	JOB	ILL MEM REF FROM EXEC
DTESER	IPA	STOP	NO POST ADDRESS
VM SER	IPF	DEBUG	IN USE PAGE FREE
VM SER	IPM	DEBUG	ILLEGAL PTR IN MEMTAB
VM SER	IPN	DEBUG	HIPC PAGE NOT FOUND
FILUOO	IUN	DEBUG	INVALID UNIT NUMBER
UOCON	JAC	DEBUG	JOB DATA AREA CLOBBERED
ONCMOD	JDJ	DEBUG	JFFO DIDN'T JUMP
SYSINI	JIT	HALT	JOB IN TRANSIT
CORE1	JJW	STOP	JOB'S JDA IS WRONG
FILIO	JNC	DEBUG	JOB NOT IN CORE
CLOCK1	JNE	STOP	JBTADR NOT EQUAL TO CORTAL
DPXKON	KDS	DEBUG	KONEC2 DIDN'T SKIP
SYSINI	KID	HALT	KONTROLLER IS DOWN
XTCSER	KNF	STOP	KONTROL NOT FREE
D85INT	KR3	STOP	MESSAGE TOO LARGE
TAPSER	KSW	DEBUG	KONTROLLER STATUS WRONG
TAPUOO	LDN	DEBUG	TAPE LABEL DDB NOT FOUND
ERRCON	LN1	STOP	LINE NOT THERE
QUESER	LNF	DEBUG	LOCK NOT FOUND
FILIO	LNP	DEBUG	LAST POINTER NOT A POINTER
SCNSER	LNS	STOP	LINE NOT SET UP
ERRCON	LNT	STOP	LINE NOT THERE
FILUOO	LPU	JOB	LAST POINTER UNIT CHANGE
CP1SER	MAU	DEBUG	MASTER ALREADY UNLOCKED
NETSER	MBE	DEBUG	MONITOR BUFFER EXISTS
METCON	MCM	DEBUG	MCDB IS MISSING
FILFND	MCN	DEBUG	MOUNT COUNT NEGATIVE
DTESER	MDM	STOP	MASTER DTE MISSING
FILIO	MHB	DEBUG	MUST HAVE BUFFER
ONCE	MIW	STOP	MEMORY INTERLEAVING WRONG
VM SER	MIZ	DEBUG	MEMTAB IS ZERO
ERRCON	MMN	HALT	MONITOR MEMORY NXM ERROR
ERRCON	MMP	HALT	MONITOR MEMORY PARITY ERROR
KILOCK	MMR	STOP	MOVING MONITOR PAGE NOT REQ'D
FILIO	MNA	DEBUG	MONITOR BUFFER NOT AVAILABLE
SYSINI	MNM	STOP	MONITOR IN NON-EX MEM
KILOCK	MPN	STOP	MONITOR PAGE NOT FOUND
REFSTR	MSR	HALT	NO SECOND RIB
NETSER	MY1	STOP	BULLSHIT I JUST GAVE SOME BACK
NETSER	MY2	DEBUG	I ALREADY CHECKED THIS IN FEKINT
NETSER	MY4	DEBUG	GARBAGE
NETSER	MY5	DEBUG	GARBAGE
FILUOO	NAP	JOB	NOT ADDRESS POINTER
CLOCK1	NCA	STOP	NO CORE ASSIGNED
ONCMOD	NDC	STOP	NO DF10C CODE
SCNSER	NDJ	DEBUG	NO DDB FOR JOB
CLOCK1	NDP	DEBUG	NOT DDB POINTER

COMPANY CONFIDENTIAL

CLOCK1	NDS	STOP	NULL JOB DID SAVEGET
ONCE	NED	HALT	NO EXEC DDT
FILUOO	NER	DEBUG	NO EXTENDED RIB
UOOCON	NEV	STOP	NO EXEC VIRTUAL MEMORY
FEDSER	NFB	STOP	NO FRONT END DEV BLOCK
DTESER	NFC	STOP	NO FREE CORE
RPXKON	NFD	DEBUG	NO FRONT END DRIVE
VMSER	NFS	DEBUG	NO FIRST SLOT
SYSINI	NFU	DEBUG	NO FIRST UNIT
DTESER	NIS	STOP	DTE IN WRONG STATE
TAPUOO	NIV	STOP	NULL INTERRUPT VECTOR
FILIO	NMB	DEBUG	NEED MONITOR BUFFER
ONCMOD	NMC	HALT	NO MORE CORE
NETSER	NMF	DEBUG	NO MONITOR BUFFER
REFSTR	NMU	DEBUG	NO MORE UNITS
FILUOO	NNF	DEBUG	NMB NOT FOUND
FILUOO	NNR	JOB	NO NEXT RIB
ONCMOD	NNU	DEBUG	NOT NEW UNIT
SCNSER	NOT	DEBUG	NO OPR TTY
SCHED1	NPC	STOP	NO PDB IN CORE
FILIO	NPD	DEBUG	NO POINTER IN DDB
KILOCK	NPF	STOP	NEXT PAGE FREE
KLSER	NPI	HALT	NOT PARITY INSTRUCTION
DATMAN	NPJ	DEBUG	NO PDB FOR JOB
KISER	NPN	STOP	NON-EXISTANT PAGE NOT FREE
KLSER	NPN	STOP	NON-EXISTANT PAGE NOT FREE
KISER	NPP	STOP	NO PI IN PROGRESS
KLSER	NPP	STOP	NO PI IN PROGRESS
ERRCON	NPU	STOP	NULL PDL UNDERFLOW
VMSER	NRF	DEBUG	SWPLST NOT REALLY FRAGMENTED
FILUOO	NRM	JOB	NEXT RIB MISSING
ONCMOD	NRS	DEBUG	NO RIB IN SAT
VMSER	NSE	DEBUG	NO SWPLST ENTRY
FILFND	NSL	JOB	NO SUCH SEARCH LIST
REFSTR	NSS	DEBUG	NO SPACE FOR SAT
FILIO	NSU	DEBUG	NO SUCH UNIT
SCHED1	NTE	STOP	NOT PROCESSOR QUE ERROR
COMNET	NTF	STOP	NT RESOURCE SCREWED UP
FILFND	NUB	JOB	NO UFB BLOCK
FILUOO	NUE	DEBUG	NO UFB ERROR
XTCSER	NUI	DEBUG	NON-EX UNIT INTERRUPT
FILUOO	NUN	DEBUG	NMB USE CNT NEGATIVE
FILUOO	NUP	DEBUG	NO UNIT CHANGE POINTER
VMSER	NUS	DEBUG	NO UNIT FOR SWAPPING
NETSER	NVP	STOP	NOT A VALID PCB
DTESER	NWD	STOP	NO DOORBELL
FILIO	NXU	DEBUG	NON-EXISTANT UNIT
VMSER	O1F	DEBUG	ONLY ONE FRAGMENT
D8SINT	OIP	DEBUG	OUTPUT ON PROGRESS
FILUOO	ONC	DEBUG	ODD NUMBERED CLUSTER
VMSER	P2L	STOP	PAGE TOO LOW
COMCON	PAO	STOP	PAGE ALREADY OUT
DTESER	PCI	STOP	FUNCTION CODE ILLEGAL
IPCSE	PCN	DEBUG	PACKET COUNT NEGATIVE
NETSER	PCW	STOP	PCB COUNT WRONG
FILIO	PDA	DEBUG	POINTERS WITH DIFF. ADDRESSES
VMSER	PEW	DEBUG	PAGTAB ENTRY WRONG
KISER	PEZ	STOP	PAGPTR=0
KLSER	PEZ	STOP	PAGPTR=0
KILOCK	PFA	STOP	PAGE FREE ALREADY

COMPANY CONFIDENTIAL

VM SER	PFC	STOP	PAGE ON FREE CORE LIST
COMCON	PGL	STOP	PAGES GOT LOST
ERRCON	PIE	STOP	PRIORITY INTERRUPT ERROR
VM SER	PIF	DEBUG	PAGE IS FREE
VM SER	PIN	DEBUG	PAGE IN WORKING SET
KISER	PIP	STOP	PI IN PROGRESS
KL SER	PIP	STOP	PI IN PROGRESS
VM SER	PIW	DEBUG	PAGE ISN'T IN WORKING SET
CLOCK 1	PJO	DEBUG	REQUEUE JOB 0
FILIO	PLP	DEBUG	PAST LAST POINTER
KISER	PMU	STOP	PAGTAB IS MESSED UP
KL SER	PMU	STOP	PAGTAB IS MESSED UP
FILIO	PNE	DEBUG	POINTERS NOT EQUAL
FILFND	PNM	DEBUG	PHYSICAL NAME MISMATCH
KILOCK	PNP	STOP	PAGE NOT PRESENT
VM SER	PNW	DEBUG	PAGE NOT IN WORKING SET
CLOCK 1	POP	STOP	PI ON PROGRESS
SEGCON	POR	STOP	PROCESS OUT OF RANGE
FILIO	PQE	DEBUG	POSITION QUEUE EMPTY
KISER	PSF	STOP	PAGE IN SEGMENT FREE
KL SER	PSF	STOP	PAGE IN SEGMENT FREE
KL SER	PTH	HALT	PARITY TRAP HALT
DTE SER	PTL	STOP	PACKET TOO LARGE
KL SER	PTP	HALT	PAGE TABLE PARITY
CORE 1	PTT	DEBUG	PAST TOP OF TABLE
SEGCON	PUF	JOB	PATH UO FAILED
FILUO	PUN	DEBUG	PPB USE CNT NEGATIVE
DTE SER	QEF	STOP	QUEUE ENTRY FULL
SCNSER	QWC	DEBUG	ON WRONG CPU
SCHED 1	RBQ	STOP	REQUEUEING TO BEGINNING OF QUE
SCNSER	RCC	STOP	RANGE CHECKED CHUNK
FSXKON	RDP	DEBUG	RS04 DOESN'T POSITION
SEGCON	RDS	STOP	REMAP DIDN'T SKIP
ERRCON	REH	HALT	RECURSION IN ERROR HANDLER
TAPSER	RFU	STOP	RECOVERY FOULED UP
FILIO	RHN	DEBUG	REREAD HOME BLOCK CNT NEGATIVE
XTC SER	RIE	DEBUG	REMOTE INTERRUPT ERROR
DPXKON	RIF	DEBUG	RP10 ISN'T FANCY
D8SINT	RIP	DEBUG	READ IN PROGRESS
SCHED 1	RJZ	STOP	REQUEUE JOB ZERO
ONCMOD	ROU	HALT	RAN OUT OF UNITS
ONCMOD	RPM	DEBUG	RETRIVAL PTR MISMATCH
VM SER	RPZ	STOP	RETURNING PAGE ZERO
ERRCON	SAC	DEBUG	STRANGE APR CONDITION
CP1SER	SAU	DEBUG	SLAVE ALREADY UNLOCKED
COMMON	SB#	STOP	CPU N S-BUS ERROR
FILUO	SBT	DEBUG	SHOULDN'T BE TRUNCATING
VM SER	SBW	DEBUG	SWPLST BITS WRONG
XTC SER	SCB	DEBUG	SPURIOUS CONI BIT
SEGCON	SCR	DEBUG	SEGMENT COULDN'T BE READ
FILUO	SER	JOB	SETDDO ERROR RETURN
FILUO	SFI	JOB	STR FREE COUNT INCONSISTENT
FILIO	SFU	DEBUG	SWAPPER FOULED UP
VM SER	SIN	DEBUG	SWPCNT IS NEGATIVE
VM SER	SLF	DEBUG	SWPLST FULL
FILUO	SLM	DEBUG	SEARCH LIST MISSING
VM SER	SLZ	DEBUG	SLECNT IS ZERO
SCHED 1	SMU	DEBUG	SWPCNT MESSED UP
SCHED 1	SMU	DEBUG	TRY TO RECOVER FROM GOOF
KILOCK	SNF	STOP	SEGMENT NOT FOUND

COMPANY CONFIDENTIAL

SWPSER	SNI	DEBUG	SWAPPING NOT IN PROGRESS
SCHED1	SOD	STOP	SPACE ON DISK
ERRCON	SOR	STOP	SEGMENT OUT OF RANGE
FILUOO	SPM	JOB	SECOND POINTER MISSING
CP1SER	SPS	HALT	SECOND PROCESSOR STOPPED
ONCMOD	SRE	DEBUG	SAT READ ERROR
SWPSER	SRO	STOP	SPACE RAN OUT
SWPSER	SSD	STOP	SWAP SPACE DISAPPEARED
KILOCK	SSO	STOP	SEGMENT SWAPPED OUT
SWPSER	SWN	DEBUG	SQREQ WENT NEGATIVE
DTESER	T1E	STOP	TO 11 ERROR
XTCSER	TC0	DEBUG	??????????
XTCSER	TC1	STOP	??????????
XTCSER	TC2	DEBUG	??????????
XTCSER	TC3	DEBUG	??????????
XTCSER	TC4	DEBUG	??????????
XTCSER	TC5	DEBUG	??????????
XTCSER	TC6	DEBUG	??????????
XTCSER	TC7	STOP	??????????
FILUOO	TCI	DEBUG	TRUNCATION CHECK INCONSISTENT
FILIO	TMP	DEBUG	TOO MANY POINTERS
REFSTR	TMR	HALT	TOO MANY RETRIEVAL PTRS
ONCMOD	TMU	HALT	TOO MANY UNITS
TSKSER	TND	DEBUG	TASKS NOT DEFINED
DTESER	TNI	STOP	DTE NOT IDLE
DTESER	TQP	STOP	FOUND QUEUE POINT
DTESER	TXE	STOP	TO 10 ERROR
FILIO	UDE	DEBUG	UNIT DOESN'T EXIST
FILUOO	UDM	JOB	UFD DATA MISSING
FILUOO	UFI	STOP	UNIT FREE CNT INCONSISTENT
D8SINT	UID	DEBUG	UNEXPECTED INPUT DONE
ONCMOD	UIF	HALT	UNIT ALREADY IN FILE STR
ERRCON	UIL	STOP	UOO AT INTERRUPT LEVEL
XTCSER	UIP	DEBUG	NOT A UNIQUE INTERRUPT
FILUOO	UNF	DEBUG	UFB NOT FOUND
COMMON	UNJ	DEBUG	ILLEGAL NULL JOB UOO
VMSER	UNL	DEBUG	UPMP NOT LAST
D8SINT	UOD	DEBUG	UNEXPECTED OUTPUT DONE
FILUOO	UPC	JOB	UNIT CHANGE PTR CLOBBERED
KLSEK	UPF	HALT	UNEXPECTED PAGE FAIL
FILIO	UPI	DEBUG	UNIT POINTER ILLEGAL
TAPSER	USW	DEBUG	UNIT STATUS WRONG
VMSER	WAD	DEBUG	WSBTBL AND AABTBL DISCREPANCY
DTESER	WCN	STOP	WRONG CPU NUMBER
KLSEK	WPT	HALT	WRONG PARITY TRAP
SCHED1	XTH	DEBUG	XJOB TOO HIGH
REFSTR	ZBC	DEBUG	ZERO BLOCKS PER CLUSTER

G O O D S T U F F I N D E X - Q T R . 1 F . Y . 7 9

I S S U E # 1 0

- DGKBB V1.10
- CAN'T GET THAT MANUAL
- PART NUMBERS
- EXERCISING THE ELECTRONIC FINGER
- WIRE WRAP/BACKPANEL INFORMATION AND HOW TO USE THE MICROFICHE
- MA20M/MB20M MEMORY PROBLEMS
- KL/KS FEEDBACK FORMS FOR INSTALLATION AND ACCEPTANCE
- STOP CODE LIST

Good Stuff

This document contains sensitive information which shall not be disclosed to personnel outside of Digital Equipment Corporation.

This Newsletter is meant as an information document. It's contents are not necessarily Company Policy. It's a means by which LCG Product Support can distribute some tidbits of information to you.

ISSUE NO.11 — OCTOBER—F.Y. 79

KL10 BASED DECSYSTEM 20 INSTALLATION MANUAL

BY: GRAHAM MORLAND
LCG P.S. QUALITY ASSURANCE

EK - OKL20 - IN - 001

This manual is now available from Communication Services - Northboro. The manual has undergone a major rewrite with the following additional chapters:

- 1) INSTALLATION PLANNING
- 2) SYSTEM INTEGRATION
- 3) DIAGNOSTIC CHECKOUT
- 4) HARDWARE ACCEPTANCE
- 5) REPORTING

All sections are flow-charted and the diagnostic section is complemented with a set of sample diagnostic printouts. Feedback is welcome, either directly to me at MR1-1/S35 or by use of the comments page in the back of the manual.

COMPANY CONFIDENTIAL

RPO6 AND RMO3 DATA SHEET ERRORS

BY: GRAHAM MORLAND
LCG P.S. QUALITY ASSURANCE

The new DECSYSTEM 20 Site Prep Guide contains erroneous information for the RPO6 and RMO3.

The RMO3 steady state current and power are wrong. They should read:

STEADY STATE CURRENT	120V 60 HZ.	=	11.0A
STEADY STATE CURRENT	240V 50 HZ.	=	5.5A
POWER CONSUMPTION	IN KW	=	1.122
POWER CONSUMPTION	IN KVA	=	1.320

The RPO6 steady state current for 50 HZ. systems is wrong. It should read:

3A/PHASE and not 6A.

RPO6 HEAD ALIGNMENT
FOR KS SYSTEMS

BY: DICK BROWN
HARDWARE COURSE DEVELOPMENT

At present, DSRPA will fail running the head alignment program for the RPO6 on the KS10 systems. This problem is being resolved but for the present you will have to connect all cables on the "perch tester" for head alignment. After the CE pack is installed and the MDLI lines substituted with the perch cables and hd cable, deposit and run test 7 then 6, to do the verification. Test 5 is used to do the adjustment. During test 5, by setting the function switch to 6 the hd select can now be incremented.

EDITOR	Art O'Donnell
ASSOC. EDITOR	Nancie Mitchell
EDITORIAL OFFICE	MR1-17S35
GOODSTUFF is published on a monthly-basis.	

REFERENCE: Memorex RPO6 Manual Appendix A-13--A-17.

COMPANY CONFIDENTIAL

TOPS20/MEMORY PROBLEMS

BY: AL SNYDER

ROCKY MOUNTAIN DISTRICT SUPPORT

When a user memory parity error or a recoverable memory parity error occurs on a DECSYSTEM 20 it is possible that syserr may not log the pertinent data to isolate the failure. This occurs when a MPEDEV BUGCHK is called by having said condition. It will be followed immediately by a BUGHLT, usually a FRKPTE; fatal error in fork at PT page. SYSERR has not yet copied the error data when the BUGHALT occurred. You can have the monitor reboot and take a crash dump. Use FILDDT to look at this dump:

```
$ Run FILDDT
FILDDT>Load <system>monitor. EXE
FILDDT>Get <system>dump. CPY.?(Where?is the dump just taken)
```

Then look at locations:

```
MPISEB /
MPISEB + 1/
MPISEB + 2/
MPISEB + 3/
```

Etc.

These locations are the temporary SYSERR Buffer and will hold the data from the memory parity error. You can use this as you would SYSERR to Troubleshoot the problem. The data will be:

1. APR
2. The ERA
3. Logical AND of ADDRESS
4. Logical OR of ADDRESS
5. Logical AND of Data
6. Logical OR of Data
7. SBUS diag's
8. The Bad Data

The location on the Buffer may vary; however, it will always be at MPISEB + ?, and will be easy to decode.

COMPANY CONFIDENTIAL

TEMPORARY FIX FOR PVFU (DAVFU)

BY: JOE KELLEHER/BERT LONGO
LGC PRODUCT SUPPORT/M.E.G.

Data Products has changed the name of their direct access vertical format unit (DAVFU), to programmable vertical format unit (PVFU). This new PVFU can be recognized by the black stamped vendor part number on the module itself #243371-117. They made the change so that it would be compatible with all 2200 series printers--but in the change they introduced a problem! When the "alarms clear" button is pushed, the interface signals "VFU READY" goes not true while the button is in and system software does not know how to handle this.

We have come up with a temporary fix for this problem which should be put into all #243371-117 PVFU's and that is to cut the etch that goes to pin 15 on IC U67 of the PVFU #243371-117.

The same problem exists with PVFU board #251407-049 that Data Products will begin shipping in September, 1978.

See the attached for the chip location and the logical change.

CONT. NEXT 3 PAGES →

NOTE: Remember this is a temporary fix, we expect to receive a formal ECO from Data Products in approximately six-months.

CROSS-REFERENCE: This article is also listed on microfiche under Tech Tip # LP14-TT-3.

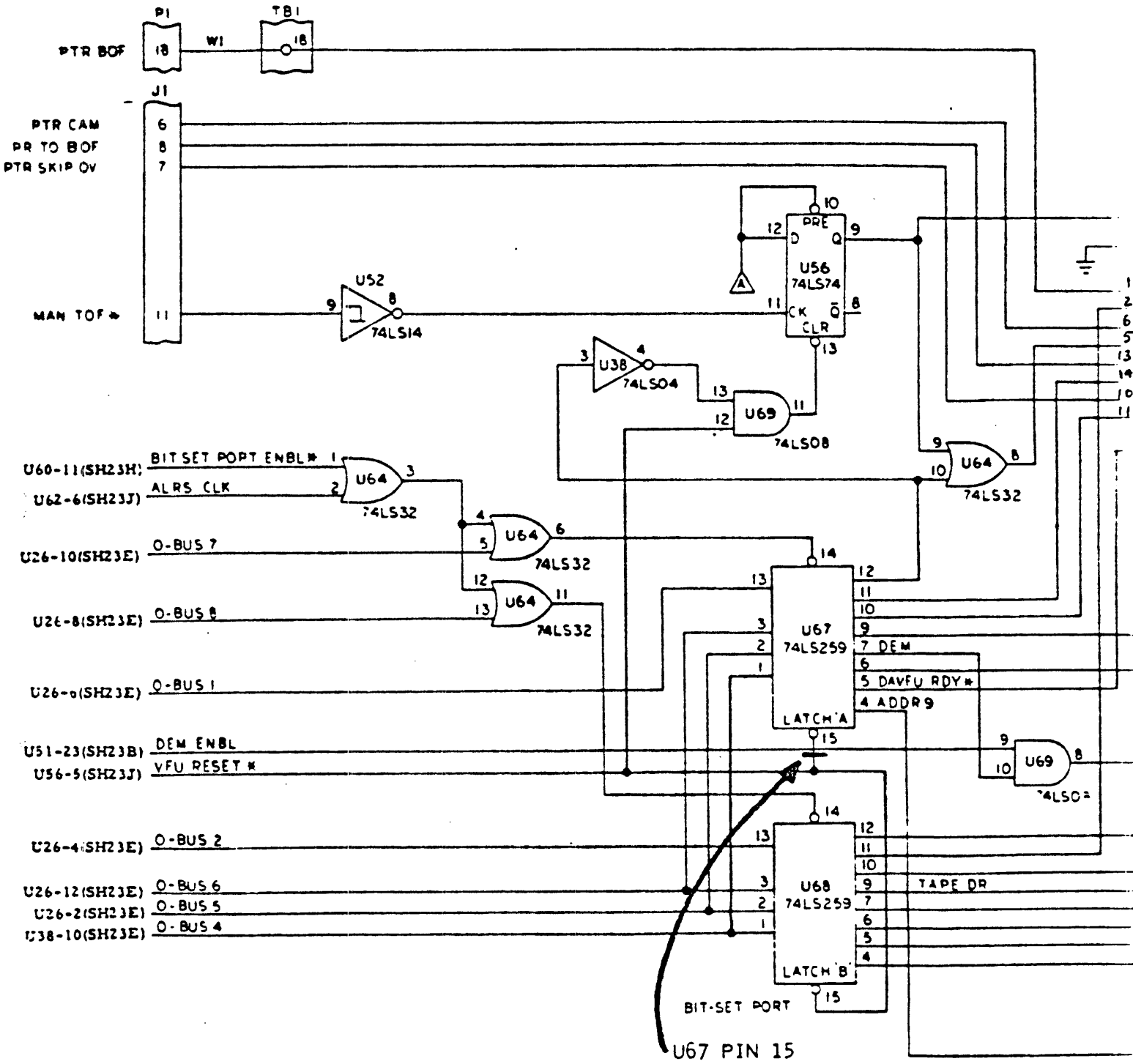

40 39 38 37 36 35 34 33 32 31 30 29 28 27 26 25 24 23 22 21 20 19 18 17 16 15 14 13 12 11 10 9 8 7 6 5 4 3 2 1

© Honeywell Corp 1977 d'0001 no 102401 001

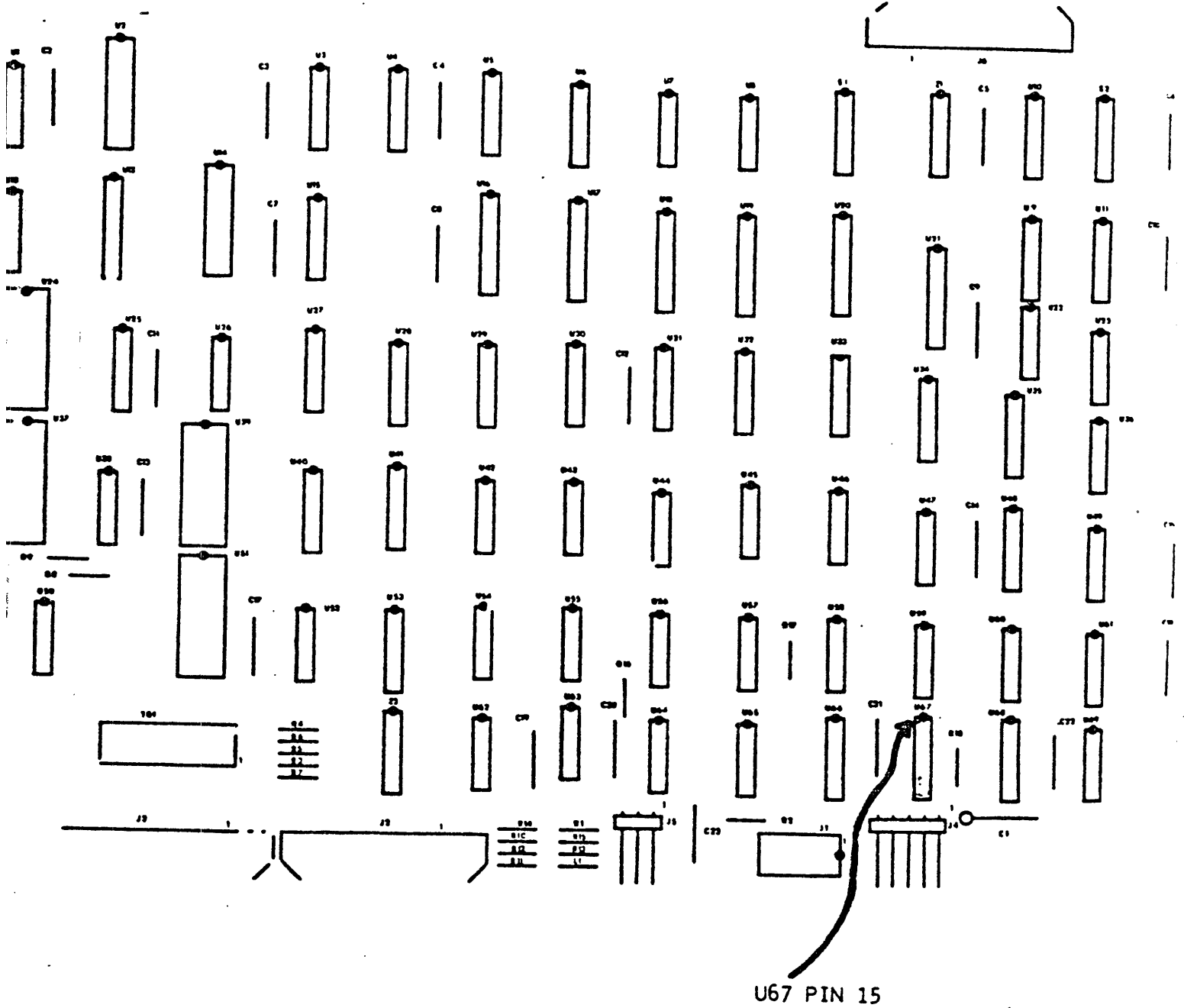

FIGURE 9-78. PROGRAMMABLE VFU ASSEMBLY (OPTION)

COMPANY CONFIDENTIAL

REVISION PACKAGE P2290-47 (49 OF 53)

TABLE 9-78. PROGRAMMABLE VFU CIRCUIT CARD ASSEMBLY (OPTION)

Figure & Index No.	Description	Reference Designator	Part No.	Qty
Fig. 9-78	Circuit Card Assembly		243495-XXX	REF
1.	Printed Wiring Board		243496-001	1
4.	Capacitor, 10uf, 10%, 20V	C1	800041-106	1
5.	Capacitor, .1uf, 20%, 100V	C2 - C22	801311-104	21
6.	Capacitor, 56pf, 5%, 500V	C23	800038-560	1
9.	Socket, Dual-In-Line, 16 Pin	J1	800650-002	3
10.	Connector, Right Angle, 26 POS	J2, J3, J6	800650-002	1
11.	Connector, PCB Mtg, 5 Pin, Right Angle	J4	801034-005	1
12.	Connector, PCB Mtg, 3 Pin, Right Angle	J5	801034-003	1
15.	Inductor, 8.2 UH, 10%	L1	800001-822	1
18.	Connector, 26 POS	P1	801088-026	1
21.	Resistor, 1K, 5%, 1/4W	R1	800030-102	1
22.	Resistor, 560 OHM, 5%, 1/4W	R3, R12, R15	800030-561	3
23.	Resistor, 220 OHM, 5%, 1/4W	R2, R4, R5 R6, R7	800030-221	5
24.	Resistor, 4.7K, 5%, 1/4W	R8, R10, R14 R16, R17, R18	800030-472	6
25.	Resistor, 680 OHM, 5%, 1/4W	R9	800030-681	1
26.	Resistor, 10 OHM, 5%, 1/4W	R11	800030-100	1
27.	Resistor, 330 OHM, 5%, 1/4W	R13	800030-331	1
30.	Switch	S1, S2	801525-001	2
33.	Connector, Flat Cable, 26 POS	TB1	801090-026	1
36.	Integrated Circuit, DpC 74LS173	U1, U12	801545-001	2

*XXX - (-001) 256 x 24 Program Option; (-002) 512 x 24 Program Option

COMPANY CONFIDENTIAL

DN87 UPGRADE

BY: PETER MARIE
M.E.G.

REVISED DECSYSTEM 2020
SITE PREP AND ENVIRONMENTAL
REQUIREMENT

BY: GRAHAM MORLAND
LCG P.S. QUALITY ASSURANCE GROUP

A revised DECSYSTEM 20 Site Prep Manual (EK-DEC20-SP-003) is now available through Communication Services in Northboro.

Included in this manual are the option data sheets for the KS10AA/AB and the RM03.

The 2020 is subject to the site preparation and environmental considerations contained in this manual. Previous pre-release documents pertaining to the 2020 on the above subject matter should be reviewed and revised in light of this new manual.

If the system is going on a Digital Service Contract then particular attention should be paid to table 1-3 on page 1-9 outlining requirements for Maximum System Reliability.

Any questions or queries should be channeled through you local Field Service Organizations.

If you aren't already aware of it, your DN87 can be transformed into a DN87S. This process requires at least one and possibly two or three steps, depending upon the vintage, i.e.: CS/etch and memory type, of your present equipment.

This information is contained in DN87S-U PRE-SALES CHECKLIST (A-SP-DN87S-0-6) which can be obtained from your local sales representative. This document has been provided for pre-sales site inspection purposes. Pre-sales inspection is to provide a reasonable guarantee that DEC and the customer can upgrade the on-site equipment.

The DN87S-U Installation Procedure (A-SP-DN87S-0-5) is designed to aid the Field Engineers in the upgrade of a DN87-B (DN87-B=DN87A/D and DN87-UM) to a DN87S-A. The DN87-U upgrade kit (P/O D-TC-DN87S-0-0) contains the following major components: H324 switch panel, secondary load link components, BM873-YJ ROM loader, DTE-20, KT11-D memory management, ruggedized unibus and supportive hardware. This specification will aid in the integration and checkout of the upgraded DN87.

Remember, if any item on the PRE-SALES CHECKLIST is/are checked NQ, DO NOT proceed with this upgrade. Contact your Account Representative and Branch Office Manager immediately.

THE TEN COMMANDMENTS OF SPARES HANDLING

BY: LEMIS ORTALAN-ALTAN
EDUCATIONAL SERVICES

- 1) THOU SHALT WORK THOUGHTFULLY AND KNOW WHAT THOU DOEST FOR THY APPARENT SLOWNESS WILL BE MORE THAN OFFSET BY FEWER MISTAKES, IN DEED THOU SHALT BE KNOWN FOR THY GREAT WORK OUTPUT AND FEW CALL-BACKS. (THIS IS THE FIRST AND GREATEST COMMANDMENT, IF THOU OBEY THIS COMMANDMENT THOU WILL OBEY ALL THE OTHERS.)
- 2) THOU SHALT TRANSPORT AND STORE SPARES ONLY IN APPROVED CONTAINERS LEST THEY BE DOA WHEN THOU TRY TO USE THEM.
- 3) THOU SHALT NOT BEND COMPONENT LEADS FOR BROKEN SOLDER JOINTS AND COMPONENT SEALS SHALL SURELY CAUSE EITHER IMMEDIATE OR LINGERING DEATH.
- 4) THOU SHALT NOT TRY TO STRAIGHTEN BENT LEADS LEST THEY COME OFF IN THY HAND.
- 5) THOU SHALT NOT DROP OR TOSS MODULES LEST THOU SHALL BE KNOWN AS A CAUSE OF DOA'S.
- 6) THOU SHALT NOT USE FORCE WHEN INSTALLING MODULES OR UNPACKING THEM LEST THOU BE KNOWN FOR THY STRONG ARM AND WEAK MIND.
- 7) THOU SHALT NOT ABUSE FAILED SPARES LEST THOU CAUSE FURTHER DAMAGE AND MAKE ANALYSIS DIFFICULT OR REPAIR IMPOSSIBLE.
- 8) THOU SHALT USE CONDUCTIVE FOAM AND ANTI-STATIC BUBBLE-PACK TO PROTECT FIELD-EFFECT DEVICES FROM STATIC DISCHARGE.
- 9) HONOR THY TECH-TIPS AND KNOW THEM WELL SO THOU CANST CONFIGURE JUMPERS, SET SWITCHES, AND ADJUST POTS CORRECTLY LEST THOU LABEL A SPARE "DEAD-ON-ARRIVAL" WHEN IN TRUTH IT IS THOU THAT IS "DEAD-BETWEEN-THE-EARS."
- 10) WRITE THE SYMPTOMS WHEN THOU REMOVEST THE MODULE LEST THY MEMORY BE POOR WHEN THOU WRITEST THE PAPERWORK. FOR IF THE DATA IS INCOMPLETE OR INACCURATE WE WILL SAY OF THEE "HE LOVES HIS PRESENT QUANTITY OF DOA'S FOR HE TRIES NOT TO REDUCE THEIR NUMBERS."

COMPANY CONFIDENTIAL

CORRECTION ***** CORRECTION ***** CORRECTION

It has come to our attention that the following article which appeared in GOODSTUFF #5 - Page 7 has an error. Please make the following change:

TITLE: RP04/5/6 DIAGNOSTIC FAILURE - FALSE "OPI'S"

The location given for DFRPH-B version 0.2 was incorrect. IT SHOULD HAVE READ:

DFRPH-B - VERSION 0.2 - LOCATION: 47411

GOODSTUFF INDEX

SECOND QTR. - F.Y. 79

ISSUE NO. 11

- KL10 BASED DECSYSTEM 20
INSTALLATION MANUAL
- RP06 AND RM03 DATA SHEET ERRORS
- RP06 HEAD ALIGNMENT FOR KS
SYSTEMS
- TOPS20 MEMORY PROBLEMS
- TEMPORARY FIX FOR PVFU (DAVFU)
- REVISED DECSYSTEM 2020 SITE PREP
AND ENVIRONMENTAL REQUIREMENT
- DN87 UPGRADE
- THE TEN COMMANDMENTS OF SPARES
HANDLING
- CORRECTION - RP04/5/6 DIAGNOSTIC
FAILURE - FALSE "OPI'S"

Good Stuff

This document contains sensitive information which shall not be disclosed to personnel outside of Digital Equipment Corporation.

This Newsletter is meant as an information document. It's contents are not necessarily Company Policy. It's a means by which LCG Product Support can distribute some tidbits of information to you.

ISSUE NO. 12**— NOVEMBER—FY 79**

REWARD

A REWARD will be distributed to Field Engineers who help Corporate Support to identify problems in KL Systems.

A project is underway to make KL's a more reliable product and to give Field Service better methods of repairing them. Your recommendations for solutions to these problems will be greatly valued.

All problem definitions and suggested solutions should be mailed immediately to:

Jeff Gardiner
MR1-1/S35
200 Forest Street
Marlboro, MA 01752

or call...
617-481-9511 X5125/DTN 231-5125

WHAT IS THE REWARD? A more reliable, easier to repair KL.

PLEASE HELP NOW!!!

GOODSTUFF DISTRIBUTION

ADDITIONS: Send a twx or memo stating that you wish to be added to the Goodstuff distribution list - your name, badge, c.c., and location code.

DELETIONS: Return the label from the envelope you receive Goodstuff in stating you wish to be deleted.

CHANGES: Changes can also be made to the distribution list by returning the mailing label with the appropriate change/s written directly on the label.

NOTE: IT IS VERY IMPORTANT THAT YOU DO INFORM US OF ANY CHANGE IN CC, LOCATION, ETC., SO AS YOU CONTINUE TO RECEIVE GOODSTUFF AND ALSO TO KEEP OUR LIST UP-TO-DATE.

Please forward this information to:

Nancie Mitchell - MR1-1/S35
Twx Code: MR11

COMPANY CONFIDENTIAL

REORGANIZATION AND REASSIGNMENT OF DUTIES

BY: BILL FISCHER
LSG FIELD SUPPORT GROUP

I would like to detail the reorganization and reassignment of duties in the Large Systems, Field Support Group, CC 70W, effective November 15, 1978. (Please refer to the following page for organizational chart).

●Lou Nay and John Swan have essentially switched job functions. In looking at Lou's previous duties we see that he was the focal-point for most of the interfacing with the various In-Field Organizations. With his reassignment to the Tools Group Supervisor he will be able to draw upon this experience to guide this group to address the most relevant Field Issues.

In looking at John's previous duties, we see that he has been instrumental in addressing various issues with most of the internal to NORAM/Corporate Groups and will apply this background to resolve the day-to-day field issues in the future.

●We will be relocating the Technical Assistance Center to a location more readily accessible to the members of the Technical Support Group. With the move of the T.A.C. to the new location, will come the reassignment of Betty Hopper to the Technical Support Group.

●The final reassignment involves Elsie Martin, who will move to the Field Quality Group, to apply her skills to enhance the Rework/Special Projects section of this group.

I hope you will join with me in helping each of these individuals, during the transition to their new duties. I view this move as an effort to increase, personal career growth and efficiency/effectiveness of the entire LSG Field Support Group.

SEE NEXT PAGE



Copyright © 1978, Digital Equipment Corporation

FIELD SUPPORT
CC 70W
WILLIAM S. FISCHER

TERRY PERANTONI

FIELD QUALITY
ART O'DONNELL

TECH. SUPPORT
JOHN SWAN

TOOLS
LOU NAY

- GRAHAM MORLAND
- HERMAN MILLET
- NANCIE MITCHELL
- JERRY GANNELLI
- ELSIE MARTIN

TAC

BETTY HOPPER

- LARRY BURKE
- PETE CRIBB
- CARY DEVAN
- MIKE FLYNN
- DINO GENOVA
- JOE KELLEHER
- ED MALONE
- BOB MALONEY
- B. MCKINSTRY
- WALT PETROSKI
- NIGEL WEBB
- DON WERTH

- JACK WALDEN
- TEMP. JEFF GARDINER
- TBH

COMPANY CONFIDENTIAL

PH2DNA UPDATE

BY: TED WOJCIK
M.E.G.

As reported in July 78 Goodstuff a PH2DNA BUGINF Syserr Report is a good source of information when you're trying to figure out what's going on. For release 3A of TOPS20 the usefulness has been extended somewhat and now some further information is available.

First, the contents of AC 1 are the results of CONI RH of the offending RH20. Second, an "additional data item" which is printed at the bottom of the report now contains the channel number.

The additional items should aid greatly in finding and fixing the bad RH20.

EDITORArt O'Donnell
ASSOC. EDITOR...Nancie Mitchell
EDITORIAL OFFICEMR1-1/S35

GOODSTUFF is published on a
monthly-basis.

UNEXPLAINED DEC-20
FRONT END RELOADS

BY: RICK WATSON
CHICAGO DISTRICT

If you have been experiencing front end reloads for no apparent reason on your DEC-20 System, this information may be helpful. If the interrupt enable bit in one of the DH11's resets or if the DH11 gets a Unibus timeout during an NPR transfer, RSX20-F version 12 gets caught in a very tight program loop. Since it cannot update the keep-alive counter while in this loop, the 10 will reload the 11 and SYSERR will report a front end reload with no errors detected.

To find out if this is what's bugging you, turn off the ROM Reload enable switch for DTE #0 and wait for the front end to loop. When it does, halt it and read the address lights. If 30634, 30642, 30644, 30650, or 30656 is what you see, then a DH11 is probably the culprit. The address of the bad DH will be in R4. If you want the find out which of the two errors occurred, reload the system and use the PARSER to deposit 0 into 11 location 30466. This will halt the 11 upon detection of the error and you can examine the system control register of the DH in question. If bit 6 is off, interrupt enable was reset. If bit 10 is on, a NXM was detected.

COMPANY CONFIDENTIAL

RSX20F STOP CODES

BY: TED WOJCIK M.E.G.

This is a list of all known STOP CODES in RSX20F. It has been compiled from the source code of RSX20F and is a complete list. In the past there has been some confusion over RSX stopcodes and TASK stopcodes. This list is only RSX20F stopcodes. In addition to appearing here it will be included in the next update of the SYSERR manual. In the future we hope to publish the task stopcodes as well.

Crash Code	Module	Meaning
BF1	QPRDTE	BUFFER FAILURE 1 free space allocation failed for DTE-20 protocol header
B02	QPRDTE	BUFFFFER OVERFLOW 2 free space allocation failed for data transfer request in a TO-11 request
B03	SCOMM	BUFFER OVERFLOW 3 free space allocation failed on a TO-10 queue request
CBR	PF	CROBAR ERROR DTE-20 power has not returned after a power-fail restart
DTB	QPRDTE	TO-11 DTE-20 TRANSFER FAILURE The TO-11 address after a TO-11 transfer is not what was expected
DTD	LC	DTE-20 IS DEAD The 11 got a unibus timeout on the DTE with no powerfail
DTF	QPRDTE	TO-10 DTE-20 TRANSFER FAILURE The TO-10 address in the DTE-20 after a TO-10 transfer was not what was expected
EPE	QPRDTE	E-BUS PARITY ERROR A DTE-20 command has resulted in an KL10 E-Bus parity error
ETE	QPRDTE	TO-11 TRANSFER ERROR After a TO-11 transfer, TO11ER (TO-11 Error) is on in the DTE status register.

COMPANY CONFIDENTIAL

RSX20F STOP CODES

FTA	LC	FILES TASK ABORTED A task occupying F11TPD has aborted, TKTN cannot be requested
IAS	SCH	UNKNOWN SIGNIFICANT EVENT An unused bit in .SERFG has has been set
ILF	QPRDTE	ILLEGAL FUNCTION--PROTOCOL A protocol function within the legal range but currently unimplemented has been received.
ILQ	QPRDTE	ILLEGAL QUEUE COUNT The protocol queue was not expected (i.e. was not incre- mented by 1)
LRF	SCH	LOAD REQUEST FAILED An attempt to load a non- resident monitor routine into the F11TPD partition failed
MPE	LC	MEMORY PARITY ERROR An eleven parity error has occured
NPF	DMDTE	NON-PRIVILEGED FRONT END A front end connected to a DTE-20 tried to enter boot protocol
PT1	QPRDTE	PROTOCOL BROKEN An illegal protocol device number was specified in a TO-11 request
PT2	QPRDTE	PROTOCOL ERROR 2 An illegal protocol function was specified in a TO-11 request
PT3	QPRDTE	PROTOCOL ERROR 3 The indirect in progress bit was set in the protocol; however, no TO-11 request was in progress.
PT4	QPRDTE	PROTOCOL ERROR 4 Queue size has exceeded 100(10)

COMPANY CONFIDENTIAL

RSX20F STOP CODES

RES	LC	RESERVED INSTRUCTION TRAP This is the PDP-11 Trap to location 10. An attempt was made to execute an illegal or reserved instruction
TO4	LC	TRAP AT LOCATION 4 Odd address, timeout, stack violation, RPO4/06 error
TBT	LC	T-Bit TRAP A BPT instruction was executed or the T-Bit was set by an RTI/RTT
TET	QPRDTE	TO-10 TRANSFER ERROR Either TO-10ER or MPE11 is up in the DTE-20 status register
UIE	QPRDTE	UNIMPLEMENTED PROTOCOL FUNCTION. Either bit 0 or bit 2 was set in the protocol status word
UNT	LC	UNRECOGNIZED TRAP ERROR A trap occurred to an unused vector

DECSYSTEM 20 CABLE INFORMATION SHEET

BY: GRAHAM MORLAND
LCG P.S. QUALITY ASSURANCE

Ever get tired of compiling cable lists for new system orders? On the following pages are two sheets whereby you can specify your exact requirements with the minimum of effort. This information is very important to Manufacturing. They want to test your system and cables.

Let your salesmen know and get them to submit this information plus a floor plan with the MOF (Master Order Form). You in return will receive your system tested with your cables, hence minimizing the risk of bad or incorrect length cables.

→ CONT. NEXT TWO PAGES

COMPANY CONFIDENTIAL

DECSYSTEM 20

CABLE INFORMATION SHEET

CUSTOMER NAME: _____ P.O. #: _____

DEC #: _____

INSTALLING REP.: _____ TELE. #: _____ EXT.: _____

BRANCH REP.: _____ TELE. #: _____ EXT.: _____

BRANCH SUPERVISOR: _____ TELE. #: _____ EXT.: _____

SALES REP.: _____ TELE. #: _____ EXT.: _____

FROM	TO	CABLE	# REQUIRED	LENGTH
RP04/RP06 DISK DRIVES	RH11	BC06S		15'
				*25'
				40'
NOTE: MULTIPLE DRIVES SHOULD BE ADJACENT TO ONE ANOTHER.	RH20	BC06S		15'
				*25'
				40'
	RP04/RP06	BC06S		*2'/2.5'
				10'
	CPU	GROUND		15'
				*25'
				40'
	RP04/RP06	GROUND		*2'/2.5'
				10'
	RP04/RP06	70-6600-01 (PWR JUMPER)		2'/2.5'
	RP04/RP06	70-9491-01 (SEQ. CABLE)		*2'/2.5'
				15'
				25'
			40'	
N/A	RTO	N/A	N/A	N/A

* = DENOTES STANDARD CONFIGURATION CABLES.

COMPANY CONFIDENTIAL

DECSYSTEM-20

CABLE INFORMATION SHEET

CUSTOMER NAME: _____

FROM	TO	CABLE	# REQUIRED	LENGTH
TU45 TAPE DRIVE NOTE: 1 TMØ2 WILL SUPPORT 4 TU45'S; THEREFORE CABLE RESTRICTIONS DICTATES THAT THE ASSOCIATED TU45'S MUST BE BOLTED TOGETHER.	RH2Ø	BCØ6S		15'
				*25'
				40'
	TU45	3/BCØ6R		5'
	CPU	GROUND		15'
				*25'
				40'
	TU45	RTO		5'
	CPU	RTO		25'
	CARD READER	CD2Ø	7Ø-Ø8764	
LINE PRINTER	LP2Ø	7Ø-11426		*25'
				50'
				75'
				100'
LINE PRINTER	CPU	GROUND		*25'
				50'
				75'
				100'
DC2Ø	LOCAL LINE	BCØ3M		*100'
DC2Ø	REMOTE LINE	BCØ5D		*25'
DL11-E	KLINIK	BCØ5C		*25'
N/A		MASS BUS TERMINATOR		N/A

* = DENOTES STANDARD CONFIGURATION CABLES

COMPANY CONFIDENTIAL

ESTABLISHING KLINIK CONNECTIONS FOR REMOTE DIAGNOSIS

BY: RICH PETTI
D.D.C.

We in the D.D.C. are experiencing a particularly annoying problem in establishing KLINIK connections for calls received from the Field. Problems range from bad telephone lines to bad DL11E's. The KLAD pack has been the main instrument in establishing that connection using it to boot KLDCP. We could use your help in remedying the majority of problems and in turn you'd be helping yourselves and your customers.

If the latest version (at least V16) of KLDCP was on a floppy (for 20XX's) or a dectape (for 10XX's) we could establish connections quickly by simply having customers boot in KLDCP and type "KLINIK", no other dialogue or switches necessary. This will also make it easier and take less time to identify KLINIK link problems. It also provides us with all we need to take a hardware crash dump and saves time in getting down systems up. If it is necessary to run diagnostics, the KLAD pack could then be mounted and again without any dialogue, switch settings, or other customer actions the pack could be accessed. As an alternative method of loading KLDCP and establishing a connection the KLAD pack could then be used.

PLEASE HELP IN THE FOLLOWING WAYS:

1. Have the latest version (at least V16) of KLDCP on floppy or dectape.
2. Leave copies of instructions in establishing KLINIK links via floppy, dectape and the KLAD pack with your customer.
3. Check the KLINIK link locally to verify the procedure and the hardware when the system is not down.
4. If you cannot check the KLINIK line, we'd be glad to check it for you and do a SYSERR analysis or run diagnostics for free!

These few items will help us all resolve most of these problems quickly and easily.

COMPANY CONFIDENTIAL

RPO4 AND RPO6 OFF-LINES

BY: JEFF GARDINER
NER PRODUCT SUPPORT

After extensive testing in Marlboro with the cooperation of Don Dossa of H.O.S.S., Tony Wachs of Software Engineering and Len Kreidermacher's Engineering Group I can say with confidence that the hardware and software should give proper information when a hardware error occurs.

The off-line condition is a catch-all for any error the monitor can not successfully recover from.

The monitor uses the drive status register information (MOL,DRY,VV) to decide if this drive is o.k. This is called "good status".

Several things must be considered when a off-line occurs;

1. The off-line is caused by a hardware error condition.
2. The monitor should be 6.03 or later with 6.03A RPXKON.
3. The disk and controller must be up to latest ECO level. (refer to the microfiche LC Rev - INDEP unit).
4. The off-line condition should be recoverable if the operator cycles the drive down and then up again. If the off-line does not recover then diagnostics should easily find the hardware problem.

If any of the above considerations do not exist then the off-line will be misleading to both hardware and software engineers alike.

When the monitor is performing a data transfer only--errors which are considered recoverable and appropriate are checked. (DCK, HCRC, HCE, ECH, FER).

When the drive is doing a positioning operation--only errors that are recoverable under that condition are checked. (SKI, UNS).

Any other type of error that occurs and cannot be cleared by a drive clear will cause an off-line, similarly, if an SKI or unsafe error should come up during a data transfer or a data error should occur during a positioning the drive will be reported as off-line. It is important to consider that these circumstances should not occur unless there is a severe hardware problem.

Unsafe conditions will only be tested at positioning operations or when the monitor is trying to connect to the drive and are, most likely, fatal to the hardware anyway.

CONT. NEXT TWO PAGES
→

COMPANY CONFIDENTIAL

The monitor uses the status register and error register 1 to decide whether or not there is a drive problem by looking at the composite error bit. When this bit is set the monitor goes into error recovery and issues 2 drive clears and then attempts to retry the operation. During the next connect to the drive the error is checked again. If the error is still there the monitor will report that the drive is "off-line".

It is possible that the error will not be reported to syserr because DAEMON was swapped out on the drive that went off-line or error.sys was on the drive and DAEMON could not open the error file on this unit.

This would cause an off-line with no corresponding entry in syserr. When this occurs it is possible to examine the drive registers using FILDDT.

The current drive using the controller has its registers stored in the controller data block offset by KONEBK. If the serial number (KONEBK+10) matches the drive that went off-line then the registers are valid for that drive error.

The monitor stores the drive registers at the detection of the error. They will be found in the unit data block for that unit, offset by UNIEBK. The four registers that are of primary importance are:

UNIEBK+1	;THE STATUS REG
UNIEBK+2	;ERROR REG 1
UNIEBK+14	;ERROR REG 2
UNIEBK+15	;ERROR REG 3

It is also wise to check UNIEBK+10 to be sure that the drive serial number matches the drive that went off-line.

These locations are in half-word format with the first entry in the left half and the entry after retry in the right half.

If hardware monitoring is preferable over software analysis then the DDU should be attached to the RPO4 (perch tester for RPO6). It will latch the drive error in the tester and will not clear with a drive clear. This will allow software recovery of the error without losing the error indication of the drive.

Unfortunately, this will not detect errors that are developed in the DCL. A logic analyzer would be the best method of trapping the total error condition.

COMPANY CONFIDENTIAL

CONCLUSIONS:

1. Off-lines are caused by hardware failures!
2. They should be recoverable! Either via software or cycling the drive.
3. They may not be recorded in syserr!
4. Only a few of the error conditions are specifically checked!
5. "Off-line" can describe many error conditions!
6. If the hardware error is unrecoverable then the drive is "off-line".
7. We will continue to see "off-lines" in the Field forever!
8. The coding to check and report each of the 38 possible error conditions could cause extreme monitor overhead if executed during every interrupt.

LP14 PRINT PROCESSOR BOARD

BY: BERT LONGO
M.E.G.

Please interrogate your LP14 printers and the inventory on hand for old print processor board, DEC part number: 29-22865 corresponding to DpC part number: 243485-XXX stamped in ink on the board.

KMC11 SWITCHES

BY: ROBERT NOBREGA
IHFS LCG

I recently discovered an error in the DN21 prints. On sheet 8 of 10 in the front of the DN21 Field Maintenance Print Set there is a table which shows how to configure the switch packs on the KMC11. The chart for KMC11 #2 shows switch pack E65 switch 4 in the "off" position. This switch should be in the "on" position. If the switches are set as in the chart the vector will be set to 600 instead of 700 as it should be.

In the event that you have one of these boards, please contact via twx, memo or phone:

Bert Longo - MR1-1/S35 -X231-6322
or
George Morrison - MR1-1/S35
X231-6323

Your input is highly appreciated.

COMPANY CONFIDENTIAL

GOODSTUFF INDEX - 2ND QTR.
FISCAL YEAR 79

ISSUE NO. 12

- REWARD
- GOODSTUFF DISTRIBUTION
- LSG FIELD SUPPORT REORGANIZATION
- PH2DNA UPDATE
- UNEXPLAINED DEC-20 FRONT END RELOADS
- RSX20F STOP CODES
- DECSYSTEM 20 CABLE INFORMATION SHEET
- ESTABLISHING KLINIK CONNECTIONS FOR REMOTE DIAGNOSIS
- RPO4 AND RPO6 OFF-LINES
- KMC11 SWITCHES
- LP14 PRINT PROCESSOR BOARD
- LSG FIELD SUPPORT REORGANIZATION

GOOD STUFF

This document contains sensitive information which shall not be disclosed to personnel outside of Digital Equipment Corporation.

This Newsletter is meant as an information document. It's contents are not necessarily Company Policy. It's a means by which LCG Product Support can distribute some tidbits of information to you.

ISSUE NO. 13 — DECEMBER — FY 78

HAVE YOU CHECKED YOUR CAREER PATH LATELY?

BY: GREG BARKER
LCG FIELD SERVICE TRAINING

If you have been to a training course in Marlboro within the last two-years, you are aware of the efforts going on there to improve Course Content and Quality Control. All courses are now based on specific written objectives. These objectives provide a focal-point for both the student and instructor. They are truly a contract between the two and provide the basis for determining the quality of our training efforts. Two questions may be asked, "Has there been an improvement in the quality of training over the last two years?" "The answer is YES!". Then, "Is there room for more improvement?" "The answer is "Absolutely!".

One important way to improve the quality of LCG Field Service Training is to include several good LCG Field Service Engineers on our instructor staff. Educational Services is a branch of your career path you may not have thought serious about. Now is the time to consider it. You may need this kind of career broadening assignment and LCG Training needs you.

Now, ask yourself two more questions, "Have you considered the personnel growth afforded you by an assignment in Educational Services?" Then, "Have you considered your value to the Field Service Organization by being in a position to share your LCG experience with Digital new hires?"

No doubt you would like to help improve the quality of our training program. No doubt you would like to strengthen the Field Organization? So now is the time to consider an assignment in LCG Field Service Training.

If you want to talk about the possibility of a tour-of-duty as an instructor, either with a planned return to the Field or, as a permanent career change, talk it over with you Supervisor. After he screams, "NO!" Tell him how you are going to improve the quality of training. Then, when he smiles and says "YES!" talk to your personnel representative and give me a call.

DEPOSIT/EXAMINE FAILURES

BY: MIKE FLYNN
LCG PRODUCT SUPPORT

We have discovered that a parity error detected by the AR during an examine by the DTE20, will cause the DTE20 to hang. This will result in a deposit/examine failure. This situation may occur during BYTE transfers also.

It is important to note that the logic used for examines is basically the same logic used to perform diagnostic functions in the KL10. The information received from diagnostic functions performed after deposit/examine failures will be "INCORRECT" until a reset of the DTE20 is performed. (Deposit eleven 174432/100 = reset DTE20 only).

I personally recommend that a reset of the DTE20 be performed before "ANY" of the KL10 diagnostic functions are used.

Cross Reference: KL10-TT-61.

EDITORArt O'Donnell
ASSOC. EDITOR...Nancie Mitchell
EDITORIAL OFFICEMR1-1/S35

GOODSTUFF is published on a monthly-basis.

It is not normal procedure to publish articles in Goodstuff regarding the nature of the article on page 1, but following review by senior Field Service Management, the inclusion of this article was deemed appropriate due to the severe shortage of field experienced instructors.

DGKBB KL10 MEMORY SYSTEM

DIAGNOSTIC

BY: HERMAN MILLET/JERRY GANNELLI
LCG PS QUALITY ASSURANCE

There is a problem with DGKBB that becomes evident when an M8525 at Module Revision Level "F" OR "H", is installed in the system. With this rev. M8525 board, "DGKBB.All version 1.10" has problems configuring external memory. You can prevent this failure by installing the following patch to DGKBB:

CHANGE LOC	FROM	TO
43212	132	107

A new version of this diagnostic, "DGKBB.A11 version 0.11", will be provided with the next klad update.

SOFT ERROR BAD SPOTS

BY: RUSS MYERS/RAIMO NAHRI
KANATA

A convenient method to map out soft errors with 6.03 monitor and DDRPI, is to run one pass RONLY, enable syserror reporting but disable monitor retries. This fakes monitor to believe that all DCK errors are non-recoverable, and they will be automatically mapped as bad spots.

This may be advantageous to prevent monitor recovering the same soft spot every time it is accessed.

COMPANY CONFIDENTIAL

LET'S GET OBJECTIVE

BY: JOHN SWAN
LCG PRODUCT SUPPORT - TOOLS

Students who are coming to Marlboro for LCG training may be interested in what they will be doing in the courses. The objectives of all LCG courses are listed on microfiche under a purple header titled--TRAINING, which can be found in the LCG microfiche library.

Studying the objectives and reviewing the prerequisite training which is listed in the course catalog may help both student and manager/supervisor to determine which training courses best meet their requirements.

LP07 PRINT QUALITY WITH
MULTIPART FORMS

BY: BERT LONGO
M.E.G.

Are you dissatisfied with LP07 print quality when using multipart stock, especially in check application?

If you are, have you checked and set correctly the appropriate adjustments described in "Model 2550 Line Printer, Charaband Operator's Guide"?

If still not satisfied, better print quality can be obtained by reducing the print rate; that is, position the "Print Rate" switch to "low" position.

ADDITION TO "HOW TO GET DATA ON
INTERMITTENT EBUS PARITY ERRORS"

BY: DAVE ROCKWELL/DICK WHITE
IN-HOUSE FIELD SERVICE

Bill Hilliard outlined an excellent technique in a tech tip which appeared in GOODSTUFF #8 which allows one to recover data on an EBUS parity error.

In the first section where he describes how to prevent the software from "doing you in" the location to change was for RSX20F Ver. 10-12 and was location 44110.

In the course of shooting a similar problem in-house it was learned that the magic location for RSX20F Ver. YB12-34 is 43754. This version has appeared on systems running TOPS20 Release 3A.

PM CHECK - 728 POWER SUPPLY

BY: KEN BOUCHARD
WESTERN REGION SUPPORT

On older equipment (RP10,DF10, etc.) the 728 power supply is used quite frequently. As this power supply ages, ripple becomes worse. Make it a part of your PM to check this because it can cause intermittent failures. If you have a 728 that's out of SPEC*--try replacing the DM-1 bridge and then the filter caps. If this doesn't help, replace the whole supply and send the old one back.

*Consult individual device manuals for SPECS.

COMPANY CONFIDENTIAL

HOW TO GET A REAL SNAP-SHOT OF A KL10 SYSTEM!

BY: MIKE FLYNN
LCG PRODUCT SUPPORT

(VERSION II)

In the old days, when a computer system stopped doing its thing, there were lights to look at and buttons to push for the maintenance guy to try and see how bad the situation really was.

Today...no lights and no buttons (KL10)!

The following steps will allow you to examine a KL10-based system's processor, memory and sub-components in a relatively undisturbed state with these considerations:

1. Remember the device that you loaded KLDCP from, because that device and it's controller may be changed.
2. Pushing the load button on the KL, causes a unibus init. (Reset) and any device on the unibus may have been reset.

These steps should be used to gather accurate data on systems with intermittent problems.

ALL KL10'S

<u>TYPE TO KLDCP</u>	<u>WHERE</u>	<u>WHAT</u>
EE 174434	P. 1-29 D.T.E.M.	;DTE STATUS
EE 174430	P. 1-30	;DTE DIAG 1.
DE 174432/100		;RESET DTE20 ONLY.
FX0		;TURN OFF CLOCK.
ALL		;LOOK AT ALL REGISTERS.
FR100,177	P. 61-84	;GET ALL FUNCTION READS.
ECO		;RESET MACHINE AND MICRO-CODE ADDRESS TO "0".
FX1		;TURN ON CLOCK.
FX0		;TURN OFF CLOCK.
EC		;LOOK AT MICRO-CODE ADDRESS. IS THIS THE HALT-LOOP FOR YOUR MICRO-CODE? ;NO, RUN DIAGNOSTICS. ;YES, CONTINUE.

COMPANY CONFIDENTIAL

<u>TYPE TO KLDGP</u>	<u>WHERE</u>	<u>WHAT</u>
FX1		;TURN ON CLOCK, TO ALLOW INTERRUPTS WITH EXAMINES.
EM16		;CAN YOU EXAMINE? ;IF NO, RUN DIAGNOSTICS. ;IF YES, CONTINUE.
EX 700000 17, EM17	P. 34	;APRID., OPTIONS, VERSIONS, SERIALS.
EX 701040 17, EM17	P. 37	;DATA PAG., AC BLKS., SECTION, UBR.
EX 701240 17, EM17	P. 37	;CONI PAG., ENABLES, EBR.
EX 700400 17, EM17	P. 35	;RDERA., ERROR ADDRESS REGISTER.
EX 720240 17, EM17	D.T.E.M. P. 1-26	;CONI DTE #0., DTE STATUS.
DM 16/100000,0		;SBUS DIAG. FOR DMA20.
EX 700500 16, EM17		;ERROR ADDRESS REGISTER.
EM ?500,?502	P. 22/23	; ? = UBR. ;?500 = PAGE FAIL WORD. ;?501 = PAGE FAIL PC+FLAGS. ;?502 = PAGE FAIL PC. ;UBR = 0 (500) ;UBR = 1 (1500) ;UBR = 2 (2500)
AC BLK 7	P. 32&33	;MICRO-CODE AC BLOCK.
EM0,2	P. 32&33	;ACO = AR DATA FOR PAGE FAIL. ;AC1 = ARX DATA FOR PAGE FAIL. ;AC2 = I/O PGF WORD.
AC BLK 0		;SET AC BLOCK TO 0.

Function read 110 with the page fail word (?500) plus the error address register (ERA), the DMA20 address register, and the page fail information should give you a good starting point.

COMPANY CONFIDENTIAL

FOR YOUR INFORMATION:

- D.T.E.M. = DTE MANUAL.
 - PAGE NUMBERS WITH NO LETTERS ARE IN THE KL MAINTENANCE HANDBOOK.
 - PAGE TABLE INFORMATION IS LOCATED ON PAGES:
22, 23, 24, 25, 26, 27, 32, 33, and 40.
 - PAGES: 22 & 23 - GIVES PAGE TABLE BY LOCATION.
 - PAGES: 24 & 25 - GIVES BREAKDOWN OF PAGE TABLE ENTREES FOR KL PAGING.
 - PAGES: 26 & 27 - GIVES BREAKDOWN OF CHANNEL EPT AREA ENTREES.
 - PAGE: 32 - GIVES BREAKDOWN OF "PC WORD".
 - PAGE: 33 - GIVES BREAKDOWN OF PAGE FAIL WORD.
 - PAGE: 40 - GIVES BREAKDOWN OF CHANNEL COMMAND WORDS.
-

IME STOPCODES WITH SCHEDULER LIR

BY: WILLIAM LYNCH

MR1-2/S43

A recent SPR pointed out that IME stopcodes were occurring with the use of one of the "SCHED. UO" functions introduced by the Scheduler LIR. Specifically, function 24 which reads or writes the scheduler fairness factor for CPUO was trying to write to the Monitor high segment. To avoid this problem, MCO 8090 should be installed:

In COMMON at QMXTAB + 11 remove

\$HIGH

This will move the referenced location to the low segment.

Any questions involving this or any other new SCHED.function can be resolved by referring to SCHED - Program Logic Manual for Scheduler and Swapper in Software Notebook 11 (this was part of Update 67).

NOTE: This article originally appeared in The Large Buffer - Vol.429, 12 Oct 78.

COMPANY CONFIDENTIAL

STOCKROOM 126 RETURNS

NOTE: This article originally appeared in COD NOTES...NOVEMBER

The following suggestion will speed up the credit processing of returns shipments to SR126 in Woburn:

All U.S. Branches should submit one R/A per carton because, presently, delays are incurred when multiple cartons are returned under one R/A. The cartons frequently become separated in transit and the credit process for that R/A is delayed until all of the cartons arrive in SR126. If one R/A per carton is submitted, credit would be delayed only on those cartons not yet received in Woburn.

All cartons should be properly identified on the outside with R/A number, and a xerox copy of the R/A form should be attached to the outside box. This set of procedures is a suggestion but highly recommended to speed up credit processing. Approval as a permanent policy and procedure is being pursued for NORAM and Foreign cost centers also.

●ORDER RECEIPT QUESTIONNAIRE

Most orders being packaged in Stockroom 17 will have a questionnaire enclosed. For those who do not, a copy of the questionnaire appears on the following page.

This questionnaire should be filled out by the receiving Branch with either positive or negative comments. A problem that may have occurred should be noted on this sheet to alert SR17 personnel of the situation to prevent problems in future shipments. If no problems occur, fill it out also. In both cases, mail the form to:

DIGITAL EQUIPMENT CORPORATION
36 Cabot Road
Woburn, Massachusetts 01801
Attention: Marvin Grote - WO/S72

WE NEED TO HEAR FROM YOU!!!!

Current returns of questionnaires to SR17 are approximately 20%. We need your information to improve our operations. Please submit these questionnaires to the above address as much as possible.

COMPANY CONFIDENTIAL

ORDER RECEIPT QUESTIONNAIRE

The Field Service Logistics Packing Department requests that you fill out and send this questionnaire when:

1. A problem arises to our department.
2. A favorable mention is needed.

If a part arrives defective, please fill out why it arrived in this condition. By doing this, we can resolve these problems and assure that it will not happen again.

	YES	NO
1. Improper use of bubble wrap.		
2. Not using enough bubble as a cushion.		
3. Damage by heavier part.		
4. Flo-pack (peanuts) lodged in part.		
5. Instapak chemical foam on the part.		
6. List any additional problems on the reverse side of this questionnaire.		

Overall rating of material identification and packaging (on progressive scale from 0 to 10). _____

Packaged by: _____

General Information:

1. Date: _____
2. Cost Center: _____
3. Order Type: _____
4. SBA #: _____
5. Date Received: _____

Name of person completing this questionnaire:

EXT.:

COMPANY CONFIDENTIAL

KL10 MODEL B SITES - MICROCODE VERSION 212

BY: DALE COOK

LARGE COMPUTER DIAGNOSTICS

All KL sites covered by a current Software Maintenance Service have recently received media containing the latest release of the KL10 functional microcode, Version 212. This release was made to correct an infrequent, but serious problem which occurred when the basic KL hardware was changed to Model B. The symptom of this problem is system crashes with fast memory parity errors, the frequency of which is increased with Version 12 of COBOL. This problem affects both TOPS-20 and TOPS-20 sites, but does not affect Model A sites.

Part numbers relating to the microcode update are as follows:

DEC-10-OTMMA-D-UB
AL-D129B-SB

RSX20F DEctape
KLINIK RSX20F DEctape

The master DEctapes were submitted to the SDC in swapped canisters indicating swapped part numbers. The tapes were also distributed as such. Please run directories of each tape to confirm the contents, and then return the tapes to the correct canisters identified above. The directories contained in the canisters are also mislabeled indicating swapped part numbers.

It is essential that the appropriate tape be returned to its correctly labeled canister to insure that future revisions to these DEctapes will replace the correct tape at your site.

If you have any questions concerning this problem, please contact your local Software Specialist.

NOTE: The above article originally appeared in The Large Buffer Vol. 430 - 19 Oct 78.

DFRHB FAILURES

BY: STU KENNEDY
DDC 10/20

If test 153 of DFRHB fails on all RH20's on the system and both channel diagnostics run (DGKBD and DGKBE) then it is very likely that you have a bad C Bus translator (8516). This test in DFRHB is the first time that they moved any data over the channel bus itself.

MORE DFTUE FAILURES

BY: KEITH PATTERSON
DDC 10/20

DFTUE Ver. 0.4 may fail test 14 of "Basic 1", this could be caused by Rev. D M8557. Basic 2, reliability, channel diagnostics, and DFSXA run without error. Back one Rev. to Rev. C fixes diagnostic.

COMPANY CONFIDENTIAL

BUILDING MONITORS FOR DECSYSTEM 2020'S

BY: BOB ZOLTOK
TORONTO

The BUILD.MEM file that is distributed on the TOPS-20 distribution tape is in error with regard to rebuilding TOPS-20 for the 2020.

The changes are as follows:

- 1) On Page 5, Section 2.2., Step 2, there are parameter files for the 2020. Thus, the documentation should read:

STANDARD MONITOR

ARPA MONITOR

.
. .
. .
. .

No changes

"BIG"=PARBIG.MAC
"2020-SMALL"=P2OSML.MAC
"2020-MEDIUM"=P2OMED.MAC N/A

- 2) For Step 3, the name files for the 2020 are incorrect. The documentation should read:

2020 MONITOR

N/A
N/A
N/A
N/A
N/A
"2020-SMALL" = N2OSML.MAC
"2020-MEDIUM" = N2OMED.MAC N/A

NOTE: Please note that this article was originally published in
The Large Buffer - Vol. 430, 19 Oct 78

COMPANY CONFIDENTIAL

DMT ON THE DECSYSTEM-2020

BY: TOM DUNDON

MR1-2/E18

The DECSYSTEM-2020 recently completed rigorous design/quality testing, known within Digital as Design Maturity Testing (DMT). The 2020 is the first machine produced by the Large Computer Group to undergo this extensive testing.

Goals of the five-month DMT program were as follows:

- Demonstrate that the reliability of the hardware equaled its theoretical calculated reliability as established by standards such as MIL-STD-217.
- Determine what specific deficiencies in components, microcode, logic design, and software needed correction before volume shipments to the field could commence.
- Demonstrate that the design would operate satisfactorily over a prolonged period of time under the environmental, power, and margin conditions specified for the machine.

Six DECSYSTEM-2020's were chosen for DMT; they accumulated 15,000 unit hours of system operation during the test period. The six machines were run in an environment which, according to procedure, recorded marked fluctuations in temperature, humidity, and power.

At various times during the 2020's DMT, machines were adjusted to extremes of clock-frequency and DC voltage to establish sensitivity of component tolerances. Included in this testing was UNIBUS voltage margining. Incidentally, margin testing produced no evidence of problems requiring changes. It did, however, find some weak components and is now a standard part of manufacturing checkout.

Concurrent with environmental testing and margining, all logic and memory modules were rotated among machines to determine if any module was sensitive to a particular combination of other modules. This is an important maintenance question. No such sensitivity was found.

The software environment in which the above test program was conducted consisted of running all diagnostic programs daily, rerunning the programs when problems were encountered, and running a rigorous System Acceptance Test program called "User Environment Test Program" (UETP) when diagnostics were not run. UETP runs multi-stream simulated user jobs in all popular DECSYSTEM-20 languages. For DMT, UETP was parameterized to produce a very high system load to stress I/O interference and interrupt handling as would exist in extremely busy user sites.

COMPANY CONFIDENTIAL

Design Maturity Testing enabled Digital to discover and rectify dozens of minor and a few significant problems in the hardware, software, and microcode before the 2020 reached the Field. The approximate distribution of problems was: software 28%, microcode 25%, components 33%, other hardware 10%, and process 3%.

DMT resulted in a machine who projected reliability exceeds the calculated value based on MIL-STD-217. A follow-on program, known as PMT (Process Maturity Testing), is currently underway in the manufacturing area. Its purpose is to assure that the designed-in reliability of the 2020 is maintained in production on an on-going basis.

The DMT program for the 2020 was a joint effort of the Large Computer Engineering Group in Marlboro and the Corporate Reliability Engineering Group in Maynard.

NOTE: This article originally appeared in Sales Update/Vol. 10 No. 9

SURPRISE!!!

Effective January '79 issue of GOODSTUFF you will not only be receiving your personal hard copy of GOODSTUFF but it will also be incorporated into microfiche (Speed Bulletin).

NOTE: Speed Bulletin is published weekly, therefore GOODSTUFF should appear on fiche either the 3rd or 4th week of each month.

HOPE IT HELPS!

GOODSTUFF DISTRIBUTION

ADDITIONS: Send a TWX or memo stating that you wish to be added to the Goodstuff distribution list - your name, badge, c.c., and location code.

DELETIONS: Return the label from the envelope you receive Goodstuff in stating you wish to be deleted.

CHANGES: Changes can also be made to the distribution list by returning the mailing label with the appropriate change/s written directly on the label.

NOTE: IT IS VERY IMPORTANT THAT YOU DO INFORM US OF ANY CHANGE IN CC, LOCATION, ETC., SO AS YOU CONTINUE TO RECEIVE GOODSTUFF AND ALSO TO KEEP OUR LIST UP-TO-DATE.

Please forward this information to:

Nancie Mitchell - MR1-1/S35
Twx code: MR11

COMPANY CONFIDENTIAL

GOODSTUFF INDEX - 2ND QTR.
FISCAL YEAR 79

ISSUE NO. 12

- REWARD
 - GOODSTUFF DISTRIBUTION
 - LSG FIELD SUPPORT REORGANIZATION
 - PH2DNA UPDATE
 - UNEXPLAINED DEC-20 FRONT END RELOADS
 - RSX20F STOP CODES
 - DECSYSTEM 20 CABLE INFORMATION SHEET
 - ESTABLISHING KLINIK CONNECTIONS FOR REMOTE DIAGNOSIS
 - RPO4 AND RPO6 OFF-LINES
 - KMC11 SWITCHES
 - LP14 PRINT PROCESSOR BOARD
 - LSG FIELD SUPPORT REORGANIZATION
-

GOODSTUFF INDEX

SECOND QTR. - F.Y. 79

ISSUE NO. 11

- KL10 BASED DECSYSTEM 20 INSTALLATION MANUAL
 - RPO6 AND RMO3 DATA SHEET ERRORS
 - RPO6 HEAD ALIGNMENT FOR KS SYSTEMS
 - TOPS20 MEMORY PROBLEMS
 - TEMPORARY FIX FOR PVFU (DAVFU)
 - REVISED DECSYSTEM 2020 SITE PREP AND ENVIRONMENTAL REQUIREMENT
 - DN87 UPGRADE
 - THE TEN COMMANDMENTS OF SPARES HANDLING
 - CORRECTION - RPO4/5/6 DIAGNOSTIC FAILURE - FALSE "OPI'S"
-

GOODSTUFF INDEX

SECOND QTR. - FY 79

ISSUE NO. 13

- HAVE YOU CHECKED YOUR CAREER PATH LATELY?
 - DEPOSIT/EXAMINE FAILURES
 - DGKBB KL10 MEMORY SYSTEM DIAGNOSTICS
 - SOFT ERROR BAD SPOTS
 - LET'S GET OBJECTIVE
 - LP07 PRINT QUALITY WITH MULTIPART FORMS
 - ADDITION TO "HOW TO GET DATA ON INTERMITTENT EBUS PARITY ERRORS"
 - PM CHECK - 728 POWER SUPPLY
 - HOW TO GET A REAL SNAP-SHOT OF A KL10 SYSTEM - VER II
 - IME STOPCODES WITH SCHEDULER LIR
 - STOCKROOM 126 RETURNS
 - KL10 MODEL B SITES - MICROCODE VERSION 212.
 - DFRHB FAILURES
 - MORE DFTUE FAILURES
 - BUILDING MONITORS FOR DECSYSTEM-2020'S
 - DMT ON THE DECSYSTEM 2020
 - SURPRISE
 - GOODSTUFF DISTRIBUTION
-

WISH ALL OF YOU

A WONDERFUL HOLIDAY SEASON AND

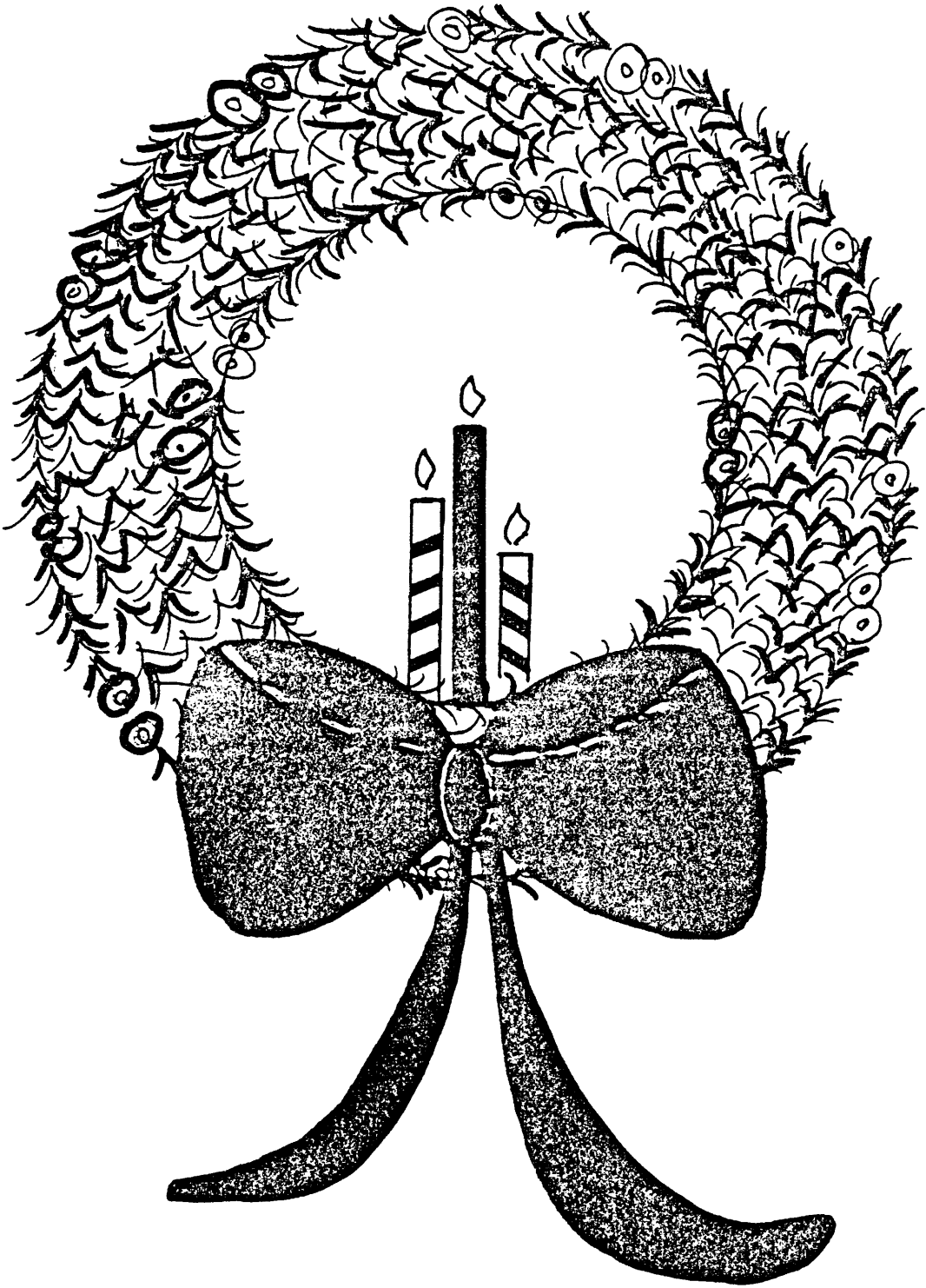

WE IN L.C.G. PRODUCT SUPPORT

A HAPPY NEW YEAR TOO !!!

GOOD STUFF

This document contains sensitive information which shall not be disclosed to personnel outside of Digital Equipment Corporation.

This Newsletter is meant as an information document. It's contents are not necessarily Company Policy. It's a means by which LCG Product Support can distribute some tidbits of information to you.

ISSUE NO 14 ... JANUARY-FY79

TOPS-10 SWAPPING ON DUAL PORT
DISK DRIVES

BY: JACK WALDEN
LCG PRODUCT SUPPORT
APPLICAIONS/TOOLS

If you have a site that is running the 6.03 monitor and trying to swap on a dual-ported disk drive having an RH10/RH20 on each port, then you have a site that is having extensive disk off-line problems. The 6.03A monitor has the necessary fixes to handle these problems, but until it is released the best you can do is have all swapping done on a disk that is single-ported to the -10.

This can be done by locking a drive to either port A or port B or by having swapping setup on the disk drive that has the RH11 and RH10/RH20 on it--since the 11 does no swapping.

COMPATIBILITY OF M8556 MODULES

BY: HERMAN MILLET
LCG PS QUALITY ASSURANCE

There are currently two revisions of the M8556 module available today. These revisions are:

"D" and "E"

Both of these revision M8556 modules are completely upward and downward compatible in all system revision levels which exist in the field today.

COMPANY CONFIDENTIAL

MB20'S CONTROLLER SELECTION

BY: GRAHAM MORLAND
LCG PS QUALITY ASSURANCE

Recently, Manufacturing discovered some MB20's with their controller selection reversed. Also, one report fed back indicates the problem has filtered into the Field.

The monitor and diagnostics run okay under a no-fault condition. However, if a memory problem exists, the diagnostics will indicate the controller it logically see's which will not be the controller you perceive it as seeing.

The controller selection is hardwired on the MB20 backplane. The correct selection is as follows:

	<u>PIN EF1</u>	<u>PIN EF2</u>	<u>SLOT</u>
C0	GND	GND	26
C1	--	GND	29
C2	GND	--	26
C3	--	--	29

The GND connection will be made to any convenient C2 or T1 pin.

Cross-Reference: MA/MB20-TT-1 (REV B)

1

DSTUB

BY: CARY DEVAN
LCG PRODUCT SUPPORT

<p>EDITORArt O'Donnell ASSOC. EDITOR...Nancie Mitchell EDITORIAL OFFICEMR1-1/S35</p> <p>GOODSTUFF is published on a monthly-basis.</p>
--

There is a problem with DSTUB which will be corrected in a later release of diagnostics.

When you run DSTUB you have to be careful to answer the question, "TEST RH# OR DEV:" with a "3". If you don't, your TU45 will give you tape write errors.

Cross Reference: 2020 DIAG-TT-1

COMPANY CONFIDENTIAL

GETTING LOGGED INTO [1,2] ON TOPS10

BY: RICK ELLISON
ROCKY MOUNTAIN DISTRICT SUPPORT

Have you ever needed to get logged into [1,2] and not known the password, or having just refreshed the disks, reloaded the monitor for some reason? If so, the following procedure can be used to get logged into [1,2] when bringing up a monitor. It relies on the fact that the disk refreshing code makes the assumption that if you refresh (i.e.: write a virgin file structure on) the disk, you must have just refreshed the system disk. As a result you will not have any files (i.e.: LOGIN, ACCT. SYS, etc.) with which to get logged in. To solve that problem, the refresher sets a flag to remember there is no LOGIN available. This flag contains the PPN into which the CTY will be "LOG"ed into when "LOGIN" is typed on the CTY.

Via BOOTM:
BTM> filespec/START:401
EDDT
REFLAG [Q 1,,2 ↵
400 \$ G
WHY RELOAD etc.

VIA BOOTS: filespec /L
/401
/G
EDDT
REFLAG [Q 1,,2 ↵
400 \$ G
WHY RELOAD? etc.

NOTES:

1. There must be two (2) commas between the 1 and the 2 to indicate that the 1 goes in the left halfword - not as an accumulator specification which would turn on bit 12.
2. " \$ " is ESCAPE.
3. " ↵ " is carriage return.
4. "filespec" is the monitor you want.

COMPANY CONFIDENTIAL

CAN'T ACCESS SYSTEM PACK?

BY: JACK WALDEN
LCG PRODUCT SUPPORT
APPLICATIONS/TOOLS

TU72 PHOTODIODE (FOR COLUMNS) OUTPUT COMPENSATION ADJUSTMENT

BY: JOHN A. LUTJEN
FIELD SERVICE - NEW JERSEY

There is an ECO in the TU72 "TV" Module (slot C2) which adjusts column photodiode output to compensate for aging in the fluorescent bulbs (they become dimmer).

Procedure for adjusting:

- No tape in columns.
- Put probe on C2 A27.
- Adjust top pot to 9.8V (TV Board)
- Put probe on C2 B27.
- Adjust bottom pot to 9.8V (TV Board).

The above information was supplied to me by Larry Burke - P.S. Marlboro. It was not found in the TU72 manuals.

If your TU72 loses vacuum on a hi-speed rewind, check this adjustment.

This adjustment should also be checked as a periodic PM Procedure.

Cross Reference: TU70/71-TT-14.

On TOPS-10 KL Systems, there are times when the RH20(s) can get into a state that requires a massbus init before the RH20(s) will accept commands. Usually, you will get a system after a crash or power fail and be told that the system pack cannot be accessed. If this happens, try the following RSX20F commands before doing anything else and then try and bring up the monitor.

RESET ALL <CR>
RESET IO<CR>

Now try loading the monitor.

Oh yes, TOPS-10 version 6.03A (soon to be released) and 7.01 have a fix for this problem.

NUMBERING YOUR BOOTS

BY: BOB MALONEY
LCG PRODUCT SUPPORT

After a boot failure on a DEC 2020 a number is printed. At this time, this feature is not supported.

When version three is released the boot failure number will have meaning. KSREF located on the RED PACK will have bit definitions.

COMPANY CONFIDENTIAL

CREATING A KLDCP BOOTABLE DECTAPE OR FLOPPY

BY: ROY SEQUEIRA
KANATA

This is an easy procedure to create a bootable DECTape or floppy. It assumes your output medium is okay.

We will use DECTape as an example--if you wish to create a floppy, substitute RX wherever DT appears in the device specification. I will also assume we are already in KLDCP. Type in the following:

```
P KLDCPU$                ;where $ is the "escape" key
                          ;this gets us into KLDCPU
DATE DD-MM-YY           ;enter todays date
ZERO DT0:                ;starts with a clean DECTape
SVBOOT DT0:<RPO:KLDTBT:BIN ;this puts the boot on the
                          DECTape
PIP DT0:KLDCP.BIN<RPO:KLDCP.BIN ;this must be the first file
PIP DT0:FILNAM.EXT=RPO:FILNAM.EXT ;now PIP over the other files
                          needed
```

Finally, get the directory of your new DECTape by typing:

```
DIR DT0:
```

Test the new DECTape by typing in:

```
BOOT DT0:
```

If you are now back to KLDCP after the DECTape stops spinning you have a good DECTape.

I would suggest keeping such a DECTape on site with all the files necessary for the BT command. This makes it unnecessary for the operator to ever put a KLAD pack on a write-enabled drive. This is of particular importance when the DDC has to dial in before DEC gets on-site. Another good file to have on an easily bootable medium is CRASH.CMD.

COMPANY CONFIDENTIAL

DDRPI PAKINT BAT BLOCK PROBLEMS

BY: JACK WALDEN

LCG PRODUCT SUPPORT - APPLICATIONS/TOOLS

If your sites are using DDRPI version 4 then you will see lots of disk off-line problems with TOPS-10 and swap error problems with TOPS-20.

Version 4 of DDRPI does not mark one word (called BAYNBR in TOPS-10 and BTHCT in TOPS-20) in the bat block when mapping is done. The net effect of this is that neither TOPS-10 nor TOPS-20 know about any bad spots found by DDRPI.

The solution to this problem is two-fold. The first, and long-term solution is to be sure that DDRPI version 6 is on its way to your site on the diagnostic distribution tape or to special order version 6 using the latest diagnostic index (orange microfiche).

The second, and most immediate solution is to follow the patching procedure below and using the patched/fixed version of DDRPI setup a schedule of reformatting all disk packs at your customer sites. The time and effort spent will significantly reduce the disk off-line/swap error problems at these sites.

PATCHING PROCEDURE:

Notes: The following symbols are used and have the meaning shown:

- <CR> - Carriage Return
- <TAB> - Tab Key (in DDT this means go to the address in the right half of the location you are examining).
- / - Slash Key (in DDT this means display the contents of the given address).
- 0 - Zero.
- ↑ - Control Key (used at same time as some other key, i.e.: ↑C is Control C).
- = - Equal Key (in DDT means give octal value of location examining or type value of specified symbol or type value of equation).
- [TEXT] - Comments by the author.

Cont. next page →

COMPANY CONFIDENTIAL

1. Log into your maintenance area:
 - a. You cannot have OPR or 1,2 privileges.
 - b. Verify that DIAMON.EXE, SUBTRN.A10, KLDDT.A10, and DDRPI.A10 are in your area.
2. Type only those items in the "Your Response" column.
3. For TOPS-20 systems only, do the following commands and pick up below starting at the system response "DDT".

COMMANDS

USER MODE -

```

RU DIAMON <CR>
DDRPI      <CR>
↑C ↑C
DDT        <CR>

```

[Now go to the "Your Response" below at the "DDT" "System Response" line].

SYSTEM RESPONSE

YOUR RESPONSE

HELP?	RU DIAMON <CR>
DIAMON CMD -	<CR>
TTY SWITCH CONTROL?-0,S,Y OR N <CR> -	DDRPI <CR>
LIST THE PGM SWITCH OPTIONS?Y OR N <CR>-	N <CR>
DDT	N (CR)
AC4	137/
MOVEI AC1	-1<CR> 36615/ <i>36611</i>
ADD 57467	SETZM 0 <CR> 36637/
67467 / READ #	<TAB>
1000,,0	=
	1001,,0 <CR>
	↑Z

[Now save the patched DDRPI]

SAVE DDRPI.FIX <CR>

[Now check your work]

DIAMON CMD -	RU DDRPI.FIX <CR>
-1	DDT <CR> 137/
SETZM 0	<CR> 36615/
ADD 67467	<CR> 36637/
67467/READ# 0 (AC1)	<TAB>
1001,,0	=
DIAMON CMD	<CR> \$G
TTY SWITCH CONTROL?-0,S,Y OR N <CR> -	STD

[CONGRATULATIONS you now have the fixed DDRPI that will save you a lot of grief]. *your name in DDRPI*

COMPANY CONFIDENTIAL

2020 TECH TIPS
BY: RICK GRADY
M.E.G.

With an attempt to keep the 2020 tech tips organized, the divisions designated below have been established. Therefore, when writing a tech tip about the 2020 you should address it to one of the following areas:

- 2020 - KS10
- 2020 - RH11C
- 2020 - RM03
- 2020 - RP06
- 2020 - TU45
- 2020 - DZ11
- 2020 - LP20
- 2020 - LP05
- 2020 - LP14
- 2020 - KMC11
- 2020 - DUP11
- 2020 - CD20
- 2020 - H7130
- 2020 - H7106
- 2020 - DIAGNOSTICS
- 2020 - RED PATCHES
- 2020 - UETP

DECSYSTEM-20 SITE LAYOUT KIT
BY: GRAHAM MORLAND
LCG P.S. QUALITY ASSURANCE

There is an error on Page 5 of this document. It shows a 50-foot device cable to the CD20-B (CRO4).

The maximum supported device cable for this device is 25-foot.

NOTE: Have contacted Tech Doc to ammend this error.

863 POWER CONTROLLER
BY: DON WERTH
LCG PRODUCT SUPPORT - WINGS

There are two versions of the AC low voltage detector as follows:

VERSION MODULE USED ON

A	W516	60 HZ 10'S
B	W516	50 HZ 10'S
D	W516YA	60 HZ 20'S
E	W516YA	50 HZ 20'S

NOTE: They are not interchangeable.

COMPANY CONFIDENTIAL

DECSYSTEM-10 WITH KL10 I/O PAGE FAIL ERROR/S...COP

BY: PAUL CLARK

IN HOUSE SUPPORT

I have been involved with the I/O Page Fail Error problem on two DECSYSTEM-10's. I have also conferred with other Support Engineers who encountered this problem on other machines.

The most obvious symptoms have ranged from simple "DECSYSTEM-10 not running" statements on the CTY (with no cause given) to the CTY output of 41 successive "CPU0 Stop Code COP - Continuing Monitor" followed by a hang.

In all cases, a "TRACON" or "SYSERR" dump showed the "I/O Page Fail Err In" and/or "I/O Page Fail" Flop were true.

By definition, "I/O Page Fail Error" indicates that an AR or ARX parity error has been detected during a P1 cycle.

A pertinent fact is that, when an AR or ARX parity error is detected during the P1 cycle, the microcode stores in AC block 7:

- a) In location 0 - The contents of the AR
- b) In location 1 - The contents of the ARX
- c) In location 2 - A Page Fail Word containing a code which gives the reason for the I/O Page Fail (see KL10 Maintenance Handbook EK-KL10-HB-001 page 33).

In all cases in which I have been involved, the code in AC Block 7 location 2 was a "36" indicating bad parity in the AR.

Some print set study shows that for parity within the AR to be meaningful, for data received from the EBUS during the P1 cycle, it is necessary for the signal "EBUS Parity Active" to be true. Further study reveals that of the devices present on the EBUS (DTE-20's, RH20's, and DIA) only the DTE's are capable of generating "EBUS Parity Active".

These facts surely single out the DTE-20's as the most likely candidates for the cause of I/O Page Fail Errors. Moreover, in all cases which I observed and in those which I discussed with other engineers, one or another of the DTE-20's was found to be the cause of this problem.

In one particular instance where no CTY output other than "DECSYSTEM 10 Not Running" was observed, DTE#0(Master) was causing the I/O Page Fail. In this case, the ten was not able to give us the expected "COP" Stop Code because he was in an I/O Page Fail Loop trying to output to the failing master DTE. Specifically, the M8552 was failing by dropping Bit 35. This module was speed-sensitive in that it would not fail diagnostics in the 30 MHZ machine but did fail, when tested later, in a 25 MHZ system. The system in which the problem occurred was a 30 MHZ machine and, though diagnostic failures were not evident, monitor crashed every 10-hours or so.

COMPANY CONFIDENTIAL

IN SUMMATION:

Though it is unlikely that ALL I/O Page Fail Errors or COP Stop Codes will turn out to be DTE related, it is clear that the DTE-20's should command early attention.

BIG NOTE:

If this memo is to be meaningful to you in terms of a solution to a problem you MUST have the following symptoms:

1. "I/O Page Fail Err" or "I/O Page Fail Err In" true in a TRACON or a "GOOD" SYSERR dump.

AND

2. A Page Fail Code of "36" stored by the Microcode in AC Block Location 2.

P.S.:

1. Present:

TOPS10 603 does not save AC Block 7. In order to Retrieve this information you must use KLDCP.

2. Future:

TOPS10 701 promises to save AC Block 7 for us in the Crash.exe Dump.

3. Other Possible Causes:

Any component in the Data Patch between the DTE20 and the AR, i.e.: M8516 (EBUS translator); frayed cables between I/O bay and CPU bay; pollution of the EBUS by some other device or module.

COMPANY CONFIDENTIAL

TOPS10 CTY FILL CLASS SETTINGS

BY: RICK ELLISON

ROCKY MOUNTAIN DISTRICT SUPPORT

When going through the ONCE only dialogue, do you wish the CTY default filler class were zero?

If so, the following procedure will allow you to solve that "slow carriage return on LA36" frustration.

If you are already in the ONCE only dialogue, all that is necessary is to stop the CPU (as appropriate for the hardware you have at hand), and then start the machine at location 401. This will place you into EDDT. If you have not loaded your monitor yet, one of these techniques could be followed:

FOR BOJIS
type in:

filespec/L
/401 {load and }
/G {start EDDT}

FOR BOOTM
type in:

filespec/START:401

Now, no matter how you got here, you are ready to make life faster. To EDDT type the following (as usual EDDT's output to you is underlined).

OPRFIL/ ANDI T3.DLC2#+13 = 405400.177 POPJ P, ↵

400 Ⓢ G

You are now back to the WHY RELOAD question.

NOTES: " Ⓢ " is ESCAPE key; " ↵ " is carriage return

If you want to change the fill class for the CTY at MONGEN time, define the following values during the DECIMAL or OCTAL values part of HDWGEN:

CTYDCR,0
CTYDLF,0

These will provide no delay for either carriage return or line feed.

You can permanently patch OPRFIL via this mechanism (others will work just as well):

Cont. next page →

COMPANY CONFIDENTIAL

login into 1,2

type the following:

_R FILDDT
FILE:filespec/S
FILE:filespec/P

OPRFIL / ANDI T3.DLC2#+13 = 405400.,177 POPJ P, 2

Ⓢ

NOTE: Ⓢ is the control - Z key.

In all of the above "filespec" is the necessary file specification for the monitor you want.

One last item regarding CTY fillers on KL10 systems under KLDCP and diagnostics. The KLDCP command as follows will set the fillers to zero for LA36's.

Σ. TF 0
Σ.

MODULE REPAIR TAGS

BY: ART O'DONNELL
LCG PS QUALITY ASSURANCE

LP07 INTERMITTENT TOF PROBLEMS

BY: B.NEWSTROM/G.PICKLE
MINNEAPOLIS

A recent review of modules returned to Marlboro for repair found that 65% of the modules had no pertinent fault data on the tags--many say simply, "BROKE".

Please provide as much failure information as possible on the module repair tags:

1. If DOA - Indicate how failure was detected and how long it ran; i.e.: immediately, after 1-hour, etc.
2. Indicate failure type - solid or intermittent diagnostic, or monitor or exerciser. Include diagnostic name, subtest, PC, etc.
3. Indicate backplane slot module fails in.
4. If only suspected as bad, status unknown, out of rev, etc., please indicate.

If forms on LP07 are stopping one line short intermittently, do the following:

1. Program maintenance switches to print one line and do a TOF. Lines will appear to creep upwind on the form.
2. Grasp line strobe unit (to right of paper path) and pull to increase the tension on the small belt driving this item. If the line "creeping" stops, replace this belt.

This problem has been seen at several sites and the belt in question shows no apparent damage.

Cross-Reference: LP07-TT-3.

Thanks for your help!

COMPANY CONFIDENTIAL

ERROR IN KL10 MAINTENANCE HANDBOOK

BY: BILL HILLIARD
LCG PRODUCT SUPPORT
DATED: 6-27-78

The DMA/DIA/DTE MUL found on Page 87 of the KL10 Maintenance Handbook is in error. It should read (for slots 4-11):

<u>SLOT</u>	<u>DESCRIPTION</u>
4	K0,D00-D17, ADR 14-23, RQ CYC TYPE, MA (I=0,N=0)
5	K0,D18-D35, ADR 24-33, MEM CYC TYPE,MA (I=0,N=1)
6	K1,D00-D17, ADR 14-23, RQ CYC TYPE, MA (I=1,N=0)
7	K1,D18-D35, ADR 24-33, MEM CYC TYPE,MA (I=1,N=1)
8	K2,D00-D17, ADR 14-23, RQ CYC TYPE, MA (I=2,N=0)
9	K2,D18-D35, ADR 24-33, MEM CYC TYPE,MA (I=2,N=1)
10	K3,D00-D17, ADR 14-23, RQ CYC TYPE, MA (I=3,N=0)
11	K3,D18-D35, ADR 24-33, MEM CYC TYPE,MA (I=3,N=1)

Through requests we decided to publish the above article -- it can also be found on KL10-TT-50.

GOODSTUFF INDEX

3RD QTR. - FY 79

- TOPS-10 SWAPPING ON DUAL PORT DISK DRIVES
- COMPATIBILITY OF M8556 MODULES
- MB20'S CONTROLLER SELECTION
- DSTUB
- GETTING LOGGED INTO [1,2] ON TOPS10
- TU72 PHOTODIODE (FOR COLUMNS) OUTPUT COMPENSATION ADJUSTMENT
- CAN'T ACCESS SYSTEM PACK?
- NUMBERING YOUR BOOTS
- CREATING A KLDGP BOOTABLE DECTAPE OR FLOPPY
- DDRPI PAKINT BAT BLOCK PROBLEMS
- 2020 TECH TIPS
- DECSYSTEM 20 SITE LAYOUT KIT
- 863 POWER CONTROLLER
- DECSYSTEM 10 WITH KL10 I/O PAGE FAIL ERROR/S...COP
- TOPS10 CTY FILL CLASS SETTINGS
- MODULE REPAIR TAGS
- LPO7 INTERMITTENT TOF PROBLEMS
- ERROR IN KL10 MAINTENANCE HANDBOOK

GOOD STUFF

This document contains sensitive information which shall not be disclosed to personnel outside of Digital Equipment Corporation.

This Newsletter is meant as an information document. It's contents are not necessarily Company Policy. It's a means by which LCG Product Support can distribute some tidbits of information to you.

ISSUE NO 15 ... FEBRUARY—FY 79

MF20 ADD ON MOS MEMORY REQUIREMENTS

BY: ART O'DONNELL
LCG PS QUALITY ASSURANCE

There are two hardware restrictions that you should be aware of when planning for the installation of MF20 MOS memory on a DEC SYSTEM 20.

1. The currently installed CPU must be a Model B processor (KL10-E). If this is not the case, the customer will require a KL10-PV kit upgrade as part of his MOS memory add on. You should insure your salesman has ordered a KL10-PV as part of the upgrade if your customer has a Model A processor (KL10-C).
2. Your DEC SYSTEM 20 integral revision level must be revision 4. (Full details on revision 12/4 will be released in a special issue of Goodstuff to be published the 1st of March.)

The installation of add on MOS memory will require a pre-installation check (hopefully prior to your Branch Manager signing the Master Order Form) to determine CPU type and revision level. Once determined, a plan for CPU conversion and FCO installation, if needed, should be established.

Assistance can be obtained by calling the LCG Product Support Technical Assistance Center - phone #: 617-481-9511 or DTN: 231-6903.

KL10 MAINTENANCE GUIDE
SEE PAGES 3 & 4 FOR INFORMATION ON:
"HOW TO ORDER YOUR KL10
MAINTENANCE GUIDE"

COMPANY CONFIDENTIAL

SPURIOUS MEMORY PARITY ERRORS

BY: JACK WALDEN
LCG PS - MARLBORO

If you try to put memory on-line during TOPS-10 timesharing via the set memory on-line command, it is possible to get a false memory parity error. Since it is new memory (i.e.: new stack) it is possible to have parity set up wrong. Thus, when the memory is put on-line, the bad parity is found and the false parity error reported.

MCO #8133 which is in the 603A monitor will fix this problem. If you use this method of putting memory on-line, you should have this MCO installed in the monitor.

IN KLSER AND KISER

AT MEMO10	CHANGE	MOVES	.EUPMP-1 (T3)
	TO	SETZM	.EUPMP-1 (T3)
AT MEMO10+1 1/2	INSERT	MOVEI	T4, NXMDLY
	BEFORE	TDNN	T2, NXMTAB## (T1)

Cross Reference: KL10-TT-62

SYSERR

BY: DINO GENOVA
LCG PRODUCT SUPPORT

<p>EDITORArt O'Donnell ASSOC. EDITOR...Nancie Mitchell EDITORIAL OFFICEMR1-1/S35</p> <p>GOODSTUFF is published on a monthly-basis.</p>

This is just a reminder that you should be using SYSERR Ver. 12 or higher to ensure that the correct CRAM & DRAM information is collected at the time of a clock error stop.

COMPANY CONFIDENTIAL

KL10 MAINTENANCE GUIDES

BY: BOB SMITH

LCG COMM DEV. & PUB.

KL10 Maintenance Guides are now available! They are stocked by the Printing and Circulation Services Center located in Northboro, Massachusetts. The document number for the guide is EK-OKL10-MG-001. To obtain a copy, notify your local literature contact. He or she will process your order and insure that your name is entered on the distribution list for future updates.

The guide, originally referred to as the KL10 Maintenance Handbook, has been revised. It now consists of two 5 x 8 loose leaf volumes.

Volume I contains hardware maintenance information and is divided into five-sections:

- General Information
- Switches and Jumpers
- Tables and Maps
- Checks and Adjustments
- Diagrams and MUL's

Volume II contains software information. It is divided into two sections:

- Systems Software
- Maintenance Software

The System Software section briefly describes the organization of system software and summarizes the following operating systems and their corresponding system program libraries:

- RSX-20F
- TOPS-10
- TOPS-20

The Maintenance Software section briefly describes the organization and structure of maintenance software, and summarizes the utility and diagnostic programs in the following maintenance libraries.

- 8 - Based 8 (for TU70 sub-systems only)
- 10 - Based 10
- 11 - Based 10
- 11 - Based 11

The guide consists of two volumes because of the expanded scope and contents. Small (5 x 8) loose leaf binders were chosen for user convenience and updatability. Updates will include; corrections, additions, and recommended deletions.

CONT. NEXT PAGE

COMPANY CONFIDENTIAL

If your name is on the distribution list you will automatically receive a maintenance guide update package each time the Software Distribution Center (SDC) releases a new (revised) set of diagnostic tapes. This will occur approximately every other month.

Coordinating the maintenance guide updates with the SDC software release has two advantages:

1. Your maintenance guide will always reflect the latest maintenance software available.
2. Each time you receive a guide update, you will know a new diagnostic tape is available from SDC.

A pitch for feedback--We know you guys are busy out there and when the pressure is on it's tough. But if you come across something that you think will make the guide a better tool, tuck it away when you get a chance and drop it in the mail. The introduction in Volume I will tell you how to do it.

One last thing--the guide is considered "COMPANY CONFIDENTIAL".

DIAGNOSTICS ON DZ11 (DSDZA)

BY: JOSEPH BARNA
ATLANTA, GEORGIA

To properly check out all lines on the H317B you should use the following switch settings for diagnostic DSDZA. Left 011050 - Right 000111.

The writeups on this are less than explicit so just follow the dialogue. You will be able to enter all selectable parameters to check out each line individually.

IS YOUR FORCE RELOAD WIPING OUT
USEFUL DATA?

BY: CARY DEVAN
LCG PRODUCT SUPPORT

If you have a problem with DEC-System 2020 that looks like the force reload is wiping out useful data of the failure--You can set no reload by the following:

VERSION 0.1
LK 20255
DK 303

VERSION 0.2
LK 20256
DK 303

COMPANY CONFIDENTIAL

VT100 SUPPORT ON TOPS-10 AND TOPS-20

BY: ELBERT BLOOM
LSEG

I. CURRENT VT100 SUPPORT

1. Currently the VT100 is supported on TOPS-10 and TOPS-20. Operating Systems in VT52 compatibility mode only (i.e.: the VT100 must be manually configured to VT52 mode by the operator). In this mode the terminal may be used as a direct VT52 replacement except for the following incompatibilities:
 - a. The VT100 requires support of XON/XOFF at 9600 baud higher.
 - b. The VT100 base product has no printer interface.
 - c. The VT100 Graphic Symbols are different.
 - d. Operation of the VT100 SCROLL key is different.
 - e. The VT100 has no REPEAT key. Keys are auto-repeating instead.
 - f. A FORM FEED (14 g) is displayed as a LINE FEED (12 g) by the VT100, but is ignored by the VT52.
 - g. Different keys must be depressed on the VT100 in order to generate CTRL/@, CNTRL/^, and CTRL/- (see paragraph III below).
2. In addition the following ANSI (VT100) features may be used while the terminal is in VT52 compatibility mode by MANUALLY selecting them.
 - a. SMOOTH or JUMP SCROLL - CAUTION, see paragraph III below.
 - b. AUTO-REPEAT
 - c. Light or Dark Screen Background
 - d. Underline or Block cursor
 - e. Margin Bell
 - f. Keyclick
 - g. Auto XON/XOFF

CONT. NEXT PAGE

COMPANY CONFIDENTIAL

- h. U.S. or U.K. Character Set
 - i. 60 Hz or 50 Hz Power Operation
 - j. 80 column or 132 COLUMN MODE
 - k. NON-VOLATILE RAM
3. Any of the ANSI (VT100) features may also be used, with caution, via a Customer Applications Program as follows (reference paragraph III below):
- a. The applications program must initially set the terminal to the ANSI (VT100) mode. It may then utilize any of the ANSI ESCAPE sequences.
 - b. The applications program must then reset the terminal to the VT52 compatibility mode before exiting to the monitor.

II. SUPPORT OF THE VT100 IN VT100 MODE

"TOPS-20, RELEASE 4" and "TOPS-10, VERSION 701" will support the VT100 in VT100 mode (i.e.: the VT100 may be manually configured to VT100 MODE by the operator). The only difference as far as the system is concerned is that the MONITOR will control the terminal via the ANSI ESCAPE sequences instead of the VT52 CONTROL sequences.

All of the conditions in paragraph I above still apply except that the customer applications program will no longer have to configure the terminal to the ANSI (VT100) mode in order to access the ANSI features.

The same precautions which exist for the VT100 when used in VT52 compatibility mode also apply to the terminal when used in VT100 mode (see paragraph III below).

III.

- 1. SMOOTH SCROLL - If the terminal is being operated in the SMOOTH SCROLL mode it should also be operated at non split baud rates not exceeding 2400 baud. XON/XOFF must also be enabled.
- 2. Different keys must be depressed on the VT100 in order to generate the following CONTROL CODES. See the chart below.

<u>OCTAL</u>		<u>GENERATED BY DEPRESSING</u>	
<u>CODE</u>	<u>CHAR</u>	<u>VT52</u>	<u>VT100</u>
000	NUL	CTRL/@	CTRL/(SP)
036	RS	CTRL/^	CTRL/ ~
037	US	CTRL/_	CTRL/?

CONT. NEXT PAGE

COMPANY CONFIDENTIAL

3. It is recommended that the following VT100 parameters always be set as indicated below (see the VT100 USER'S GUIDE for details):

PARITY SENSE = 0
PARITY = 0
BITS PER CHAR = 1

4. VARIABLE TABS - The Variable Tabs feature of the VT100 is not being supported by the TOPS-10 or TOPS-20 MONITOR or any supported Applications Programs.

It is also recommended that user applications programs not use the Variable Tabs feature. The VT100 TAB settings should be set to the standard positions.

5. The following operator selectable features have no current use on TOPS-10 and TOPS-20 Operating Systems:

- a. Wrap Around
- b. New Line

6. If a VT100 and VT52, or any terminal other than a VT100, is being linked together via the MONITOR the VT100 should be operated in VT52 compatibility mode only.

7. For detailed information concerning any of the issues in this article refer to the "VT100 USER'S GUIDE".

IV. VT100 OPTIONS WHICH CURRENTLY MAY BE SOLD FOR USE ON TOPS-10 AND TOPS-20 OPERATING SYSTEMS

VT100-AA	115 VOLT Terminal
VT100-AB	230 VOLT Terminal
VT1XX-AA	20 ma Current Loop Option
VT1XX-AB	Advanced Video Option

COMPANY CONFIDENTIAL

DIAGNOSTIC DATA COMPARE ERRORS ON 1099

BY: JACK WALDEN
LCG PS - MARLBORO

If you have a 1099 system and try to run memory diagnostics in user mode, there is a very good chance that you will have false data compare errors.

To prevent this problem you should have MCO #7544 installed in the monitor. The MCO is given below:

IN SCHED1

AT FORCOO DELETE PUSHJ P,SWPCSH##
JRST (T2)

AT FORCE1 BEFORE SKIPN FORCEF

INSERT PUSHJ P,SWPCSH##
JRST FLGNUL

IN CPISER

AT SWPCSH+1 CHANGE POPJ P,
TO JRST CPOPJ1##

NOTE: Cross-reference KL10-TT-63.

RUNNING DDRPI ON
DUAL PORTED DRIVES

BY: ROBERT NOBREGA
IHFS - DISTRICT SUPPORT

When running DDRPI on a system with dual ported RP04 or RP06 drives that have an RH20 on each port, the diagnostic may fail to map the drives from both ports. This happens because the diagnostic does not issue a "release" command after it accesses the drive. Therefore, the drive cannot be seen from the other port until the "one second" port release timeout is over.

If this problem is encountered, the drives should be locked on the desired port before running this diagnostic.

DSXLA WITH TMO3

BY: CARY DEVAN
LCG PRODUCT SUPPORT

I have received several calls about using DSXLA on systems with TMO3's.

The correct tapes for Field Service are 1 and 3. <SUPPORT> These tapes are shipped with systems and Red Tape 3 has all the diagnostics on them.

If you want your own copy of Red Tape #3, this can be done by following the procedure in RED20.MEM - Page 6-2.

There can also be a problem with the software installation tape using TMO3's. This is a TMO2/TMO3 difference problem and not a hardware problem! Call your Software Support person.

COMPANY CONFIDENTIAL

DETERMINING KL PROCESSOR MODELS

BY: STEVEN H. PAINTER III/JACK WALDEN
PHILADELPHIA/LCG PS - MARLBORO

Occasionally the model of a KL10 processor is in question. There is an absolute, sure-fire way to determine the model type. Have Field Service start up KLDCP. Then type:

```
EX 700000    000002
EM 2
```

This will cause a read-APR-ID to be executed and display the results. If bit 21 is off the processor it is a model A; if on it is a Model B processor.

The whole word has the following meaning:

<u>BIT</u>	<u>MEANING</u>
0	KI PAGING IF ON (TOPS-20)
1	EXTENDED ADDRESSING
2	NON-STANDARD MICROCODE
8	SPECIAL DIAGNOSTIC MICROCODE
9-17	MICROCODE VERSION
18	50 HZ IF ON
19	CACHE
20	CHANNEL
21	MODEL B IF ON; ELSE MODEL A
24-35	APR SERIAL NUMBER

PLEASE NOTE:

1. THAT THE CONTENTS OF BITS 0-17 ARE SET BY THE MICROCODE.
2. THAT THE CONTENTS OF BITS 18-35 ARE SET BY THE HARDWARE.

COMPANY CONFIDENTIAL

PROCEDURE FOR ACCESSING AND/OR TRANSFERRING FRONT-END FILES

BY: ROY SEQUEIRA
REGIONAL SUPPORT KANATA

The procedure as given in Goodstuff #6 leaves some data out. This makes it impossible to access front-end files. I have put together a procedure that fills in the missing information, as follows:

Assume you have a new revision diagnostic you would like to have in the front end area of your TOPS20 KLAD pack. The file is now on your (timesharing) area <F-S>. Type in the following, after logging in:

```
TRANS$<F-S>                ;where $ represents "altmode"  
                             ;this gives the TOPS10 format  
                             PPN  
                             ;ie [L,R].  
ENA                          ;enable privileges.  
FE                            ;this starts the FE program.
```

Now go over to the console and login as OPERATOR. The following should be typed in on the console:

```
ENA  
FE  
"cntrl \"                   ;this gets PARSER  
M MOU                       ;starts the MOUNT program.  
FE:                          ;tells the MOUNT program to  
                             mount the front end.  
"cntrl Z"                   ;gets out of MOUNT  
"cntrl \"                   ;back to parser  
MC PIP  
DB?:[6,11]OLDNAM.EXT;#/DE    ;where ? = unit #  
                             ;where # = version #  
DB?:[6,11]FILNAM.EXT;1/NV=FEO:[340,PPN]FILNAM.EXT:0  
                             ;where ? = unit #  
                             ;where PPN = right hand number  
                             of translated directory
```

(NOTE: these instructions may also be found in KLAD20.MEM)!

This can also be used to transfer files between sites using floppies if you ask MOU to mount the appropriate floppy, DX0: or DX1:.

Feedback welcome -- send to:

ROY SEQUEIRA - KANATA TELEPHONE #613-592-5111 X2200 OR DTN: 621-2200

DISK OFF-LINE PROBLEMS
CORRECTED BY TOPS 10 603-A

BY: CLARKE T. WEGNER
MARLBORO SUPPORT GROUP/
SOFTWARE SERVICES

Disk off-line problems can be divided into three distinct classes of problems, all of which have the same symptom--the disk is reported as being "off-line" by TOPS-10. The three classes are:

1. Legitimate hardware errors that the software cannot recover from.
2. A legitimate hardware error that can be recovered via software but isn't.
3. A hardware error caused by the software issuing the wrong sequence of commands to the hardware.

There will always be hardware problems occurring in disk drives that will force the software to call the drive off-line. There is nothing that the software can do about this condition and it seems to represent a small fraction of the reported problems. We focused our attention on what type of error recovery TOPS 10 does when it realizes that an error has been reported on a disk drive. By examining the code and fault inserting the hardware, we found that while there are a number of errors in TOPS 10 version, 603 in this area, we are convinced that these errors have been corrected in version 603A and that many of the errors that caused off-lines on 603 will be completely recoverable when running 603A. Our experience also indicates that version 603A of TOPS 10 will not issue the wrong sequence of commands to the disk sub-system that caused the off-line conditions in the past.

Software Engineering, Software Support, and Field Service, have worked successfully together to produce TOPS 10, 603A, which has resolved all the known software disk off-line problems. We, therefore, expect the complaints voiced by our customers to dramatically decrease after they install 603A. As a result, any customers experiencing disk off-line problems must upgrade to 603A.

It must be emphasized that off-line will always be with us because they can be caused by non-recoverable hardware errors. Therefore, it is very important that regular maintenance, tape backup and disk refreshing are performed at the customer site.

BUGCHK-KPALVH
(ON 2020 SYSTEMS)
BY: JOSEPH BARNA
ATLANTA, GEORGIA

When the Redpack monitor auto boots, it automatically starts UETP unless modified. If after running "DSDZA" you happen to leave the H325 turn-around plug in the distribution panel (H317) in line 0 and auto boot the red monitor, it will crash with a "KPALVH".

This can definitely lead you down the garden path unless you keep it in mind. I suspect that you may have to modify Reliab-CMD as per instructions on page 12-7 of Red 20.Mem.

COMPANY CONFIDENTIAL

SYSERR BUG

BY: TED WOJCIK
M.E.G.

Now that Version 12A of SYSERR is in the Field, we have discovered a serious bug having to do with magtape error reporting. The bug causes SYSERR to "ILL MEM REF" while trying to report a magtape error.

A stopgap patch has been developed. The patch should be installed in SYSERR Ver. 12A on any system. The patch is as follows:

With SYSERR 12A on SYS:

```
.GET SYS: SYSERB
JOB SETUP
.DDT

VMDDT
411555/PUSHJ 17,.PPNWW
CHANGE TO
      PUSHJ 17,.TPPNW

↑Z
.SAVE
SYSERB SAVED
```

Move the corrected SYSERB to SYS. This will fix the ILL MEM REFS. However, if an older version of DAEMON is being run then, the User PPN and Program name reported by SYSERR will be incorrect. The only fix for this is to run the proper DAEMON.

H760 POWER SUPPLY CAPS

BY: DON WERTH
LCG PRODUCT SUPPORT

If the need arises to replace the primary tuning capacitors (C5, C6, C7 - 12 uf 560 VAC) referenced by Item #3 in the parts list, they can be ordered under:

STOCK #10-11729-01

LP07 CHARABAND EXTENDED LIFE

BY: BERT LONGO
M.E.G.

Would you like to extend the charaband life! If so, when the printer is not operational, leave the baud gate in the open position.

COMPANY CONFIDENTIAL

NECESSARY PATCHES FOR RELEASE 3A CHECKD

BY: DAVID BELL

MR1-2/S43

Release 3A of CHECKD was sent out with a serious bug. CHECKD does all of its BAT block logic incorrectly. Thus, if you try to recover lost pages, BAT blocks will be freed and will be reused. The following patches fix this and other similar problems, and should be installed at all sites. All of these patches will be in Release 4.

Problem 1 (Release 3A only)

CHECKD releases blocks marked in the BAT blocks. This was caused in Release 3A by the insertion of a word of data in the middle of a block of data which is copied from other places using a BLT. Therefore, the wrong value is stored into one of the variables.

LINE 52, PAGE 3

1) HFLAGS: BLOCK 1 ;FLAGS FROM HOME BLOCK
1) LPPCYL: BLOCK 1 ;LOST SECTORS PER CYL

LINE 53, PAGE 3

2) LPPCYL: BLOCK 1 ;LOST SECTORS PER CYL

LINE 50, PAGE 4

1) LOSTOT: BLOCK 1 ;NUMBER LOST PAGES

LINE 60, PAGE 4

2) HFLAGS: BLOCK 1 ;FLAGS FROM HOME BLOCK
2) LOSTOT: BLOCK 1 ;NUMBER LOST PAGES

Problem 2 (Release 3 and 3A)

CHECKD releases pages that belong in the BAT blocks. The problem is that the BAT block addresses were assumed to be 18-bit addresses, whereas--the field is actually 27-bits. Thus, BAT entries which described high disk addresses were incorrectly used. Only RP06 packs have enough storage to show the problem.

LINE 36, PAGE 55

1) NXTPR: HRRZ T4,1(T3) ;GET START ADDRESS
1) ADD T4,Q1 ;MAKE IT A LINEAR ADDRESS

LINE 36, PAGE 55

2) NXTPR: LOAD T4,ADD27,(T3) ;GET STARTING ADDRESS IF NEW
FORMAT
2) LOAD T1,BADT,(T3) ;GET TYPE FIELD
2) SKIPN T1 ;OLD FORMAT?
2) LOAD T4,ADD18,(T3) ;YES, GET OLD STYLE ADDRESS
INSTEAD
2) ADD T4,Q1 ;MAKE IT A LINEAR ADDRESS

NOTE: This article originally appeared in The Large Buffer, Volume 443, 18 January 1979.

COMPANY CONFIDENTIAL

CACHE PATCH FOR 1091s

BY: ALLAN WILSON/ED MCHUGH
MR1-1/M85

While working with the 1091, we have been using a patch that takes full advantage of the KL cache. The patch keeps the entire monitor data base cached and eliminates cache sweeps.

CHANGE IN KLSER

CSDMP: from PUSHJ P,SAVT
 to POPJ P,

CHANGE IN SYSINI

KIIN9A: from SETZ P1,
 to JRST KII10A (P2)

We believe all 1091 sites should use this patch. It will make a noticeable improvement in system behavior.

1091s with NO external memory port devices (e.g.: DX10, RH10, DA28, DT10C, etc.) can use this patch as well.

NOTE: This article originally appeared in Large Buffer, Vol. 433, 9 NOV 78.

GOODSTUFF INDEX #15

3RD QTR - FY 79

- MF20 ADD ON MOS MEMORY REQUIREMENTS
- SPURIOUS MEMORY PARITY ERRORS
- SYSERR
- KL10 MAINTENANCE GUIDES
- DIAGNOSTICS ON DZ11 (DSDZA)
- IS YOUR FORCE RELOAD WIPING OUT USEFUL DATA?
- VT100 SUPPORT ON TOPS-10 AND TOPS-20
- DIAGNOSTIC DATA COMPARE ERRORS ON 1099
- RUNNING DDRPI ON DUAL PORTED DRIVES
- DSXLA WITH TMO3
- DETERMINING KL PROCESSOR MODELS
- PROCEDURE FOR ACCESSING AND/OR TRANSFERRING FRONT-END FILES
- DISK OFF-LINE PROBLEMS CORRECTED BY TOPS-10 603.A
- BUGCHK - KPALVH
- SYSERR BUG
- H760 POWER SUPPLY CAPS
- LP07 CHARABAND EXTENDED LIFE
- NECESSARY PATCHES FOR RELEASE 3A CHECKD
- CACHE PATCH FOR 1091'S

GOOD STUFF

This document contains sensitive information which shall not be disclosed to personnel outside of Digital Equipment Corporation.

This Newsletter is meant as an information document. It's contents are not necessarily Company Policy. It's a means by which LCG Product Support can distribute some tidbits of information to you.

ISSUE NO. 16

* * *

MARCH - FY 79

DFTUE B2 TEST VS. TOPS 20

REL. 3 AND 3A

BY: LARRY BURKE
LCG PRODUCT SUPPORT

2020 COMM

BY: PETER MARIE
M.E.G. - MARLBORO

Running DFTUE B2 test in user mode under TOPS 20 Release 3 or 3A can result in the loss of one or all tape drives until monitor is reloaded.

It is recommended that only DFTUK reliability diagnostics be run in user mode until this is fixed.

NOTE: Will keep you informed as to when fix will happen.

Experiencing problems with jobs not detaching when people hang up without logging out! The following patch will make sure those leftover jobs go away:

TTYSRV at CARNON+6

IS: TLNN CX,1000
CHANGE TO: TLNE CX,1000

RSX-20F NAMING CONVENTION

BY: DON WERTH
LCG PRODUCT SUPPORT

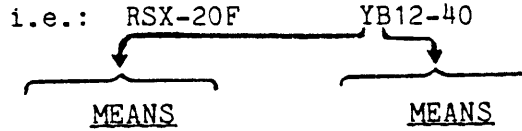

- | | |
|--------------------|------------------|
| X = EXPERIMENTAL | |
| Y = LOAD TESTED | O = UNIVERSAL |
| V = FORMAL RELEASE | A = TOPS-10 |
| | B = TOPS-20/ARPA |
| | E = 1091 |

NOTE: EXPERIMENTAL VERSION SHOULD NEVER FIND ITS WAY INTO FIELD!

MAINDEC-10-DCXLA.INP
VERSION 0.6

BY: RUSS MYERS/ROY SEQUEIRA
VANCOUVER - KANATA

EDITORArt O'Donnell
 ASSOC. EDITOR...Nancie Mitchell
 EDITORIAL OFFICEMR1-1/S35

GOODSTUFF is published on a
 monthly-basis.

The above tape will not run under MAGMON. This is because MAGMON assumes the first eight files on tape are in a specific sequence. This version of tape has the first six files correct. SUBRTN and KLDDT should be the next two files. THEY ARE NOT!

All that needs to be done is to TECO DCXLA.INP to include SUBTRN and KLDDT in the right places.

COMPANY CONFIDENTIAL

COMPONENT FAILURES OF PAPER PULLER ASSEMBLY

BY: BERT LONGO
M.E.G.

The LP14 paper pullers most frequent failures lie in the following components:

<u>DESCRIPTION</u>	<u>DEC PART NO.</u>	<u>DpC PART NO.</u>
Paper Puller Motor	29-23009-00	246716-001
20 Teeth Pulley	29-23261	800171-021
54 Teeth Pulley	29-23262	800171-022
Belt	29-23023	800617-006

The paper puller motor is marginally designed with the problem showing up in 50 HZ application. When the motor overheats, the thermo-protector cuts out, thus making the paper puller inoperative.

- QUICK FIX: Remove and save pulley cover, drip pan, and drip guard and cool motor down.
- PERMANENT FIX: Use new paper puller motor (246716-001); disregard VPN in IPB. Assemble the new motor with four spacers: (#8x3/8 OD x 1/4 LG), or equivalent, between frame and motor. This method allows air-circulation on the motor end-bell.

Failures of the plastic-toothed pulleys are due mainly to misalignment. Alignment of the two pulleys and tightness of the two set screws (with one of them on the flat of shaft) will minimize pulley failures.

Belt failures are due to wearout and misalignment of the pulleys.

At present, the spacer does not have a DEC (29-class) number. VPN is 800149-001.

NOTE: Additional changes to this subject will be communicated to the field via "GOODSTUFF".

COMPANY CONFIDENTIAL

LA38 SUPPORT ON TOPS-10 AND TOPS-20 OPERATING SYSTEMS

BY: ELBERT BLOOM
LCEG

I. CURRENT LA38 SUPPORT

1. Currently the LA38 is supported on TOPS-10 and TOPS-20 Operating Systems as an LA36 replacement. (i.e.: The operator, when applicable, must inform the monitor that his terminal is an LA36). The terminal will then be capable of performing the same functionality as an LA36 - with the following exceptions:

- a. The LA38 has no repeat key. Keys are auto-repeating instead.
- b. The keyboard layout is different.
- c. Different keys must be depressed on the LA38 in order to generate CTRL/@, CTRL/^, and CTRL/_ (See paragraph IV below).
- d. The LA38 does not have a 150 baud speed selection.
- e. The basic LA38 is a table model terminal. A stand is optional.

2. In addition, any of the ANSI (LA38) features may be used, either by manually selecting them, or via a customer applications program - if applicable.

A brief summary of these features follows:

- a. SUPPORT OF XON/XOFF
- b. SUPPORT OF STANDARD HORIZONTAL TABS.
- c. FOUR DIFFERENT HORIZONTAL PITCHES (FROM 132 TO 216 CHARACTERS PER LINE) - CAUTION: SEE PARAGRAPH IV BELOW.
- d. SIX DIFFERENT VERTICAL PITCHES (FROM 2 TO 12 LPI VERTICAL SPACING).
- e. VARIABLE MARGIN SETTINGS.
- f. TABLE OR PEDESTAL MODELS.

CONT. NEXT 2 PAGES →

II. FUTURE LA38 SUPPORT

"TOPS-20, Release 4" and "TOPS-10, Version 701" will be capable of recognizing an "LA38" command and, therefore, optimizing some of its terminal parameters accordingly. There will be no significant difference, as far as the user is concerned, over operation of the terminal as an LA36 replacement.

THE MOST LIKELY TERMINAL PARAMETERES TO BE OPTIMIZED BY THE MONITOR ARE AS FOLLOWS:

- a. ENABLE TABS FOR LA38 (Currently disabled for LA36)
- b. POSSIBLY ENABLE XON/XOFF FOR LA38 (XON/XOFF FOR LA36)

III. DEC SUPPORTED APPLICATIONS PROGRAMS

There are no current plans to upgrade any DEC supported applications programs. All DEC supported applications programs which currently operate on an LA36 will also operate on an LA38 (with no increased functionality).

IV. PRECAUTIONS

1. Different keys must be depressed on the LA38 in order to generate the following CONTROL CODES:

<u>OCTAL CODE</u>	<u>CHAR</u>	<u>GENERATED BY DEPRESSING</u>	
		<u>LA36</u>	<u>LA38</u>
000	NUL	CTRL/@	CTRL/(SP)
036	RS	CTRL/^	CTRL/
037	US	CTRL/_	CTRL/?

2. VARIABLE TABS - The variable tabs feature of the LA38 is not being supported by the TOPS-20 or TOPS-10 MONITOR or any supported Applications Programs.

It is also recommended that user applications programs not use the Variable Tabs feature. The LA38 TAB settings should be set to the standard positions.

3. TOPS-10 will currently support a maximum of 200 characters per line, TOPS-10, Version 701, however, will be capable of supporting 216 characters per line.

4. It is recommended that the following LA38 parameters always be set as indicated below (see the LA38 USER'S GUIDE for details):

PARITY	=	SPACE
XON/XOFF	=	ON
ANSI NEW LINE	=	OFF
AUTO LINE FEED	=	OFF
LOCAL ECHO	=	OFF

5. For detailed information concerning any of the issues in this memo refer to the "LA34/LA38 USER'S GUIDE".

V. LA38 OPTIONS WHICH CURRENTLY MAY BE SOLD FOR USE ON TOPS-10 AND TOPS-20 OPERATING SYSTEMS.

LA38-GA	BASIC LA38 (60 HZ OR 50 HZ)
LA38-HA	BASIC LA38 (AS ABOVE) PLUS STAND
LAX34-CL	20 ma INTERFACE OPTION

HOW TO FIX YOUR LIB + LB1 + LB2 FILES ON YOUR KLAD10 PACK!

BY: DAVID A. ROBERT
DIAGNOSTIC ENGINEERING - MARLBORO

To fix your LIB + LB1 + LB2 files on your KLAD10 Pack you have to edit your P1011.CMD file and add /BIN to all files that end with .LIB, .LB1, .LB2.

E.G.:	CXQLBN.LIB[6,10]/T011	} ADD THIS
	CXQLPF.LB1[6,10]/T011	
	CXQLPF.LB2[6,10]/T011	

Then you have to run KLAD10:

DO @P1011 AGAIN

NOTE: The LIB files get garbled without the /BIN switch.

ADD TO ALL KLAD10 PACKS PRIOR TO REVISION 12

COMPANY CONFIDENTIAL

UPDATE **** UPDATE **** UPDATE

LARS ?????

BY: JOHN SHEBELL
M.E.G.

An article on the above subject was published in GOODSTUFF #4. Since that time, three valid system types have been added. Below, please find an up-to-date list of valid system types.

* = ADDITIONS

- 1040 - single CPU KA based system.
- 1050 - single CPU KA based system w/swapper.
- 1055 - dual CPU KA based system.
- 1060 - single CPU KI based system.
- 1070 - single CPU KI based system w/swapper.
- 1077 - dual CPU KI based system.
- 1080 - single CPU KL based DecSystem 10 without internal channels.
- 1088 - dual CPU KL based DecSystem 10 without internal channels.
- 1090 - single CPU KL based DecSystem 10 with internal channels.
- * 1091 - single CPU KL based DecSystem 10 in corporate (i.e.: DecSystem 20) cabinets.
- 1099 - dual CPU KL based DecSystem 10 with internal channels (on either CPU).
- * 2020 - KS10 based system running either TOPS-10 or TOPS-20.
- 2040 - KL based DecSystem 20 without cache (core only).
- 2050 - KL based DecSystem 20 with cache (core only).
- * 2060 - single CPU DecSystem 20 with MF20 MOS memory or MOS/CORE mixed.

NOTE: There are no other valid entries for SYSTEM TYPE at this time.

TU45 TAKE-UP REEL TURNS HARDER
THAN NORMAL

(REF: PERTEC PIB #79072)
BY: GRAHAM MORLAND
LCG PS QUALITY ASSURANCE

Pertec shipped us an unknown quantity of T9000 (TU45) drives with a write ring installed on the take-up reel. Marlboro Manufacturing checked and purged their current units, however, some could have shipped to the field. Any drives shipped in the last quarter should be checked and the write enable ring removed from the tape-up reel if present.

SYMPTOMS ARE:

1. The take-up reel may be difficult to turn by hand when threading tape on to the take-up reel.
2. Under normal operation the take-up reel may not be as sensitive to tape loop position input as it normally should be.

CAUTION: FAILURE TO CHECK THESE DRIVES COULD RESULT IN THE FOLLOWING SITUATION.

TU45 TAKE-UP WRITE RINGS

BY: DANIEL W. WEISER
SANTA CLARA

This situation proved fatal to one of the demo machines used in the Western Region.

The write ring was jarred from the reel and was more or less captured between the reel and the drive's plastic faceplate. The ring in this location is thick enough to cause a slight braking action on the reel, (similar to a disc brake), but not noticeable to an Operator or Technician. It is, however, noticeable to the reel motor which subsequently overheats and this overheating causes the motor to pull more current through the drive transistors which then short and burn up the low .3 ohm wire wound resistor and an undetermined amount of other damage to the control board!

This specific case also burned up the power supply (literally), which also caused the supply reel's motor magnet polarity to be permanently reversed.

The short time it takes to remove this ring can save hours of troubleshooting and--

EXCEDRIN HEADACHE #45.

NOTE: This article has been submitted to CSS Nashua for Tech Tip publication.

HOW TO GET A REAL SNAP-SHOT OF A KL10 SYSTEM!

BY: MIKE FLYNN
 LCG PRODUCT SUPPORT

(VERSION III)

In the old days, when a computer system stopped doing its thing, there were lights to look at and buttons to push for the maintenance guy to try and see how bad the situation really was.

Today...no lights and no buttons (KL10)!

The following steps will allow you to examine a KL10-based system's processor, memory and sub-components in a relatively undisturbed state with these considerations:

1. Remember the device that you loaded KLDCP from, because that device and it's controller may be changed.
2. Pushing the load button on the KL, causes a unibus init. (Reset) and any device on the unibus may have been reset.

These steps should be used to gather accurate data on systems with intermittent problems.

ALL KL10'S

<u>TYPE TO KLDCP</u>	<u>WHERE</u>	<u>WHAT</u>	<u>CHANGES</u>
EE 174434	P. 1-29 D.T.E.M.	;DTE STATUS	
EE 174430 DE 174432/100 FX0	P. 1-30	;DTE DIAG 1. ;RESET DTE20 ONLY. ;TURN OFF CLOCK.	ADDED AT VER II BECAUSE OF INCORRECT FUNCTION READ INFORMATION.
ALL FRO FR100,177	P. 61-84	;LOOK AT ALL REGISTERS. ;LOOK AT EBUS. ;GET ALL FUNCTION READS.	ADDED AT VER III TO SEE IF EBUS HAS ANY STUCK BITS.
FX1,FX10,P	FX12,PC,FX12,PC,FX12,PC	;GET 4 EXTRA PC'S.	ADDED AT VER III TO GET LOOP PC'S FOR SOFTWARE PEOPLE.
ECO		;RESET MACHINE AND MICRO-CODE ADDRESS TO "0".	CHANGED FROM JUST RESET TO RESET AND START MICRO-CODE AT "0" AT VER II.
FX1		;TURN ON CLOCK.	
FX0		;TURN OFF CLOCK.	
EC		;LOOK AT MICRO-CODE ADDRESS. IS THIS THE HALT-LOOP FOR YOUR MICRO-CODE? ;NO, RUN DIAGNOSTICS. ;YES, CONTINUE.	

CONT. NEXT 2 PAGES →

COMPANY CONFIDENTIAL

<u>TYPE TO KLDCCP</u>	<u>WHERE</u>	<u>WHAT</u>	<u>CHANGES</u>
FX1		;TURN ON CLOCK, TO ALLOW INTERRUPTS WITH EXAMINES.	
EM16, 17		;CAN YOU EXAMINE? ;IF NO, RUN DIAGNOSTICS. ;IF YES, CONTINUE.	FORGOT ,17 AT VER II.
EX 700000 17, EM17	P. 34	;APRID., OPTIONS, VERSIONS, SERIALS.	
EX 701040 17, EM17	P. 37	;DATAI PAG., AC BLKS., SECTION, UBR.	
EX 701240 17, EM17	P. 37	;CONI PAG., ENABLES, EBR.	
EX 700400 17, EM17	P. 35	;RDERA., ERROR ADDRESS REGISTER.	
EX 720240 17, EM17	P. 1-26 D.T.E.M.	;CONI DTE #0., DTE STATUS.	
DM 16/100000 0		;SBUS DIAG. FOR DMA20 WORD0. ;ERROR ADDRESS REGISTER.	ADDED AT VER II FOR DMA20.
EX 700500 16, EM17		;SBUS DIAG. FOR MB20 #0.	
DM 16/0		;CONTENTS WORD0 CONTROLLER 0.	
EX 700500 16, EM17		;SBUS DIAG. FOR MB20 #0. ;CONTENTS WORD 1 CONTROLLER 0.	
DM 16/1		;SBUS DIAG. FOR MB20 #1. ;CONTENTS WORD 0 CONTROLLER 1.	
EX 700500 16, EM17		;SBUS DIAG. FOR MB20 #1. ;CONTENTS WORD 1 CONTROLLER 1.	
DM 16/20000 0		;SBUS DIAG. FOR MB20 #1. ;CONTENTS WORD 0 CONTROLLER 1.	
EX 700500 16, EM17		;SBUS DIAG. FOR MB20 #1. ;CONTENTS WORD 1 CONTROLLER 1.	
DM 16/20000 1		;SBUS DIAG. FOR MB20 #1. ;CONTENTS WORD 1 CONTROLLER 1.	
EX 700500 16, EM17		;SBUS DIAG. FOR MB20 #2. ;CONTENTS WORD 0 CONTROLLER #2.	ADDED AT VER III FOR INTERNAL MEMORIES.
DM 16/40000 0		;SBUS DIAG. FOR MB20 #2. ;CONTENTS WORD 1 CONTROLLER #2.	
EX 700500 16, EM17		;SBUS DIAG. FOR MB20 #2. ;CONTENTS WORD 1 CONTROLLER #2.	
DM 16/40000 1		;SBUS DIAG. FOR MB20 #2. ;CONTENTS WORD 1 CONTROLLER #2.	
EX 700500 16, EM17		;SBUS DIAG. FOR MB20 #3. ;CONTENTS WORD 0 CONTROLLER #3.	
DM 16/60000 0		;SBUS DIAG. FOR MB20 #3. ;CONTENTS WORD 0 CONTROLLER #3.	
EX 700500 16, EM17		;SBUS DIAG. FOR MB20 #3. ;CONTENTS WORD 0 CONTROLLER #3.	
DM 16/60000 1		;SBUS DIAG. FOR MB20 #3. ;CONTENTS WORD 1 CONTROLLER #3.	
EX 700500 16, EM17		;SBUS DIAG. FOR MB20 #3. ;CONTENTS WORD 1 CONTROLLER #3.	

COMPANY CONFIDENTIAL

<u>TYPE TO KLDGP</u>	<u>WHERE</u>	<u>WHAT</u>	<u>CHANGES</u>
EM ?500,?503	P. 22/23	; ? = UBR. ;?500 = PAGE FAIL WORD. ;?501 = PAGE FAIL PC+FLAGS. ;?502 = PAGE FAIL PC. ;?503 = PAGE FAIL NEW PC. ;UBR = 0 (500) ;UBR = 1 (1500) ;UBR = 2 (2500)	ADDED 502 AT VER II FOR PC. ADDED 503 AT VER III FOR KL10-PV PC.
AC BLK 7	P. 32&33	;MICRO-CODE AC BLOCK.	
EMO,2	P. 32&33	;ACO = AR DATA FOR PAGE FAIL. ;AC1 = ARX DATA FOR PAGE FAIL. ;AC2 = I/O PGF WORD.	
AC BLK 0		;SET AC BLOCK TO 0.	

Function read 110 with the page fail word (?500) plus the error address register (ERA), the DMA20 address register, and the page fail information should give you a good starting point.

FOR YOUR INFORMATION:

- D.T.E.M. = DTE MANUAL.
- PAGE NUMBERS WITH NO LETTERS ARE IN THE KL MAINTENANCE HANDBOOK.
- PAGE TABLE INFORMATION IS LOCATED ON PAGES:
22, 23, 24, 25, 26, 27, 32, 33, and 40.
- PAGES: 22 & 23 - GIVES PAGE TABLE BY LOCATION.
- PAGES: 24 & 25 - GIVES BREAKDOWN OF PAGE TABLE ENTREES FOR KL PAGING.
- PAGES: 26 & 27 - GIVES BREAKDOWN OF CHANNEL EPT AREA ENTREES.
- PAGE: 32 - GIVES BREAKDOWN OF "PC WORD".
- PAGE: 33 - GIVES BREAKDOWN OF PAGE FAIL WORD.
- PAGE: 40 - GIVES BREAKDOWN OF CHANNEL COMMAND WORDS.

NEW TERMINALS IN RELEASE 4

BY: SUMNER BLOUNT/JOHN SHEBELL
 LCG SOFTWARE ENGINEERING/M.E.G. - MARLBORO

Release 4 of TOPS-20 will support several new terminals which do not appear in the project plan. The new terminals to be supported are the LA120, VT100, and LA38. These changes will require the addition of three (3) new terminal types within TOPS-20.

The following table represents the major distinguishing characteristics of each terminal type. These are the attributes which will be set if the TERMINAL command is given. The last line in the table represents the actual symbol (and it's actual value) which defines the terminal type.

	<u>VT100</u>	<u>LA120</u>	<u>LA38</u>
Length	24	66	66
Width	80	132	132
Lower Case	Y	Y	Y
Padding	N	N	N
Tabs	Y	Y	Y
Form Feed	N	Y	N
Symbol	.TT100(20)	.TT120(21)	.TTL38(22)

COMPANY CONFIDENTIAL

CARDREADER PATCH PROCEDURE FOR RELEASE 3A 2020

BY: GREG ZIMA

SOFTWARE SERVICES MR1-2/S43

The distributed TOP-20 Release 3A 2020 Monitors were built incorrectly and as a result the cardreader does not work and will hang the job of someone trying to use it. Following is a procedure to produce a working TOPS-20 Release 3A 2020 Monitor with cardreader support. This procedure should be followed after the distributed Release 3A software has been installed, since only a new 3A monitor is to be created.

1. Use DUMPER to restore the files from the DISTRIBUTION TAPE saveset named "SOURCES FOR RELEASE 3A" to a working area to perform the monitor build. This is the fourth saveset on the tape.

2. Edit both the parameter files P2OSML.MAC and P2OMED.MAC to contain the following two lines after the line reading " CDRN==:1 ". BOTH of these lines are necessary.

```
FECDRN==:0          ;NO FRONT-END CARDREADER
KSCDRN==:1          ;KS CARDREADER
```

3. Submit the batch job to build the monitors. Refer to the BUILD.MEM document for more information. The following command is the one to use to build both the medium and small monitor.

```
$SUBMIT T2020/TIME:2:0:0/TAG:ALL
```

The monitors will be named 2020-MONSML.EXE and 2020-MONMED.EXE.

4. Patch and save the resulting monitors with DDT as follows:

```
$GET 2020-MONSML.EXE
$ST 140
DDT
CDRINT+12/   TRNE 1,100000   TRNE 1,110010
^Z
$SAVE 2020-MONSML.EXE
  2020-MONSML.EXE.2 SAVED
$!AND THE SAME FOR 2020-MONMED.EXE
```

5. Use these monitors in place of the ones provided on the released INSTALLATION TAPE in order to have a working cardreader.

NOTE The Cardreader used with the 2020 passes, but does not read the last card in the hopper. Therefore, an END-OF-FILE card should be followed by at least one card.

This article originally appeared in The Large Buffer - Volume 443
18-January-79.

ERRONEOUS SBUS DIAGS ON 1091'S

BY: KENNETH P. YOUNG
SOFTWARE SERVICES MR1-2/S43

1091 sites may have discovered their monitor reporting SBUS diags incorrectly (i.e.: zero). The reason for this is the 1091 may have up to four (4) memory interfaces, whereas; the other KL mainframes have only one (1).

TOPS-10 originally was designed to save only one SBUS diag for KL's with DMAs (in the CDB). With the 1091 LIR no provisions were made to store the possible four words contained in the SBUS diags.

No source patch will be available since no room is available for these words. With 7.01 these words will be stored in the CPU Status Block.

Until this problem is resolved, concerned installations may install the following patch which will capture all four (4) of the SBUS diags.

In KLSER at PRTRP+36 insert of PUSHJ P,PAT..

```
PAT../ SBDIAG CONT00          ;CONTROLLER 0 FUNCTION 0
        SBDIAG CONT01          ;CONTROLLER 0 FUNCTION 1
        SBDIAG CONT10          ;CONTROLLER 1 FUNCTION 0
        SBDIAG CONT11          ;CONTROLLER 1 FUNCTION 1
        SBDIAG CONT20          ;CONTROLLER 2 FUNCTION 0
        SBDIAG CONT21          ;CONTROLLER 2 FUNCTION 1
        SBDIAG CONT30          ;CONTROLLER 3 FUNCTION 0
        SBDIAG CONT31          ;CONTROLLER 3 FUNCTION 1
        POPJ      P,0          ;RETURN

CONT00: 0,,0
        0,,0
CONT01: 0,,1
        0,,0
CONT10: 20000,,0
        0,,0
CONT11: 20000,,1
        0,,0
CONT20: 40000,,0
        0,,0
CONT21: 40000,,1
        0,,0
CONT30: 60000,,0
        0,,0
CONT31: 60000,,1
        0,,0
```

NOTE: This article originally appeared in The Large Buffer - Volume 443, 18-Jan-79.

RSX-20F DOCUMENT

BY: KATHLEEN RICHER

MR1-2/E37

the RSX-20F System Specification is now available. This is an interim document that covers the following topics:

- The PDP-11
- RSX-11M
- Operating Systems
- Tasks
- FILES-11 System
- RSX-20F Requirements
- A comparison of RSX-20F and RSX-11M
- RSX-20F Internals
- RSX-20F Utilities
- Error Handling
- DTE Hardware Operation
- Front End Tasks
- RST10 and FE under TOPS-10
- RSX-20F Stop Codes

You can order this document from:

Digital Equipment Corporation
 Software Distribution Center
 146 Main Street - ML11-3/E52
 Maynard, Massachusetts 01754

NOTE: This article originally appeared in the Large Buffer - Volume 444, 25 January 79.

GOODSTUFF - INDEX

ISSUE 16 - MARCH '79
3RD QUARTER

- DFTUE B2 TEST VS. TOPS20 REL. 3 AND 3A
- 2020 COMM
- RSX-20F NAMING CONVENTION
- MAINDEC-10-DCXLA.INP VERSION 0.6
- COMPONENT FAILURES OF PAPER PULLER ASSEMBLY
- LA38 SUPPORT ON TOPS-10 AND TOPS-20 OPERATING SYSTEMS
- HOW TO FIX YOUR LIB+LB1+LB2 FILES ON YOUR KLAD10 PACK!
- LARS???
- TU45 TAKE-UP REEL TURNS HARDER THAN NORMAL
- TU45 TAKE-UP WRITE RINGS
- HOW TO GET A REAL SNAP-SHOT OF A KL10 SYSTEM! VER III
- NEW TERMINALS IN RELEASE 4
- CARDREADER PATCH PROCEDURE FOR RELEASE 3A 2020
- ERRONEOUS SBUS DIAGS ON 1091'S
- RSX-20F

GOOD STUFF

This document contains sensitive information which shall not be disclosed to personnel outside of Digital Equipment Corporation.

This Newsletter is meant as an information document. It's contents are not necessarily Company Policy. It's a means by which LCG Product Support can distribute some tidbits of information to you.

ISSUE NO. 17

* * *

APRIL-FY 79

STOP THAT BUG!

BY: BOB MALONEY

PRODUCT SUPPORT - MARLBORO

TOPS-20 monitor can be forced to halt on BUGHLT's, BUGCHK's, and BUGINF's.

Below you will find the tag's that relate to these conditions:

DBUGSW	0	DO NOT STOP ON BUGHLT'S
	1	STOP ON BUGHLT'S AND RELOAD (DEFAULT)
DCHKSW	0	DO NOT STOP ON BUGCHK'S (DEFAULT)
	1	STOP ON BUGCHK'S
DINFSW	0	DO NOT STOP ON BUGINF'S (DEFAULT)
	1	STOP ON BUGINF'S

603A AND DUAL-PORTED DISKS

BY: TED WOJCIK
M.E.G.

Shortly before the release of 603A it was discovered that running on-line diagnostics on a dual port drive was fatal to the system. According to Tony Wachs, TOPS-10 Software Engineering, the problem arises that the port not connected to the controller through which the diagnostic is being run sees the interrupts caused by running the other port of the drive. The way around this is to be sure that the other port of the device is detached from the system.

That is to say, if a drive were both RPA3 and RPB3 and you were running the diagnostic through RPB's controller you would also want to detach RPA3 to keep from KILLING THE SYSTEM.

Information about the detach command can be found in the Operators Guide on page 43.

EDITORArt O'Donnell
ASSOC. EDITOR...Nancie Mitchell
EDITORIAL OFFICEMR1-1/S35

GOODSTUFF is published on a
monthly-basis.

KL10 MAINTENANCE GUIDE
USE AND DURABILITY

BY: BOB SMITH
LCG COMM DEV. AND PUB.

By now, most of you have received your copy of the KL10 Maintenance Guide. I would like to make the following suggestions to improve the use and durability of these guides:

●Volume I contains the entire Hardware Section, the System Software Section, (RSX-20F, TOPS-10 and TOPS-20) and the Maintenance Software Section up to and including the 11-Based 11 Maintenance Library. Leave the original cover/copyright page in Volume II.

●Volume II should now contain the cover/copyright page, the 11-Based 10 Library, the 10-Based 10 Library, and the Notes Section.

NOTE: The cases designed to protect and store the guides were not available at the time of shipment. Therefore, Northboro will forward them to you as soon as they are available.

TOPS10 SYSERR CHANNEL ERROR LOGGING

BY: FRANK ROBBINS/TED WOJCIK
M.E.G. - MARLBORO

Channel errors seem to be the most ambiguous of errors to understand. It seems that proving whether the CHANNEL or the RH20 is the failing culprit become the most common issue. Therefore, it is necessary to gather all the CHANNEL/RH20 status and register information before attempting to determine the failure.

From a system standpoint, SYSERR is the tool used to gather the proper information about the failure. Options available at this time allow you to gather information from the MASSBUSS, CHANNEL, or BOTH. The first two mentioned options give data about one unit or the other (e.g.: CHANNEL or MASSBUSS). This information is useful, but having one without the other tends to give you only half of the information needed to fix the problem. Therefore, by using the switch/MASBTH will serve the best purpose in gathering information on the total channel status for any given failure.

The following sheets are sample printouts from a SYSERR report using the switch /MASBTH. First notice that the report is logged in two separate entries. To be sure the entries concern the same device, look at the DATE-TIME the error was logged for both the CHANNEL and RH20/DEV. Then be sure the device type is the same for both. If the above information concurs then you have a good idea that the two reports are about the same failure.

The information contained in the CHANNEL REPORT traces the channel command words starting with the JUMP command which points to the command list. The initial command word (JUMP) comes from the EPT loc $0+4*n$ where n =the channel number being accessed. The termination word will indicate the last block of words transferred even if an error occurred. One important thing to note about the termination word is the word count. If this count didn't go to zero or it is not a multiple of 128 words then there is a possibility the CHANNEL failed in some strange manner. However, before investigating the failure, be sure that multiple control words don't make up a total word count equal to 128. If this case exists, then skip type operations could be in effect.

The RH20/DEVICE report is necessary to examine the status word in the logout area. The status word supplies error information about the failure. NOTE: Before 7.00 the -APE bit is complemented by the software which results in the appearance of many address parity errors. Be careful when you think there is an address parity error as it may just be a quirk of the monitor. This is fixed in 7.00 and later monitors. The explanation of the error bits is in the KL-MAINTENANCE HANDBOOK on page 26. The CHANNEL status and logout information is found on pages 26, 27 and 40 of the handbook.

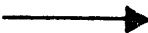
NOTE: SEE PRINTOUTS ON FOLLOWING PAGES 

SYSERR %13(1125) SYSTEM 1026. 23-FEB-79 11:28:40 PAGE 568

MASSBUS DISK ERROR

LOGGED ON 19-Feb-79 AT 17:51:10 MONITOR UPTIME WAS 3:06:07
 DETECTED ON SYSTEM # 1026.
 RECORD SEQUENCE NUMBER: 663.

UNIT ID: RPBI
 UNIT TYPE: RP06
 UNIT SERIAL #: 0002.
 MEDIA ID: DSKC1
 STR ID: DSKC1
 USER'S ID: 0,0
 LBN: 218501. =
 CYL: 575. SURF: 0. SECT: 1.
 OPERATION AT ERROR: DEV.AVAIL., GO + READ DATA (70)
 USER'S ID: 0,0
 USER'S PGM:
 USER'S FILE:
 ERROR: RECOVERABLE DRIVE EXCEPTION, CHN ERROR, IN CONTROLLER CONI
 DCK, IN DEVICE ERROR REGISTER
 REMAINING ENTRIES IN
 UNIT'S BAT BLOCK: 12.
 RETRY COUNT: 1.

CONTROLLER INFORMATION:

CONTROLLER: RH20 #540
 CONI AT ERROR: 0,222415 = DRIVE EXCEPTION, CHN ERROR,
 CONI AT END: 0,222415 = DRIVE EXCEPTION, CHN ERROR,
 CHN STATUS AT ERROR: 440100,0 = NOT WC = 0, LONG WC ERR,
 CHN STATUS AT END: 440100,0 = NOT WC = 0, LONG WC ERR,
 DATAI PTCR AT ERROR: 732601,177371
 DATAI PTCR AT END: 732601,177371
 DATAI PBAR AT ERROR: 720001,6421
 DATAI PBAR AT END: 720001,6421

DEVICE REGISTER INFORMATION:

	AT ERROR	AT END	DIFF.	TEXT
CR(00):	4070	4070	0	DEV.AVAIL., READ DATA (70)
SR(01):	50700	50700	0	ERR,MOL,DPR,DRY,VV,
ER(02):	100000	100000	0	DCK,
MR(03):	400	400	0	ZERO DET,
AS(04):	0	0	0	
DA(05):	2	2	0	D. TRK = 0, D.SECT = 2
DT(06):	24022	24022	0	
LA(07):	1220	1220	0	
SN(10):	2	2	0	
OF(11):	100000	100000	0	AT END:SIGN CHANGE, OFFSET=NONE
DC(12):	1077	1077	0	575.
CC(13):	1077	1077	0	575.
E2(14):	0	0	0	NO ERROR BITS DETECTED
E3(15):	0	0	0	NO ERROR BITS DETECTED
EP(16):	3422	3422	0	
PL(17):	2000	2000	0	

SYSERR %13(1125)

SYSTEM 1026. 23-FEB-79 11:28:40

PAGE 569

DATA CHANNEL ERROR

LOGGED ON 19-Feb-79 AT 17:51:11 MONITOR UPTIME WAS 3:06:08
 DETECTED ON SYSTEM # 1026.
 RECORD SEQUENCE NUMBER: 664.

DATA CHANNEL ERROR TOTALS

NXM'S AND OVERRUNS: 0.
 MEM PE SEEN BY CHANNEL: 0.
 CONTROLLER DATA PE
 OR CCW TERM CHK FAILS: 152.

CHANNEL COMMAND LIST BREAKDOWN

DEVICE USING CHANNEL: RPB1
 INITIAL CONTROL WORD: 200000,470
 TERMINATION WD WRITTEN: 402202,270670
 EXPECTED TERM. WORD: 600001,773476
 CHANNEL COMMAND LIST: 404002,270465
 402202,270670
 401601,773000
 3RD FROM LAST DATA WORD:731000,10
 2ND FROM LAST DATA WORD:0,0
 LAST DATA WORD XFERRED: 0,0

W A R N I N G

KL MODEL B CPU

If you have a Model B KL CPU, then running COBOL programs compiled by COBOL-74 can cause FM (fast memory) PARITY ERRORS, until you install Microcode revision 212. This is a timing problem in one case of the EXTEND EDIT op-code which occurs in some but not all Model B cpu's.

If this occurs, request that Field Service install Microcode revision 212 or later and discontinue running COBOL-74 and any programs compiled by it until the Microcode is fixed.

NOTE: This WARNING originally appeared in The Large Buffer - Volume 446, 8 Feb 79.

RP05/6 "LAMP MATRIX" PROBLEMS

BY: BOB BRISTER
 I.H.F.S. - MAYNARD

If you experience intermittent problems with heads unloading or other related drive sequence problems, a possible cause is the "Lamp Matrix".

A problem was discovered where a drive would drop off-line because the heads had unloaded. Diagnostics would also fail intermittently with heads unloading. It was found that by pressing the lamp test switch the heads would unload. The "Lamp Matrix" was found to be the culprit.

NOTE: A similar "Lamp Matrix" related problem was seen where, replacing the "Write Project" switch in the ON position, the drive would not spin up.

NOTE: This article has been submitted to Maynard for Tech Tip publication.

COMPANY CONFIDENTIAL

RSX20F AND KEEP-ALIVE-CEASED

BY: TED WOJCIK
M.E.G.

Keep-Alive-Ceased crashes are tough to get a handle on, so for 7.00 and Release 4, RSX20F will be modified to help make it easier.

The gist of the change is that RSX20F senses the KL has stopped (i.e.: the keep-alive count hasn't changed) then 20F will execute the instruction as 10 Location 71.

The Execute 71 is a technique to handle KEEP-ALIVE-CEASE errors in order to capture some information on the error before the system is reloaded. The flow is as follows:

1. With RETRY set via the PARSER (i.e.: SET RETRY) on a KEEP-ALIVE-CEASE error RSX-20F will perform a XCT 71, on the second error the Front End will act as if RETRY is clear. If RETRY is clear then on the error KLE will take a system snapshot and KLI will be requested to reload the KL. The default value of RETRY is set.
2. When RSX-20F does the XCT 71 it forces the KL10 to execute the instruction at location 71 (it is the responsibility of TOPS-10/TOPS-20 to guarantee a valid instruction at this location). If for some reason another KEEP-ALIVE-CEASE error occurs at the next time-out period after the XCT 71 then the Front End will take a snapshot and reload the KL.

The commands which enable/disable this mechanism are as follows:

COMMAND SUMMARY

SET RETRY	sets the flag and displays status
CLEAR RETRY	clears the flag and displays the status
WHAT RETRY	displays the status

To execute the SET/CLEAR RETRY commands, the console must be in PROGRAMMER or MAINTENANCE mode. The WHAT RETRY can be executed from any console setting.

I/O PAGE FAIL ERRORS AND COP STOPCODES IN 1090 SYSTEMS

BY: PAUL CLARK
IHFS

In September '78, I investigated the most likely causes of I/O Page Fail Errors and/or COP Stopcodes in 1090 style systems (See Goodstuff issue #14). Since that time, I have successfully used a logic analyzer to more easily determine, in multiple DTE-20 configurations, which DTE was being communication with at failure time.

In this article, I would like to detail the test points used and the waveforms which can be expected.

ANALYZER:

Product Support recommends that the Biomation Model #9100D be used for troubleshooting on KL10 based systems. This analyzer has 9 channels and a maximum sample rate equal to 10 NSEC between each sample.

The analyzer which was available to me was a Biomation Model #1650D which has 16 channels but only a maximum sample rate equal to 20 NSEC between each sample. This 20 NSEC sample rate was sufficiently fast and did yield very satisfactory results.

For the analysis detailed here, in order to provide a wider field of view, I would recommend that the 20 NSEC rate be selected regardless of which analyzer is used.

The analyzer was used in the pretrigger mode with the delay switches set to 640. This enabled the viewing of signal states before, during, and for a short period after error time.

The threshold selection switches were set to allow half the channels to monitor ECL switches and the other half to monitor TTL signals.

For purpose of trigger, the signal "APR SET I/O PF ERR L" was used. This requires that the APR module be extended because the signal does not come to the backplane.

CONT. NEXT 4 PAGES →

COMPANY CONFIDENTIAL

THEORY:

Because of the radial nature of the TTL EBUS signal "TRANSFER" in the I/O bay, it is possible to determine which DTE-20 is being communicated with, at error time, simply by monitoring the radial inputs to the M8559 module. See print set for M8559.

SIGNALS TO BE MONITORED:

1ST ECL CHAN	APR SET I/O PF ERR L	KL10PA-M8539	E37 PIN 15
		KL10PV-M8545	E30 PIN 15
2ND ECL CHAN	EBUS DEMAND E H	CPU BAY PIN	B31N1
3RD ECL CHAN	EBUS XFER E H	CPU BAY PIN	A31R1
1ST TTL CHAN	CNT31 EBUS XFER 08 L (DTE0)	I/O BAY PIN	D12E2
2ND TTL CHAN	CNT32 EBUS XFER 09 L (DTE1)	I/O BAY PIN	D12E1
3RD TTL CHAN	CNT33 EBUS XFER 10 L (DTE2)	I/O BAY PIN	D12D2
4TH TTL CHAN	CNT34 EBUS XFER 11 L (DTE3)	I/O BAY PIN	D12C1

NOTE: FOR "APR SET I/O PF ERR L" SEE PRINT APR1
TO ENSURE MODULE ETCHING CONFORMS.

NORMAL OPERATION:

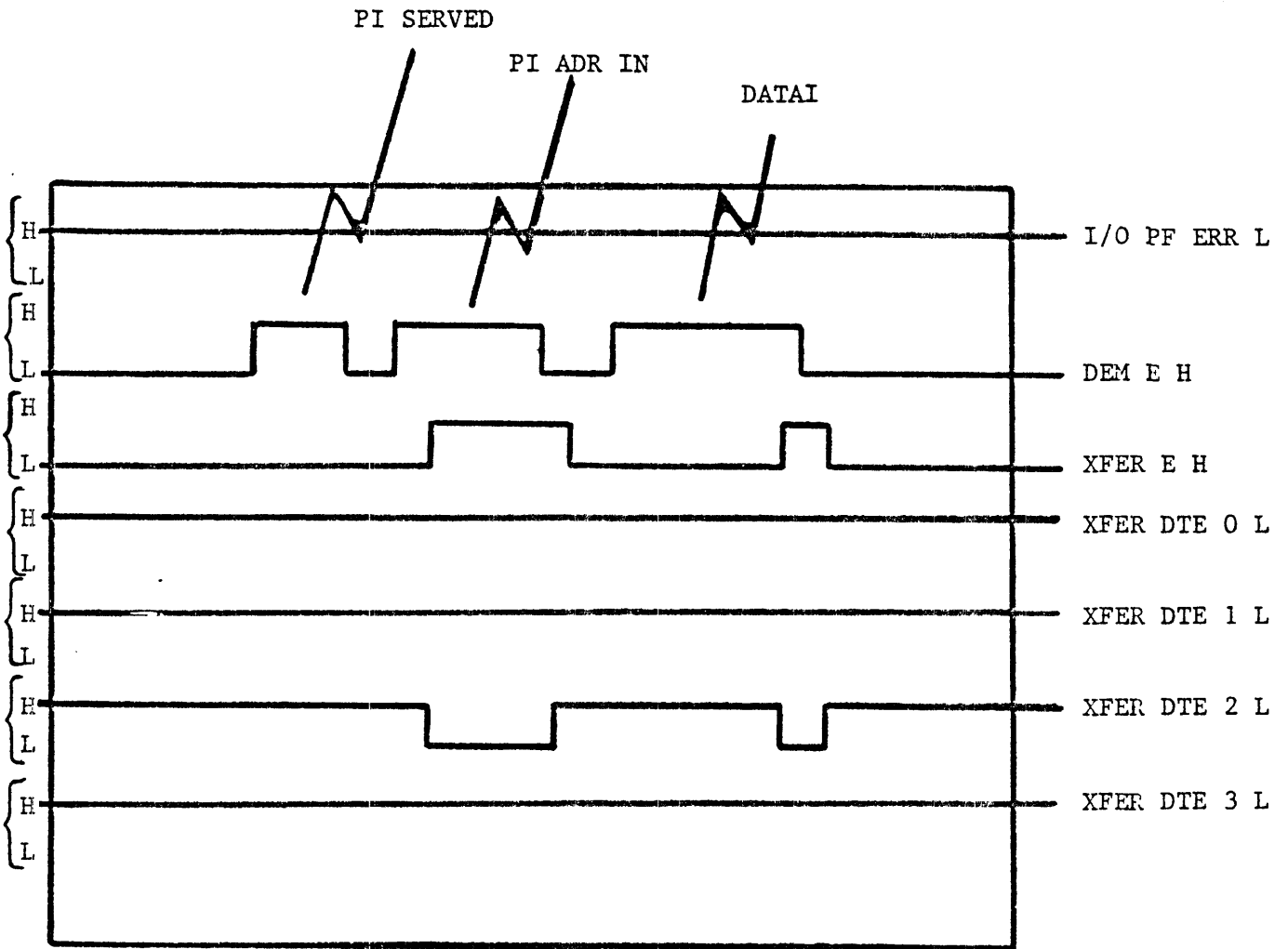

NORMAL OPERATION FOR DTE # 2

To view normal operation sync positive on 1st, 2nd, 3rd, or 4th TTL signal only and observe the display. Also, set the delay switch to 240.

ERROR TIME:

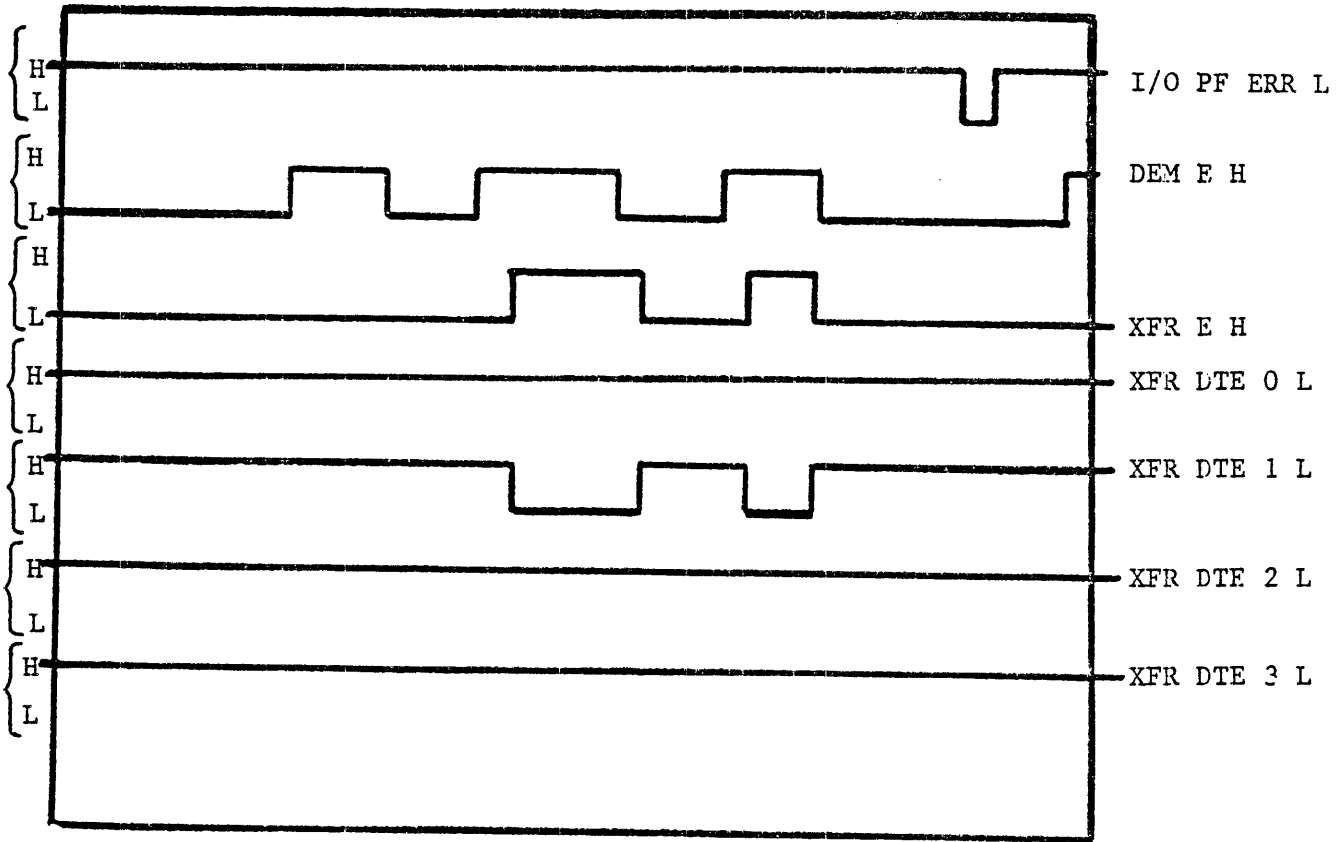

I/O PAGE FAIL CAUSED BY DTE #1

ATTENTION:

BEFORE ERROR TIME:

Set the delay switches to 640.

Sync on 1st ECL chan only ("APR SET I/O PF ERR L").

NOISE:

It is important to discern between false triggering and real errors. The analyzer is sensitive to noise from the environment, so if the display is not as shown above, it is most probably not a valid piece of information. It is a good idea to cordon off the area in front of the machine to avoid triggering by "charged" people passing by.

ERROR DISPLAY ANALYSIS:

In multiple DTE-20 Systems, it is important that at least three valid error displays be recorded to ensure that the DTE being communicated with is always the same one. This analysis can be made by observing the states of radial "transfer" signals. Only one DTE-20 should be asserting the signal during any given communication set.

If the errors are occurring during communication with all the DTE's in the system, then the problem is more complex and most probably related to the EBUS itself, it's translators, or pollution of the bus by some other module which interfaces to the EBUS, such as; an M8555 in an RH20.

If the errors always occur during communication with the same DTE-20 the M8552 in that DTE is most probably marginal.

NOTE:

The procedure outlined in this article can also be used on KL-based DECsystem 20's. If a 2050 system bughalts with an "IOPGF" the page fail word is available in AC5 of the dump or SYSERR entry besides AC Block 7 Location 2.

```
$
$
$
$
$FILDDT
FILDDT>LOAD (SYMBOLS FROM) <SYSTEM>MONITR.EXE.20
FILDDT GET (FILE) DOLFIN: <SYSTEM> DUMP.IOPGF.1
[AC'S COPIED FROM BUGACS TO 0-17]
```

[FILE: DOLFIN: <SYSTEM>DUMP.IOPGF.1 LOADED]

```
BUGP1/      IOPGF+2
5[          363001,,44660
↑Z
EXIT
$
```

NOTE: Cross-reference - KL10-TT-68.

COMPANY CONFIDENTIAL

TECHNICAL ASSISTANCE CENTER

BY: BETTY HOPPER
LCG PRODUCT SUPPORT-MARLBORO

The Technical Assistance Center has now moved into its new quarters!!!

We are sure that our expanded work area will allow us to be even more efficient at achieving our goals...to prevent possible problems where feasible, and to solve other problems that cannot be handled by District or Regional Offices.

We are working on a feedback system (to the Regions) which will help us share our experiences in investigative results.

Our new quarters contain two (with a possible third) KLINIK stations for remote diagnosis, a complete technical library, an action/outage board, field "locator" map and, most importantly, PEOPLE. Our Corporate Engineers are thoroughly trained veterans of many years' experience.

The recent addition of an after-hours telephone message unit will enhance our ability to respond as quickly as possible to a much wider field base. These messages are retrieved first thing in the morning and at intervals on weekends. When using this system, please remember to leave your name, telephone number where you can be reached, time of the call, and a short description of the problem.

We get two basic types of calls at the T.A.C., regular assistance/information calls (which are recorded in our TAC Log) and Central Log Desk calls. The CLD calls indicate a possible need for on-site help and should be placed no later than T24 to give us enough response time. All calls will normally be answered either immediately or within an hour.

When not actively involved in on-site help, our Engineers are answering T.A.C. calls, investigating problem reports, filing trip reports, going through training courses on recent options, and special projects (new products). They interface with Diagnostic Engineering, Hardware Engineering, Software Engineering, various Product Lines, Manufacturing and anywhere else they have to go to get the job done.

What you, the Field, have in the T.A.C is a highly-motivated, highly-skilled, central source of knowledge and expertise. To draw from this source takes but a telephone call!

LARGE COMPUTER GROUP Technical Assistance Center DIGITAL EQUIPMENT CORPORATION 200 FOREST STREET MARLBORO, MASSACHUSETTS 01752 (617)481-9511, ext. 6903 or 6904
--

MF20 MAINTENANCE NOTES

BY: JOHN SHEBELL
M.E.G.

The inclusion of two major fault tolerant features, single bit error correction and dynamic spare bit substitution, within the MF20 architecture significantly improves the potential reliability of the product. At the same time these features create some potential for confusion since logic "failures" no longer directly translate into system "failure". Simply put, it becomes necessary to define how many tolerated failures can be allowed before the MF20 is defined to be "broken". The purpose of this article is to describe the fault tolerant features included in the MF20 and outline recommendations for determining when remedial service is required as a result of accumulated tolerated failures.

BACKGROUND

The MF20 includes two features targeted towards improving the reliability of the product. The first is an implementation of single bit error correction, double bit error detection coding similar to that used in many other large MOS memories. This feature ensures that the system "sees" correct data even though some number (perhaps all) words in memory have one defective bit. Any word that has two bits in error cannot be "tolerated" and generates an error equivalent to a parity error on our more traditional core memories. Since the most prevalent failure mode of the memory "chips" is a random single bit failure, the primary maintenance concern is assuring that the probability of getting a double bit error is very low. Double bit errors tend to occur when there are many existing single bit errors in memory. Thus, minimizing the total number of single bit errors also minimizes the probability of double bit errors. Perfection in this regard is not necessary and would be very expensive. What must be avoided is a significant collection of single bit faults. The quantification of "significant" will be addressed later.

The second feature, dynamic spare bit substitution, is quite unique in the industry. The exact implementation is too complex to describe here. For most purposes, however, this feature can be envisioned as a set of "spare" bits which can be switched in under software control to replace defective bits throughout the memory space. The restrictions inherent in the design preclude handling all possible cases, but the design can handle almost all cases when the number of single bit errors is "small" in relation to the overall capacity of the memory. As with the single bit error correcting code, the service concern is keeping the aggregate number of single bit errors below some "significant" level.

CONT. NEXT PAGE →

COMPANY CONFIDENTIAL

POLICY:

The net result of the considerations outlined above is that the fault tolerant features are most effective (i.e.: MTBF is maximized) if the total number of single bit faults is kept below some value. The only difficulty is in setting a reasonable value.

Both our experience during Design Maturity testing and numerical modeling was used to determine a level of single bit failures which maximizes reliability without incurring prohibitive spares costs. This analysis indicated that the aggregate number of single bit faults which could be "tolerated" without any remedial service action was on the order of 1% per 256 K of memory. This value translates into the following specific maintenance policies:

1. Any occurrence of double bit errors is to be treated as a parity error would be on core memories. That is, immediate remedial service should be performed consistent with established procedures and the customer's contract obligations.
2. During scheduled MF20 Preventative Maintenance periods, diagnostic programs (and TGHA output) should be reviewed to determine if any of the following conditions exist in and 256K segment of MF20 memory:
 - a. Any MOS chip is totally defective (i.e.: 16K defective bits.
 - b. Any MUX chip is defective.
 - c. The aggregate number of solid single bit locations per 256K segment exceeds 2,560 (i.e.: 1% of capacity).

MOS array module(s) should be replaced until the above conditions no longer exist. Naturally, the most defective should be replaced first. Note that it is not necessary to purge all single bit failures, but merely to get below 0.5% of capacity. TGHA should be used for this analysis. The MF20 diagnostic can also be used, but requires careful analysis.

It should be noted that no consideration is made at this time for the spare bit substitution facility. As experience with TGHA is gained, this policy will be updated to reflect any changes. Note that TGHA is not required for the memory system to function reliably, it does, however, allow PM periods to be scheduled less frequently.

RH20 MASSBUS CONNECTORS (KL10)

BY: JOE BLANCO/PAUL CLARK

I.H.F.S. - DISTRICT SUPPORT, MAYNARD

A problem has been found in the RH20 Massbuss Connectors in the KL10. The six screws on the male side of the connector must be fully tightened. If they are not tightened down properly, the female pins of the connector will not be flush with the connector block, causing improper pin connection. The six screwheads can be seen from the pin side of the RH20 backplane.

Cross-reference: RH20-TT-4.

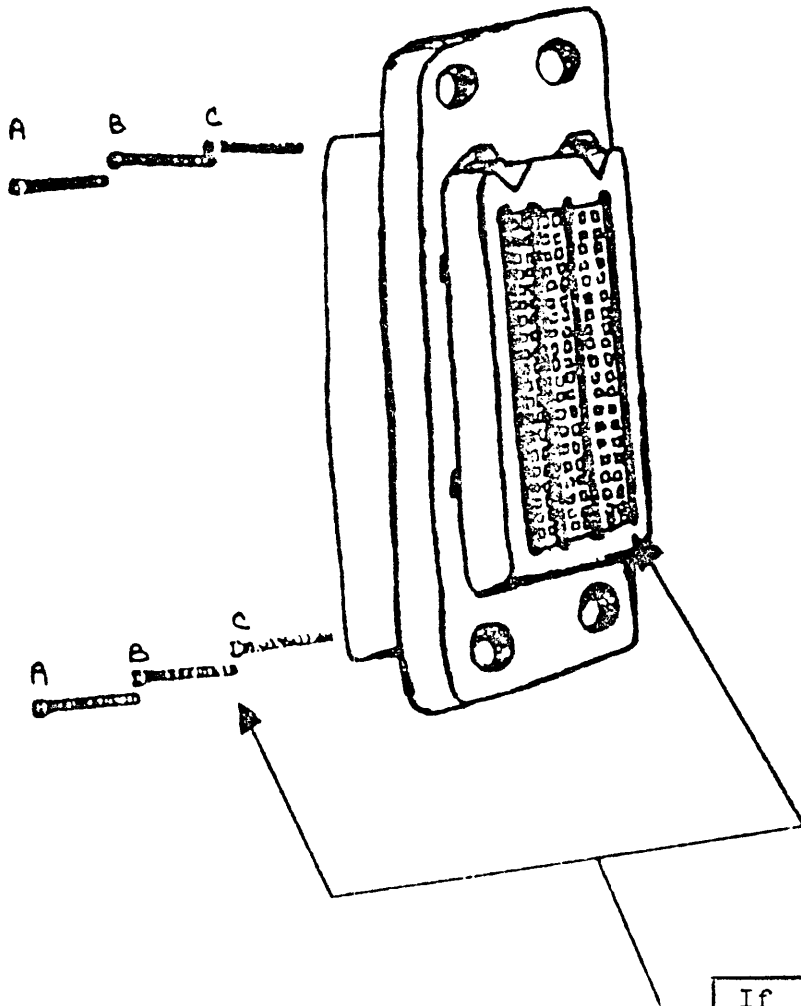

COMPANY CONFIDENTIAL

SAVING ERROR.SYS ON TAPE

BY: TED WOJCIK
M.E.G.

I have often been asked about the best way to save ERROR.SYS files on a history tape that can be used directly with SYSERR. After checking and trying several methods, it appears I have one which will work! The procedure comes in two parts, one to be used the first time the tape is used, and, one to be used thereafter. The procedures assume you have renamed ERROR.SYS to be ERROR.LWK. (This avoids duplicate records on tape.)

The first procedure is as follows. You need not duplicate the logical names, mount commands, or the density commands.

```
MOUNT MTB:TAPE/REELID:RETRO/WE
SET BLOCKSIZE TAPE:128
SET DENSITY TAPE:1600
REWIND TAPE:
R PIP
TAPE:/B=SYS:ERROR.LWK/B
```

```
REWIND TAPE:
DISMOUNT TAPE:/REMOVE
```

After the tape has the first records on it, the following procedure is used to append new records:

```
MOUNT MTB:TAPE/REELID:RETRO/WE
SET BLOCKSIZE TAPE:128
SET DENSITY TAPE:1600
REWIND TAPE:
SKIP TAPE:EOT
BACKSPACE TAPE:1 RECORD
SKIP TAPE:1 RECORD
R PIP
TAPE:/B=SYS:ERROR.LWK/B
```

```
REWIND TAPE:
DISMOUNT TAPE:/REMOVE
```

The tapes created by this method may be used directly with SYSERR using the tape as the logical input device. A sample command follows:

```
R SYSERR
*DSK: ALLSUM.LST=TAPE:/ALLSUM
```

COMPANY CONFIDENTIAL

THANKS FOR YOUR HELP!!!
BY: JEFF GARDINER
PRODUCT SUPPORT - MARLBORO

I would like to express my thanks for the response to my article asking for suggestions on KL Maintainability.

The following people sent many interesting and creative ideas and suggestions to me:

ED BERNA.....MERRIMACK, NH
JOHN BERNARD.....WALTHAM, MA
DICK BRÖWN.....MARLBORO, MA
WILLY BRUNEAU.....MAYNARD, MA
BILL CLEVENGER.....PEORIA, IL
F. FOX.....SEATTLE, WA
MARK HASTINGS.....DAYTON, OHIO
HENRY HICE.....TUCSON, AZ
JOHN KRZYSZTOW.....SOMERSET, NJ
L.S. MANCHESTER.....DETROIT, MI
DAVE MILOSEVICH.....PHOENIX, AZ
GEORGE MLADSI.....MAYNARD, MA
BOB NOBREGA.....MAYNARD, MA
NOEL PEASE.....PHOENIX, AZ
JIM RONEY.....CINCINNATI, OH
DAVE RUSSELL.....MARLBORO, MA
AL SCHATZEL.....MAYNARD, MA
CHARLIE SMITH.....WALTHAM, MA
MIKE STARKEY.....PHOENIX, AZ
DAN WATT.....CLEVELAND, OH

All inputs are included in my report and are valuable to understanding what areas of the KL effect the Field Engineers most.

Keep your "thinking caps" on and keep those cards and letters coming in.

Thanks again.

COMPANY CONFIDENTIAL

THE TRUTH ABOUT KLERR

BY: TED WOJCIK
M.E.G.

Many rumors have seeped back here to Marlboro that KLERR reports from SYSERR are in error. The purpose of this article is to set down what versions-of-what play together correctly.

Under TOPS-20 the combination which was tested and is known to work is TOPS-20 Release 3A with SYSERR Version 12 (763). This combination has been tested for Cram Parity Errors and should be correct for all cases involving clock stops. Further work is planned to check results for DEX errors and KEEP-ALIVE-CEASED errors.

Under TOPS-10 there is currently no known working version in the field. A patch has been developed which can be applied to SYSERR Version 12A (1015) which corrects the handling of KLERR reports. Version 12A was first shipped with the 603A monitor release. This fix will be in SYSERR Version 13 which will ship with TOPS-10 Version 7.00.

This fix has been tested with CRAM Parity Errors and halts, and should be correct for all cases involving clock stops. Further work is planned to check results for DEX errors and KEEP-ALIVE-CEASED errors. Only believe a KLERR Report produced by a "fixed" version of SYSERR.

There are two ways of installing this fix in the field--in the source code which will require re-assembly and linking or in the .EXE file directly using FILDDT. I am including both the changed source code and the FILDDT output so that you can make the choice of method.

First, if you are patching the EXE file, use FILDDT on SYSERC.EXE and the following are the comparisons of what is there, to what should be there, beginning at location KL201A.

CONT. NEXT 1½ PAGES →

COMPANY CONFIDENTIAL

IS

SHOULD BE

KL201A/ LDB 1,MASDSP#+645	KL201A/LDB 1,MASDSP#+645
KL201A#+1/ MOVEM 1,0(6)	KL201A#+1/MOVEM 1,0(6)
KL201A#+2/ AOS 7	KL201A#+2/AOBN 6,KL201A#+4
KL201A#+3/ CAMN 7,PAKSIZ	KL201A#+3/PUSHJ 17,KLEDON#
KL201A#+4/ PJRST PAKDON	KL201A#+4/AOS 7
KL201A#+5/ AOBN 6,KL201A#+7	KL201A#+5/CAMN 7,PAKSIZ
KL201A#+6/ PUSHJ 17,KLEDON#	KL201A#+6/PJRST PAKDON#
KL201A#+7/ LDB 1,MASDSP#+653	KL201A#+7/LDB 1,MASDSP#+653
KL201A#+10/ MOVEM 1,0(6)	KL201A#+10/MOVEM 1,0(6)
KL201A#+11/ AOS 7	KL201A#+11/AOBN 6,KL201A#+13
KL201A#+12/ CAMN 7,PAKSIZ	KL201A#+12/PUSHJ 17,KLEDON#
KL201A#+13/ PJRST PAKDON	KL201A#+13/AOS 7
KL201A#+14/ AOBN 6,KL201A#+16	KL201A#+14/CAMN 7,PAKSIZ
KL201A#+15/ PUSHJ 17,KLEDON#	KL201A#+15/PJRST PAKDON#
KL201A#+16/ AOBN 5,KL201A#	KL201A#+16/AOBN 5,KL201A#

Alternately, for all you Teco freaks, you can change the sources to reflect the fix in SYSERC.MAC at KL201A: Then rebuild SYSERR using the supplied batch job CTL file.

CHANGE FROM

```

KL201A: LDB      T1,[POINT 16,0(P1),15] ;GET LEFT BYTE
        MOVEM    T1,0(P2)                ;PUT IT AWAY
        AOS      P3
        CAMN     P3,PAKSIZ
        JRST     PAKDON
        AOBN     P2,..+2                  ;UPDATE STORE POINTER
        PUSHJ    P,KLEDON                 ;FILE IS FINISHED
        LDB      T1,[POINT 16,0(P1),31] ;GET RIGHT BYTE
        MOVEM    T1,0(P2)                ;AWAY
        AOS      P3
        CAMN     P3,PAKSIZ
        JRST     PAKDON
        AOBN     P2,..+2                  ;UPDATE STORE POINTER
        PUSHJ    P,KLEDON                 ;FILE IS FINISHED
        AOBN     P1,KL201A                ;GET NEXT PAIR
    
```

TO

```

KL201A:  LDB      T1,[POINT 16,0(P1),15]  ;GET LEFT BYTE
         MOVEM   T1,0(P2)                  ;PUT IT AWAY
         AOBJN   P2,+.2                    ;[1127]UPDATE STORE POINTER
         PUSHJ  P,KLEDON                   ;FILE IS FINISHED
         AOS     P3
         CAMN   P3,PAKSIZ
         JRST   PAKDON
         LDB      T1,[POINT 16,0(P1),31]  ;GET RIGHT BYTE
         MOVEM   T1,0(P2)                  ;AWAY
         AOBJN   P2,+.2                    ;[1127]UPDATE STORE POINTER
         PUSHJ  P,KLEDON                   ;FILE IS FINISHED
         AOS     P3
         CAMN   P3,PAKSIZ
         JRST   PAKDON
         AOBJN   P1,KL201A                ;GET NEXT PAIR
    
```

This is edit number 1127. If you have any doubts as to whether you can successfully install this patch, you can call the DDC and request that they do it for you over the KLINIK line in User Mode or over a normal timesharing line. Alternatively, you can ask your customer to do it for you. In either case, you will be able to use the KLERR reports in isolating CPU faults.

RP06 ABSOLUTE FILTER CHECK

BY: JOSE BLANCO
I.H.F.S. - MAYNARD

The availability of the absolute filter has been a problem in the past and may continue in the future. Rather than just replacing, they should be checked to determine if replacement is necessary.

Included in the scheduled maintenance procedure is a pressure check on the Air-filtering System of the RP06. The proper fittings for this procedure have been difficult and expensive to acquire.

The problem can be resolved by purchasing a Tru-flate chuck (#17-351) and fitting (#1581).

NOTE: These fittings can be purchased at any Auto Supply Store at a total price of not over \$2.00.

With these fittings and pressure gage (DEC part #29-22191) your reading should be less than 1.25 inches of V.A.C., if not--replace the absolute filter.

KS10 UNIBUS TERMINATION

BY: ROBERT NOBREGA
I.H.F.S.

If you are having problems with what appears to be a hung UBA on your KS10, you may not have the sack turn-around enabled on the M9300 unibus terminator.

To enable this logic you should cut the jumpers on the M9300 unibus terminator as follows:

W1=IN ; W2=OUT ; W3=OUT .

Cross Reference: KS10-TT-1

DID YOU KNOW THAT THE FOLLOWING ISSUES OF GOODSTUFF ARE DOCUMENTED ON MICROFICHE:

- January - Issue #14:
appears on Speed Bulletin #67,
1-11-79.
- February - Issue #15:
appears on Speed Bulletin #72,
2-26-79.

GOODSTUFF - INDEX

ISSUE 17 - APRIL '79
3rd QUARTER

- STOP THAT BUG!
- 603A AND DUAL-PORTED DISKS
- KL10 MAINTENANCE GUIDE - USE AND DURABILITY
- TOPS10 SYSERRR CHANNEL ERROR LOGGING
- WARNING - KL MODEL B CPU
- RP05/6 "LAMP MATRIX" PROBLEMS
- RSX20F AND KEEP-ALIVE-CEASED
- I/O PAGE FAIL ERRORS AND COP STOPCODES IN 1090 SYSTEMS
- TECHNICAL ASSISTANCE CENTER
- MF20 MAINTENANCE NOTES
- RH20 MASSBUS CONNECTORS (KL10)
- SAVING ERROR.SYS ON TAPE
- THANKS FOR YOUR HELP!
- THE TRUTH ABOUT KLERR
- RP06 ABSOLUTE FILTER CHECK
- KS10 UNIBUS TERMINATION

(CLIP & MAIL)

WANT TO RECEIVE GOODSTUFF...

Simply fill out this card and drop it in the nearest interoffice mailbox.

(PLEASE PRINT)

NAME: _____

U.S. BADGE #: _____

FS COST CENTER: (700's only) _____

LOCATION CODE/ADDRESS: _____

Do you wish to have back copies?

YES NO

NOTE: It takes approximately one-month to appear on the distribution once this registration card is received.

Any questions please contact Nancie Mitchell -MR1-1/S35 - TWX Code: MR11

RETURN TO:

NANCIE MITCHELL

MR1-1/S35

GOOD STUFF

This document contains sensitive information which shall not be disclosed to personnel outside of Digital Equipment Corporation.

This Newsletter is meant as an information document. It's contents are not necessarily Company Policy. It's a means by which LCG Product Support can distribute some tidbits of information to you.

ISSUE NO. 18

MAY FY 79

HOW TO ORDER THE KL10
MAINTENANCE GUIDE

BY: LOU NAY

PRODUCT SUPPORT - MARLBORO

When ordering the KL10 Maintenance Guide (EK-OKL10-MG), you must specify the following:

- Name of person to receive the guide.
- That individual's badge number, cost center, and location code.

The number of copies is limited to one copy per person and further limited to the following cost centers:

- ALL 700 series Cost Centers.
- ALL 800 series Cost Centers.
- All 35* cost centers. (* = any alpha character)
- Cost Centers 3FA and 67C.

The reasons for the stringent criteria of ordering these guides are because this two-volume set was made updatable so that periodic updates, currently bi-monthly, could be handily incorporated. In view of the additional costs of doing it this way, we needed to insure that the publication got to where it was needed as quickly and accurately as possible. Thus, the subscription method.

NOTE: This subscription list will be maintained in Northboro and will be matched against the corporate data bases, so that updates will follow you when you transfer or change locations.

DIAGNOSTIC PROBLEMS

BY: TOM RITTER
DISTRIBUTED SYSTEMS SUPPORT

It has recently come to our attention that problems exist with the following diagnostic:

DUP11 CZDPC-CO

The CZDPC-C problem is a failure in test 5 which only occurs with CS Revision J or later M7867 modules. This problem has been corrected in a new revision of this diagnostic which has been submitted to SDC and should be available by the end of May '79. In the meantime, the following patch may be used:

Change: 11406 to 137
11407 to 11446

This patch jumps around a test which tested REOM and expected it to be clear. M7867-FCO-S005 which made the CS Revision J, changed the receive buffer to clear on INIT or device reset instead of the loss of framing.

EDITORArt O'Donnell
ASSOC. EDITOR...Nancie Mitchell
EDITORIAL OFFICEMR1-1/S35

GOODSTUFF is published on a monthly-basis.

ALERT****ALERT****ALERT

BY: GENE YONCHAK/BILL FISCHER
M.E.G./LCG PRODUCT SUPPORT

A WARNING WAS PUBLISHED IN GOODSTUFF #17 - APRIL REGARDING: KL MODEL B CPU. THIS ARTICLE CONTAINED INACCURATE INFORMATION WHICH WE WILL EXPLAIN BELOW:

PLEASE NOTE THE FOLLOWING:

FIELD SERVICE DOES NOT INSTALL SOFTWARE! WE DO NOT HAVE THE RESOURCES AND IN SOME CASES, THE NECESSARY EXPERTISE.

IN CONCLUSION:

●MICRO-CODE VERSIONS ON CUSTOMER PACKS ARE THE RESPONSIBILITY OF THE CUSTOMER. HE SHOULD ORDER THE APPROPRIATE MICRO-CODE VERSION FROM SDC.

●EITHER THE CUSTOMER, OR HIS SOFTWARE REPRESENTATIVE ARE RESPONSIBLE FOR INSTALLING NEW MICRO-CODE VERSIONS.

AGAIN, SORRY FOR THE ERROR—HOPE IT HASN'T CAUSED TOO MUCH CONFUSION.

QUALITY OF FIELD SERVICE SPARES - OVERVIEW

BY: JOE MC DERMOTT
F.S. SPARES QUALITY - MAYNARD

My intent is to put the overall quality of Field Service spares into proper perspective. The general feedback shows that some of the specific failure rates become applied across the board to include all spares, which has tended to muddy the water and create or propagate a very negative (and erroneous) undertone. And that undertone has been creeping into conversations with the Field Engineers and on to our Customers.

The Quarterly Quality of Spares Report, which we produce, is intended to focus on those parts which need priority attention and corrective action. It is these parts which the field sees most frequently (in sheer numbers and impact) as DOA's. Perhaps our report contributes to the impression that all spares suffer the same fate. This is not the case.

THE QUALITY OF SPARES IS GOOD

Field Service uses more than 2.4 million parts (16,200 different part numbers) to perform maintenance and repairs in a year. 98.7% of the time the part used works as intended and the Field Engineer accomplishes the repair activity with good spare parts. This is a quality level that we can all be proud of and can express with confidence. Digital does a lot of things right and this is one of them.

THE QUALITY OF SPARES IS BEING IMPROVED

However, there are 1256 part numbers which have not consistently achieved the 96% quality level (our present goal for all spares) as individual performers. Our focussed efforts are being applied to these parts to correct the specific causes and bring each of them within the good quality range. But in the meantime, the TRUE Quality of Spares must be kept in perspective. And it must be communicated correctly to our Field personnel as well as Digital's Customers.

Please ask questions when general numbers are thrown around. Please report the real problems. And please make a concerted effort to communicate the good Quality of Spares.

COMPANY CONFIDENTIAL

PITRAP BUGHLTs AND AR/ARX PARITY
PROBLEMS IN TOPS-20
BY: ROY G. DAVIS
TUCSON

When a page failure occurs on a DECSYSTEM-20, the systems traps through location 503 of the user process table to the code at PGRTRP to handle the page failure. At PGRTE1, a test is made to see if any interrupts are up. If so, the monitor goes to PIPTRP wherein an attempt is made to separate PITRAPs from possible AR/ARX parity errors. Unfortunately, the monitor tests the contents of location TRAPSW (location 301 of the UPT) when in fact it should test the contents of TRAPSO (location 500 of the UPT).

The patch to correct this for both release 3 and 3A is as follows:

```
$GET PS:<SYSTEM>MONITOR.EXE
$START 140
DDT
PIPTRP+1/ MOVE T1,TRAPSW  MOVE T1,TRAPSO
^Z
$SAVE PS:<SYSTEM>MONITOR.EXE
```

Just a couple of things to note:

Eventually, the contents of TRAPSO will get moved to TRAPSW, but not before the test on the P1 system occurs at PGRTE1. Also, both TRAPSO and UPTPFW are location 500 of the UPT.

KL10 ERROR REGISTERS
BY: MIKE FLYNN
LCG PRODUCT SUPPORT- MARLBORO

The following charts will enable you to decipher KL10 errors. Start with Chart A, Go to Chart B, then to C & D.

NOTE: See following four pages.....

The KL10's arithmetic processor register (APR) latches (hardware or software) error conditions. The following bit chart reflects conditions which can easily be described. Other conditions will require a considerable amount of concentration and study to determine why they occurred.

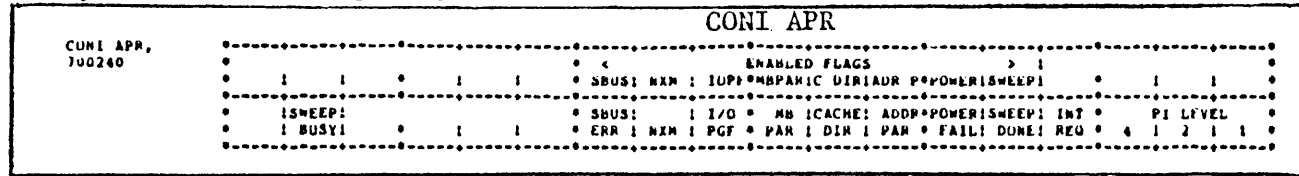

CHART A (APR):

BIT	24	25	26	27	28	29	
NAME	SBUS ERR	NXM	I/O PGF	MB PAR ERROR	CACHE DIR	ADDR PAR ERR	
	0	0	0	0	1	0	CACHE DIRECTORY PARITY ERROR. PROBABLE CAUSE: M8514/M8515
	0	0	0	1	0	0	MEMORY BUFFER PARITY ERROR. PROBABLE CAUSE: SEE CHART B:
	0	0	1	1	0	0	MEMORY BUFFER PARITY ERROR DURING AN INTERRUPT. PROBABLE CAUSE: SEE CHART B:
	0	1	0	1	0	0	NON-EXISTENT MEMORY ADDRESS. PROBABLE CAUSE: SOFTWARE THOUGHT THERE WOULD BE MEMORY AT THIS ADDRESS OR THE MEMORY SYSTEM DID NOT ACKNOWLEDGE. SEE CHART B:
	0	1	0	1	0	1	SBUS ADDRESS PARITY ERROR. PROBABLE CAUSE: M8515 OR SBUS OR MEMORY SYSTEM. SEE CHART B:
	0	1	1	1	0	0	NON-EXISTENT MEMORY ADDRESS DURING AN INTERRUPT. PROBABLE CAUSE: SOFTWARE THOUGHT THERE WOULD BE MEMORY AT THIS ADDRESS OR THE MEMORY SYSTEM DID NOT ACKNOWLEDGE. SEE CHART B:
	0	1	1	1	0	1	SBUS ADDRESS PARITY ERROR DURING AN INTERRUPT. PROBABLE CAUSE: M8515 OR SBUS OR MEMORY SYSTEM. SEE CHART B:
	1	0	0	0	0	0	WITH INTERNAL MEMORY INDICATES INCOMPLETE CYCLE. PROBABLE CAUSE: MBOX OR MEMORY CONTROL LOGIC.
	1	0	0	1	0	0	MEMORY PARITY ERROR ON A SYSTEM WITH A DMA20. PROBABLE CAUSE: SEE CHART B:
	1	0	1	1	0	0	MEMORY PARITY ERROR ON A SYSTEM WITH A DMA20 DURING AN INTERRUPT. PROBABLE CAUSE: SEE CHART B:

COMPANY CONFIDENTIAL

The KL10's error address register (ERA) latches from error conditions that set APR bit 25, 27, 29, or any combination. The following chart reflects MBOX cycles which can easily be described. Other bit combinations will require a considerable amount of concentration and study to determine why they occurred.

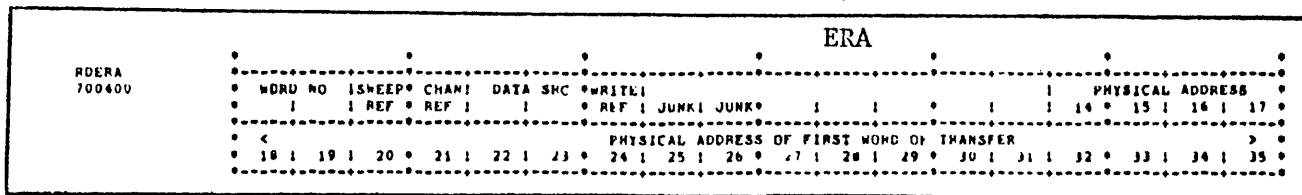

CHART B (ERA):

BIT	02	03	04 & 05		06	CYCLE TYPE:	PROBABLE CAUSE OF APR ERROR CONDITION:
NAME	SWEET	CHAN	DATA	SCR	WRITE		
	0	0	0	0	0	READ OR READ PAUSE WRITE OR CORE READ FOR PAGE REFILL.	CORE - SEE CHART C OR D
	0	0	1	0	1	EBOX STORE (WRITE) FROM AR.	AR - SEE CHART C OR D
	0	0	1	1	0	PAGE REFILL FROM CACHE THROUGH MEMORY BUFFER REGISTERS (MB'S).	CACHE - SEE CHART C OR D
	0	0	1	1	1	WRITE - BACK FROM CACHE FORCED BY WRITE TO CACHE FROM EBOX.	CACHE - SEE CHART C OR D
	0	1	0	0	0	CHANNEL READ FROM MEMORY (CORE).	CORE - SEE CHART C OR D
	0	1	0	0	1	CHANNEL STORE STATUS TO EPT.	CHANNEL - SEE CHART C OR D
	0	1	0	1	1	CHANNEL STORE DATA (WRITE).	CHANNEL - SEE CHART C OR D
	0	1	1	1	0	CHANNEL READ FROM CACHE.	CACHE - SEE CHART C OR D
	1	0	1	1	1	WRITE BACK FROM CACHE FORCED BY SWEEP INSTRUCTION.	CACHE - SEE CHART C OR D

The KL10's with a DMA20 attached to them have an error address register in the DMA which can be read with an SBUS diagnostic cycle to SBUS controller #4. This register latches from error conditions that set APR Bit 24 or 29. The following chart reflects DMA cycles which can easily be described. Other bit combinations will require a considerable amount of concentration and study to determine why they occurred.

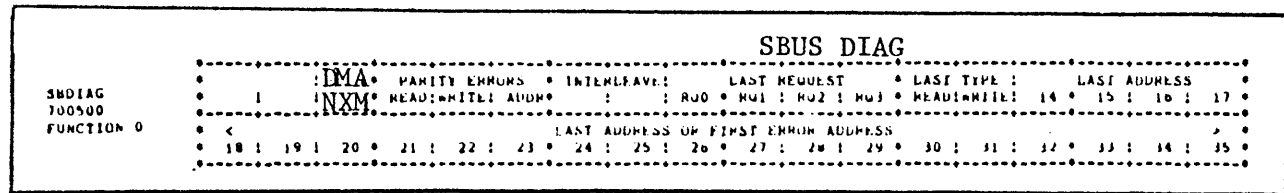

CHART C (DMA20):

BIT	02	03	04	05		
NAME	DMA NXM	RD PAR ERR	WR PAR ERR	ADDR PAR ERR	CYCLE TYPE:	PROBABLE CAUSE:
	0	0	0	1	NONE	MBOX
	0	0	1	0	MEMORY WRITE	MBOX, EBOX
	0	1	0	0	MEMORY READ	EXTERNAL MEMORY
	0	1	1	0	READ PAUSE WRITE	MBOX, EBOX, EXT. MEMORY
	1	0	0	0	ANY (NXM)	EXTERNAL MEMORY

SBUS DIAG																
SBDIAG 700500 FUNCTION 0	-----															
		INCMP	PARITY	ERROR	INTENLEAVE1											
	1	1	1	1	1	1	1	1	1	1	1	1	1	1	1	1

	18	19	20	21	22	23	24	25	26	27	28	29	30	31	32	33

CHART D (INTERNAL MEMORY):

BIT	02	--	05	CYCLE TYPE:	PROBABLE CAUSE:
NAME	INC CYCLE		ADDR PAR ERR		
	0		1	SBUS ADDRESS PARITY	MBOX
	1		0	INCOMPLETE CYCLE	MBOX

COMPANY CONFIDENTIAL

2020 REMOTE (DIAL-UP) INSTALLATION TIPS

BY: M.F. MARTI

M.E.G. - MARLBORO

1. Check the requirements of the modem being used. The "busy" signal jumper might have to be cut on the distribution panel for each channel that is to be a dial-up line. The terminal jacks are counted on the panel from right to left.
2. Inspect the 3A-CONFIG.CMD file for the proper terminal assignments by following the procedure below:
(underlined text is to be typed in)

LOGIN (esc) (USER) F-S (esc) (PASSWORD) F-S (esc)
(account) F-S (ret)

ENA (esc) BLE (CAPABILITIES) (ret)
\$CONN (esc) ECT TO DIRECTORY <SYSTEM> (ret)

\$DIR (esc) ECTORY (ret)

(Verify presence of 3A-CONFIG.CMD File)

TY (esc) PE (FILE) 3A-CONFIG (esc) .CMD (ret)

VERIFY THE FOLLOWING FOR YOUR SYSTEM:

- 1 - The terminal, remote, and speed statements must be made for all dial-up terminals.
- 2 - Ensure there is NO auto statement instead of the speed statement for a dial-up line.
- 3 - Ensure that either one baud rate is specified, or both the input and output baud rates are the same for a dial-up line.
- 4 - Make sure the baud rate specified in this file corresponds to the switch setting on the terminal.

NOTE: Terminal #0 and #1 correspond to the CTY and KLINIK lines, respectively. Therefore, the lowest user terminal number is 2. Terminal #2 in this file corresponds to the right jack on the distribution panel.

NEW LP14 PAPER PULLER MOTOR

BY: BERT LONGO
M.E.G.

A new paper puller motor, Dpc P/N 246716-001, has been introduced by the manufacturer to increase reliability and to improve the motor operating temperature, especially in 50 HZ application.

The reliability improvement is obtained with the new higher torque motor. The operating temperature is improved by mounting the motor away from the printer frame by means of standoffs which allow better air-circulation through the motor endbells.

It is recommended that the old paper puller motor be replaced in all 50 HZ printers as soon as possible. The following procedure should be used when replacing the old motor and the new motor installed.

Cross Reference: LP14-TT-5

LP14 PAPER PULLER MOTOR INSTALLATION PROCEDURE

REMOVAL OF MOTOR ASSY.:

1. Turn printer off (main circuit breaker) and unplug printer from A.C. outlet.
2. Unplug paper puller from printer (reference description A74P1). See figure 3.
3. Unscrew paper puller from rear panel of printer. See figure 3.
4. Remove pulley cover (save cover and hardware).
5. Loosen nuts securing motor.
6. Remove drive belt and 20T pulley from motor (save).
7. Remove 8- 32 nuts and washers securing motor (save).
8. Remove 244502-001 motor, (29-23009-01), 244510-001 drip pan and 243391-001 drip guard from paper puller (discard).
9. Remove 800459-001 strain relief bushing (discard).

INSTALLATION OF NEW MOTOR ASSY: Ref. Figures 1 & 2

10. Place one each 90-06819 (1/4" long) spacer on each motor stud.
11. Install motor into paper puller, see figure 2, using hardware saved from step 7, plus flat washers. Do not tighten nuts.
12. Mount 20T pulley on motor shaft, install drive belt (removed at step 6). Adjust belt tension per figure 2, tighten nuts.
13. Remount pulley cover, saved from step 4.
14. Mount paper puller on rear panel of printer.
15. Plug A74P1 connector into printer.
16. Plug printer into outlet.
17. Turn main circuit breaker on, run printer and test paper puller for correct operation.

(FIGURES 1,2 AND 3 ON FOLLOWING PAGES)

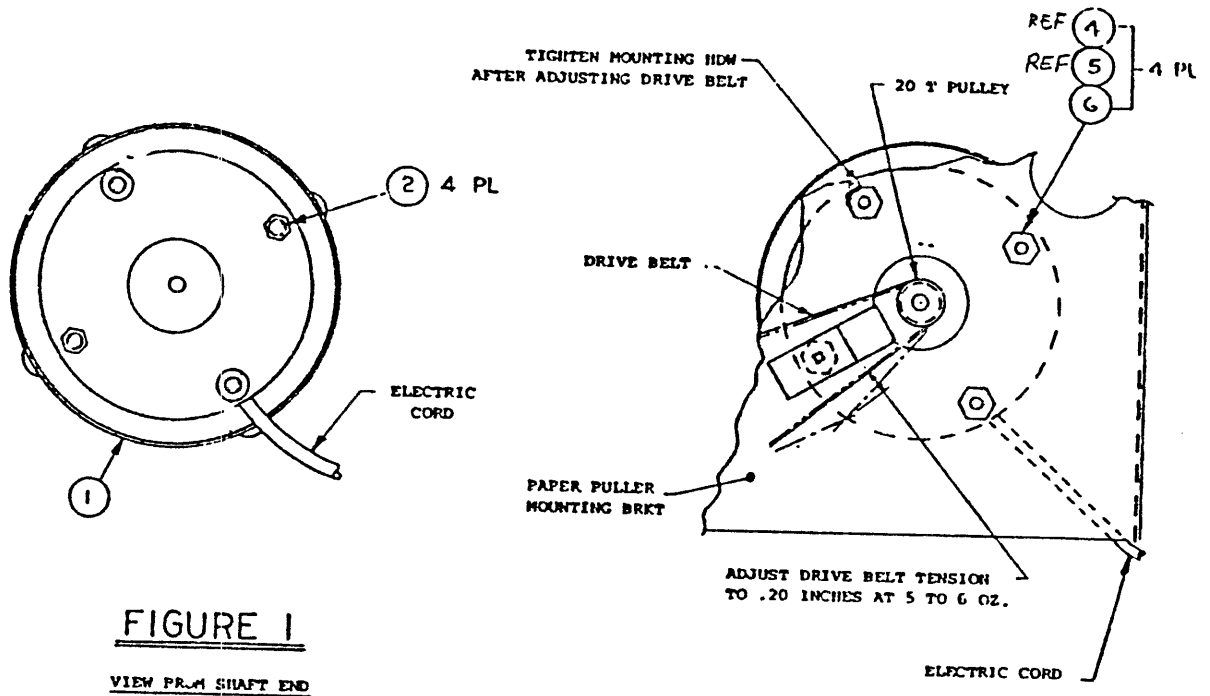

FIGURE 1
VIEW FROM SHAFT END

FIGURE 2
ASSEMBLY DETAIL

BILL OF MATERIALS
(REF. FIGURES 1 & 2)

ITEM NO	QTY.	DEC PART NO.	DPC PART NO.	DESCRIPTION
1	1	29-23009-00	246716-001	ASS'Y. MOTOR
2	4	90-06818	800149-001	SPACER,
4	4	90-06561	800074-004	NUT, HEX #8
5	4	90-06634	800076-004	WASHER, LOCK, INT TOOTH #8
6	4	90-06660	800075-004	WASHER, FLAT #8

NOTE: These parts must be ordered individually.

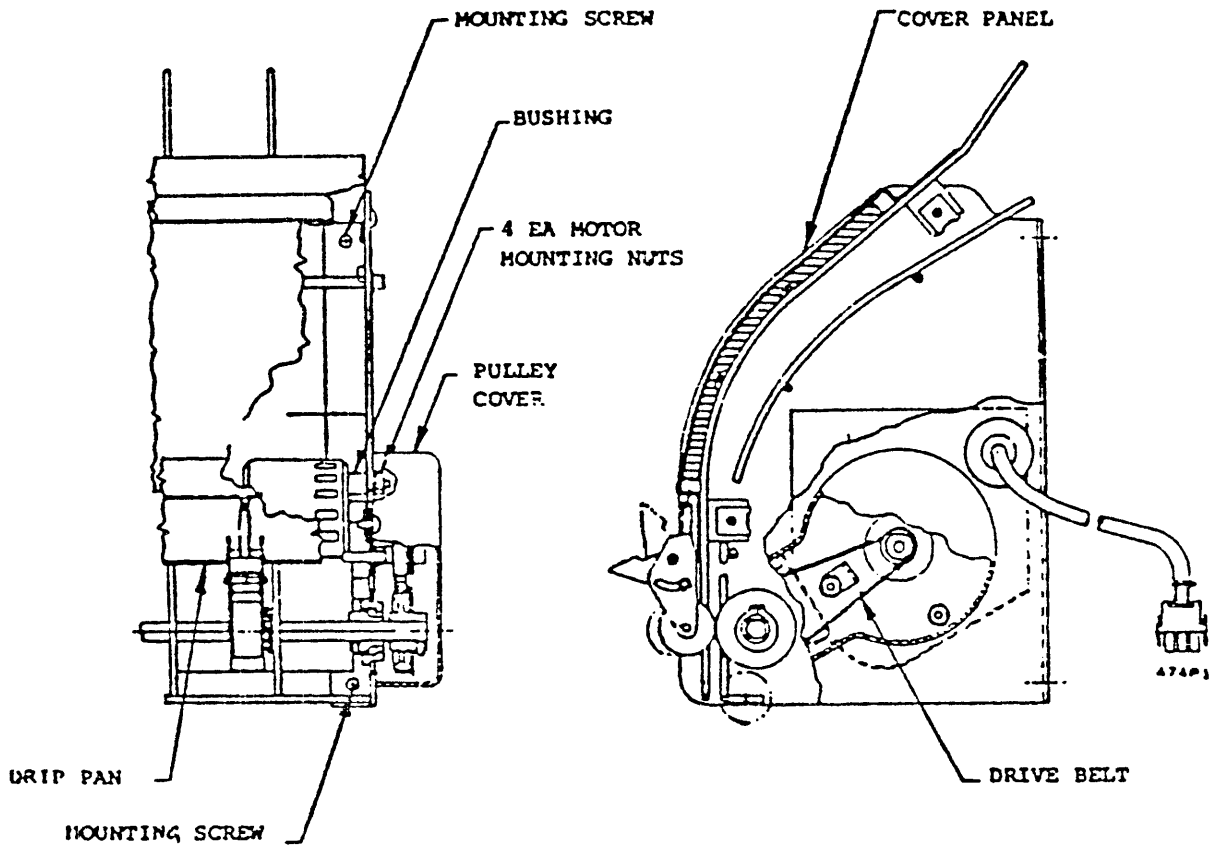

Figure 3 Paper Puller

PATCHES FOR 603 MONITOR

BY: JOHN A. LUTJEN
FIELD SERVICE - SJ

Below are two (2) patches for the 603 monitor:

- MCO #7455 fixes a problem where unprivileged users may gain I/O privileges.
- MCO #8047 prevents privileged users from losing I/O privileges.

NOTE: Strange crashes and system problems have been noticed when these patches are missing.

MCO #7455

[SYMPTOM]

User IOT can get set.

[DIAGNOSIS]

Save context routine saves user IOT also.

[CURE]

In CLOCK 1 at SAVCT3-3

replace

PJRST HOLD

with

JRST [HRRZS JOBPD1##(R)
PJRS HOLD]

[END OF WRITE-UP FILE]

MCO #8047

[SYMPTOM]

User can lose USRIOT privs.

[DIAGNOSIS]

PSISER tries to prevent users giving it to themselves when they don't deserve it but gets everyone even if they do.

[CURE]

Clear all but USRMOD,USRIOT, and PUBLIC from old PC (after storing for user) and make that the flags for new PC.

[FILCOM]

.EDIT 8047

.DATE 19-SEP-78

.MODULE PSISER

.INSERT TOUSR2+1,REPLACE:6,<TLNN P2,(XC,UIO)> ;REPLACE 6 AND INSERT

HLL T2,P2 ;INSERT CURRENT FLAGS

TLZ T2,761777 ;(<-1,,0>-<XC.USR!XC.UIO!XC.PUB>)

.ENDI

.ENDE

[END OF WRITE-UP FILE]

COMPANY CONFIDENTIAL

L.C.G. TECH TIPS

BY: NANCIE MITCHELL
LCG PS QUALITY ASSURANCE

Do you have some technical information which could prove helpful but you're not sure how to go about getting it documented on microfiche as a Tech Tip??? Below, I have outlined some key points you should know when submitting an LCG Tech Tip to Marlboro for publication.

TYPES OF INFORMATION TO BE INCLUDED IN A TECH TIP:

- "Nice to Know" information.
- Helpful troubleshooting techniques.
- Safety precautions.
- Possible problem areas and solutions.
- Information not releasable to customers.
- Preliminary PM's.
- Significant ECO errors.
- Unique product information.
- Pertinent vendor information.

ORIGINATION:

- Anyone in Field Service can generate a Tech Tip.

TECH TIP FORMS:

These forms can be ordered via your literature contact who should then place the order through Communication Services - Northboro.

- Page 1 - Form #EN-1189C-12-R277-(79Y)
Field Service Technical Manual } This form is to be used when originating a Tech Tip.
- Page 2 - Form #EN-1190B-12-R277-(79Y)
Field Service Technical Manual } To be used only when a Tech Tip is more than one page long.

NOTE: When ordering these forms specify "RED" ink.

(CONT. NEXT PAGE)

HOW TO FILL OUT THESE FORMS:

- Tech Tips should be typed in Large lettering, if possible.
- The title block should contain an explicit, comprehensive title. The title and option should be compatible.
- Author's Name.
- Field Service Office.
- Manager/Supervisor Name (plus signature).
- Date Prepared.
- The Revision block gives the revision level of the entry. Revision 0 for an initial Tech Tip; Revision A,B,C, etc., for subsequent changes to the same Tech Tip.
- Processor Applicability is used to designate the processor type to which the Tech Tip relates. i.e.: 10/20.

THE TEXT:

- When a Tech Tip is generated to resolve a problem, the problem will be explained first, then the solution.
- All illustrations should be of production quality, if possible.
- All information must be complete but concise.

Upon completion of the Tech Tip and your Manager's/Supervisor's approval, forward it onto:

NANCIE MITCHELL - MR1-1/S35
LCG Tech Tip Coordinator

Once the Tech Tip is received in Marlboro the following steps take place:

- Assigning the Tech Tip to the Product Support Engineer responsible for that particular option for review.
- Assigning approved Tech Tips a sequential number and arranging the Tech Tips on a production master for publication.
- Upon approval of a Tech Tip a copy will be forwarded to the LCG Product Support Supervisors and to the originator with a cover memo explaining when to expect to see your Tech Tip on microfiche.

(Any disapprovals will be returned and accompanied with an explanation to the originator).

- Ensure Tech Tip is published.

Again, hopefully the steps outlined above have cleared up some of the questions you might have had regarding Tech Tips and didn't know who to ask. Any further questions or problems please feel free to contact me.

COMPANY CONFIDENTIAL

FIX FOR SBDIAG'S ON 1091

BY: JACK WALDEN

LCG PRODUCT SUPPORT - MARLBORO

The attached MCO is the code necessary to have SBDIAG's done for internal memories on 1091 systems. This code is only for 1091 systems and can go equally well in 6.03 or 6.03A. This code has already been implemented in 7.01.

While I realize that this is a fair amount of code, the importance of it as a tool to help fix 1091's outweighs the size of this fix.

MCO #8402

IN COMMON

AT APONHT+2

DELETE BOTH SBDIAG INSTRUCTIONS

INSERT PUSHJ P,SBUSTS##

IN CLOCK 1

AT APPCP1+4

REPLACE MOVE T3,[100000,,0]
SBDIAG T3
DMOVEM T3,.CPPSB##(P4)
MOVE T3,[100000,,1]
SBDIAG T3
DMOVEM T3,.CPPSB##T2(P4)
MOVSI T3,110000

WITH PUSHJ P,SBUSTS##

AT APPCP2+1

REPLACE SBDIAG T3

WITH PUSHJ P,SBCLR##

(CONT. NEXT 2-PAGES)

COMPANY CONFIDENTIAL

IN KLSER

AT PRTRP+36

```

REPLACE MOVE T1,[100000,,0]
          SBDIAG T1
          DMOVEM T1,.CPPSB##(P4)
          MOVE T1,[100000,,1]
          SBDIAG T1
          DMOVEM T1,.CPPSB##+Z(P4)
          MOVSI T1,DMACLR
          SBDIAG T1
    
```

WITH PUSHJ P,SBUSTS##

AT PRTP1-2
 AT PRTP3+15
 AT PRHMF+15
 AT PRHMF+35
 AT MPSLP3+2

```

REPLACE MOVSI T1,DMACLR
          SBDIAG T1
    
```

WITH PUSHJ P,SBCLR##

AT THE END OF THE KLSER ADD THE FOLLOWING CODE:

```

;HERE TO PERFORM SBDIAG FUNCTIONS 0 AND 1 FOR EACH MEMORY CONTROLLER
;IN A 1091 AND TO CLEAR THE ERROR FLAG.
; THE FORMAT OF THE SBDIAG STATUS BLOCK IS AS FOLLOWS.
;   WORD0: -NUMBER OF DATA BLOCKS,,OFFSET TO FIRST BLOCK
;
;DATA BLOCK FORMAT:
;   WORD0: -NUMBER OF WORDS,,CONTROLLER NUMBER
;   WORD1: SBDIAG FUNCTION 0 RETURN WORD
;   WORD2: SBDIAG FUNCTION 1 RETURN WORD
;
;CALL IS
;   PUSHJ P,SBUSTS
;
;DEFINE SOME NEEDED VALUES
.SBNMC==4 ;THE NUMBER FOR INTERNAL CONTROLLERS
.SBFNC==3 ;THE NUMBER OF WORDS IN DATA BLOCK
SB.CON==20000 ;RIGHT-MOST BIT OF CONTROLLER NUMBER IN SBDIAG
;TO MEMORY WORD
SB.CLR==10000 ;LEFT-HALF BIT TO CLEAR ERROR FLAGS IN SBDIAG
;FUNCTION 0
.SBLSH==^D36-^L<SB.CON>-1 ;NUMBER OF BITS TO LEFT SHIFT
;A RIGHT JUSTIFIED CONTROLLER NUMBER TO POSITION
;IT FOR SBDIAG.
    
```

COMPANY CONFIDENTIAL

```

SBUSTS::PUSHJ P,SAVT##
        HRLZI T1,-.SBNMC      ;-NUMBER OF MEMORY CONTROLLERS
        HRLI  T1,1           ;FIRST BLOCK STARTS AT WORD1
        MOVEM T1,.CPSBD      ;SAVE AS WORD0 OF SBDIAG STATUS BLOCK
        MOVEI T2,.CPSBD+1    ;POINT TO FIRST DATA BLOCK
SBUST1::HRLZI T3,-.SBFNC     ; - NUMBER OF WORDS IN DATA BLOCK
        HRLI  T3,-1(T1)     ;GET CONTROLLER NUMBER
        MOVEM T3,0(T2)      ;STORE AS WORD 0 OF THIS DATA BLOCK
        LSH   T3,.SBLSH     ;SHIFT OFF CONT AND POSITION CONROLLER
                                ;NUMBER
        TLO   T3,SB.CLR     ;SET BIT TO CLEAR ERRORS
        SBDIAG T3           ;DO SBDIAG FUNCTION 0
        MOVEM T4,1(T2)      ;STORE RETURNED WORD AS WORD1 OF BLOCK
        TRO   T3,1         ;CHANGE TO FUNCTION 1
        TLO   T3,SB.CLR     ;TURN OFF CLEAR ERROR
        SBDIAG T3           ;DO SBDIAG FUNCTION 1
        MOVEM T4,2(T2)      ;STORE RETURNED WORD AS WORD2 OF BLOCK
        ADDI  T2,.SBFNC+1   ;BUMP STATUS BLOCK POINTER BY
                                ;LENGTH OF DATA BLOCK
        AOBJN T1,SBUST1     ;LOOP FOR ALL MEMORY CONTROLLERS
        PUSH  P,T1
        PUSH  P,T2
        PUSH  P,J
        MOVEI T1,17         ;ENTRY TYPE
        HRLI  T1,.CPSBD     ;POINTER WORD FOR DATA
        PUSHJ P,DAEEIM##    ;MAKE ENTRY
        POP   P,J
        POP   P,T2
        POP   P,T1
        POPJ  P,
    
```

```

;ROUTINE TO ONLY CLEAR ERRORS WITH SBDIAG
;CALL IS
;   PUSHJ P,SBCLR
    
```

```

SBCLR:  PUSH  P,T1
        PUSH  P,T2
        HRLZI T1,-.SBNMC     ;GET NUMBER OF CONTROLLERS
SBCLR1: HRLI  T2,-1(T1)     ;GET CONTROLLER NUMBER
        LSH   T2,.SBLSH     ;POSITION CONTROLLER NUMBER
        TLO   T2,SB.CLR     ;SET BIT TO CLEAR ERRORS
        SBDIAG T2          ;DO SBDIAG CLEAR
        AOBJN T1,SBCLR1     ;LOOP FOR ALL MEMORY CONTROLLERS
        POP   P,T2
        POP   P,T1
        POPJ  P,           ;RETURN
    
```

```

$LOW
.CPSBD:BLOCK <.SBNMC>*.SBFNC+1
$HIGH
    
```

GOODSTUFF INDEX

ISSUE #18 - MAY F.Y. 79

SPEC DISCREPANCY FOR
THE -5V SUPPLY

BY: Roy Sequeira
PRODUCT SUPPORT - KANATA

For your information, there is a discrepancy in specs for the -5v supply used in the RH20 DTE/DMA/DIA backplane.

The prints for these devices refer to this voltage as being -5.2v. The backplane diagram refers to it as being -5.0v.

The correct value for this voltage is -5.0v.

NOTE: Spec being corrected.

- HOW TO ORDER THE KL10 MAINTENANCE GUIDE
- DIAGNOSTIC PROBLEMS
- KL MODEL B CPU - ALERT
- QUALITY OF FIELD SERVICE SPARES OVERVIEW
- PITRAP BUGHLTS AND AR/ARX PARITY PROBLEMS IN TOPS-20
- KL10 ERROR REGISTERS
- 2020 REMOTE (DIAL-UP) INSTALLATION TIPS
- NEW LP14 PAPER PULLER MOTOR
- PATCHES FOR 603 MONITOR
- L.C.G. TECH TIPS
- FIX FOR SB DIAG'S ON 1091
- SPEC DISCREPANCY FOR THE -5V SUPPLY

(CLIP & MAIL)

WANT TO RECEIVE GOODSTUFF...

Simply fill out this card and drop it in the nearest interoffice mailbox.

(PLEASE PRINT)

NAME: _____

U.S. BADGE #: _____

FS COST CENTER: (700's only) _____

LOCATION CODE/ADDRESS: _____

Do you wish to have back copies?

YES

NO

NOTE: It takes approximately one-month to appear on the distribution once this registration card is received.

Any questions please contact Nancie Mitchell - MR1-1/S35 - TWX Code: MR11

THE FOLLOWING ISSUES OF GOODSTUFF ARE DOCUMENTED ON MICROFICHE:

●MARCH ISSUE #16 - APPEARS ON SPEED BULLETIN #75
3-19-79

●APRIL ISSUE #17 - APPEARS ON SPEED BULLETIN #77
3-09-79

RETURN TO:

NANCIE MITCHELL

MR1-1/S35

GOOD STUFF

This document contains sensitive information which shall not be disclosed to personnel outside of Digital Equipment Corporation.

This Newsletter is meant as an information document. It's contents are not necessarily Company Policy. It's a means by which LCG Product Support can distribute some tidbits of information to you.

ISSUE NO. 19

• • •

JUNE FY 79

We would like to take this opportunity to say "thank you" to each of you who has participated in any of the Goodstuff Issues for Fiscal Year '79.

Your inputs have enabled us to maintain and publish what we feel is an extremely valuable tool for all Field Service employees. Without the interest each of you has shown and the quality of information submitted for publication, Goodstuff could not exist.

We are looking forward to our 2nd year of publication in hopes that we can make Goodstuff an even higher quality publication than it already is.

Thanks again for your excellent inputs and enthusiastic participation.

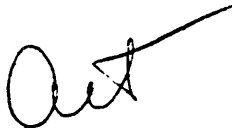

Art O'Donnell

COMPANY CONFIDENTIAL

CORRECTION

I/O PAGE FAIL ERRORS AND COP
STOPCODES IN 1090 SYSTEMS
BY: PAUL CLARK

Please make the following corrections and additions to your issue #17 of Goodstuff.

- 1) Page #7 paragraph 6 says "delay switches set to 640." Change it to "delay switches set to 450."
- 2) Page #9 at bottom it says "delay switch to 240." Change it to read "delay switch to 240 for 1650 D or 480 for 9100D."
- 3) Page #10 at bottom it says "delay switches to 640." Change it to read "delay switches to 450 for 1650D or 900 for 9100D "

SORRY FOR THE CONFUSION!

SET THAT DN20 PARITY

BY: BOB MALONEY
LCG PRODUCT SUPPORT - MARLBORO

If you are using an 1134 CPU with your DN20, memory parity errors may not be flagged.

Refer to the April 1, 1979, software dispatch, SPR #10-27432, to correct this problem.

DN92 SWITCH SETTING

BY: PETE CRIBB
LCG PRODUCT SUPPORT - MARLBORO

The switch 1-8 on the M8315 (PDP8A) is listed incorrectly in the procedure and the prints. They say it should be in the ON position, but ECO M8315-0004 says to be sure that it is in the OFF position to prevent possible system hangs.

If you have a DN92 on your system please make sure that it is in the OFF position.

Cross Reference: DN92-TT-1

<p>EDITORArt O'Donnell ASSOC. EDITOR...Nancie Mitchell EDITORIAL OFFICEMR1-1/S35</p> <p>GOODSTUFF is published on a monthly-basis.</p>

COMPANY CONFIDENTIAL

TX02 SPARES

BY: KEITH PARKER
IN HOUSE FIELD SERVICE - MARLBORO

While troubleshooting a TX02 recently, I came across a problem with finding a part from stock. Looking up the STC number using LOGPIC, I found that the part pulled from stock using the DEC part number was not physically the same as the part being replaced. Also, I found the STC number sometimes was not listed at all and the only way to find the part was to match the slot location of the module and/or STC card letter designation.

Further investigation found that DEC, stocks parts for the TX02 AA/AB, dual channel TCU compared to the TX02 AA most of us presently have. Therefore, the part found in stock will work; it is physically different due to double the logic for a 2 channel TCU, but electronically the same module.

RM03 JUMPER FOR LCG

BY: J.GANNELLI/M.RONAYNE
LCG PS QUALITY/MANUFACTURING ENG.

All RM03's require a jumper on the MBA backplane for compatibility with LCG Software. This jumper goes from E06E1 (BP144 ENB H) to E06C2 (GND).

All F.A.&T.ed RM03's should have this jumper already in place. However, dock merged and field merged drives will not have this jumper present.

REFERENCE:

RM02/03 DISK SUBSYSTEM USERS GUIDE - #EK-RM023-UG-001 Page 4-55 table 4-22.

RM03 FIELD MAINTENANCE PRINTSET - PRINT DS6 - Sheet 6 of 15 coordinates C3 signal name BP144 ENB H.

Note:

This jumper inhibits bad sector error from coming up as a result of MF or UF bits being true in first header word. LCG does not use these bits to flag bad sectors while 11-land does (per DEC STD 144).

CROSS REFERENCE: RM02/03-TT-11

COMPANY CONFIDENTIAL

LP07 BAND GATE IMPROVEMENTS

BY: BERT LONGO

M.E.G.

Significant improvements to the LP07 (DpC Model 2550) band gate assembly were incorporated in the Design Improvement (DI) printers beginning with Vendor S/N B0324.

The improvements (See Table) are presented to ensure that the correct parts are ordered, according to the printer S/N on-site.

- The ribbon deskew motor, the dual lobe cam and link assembly, located on the left side of the band gate, were replaced via FCO LP07-MR-014 (VFO #6492). The old parts are no longer available. Insure that the FCO is in place.
- Changes to the right side of the band gate assembly affect the pivot arm, the cam and the two ribbon drive spools. DI and NON-DI components cannot be mixed. The band gate electronics board also cannot be mixed.
- The ribbon holder on the left side of the band gate has not been changed. The part numbers are presented for your convenience.
- Mixing components will result in serious malfunction and ribbon short life.

CONT. NEXT PAGE ...

LP07 BAND GATE IMPROVEMENTS

(NON-DI VS. DI P/N)

ITEM	DESCRIPTION	VENDOR PART NUMBER			MANUAL FIGS. (REF.)	DEC P/N 29-	COMMENTS
		NON-DI	DI				
			WAS	IS			
1	RIBBON DESKEW MOTOR (LEFT)	239408-001		245295-001	9-43 9-35	22365-XX 23140	NON DI MOTOR WAS REPLACED VIA FCO LP07-MR-014 OF DI PROJECT
2	DUAL LOBE CAM (LEFT)	241026-001		245260-001	9-43 9-35	N/A N/A	NON DI CAM REPLACED VIA FCO LP07-MR-014 OF DI PROJECT
3	LINK ASSEMBLY (LEFT)	241027-001		245229-001	9-43 9-35	N/A N/A	NON DI LINK REPLACED VIA FCO LP07-MR-014 OF DI PROJECT
4	RIBBON HOLDER (LEFT)	231061-001		231061-001	9-43 9-35	23289 23289	NO CHANGE
5	BAND GATE ELECTRONICS PCBA	239470-001		239470-003	9-111 9-25	23370 23371	NON-DI PCBA NOT INTERCHANGEABLE WITH DI PCBA
6	RIBBON SHIELD	238294-001		245274-001	9-2 9-2	22349 23318	NON-DI SHIELD NOT INTERCHANGEABLE WITH DI
7	PIVOT ARM (RIGHT)	236930-001		245226-001	9-31 9-33	23362 23364	NON-DI PIVOT ARM NOT INTERCHANGEABLE WITH DI
8	CAM (RIGHT)	236214-001		245277-001	9-31 9-33	23365 23363	NON-DI CAM NOT INTERCHANGEABLE WITH DI
9	SPOOL, RIBBON DRIVE, LOWER (RIGHT)	237088-001	244287-001	251330-001	9-31 9-33	23290	PARTS INTERCHANGEABLE
10	SPOOL, RIBBON DRIVE, UPPER (RIGHT)	236541-001	244287-002	251330-001	9-31 9-33	23291	PARTS INTERCHANGEABLE

NOTES:

- | | |
|-----------------------------------|---|
| 1. XX = OBSOLETE | 4. N/A = NOT AVAILABLE |
| 2. NON-DI = DpC S/N B0323 or LESS | 5. NON-DI MANUAL P/N = DpC 238811 REV D or E = BLOCK TOP FIG. # |
| 3. DI = DpC S/N B0324 or GREATER | 6. DI MANUAL P/N = DpC 245035 = BLOCK BOTTOM FIG. # |

COMPANY CONFIDENTIAL

TU72 EVE DRIVE

BY: STAN SCHULTZ

IHFS - DISTRICT SUPPORT - MAYNARD

INTERMITTENT PROBLEMS:

Cause:

Vibration of the fan can rub off insulation on cables that are routed so that they touch the fan.

Solution:

Install two 8" long strips of self-adhesive foam strips side-by-side on the fan to insulate cable #90-8881 and tape up worn insulation, if observed.

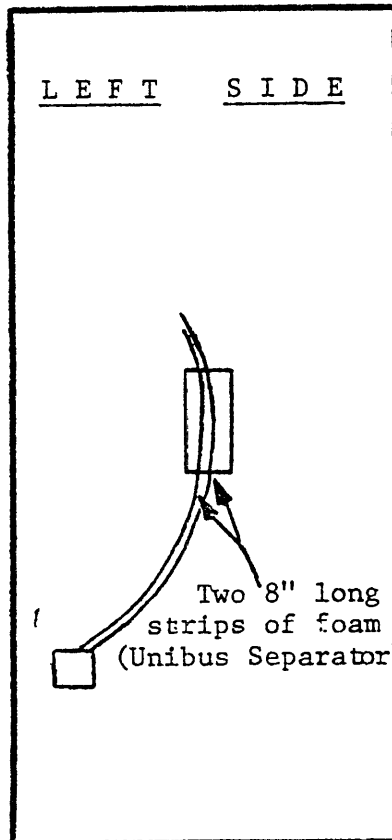
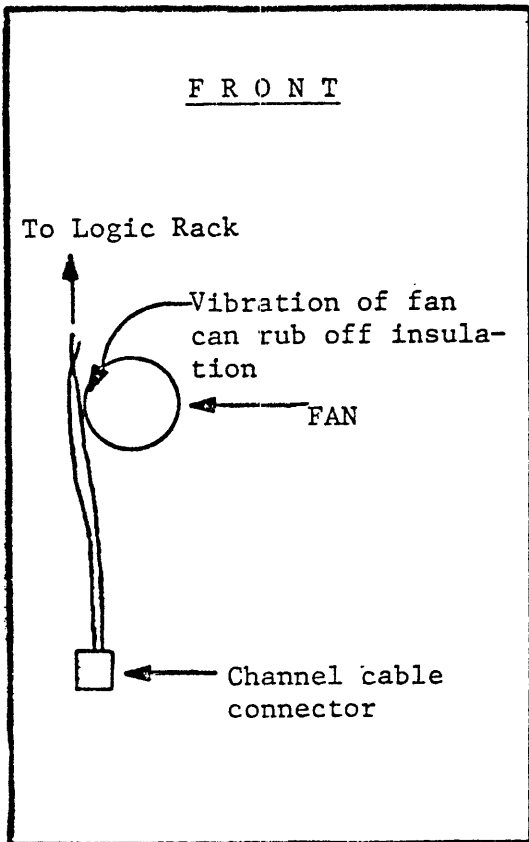

COMPANY CONFIDENTIAL

ONE THING YOU CAN DO IF SPAR DOESN'T RUN ON YOUR TX01/TX02

BY: SCOTT SITTERLY
IN HOUSE FIELD SERVICE - MARLBORO

I once had a problem where the spar tape wouldn't move which turned out to be a problem with the GPC counter. Another time I had a problem where spar would take off, appear to fail, and gave me an error code that didn't exist. In this case, the micro-code decoding circuitry was broken, however, one of the symptoms was you couldn't load the GPC properly.

I decided to write an eight-step micro-code test to check if you can properly load the four bytes of the GPC.

<u>ADR</u>	<u>INSTR</u>	
780	CF01	WILL LOAD F IN THE FIRST BYTE = F000
781	4F42	WILL LOAD F IN THE SECOND BYTE = FF00
782	CF83	WILL LOAD F IN THE THIRD BYTE = FFF0
783	CFC4	WILL LOAD F IN THE FOURTH BYTE = FFFF
784	4005	WILL LOAD 0 IN THE FIRST BYTE = OFFF
785	C046	WILL LOAD 0 IN THE SECOND BYTE = OOFF
786	4087	WILL LOAD 0 IN THE THIRD BYTE = 000F
787	40C0	WILL LOAD 0 IN THE FOURTH BYTE = 0000

To deposit this program into the ram that spar uses to load his tests, do the following: (Note: the off-line, spar, man ld, and write earom switches are all in the same row). The set romar switch is below the romar register. The romar address switches are used to select the appropriate address. The display B switch can not only be used to select the register you want displayed in the display B lights, but also has the setting 0 - F which is what you use to select the first byte of the instruction you wish to deposit into ram. The FE buffer ADR switch is used to select the second byte of the instruction and the FE buffer data switches are used for the third and fourth byte of the four byte instruction.

1. PUT UP THE OFF-LINE, SPAR, AND MAN LD SWITCHES
2. PUT THE ADDRESS 780 IN THE ROMAR ADDRESS SWITCHES
3. PUT THE FIRST BYTE OF THE INSTRUCTION "C" IN THE DISPLAY B SWITCHES
4. PUT THE SECOND BYTE OF THE INSTRUCTION "F" IN THE FE BUFFER ADR SWITCHES
5. PUT THE NEXT TWO BYTES OF THE INSTRUCTION "01" IN THE FE BUFFER DATA SW
6. NOW PUSH THE WRITE EAROM AND SET ROMAR SWITCHES MOMENTARILY TO DEPOSIT
7. TO CHECK IF LOADED CORRECTLY, PUT THE DISPLAY A & B SWITCHES TO ROMSL

COMPANY CONFIDENTIAL

To load the next instruction 4F42 into location 781, change the romar address to 781 and the display B to 4, the buffer address to F, and the buffer data to 42. Do step 6 to deposit and 7 if you want to check (and so on for 782 through 787). I usually deposit the whole program and then check it by stepping from 780 to 787 with the romar address sw with display A & B switches set to ROMSL as my last step. The P bits of display A & B aren't being used.

Once the program is loaded put the man ld sw down, set the romar address switches to 780, set the rate normal switch to "ROM - SINGLE", push reset, push stop, set romar, and with the display A & B switches set to GPC, push start. The romar address should have stepped to 781 and the GPC should = F000. The P bits aren't being used. Hit start again and romar address should step to 782 and the GPC should = FF00 and etc. To look fancy you can put the rate normal sw to "ROM - MULTIPLE" and hold the start switch. You can watch the F pattern float in and out of the GPC. Also, for scoping, you can put the rate normal switch in the normal position.

If you get any ROM ACC errors then you made a mistake in depositing the program and are getting memory parity errors. With the display A & B switches set to ROMSL, bit 0 of display A is the parity bit. (The P bits of display A & B, as stated before, aren't being used). It's very easy to forget to change the display B switch from 4 to C when depositing the program, in which case the program will work but you'll get ROM ACC errors.

CROSS REFERENCE: TU70/71-TT-16

EXECUTING AN SBUS DIAGNOSTIC

BY Walter B Johnson
D.D.C.

When you execute and SBUS diagnostic function 1 to either and MA20 or an MB20 bit 13 suggests the memory has detected a power fail This is impossible because the gate on MAC5 is grounded in both cases.

To verify- check MA20-0-MAC5 8561 and MB20-0 MAC5 8568.

The following issue of Goodstuff is documented on microfiche:

- Issue #18 - May '79 - appears on Speed Bulletin #002 - May 14, 1979.

COMPANY CONFIDENTIAL

CORE MAP OF RSX20-F
BY: ROY SEQUEIRA
PRODUCT SUPPORT - KANATA

The following is a core map of RSX20-F (TOPS20, V3A). It will be useful to find out what the 11 is doing in case of a system hang.

RSX20F MAP IN 11 CORE.
TOPS-20, VERSION 3A

	<u>NAME</u>	<u>FROM</u>	<u>TO</u>	<u>FUNCTION</u>
1.	LC	0000	1563	Trap & Interrupt vectors
2.	SCH	1564	5357	Handles traps and task scheduling
3.	BOOT	5360	7107	Handles booting the KL
4.	PF	7110	7625	Handles power fails.
5.	DMDTE	7626	11101	Handles all DTE directives
6.	DMASS	11132	11235	Assigns Logical Unit Nos.
7.	DMGLI	11236	11401	Directive for information about assigned LUNS.
8.	DMGTP	11266	11401	Directive for time information
9.	DMSSED	11402	11717	Significant event flag handler.
10.	DMMKT	11720	12021	Mark time directive handles waiting for significant events.
11.	DMCMT	12022	12067	Cancel Mark time directive.
12.	DMSUS	12070	12175	Suspend and resume directives.
13.	DMEXT	12176	12217	Exit directive.
14.	DMQIO	12220	12671	QIO directive.
15.	DMSAR	12672	13311	Send and receive directives.
16.	DMSDV	13312	13323	Record synch system trap entry pts.
17.	DMAST	13324	13345	Record power fail outline for device.
18.	DMREQ	13346	13573	Make task active and runnable.
19.	DMGPP	13574	13715	Get and store task information.

COMPANY CONFIDENTIAL

RSX20F MAP IN 11 CORE.
TOPS-20, VERSION 3A

<u>NAME</u>	<u>FROM</u>	<u>TO</u>	<u>FUNCTION</u>
20. DMGMP	13716	14047	Get and store partition information for task.
21. RUN	14050	14257	Check time dependent clock flags on a clock tick.
22. QPRDTE	14260	22441	DTE driver and queued protocol handler
23. TTYDRV	22442	31201	Terminal device driver.
24. SCOMM	31202	44721	RSX20F exec data base.
25. ARITH	44722	45011	Misc arith functions.
26. DBDRV	45012	46671	Dual ported disk driver.
27. DXDRV	46672	50353	Floppy disk driver.
28. FEDRV	50354	52247	Pseudo devive FE: driver.
29. LPDRV	52250	57331	Line printer driver
30. CRDRV	57332	61655	Card reader driver.
31. INSTAL	61656	65215	Task that installs a task into the GEN partition.
32. .FREPL	70000	75777	Free pool
33. .BGBUF	76000	77777	Big buffer.
34.	100000	145377	GENERAL PARTITION.
35. FL1TPD	14500	157777	Files-11 functions.
36.	160000	177777	I/O address area.

COMPANY CONFIDENTIAL

ABNORMALLY HIGH MAGTAPE PARITY ERRORS ON TOPS-10 2020

BY: IRA MACHEFSKY
SOFTWARE SERVICES - MARLBORO

The following MCO was written after the KS-10 LIR was shipped. It is easy enough to insert with the enclosed MAKLIB FIX file, and we recommend that all TOPS-10 2020 sites install it.

```
.Edit      8420                ;MCO NUMBER
                                ;APPLIES TO: KS
;
;
;[SYMPTOM]
;
;      Abnormally high number of magtape parity errors when
;monitor retries are enabled.  In particular, this is most
;noticeable to users of BACKUP.  Problem on KS-10 only.
;
;[DIAGNOSIS]
;
;      RDREGS routine is smashing register containing current
;function word.
;
;[CURE]
;
;      Change register usage at RDREG1 and RDREG1-1 to T4 from
;P1.
;
;Name   ISM
;Date   13-Mar-79
;MODULE TRHKON
;INSERT RDREG1-1,REPLACE, <MOVE P1,[POINT 6,RH110F]>
;        MOVE    T4,[POINT 6,RH110F]
;ENDI
;INSERT RDREG1,REPLACE,<ILDB T2,P1>
;        ILDB    T2,T4
;ENDI
;ENDE
```

NOTE: This article originally appeared in The Large Buffer -
Vol. 454, 5-Apr-79.

COMPANY CONFIDENTIAL

CLEAR CORE ROUTINE FOR KL10'S

BY: CLIFF ROMASH
REGIONAL PRODUCT SUPPORT - WALTHAM

The following little routine is useful to clear all of core, including shadow memory and core above 256K, on a KL10/20. Contents of 2 have to be set at the highest address that exists. Sorry, but the program won't work too well with holes in memory.

This example is for 512K. Just change AC2 for other memory sizes (e.g.: 2,,777777 for 768K; 3,,777777 for 1024K). Start the program at 3.

```

2/      1      777777      ;LAST ADDRESS FOR 512K
3/ 700200    200000      ;RESET WORLD
4/ 242100    777767      ;TURN ADDRESS INTO PAGE #
5/ 201002    700000      ;MAKE PAGE MAP POINTER TO PAGE
6/ 505000    700000      ;AND ONE FOR PAGE 0
7/ 202000    600         ;PUT THEM IN SLOTS FOR EXEC PAGE 0 + 1
10/ 701200   20000      ;TURN ON PAGING, BUT NO CACHE
11/ 402000   1000       ;CLEAR VIRTUAL 1000
12/ 201040   1001       ;
13/ 505040   1000       ;BUILD BUT POINTER
14/ 251040   1777       ;CLEAR EXEC PAGE 1
15/ 365100   5          ;DECREMENT PAGE # AND LOOP
16/ 254200   16         ;HALT WHEN DONE

```

(CLIP & MAIL)

DSTUB PROBLEMS
BY: CLIFF ROMASH
F S. WALTHAM

DSTUB V.1 will get spurious errors on all attempt-to-transfer data if you default the device selection. It will appear to be failing with NEM set in the RH11 CS2 register (3772450).

To get around the problem, be sure to start the diagnostic and specify all the answers to the device selection questions, don't take any defaults.

WANT TO RECEIVE GOODSTUFF ...

Simply fill out this card and drop it in the nearest interoffice mailbox.
(PLEASE PRINT)

NAME: _____

U.S. BADGE #: _____

F.S. COST CENTER: (700's only) _____

LOCATION CODE/ADDRESS: _____

Do you wish to have back copies?

YES NO

NOTE: It takes approximately one-month to appear on the distribution once this registration card is received.

Any questions please contact Nancie Mitchell - MR1-1/S35 - TWX Code: MR11

COMPANY CONFIDENTIAL

INDEX - 3RD QUARTER F.Y. '79

GOODSTUFF - INDEX

ISSUE 17 - APRIL '79
3rd QUARTER

- STOP THAT BUG!
- 603A AND DUAL-PORTED DISKS
- KL10 MAINTENANCE GUIDE - USE AND DURABILITY
- TOPS10 SYSERRR CHANNEL ERROR LOGGING
- WARNING - KL MODEL B CPU
- RP05/6 "LAMP MATRIX" PROBLEMS
- RSX20F AND KEEP-ALIVE-CEASED
- I/O PAGE FAIL ERRORS AND COP STOPCODES IN 1090 SYSTEMS
- TECHNICAL ASSISTANCE CENTER
- MF20 MAINTENANCE NOTES
- RH20 MASSBUS CONNECTORS (KL10)
- SAVING ERROR.SYS ON TAPE
- THANKS FOR YOUR HELP!
- THE TRUTH ABOUT KLERR
- RP06 ABSOLUTE FILTER CHECK
- KS10 UNIBUS TERMINATION

GOODSTUFF INDEX

ISSUE #18 - MAY F.Y. 79
3rd Quarter

- HOW TO ORDER THE KL10 MAINTENANCE GUIDE
- DIAGNOSTIC PROBLEMS
- KL MODEL B CPU - ALERT
- QUALITY OF FIELD SERVICE SPARES OVERVIEW
- PITRAP BUGHLTS AND AR/ARX PARITY PROBLEMS IN TOPS-20
- KL10 ERROR REGISTERS
- 2020 REMOTE (DIAL-UP) INSTALLATION TIPS
- NEW LP14 PAPER PULLER MOTOR
- PATCHES FOR 603 MONITOR
- L.C.G. TECH TIPS
- FIX FOR SBDIAG'S ON 1091
- SPEC DISCREPANCY FOR THE -5V SUPPLY

GOODSTUFF - INDEX

ISSUE #19 - JUNE FY 79
3rd Quarter

- Correction I/O PAGE FAIL ERRORS AND COP STOPCODES IN 1090 SYSTEMS
- SET THAT DN20 PARITY
- DN92 SWITCH SETTING
- TX02 SPARES
- RM03 JUMPER FOR LCG
- LP07 BAND GATE IMPROVEMENTS
- TU72 EVE DRIVE
- ONE THING YOU CAN DO IF SPAR DOESN'T RUN ON YOUR TX01/TX02
- EXECUTING AN SBUS DIAGNOSTIC FUNCTION
- CORE MAP OF RSX20-F
- ABNORMALLY HIGH MAGTAPE PARITY ERRORS ON TOPS-10 2020
- CLEAR CORE ROUTINE FOR KL10 S
- DSTUB PROBLEMS



stuff

COMPANY CONFIDENTIAL

This document contains sensitive information which shall not be disclosed to personnel outside of Digital Equipment Corporation.

This Newsletter is meant as an information document. Its contents are not necessarily Company Policy. It's a means by which LCG Product Support can distribute some tidbits of information to you.

IN THIS ISSUE...

●DIAGNOSTICS

- HOW TO DUMP THE CONTENTS OF A DCL'S REGISTERS. Page 3
- MODEM CONTROL DIAGNOSTICS (DZDHK) WON'T RUN ON A DC 20?. . . Page 4
- KLINIK/DGQDF INTERACTION Page 6

●HARDWARE

- LP10 DROPPING READY INTERMITTENTLY Page 7
- TU45 LOAD PROBLEMS Page 7
- TGHA SOFTWARE FOR MOS MEMORY Page 8
- SCOPING STC DRIVE SIGNALS AT THE CABLE Page 9
- 2020 HALT STATUS BLOCK PROBLEM Page 12
- POTENTIAL SHORT CIRCUIT - TU72 Page 12
- PICKED OR DROPPED BITS ON THE I/O BUS. Page 12

●MISCELLANEOUS

- CORPORATE DISTRIBUTION - LOSS AND RECOVERY TRANSIT DAMAGE. . Page 14
- DN6X SURVEY. Page 15

●SOFTWARE

- LP100 FILES. Page 17
- SYSERR REPORTS HEADER ERRORS INCORRECTLY Page 19

SEND ANY ARTICLES WHICH YOU FEEL SHOULD APPEAR IN GOOD STUFF TO:

GOOD STUFF EDITORIAL OFFICE
c/o NANCIE MITCHELL
MR1-1/S35
DTN: 231-5148
TWX CODE: MR11

ANY FIELD SERVICE EMPLOYEE (700 cost centers only) REQUESTING GOOD STUFF MUST SUBMIT A MEMO OR TWX TO:

SAME AS ABOVE

WITH THE FOLLOWING INFORMATION:

- NAME
- BADGE #
- COST CENTER
- LOCATION CODE

ABOUT THE COVER...

You may have noticed our cover has been changed to reflect the colors of our LCG Systems.

Hope you like it!

EDITORArt O'Donnell
 ASSOC. EDITOR...Nancie Mitchell
 EDITORIAL OFFICEMR1-1/S35

GOODSTUFF is published on a monthly-basis.

HOW TO DUMP THE CONTENTS OF A DCL'S REGISTERS

BY: SCOTT SITTERLY

IHFS - MARLBORO

There are times when it's nice to be able to get a dump of the registers in the DCL. One time that I've found it handy is when you have an unsafe condition. Though error registers two and three don't reflect all errors in a drive, they do reflect many of them.

The easiest way to do this is to start up the basic disk diagnostic for your drive (DFRPK,DDRPK,DFRPH,DDRPH), select your RH, now when it asks for what drive--type a "CONTROL C" (^C), "SP (CARRIAGE RETURN)". This will stop the diagnostic, and "DDT (CARRIAGE RETURN)". Now you should be in DDT with the diagnostic pointing to the correct RH10/20 and all his tables are set-up. Now you need to set-up what drive you want to test. Type "DRIVE/" and DDT will come back with the drive presently selected. You now type the drive number that you want to test (example "2") and a "CARRIAGE RETURN" and now location (drive) will equal the number of the drive that you want to test.

PUSHJ P,SNAPA\$X THIS TAKE A SNAPSHOT OF THE DCL & RH
PUSHJ P,DUMPA\$X THIS WILL DUMP THAT INFORMATION ON THE CTY

If you now want to restart the diagnostic, you type G\$G and it will ask you if you've reconfigured and if you say "NO" the diagnostic is off and running without any more questions or typeouts.

NOTE: SA\$G is a similar shortcut in DDRPI when in DDT.

Cross Reference: RP05/06-TT-27/RP04-TT-66

MODEM CONTROL DIAGNOSTICS (DZDHK) WON'T RUN ON A DC 20?

BY: EOB MC DWELL

EDUCATIONAL SERVICES - BEDFORD

If you have ever confronted (or suspected) a modem control problem on a DC 20, then no doubt you know that you cannot run DZDHK when loaded from disk under KLDCP.

Charlie Pugh and John Foley (F.S. Representatives) found that an Emulator Trap appears to be trying to get into an area in KLDCP. When the diagnostic is started, KLDCP is entered and takes control.

There are two ways that you can run the diagnostic (while we await a permanent fix): NOTE: This problem will be submitted to Software Engineering for fix.

1. CHANGING EMT LOCATION 30

The new PC for the emulator trap, at location 30, presently contains an address in the KLDCP area.

- A. Load but do not start DZDHK [> . P ZDHKDO <CR>]
- B. Change location 30 to 12770
- C. Load address 200
- D. Set swith 0 = "1"
- E. Start [DZDHK will start and ask for address and vector].

2. RUNNING DZDHK UNDER XXDP:

You will need two floppies: (1) DJYBA-J-YP, 2040 Front-End DEC/X11 Exerciser Cusp, containing RXDP and UPD2, and (2) DJYAB-M-YB, 2040 Front-End (11/40) CPU Diag Cusp #2, containing ZDHKDO.BIC, Model Control Diagnostic.

Place floppy containing RXDP in Drive 0 and floppy containing DZDHK in drive 1. Simultaneously depress ENABLE and FLOPPY. Refer to the following diaglog and enter the appropriate information listed under "OPERATOR ACTION:"

(After booting from FLOPPY 0)

SYSTEM:

RXDP - XXDP RX11/RX01 MONITOR M-11-DZQUJ-B 21-FEB-76 28K
RESTART ADDR:152260
TO ABORT THE FOLLOWING HELP MESSAGE TYPE CTRL C (^C)

MODEM CONTROL DIAGNOSTICS (DZDHK) WON'T RUN ON A DC 20?

TYPE:

F<CR> TO SET CONSOLE FILL COUNT
D<CR> FOR DIRECTORY ON CONSOLE, OR
D/F<CR> FOR SHORT DIRECTORY ON CONSOLE, OR
D/L<CR> FOR DIRECTORY ON LINE PRINTER, OR
D/L/F<CR> FOR SHORT DIRECTORY ON LINE PRINTER,
R COPY<CR> TO RUN COPY PROGRAM.
R FILENAME<CR> TO RUN ANY OTHER PROGRAM.
L FILENAME<CR> TO LOAD A PROGRAM ONLY
S<CR> TO START THE PROGRAM JUST LOADED,
S ADDR<CR> TO START THE PROGRAM AT SPECIFIC ADDRESS.
C FILENAME<CR> TO RUN A CHAIN,
C FILENAME/QV<CR> TO RUN A CHAIN IN QUICK VERIFY MODE.
REFER TO XXDP USER MANUAL MD-11-DZQXA FOR ADDITIONAL HELP.

OPERATORS ACTION: .R UPD2 <CR>

SYSTEM:

DZQUB-I 21-JUL-76 - XXDP UPDATE PROGRAM #2
DATE:

OPERATORS ACTION: (Type in the data according to the format:
Day-Month(Three letters)-Year).

7-May-79 <CR>

SYSTEM:

7-MAY-79
PROGRAM RELOCATED TO: 120764
RESTART: 125116

OPERATORS ACTION: *Load DX1:ZDHK0.BIC<CR>

SYSTEM:

XFER:000001 CORE:000000,017724

OPERATORS ACTION:

At the 11/40:
Load address 200
Set Switch 0 = "1"
Start (DZDHK will ask for address and vector.)

NOTE: IF YOU DON'T GIVE THE DIAGNOSTIC THE ADDRESS AND VECTOR IT WILL PROBABLY TRAP AND HALT, REFER TO THE DIAGNOSTIC LISTING IF THERE ARE ANY FURTHER QUESTIONS CONCERNING THE DIAGNOSTIC.

KLINIK/DGQDF INTERACTION

BY: RANDY WATSON

INFS - MR1-2

Recently, I discovered that the DN20 down line loader; DGQDF, requires that a KLINIK DL be installed and that the KLINIK must be at the correct address. The failure symptom is as follows:

- 1) DGQDF loads and starts okay.
- 2) After you answer the questions the program responds;

"DGQEA BEING LOADED"
"DGQEA BEING TRANSMITTED"
"?BUS TIMEOUT HALT AT 005126"

This happens because the program goes out to check the KLINIK status register and if the KLINIK DL11 is not there or is at the wrong address it causes a bus timeout. I checked with Diagnostic Engineering and they told me that this is because all KL-based systems are supposed to have a KLINIK DL installed even if it isn't used.

SO...if you get this failure, check to see if the KLINIK DL is installed and if it is be sure the address jumpers are cut for ADR.775610.

LP10 DROPPING READY
INTERMITTENTLY

BY: SCOTT SITTERLY
IHFS - MARLBORO

I recently troubleshot a problem on a 2470 Data Products line printer where the LPT would drop ready intermittently. The real problem turned out to be noise on the DC voltages (e.g.: +5 volts). I have seen the static eliminator give these symptoms, however, pulling the fuse for it didn't help.

The drum speed fault looked to be what was resetting ready, yet the drum speed looked to be okay.

The fix turned out to be the blower (fan) which cools the paper motion motor, causing noise throughout the LPT. The way I found it was when the problem became somewhat solid, I would pull out a fuse thus eliminating this blower from the circuitry and wait for a failure. When I pulled the fuse for this blower, the problem went away!

Cross-Reference: LP10-TT-8

TU45 LOAD PROBLEMS

BY: KEITH PARKER
IHFS

Here are a few good tips when troubleshooting TU45 load problems. I have found many times that adjustments are the source of the problem, therefore, here are things to look for:

SYMPTOM:

TU45 Loads loops correctly, but drop vacuum when searching for BOT, or tape drops vacuum while loading loops.

SOLUTION:

Check adjustments for TUS (take-up speed) and SUS (Supply speed). Also, verify that the supply reel hub is not turning loosely during tape motion. Adjust hub locknut, if necessary. If tape drops vacuum while loading loops, refer to troubleshooting section of TU45 Manual.

SYMPTOM:

TU45 stops load sequence before loading loops into columns.

SOLUTION:

Check adjustments for EOT and BOT.

These two quick checks can save you from spending alot of time verifying all the tape motion adjustments.

8-231

TGHA SOFTWARE FOR MOS MEMORY→ BY: GENE YONCHAK →
M.E.G. - MARLBORO

-6323

With the advent of the MOS memory system for the DECsystem-20 and 1091 families, there is some confusion regarding the software known as TGHA.

This software (The Great Heuristic Algorithm) currently is available only on the KLAD20 diagnostic media. In its current form, it was never intended to be available for customers' use on their individual systems, because of several lines of code that must be "patched" to the existing Release 3A monitor.

Many customers have been expecting this software for sometime, and because of this, several Field Service individuals have been "donating" this software to their customers from the KLAD20 diagnostic pack. This is a dangerous practice, since the use of the incorrect software could possibly result in damage to the customers file structure! We recognize that the TGHA software is late in coming, so the following steps are being taken to make TGHA Phase I (preliminary) available for MOS memory customers who are currently running Release 3A software.

1. A special tape is in the process of creation that contains TGHA.EXE and TGHA.HLP, and an auto-patch file that will insert the patches for Release 3A software. This tape will also contain reference information for the patches that must also be inserted in the DN20 for the IBM software (used if the customer is implementing 2780/3780 functionality).

2. Since all MOS memory systems are being carefully tracked, this tape will be AUTOMATICALLY distributed through software distribution, sometime around the end of July, or mid-August. Please do not call in orders.

3. TGHA.EXE and TGHA.HLP will be incorporated as a part of the standard release software for Release 4, when it is ready for distribution. The monitor will not require any patches.

SCOPING STC DRIVE SIGNALS AT THE CABLE

BY: SCOTT SITTERLY
IHFS - MARLBORO

This chart shows the pin layout of the controller end of the tape drive cable, as you're looking at the backplane of the controller. If you use this chart in conjunction with Table 1 on Page 9 of 46 of the Purchase Specifications (the next page) you'll be able to scope the signals going to and coming from a tape drive at the cable connector on the controller backplane. The last sheet is a copy of Figure 3-25 page 3-36 of the 3600E magnetic tape units maintenance manual which shows the tape drive end of the tape drive cable.

Cross Reference: TU70-TT-18.

01	02	03	04	05	06	07	08	09	10	11	12	13
					A1		A2					
						A3						
					A4		A5					
						A6						
	A7		A8		A9		B1		B2		B3	
B4		B5		B6		B7		B8		B9		C1
	C2		C3		C4		C5		C6		C7	
C8		C9		D1		D2		D3		D4		D5
	D6		D7		D8		D9		E1		E2	
E3		E4		E5		E6		E7		E8		E9
	F1		F2		F3		F4		F5		F6	
F7		F8		F9		G1		G2		G3		G4
	G5		G6		G7		G8		G9		H1	
H2		H3		H4				H5		H6		H7
	H8		H9						J1		J2	
J3		J4								J5		J6
	J7		J8						J9		K1	
K2		K3								K4		K5
	K6		K7						K8		K9	
L1		L2		L3				L4		L5		L6
	L7		L8		L9		M1		M2		M3	
M4		M5		M6		M7		M8		M9		N1
	N2		N3		N4		N5		N6		N7	
N8		N9		P1		P2		P3		P4		P5
	P6		P7		P8		P9		R1		R2	
R3		R4		R5		R6		R7		R8		R9
	S1		S2		S3		S4		S5		S6	
S7		S8		S9		T1		T2		T3		T4
	T5		T6		T7		T8		T9		V1	
						T8						
						V2						
						V3		V4				
							V6					
								V7				

TABLE 1
CONNECTOR POSITIONS

SIGNAL	SHIELD	NAME
B4	C8	GO
A7	C2	BACKWARD
E3	F7	SET WRITE
D6	F1	SET READ
E4	F8	SET NRZI
D7	F2	REWIND
H2	J3	REWIND UNLOAD
G5	H8	METERING OUT
G6	H9	STATUS 2
L1	K2	STATUS 3 (NOT USED)
L7	K6	SELECT
C1	D5	MOD 4
B3	C7	MOD 2
E9	G4	MOD 1
E2	F6	NRZI
E8	G3	SEVEN TRACK
E1	F5	READ STATUS
H7	J6	BACKWARD STATUS
H1	J2	NOT FILE PROTECTED
H6	J5	WRITE INHIBIT
G9	J1	LOAD POINT
N8	M4	NOT END-OF-TAPE
P6	N2	NOT READY
H3	J4	3600
V6	V3	WRITE BUS P
V7	V4	WRITE BUS 0
T6	S2	WRITE BUS 1
R5	S9	WRITE BUS 2
T7	S3	WRITE BUS 3
R6	T1	WRITE BUS 4
T8	S4	WRITE BUS 5
R7	T2	WRITE BUS 6
T9	S5	WRITE BUS 7
A1	A4	READ BUS P
A2	A5	READ BUS 0
A8	C3	READ BUS 1
D1	B6	READ BUS 2
A9	C4	READ BUS 3
D2	B7	READ BUS 4
B1	C5	READ BUS 5
D3	B8	READ BUS 6
B2	C6	READ BUS 7

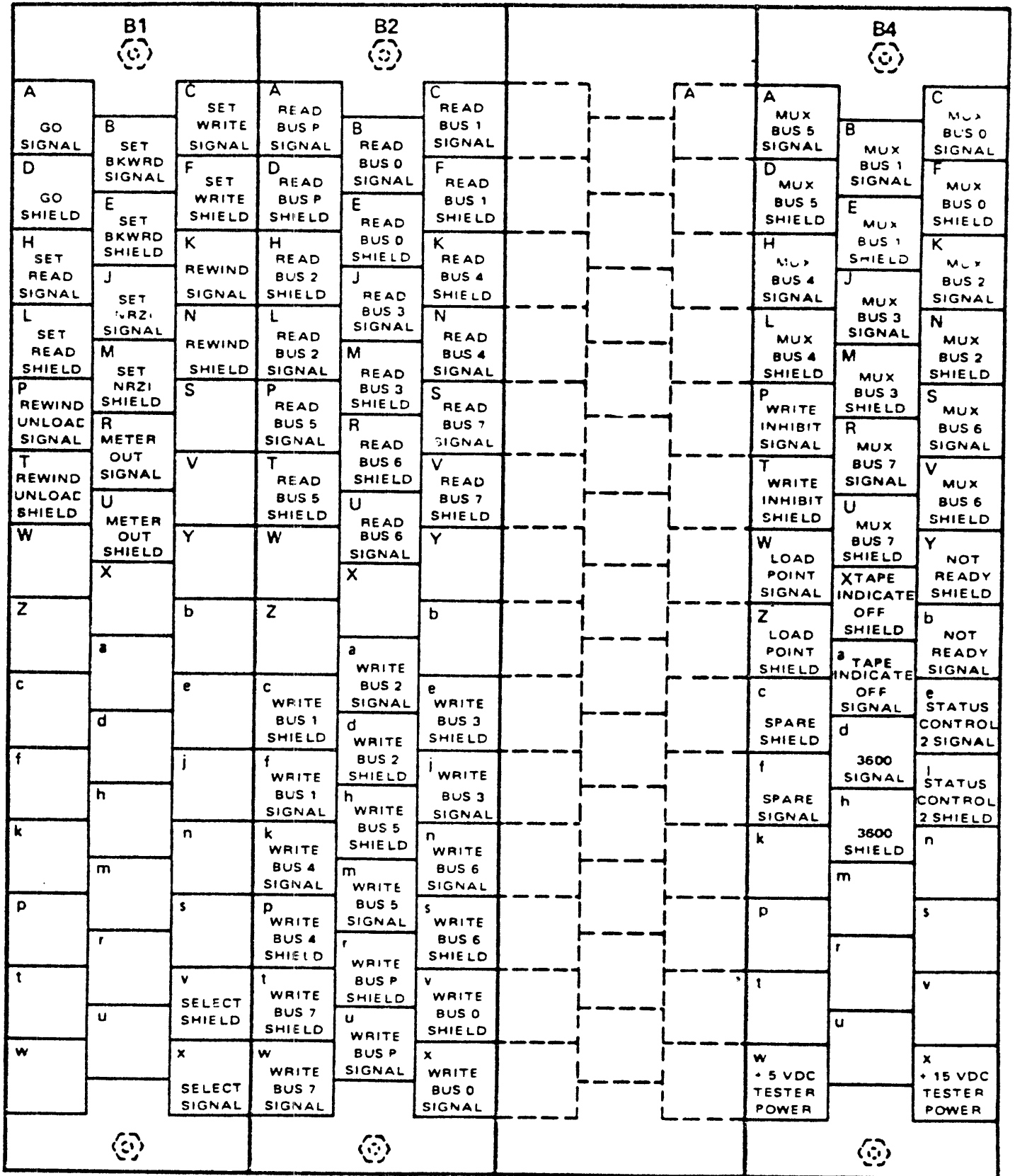

Figure 3-25. Tape Unit I/O Connector

2020 HALT STATUS BLOCK PROBLEM

BY: JOE HOLEWA/PETE MARTI
M.E.G.

There currently exists a halt-status block problem with all 2020 systems in the field (2020 system revision is irrelevant).

Neither TOPS10 nor TOPS20 (with current field-image 8080 code or current micro-code) transfer the halt-status block correctly. The halt-status block is changed by the "single instruction execute" the 8080 has to do to start preboot. Therefore, you do not get the halt-status block which was obtained at the time of the error whenever the 8080 has to boot after a crash.

When analyzing a monitor-dump after a crash you will not be able to get the valid halt-status block.

POTENTIAL SHORT CIRCUIT - TU72

BY: LARRY BURKE
LCG PRODUCT SUPPORT - MARLBORO

There is a possibility of a short circuit putting 208V on the frame of the TU72.

The problem occurs when the power wires supplying 208V to the reel motor cooling fan is not routed through the cable clamp mounted to the left of the fan assembly. This may allow the wires to rub against the metal clamp holding the cooling hose to the output of the cooling fan and cause a short to the frame.

Please inspect all TU72's for this condition and re-route the power harness to the fan, if necessary.

Cross Reference: TU72-TT-3

PICKED OR DROPPED BITS ON THE I/O BUS

BY: SCOTT SITTERLY
IHFS - MARLBORO

A one on the I/O bus is equal to a ground, a zero is equal to -3 volts. Usually, the failures are when the signal is grounded and therefore, you pick a bit. To determine if you are picking a bit, do a DATAI from a non-existent device and you should get all zeros back. If you get a bit back, this is your picked bit. If you get many but not all bits back, then you probably have a left and a right I/O bus swapped.

The following is an example of a DATAI KLDCP procedure:

DMO/O	Deposit 0 in AC 0
EMO	Check if AC 0
000000/000000 000000	is equal to 0
EX 777440000000	DATAI from device 774 (currently not used)
EMO	This shows bit 2 was
000000/100000 000000	picked

If you have a TD10, a good way of determining whether or not your dropping a bit on the I/O bus is to do a DATAO of all ones to the TD10, then do a DATAI back from the TD10 and see if you drop any bits.

PICKED OR DROPPED BITS ON THE I/O BUS (cont.)

The following is an example of A TD10 KLDCP procedure:

```
DMO/-1          Deposit ones in AC 0

EMO             Check if AC 0
000000/777777 777777  is equal to ones

EX 732140000000  DATA0 to TD10 all ones

DMO/0          Deposit 0 in AC 0

EMO             Check if AC 0
000000/000000 000000  is equal to 0

EX 732040000000  DATAI from TD10

EMO             This shows bit
000000/677777 777777  2 dropping
```

If you don't have a TD10, but do have an LP100, the LP100's leds will display bits 0-34 of a DATA0. The only bit you can't see is bit 35.

The following is an example of a LP100 KLDCP procedure:

```
DMO/-1          Deposit ones to AC 0

EMO             Check if AC 0
000000/777777 777777  is equal to ones

EX 712540000000  DATA0 to LP100 of ones if device = 124
```

Now you have to look at the LP100 lights labeled "Line printer buffer" and see if you've dropped a bit. In this case if your dropping bit 35 your out-of-luck. Plus, you should check to see if all your lights work, by putting all data switches up and while in off-line, single step until you've filled the buffer.

Cross-Reference: KL10-TT-69

CORPORATE DISTRIBUTION - LOSS AND RECOVERY
TRANSIT DAMAGE

BY: FRANK ASCOLILLO
NR1-2

We have recently received criticism from customers regarding responsibility for equipment damaged in transit. After such a loss has occurred, customers suddenly become aware of their responsibility to pay for the damaged equipment since most of our sales are made FOB (Freight on Board) origin. If the shipment was properly insured in accordance with the Digital Transit Insurance available to our customers, the customer would incur no financial loss. If the customer has declined in writing to purchase the insurance, the responsibility to pay for the lost or damaged equipment rests with the customer. Practically speaking, a customer will be very reluctant to pay thousands of dollars for a piece of equipment which was never received. The usual ploy is to say to Digital, "since I have no insurance to cover the loss, you must either absorb that loss or risk losing my future business." At that point, the product line must decide whether to pursue the customer for the unpaid balance and risk losing the customer or else absorb the loss.

The customer can go after the carrier, but the law generally limits the carrier's liability to between \$0.50 and \$9.07 per pound, regardless of the value of the unit. In some cases, a unit weighing 1000 pounds with a value of \$150,000 results in the trucker paying the customer \$5,000. The \$145,000 damages must be borne by the customer.

It is in Digital's interest to educate our customers about the availability of Digital Transit Insurance. All shipments must be insured under the Transit Insurance program unless Digital has received from the customer a clear, written statement specifically rejecting the coverage. Any doubts as to the intentions of the insurer should be resolved in favor of insuring the shipments because, in the event of loss, the customer will almost always insist that they would have purchased the insurance if Digital had educated them as to the benefits of the insurance coverage. Reference the Contracts article entitled, "New Corporate Discount Agreements" in Sales Update - Vol. 10 #22 for In-Transit Insurance Information.

CORPORATE DISTRIBUTION - LOSS AND RECOVERY TRANSIT DAMAGESALES AID

A pamphlet has been made available through the Corporate Insurance Department outlining the benefits available from this very special service provided by Digital. Any questions concerning availability or coverages can be addressed to Ron Lamb (MS/F20 DTN 223-5440).

CLAIMS

The Loss and Recovery Department has been established in Northboro to handle any claims arising from the distribution process to the actual installation site. In the event of damage to equipment insured under this program, call the Loss and Recovery Department, (617) 393-6781, ext. 501 or 507 to register a claim, and seek authorization for no charge repairs or replacement. In this way, your customers will be back in operation as quickly as possible.

NOTE: This article originally appeared in Sales Update - Vol. 10 #22

DN6X SURVEY

BY: CATHY FENCE
SOFTWARE SUPPORT

Software Support (Networks and Communications) is attempting to gather information about installations that have DN6X's. We wish to build up a library of documentation on the different RJE stations and operating systems we interface to. To do this, it is necessary for us to know what configurations exist. This way we can find what systems and hardware need documentation and also provide those in the field with the answer to those time-honored questions:

- Is anybody else doing this?
- Has anybody else had this problem?

It would help if those of you in the field would answer these questions about systems you have running DN6X software. Please return this information to:

Networks and Communications
Support Group
MR1-2/H22
c/o Cathy Fence

DN6X SURVEY

1. Who is the customer? _____
2. What is the general hardware configuration?
(1090,1091,2020,2040,etc.)

3. What monitor is being used? (3,3A,4,6.03,6.03A)

4. Which DN6X Software are you running?
(DN61B,DN61D,DN61S,DN64A)

5. What port(s) is/are the DN20/DN87 on? (DTE# and/or DL10#)

6. EMULATION OR TERMINATION? (OR BOTH)

7. 2780, 3780, or HASP? (For those who are field-testing Release 4)

8. What modems are you using? (Manufacturer, compatible to what,
baud rate).

9. Are you interfacing to a private data network?

10. What is on the other of the line?
Termination - DATA100 (what model, what peripherals)
 DN200
 Other Manufacturer (What hardware, what software,
 who are they emulating?)

Emulation - IBM System (Specific operating system)
 Other (What Software, who are they
 emulating?)
11. Do they intend to upgrade to HASP multileaving?

FROM: _____
LOCATION: _____

PHONE: _____

***** RETURN THIS INFORMATION TO: *****
CATHY BENCE - MR1-2/H22

LP100 FILES

BY: KENNETH P. YOUNG
SOFTWARE SERVICE - MARLBORO

Attached, please find patches which will fix all known LP100 problems:

[SYMPTOM]

IME or garbage output when printing on an LP100.

[DIAGNOSIS]

LP100 raises DONE when turned back on line. If no errors up, we continue printing. ADVBFE steps to a garbage buffer or IME if job is swapped.

[CURE]

Stop printer if IOACT is off.

[FILCOM]

```
.EDIT 8396 ;FCR 6.03A
.DATE 16-MAR-79
.MODULE LPTSER
.INSERT LPTRE2+11,REPLACE,<PUSHJ P,LPTOFF>

      TRZ      S,IOACT      ;CLEAR ACTIVE I/O

.ENDI
.INSERT LPTINT+1,BEFORE,<XCT LPTDNZ##(F)>

      HRL      F,DEVIOS(F)
      TLNN     F,IOACT
      JRST     LPTSVE##(F)

.ENDI
.INSERT LPTNXT+2,AFTER,<JRST LPTERR>

      TRNN     S,IOACT
      JRST     LPTSTP

.ENDI
. ENDE
```

[SYMPTOM]

1. Reprinted buffers (BA10,LP100).
2. LOST characters (LP100 only).

[DIAGNOSIS]

1. If printer goes OFF-LINE after exhausting ELKO pointer, we forget to advance buffer.
2. LP100 says on-line while BUSY is still set.

[CURE]

1. ADUBFE if LPTOPB is set and LPTPTR > or = 0 (but not if LPTSYN or IOBEG).
2. Declare printer OFF-LINE if BUSY is set.

[FILCOM]

```
.EDIT 8486                ;FOR 6.03A
.DATE 16-MAR-79
.MODULE LPTSER

.INSERT LPTPZR-2,REPLACE:2,<TDZ U,[-1,,CO.PIA+CO.PIB]>

      JRST  LPTRTI  ;CLEAR INTERRUPT AND DISMISS

.ENDI
.INSERT LPTSET+4,AFTER,<SKIPL  T2,LPTPTR##(F)>
      JRST  [TLNE  S,IOBEG!LPTSYN  ;TROUBLE ON FREE FORM FEED?
             AOJA  T1,LPTS1        ;YES, CONTINUE WITH USERS BUFFER
             PUSHJ P,ADVBFE##      ;NO, GET NEXT BUFFER
             JRST  LPTSTP          ;NONE, STOP
             JRST  LPTSET]         ;PRINT NEW BUFFER
```

```
.ENDI
.INSERT LPTONL+1,REPLACE,<TRNE U,CI.NRY>

      TRNE    U,CI.NRY!CI.OFL!CI.BSY ;IS IT OFFLINE?

.ENDI
.INSERT LPTONL+5,REPLACE,<TRNN U,CI.VFE!CI.OFL>

      TRNN    U,CI.VFE

.ENDI
.INSERT LPTOFF-1,REPLACE,<TRZA U,CI.BSY+CI.DON+CI.NRY+CI.CHR>

      TRZA    U,CI.DON+CI.NRY+CI.CHR

.ENDI
. ENDE
```

SYSERR REPORTS HEADER ERRORS

I N C O R R E C T L Y

BY: LES MC CONNELL

LCG MFG. ENG.

Under TOPS10, SYSERR reports cylinder, surface, and sector as a function of the logical block number (LBN). When a disk is experiencing header errors (HCRC or HCE) this information can be erroneous because you can't believe the LBN which was read. A detailed SYSERR (/DETAIL SWITCH) report must be obtained to determine what the DCL registers contained. The real surface and sector where the error occurred can be read from the Desired Address Register (05), while the true cylinder can be found from Desired and Current Cylinder Registers (12 and 13).

This discrepancy will be resolved with release 700 of TOPS10.

STUFF

COMPANY CONFIDENTIAL

This document contains sensitive information which shall not be disclosed to personnel outside of Digital Equipment Corporation.

This Newsletter is meant as an information document. Its contents are not necessarily Company Policy. It's a means by which LCG Product Support can distribute some tidbits of information to you.

IN THIS ISSUE...

● DIAGNOSTICS

- ● DDRPI MUJO FAILURES ON KL10PV WITH RH10 (EXEC MODE) Page 3

● HARDWARE

- ● CRASH FILE FOR 2020. Page 4
- ● DRUM PRINTER RIBBON MOTOR. Page 5
- ● RP06 SKI ERRORS. Page 6
- ● TU45 REEL MOTOR. Page 6
- ● MISTAKES IN THE KS10 AA-AB PRINT SET (MP00540) Page 7

● MISCELLANEOUS

- ● KS10 MAINTENANCE GUIDES. Page 9
- ● REVISION CONTROL Page 10
- ● INSTALLATION PROCEDURES. Page 10

● SOFTWARE

- ● TIMING PROBLEM WITH TM10 TAPE SUBSYSTEMS Page 11
- ● TOPS20 (RELEASE 4) DH-11 LINE TERMINATION. Page 12
- ● FIELD INPUT NEEDED/RSX20F. Page 13
- ● 7.00 AND DUAL-PORT DISKS Page 13

SEND ANY ARTICLES WHICH YOU FEEL SHOULD APPEAR IN GOOD STUFF
TO:

GOOD STUFF EDITORIAL OFFICE
c/o NANCIE MITCHELL
MR1-1/S35
DTN: 231-5148
TWX CODE: MR11

ANY FIELD SERVICE EMPLOYEE (700 cost centers only)
REQUESTING GOOD STUFF MUST SUBMIT A MEMO OR TWX TO:

SAME AS ABOVE

WITH THE FOLLOWING INFORMATION:

- NAME
- BADGE #
- COST CENTER
- LOCATION CODE

EDITORArt O'Donnell
ASSOC. EDITOR..Nancie Mitchell
EDITORIAL OFFICE.... MR1-1/S35

GOOD STUFF is published on a
monthly-basis.

DDRPI MUUO FAILURES ON KL10PV WITH RH10 (EXEC MODE)

BY: P.CLARK/R.HARKINS/C.KRETZ
 IN-HOUSE FIELD SERVICE - MAYNARD

We have found the DDRPI will not run on KL10PV (MODEL B) based systems on the RH10 subsystem. The diagnostic constantly gets MUUO ERRORS and PAGE FAIL TRAP ERRORS. We have called the diagnostic hotline in Marlboro and have been informed that the diagnostic fails due to incorrect handling of the vectored interrupt. The feeling in Diagnostic Engineering is that the problem is caused by the KL10PV microcode and therefore requires no further action on their part. We were also informed that the feeling at the Microcode Engineering level is that no action is required because few systems exist with RH10 controllers on "MODEL B" machines.

Evidently, the reason that the diagnostic fails is that the KL10PV microcode returns the wrong section number during vectored interrupt processing. An interim patch was given to us which inhibits the diagnostic from doing vectored interrupts. We have verified that the patch works for both DDRPI VERSION 4 and DDRPI VERSION 6.

THE PATCH IS:

<u>LOCATION</u>	<u>ACTUAL</u>	<u>CHANGE IT TO</u>
ISETV:	SECTOM VECTOR	SETZM VECTOR

FOR VERSION 4 THIS BECOMES:

```
>.EM 37577 ;EXAMINE LOCATION "ISETV"
37577/476000 077152 ;YES IT IS THE SETOM
>.DM 37577/402000 077152 ;MAKE IT THE SETZM
```

FOR VERSION 6 IT TRANSLATES TO:

```
>.EM37702 ;EXAMINE LOCATION "ISETV"
37702/476000 077322 ;YES THIS IS THE SETOM
>.DM37702/402000 077322 ;CHANGE IT TO THE SETZM
```

NOTE: Have submitted this problem to Diagnostic Engineering for further action.

CRASH FILE FOR 2020

BY: BOB BARR

REGIONAL SUPPORT - KANATA

Below, please find my proposed crash file for 2020. It should provide enough information to correct most problems.

All information and references can be found in KS REF.

20 CRASH FILE

This file is to be used on any hung or halted system.

^ \ (Control Backslash)	Enter KS mode
CH,TEO,TPO	Halt clock, disable traps and timer.
EI	What register is in use?
EC	Examine current ucode address.
EB	Examine the KS Bus.
SM1	Save status block.
ECO	Reset ucode to 0
CS	Start the clock.
CH	Halt the clock.
EC	In the halt loop?
EM17	Can you examine memory?
EX 700000 17,EM 17	APRID, OPTIONS,SERIALS
EX 700240 17,EM 17	Read APR.
EX 701040 17,EM 17	Read UBR.
EX 701240 17,EM 17	Read EBR.
EI 1763100	Read UBA#1 Status Reg.
EI 3763100	Read UBA#3 Status Reg.
EI 100000	Read Memory Status Reg.

DRUM PRINTER RIBBON MOTOR

BY: BERT LONGO

M.E.G.

The ribbon motor used in the DataProducts Drum (LP05, LP06, and LP14) printers has been enhanced to improve its' life expectancy.

Your help is needed in verifying the actual field performance of both old and new motors. Please supply, via AIDS Report or memo (see address below), pertinent life data and your personal observations of the motors, specifying:

- Old or New Motor
- DpC P/N
- Motor Manufacturer P/N

The following chart is presented to aid you in the identification of the motors.

DEC NO.	DpC P/N	MOTOR P/N	COMMENTS
29-21120-00	810002-001	131021B486	NEW - FRU
29-21120-01	801128-001	13102B459	OLD

Thanks in advance for your cooperation.

SEND INFORMATION TO:

Digital Equipment Corporation
200 Forest Street
Marlboro, MA 01752
Attn.: Bert Longo - MR1-1/S35

RP06 SKI ERRORS
BY: GEORGE KONDOS
DDC/LCG

If you are having intermittent and apparently random cylinder seek incomplete (SKI) errors on your RP06, check to see whether the tach rod is loose. This could be the cause of the problem, but be careful if you try to tighten it. It can be tightened from the back with a pair of needle nose pliers (although this is not recommended), but if you turn just a bit too hard it will break off.

To properly tighten the tach rod, it is necessary to have a head separator tool and a 1/4-inch open-end wrench. The procedure is given on page 4-32 of the RP06 MEMOREX Manual. If you have these tools available, do not try tightening the tach rod with the pliers as that is only an emergency method.

TU45 REEL MOTOR

BY: C. LOANE
F.S. - READING ENGLAND

It has recently been found that the elusive "TU45 Loss of Vacuum" syndrome can be caused by bad reel servo motors. On a site with three (3) TU45 systems, two units had 'ELECTRO-CRAFT' reel motors while the third had 'AMETEK' motors. All three units registered similar usage on the hour meters, but the units with Electro-craft motors gave intermittent vacuum loss.

On stripping one of these motors down, it was found that its brushes have an initial soft carbon construction at the tip. About half-way up the brush there seems to be a hard metallic plate embedded in the brush material (presumably the brush contact is bonded to this internally). On both faulty drives, the brushes had worn down to this metallic core, and, with all the servo motion this had caused excessive friction with the armature causing distortion of the brush holder assembly.

It's quite easy to check this by pulling off one of the reel servo motor leads from the G1 supply board and rocking the spindle to and fro. On a good motor, little or no noise is heard, while on a bad one, excessive ticking from the brushes is evident.

Changing the motors cleared the problem.

NOTE: This information has been submitted to CSS - Nashua for Tech Tip publication - TU45.

MISTAKES IN THE KS10 AA-AB PRINT SET (MP00540)

BY: JOE HOLEWA

M.E.G.

The following mistakes have been found in the KS10 print set:

- The first mistake is on sheet 23 of 31 of the KS10 processor unit assy. The state for W18 on the M7295 is wrong. The prints refer to W18 as being "OUT" for both disk and tape. The correct state is "IN" for both the disk and tape (NPR latency).
- The second problem is located on the M8616 (CSL) prints. On circuit schematic CSL2 the address, data, and enable lines are incorrect for the four (4) Intel 2716 (PROM) chips. Refer to the corrected circuit schematic included with this article (next page) to make corrections to your print set.
- The last problem pertains to the baud rate switch settings for the CTY and KLINIK ports on the M8616 (CSL) module. On CSL2 and CSL9 (REV B) the switch settings for 300 baud are wrong. Switch #4 is said to be "ON" when it must be "OFF". This problem has been corrected on the CSL2 and CSL9 (REV C) prints.

NOTE: These prints will be upgraded.

PRINT ON FOLLOWING PAGE



COMPANY CONFIDENTIAL

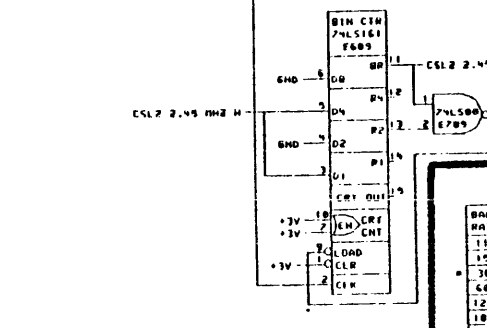
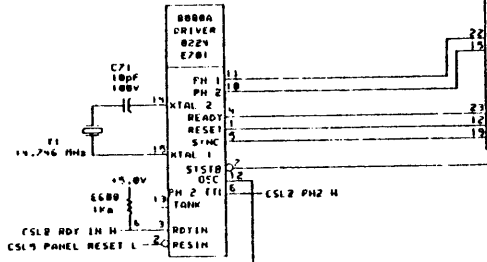
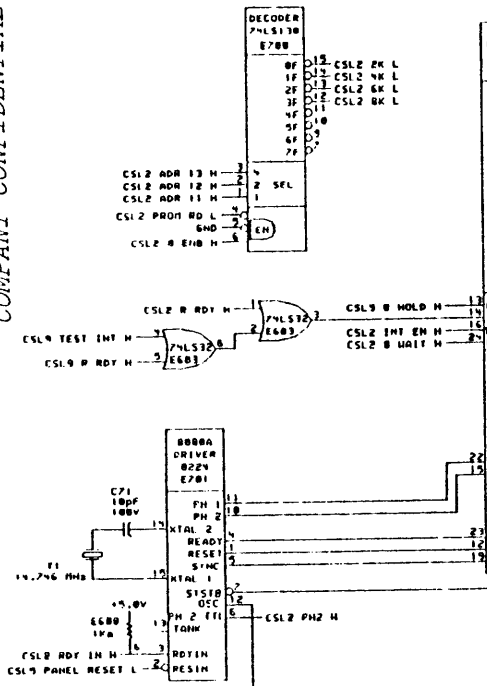
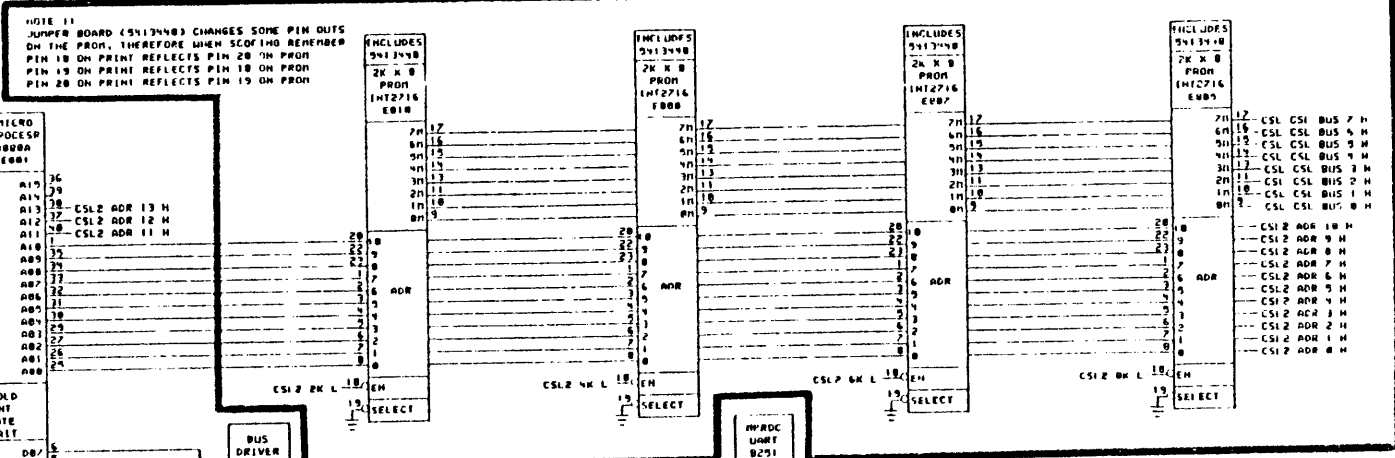

CONSOLE TERMINAL

BAUD RATE	E500 B1	E500 B2	E500 B3	E500 B4	E500 B5	E500 B6
110	OFF	OFF	OFF	OFF	OFF	OFF
150	OFF	OFF	OFF	OFF	OFF	OFF
300	OFF	OFF	OFF	OFF	OFF	OFF
600	ON	OFF	OFF	OFF	OFF	OFF
1200	OFF	ON	OFF	OFF	OFF	OFF
1800	OFF	ON	OFF	OFF	OFF	OFF
2400	OFF	OFF	ON	OFF	OFF	OFF
4800	OFF	ON	ON	OFF	OFF	OFF
9600	OFF	ON	ON	ON	OFF	OFF
3600	OFF	ON	ON	ON	ON	OFF

* NORMAL FACTORY SETTING
** SWITCHES B1 & B6 ARE SHOWN ON CS1A

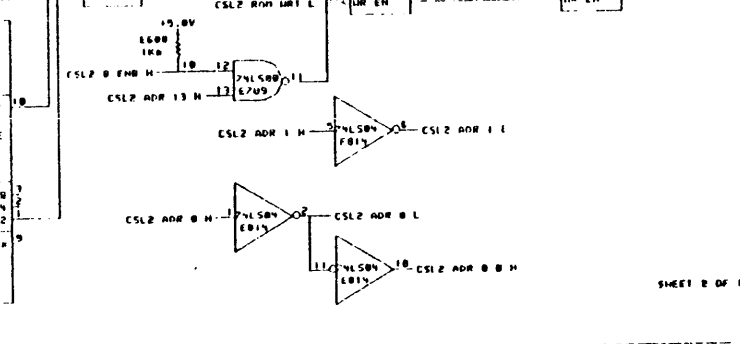
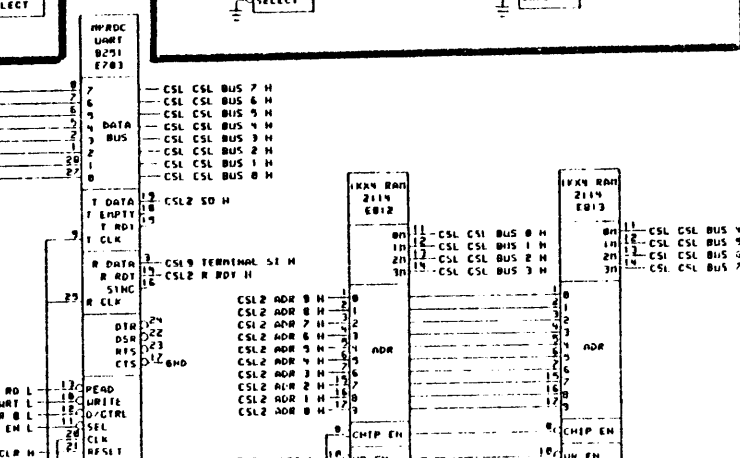
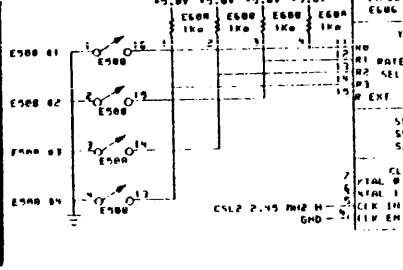

KS10 MAINTENANCE GUIDES

BY: LOU NAY
 LCG PRODUCT SUPPORT

KS10 Maintenance Guides (Vol. I) are now available from the Printing and Circulation Services Center - Northboro, Massachusetts.

This guide, like the KL10 Maintenance Guide will be limited to one copy per person and further limited to the following cost centers:

- All 700 series Cost Centers.
- All 800 series Cost Centers.
- All 35* Cost Centers. (* = alpha character)
- Cost Centers 3FA and 67C

There will be a subscription list maintained for subsequent updates of this Maintenance Guide.

To order a copy, do one of the following:

1. Have your Literature Contact order this guide via the Publications and Communications Services Request order form.
2. Order via TWX (CMS Code: NR12) - see below.
3. Order via memo (Printing and Circulation Services - NR2-2/M15) - see below.

Twx and memo orders should use the following format:

DATE: XX/XX/XX
 TO: Printing and Circulation Services - NR2-2/M15
 FROM: Name, Badge No., Location
 COST CENTER: Cost Center
 DATE REQUIRED: Real—not as soon as possible.
 SHIP TO: If different than the Requestor.
 INCLUDE: Your Name, Badge #, CC, and Location

<u>ITEM NO.</u>	<u>QUANTITY</u>	<u>PART NUMBER</u>	<u>DESCRIPTION</u>
1.	1	EK-OKS10-MG	KS10 MAINT. GUIDE

ALL orders must include the subscribers: Name, Badge No., Cost Center, and Location.

REVISION CONTROL

BY: DOUG DICKERSON
DDC/LCG

During a recent support trip, an intermittent channel failure was found to be an out-of-rev. M8536 module. The module was okay for a Model "A", but didn't work in this Model "B" processor. Several other boards were also found to be out-of-rev. Complicating factors were the lack of an up-to-date LCREV in the on-site microfiche library and the fact that the CPU was a factory upgrade to Model "B" and the exact revision and ECO status of the machine was unknown.

SOME SUGGESTIONS:

1. An up-to-date fiche library is essential. If your fiche library is missing what you need at 3:00 a.m. on a Sunday morning, the DDC has the latest documentation available 24-hours a day, seven days a week.
2. Out of revision modules can buy you unnecessary grief. Consider checking your machine against LCREV next P.M. On intermittents, especially if any modules have been replaced lately, consider checking revision levels first. Also, certain modules at certain revision levels are no good. An example is the M8554 Rev. "E".
3. If you install a KL10 system, save a copy of the revision level and ECO status information and include it in the Site Guide. It could save you or someone else who's working on your site lots of time.

NOTE: Reference Supplement included with this Issue - Titled KL10 REVISION CONTROL AND COMPATIBILITY.

INSTALLATION PROCEDURES

BY: RON MINEZZI
PRODUCT SAFETY

FIELD PERSONNEL ON OCCASION ARE ENTERING POWER SERVICE PANELS TO ATTACH METERING EQUIPMENT

DEC personnel must never enter any power service equipment. To do so is a violation of legal code, and is hazardous to untrained personnel. Installation of metering equipment or any other required functions within the power service equipment must be done by or under the direction of qualified electricians.

DEC's only function in conjunction with a power service, is to attach pluggable equipment. Our responsibility stops at the end of the power cord. Hard wired equipment or alterations to power receptacles must always be done by a qualified electrician.

For proper direction on the installation of equipment, refer to Site Prep Manual - EK-OCORP-SP-002. EK-OCORP-SP-002 will soon be superseded by EK-OCORP-SP-003.

Failure to observe these precautions could result in extreme personal injury or power loss to critical operations. It should also be noted that DEC's insurance may not cover consequential damages resulting from such incidents.

NOTE: Any questions or problems regarding the above information please contact Ron Minezzi - PK3-2/H10 - ext. 223-3122.

TIMING PROBLEM WITH TM10 TAPE SUBSYSTEMS

BY: IRA MACHEFSKY
SOFTWARE SUPPORT

It has recently come to our attention that there is a timing problem at certain sites with TM-10 or TM-10B controllers running version 6.03A of TOPS-10.

This problem has been reported by only two-sites thus far and manifests itself in random and spurious tape checksum errors and incorrect block length errors when running BACKUP. The tapes are actually written correctly, but read incorrectly. If tapes written under 6.03A exhibit these symptoms when read under 6.03A but not when read under 6.03, you probably have this timing problem. Although we have not been able to determine what, if any, hardware differences there are in the controllers that exhibit this problem, we have found that bringing the tape drives rigorously into spec can ameliorate the problem. Failing that, the following patch can be installed to 6.03A. However, the patch should be inserted only as a last resort as it can slowly down tape-to-tape I/O by as much as 25 percent. Disk-to-tape I/O should not be affected. Please also bear in mind that real hardware problems can cause the same symptoms.

The patch, which is not an MCO but does have the complete approval of Software Engineering, follows in MAKLIB format:

```
.EDIT 27909 ;SPR NUMBER, NO MCO NUMBER

.MODULE TMXKON

.INSERT CHRCT3+1,BEFORE,<PJRST TPOPJ##>,
      HLLZS      TKBSTS(W)

.ENDI

.ENDE
```

TOPS20 (RELEASE 4)
DH-11 LINE TERMINATION
BY: ROLAND BELANGER
LCG COMM NETWORKS - MR1-2/E89

There is a change in the Release 4 DH-11 Input Service which can cause problems with lines which are longer than EIA specifications will allow. The probability of these problems, which manifest themselves as a "hung" Front-End, increases with longer lines and higher terminal speeds.

The exact nature of the problem is that long, high-speed lines can oscillate or "ring" because of an improper line impedance.

The RSX20F/Release 4 Front-End saw the DH-11 Silo Alarm level set to 0, in order to process XOFFS as expeditiously as possible. Release 3A has the DH-11 Silo alarm level set at 32-characters. This change essentially causes the DH-11 input service to be a single-character processor.

Should one or more high-speed line (2400 baud, or higher) begin to oscillate, the Front-End can end up in an interrupt loop, and thus appear to be "hung".

Note that this situation can be exacerbated by SENDALLS and TOPS-20 sending BELLS in response to unrecognized characters.

It is, therefore, critical that the length of DH-11 lines are maintained within EIA specification and/or properly terminated for Release 4 and beyond.

While this phenomenon has not been observed during in-house load-test, we have received a QAR from a field-test site describing this problem.

FIELD INPUT NEEDED/RXS20F

BY: STEVE LEAPLINE
M.E.G. - MARLBORO

As most of you probably know, a great deal of work is being done to RSX20F to improve maintainability, reliability, and error detectability. So, to ensure that these changes are indeed helpful and not harmful, I have been given the task of inserting faults into the Hardware and RSX20F Software. To do this, I need some input from people who use RSX20F as a tool for maintenance, but find it either undesirable or unreliable.

If you could please take a minute and fill out a Fault Insertion Request sheet, (see next page), or call me and explain what kinds of problems your having, I would appreciate it. Below, please find my address and/or DTN number:

Steve Leapline
Digital Equipment Corporation
200 Forest Street
Marlboro, MA 01752

c/o MR1-1/S35
617-481-9511 X5016
DTN: 231-5016

7.00 AND DUAL-PORT DISKS

BY: TED WOJCIK
M.E.G. - MARLBORO

With the Release of 7.00 and the advent of dual-port disks something which was once widely ignored becomes very important.

What I am referring to are serial number jumpers. If your drives are all Serial # 0, you will have some problems trying to run 7.00 or later monitors. The serial numbers must be jumpered and all drives must have different serial numbers. If you do not heed this advice, all you will ever do is try to run 7.00, because, it will never run on a system with more than one drive with a given serial number.

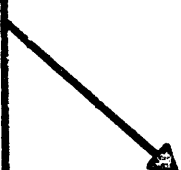

FAULT INSERTION SHEET
ON NEXT PAGE ---

FAULT INSERTION TEST REQUEST

DEVICE: _____

SOFTWARE COMPONENT: _____

I. DESCRIBE, AS BRIEFLY AS POSSIBLE, THE FAULT TO BE SIMULATED.

II. DESCRIBE WHY YOU FEEL THIS FAULT SHOULD BE TESTED.

III. ANSWER THE FOLLOWING QUESTIONS (IF POSSIBLE).

USE THE REVERSE SIDE, IF NECESSARY.

1. POTENTIAL CAUSES? _____

2. WHAT CURRENTLY HAPPENS WHEN THE FAULT OCCURS? _____

3. WHAT DO YOU THINK SHOULD HAPPEN? _____

4. CAN YOU SUGGEST A WAY TO CAUSE OR SIMULATE THE FAULT?

FROM: _____

ADDRESS: _____

PHONE: _____

DATE: _____

DO NOT WRITE IN THIS SPACE

DATE RECEIVED: _____

BY: _____

TROUBLESHOOTING AIDS AND RESOURCES

BY: BILL HILLIARD
LCG PRODUCT SUPPORT - MARLBORO

As part of the KL10 Service Enhancement Project, the following outline of troubleshooting aids and resources has been compiled. Along with each aid/resource is a description of how and when to use it.

I. TECHNICAL ASSISTANCE CENTER, MARLBORO (DEC10/20)

A. Phone Numbers/Location:

1. Telephone: 617-481-9511 X6903/6904
2. DTN: 231-6903
3. MR1-1/S35

B. Hours of Operation:

1. The DEC10/DEC20 TAC Center is manned between 8:15 a.m. and 8:00 p.m. - Monday through Friday. Outside of these hours, you may leave a recorded message.

C. Services Provided:

1. The Marlboro TAC Center will attempt to help you solve any service problem you may have. Among the many areas in which help will be provided are--ECO/FCO Information, Troubleshooting Assistance, Configuration Information and Assistance, Part Numbers, CLD Requests, Cabling, Conversion, Diagnostic Assistance, MCO Environmental Information, Installation Assistance Prints, Sales Information, Software Assistance, Specifications, Wire Run, and Tech Tips.

TROUBLESHOOTING AIDS AND RESOURCES (cont.)

II. TECHNICAL ASSISTANCE CENTER, MAYNARD (PDP8/11)

A. Phone Numbers/Location:

1. Telephone: 617-897-5111 X5901
2. DTN: 223-5901
3. PK3

B. Hours of Operation:

1. The PDP8, PDP11 TAC Center is manned from 8:15 a.m. to 8:00 p.m. - Monday through Friday.

C. Services Provided:

1. The Maynard TAC Center provides PDP8/11 service which is similar to Marlboro's TAC. they too will help you solve any service problem you may have.

III. DIAGNOSTIC HOTLINE

A. Phone Numbers/Location:

1. Telephone: 617-481-9511 X6556
2. DTN: 231-6556
3. Location: Marlboro

B. Hours of Operation:

1. The Diagnostic Hotline is manned from 8:15 a.m. to 5:00 p.m. - Monday through Friday. There is also a message recording service for after-hours use.

C. Services Provided:

1. As the name implies, the Diagnostic Hotline is there to help answer questions you may have about any diagnostic (or guide you to someone who can help). When calling the Diagnostic Hotline, be prepared to provide as much information about the operating environment as possible. This may include the device, the program, the system configuration, program version number, microcode version, SUBRTN version, etc.

TROUBLESHOOTING AIDS AND RESOURCES (cont.)

IV. SOFTWARE HOTLINE - MARLBORO

A. Phone Numbers/Location:

1. Telephone: 617-481-9511 X6492
2. DTN: 231-6492
3. Marlboro

B. Hours of Operation:

1. The Marlboro Hotline is manned from 7:30 a.m. to 5:00 p.m. - Monday through Friday.

C. Services Provided:

1. The Marlboro Software Support Group provides service on 17 software products, including; TOPS-10, TOPS-20, and their sub-components.
2. They also have a Communications Group to handle communications and network problems. In addition, you may also get information on SPR status and the CYRUS database.

V. SOFTWARE HOTLINE - MAYNARD

A. Phone Numbers/Location:

1. Telephone: 617-897-5111 X5911
2. DTN: 223-5911
3. Maynard

B. Hours of Operation:

1. The Maynard Hotline is manned from 8:15 a.m. to 5:00 p.m. - Monday through Friday. There is a message recording service provided outside those hours.

C. Services Provided:

1. The Maynard Software Support Group provides service on PDP8 and PDP11 software products except for the following:

- RSTS
- RSX11-M
- Lab Products

2. These three products will be serviced out of NORAM Regional Support Offices.

TROUBLESHOOTING AIDS AND RESOURCES (cont.)

VI. DIGITAL DIAGNOSIS CENTER (DDC) - COLORADO SPRINGS

A. Phone Numbers:

1. Telephone: 800-525-6570 (CUSTOMER USE ONLY)
303-599-4000 {FOR DEC FS TO LOG A
{CALL.
2. DTN: 522-4111, OPERATOR (ANYTHING EXCEPT
522-XXXX, KNOWN EXT.(LOGGING A CALL
522-2728, LCG GROUP

B. Hours of Operation:

1. The DDC is open seven-days a week, 24-hours a day, including holidays.

C. Services Provided:

1. At this time, the primary responsibility of the DDC is to provide the initial response to calls logged directly by our customers. They will attempt to lend assistance to DEC Field Service personnel if resources are available. The DDC remains dedicated to all products with remote diagnosis capability.

TROUBLESHOOTING AIDS AND RESOURCES (cont.)

VII. DOCUMENTATION CONTROL DISTRIBUTION (MICROFICHE)

A. Phone Numbers/Location:

1. Telephone: 617-275-5000
 - a. CONTACTS
 - Anne Guerra X2019
 - Marvin Rothberg, Manager X2001
 - Bob Kruger, Documentation Control Supervisor X2001
 - Bob Walker, Micropublishing Supervisor X2002
2. DTN: 249-XXXX (KNOWN EXT.)
3. Location: Bedford - BU/D2

B. Services Provided:

Contact this department is you wish to:

1. Direct your comments on distribution
2. Send requests for:
 - a. Missing Updates
 - b. Individual Fiche
 - c. Speed Bulletins
 - d. New Libraries - MINI, VAX, LCG, (KI, KL) KS10, New Product Information
 - e. Changes in distribution
3. This information is taken from the index listing in the brown microfiche. The index listing also explains how to update your microfiche library. There are also listings and sorts which will help you in ordering the following:
 - a. Hardware Manuals
 - b. Diagnostic Listings
 - c. Maindec/Package identifier Sort
 - d. Wire Lists
 - e. Technical Information
 - f. Module/Assembly Data
 - g. Miscellaneous
4. To place an order, make a written request (TWX or memo) to the location given above, including:
 - a. What you want
 - b. Name of the person who is to receive the information.
 - c. Cost Center
 - d. Mail Stop

TROUBLESHOOTING AIDS AND RESOURCES (cont.)

VIII. SOFTWARE DISTRIBUTION CENTER (SDC)

A. Location:

1. Digital Equipment Corporation
146 Main Street - ML11-3/E52
Maynard, MA 01754

B. Services Provided:

1. You may order the following useful documentation through the SDC:
 - a. Print Sets
 - b. Diagnostic Magtapes
 - c. KLAD Updates (See Good Stuff #8)
 - d. Software Product Descriptions (SPD's) - usually available in your Sales Office. They contain both Software and Hardware information.
2. Part Numbers can be found in the microfiche Index Listing.

C. Ordering Procedure:

1. Items may be ordered from the SDC using an Internal Order Form (IOF) like the one shown in Issue #8 of Good Stuff. You should have these in your office. Fill the form out and forward it to the SDC at ML11-3/E52.

TROUBLESHOOTING AIDS AND RESOURCES (cont.)

IX. COMMUNICATION SERVICES

A. Location:

1. NR2-2/M15

B. Services Provided:

1. Communication Services can provide you with manuals in hard copy form. You should order by TWX to the above location, including:
 - a. Your Name
 - b. Cost Center
 - c. Location
 - d. Document Part Number
2. There is an index published of what is available from Communication Services. Among the available documents are:
 - a. KL10 Maintenance Guide
 - b. KS10 Maintenance Guide
 - c. TOPS-10 Software Notebooks
 - d. TOPS-20 Software Notebooks

TROUBLESHOOTING AIDS AND RESOURCES (cont.)

X. LARGE BUFFER AND SMALL BUFFER

A. Location:

1. Administrative Services - Maynard
2. Telephone: DTN: 223-5886 or,
3. Write: PK2/E49 Attn.: Ann Bulger

B. Services Provided:

1. These two (2) publications often contain useful software information. To get on the distribution list, TWX the Administrative Services Group, including:
 - a. Name
 - b. Badge Number
 - c. Cost Center
 - d. Mail Stop
 - e. Telephone Number

IX. DECSYSTEM 10 AND DECSYSTEM 20 SOFTWARE DISPATCH

A. Location:

1. Software Services
Digital Equipment Corporation
200 Forest Street
Marlboro, MA 01752

B. Services Provided:

1. More useful software information. To get on the distribution list, TWX the Administrative Services group at the location given in Section X.

TROUBLESHOOTING AIDS AND RESOURCES (cont.)

XII. BUY LINE

A. Location:

1. MR1-1/M75

B. Services Provided:

1. The BUY-LINE often contains useful configuration, software, and general product information.
2. To receive BUY-LINE, send a memo to Anne Turner, at the above location, including:
 - a. Your Name
 - b. Badge Number
 - c. Cost Center
 - d. Location

XIII. VENDOR MANUALS

- #### A.
- If you need a vendor manual, you will probably need assistance from Product Support to obtain it. A few manuals are available from Communication Services (check their Index). These manuals are supplied to DEC (serialized to a specific option from the vendor) with the vendors equipment and additional copies are difficult to come by.

When you do receive a vendor manual, it should remain with the equipment.

TROUBLESHOOTING AIDS AND RESOURCES (cont.)

XIV. GOOD STUFF

A. Location:

1. Editorial Office: MR1-1/S35 - TWX Code: MR11

B. If you don't already receive Good Stuff, send a memo or TWX to Nancie Mitchell at the above location, including:

1. Your Name
2. Badge Number
3. Cost Center (700's ONLY)
4. Location Code

XV. OTHER SUPPORT GROUPS

A. Don't forget your own District, Area, and Regional Support Groups as resources available to you.



INTEROFFICE MEMORANDUM

TO: *Good Stuff Distribution*

DATE: *July 16, 1979*

FROM: *Herman Millet*

DEPT: *Current Product Engineering*

EXT: *4477*

LOC/MAIL STOP: *MR1-1/S35*

SUBJECT: *KL10 REVISION CONTROL AND COMPATIBILITY*

From the very beginnings of the KL10 Based Systems, the significance of compatibility constraints has been recognized to be an important part of the documentation requirements for these systems. The architecture of the KL10 is such that a change in any one part of the system might require a corresponding change in another part. For example, a hardware modification to one module in the system, might break a diagnostic. For this reason a Revision Control System was developed for KL10 Based Systems in an attempt to coordinate the release of several changes into one Integral System Revision Level.

The document which is utilized to provide the necessary information regarding revision changes is KL REV. This document is published in the Miscellaneous (purple header) Section of the microfiche library. By far, the single most useful listings in the entire document are the compatibility files. These compatibility listings, referred to as L C COMP (Large Computer Compatibility), have been proven to help fix system problems quite frequently. Unfortunately, we also suffer from misinterpretations of the listing, lack of reference to it, and careless use of the document.

My intention is to encourage frequent reference to the attached listings and also describe some common DO's and DON'Ts when referring to them.

A common problem which exists today is a lack of understanding of the evolution of the KL10 Based System and the abundance of different terminology used to describe the types of systems. Each KL10 has an Engineering Designation and corresponding Marketing Designation.

Also common today is reference to systems as either a Model "A" or Model "B" System. These terms are used to identify the difference between systems with either a KL10-PA CPU at 25 MHz or a KL10-PV CPU at 30 MHz. Refer to FIGURE 1 for a diagram of the KL10 Based Systems.

TO: Good Stuff Distribution

-2-

TO UNDERSTAND HOW TO UTILIZE THE COMPATIBILITY CHARTS -- IT MIGHT HELP TO KNOW THE PURPOSE OF THESE CHARTS...

The purpose of the compatibility chart is to define the revisions of modules which can be used in a system, at a particular Integral Revision Level. Customers may experience extended downtime waiting for a specific revision module to be ordered, when another revision module readily available in the Branch will fix the problem. Too often mistakes are made because a Field Engineer will refer to the Model "B" chart to troubleshoot a Model "A" system or vice versa. This will most certainly cause you and the customer grief. To illustrate the problems here, refer to the attached chart. Look at the M8519 revisions specified to be compatible for Model "A" and "B" at Revisions 12 and 4 respectively. You will see that for a Model "A" System, either module revision Level "A", "B", or "C", can be used, whereas; for Model "B", you must have a module at Revision Level "C".

In summary, we recommend you use the Compatibility Chart when troubleshooting a system. You must insure you are referencing the correct chart for the system you are troubleshooting. And finally, under no circumstances should you allow a customer's system to remain down while waiting for a later revision module, when an earlier revision will work and fix the problem.

If you have any questions, please call me at:

(617) 481-9511 Ext. 4477

or

DTN: 231-4477

Attachments

Regards,

Herman

KL10 BASED SYSTEMS

ENGINEERING DESIGNATIONS	MARKETING DESIGNATIONS	TYPE OF BACKPLANE	MODEL	CURRENT SYSTEM REVISIONS
KL10-A	1080	KL10-PA	A	12
KL10-B	1090	KL10-PA	A	12
KL10-C	2040 2050	KL10-PA	A	12
KL10-D	1090	KL10-PV	B	4
KL10-E	2040 2050 2060 1091	KL10-PV	B	4

FIGURE 1

KLREV SYSTEM REVISION CONTROL
LCCOMP.MA

COMPATIBLE MATRIX VARIATIONS
APPLY TO:

KL10-A
KL10-B
KL10-C

UNIT / MODULE
COMPATIBILITY
HISTORY
SECTION 9

DIGITAL EQUIPMENT
CORPORATION

STATE BRANDS AND SPECIFICATIONS:
THIS DRAWING AND THE EQUIPMENT OF
DIGITAL EQUIPMENT CORPORATION AND
OTHERS MAY BE REPRODUCED OR COPIED
OR USED IN WHOLE OR IN PART AS
LONG AS THE SOURCE IS PROPERLY
CITED AND THE REPRODUCER AGREES TO
PAY TO DIGITAL EQUIPMENT
CORPORATION THE COST OF REPRODUCTION.

REVISIONS		
CHR.	CHANGE NO.	REV.

	DATE ENR.	DATE	TITLE:
	DATE	DATE	KLREV SYSTEM REV CTL SEC 9
SHEET 1 OF 1 FIRST USED IN OPTION/MODEL/KL SYSTEM	RECD. LOCATION: N/A SHEET 1 OF 1 NONE	SIZE: D CODE: RC	NUMBER: KL10-0-REV REV.: A

KLCPUA, DMADIA AND RH20/DTE MODULE REVISION COMPATIBILITY HISTORY

REVISION DESCRIPTION:

- THE CHART WHICH FOLLOWS IS A SUMMARY OF MODULE REVISIONS RELEASED UNDER "KLCPU BASED SYSTEM" REVISIONS. THE DETAILS OF EACH REVISION ARE DOCUMENTED IN THE "KLCPU BASED SYSTEM REVISION DESCRIPTION" AND THE "MODULE REVISION HISTORY" LISTING FOR THE UNIT.
- THE CHART ALSO INCLUDES BACKWARDS COMPATIBILITY INFORMATION. BACKWARDS COMPATIBLE MODULES ARE THOSE LISTED AT A SPECIFIC REVISION WHICH MAY BE USED IN EARLIER REVISION UNITS - FOR EXAMPLE MANY MODULES RELEASED WITH "KLCPU BASED SYSTEM" REV 9A CAN BE USED IN REV 9 AND REV 8 UNITS.
- HOW TO READ THE CHART:
- ALL MODULE REVISIONS LISTED UNDER A SPECIFIC "KLCPU BASED SYSTEM" REVISION MAY BE USED IN THAT REVISION.
- MODULE TYPES SEPARATED BY COMMAS ARE FUNCTIONALLY IDENTICAL. THEY HAVE THE SAME LOGIC AND ARE INTERCHANGEABLE. IN SOME CASES THE MODULE WAS RELAYED OUT TO REMOVE ECO WIRES AND DIFFERS FROM THE OLDER VERSION ONLY IN THE LOCATION OF SPECIFIC IC'S ON THE MODULE (E NUMBERS). IN OTHER CASES A CHANGE WAS MADE TO SOME COMPONENTS OR DOCUMENTATION WHICH DOES NOT AFFECT THE OPERATION OF THE MODULE.
- MODULE TYPES SEPARATED BY A (<>) ARE COMPATIBLE WITH SPECIFIC "KLCPU BASED SYSTEM" REVISIONS HOWEVER THEY ARE NOT FUNCTIONALLY IDENTICAL - THE LOGIC ON THE MODULES IS DIFFERENT. THE REASON THAT BOTH MODULES MAY BE USED AT A SPECIFIC "KLCPU BASED SYSTEM" REVISION IS THAT THE LOGIC CHANGE INVOLVED IS SMALL AND DOES NOT AFFECT DIAGNOSTICS, BACKPANEL WIRING, MICROCODE, OR OTHER MODULES.

<small>ITS NUMBER AND SPECIFICATIONS, etc. and the purpose of this equipment comparison and will be referenced on certain used to make up in part as I. Most use the number and items without missing system. Copyright © 1974. All Rights Reserved.</small>	REVISIONS CHANGE NO. REV		DATE ENG. DATE DATE SHEET 2 OF 4		DATE FILED DATE SHEET 2 OF 4		TITLE: KLREV SYSTEM REV CTL SEC 9	
	DRA Family DATE 12-01-78		DATE 12-01-78 SHEET 2 OF 4		DATE 12-01-78 SHEET 2 OF 4		SIZE CODE NUMBER REV. D RC KL10-0-REV A	

CPU "A" UNIT TOP LEVEL REVISION HISTORY

CPU "A" MODULE REVISION COMPATIBILITY HISTORY

CPU A UNIT REV	7	7A	7B	8	9	9A	9B	9C	10	10A	10B	11	12
M8510	A	A	A	A	A	A	A	A	A	A	A	A	A
M8511	B	B,C	B,C	B,C	B,C	B,C	B,C	B,C	B,C	B,C	B,C	B,C	B,C
M8512	A	A	A	A,B	A,B	A,B	A,B	A,B	A,B,C	A,B,C	A,B,C	A,B,C	A,B,C
M8513	C	C	C	D,E	D,E	D,E	D,E	D,E	D,E,F	D,E,F	D,E,F	D,E,F	D,E,F
M8516	D,E	D,E	D,E	D,E	D,E	D,E	D,E	D,E	D,E	D,E	D,E	D,E	D,E
M8517	A<B	A<B	A<B	A<B	A<B	B	B	B	B	B	B	B	B
M8518	B	B	B	B	B	B	B	B	B	B	B	B	B
M8519	A	A	A	A,B,C	A,B,C	A,B,C	A,B,C	A,B,C	A,B,C	A,B,C	A,B,C	A,B,C	A,B,C
M8520	C	C	C	D	D	D	D	D	D	D	D	D	D
M8522	A	A	A	A	A	A	A	A	A	A	A	A	A
M8523	B,C	B,C	B,C	B,C	B,C	B,C	B,C	B,C	B,C	B,C	B,C	B,C	B,C
M8524	C	C	C	C	C	C	C	C	D,E	D,E	D,E	D,E	D,E
M8525	D	D	D	D	E,F,H	E,F,H	E,F,H	E,F,H	E,F,H	E,F,H	E,F,H	E,F,H	E,F,H
M8526	D	D	D	E	E<F<H	E<F<H	F<H	F<H	F<H	F<H	F<H	F<H	F<H
M8527	D	D	D	D	E	E	E	E	E	E	E	E	E
M8528	B	B	B	B	B	B	B	B	B	B	B	B	B
M8529	B	B	B	C,C1,D	C,C1,D	C,C1,D	C,C1,D	C,C1,D	C,C1,D	C,C1,D	C,C1,D	C,C1,D	C,C1,D
M8530	C	C	C	C	C	C	C	C	D	D	D	D	D
M8531	B	B	B	B,C	B,C	B,C	B,C	B,C	B,C	B,C	B,C	B,C	B,C
M8532	C	C	C	D	D	D	D	D	D,E	D,E	D,E	D,E	D,E
M8537	B	B	B	C,D	C,D	C,D	C,D	C,D	C,D	C,D	C,D	C,D	C,D
M8538	B	B	B	C	C,D	C,D	C,D	C,D	C,D	C,D	C,D	C,D	C,D
M8539	B	B	B	B	B	B	B	B	B	B	B	B	B

CACHE MODULE REVISION COMPATIBILITY HISTORY

CACHE REV	7	7A	7B	8	9	9A	9B	9C	10	10A	10B	11	12
M8514	A	A	A	A	A	A	A	A	A	A	A	A	A
M8515	B	B	B	B	B	B	B	B	B	B	B	B	B
M8521	A	A	A	A	A	A	A	A	A	A	A	A	A

CACHE SUBSTITUTE MODULE REVISION HISTORY

CACHE REV	7	7A	7B	8	9	9A	9B	9C	10	10A	10B	11	12
M8549YE	A	A	A	A	A	A	A	A	A	A	A	A	A
M8549YF	A	A	A	A	A	A	A	A	A	A	A	A	A
M8549YH	A	B	B	B	B	B	B	B	B	B	B	B	B

CPU "A" UNIT TOP LEVEL REVISION HISTORY

CPU A UNIT REV 7 7A 7B 8 9 9A 9B 9C 10 10A 10B 11 12

CHANNEL MODULE REVISION COMPATIBILITY HISTORY

M8533	B	B	B	B	B	B	B	B	C	C	C	C	C
M8534	B	B	B	C	C	C	C	C	C,D	C,D	C,D	C,D	C,D
M8535	B	B	B	B<C,D	B<C,D	C,D	C,D	C,D	C,D	C,D	C,D	C,D	C,D
M8536	B	B	B	B<D,E	C<D,E	D,E	D,E	D,E	D,E	D,E	D,E	D,E	D,E

CHANNEL SUBSTITUTE MODULE REVISION HISTORY

M8549YA	A	A	A	A	A	A	A	A	A	A	A	A	A
M8549YC	A	A	A	A	A	A	A	A	A	A	A	A	A
M8549YD	B	B	B	B	B	B	B	B	B	B	B	B	B

DMADIA UNIT TOP LEVEL REVISION HISTORY

DMADIA UNIT REV 7 7A 7B 8 9 9A 9B 9C 10 10A 10B 10B 12

DMADIA MODULE REVISION COMPATIBILITY HISTORY

M8550	B,C	B,C	B,C	B,C	B,C	B,C	B,C	B,C	B,C	B,C	B,C	B,C	B,C
M8551	B	C	C	C	C	C	C	C	C	C	C	C	C
M8558	B	B	B	B,C	B,C	B,C	B,C	B,C	B,C,D	B,C,D	B,C,D	B,C,D	B,C,D
M8560	B	B	B	B,C	B,C	B,C	B,C	B,C	B,C	B,C	B,C	B,C	B,C
M8563	C<D	C<D	C<D	C<D,E	C<D,D1	D,D1	D,D1	D,D1	D,D1	D,D1	D,D1	D,D1	D1,F

RH20/DTE UNIT TOP LEVEL REVISION HISTORY

RH20/DTE UNIT REV 7 7A 7B 8 9 9A 9B 9C 10 10A 10B 11 12

RH20/DTE MODULE REVISION COMPATIBILITY HISTORY

M8552	D<E	D<E	D<E	D<E	D<E,F	E,F	E,F	E,F	E,F	E,F	E,F	E,F	E,F
M8553	C	D,E<F<H	D,E<F<H	D,E<F<H	D,E<F<H	F<H,J,K	H,J,K	H,J,K	H,J,K,L	H,J,K,L	H,J,K,L	H,J,K,L	H,J,K,L
M8554	C<D	C<D	C<D	C<D,F	C<D,F	D,F	D,F	D,F	D,F	D,F	D,F	F	F
M8555	C	C	C	C,D,E	C,D,E	C,D,E	C,D,E	C,D,E	C,D,E	C,D,E	C,D,E	D,E	D,E
M8556	C<E<F	C<E<F	C<E<F	C,D<E<F	C,D<E<F	C,D<E<F	C,D<E<F	C,D<E<F	C,D<E<F	C,D<E<F	C,D<E<F	D<E<F	E<F
M8557	C	C	C	C	C	C	C	C	C	C	C	D	D1,E
M8559	A	A	A	A	A	A	A	A	A	A	A	A	A

FORMING AND SPECIFICATIONS
in and the purpose of
the equipment contained here
is not intended to be used
in any way other than that
intended by the manufacturer
and is not to be construed
as a warranty of any kind
or a statement of fact.

REV	CHG	NO	REV

DATE ENG. CHG. NO.	DATE FILED	FILE NO.	KLREV SYSTEM REV CTL SEC 9
DATE	DATE	DATE	
ROOM LOCATION	ROOM LOCATION	ROOM LOCATION	NUMBER
SHEET	SHEET	SHEET	REV.
DESCRIPTION (ITEM NO.)	DATE	BY	KL10-0-REV
FIRST USED ON OPTION/MODEL/LIKE SYSTEM	NONE		A

KLREV SYSTEM REVISION CONTROL LCCOMP.MB

COMPATIBLE MATRIX VARIATIONS
 APPLY TO:

KL10-D
 KL10-E

UNIT / MODULE
 COMPATIBILITY
 HISTORY
 SECTION 10

DIGITAL EQUIPMENT
 CORPORATION

THIS SHEET AND SPECIFICATIONS
 HEREIN ARE THE PROPERTY OF
 DIGITAL EQUIPMENT CORPORATION AND
 SHALL BE REPRODUCED OR
 COPIED IN WHOLE OR IN PART
 WITHOUT THE WRITTEN CONSENT
 OF DIGITAL EQUIPMENT CORPORATION.

REVISIONS	
CHG	CHANGE NO. REV

	DATE	ENG.	DATE	TITLE
	REV. DATE	NO. REV. DATE	NO. REV. DATE	KLREV SYSTEM REV CIL SEC 10
FIRST USED ON OPTION/MODEL/CL SYSTEM NONE	BOARD LOCATION SHEET 1 OF 3	HIGHER ASSEMBLY NONE	SIZE CODE D RC	NUMBER KL10-0-REV A

KLC PUB, DMADIA AND RH20/DTE MODULE REVISION COMPATIBILITY HISTORY

REVISION DESCRIPTION:

- THE CHART WHICH FOLLOWS IS A SUMMARY OF MODULE REVISIONS RELEASED UNDER "KLCPU BASED SYSTEM" REVISIONS. THE DETAILS OF EACH REVISION ARE DOCUMENTED IN THE "KLC PUB BASED SYSTEM REVISION DESCRIPTION" AND THE "MODULE REVISION HISTORY" LISTING FOR THE UNIT.
- THE CHART ALSO INCLUDES BACKWARDS COMPATIBILITY INFORMATION. BACKWARDS COMPATIBLE MODULES ARE THOSE LISTED AT A SPECIFIC REVISION WHICH MAY BE USED IN EARLIER REVISION UNITS - FOR EXAMPLE MANY MODULES RELEASED WITH "KLCPU BASED SYSTEM" REV 1 CAN BE USED IN REV 2A AND REV 3 UNITS.
- HOW TO READ THE CHART:
- ALL MODULE REVISIONS LISTED UNDER A SPECIFIC "KLCPU BASED SYSTEM" REVISION MAY BE USED IN THAT REVISION.
- MODULE TYPES SEPARATED BY COMMAS ARE FUNCTIONALLY IDENTICAL. THEY HAVE THE SAME LOGIC AND ARE INTERCHANGEABLE. IN SOME CASES THE MODULE WAS RELAYED OUT TO REMOVE ECO WIRES AND DIFFERS FROM THE OLDER VERSION ONLY IN THE LOCATION OF SPECIFIC IC'S ON THE MODULE (<E NUMBERS>). IN OTHER CASES A CHANGE WAS MADE TO SOME COMPONENTS OR DOCUMENTATION WHICH DOES NOT AFFECT THE OPERATION OF THE MODULE.
- MODULE TYPES SEPARATED BY A (<<) ARE COMPATIBLE WITH SPECIFIC "KLCPU BASED SYSTEM" REVISIONS HOWEVER THEY ARE NOT FUNCTIONALLY IDENTICAL - THE LOGIC ON THE MODULES IS DIFFERENT. THE REASON THAT BOTH MODULES MAY BE USED AT A SPECIFIC "KLCPU BASED SYSTEM" REVISION IS THAT THE LOGIC CHANGE INVOLVED IS SMALL AND DOES NOT AFFECT DIAGNOSTICS, BACKPANEL WIRING, MICROCODE, OR OTHER MODULES.

IS THIS THE SPECIFICATION? 1. Do all the drawings of the equipment conform to the latest approved copies of the drawings of the parts of the equipment and the drawings of the components of the equipment?	REVISIONS CHG. CHANGE NO. REV.		DATE ENG. DATE BOARD LOCATION SHEET 2 OF 3	DATE DATE SHEET 2 OF 3	TITLE KLREV SYSTEM REV CTL SEC 10		
1. Do all the drawings of the equipment conform to the latest approved copies of the drawings of the parts of the equipment and the drawings of the components of the equipment?		DIGITAL DATE 12-01-78 SHEET 2 OF 3	DATE 12-01-78 SHEET 2 OF 3	DATE 12-01-78 SHEET 2 OF 3	KLREV SYSTEM REV CTL SEC 10		
8	7	6	5	4	3	2	1

D
 C
 B
 A

CPU "B" UNIT TOP LEVEL REVISION HISTORY

CPU B UNIT REVISION	1	2	2A	3	4

CPU B MODULE REVISION COMPATIBILITY HISTORY					
M8512	B,C	B,C	B,C	B,C	B,C
M8513YA	B	B	B	B	B
M8514	A	A	A	A	A
M8515	B	B	B	B	B
M8516	D,E	D,E	D,E	D,E	D,E

M8517	B	B	B	B	B
M8518YA	A	A	A	A	A
M8519	C	C	C	C	C
M8520YA	A	A	A	A	A
M8521	A	A	A	A	A

M8522	A	A	A	A	A
M8524	D,E	D,E	D,E	D,E	D,E
M8525	F,H	H	H	H	H
M8526YA	B	B	B	B	B
M8529YA	A	A	A	A	A

M8531YA	A	A	A	A	A
M8532	D,E	D,E	D,E	D,E	D,E
M8533	C	C	C	C	C
M8534	C,D	C,D	C,D	C,D	C,D
M8535	D	D	D	D	D

M8536	E	E	E	E	E
M8537	D	D	D	D	D
M8538	C,D	C,D	C,D	C,D	C,D
M8540	A	A	A	A	A
M8541	A	A	A	A	A

M8542	A	A	A	A	A
M8543	A	A	A	A	A
M8544	A	A	A	A	A
M8545	A	A	A	A	A
M8548	A	A	A	A	A

THIS DRAWING AND SPECIFICATIONS
 SHALL BE THE PROPERTY OF
 DIGITAL EQUIPMENT CORPORATION AND
 SHALL NOT BE REPRODUCED OR
 COPIED IN ANY MANNER OR
 BY ANY MEANS WITHOUT EXPRESS
 PERMISSION OF DIGITAL EQUIPMENT CORPORATION.

REVISIONS	
CHK	CHANGE NO. REV

	DATE WNG.	DATE	TITLE
	DATE	DATE	REV. CIL SEC 10
DSPILLSETB, T2P14, G123 FIRST USED ON OPTION/MODEL/KL SYSTEM	DATE 24-OCT-74 1615	DATE 24-OCT-74 1615	NEXT HIGHER ASSEMBLY PHONE
SIZE D	CODE RC	NUMBER KL10-0-REV	REV. A

CPU "B" UNIT TOP LEVEL REVISION HISTORY

CPU B UNIT REVISION	10	10A	10B	11	12
---------------------	----	-----	-----	----	----

CPU B MODULE REVISION COMPATIBILITY HISTORY

M8549YA	A	A	A	A	A
M8549YC	A	A	A	A	A
M8549YD	B	B	B	B	B
M8549YE	A	A	A	A	A
M8549YF	A	A	A	A	A
M8549YH	B	B	B	B	B

DMADIA UNIT TOP LEVEL REVISION HISTORY

DMADIA UNIT REV	10	10A	10B	10B	12
-----------------	----	-----	-----	-----	----

DMADIA MODULE REVISION COMPATIBILITY HISTORY

M8550	B,C	B,C	B,C	B,C	B,C
M8551	C	C	C	C	C
M8558	C,D	C,D	C,D	C,D	C,D
M8560	C	C	C	C	C
M8563	D,E	D1,F	D1,F	D1,F	D1,F

RH20/DTE UNIT TOP LEVEL REVISION HISTORY

RH20/DTE UNIT REV	10	10A	10B	11	12
-------------------	----	-----	-----	----	----

RH20/DTE MODULE REVISION COMPATIBILITY HISTORY

M8552	E,F	E,F	E,F	E,F	E,F
M8553	J,K,L	J,K,L	J,K,L	J,K,L	J,K,L
M8554	F	F	F	F	F
M8555	C,D,E	C,D,E	C,D,E	D,E	D,E
M8556	C,D<E<F	C,D<E<F	C,D<E<F	D<E<F	E<F
M8557	C	C	C	D	D1,E
M8559	A	A	A	A	A

<small>THIS DRAWING AND SPECIFICATIONS ARE THE PROPERTY OF THE COMPANY AND ARE NOT TO BE REPRODUCED OR COPIED IN ANY MANNER WITHOUT THE WRITTEN PERMISSION OF THE COMPANY.</small>	REVISIONS CHG. CHANGE NO. REV.		DATE 12-1-78 127-001-00 00122	DATE 12-1-78	EMB. NONE	DATE 12-1-78	TITLE KLREV SYSTEM REV CTL SEC 10	SHEET 3 OF 3	BOARD LOCATION N/A	SIZE CODE D FC	NUMBER KL10-0-REV	REV. A
	FIRST USED ON OPTION MODEL: KL SYSTEM											

stuff

COMPANY CONFIDENTIAL

This document contains sensitive information which shall not be disclosed to personnel outside of Digital Equipment Corporation

This Newsletter is meant as an information document. Its contents are not necessarily Company Policy. It's a means by which LCG Product Support can distribute some tidbits of information to you.

IN THIS ISSUE...

● HARDWARE

- PAPER FEED FAILUREPage 3
- RP10 READ DATA SEPARATOR ADJUSTMENT.Page 4
- CORRECTION - CRASH FILE FOR 2020Page 5
- W516 CALIBRATIONPage 6
- EXTERNAL MEMORY PORT JUMPERSPage 6

● MISCELLANEOUS

- BOXER FANSPage 6
- CAN YOU BEAT THIS.Page 7

● SOFTWARE

- SWP??? BUGHLTSPage 8
- 11 HALT LRF.Page 8
- TURNING CACHE OFF FOR TOPS10Page 9
- CARD READER PROBLEMS WITH RELEASE 3APage 10
- ANALYZE THAT CRASHPage 10

SEND ANY ARTICLES WHICH YOU FEEL SHOULD APPEAR IN GOOD STUFF TO:

GOOD STUFF EDITORIAL OFFICE
c/o NANCIE MITCHELL
MR1-1/S35
DTN: 231-5148
TWX CODE: MR11

ANY FIELD SERVICE EMPLOYEE (700 COST CENTERS ONLY) REQUESTING GOOD STUFF MUST SUBMIT A MEMO OR TWX TO:

SAME AS ABOVE

WITH THE FOLLOWING INFORMATION:

- NAME
- BADGE #
- COST CENTER
- LOCATION CODE

*NIGEL WEBB IS NOW THE EDITOR OF GOOD STUFF.
AS EDITOR, NIGEL HAS ALL RESPONSIBILITIES
PREVIOUSLY BELONGING TO ART O'DONNELL.*

EDITOR.....	NIGEL WEBB
ASSOC. EDITOR.....	NANCIE MITCHELL
EDITORIAL OFFICE.....	MR1-1/S35

GOOD STUFF is published on a monthly-basis.

PAPER FEED FAILURE
BY: PHIL SCHWARTZ
FIELD SERVICE - SOMERSET

PROBLEM: MDS5300 LINE PRINTER WILL NOT FORM FEED

The above problem was caused by a missing spacer in the low speed magnetic field clutch assembly, part #: 29-1600, which had been replaced recently. The 29-1600 kit is missing this spacer.

FIX:

Take the spacer out of the old clutch assembly and install it in the new one. (The end of the rotor shaft might have to be filed down to get it out of the clutch, before the spacer can be removed.)

(SEE DIAGRAM BELOW)

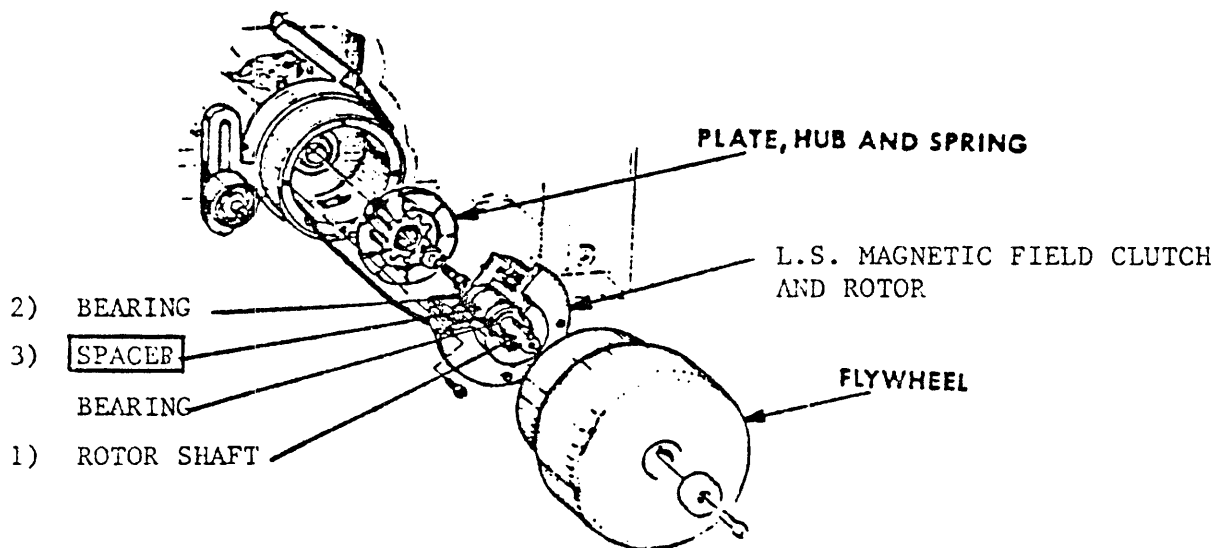

NOTE: REMOVE IN THIS ORDER:
1, 2, 3,

RP10 READ DATA SEPARATOR ADJUSTMENT

BY: ROY SEQUEIRA
PRODUCT SUPPORT - MARLBORO

Here is a method for adjusting the read data separator on the RP10 without pulling modules or using jumpers. It assumes the RP10 is otherwise okay, and the availability of a previous formatted disk pack.

This method is an adaptation of the method in the manual and has been successfully tried at two customer sites.

ALL MEASUREMENTS ARE AT -1.5V UNLESS OTHERWISE STATED

Put the RP10 in "local", the drive ready, and do a "read" on any formatted track.

1. Scope T22H, and adjust the lower pot on B410 at T22 for negative pulse 50 nanoseconds wide.
2. Scope T29V, +VE trigger, and adjust B312 at T29 for 50 nanoseconds pulse.
3. Connect channel 1 to S24L, channel 2 to S24V, and adjust B312 at S24 until delay between pulses (leading edge to leading edge) is 80 nanoseconds.
4. Scope S28P (RDS DATA WIND), and adjust B312 at T25 until the waveform is equally divided between +VE and -VE halves.
5. Sync -VE on channel 1, connect channel 1 to S32M (RDS CLOCK WIND (O)L), Channel 2 to T30H (RDS EXT DATA WIND L), and adjust B312 at S24 until waveforms cross at -1.5V level.
6. Connect channel 1 to S32M (RDS CLOCK WIND (O)L), channel 2 to S32L (RDS DATA in L), and adjust B312 at T25 until the delay between channels 1 and 2 is 105 nanoseconds. (Negative going edges).
7. Connect channel 1 to T24D (RDS ERR A), channel 2 to T24N (RDS ERR B), and adjust upper pot B410 at T22 until the waveshapes exactly match.

THIS WHOLE ADJUSTMENT TAKES ABOUT 20 MINUTES

I would appreciate hearing from anyone who uses this method - contact me in Marlboro:

ROY SEQUEIRA
c/o MR1-1/S35
617-481-9511
ext. 6903, 6904

Cross Reference: RP10-TT-6

This article was published in Good Stuff #21 (August FY'80). It was published with errors. Please note corrections (*) below.

Sorry.

CRASH FILE FOR 2020
BY: BOB BARR
REGIONAL SUPPORT - KANATA

Below, please find my proposed crash file for 2020. It should provide enough information to correct most problems.

All information and references can be found in KS REF.

20 CRASH FILE

This file is to be used on any hung or halted system.

^ \ (Control Backslash)	Enter KS mode
CH,TEO,TPO	Halt clock, disable traps and timer.
EI	What register is in use?
EC	Examine current ucode address.
EB	Examine the KS Bus.
SM1	Save status block.
ECO	Reset ucode to 0
CS	Start the clock.
CH	Halt the clock.
EC	In the halt loop?
EM17	Can you examine memory?
* EX 700000 20,EM 20	APRID, OPTIONS,SERIALS
* EX 700240 20,EM 20	Read APR.
* EX 701040 20,EM 20	Read UBR.
* EX 701240 20,EM 20	Read EBR.
EI 1763100	Read UBA#1 Status Reg.
EI 3763100	Read UBA#3 Status Reg.
EI 100000	Read Memory Status Reg.

W516

W516 CALIBRATION

BY: NIGEL WEBB

LSG SYSTEMS SUPPORT - MARLBORO

Approximately, 18-months ago, a problem was discovered with the calibration of the W516 module used in the 863 power control of the KL-based systems.

The effect of this problem was that some W516 modules were adjusted to give a low voltage indication at a higher voltage than the specification shows.

If you are maintaining a KL-based system that was shipped from Marlboro more than 18-months ago, and you have reasonable evidence to show that the system is getting power-fails before the specified voltage tolerances are reached, you should replace the W516 module and return the original for re-calibration.

NOTE: The calibration of the W516 is a factory adjustment only.

EXTERNAL MEMORY PORT JUMPERS

BY: DINO GENOVA

LCG PRODUCT SUPPORT - MARLBORO

The brown 3 1/2 inch jumpers are used on the MG10 and MH10 memories for ease checkout during the Manufacturing process. It is recommended that when you install one of these memories you hard-wire these jumpers according to the type of device used in the particular port.

This wire should be the green 30 gauge wire used for ECO work done on logic backplanes.

MISCELLANEOUSBOXER FANS

BY: DINO GENOVA

LCG PRODUCT SUPPORT - MARLBORO

It is recommended that Boxer fans be used, wherever possible, instead of the Torin Fans. This is due to two reasons:

1. The boxer fans do not fail as often.
2. Air flow is improved since the boxer fan has seven blades versus five blades in the other fans.

The part number for these fans is:

(12-9403-02) 115V

CAN YOU BEAT THIS

A DecSystem 1090 in the DEC Data Center, Maynard, has set a record for the greatest number of uninterrupted crash free hours:

691 HOURS 44 MINUTES

SOME BACKGROUND ON THE SYSTEM:

This 1090 is a heavily loaded system running Manufacturing and Corporate EPLS (Engineering Production Library System) applications. The system consists of a Model B KL10, with 20 Disk Drives (RPO3's, RPO4's, RPO6's), 12 Tape Drives (TU40's, TU70's, TU72's), 512K of memory, and three Communication Front Ends on a DL10. Exec PM's are done bi-monthly with Peripheral PM's done on-line.

THE PEOPLE RESPONSIBLE ARE:

- Ron Harkins - Field Service Account Representative
- Roger Nassar - Software
- Dave O'Brien - Operations

IF YOU HAVE A SYSTEM IN YOUR BRANCH THAT BEATS THIS RECORD LET US KNOW. YOU SHOULD GET THE RECOGNITION YOU DESERVE.

SEND THIS INFORMATION TO:

GOOD STUFF EDITORIAL OFFICE
MR1-1/S35
ATTENTION: NANCIE MITCHELL

SWP??? BUGHLTS

BY: CLIFF ROMASH
PRODUCT SUPPORT - NER

The eight TOPS-20 Bugchk/Bughlt's listed below are usually a direct result of an unrecoverable disk error. These Bughlt's are caused by a hardware problem (or a bad pack). Information regarding the actual disk error can be found in SYSERR by looking for disk errors immediately before or after the crash. If it is not clear from SYSERR what is causing the problem, it is possible to determine from a monitor dump the channel, unit, and contents of the drive registers from the unit causing the problem. AC P1 (10) has the contents of CHNTAB + channel number. AC P3 (12) has the contents of (P1) + CDBUDB + unit number. The drive registers can be found starting at (P3) + RP4REG.

The Bugchk/Bughlt's that this concerns are:

SWPFPE -- BUGCHK
SWPIBE -- BUGCHK
SWPJSB -- BUGCHK
SWPMNE -- BUGHLT
SWPPSB -- BUGHLT
SWPPTD -- BUGHLT
SWPPT -- BUGHLT
SWPUPT -- BUGHLT

NOTE:

Refer to Goodstuff #8 - Page 4,
Troubleshooting TOPS20 Machines.

11 HALT LRF

BY: CLIFF ROMASH
PRODUCT SUPPORT - NER

The RSX20F halt "LRF" means Load Request Failed. RSX20F was unable to load a swappable module of the front-end system (KLERR, PARSER, etc.). This can happen in several ways.

First, if you boot from floppies or dectape and remove the load media after the system is running,

and

Second, it can be caused by a hardware error on the original boot media, e.g., the front-end disk drive.

TURNING CACHE OFF FOR TOPS10

BY: RICK ELLISON

ROCKY MOUNTAIN DISTRICT SUPPORT

The following procedure will turn off the cache under TOPS10 (good for 6.03 and 6.03A).

To BOOTS type the following (monitor type out is underlined):

```

BTS> filespec/L
BTS> /401
BTS> /G
EDDT
SYSINI ($) : <tab> ↓
ACCINI - 16 / IORM T1, .COEBR <tab> JFCL ↓
HIGHIN ($) B <tab> 400 ($) G
$1B>>HIGHIN
KLSE ($) : <tab> ↓
CSDMP / PUSHJ P, SAVT <tab> POPJ P,
($) B <tab> ($) P
WHY RELOAD? etc.

```

NOTES:

1. The location of "ACCINI - 16" is for 6.03 and 6.03A.
2. The "JFCL" keeps the "look and load" bits from being turned on in the word the monitor used to set up the EBR.
3. "CSDMP" is the routine which flushes CACHE for I/O Bus operations. If you don't have a cache working then you don't need to flush it, do you.
4. The breakpoint at HIGHIN is to allow the monitor to set up its' page map for the write protected code.
5. is the carriage return key.
6. <tab> is a non-printing horizontal tab character.
7. \$ is the ESCAPE key.

RSX20F will turn off the "look and load" bits (via KLI). TOPS20 never turns them back on. TOPS10 turns them back on unless this patch is installed.

IF YOU HAVE A 1088 SYSTEM--THIS WILL TURN CACHE OFF ONLY ON CPU 0

CARD READER PROBLEMS WITH RELEASE 3A

BY: SCOTT HEMPHILL
SOFTWARE SERVICES - MARLBORO

Two monitor problems have become known with card readers on 20s. The patches below provide fixes for these problems. These patches apply only to KL-processors, i.e.: they do not apply to 2020's.

```
@ENABLE
$GET PS:<SYSTEM>MONITR
$ST 140
DDT
```

```
; Patch to fix status checking problems
; This is the one which make you have to hit the RESET button at
; the end of the SPRINT deck, or makes you have to add an extra card
; to the end of a deck.
```

```
CDVTFE+4/  SETZ CDRTLS      SETZ KLRSTS
```

```
; Patch to not read ahead if error (pick check, etc.) is detected
```

```
FFF/  0  6,,37
KLRSTS-3/  TRNE T1,10  TDNE T1,FFF
FFF+1/  0  FFF:
```

```
^Z
$SAVE PS:<SYSTEM>
<SYSTEM>MONITR.EXE.2 Saved
$
```

ANALYZE THAT CRASH

BY: BOB MALONEY
LCG PRODUCT SUPPORT - MARLBORO

If any person requires a TOPS10 software crash dump analyzed, the following information should be collected:

1. Name of crash to be analyzed.
2. Area where the crash dump is. e.g.: DSKC:[10,1], etc.
3. Name and area of a monitor. e.g.: SYS:DEC.EXE[1,4]
4. Description of crash (from Site Management Guide).
5. PPN and Password.
6. Dial-up phone number.
7. Person's name (Digital) to contact with results.

GOOD STUFF

COMPANY CONFIDENTIAL

This document contains sensitive information which shall not be disclosed to personnel outside of Digital Equipment Corporation.

This Newsletter is meant as an information document. Its contents are not necessarily Company Policy. It's a means by which LCG Product Support can distribute some tidbits of information to you.

IN THIS ISSUE...

** KL10 REVISION 12/4 STATUS UPDATE PAGES 12 - 13 **
** PLEASE READ - IMPORTANT **

● DIAGNOSTICS

- DF10/DF10-C. Page 3
- FIX - DDRPI MUO FAILURES ON KL10PV WITH RH10 (EXEC MODE). Page 3

● HARDWARE

- RP04 ACCESS TRANSDUCER Page 4
- REGISTER ACCESS ERROR ANALYSIS Page 6
- MODULE SWAPPING. Page 9

● MISCELLANEOUS

- KL10 REVISION 12/4 STATUS UPDATE Page 12
- GOOD STUFF ON SPEED BULLETIN Page 14

● SOFTWARE

- SUPPORT OF TOPS-10 VERSION 6.03. Page 14

● SUPPLEMENT: DEALING WITH TOPS-20 SWAPPING BUGHLTS

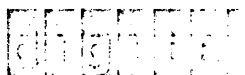

SEND ANY ARTICLES WHICH YOU FEEL SHOULD APPEAR IN GOOD STUFF
TO:

GOOD STUFF EDITORIAL OFFICE
c/o NANCIE MITCHELL
MR1-1/S35
DTN: 231-5148
TWX CODE: MR11

ANY FIELD SERVICE EMPLOYEE (700 cost centers only)
REQUESTING GOOD STUFF MUST SUBMIT A MEMO OR TWX TO:

SAME AS ABOVE

WITH THE FOLLOWING INFORMATION:

- NAME
- BADGE #
- COST CENTER
- LOCATION CODE

EDITOR Nigel Webb
ASSOC. EDITOR..Nancie Mitchell
EDITORIAL OFFICE.... MR1-1/S35

GOOD STUFF is published on a
monthly-basis.

DF10/DF10-C

BY: JOHN ANDRUSZKIEWICZ
WESTERN REGION - PRODUCT SUPPORT

It should be noted that diagnostic DDDFA Version 0.3, will run error free, even when there are "solid bit failures" in the data address register. The bits that aren't checked are 19, 20, and 21. Diagnostic Engineering is presently working on a new release.

If this problem is present, the RP10 diagnostic (DDRPB) will fail. However, the RH10 diagnostic (DDRHA) will not fail; and the system exerciser (DDQCB) will fail.

FIX *** FIX *** FIX

DDRPI MUUO FAILURES ON KL10PV
WITH RH10 (EXEC MODE)

BY: BILL SCORZELLI
DIAGNOSTIC ENGINEERING

DDRPI will not run on KL10PV (Model B) based systems on an RH10 sub-system. (Constant MUUO errors and page fail trap errors).

DDRPI Version 0.7 fixes this problem (DDRPIGO).

Cross Reference: Good Stuff -
Issue #21, Page 3.

RPO4 ACCESS TRANSDUCER
 BY: JEAN BREARD
 FIELD SERVICE - RUNGIS, FRANCE

BEFORE CHANGING A SUSPECTED ACCESS TRANSDUCER--CHECK THE LEVEL OF THE SOURCES AND SENSORS. IF THEY ARE NOT CORRECT THIS CAN BE DUE TO THE CARD FEEDING THE ACCESS TRANSDUCER.

<u>SIGNAL</u>	<u>PIN</u>	<u>LEVEL</u>
THERMRET	A1533	0 V (Ground)
VELOCITY SAFETY SOURCE DRIVE	B16P2-11	11.40 V
CYLINDER VICINITY SOURCE DRIVE	B16P2-1	11.40 V
SOURCE 2 DRIVE	B16P2-3	11.40 V
SOURCE BIAS	B16P2-15	12.0 V
SENSORBIAS	A1539	\approx -6.0 V
SENSORSIGND	A1507	0 V (Ground)
CYLVCTHERM 1	A1538	+0.4 V
CYLVCTHERM 2	A1534	+0.4 V
CONNECT DDU WITH FAILSAFE INHIBIT + EMA DISABLE AND MOVE CARRIAGE		
VELSAFTYSIG	B1609	1 V P/P 
CYLVICSNSIG	A1509	\approx 100 mV P/P
SENSOR 2 SIG	A1505	\approx 100 mV P/P

DRAWING ON NEXT PAGE \longrightarrow

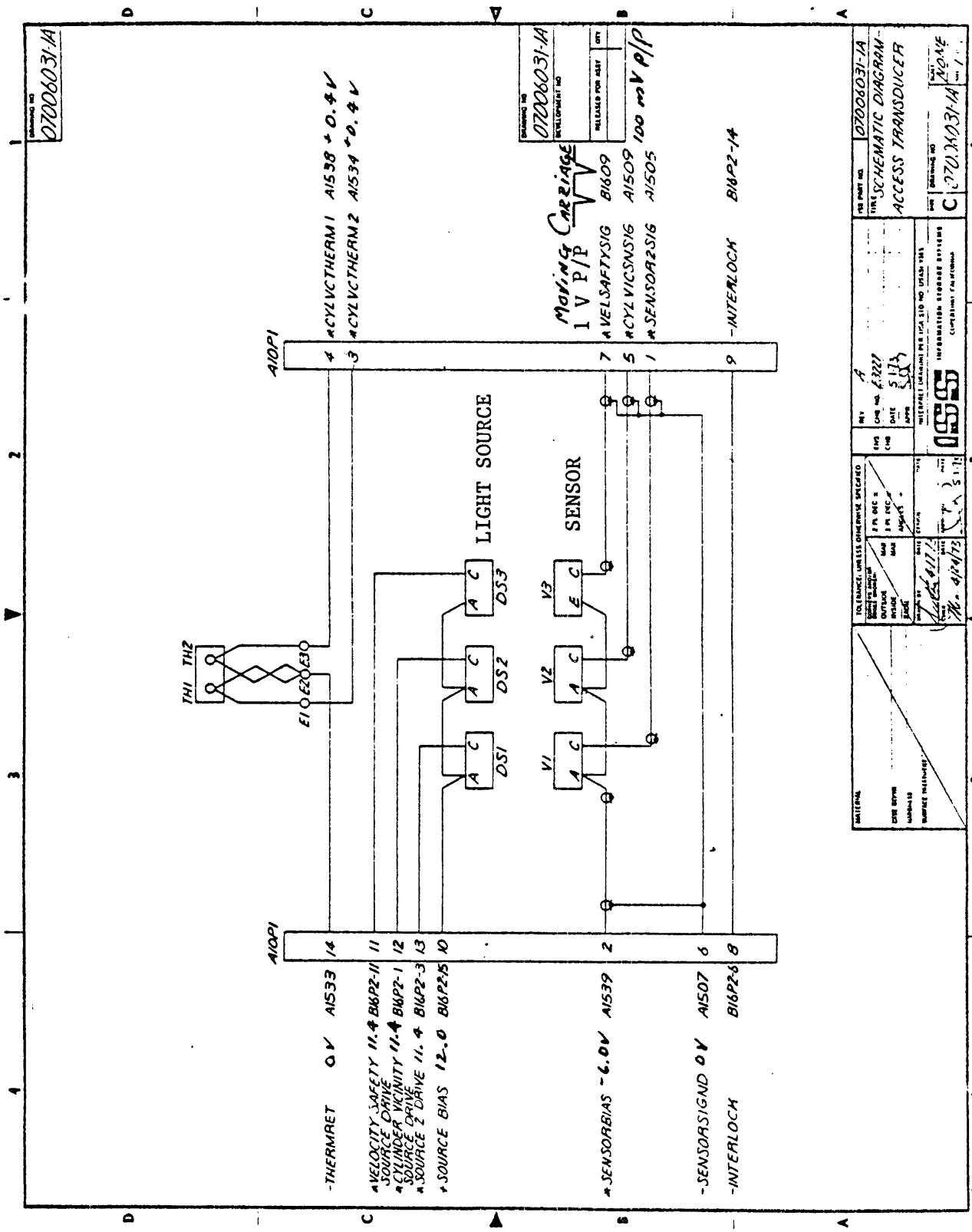

07006031-1A

07006031-1A
DEVELOPMENT NO
RELEASED FOR ASST ONY

NATIONAL CORE SYSTEMS LABORATORIES BURBANK, CALIFORNIA		TELEPHONE: UNLESS OTHERWISE SPECIFIED BURBANK: 818-251-1111 LOS ANGELES: 213-251-1111 WASHINGTON: 202-251-1111	
REV	CHG NO	DATE	BY
1	1	5/1/73	W. A. H. / J. S. H.
INFORMATION STORAGE SYSTEMS COMPLIANCE WITH FCIM, II, 1-2.4.2			
THE PART NO 07006031-1A		THE SCHEMATIC DIAGRAM ACCESS TRANSDUCER	
THE PART NO 07006031-1A		THE SCHEMATIC DIAGRAM ACCESS TRANSDUCER	

2511-1

REGISTER ACCESS ERROR ANALYSIS

BY: RICH CATENA

M.A.R. - REGIONAL SUPPORT

Do you have a hopeless feeling about the register access errors you've been getting? This article will show you how to get a lot more information about the problem and a starting point to fixing it.

Under TOPS-20 there are three BUGCHK's which may occur upon getting a register access error. They are:

P2RAE1
P2RAE2
P2RAE3

Each BUGCHK will be looked at individually with a step-by-step procedure for gathering all the information available.

P2RAE1:

A P2RAE1 occurs upon getting a register access error when trying to do a read of the register. A majority of the information available can be gotten by examining the SYSERR entry for the BUGCHK.

This is gotten by using the /DET and the /DEV:KLCPU switches to SYSERR. The information which is most useful in this entry is the content of the AC's. AC1 should contain the result of a DATAI from the RH20, AC2 should contain the CONI from the RH20 and the contents AC10 and AC12 will enable us to tell which RH and which unit on that RH were being used at the time. The additional data items listed at the end of the entry are just the contents of the AC1 and AC2. Now we will see how to find the channel and unit. You will need FILDDT, and an account on the system with wheel privileges. In the following procedure the underlined text was printed by the system.

COMMENT

```
@ RU FILDDT CR ; RUN FILDDT
FILDDT>LOAD PS:<SYSTEM>MONITOR.EXE<CR> ;LOAD SYMBOLS FROM MONITOR
```

```
FILDDT>PEEK<CR> ; WE WILL LOOK AT THE RUNNING MONITOR
403$U
CHNTAB/ RESFRD+7 = 555007<LF> ; HERE WE ARE LOOKING FOR THE ADDRESSES
OF THE CHANNEL
```

```
CHNTAB+1/RESFRP+250 = 555250 ; DATA BLOCKS FOR EACH CHANNEL CHNTAB
CONTAINS THE ADDRESS FOR CHANNEL 0,
CHNTAB+1 CONTAINS THE ADDRESS FOR
CHANNEL 1, ETC.
```

At this point, what you are looking for is a match between what you saw in AC10 in the SYSERR entry and the contents of CHNTAB, CHNTAB+1, or CHNTAB+2, etc. If AC10 had contained 555007 the first RH was being used; if AC10 had equaled what you found in CHNTAB+2 then the third RH was being used. When I refer to "1st RH" or "3rd RH" I mean the first or third RH installed. For example, if there is an RH20 in the channel 0 slots then CHNTAB will contain 555007, but if there is no RH in channel 0 and there is one in channel 1, CHNTAB will contain 0 indicating no RH in that slot and CHNTAB+1 will contain 555007 (in the sample SYSERR entry we were using the RH20 in channel 0). We will now find out which unit was being used. To do this, you must have identified which channel was being used.

$$555007 + \text{CDBUDB} / \text{RESFRD}+65 = \underline{555065} \langle \text{LF} \rangle$$

$$\text{RESFRP} + \text{XXX} / \text{RESFRD}+130 = \underline{555130} ;$$

These are the addresses of the unit data blocks for each unit on channel 0. We are looking for a match between the contents of AC12 and one of these locations. 555007 + CDBUDB contains the address of the UDB for unit 0, 555007 + CDBUDB + 1 contains the address of the UDB for unit 1, etc.

When you are done, you can control-C out of FILDDT. Using the above procedure, it is impossible to hurt the running monitor and you should be able to get all the information you need.

The procedure for a P2RAE2 is identical to that of the P2RAE1. In the SYSERR entry for a P2RAE3 the channel number is in AC3 and you don't have to use FILDDT.

The differences between the three BUGCHK's are:

P2RAE1 - ERROR OCCURRED UPON READING THE REGISTER.

P2RAE2 - ERROR OCCURRED UPON WRITING THE REGISTER.

P2RAE3 - ERROR OCCURRED DURING AN INTERRUPT FROM THE CHANNEL.

DATA IN P2RAE SYSERR ENTRIES		
<u>BUGCHK</u>	<u>AC</u>	<u>CONTENTS</u>
P2RAE1 (RAE DURING READ)	1	DATAI RH,
	2	CONI RH,
	10	CDB ADDRESS
	12	UDB ADDRESS
P2RAE2 (RAE DURING WRITE)	1	DATAI RH,
	2	CONI RH,
	10	CDB ADDRESS
	12	UDB ADDRESS
P2RAE3 (RAE DURING INTERRUPT)	1	DATAI RH,
	2	CONI RH,
	3	CHANNEL NUMBER

MODULE SWAPPING

BY: ANDERS FRISK

DISTRICT FIELD SERVICE - STOCKHOLM, SWEDEN

Most Engineers nowadays are using module swapping/rotating to locate failures (by swapping modules between halfwords - a failing bit in one halfword will instead show up in another halfword). This is normally a very good method as you will then also prove that it is the module that fails.

But you should remember what you are doing because there is a point where you might cause yourself and others some problems.

EXAMPLE:

Look at the E-Bus and C-Bus Translators. Diagnostics say that you have a problem with EBUS D27 (slot 4 pin AK2)--so you swap the modules around. The fault then moves to EBUS D15 (slot 5 pin AK2).

Great, the fault is located. You just have to replace the M8516 in slot 5 and everything will be okay. But...you should first move the other two modules back to their original slots (even though it takes a few extra seconds to do it).

Let's see what can happen if you don't:

You moved the module from:

Slot 4 to Slot 5
Slot 5 to Slot 6
Slot 6 to Slot 4

The module that was in slot 6 is now in slot 4. If you look at pin EK1, you will find that in slot 6, that was a spare (unused) circuit, whereas; in slot 4, it is CH CBUS RECEIVE ENABLE. i.e.: you have put an untested circuit into use. Same thing with CF2, slot 5 (spare) that went into slot 6 (EBUS CLK).

If the circuit is completely dead, it will probably cause you to think that the new module, that you were just going to put into slot 5, is dead (D.O.A.) or has some other problem. Anyhow, a good troubleshooting technique has ended with a bad result.

HOWEVER,

If the circuit is not completely dead, but is failing intermittently, you believe you have fixed the problem when indeed the problem will come back later.

Again, if you had put the modules back to their original slots this might have been avoided.

Take a look at the list of signals on the E-Bus and C-Bus Translators and you will find evidence that problems such as the one stated in the example (previous page) could happen.

Another point is when you receive a spare module and you are asked to test it during PM-time you should test it in all locations to really be able to say "it works". (M8516 and similar modules)

NOTE: THIS INFORMATION ALSO APPLIES TO:

- M8519 S-BUS TRANSLATOR
- M8558 KI MEMORY BUS ADAPTOR
- S-BUS CABLES

E-BUS and C-BUS Translator (M8516) chart on next page....

E-BUS AND C-BUS TRANSLATORS
M8516

COMPANY CONFIDENTIAL

R C W	P I N	SLOT 4			SLOT 5			SLOT 6			R O W	P I N	SLOT 4			SLOT 5			SLOT 6		
		SIGNAL NAME			SIGNAL NAME			SIGNAL NAME					SIGNAL NAME			SIGNAL NAME			SIGNAL NAME		
A	A1	EBUS DIAG STROBE	EBUS DS05	EBUS DS02	D	A1	GND	GND	GND	D	A1	GND	GND	GND	GND	GND	GND	GND	GND	GND	
	C1	EBUS DS06	EBUS DS03	EBUS DS00		C1	GND	GND	GND		C1	GND	GND	GND	GND	GND	GND	GND	GND	GND	
	C2	GND	GND	GND		C2	GND	GND	GND		C2	GND	GND	GND	GND	GND	GND	GND	GND	GND	
	D1	EBUS SPARE 34	EBUS DS04	EBUS DS01		D1	GND	GND	GND		D1	GND	GND	GND	GND	GND	GND	GND	GND	GND	
	D2	EBUS D31	EBUS D19	EBUS D07		D2	EBUS D35 E	EBUS D23 E	EBUS D11 E		E1	GND	GND	GND	GND	GND	GND	GND	GND	GND	
	E1	SPARE	EBUS PI07	EBUS PI03		E1	GND	GND	GND		E1	GND	GND	GND	GND	GND	GND	GND	GND	GND	
	E2	EBUS D32	EBUS D20	EBUS D08		E2	EBUS CS05 E	EBUS CS01 E	EBUS APR EBUS F01 E		E2	EBUS CS05 E	EBUS CS01 E	EBUS CS01 E	EBUS CS01 E	EBUS CS01 E	EBUS CS01 E	EBUS CS01 E	EBUS CS01 E	EBUS CS01 E	
	F1	EBUS SPARE 32	EBUS PI06	EBUS PI02		F1	GND	GND	GND		F1	GND	GND	GND	GND	GND	GND	GND	GND	GND	
	F2	EBUS D30	EBUS D18	EBUS D06		F2	EBUS CS04 E	EBUS CS00 E	EBUS F00 E		F2	EBUS CS04 E	EBUS CS00 E	EBUS CS00 E	EBUS CS00 E	EBUS CS00 E	EBUS CS00 E	EBUS CS00 E	EBUS CS00 E	EBUS CS00 E	
	H1	GND	GND	GND		H1	GND	GND	GND		H1	GND	GND	GND	GND	GND	GND	GND	GND	GND	
	H2	EBUS D29	EBUS D17	EBUS D05		H2	CLK EBUS RESET E	EBUS CS03 E	CTL CONSOLE CONTROL		H2	CLK EBUS RESET E	EBUS CS03 E	EBUS CS03 E	EBUS CS03 E	EBUS CS03 E	EBUS CS03 E	EBUS CS03 E	EBUS CS03 E	EBUS CS03 E	
	J1	PWR WARN	EBUS PI05	EBUS PI01		J1	GND	GND	GND		J1	GND	GND	GND	GND	GND	GND	GND	GND	GND	
	J2	EBUS D28	EBUS D16	EBUS D04		J2	EBUS CS06 E	EBUS CS02 E	EBUS F02 E		J2	EBUS CS06 E	EBUS CS02 E	EBUS CS02 E	EBUS CS02 E	EBUS CS02 E	EBUS CS02 E	EBUS CS02 E	EBUS CS02 E	EBUS CS02 E	
	K1	EBUS ACKN	EBUS PI04	EBUS PI00		K1	GND	GND	GND		K1	GND	GND	GND	GND	GND	GND	GND	GND	GND	
	K2	EBUS D27	EBUS D15	EBUS D03		K2	EBUS D34 E	EBUS D22 E	EBUS D10 E		K2	EBUS D34 E	EBUS D22 E	EBUS D22 E	EBUS D22 E	EBUS D22 E	EBUS D22 E	EBUS D22 E	EBUS D22 E	EBUS D22 E	
	L1	EBUS D33	EBUS D21	EBUS D09		L1	EBUS DONE E	EBUS START E	EBUS REQUEST E		L1	EBUS DONE E	EBUS START E	EBUS START E	EBUS START E	EBUS START E	EBUS START E	EBUS START E	EBUS START E	EBUS START E	
	L2	EBUS D26	EBUS D14	EBUS D02		L2	EBUS STORE E	EBUS RESET E	EBUS CTOM E		L2	EBUS STORE E	EBUS RESET E	EBUS RESET E	EBUS RESET E	EBUS RESET E	EBUS RESET E	EBUS RESET E	EBUS RESET E	EBUS RESET E	
	M1	EBUS D35	EBUS D23	EBUS D11		M1	EBUS LAST WORD E	EBUS SEL 6 E	EBUS SEL 2 E		M1	EBUS LAST WORD E	EBUS SEL 6 E	EBUS SEL 6 E	EBUS SEL 6 E	EBUS SEL 6 E	EBUS SEL 6 E	EBUS SEL 6 E	EBUS SEL 6 E	EBUS SEL 6 E	
	M2	EBUS D25	EBUS D13	EBUS D01		M2	EBUS SPARE 36 E	EBUS SEL 7 E	EBUS SEL 3 E		M2	EBUS SPARE 36 E	EBUS SEL 7 E	EBUS SEL 7 E	EBUS SEL 7 E	EBUS SEL 7 E	EBUS SEL 7 E	EBUS SEL 7 E	EBUS SEL 7 E	EBUS SEL 7 E	
	N1	EBUS D34	EBUS D22	EBUS D10		N1	GND	GND	GND		N1	GND	GND	GND	GND	GND	GND	GND	GND	GND	
	N2	GND	GND	GND		N2	GND	GND	GND		N2	GND	GND	GND	GND	GND	GND	GND	GND	GND	
	P1	EBUS CS05	EBUS CS01	EBUS F01		P1	EBUS READY E	EBUS SEL 5 E	EBUS SEL 1 E		P1	EBUS READY E	EBUS SEL 5 E	EBUS SEL 5 E	EBUS SEL 5 E	EBUS SEL 5 E	EBUS SEL 5 E	EBUS SEL 5 E	EBUS SEL 5 E	EBUS SEL 5 E	
	P2	EBUS D24	EBUS D12	EBUS D00		P2	EBUS ERROR E	EBUS SEL 4 E	EBUS SEL 0 E		P2	EBUS ERROR E	EBUS SEL 4 E	EBUS SEL 4 E	EBUS SEL 4 E	EBUS SEL 4 E	EBUS SEL 4 E	EBUS SEL 4 E	EBUS SEL 4 E	EBUS SEL 4 E	
	R1	EBUS CS04	EBUS CS00	EBUS F00		R1	EBUS D33 RE	EBUS D21 RE	EBUS D09 RE		R1	EBUS D33 RE	EBUS D21 RE	EBUS D21 RE	EBUS D21 RE	EBUS D21 RE	EBUS D21 RE	EBUS D21 RE	EBUS D21 RE	EBUS D21 RE	
	R2	EBUS SPARE 22	EBUS PARITY ACTIVE	EBUS PARITY		R2	EBUS D32 RE	EBUS D20 RE	EBUS D08 RE		R2	EBUS D32 RE	EBUS D20 RE	EBUS D20 RE	EBUS D20 RE	EBUS D20 RE	EBUS D20 RE	EBUS D20 RE	EBUS D20 RE	EBUS D20 RE	
	S1	EBUS CS06	EBUS CS02	EBUS F02		S1	EBUS SPARE 1 TE	EBUS PAR RIGHT TE	EBUS PAR LEFT TE		S1	EBUS SPARE 1 TE	EBUS PAR RIGHT TE	EBUS PAR RIGHT TE	EBUS PAR RIGHT TE	EBUS PAR RIGHT TE	EBUS PAR RIGHT TE	EBUS PAR RIGHT TE	EBUS PAR RIGHT TE	EBUS PAR RIGHT TE	
	S2	EBUS REM DS STATUS	EBUS REM DS STATUS	EBUS REMOVE DS STATUS		S2	EBUS SPARE 12 TE	EBUS SPARE 11 TE	EBUS SPARE 10 TE		S2	EBUS SPARE 12 TE	EBUS SPARE 11 TE	EBUS SPARE 11 TE	EBUS SPARE 11 TE	EBUS SPARE 11 TE	EBUS SPARE 11 TE	EBUS SPARE 11 TE	EBUS SPARE 11 TE	EBUS SPARE 11 TE	
	T1	GND	GND	GND		T1	GND	GND	GND		T1	GND	GND	GND	GND	GND	GND	GND	GND	GND	
	T2	EBUS SPARE 27	EBUS SPARE 26	EBUS DR SPLIT		T2	GND	GND	GND		T2	GND	GND	GND	GND	GND	GND	GND	GND	GND	
	U2	SPARE	SPARE	CROBAR		U2	EBUS D34 TE	EBUS D22 TE	EBUS D10 TE		U2	EBUS D34 TE	EBUS D22 TE	EBUS D22 TE	EBUS D22 TE	EBUS D22 TE	EBUS D22 TE	EBUS D22 TE	EBUS D22 TE	EBUS D22 TE	
A	V2	EBUS RESET	EBUS CS03	EBUS DATA DISABLE	D	V2	EBUS D33 TE	EBUS D21 TE	EBUS D09 TE	D	V2	EBUS D33 TE	EBUS D21 TE	EBUS D21 TE	EBUS D21 TE	EBUS D21 TE	EBUS D21 TE	EBUS D21 TE	EBUS D21 TE	EBUS D21 TE	
B	A1	SPARE	SPARE	EBUS XFER A	E	A1	EBUS D30 TE	EBUS D18 TE	EBUS D06 TE	E	A1	EBUS D30 TE	EBUS D18 TE	EBUS D18 TE	EBUS D18 TE	EBUS D18 TE	EBUS D18 TE	EBUS D18 TE	EBUS D18 TE	EBUS D18 TE	
	C1	SPARE E	SPARE E	EBUS XFER E		C1	EBUS D29 TE	EBUS D17 TE	EBUS D05 TE		C1	EBUS D29 TE	EBUS D17 TE	EBUS D17 TE	EBUS D17 TE	EBUS D17 TE	EBUS D17 TE	EBUS D17 TE	EBUS D17 TE	EBUS D17 TE	
	C2	GND	GND	GND		C2	GND	GND	GND		C2	GND	GND	GND	GND	GND	GND	GND	GND	GND	
	D1	SPARE	SPARE	EBUS CLK A		D1	EBUS D26 TE	EBUS D14 TE	EBUS D02 TE		D1	EBUS D26 TE	EBUS D14 TE	EBUS D14 TE	EBUS D14 TE	EBUS D14 TE	EBUS D14 TE	EBUS D14 TE	EBUS D14 TE	EBUS D14 TE	
	D2	EBUS SPARE 24 E	EBUS PAR ACTIVE E	EBUS PARITY E		D2	EBUS D27 TE	EBUS D15 TE	EBUS D03 TE		D2	EBUS D27 TE	EBUS D15 TE	EBUS D15 TE	EBUS D15 TE	EBUS D15 TE	EBUS D15 TE	EBUS D15 TE	EBUS D15 TE	EBUS D15 TE	
	E1	EBUS SPARE 8 E	EBUS 10/11 CLK A	EBUS DEMAND A		E1	EBUS D25 TE	EBUS D13 TE	EBUS D01 TE		E1	EBUS D25 TE	EBUS D13 TE	EBUS D13 TE	EBUS D13 TE	EBUS D13 TE	EBUS D13 TE	EBUS D13 TE	EBUS D13 TE	EBUS D13 TE	
	E2	EBUS SPARE 20 E	EBUS SPARE 19 E	CTL EBUS PARITY OUT E		E2	EBUS D24 TE	EBUS D12 TE	EBUS D00 TE		E2	EBUS D24 TE	EBUS D12 TE	EBUS D12 TE	EBUS D12 TE	EBUS D12 TE	EBUS D12 TE	EBUS D12 TE	EBUS D12 TE	EBUS D12 TE	
	F1	CTL EBUS SPARE 48	CTL EBUS SPARE 47	CTL EBUS SPARE 46		F1	EBUS D28 TE	EBUS D16 TE	EBUS D04 TE		F1	EBUS D28 TE	EBUS D16 TE	EBUS D16 TE	EBUS D16 TE	EBUS D16 TE	EBUS D16 TE	EBUS D16 TE	EBUS D16 TE	EBUS D16 TE	
	F2	EBUS D27 E	EBUS D15 E	EBUS D03 E		F2	EBUS D31 TE	EBUS D19 TE	EBUS D07 TE		F2	EBUS D31 TE	EBUS D19 TE	EBUS D19 TE	EBUS D19 TE	EBUS D19 TE	EBUS D19 TE	EBUS D19 TE	EBUS D19 TE	EBUS D19 TE	
	H1	GND	GND	GND		H1	GND	GND	GND		H1	GND	GND	GND	GND	GND	GND	GND	GND	GND	
	H2	GND	GND	GND		H2	GND	GND	GND		H2	GND	GND	GND	GND	GND	GND	GND	GND	GND	
	J1	CTL EBUS T TO E EN	CTL EBUS E TO T EN	CTL EBUS SPARE 44		J1	EBUS D25 RE	EBUS D13 RE	EBUS D01 RE		J1	EBUS D25 RE	EBUS D13 RE	EBUS D13 RE	EBUS D13 RE	EBUS D13 RE	EBUS D13 RE	EBUS D13 RE	EBUS D13 RE	EBUS D13 RE	
	J2	EBUS D26 E	EBUS D14 E	EBUS D02 E		J2	EBUS D24 RE	EBUS D12 RE	EBUS D00 RE		J2	EBUS D24 RE	EBUS D12 RE	EBUS D12 RE	EBUS D12 RE	EBUS D12 RE	EBUS D12 RE	EBUS D12 RE	EBUS D12 RE	EBUS D12 RE	
	K1	CH EBUS RECEIVE EN	SPARE	SPARE		K1	EBUS D26 RE	EBUS D14 RE	EBUS D02 RE		K1	EBUS D26 RE	EBUS D14 RE	EBUS D14 RE	EBUS D14 RE	EBUS D14 RE	EBUS D14 RE	EBUS D14 RE	EBUS D14 RE	EBUS D14 RE	
	K2	EBUS D31 E	EBUS D19 E	EBUS D07 E		K2	EBUS D27 RE	EBUS D15 RE	EBUS D03 RE		K2	EBUS D27 RE	EBUS D15 RE	EBUS D15 RE	EBUS D15 RE	EBUS D15 RE	EBUS D15 RE	EBUS D15 RE	EBUS D15 RE	EBUS D15 RE	
	L1	GND	GND	GND		L1	EBUS D29 RE	EBUS D17 RE	EBUS D05 RE		L1	EBUS D29 RE	EBUS D17 RE	EBUS D17 RE	EBUS D17 RE	EBUS D17 RE	EBUS D17 RE	EBUS D17 RE	EBUS D17 RE	EBUS D17 RE	
	L2	EBUS D30 E	EBUS D18 E	EBUS D06 E		L2	EBUS D28 RE	EBUS D16 RE	EBUS D04 RE		L2	EBUS D28 RE	EBUS D16 RE	EBUS D16 RE	EBUS D16 RE	EBUS D16 RE	EBUS D16 RE	EBUS D16 RE	EBUS D16 RE	EBUS D16 RE	
	M1	CTL EBUS E TO T EN	CTL EBUS E TO T EN	CTL EBUS E TO T EN		M1	EBUS D30 RE	EBUS D18 RE	EBUS D06 RE		M1	EBUS D30 RE	EBUS D18 RE	EBUS D18 RE	EBUS D18 RE	EBUS D18 RE	EBUS D18 RE	EBUS D18 RE	EBUS D18 RE	EBUS D18 RE	
	M2	EBUS D28 E	EBUS D16 E	EBUS D04 E		M2	EBUS D31 RE	EBUS D19 RE	EBUS D07 RE		M2	EBUS D31 RE	EBUS D19 RE	EBUS D19 RE	EBUS D19 RE	EBUS D19 RE	EBUS D19 RE	EBUS D19 RE	EBUS D19 RE	EBUS D19 RE	
	N1	GND	GND	GND		N1	GND	GND	GND		N1	GND	GND	GND	GND	GND	GND	GND	GND	GND	
	N2	GND	GND	GND		N2	GND	GND	GND		N2	GND	GND	GND	GND	GND	GND	GND	GND	GND	
	P1	GND	GND	GND		P1	EBUS D32 TE	EBUS D20 TE	EBUS D08 TE		P1	EBUS D32 TE	EBUS D20 TE	EBUS D20 TE	EBUS D20 TE	EBUS D20 TE	EBUS D20 TE	EBUS D20 TE	EBUS D20 TE	EBUS D20 TE	
	P2	EBUS D29 E	EBUS D17 E	EBUS D05 E		P2	EBUS D35 TE	EBUS D23 TE	EBUS D11 TE		P2	EBUS D35 TE	EBUS D23 TE	EBUS D23 TE	EBUS D23 TE	EBUS D23 TE	EBUS D23 TE	EBUS D23 TE	EBUS D23 TE	EBUS D23 TE	
	R1	GND	GND	GND		R1	EBUS D34 RE	EBUS D22 RE	EBUS D10 RE		R1	EBUS D34 RE	EBUS D22 RE	EBUS D22 RE	EBUS D22 RE	EBUS D22 RE	EBUS D22 RE	EBUS D22 RE	EBUS D22 RE	EBUS D22 RE	
	R2	EBUS D24 E	EBUS D12 E	EBUS D00 E		R2	EBUS D35 RE	EBUS D23 RE	EBUS D11 RE		R2	EBUS D35 RE	EBUS D23 RE	EBUS D23 RE	EBUS D23 RE	EBUS D23 RE	EBUS D23 RE	EBUS D23 RE	EBUS D23 RE	EBUS D23 RE	
	S1	SPARE	SPARE	CROBAR		S1	EBUS SPARE 15 RE	EBUS SPARE 14 RE	EBUS SPARE 13 RE		S1	EBUS SPARE 15 RE	EBUS SPARE 14 RE	EBUS SPARE 14 RE	EBUS SPARE 14 RE	EBUS SPARE 14 RE	EBUS SPARE 14 RE	EBUS SPARE 14 RE	EBUS SPARE 14 RE	EBUS SPARE 14 RE	
	S2	EBUS D25 E	EBUS D13 E	EBUS D01 E		S2	EBUS SPARE 2 RE	EBUS PAR RIGHT RE	EBUS PAR LEFT RE		S2	EBUS SPARE 2 RE	EBUS PAR RIGHT RE	EBUS PAR RIGHT RE	EBUS PAR RIGHT RE	EBUS PAR RIGHT RE	EBUS PAR RIGHT RE	EBUS PAR RIGHT RE	EBUS PAR RIGHT RE	EBUS PAR RIGHT RE	
	T1	GND	GND	GND		T1	GND	GND	GND		T1	GND	GND	GND	GND	GND	GND	GND	GND	GND	
	T2	SPARE E	SPARE E	CROBAR E		T2	GND	GND	GND		T2	GND	GND	GND	GND	GND	GND	GND	GND	GND	
	U2	GND	GND	GND		U2	EBUS DONE	EBUS START	EBUS REQUEST		U2	EBUS DONE	EBUS START	EBUS START	EBUS START	EBUS START	EBUS START	EBUS START	EBUS START	EBUS START	
B	V2	EBUS SPARE 31 E	EBUS SPARE																		

KL10 REVISION 12/4 STATUS UPDATE
BY: HERMAN MILLET
MAINTAINABILITY ENGINEERING GROUP

Hopefully by now you have had an opportunity to read through a copy of one of the Revision 12/4 FCO's. I also hope that you have followed our progress through the numerous articles that have appeared in GOOD STUFF over the last 12-months. A considerable effort has gone into the planning of this KL System Revision Change, but the most important time has finally come.

If you have not guessed by now, I must tell you that the success of this retrofit is extremely important. All of the goals of the retrofit can be summed up in saying that this retrofit will provide you with the most reliable hardware and diagnostics available on the KL10 today.

One part of the project involved conducting Seminars in every Area/Region to give individuals in each Region an opportunity to perform the backplane portion of the change. It is recommended that only those persons who attended one of these Seminars perform the backplane change.

Marlboro Manufacturing began shipping systems at Revision 4 in February of 1979. Shortly after that it was discovered that the new module revision of the M8556 has a problem. Therefore, an M8556 at module revision level "F" is no longer acceptable and the revision 12/4 module kits will contain M8556 modules either at module revision level "E" or "H".

In spite of the effort and as much as we wanted everything to take place smoothly, we have experienced some problems. There are two major problem areas that you should be aware of.

The first problem deals with the distribution of the FCO documentation kits (NOT THE MODULE KITS). The FCO kits, which contain the KLAD media, the FCO procedures, the print package update and wire (if required), were to be shipped to all Field Branches via a Forced Distribution System. These kits are either being misplaced or are not being recognized as revision 12/4 FCO kits when they arrive. I strongly recommend that if you have not received a kit for each system in your Branch, that you attempt to locate your kit. If you are unable to locate a kit then you should notify your Regional FCO Coordinator.

The second problem we have encountered deals with the KLAD20 UPDATE (NOT THE KLAD10 UPDATE). We now know the reason why there have been so many problems with this update of the KLAD20 and have some specific recommendations as to the procedures to follow to successfully accomplish the update. The reason for the problems can best be described as an increased sensitivity in DECSYSTEM 20's between the type of hardware (Model "A" or Model "B") and the operating system.

CONT. NEXT PAGE →

Therefore, if you have a KL10C, Model "A", DECSYSTEM 20, you should do the following:

1. Use the originally distributed FE tape 1 of 3 marked as follows:

KLAD20-L-3A-B, Part Number BB-F287M-DD

Please note that you were previously told to destroy this tape. DO NOT DESTROY THIS TAPE!!!

2. Obtain a copy of the customer's version of RSX20F floppies that support release 3A 2040/2050 systems.
3. Then follow the existing instructions as provided in the revision 12/4 FCO kit.

If you have a KL10E, Model "B", DECSYSTEM 20, you should do the following:

1. Obtain a copy of the new FE tape 1 of 3 marked as follows:

KLAD20-L-3A-C, Part Number BB-F287M-D1

This tape has been forced distributed to all Branches along with a memo from me dated: 9-August-79.

2. Substitute the new tape for the old and you now have a KLAD20 update for Model "B" DECSYSTEM 20's.
3. Then follow the existing instruction as provided in the revision 12/4 FCO kit.

The above mentioned KLAD20 problems have been communicated to the Field via TWX. However, it was not until recently that we had a handle on what the problems were and how to solve them.

If you read through the FCO document you will find that the installation of this change is divided into three phases. Please report completion of each phase to your Regional FCO Coordinator. The purpose for this is to track the status of the change throughout the Field and also to insure that when module kits become available, that the Region is providing the kit in locations that are ready for it. Note that your Regional Support Team is ready to assist you in the implementation of this revision change. Any questions regarding the implementation should be forwarded to your Regional Team.

Finally, I would ask that you follow the procedure in the FCO. Every detailed section of the FCO has a purpose, down to the last appendix which gives sample LARS forms. If you follow the procedures thoroughly and are aware of the problems noted here, I am sure your implementation of this revision change will be successful.

GOOD STUFF ON SPEED BULLETIN

BY: NANCIE MITCHELL
LSG SYSTEMS SUPPORT

The following chart shows where you can find Good Stuff issues (14 through 20) on Speed Bulletin.

Issue #	Speed Bulletin
14	#67 Jan. 11 '79
15	#72 Feb. 26 '79
16	#75 March 19 '79
17	#77 March 9 '79
18	#82 May 14 '79
19	#84 May 29 '79
20	#94 Aug. 13 '79

SOFTWARE

SUPPORT OF TOPS-10 VERSION 6.03

BY: BERNIE S. MIETH
SOFTWARE SERVICES - MARLBORO

Please be reminded that TOPS-10 Version 6.03 will become unsupported software as of 1-September-1979.

This will comply with our policy of discontinuing support of older Monitors, six months after a new release. (TOPS-10 Version 6.03A; released February 1979).

This article originally appeared in the Large Buffer - Vol. 475.



stuff

COMPANY CONFIDENTIAL

This document contains sensitive information which shall not be disclosed to personnel outside of Digital Equipment Corporation.

This Newsletter is meant as an information document. Its contents are not necessarily Company Policy. It's a means by which LCG Product Support can distribute some tidbits of information to you.

IN THIS ISSUE ...

●HARDWARE

- BROKEN J1 CONNECTORS - MF20 POWER SUPPLIES. Page 3
- TU45 TAPE CONTROL BOARD DOA RATE. Page 3
- MF20 MOS CLOCK DECODE Page 3
- SLOW TERMINAL RESPONSE. Page 4

●MISCELLANEOUS

- S/X BUS RECORDER. Page 6
- DIGITAL DECcharts Page 8
- NEW LABELING METHOD - P1 AND E1 SHIPMENTS Page 9
- DID WE REACH YOU? (KL10 MAINTENANCE GUIDE). Page 9

●SOFTWARE

- 2060 PATCHES FOR RELEASE 3A TGHA. Page 12
- KEEP ALIVE CEASED CRASHES Page 13

●SUPPLEMENTS:

- TGHA-I (CORRECTION)
- TU45 PHOTO PARTS INDEX
- SPD - TOPS-10 FOR DUAL KL10, VERSION 7.00,
DECsystem-10 OPERATING SYSTEM

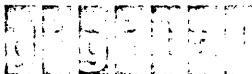

SEND ANY ARTICLES WHICH YOU FEEL SHOULD APPEAR IN GOOD STUFF
TO:

GOOD STUFF EDITORIAL OFFICE
c/o NANCIE MITCHELL
MR1-1/S35
DTN: 231-5148
TWX CODE: MR11

ANY FIELD SERVICE EMPLOYEE (700 cost centers only)
REQUESTING GOOD STUFF MUST SUBMIT A MEMO OR TWX TO:

SAME AS ABOVE

WITH THE FOLLOWING INFORMATION:

- NAME
- BADGE #
- COST CENTER
- LOCATION CODE

EDITOR Nigel Webb
ASSOC. EDITOR..Nancie Mitchell
EDITORIAL OFFICE.... MR1-1/S35

GOOD STUFF is published on a
monthly-basis.

BROKEN J1 CONNECTORS
MF20 POWER SUPPLIES
 BY: DON BROUILLET
 LCG/Q.E.

ARE YOU INVOLVED WITH MF20
 INSTALLATIONS? IF SO, PLEASE
 READ THE FOLLOWING INFORMATION:

Several AC/DC Power Supplies including one from the Field have been returned with broken J1 Logic Interface connectors. The breakage appears to be the result of misalignment while tightening the connectors and/or overtorque of the locking hardware.

Use of the following assembly should eliminate the problem:

1. Align the Logic Interface connector housing with the J1 receptacle on the AC/DC Power Supply.
2. Mate the two connectors by gradually pushing them together until they are flush with each other.
3. Lock the connectors together by turning both knurled lock screws at the same time. Do not fully tighten one lock screw before the other one is turned. This will cause the connector to twist and fracture.
4. Tighten the lock screws finger tight only.

DO NOT USE A SCREWDRIVER!!!!!!

TU45 TAPE CONTROL BOARD DOA RATE
 BY: LARRY BURKE
 LCG PRODUCT SUPPORT - MARLBORO

The DOA rate for 29-22296 (TU45 Tape Control) boards has gone sky high. The vast majority of these boards subsequently test okay.

If you install one of these boards and you cannot load tape, the board probably has one or several pots at an extreme position.

REFERENCE: PERTEC Manual - under troubleshooting.

MF20 MOS CLOCK DECODE
 BY: STU KENNEDY
 DDC/LCG

On the MF-20 MOS memory, to read which one of the KW-20 master oscillator clocks is selected, do a Function Read 134.

Bits 34 and 35 are decoded as follows:

<u>34</u>	<u>35</u>	
0	0	= KW 20 External Clock
0	1	= 31 MH (fast clock)
1	0	= 25 MH (slow clock)
1	1	= 30 MH (normal clock)

This Function Read is not described anywhere in the MF-20 Maintenance Manual nor in the latest copy of the KL Maintenance Guide.

SLOW TERMINAL RESPONSE

BY: MIKE HADAVI, JIM DAVIS, STU KENNEDY
 PK1/E33,SOMERSET, DDC/LCG

If your KL based DECSYSTEM-20 experiences an unusually slow terminal response, even at low load averages, the problem is most likely caused by excessive front-end interrupts from the DC20. These interrupts can be initiated by the Secondary Receive lines from either the dial-in lines, data-sets or the EIA type terminals. Since many asynchronous interfaces do not use the Secondary Receive line, it is left floating. As a result, for every character transmitted in either direction on a particular line a number of spikes may be picked up by that line's floating Secondary Receive line. Every spike, in turn, interrupts the front-end CPU at which point the front-end will report the interrupting line status to the KL. One possible symptom of the above situation is "TTYBBO" bugchk. Another way of detecting this situation is to examine the Big Buffer using the following sequence:

```
@ENA
$CONNECT PS:<SYSTEM>
$FILDDT
FILDDT>LOAD MONITR.EXE
FILDDT>PEEK

$$C
TTBBUF/ 12,,412      ;a line-feed from line 12
TTBBUF+1/ 4,,412    ;a line-feed from line 4
TTBBUF+2/ 4,,2004   ;an interrupt from line 4
TTBBUF+3/ 4,,2004   ;an interrupt from line 4
TTBBUF+4/ 4,,2004   ;an interrupt from line 4

^C                  ;back to the monitor
```

Normally, "2004" indicates that the carrier on line four made an "on" transition, but this is usually valid during the initial link establishment.

There are two solutions to this problem:

1. Disable interrupts from the Secondary Receive lines by removing the wire from the DC20 backplanes. (E02B1 to D02A1, refer to the DH11 Manual, Page 2-10). If there may be a future need for the Secondary Receive line, you can just ground it.

NOTE:

The above solution causes diagnostic DZDHM (test 60) to fail, also diagnostic DZDHK (test 107) fails. (You can jumper in the removed wire runs to overcome these diagnostic failures).

SLOW TERMINAL RESPONSE (cont.)

2. Disconnect pin 12 (Secondary Receive) in the 25 pin line connector, or connect pin 12 to pin 7 (ground). This would allow you to install the H315 turn-around jumper on any line without effecting the DH11 diagnostics.

NOTE:

This is the preferred solution, but you must label the cable/connector where the wiring is changed.

This problem cannot be overcome by patching RSX20F to ignore the interrupts from the Secondary Receive lines. The front-end still has to service an interrupt before realizing that the interrupt is from a Secondary Receive line.

S/X BUS RECORDER
BY: LARRY MIDURA
LSG SYSTEMS SUPPORT - MARLBORO

An S/X Bus Recorder has been developed by LSG Engineering that will detect and latch many problems associated with the KL10 SBUS.

Among the errors the recorder will be able to catch are:

1. Address Parity Error (including all address bits, request qualifiers, and parity bits).
2. Start A/B Error (start A and start B was detected simultaneously).
3. Parity Error (even parity was detected in SBUS data word during cycle).
4. Initial Start Error
 - a. RQ OX = ADR 34/35 - The SBUS request associated with SBUS address 34/35 was not asserted.
 - b. RMW = 1 wd rq - More than one word was requested on the SBUS for a read-modify-write cycle.
 - c. RD/WR RQ = 0 - No SBUS RD RQ or WR RQ asserted for a valid SBUS cycle.
5. DV/ACK Error - A data valid occurred before an ACKN.
6. DV Timeout - A missing data valid has been detected. Timeout is produced when the memory read access time (ACKN to DATA VALID) is exceeded.
7. ACK ERR - ACK "A" and ACK "B" were detected simultaneously.
8. DV ERR - DATA VALID "A" and DATA VALID "B" were detected simultaneously, or a DATA VALID was detected when RD RQ was not asserted.

CONT. NEXT PAGE →

S/X BUS RECORDER (cont.)

Along with stopping the recorder upon detection of one of the errors, there are 37(8) high speed rams which store 10 bits of previous SBUS activity as follows:

1. START "A" and START "B"
2. READ request and WRITE request
3. RQ0, RQ1, RQ2, RQ3
4. Address 34 and address 35

Testing and debugging of the recorder is currently going on with availability to the Field expected around 31 March 79.

The S/X Bus Recorder can be hooked up to any KL10 based system. This includes machines with DMA10, MA20/MB20, and MF20. Up to two SBUS recorders can be installed on a system. (SBUS 0 and SBUS 1)

The recorder is readable manually via switches, or through SBUS diagnostics.

If you would like to know any more information on the recorder, please contact:

LARRY MIDURA
C/O MR1-1/S35
DTN: 231-4257
PHONE: (617)-481-9511 EXT. 4257

NOTE: I would also like to know if you would like one.

DIGITAL DECcharts

BY: A.J. SCHMITT

FIELD SERVICE - CUSTOMER SERVICES - PK3-2/S29

This article (which originally appeared in Sales Update - Vol. 11 #4) details the new Digital DECchart flow diagramming forms developed by Logistics Information Systems. The advantages of the new DECcharts over existing charting materials, such as the IBM "Flowcharting Worksheet," are listed below for your information. The standard ISO/ANSI flowcharting templates can be used with the new DECcharts as they are equivalent in dimension.

It is hoped that use of the DECcharts will bring about significant savings in time and money, particularly in the areas of documentation, due to reduced processing procedures, as well as indirect benefits such as standardization in documentation.

DECchartsIBM Flowcharting Worksheets

- | | |
|---|--|
| 1. Compatible with standard ISO/ANSI templates | 1. Non-compatible with any industry standard template |
| 2. Form is printed in non-reproducible blue, which disappears when photocopied, leaving only the applicable data. | 2. Form is printed in regular ink and produces a clutter when copied |
| 3. Sheet size - 8 1/2" x 11" | 3. Sheet size - 11" x 16" |
| 4. Fits photocopy machine for reproducing. | 4. Must be folded twice to accommodate the physical limitations of a photocopy scanner. |
| 5. Direct one-to-one reproduction on photocopy paper or transparency. | 5. Has to be photo-reduced by three (for 8 1/2" by 11" output), and the output is small and difficult to read on paper and transparency. |
| 6. Direct to an acceptable final document. | 6. Several processes to final document. |
| 7. Pre-punched for two-hole and three-hole binders. | 7. Three hole punched. |
| 8. Fits standard two-hole and three-hole binders. | 8. Has to be folded to fit binder. |
| 9. Page number in upper right-hand corner for easy reference. | 9. Page number is difficult to reference. |

CONT. NEXT PAGE →

DIGITAL DECcharts (cont.)

DECcharts on next two pages →

- | | |
|---|--|
| 10. Form design is coordinated with typewriter spacing, both horizontally and vertically. | 10. Not typewriter oriented. |
| 11. More applicable titling. | 11. Restricted titling. |
| 12. Good block numbering convention. | 12. Difficult numbering convention. |
| 13. Chart is vertically oriented. | 13. Chart is horizontally oriented. |
| 14. Bold orientation "TIC" marks and lines facilitate use of template. | 14. Thin/small orientation marks and lines retard use of template. |

The new "DECchart" should be available at this time, Form Number EN-01095-15-N779(7PV).

NEW LABELING METHOD
P1 AND E1 SHIPMENTS

BY: MATERIAL CONTROL - LOGISTICS

The Material Control Packing Department in Woburn has initiated a new method of labeling P1 and E1 shipments.

All P1 shipments are taped in yellow. All E1 shipments are taped in green. This color distinction should help the Traffic Department, the carrier, and Customers in expediting Priority shipments.

NOTE: This information originally appeared in COD NOTES 9/79.

DID WE REACH YOU?

BY: LOU NAY

MAINTAINABILITY ENGINEERING
MARLBORO

If you are a holder of the KL10 Maintenance Guide (EK-OKL10-MG), you should have received a copy of the first update package.

This update is very recognizable as it contained a slip-case (box) to protect the two-volume Maintenance Guide. (Recent subscribers will have received the update coincident with their Maintenance Guide).

In the event you or others in your office have not yet received the update, send your name, badge number, cost center, and location to:

LOU NAY
MR1-1/S35

digital

DECchart

Analyst _____ Date _____ Page _____

System _____ Subsystem _____

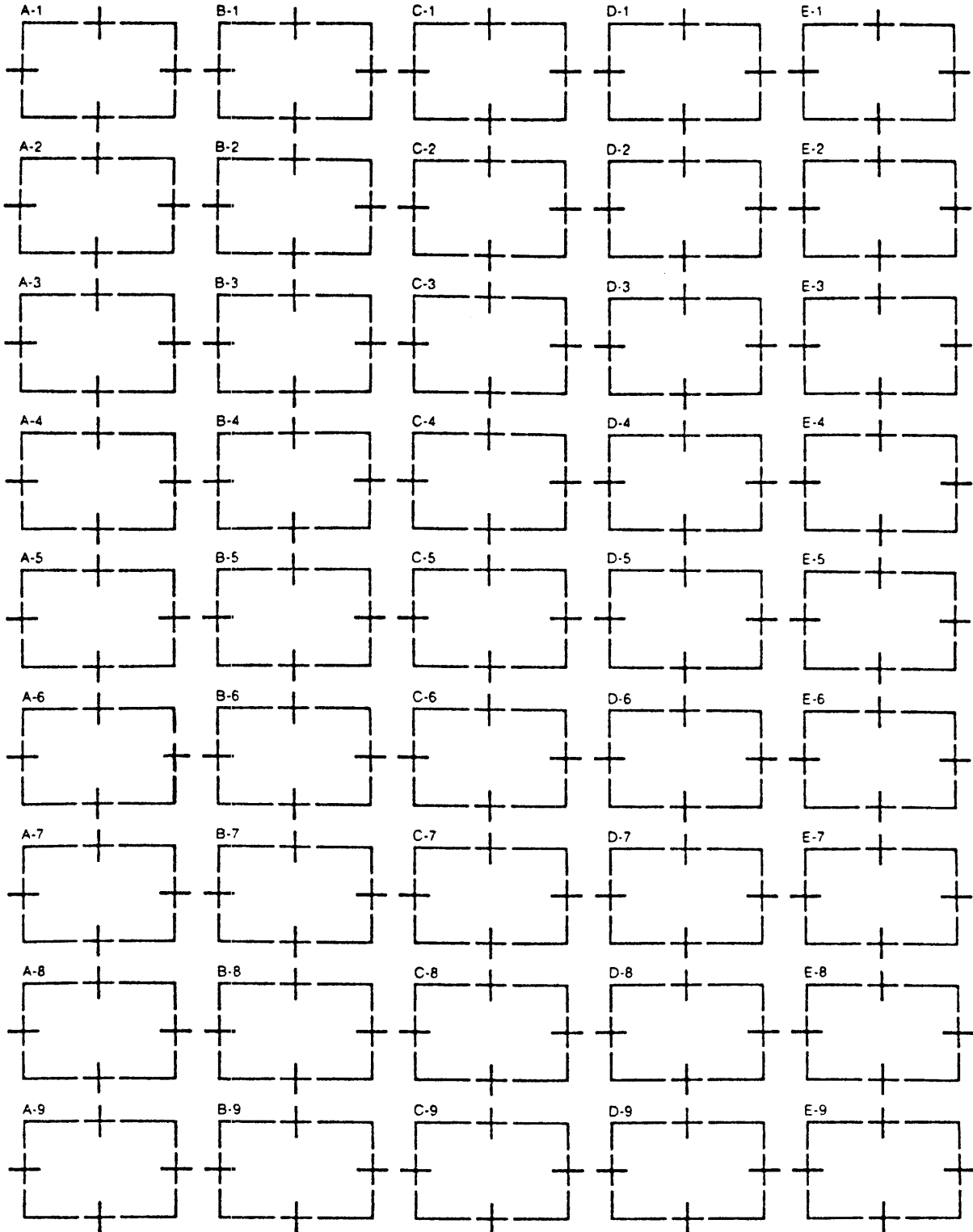

COPYRIGHT © 1979 DIGITAL EQUIPMENT CORPORATION



DECchart

Analyst A. J. SCHMITT

Date 6-13-79 Page 24

System ORDER PROCESSING

Subsystem NEW PRODUCTS

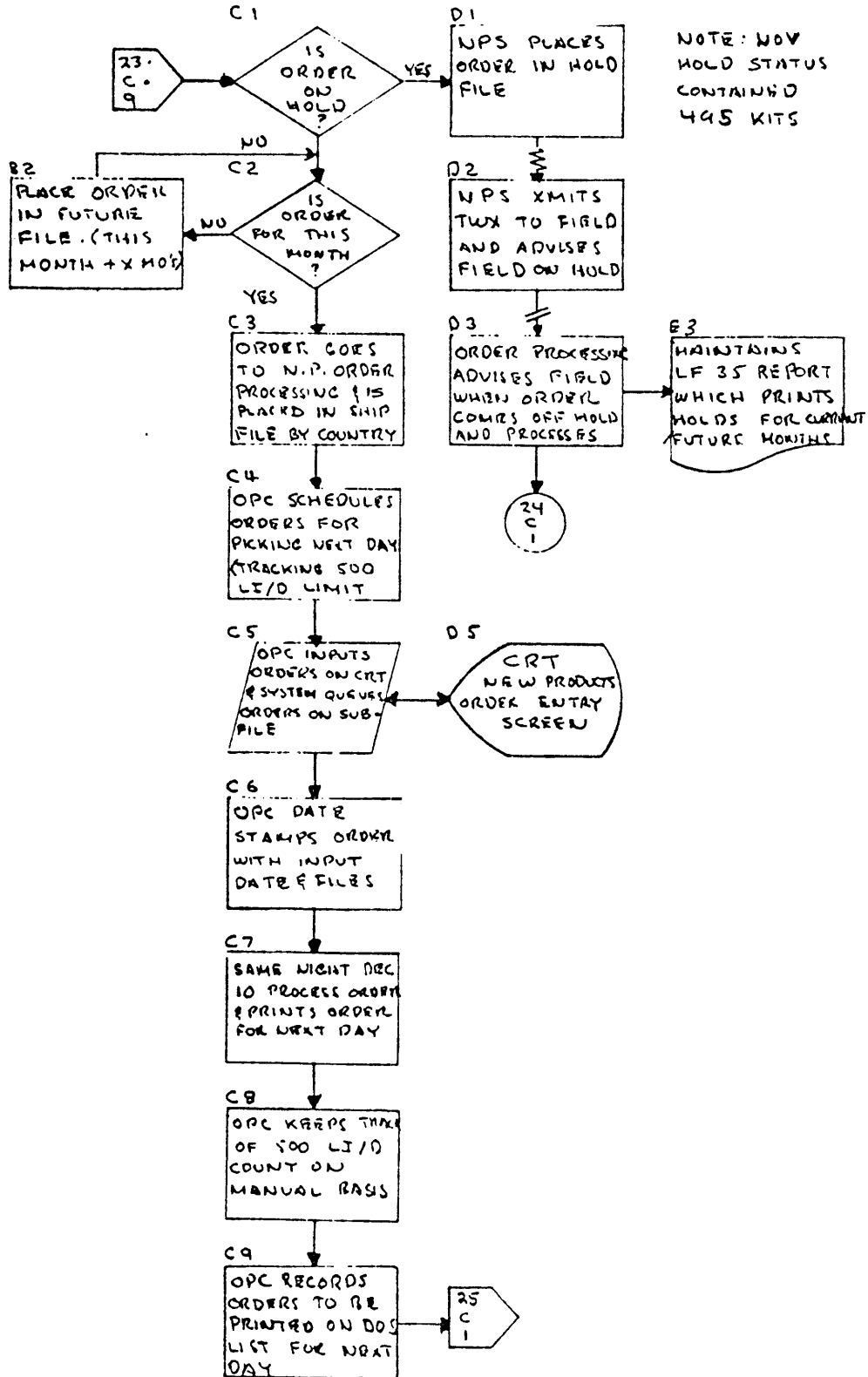

2060 PATCHES FOR RELEASE 3A

T G H A

BY: GENE YONCHAK
M.E.G. - MARLBORO

Update tape BB-H988A-BM containing a patch to support MF20 MOS on Release 3A software has an error on it that can cause memory some problems if the control file is submitted to batch.

The error is in the third line where the file runs DDT.

Change this from @DDT to @ST 140.

Example of old control file:

```
;CONTROL FILE TO PATCH TOPS-20 3A FOR USE WITH TGHA
@GET SYSTEM:MONITR.EXE
@DDT
PMCRM2/LDB T1,FFF44002,,0
FFF:
```

etc...

Example of correct control file:

```
;CONTROL FILE TO PATCH TOPS-20 FOR USE WITH TGHA
@GET SYSTEM:MONITR.EXE
@ST 140
PMCRM2/LBT T1,FFF44002,,0^JFFF:
```

etc...

IN ADDITION TO THE ABOVE CORRECTION TO THE CONTROL FILE, WE STRONGLY RECOMMEND THAT THE FILE BE EDITED SO THAT THE NEW PATCHED MONITR.EXE IS SAVED IN A DIRECTORY OTHER THAN SYSTEM.

IN THE EVENT THAT THE PATCH FAILED, THE OLD MONITR.EXE WILL STILL BE AVAILABLE.

EXAMPLE:

```
@SAVE <NEW-SYSTEM>MONITR.EXE
```

PLEASE NOTE: A new patch tape with corrections has been submitted to the Software Distribution Center (SDC).

KEEP ALIVE CEASED CRASHES
BY: CLIFF ROMASH
NER PRODUCT SUPPORT - WALTHAM

Recently, I've been involved with a large number of KL10's crashing with "Keep Alive Ceased" errors. It is very important to understand how to correctly gather data on these crashes because it is usually necessary to look at a system dump of a crash to determine what's wrong.

First, it should be understood that all "Keep Alive Ceased" means is that the monitor (either TOPS10 or TOPS20) stopped updating a counter that the eleven looks at, but did not halt. Usually, this means that it went into a loop of some sort. Note that this can be caused by either Hardware or Software.

On either TOPS10 or TOPS20, the first thing to do is inhibit auto reload by using the SET NO RELOAD command to PARSER. Then, when you get a crash, do a REPEAT 20:EXAMINE PC followed by an EXAMINE KL. This should get enough PC's to determine the loop and also get the status of the PI System.

On TOPS10, try depositing any non-zero number into location 30 (DEPOSIT 30:-1). If this does not get you to BOOTS, try a J 407 (i.e.: start the machine at 407). If this fails, do a HALT, then get BOOTS via KLI. In any case, when you get to BOOTS be sure to do a /D to dump the crash.

On TOPS20, you should halt the machine (HALT). Then examine the AC's [EXAMINE 0 followed by REPEAT 15 (EXAMINE NEXT)]. Now get BOOTS via KLI and be sure to do a /D.

IT IS VERY IMPORTANT TO COLLECT THIS INFORMATION, SINCE WITHOUT IT EVEN A WIZARD CAN ONLY GUESS WHAT CAUSED THE SYSTEM TO CRASH.

stuff

COMPANY CONFIDENTIAL

This document contains sensitive information which shall not be disclosed to personnel outside of Digital Equipment Corporation.

This Newsletter is meant as an information document. Its contents are not necessarily Company Policy. It's a means by which LCG Product Support can distribute some tidbits of information to you.

IN THIS ISSUE ...

PREREQUISITE FOR INSTALLING TOPS-20 VERSION 4.0.Page 14

●DIAGNOSTICS

- REVISION 12/4 "B" STRING PROBLEMSPage 3
- 2020 USER MODE DISK DIAGNOSTICSPage 3

●HARDWARE

- TX02 AND TX01 SPAR TAPES.Page 4
- MOS MEMORY INSTALLATION PROBLEMS.Page 5
- M8619 REVISION D (UBA MODULES).Page 5
- LP05/06/14 DAVFU PROBLEM.Page 6
- ANOTHER TU45 SERVO PROBLEM.Page 7
- KL10 PRINT M8552-0-DPS1 - ERRORPage 8

●KLAD

- HOW TO PATCH .A10 FILES ON KLAD10 PACKSPage 9

●MISCELLANEOUS

- WITS END.Page 13
- "NICE TO KNOW" INFORMATION.Page 13
- GOOD STUFF - BACK ISSUES.Page 13

●SOFTWARE

- PREREQUISITE FOR INSTALLING TOPS-20 VERSION 4.0Page 14
- RSX20F AUTO-BAUD DETECT IN TOPS-20 RELEASE 3APage 14
- THE 72 HOUR BUGPage 15
- PROCEDURE FOR BOOTING SYSTEM FROM TERMINAL
OTHER THAN CONSOLE.Page 16

●SUPPLEMENTS:

- WITS END
- TROUBLESHOOTING AIDS AND RESOURCES

SEND ANY ARTICLES WHICH YOU FEEL SHOULD APPEAR IN GOOD STUFF
TO:

GOOD STUFF EDITORIAL OFFICE
c/o NANCIE MITCHELL
MR1-1/S35
DTN: 231-5148
TWX CODE: MR11

ANY FIELD SERVICE EMPLOYEE (700 cost centers only)
REQUESTING GOOD STUFF MUST SUBMIT A MEMO OR TWX TO:

SAME AS ABOVE

WITH THE FOLLOWING INFORMATION:

- NAME
- BADGE #
- COST CENTER
- LOCATION CODE

EDITOR Nigel Webb
ASSOC. EDITOR..Nancie Mitchell
EDITORIAL OFFICE.... MR1-1/S35

GOOD STUFF is published on a
monthly-basis.

2020 USER MODE DISK DIAGNOSTICS

BY: LARRY KRAL

DDC/LCG

REVISION 12/4 "B" STRING PROBLEMS

BY: GENE YONCHAK

M.E.G.

Several sites have reported problems when running the "B" string immediately after completing the installation of Revision 12/4 FCO. After investigating this problem, we discovered that a large number of field people are using an early edit of Version 16 of KLDCP available on some input media (Dec-Tape, or floppy) other than the RH11/RP disk; that does not support the "B" string command file on the latest release KLAD packs. As a result, the "B" string may fail as soon as KLDCP tries to execute the "IT" command.

Please be aware that the latest version of KLDCP (Version 17) is installed on the most recent release KLAD10 and KLAD20 systems, as well as the klad update kits. It is this version that should be used when verifying "B" string operations after the completion of Revision 12/4.

It has been found that on a 2020, user mode disk diagnostics don't seem to run properly. This type of diagnostic is not supported or even designed to run under user mode, although the diagnostics give the impression that they do run since they give the user the system type and operating system type when they start.

The problem professes itself when the unit number question, in DSRMB, is repeated continuously.

TX02 AND TX01 SPAR TAPES

BY: PETE BERRY
M.E.G. - MARLBORO

Today there is but one 29 class number pointing to a STC SPAR tape and unfortunately that is not correct. 29-22706 appears on the TX02 RSL and is described on the Logistics PIC as a TX02 part, but in reality is a SPAR tape for a TX01. (29-22706 equals vendor part number 50055124).

The following is in the works to clear up this problem:

1. I have requested a new 29 class number be assigned to the TX01 SPAR kit (this will include the tape and the manual).
2. To obsolete the present 29 class number once the present stock is used up. If you need just a TX01 tape,

PLEASE

order it using the 29-22706 number.

3. TX02 SPAR tapes should be ordered using the STC part number until the pending FCO (new release of SPAR for TX02) is available (May 1980) to retrofit the field.

If anyone does have a need for a new TX02 tape before they are available via the FCO process, please contact:

Pete Berry - MR1-1/S35, 231-4457

or

Larry Burke - MR1-1/S35, 231-6337

for either a tape (at the present release) or the STC part number for the new release.

MOS MEMORY INSTALLATION PROBLEMS

BY: GENE YONCHAK
M.E.G. - MARLBORO

Incoming inspection has identified a problem relating to the MF20 MOS Memory power supply.

BE AWARE OF THIS PROBLEM

The problem deals with the H7131 power supply margin sense connector "J1". This is a "Winchester" type connector that contains two knurled screws that are slotted to receive a wide-blade screwdriver. Unfortunately, the nylon housing on the winchester connector will not survive the excessive torque if a screwdriver is used to tighten this connector.

When installing an MF20 add-on, or replacing the H7131 power supply, tighten this winchester connector finger tight, turning both screws at the same time, with equal pressure. Do not use any type of screwdriver.

NOTE: Future variations of this connector will not contain slotted screws.

M8619 REVISION D (UBA MODULES)

BY: JOE HOLEWA
M.E.G. - MARLBORO

The new etch M8619 modules have a different connector layout than previous revisions for that module. The new UBA module (M8619 Revision D) berg connectors are designated as J3-J2-J1 from the top of the module to the bottom of the module. The connectors for the previous revisions of that module were designated as J2-J1-J3, respectively. So if a UBA module goes bad and you replace it with an M8619 Revision D, make sure you connect the correct cable (the cables are numerically marked in Marlboro before shipment) to the corresponding berg connector.

NOTE: The M8619 Revision D module is KS10 Revision 2 and Revision 3 compatible.

LP05/06/14 DAVFU PROBLEM
BY: JIM CANNING
FIELD SERVICE - INDIANAPOLIS

When replacing the old DAVFU with the new PVFU (see chart below) the cable which plugged into "J2" of the old DAVFU now connects to "J3" of the new PVFU.

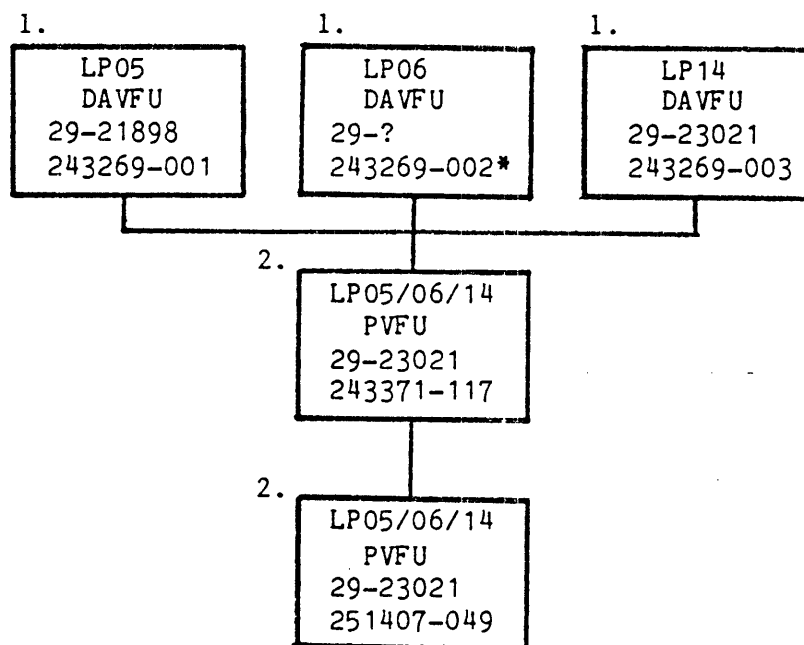

* The Vendor Part Number shown on the LP06 RSL was 243269-001. It should have been 243269-002.

1. The old DAVFU, DEC Part Number 29-21898 and Vendor Part Number 243269-XXX, have been discontinued and are no longer available.
2. Both PVFU, Vendor Part Number's 243371-117 and 251407-049 are cross-compatible and interchangeable.

ANOTHER TU45 SERVO PROBLEM
BY: WALTER WRIGHT
IN HOUSE FIELD SERVICE - MARLBORO

Recently, a problem was encountered on a TU45 that intermittently dropped vacuum. It didn't matter whether the tape was moving or stationary.

The problem turned out to be on the power supply (G1) module. There is an 800 HZ free-running oscillator on this module which interacts with the pick-ups on the reel tachs. If the oscillator frequency changes, it tricks the reel motors into thinking its' reel tachometers have moved.

If you experience the conditions listed below, monitor the 800 HZ oscillator with tape loaded and positioned in the park zone. The signal should remain steady with no variation in frequency. If the signal is out of specification, replace the power supply module.

SYMPTOMS:

- Both reels move when the tape is positioned in park zone.
- Reels spin causing interlock to break, but the capstan never moves.

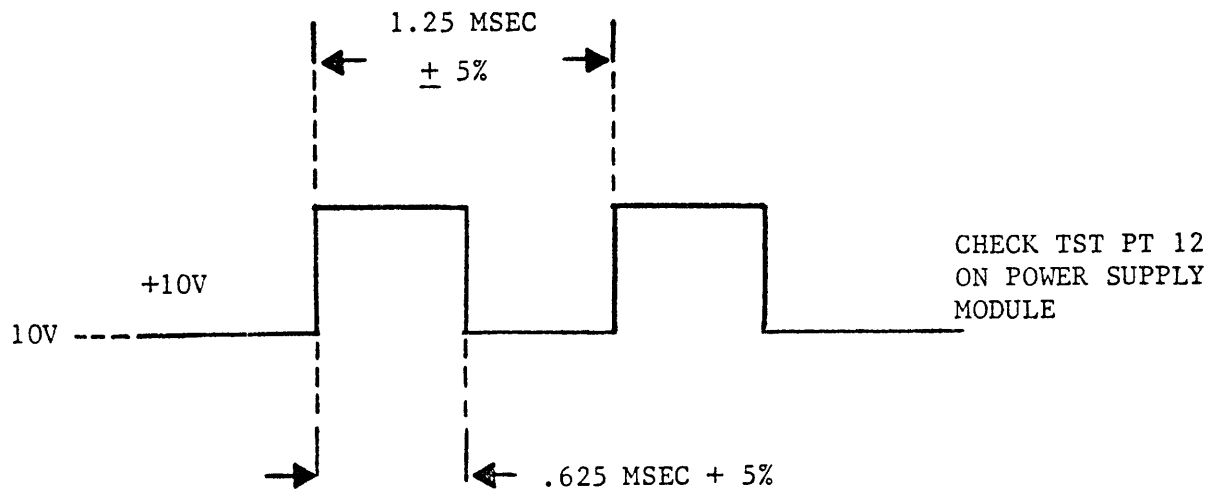

KL10 PRINT M8552-0-DPS1

E R R O R

BY: RUSS MYERS

KANATA

An error exists in the KL10 print set for the DTE20. The error is on print M8552-0-DPS1 for Revision "A" or "C" drawings. The Revision "B" or "B1" drawing is correct. The signals on pins DP2 and DM2 should be reversed on the Revision "A" and "C" drawings.

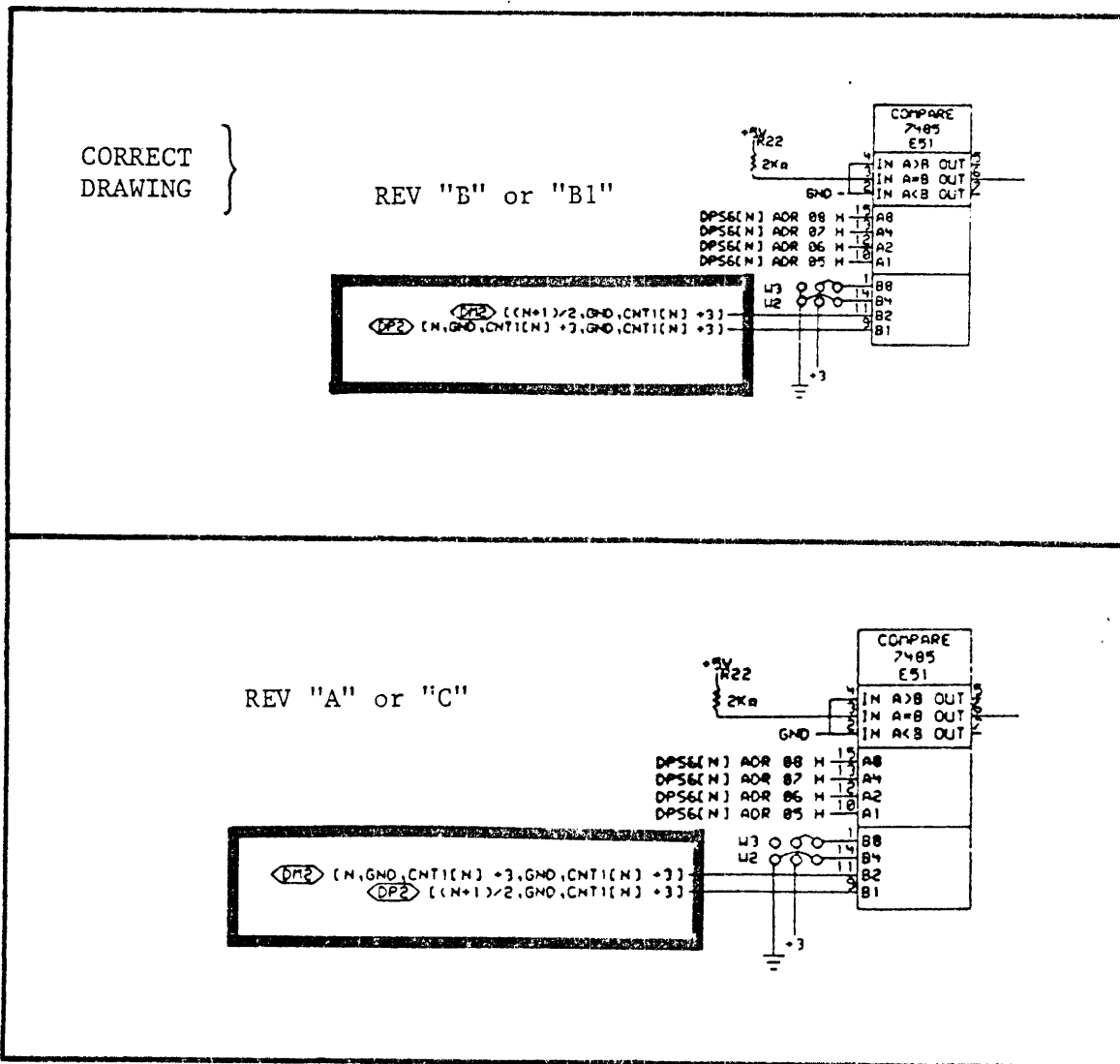

HOW TO PATCH .A10 FILES ON KLAD10 PACKS

BY: DAVID ROBERT
 DIAGNOSTIC ENGINEERING - MARLBORO

Follow the procedure for loading the system in KLAD10.MEM page 7.
 Do all of the instructions including logging in the [6,10] area.
 Then follow the instructions listed below:

RUN CONVRT.SAV

CONVRT - DECSYSTEM DIAGNOSTIC ASCIIZER CONVERSION PROGRAM [DDQDG]
 VERSION 000.014

TYPE /H<CR> FOR HELP
 FILE: /H

COMMANDS TERMINATE WITH <CR>
 COMMAND IS FILE.EXT/SWITCH

PDP-10 'EXT' DEFAULT IS 'SAV'
 PDP-11 'EXT' DEFAULT IS 'BIN'
 PDP-8 'EXT' DEFAULT IS 'BIN'
 DX20 'EXT' DEFAULT IS 'BIN'
 KMC11 'EXT' DEFAULT IS 'BIN'
 MICRO 'EXT' DEFAULT IS 'MCR'

<u>COMMAND</u>	<u>FUNCTION</u>
FILE	PDP-10 SAVE FILE TO ASCII '.A10' CONVERSION
FILE/T	" DEFAULT
FILE/A	PDP-10 SAVE FILE TO "SUPER" '.A10' CONVERSION
FILE/S	PDP-10 '.A10' FILE BACK TO '.SAV' CONVERSION
FILE/E	PDP-11 BINARY FILE TO ASCII '.A11' CONVERSION
FILE/8	PDP-8 BINARY FILE TO ASCII '.A8' CONVERSION
FILE/X	DX20 BINARY FILE TO ASCII '.ADX' CONVERSION
FILE/C	KMC11 BINARY FILE TO ASCII '.KMC' CONVERSION
FILE/F	MINNOW DEBUG MICRO-CODE LISTING TO '.RAM' CONVERSION
FILE/K	KS-10 MICRO-CODE LISTING TO '.RAM' CONVERSION
FILE/M	MICRO-CODE LISTING TO ASCII '.RAM' CONVERSION
FILE/R	MICRO RAM FILE ONLY, NO LISTING
/N	DON'T PRINT MICRO CODE ERRORS
/H	THIS MESSAGE

YOU HAVE TO CONVERT THE .A10 PROGRAM TO .SAV FORMAT SO YOU CAN
 PATCH THE PROGRAM.

CONT. NEXT 3 PAGES →

FILE:DDQCB.A10/S

CONVERTING COMPLETED, INPUT BLOCKS = 282, OUTPUT BLOCKS = 155

EXIT

.GET DDQCB.SAV

JOB SETUP

YOU ARE NOW INSERTING THE PATCH.

.DDT

VMDDT

40167/ LSH 2,-1 =242100,,777777 240100,,777774

40170/ TLO 2,400000 =661100,,400000 603100,,17

40171/ ASH 2,-3 =240100,,777775 240100,,4

PRESS CTRL 'C'

YOU ARE NOW SAVING THE PROGRAM THAT YOU HAVE JUST PATCHED.

.OSAV DDQCB.SAV

DDQCB SAVED

YOU NOW HAVE TO CONVERT THE .SAV PROGRAM THAT YOU PATCHED BACK TO AN .A10 PROGRAM.

.RUN CONVRT.SAV

CONVRT - DECSYSTEM DIAGNOSTIC ASCIIIZER CONVERSION PROGRAM [DDQDG]

TYPE /H<CR> FOR HELP

FILE:DDQCB.SAV

CONVERTING COMPLETED, INPUT BLOCKS = 166, OUTPUT BLOCKS = 344

EXIT

.DIR DDQCB.*

DDQCB A10 334 <055> 12-OCT-79 KLAD: [6,10]

DDQCB SAV 166 <057> 12-OCT-79 (7)

TOTAL OF 500 BLOCKS IN TWO FILES ON KLAD: [6,10]

NOW DELETE THE .SAV PROGRAM THAT YOU USED. YOU DO NOT NEED THIS ANYMORE.

.DEL DDQCB.SAV

FILES DELETED:
DDQCB.SAV
166 BLOCKS FREED

.K/F

YOU ARE NOW GOING TO CHECK TO MAKE SURE THAT THE PATCH YOU PUT
INTO THE PROGRAM IS THERE, USING DDT.

PRESS CTRL '\'

PAR>SET CON MAI

CONSOLE MODE: MAINTENANCE
PRESS CTRL '\'

PAR%SH OR AB

PRESS CTRL '\'

PAR%M BOO

BOO>DBOOT

DECSYSTEM DIAGNOSTIC CONSOLE
VERSION 0.17
SWR = 000203 DTE # 0
CMD:
>.P DIAMON

>.STL

>.

* DIAMON [DDQDC] - DECSYSTEM DIAGNOSTIC MONITOR - VERSION 0.14*

DEV:T,K,D,V,P - P

DISK:[P,PN] - [6,11]

DISK:[P,PN] - 0

DISK:[P,PN] - [6,10]

DIAMON CMD - DDQCB\$

>. STM

>.

DDQCB-F MEMORY PORT INTERACTION / SYSTEM EXERCISER

CMD:

>. DDT

>. DDT

40167/ ASH 2,-4 =240100,,777774

40170/ TLNE 2,P =603100,,17

40171/ ASH 2,4 =240100,,4

PRESS CTRL 'C'

CMD:

>.

WITS END
 BY: NANCIE MITCHELL
 LSG SYSTEMS SUPPORT

You can now order additional copies of WITS END through Printing and Circulation Services - Northboro.

To order, send a TWX to:

PRINTING AND CIRCULATION SERVICES
 NR2-2/M15
 Twx Code: NR12

with the following information:

1. Requestor's Name:
2. Badge #:
3. Cost Center:
4. Location:
5. Part #: EJ-90870-18
6. Publication Name: WITS END
7. Quantity:

Cross Reference:

An explanation of Group Codes (Sales) was published in Sales Update - Volume 10 - Cumulative Index. You might find them useful.

"NICE TO KNOW" INFORMATION

- TROUBLESHOOTING AIDS AND RESOURCES - published with this issue of Good Stuff.

CONTENTS: Phone Numbers, locations, contacts, and services provided, by the various support groups within Digital.

- TOPS-10 SOFTWARE PUBLICATIONS - published in the Large Buffer, Volume 485, 8-November-79.

CONTENTS: Software Documentation manuals for the TOPS-10 Operating system.

GOOD STUFF - BACK ISSUES

BY: NANCIE MITCHELL
 LSG SYSTEMS SUPPORT

I am being flooded with requests for back issues of Good Stuff. Therefore, I am finding it very difficult to respond to these requests.

If there is any way you can get copies of Good Stuff from someone in your office--get them. If you don't have any access to back issues send me a TWX or memo and I will either send you copies or direct you to someone in your Branch/District/Region who does receive Good Stuff.

Thanks.

PREREQUISITE FOR INSTALLING
TOPS-20 VERSION 4.0

BY: SEAN KEENAN
MARLBORO SOFTWARE MAINTAINABILITY
ENGINEERING

Because of extensive changes to the terminal handling code in V4.0 of TOPS-20, FCO 20FE-R-0001 must be installed in all DECSYSTEM-20's before V4.0 can run. This is a required FCO released in February 1979.

The FCO places a DB11-A bus repeater in the first system unit slot of the expansion box in the front end. Please check and be sure that the FCO is installed and a DB11-A is already in the first system unit.

If you require this FCO, contact your Regional FCO Coordinator immediately (EQ-00920-00).

AGAIN, TOPS-20 V4.0 WILL NOT RUN
WITHOUT THE FCO INSTALLED.

PLEASE READ

* I M P O R T A N T *

RSX20F AUTO-BAUD DETECT IN
TOPS-20 RELEASE 3A
BY: BOBBIN TEEGARDEN

This article addresses two issues:

1. Non 300 baud lines getting reset to 300 baud due to spurious line noise.

and

2. How to incorporate 1200 auto-baud detect into release 3A of TOPS-20.

If you're interested in reading this article it can be found in its' entirety in The Large Buffer, Volume 483, 25-Oct-79, Page 9-11.

THE 72 HOUR BUG
BY: SCOTT HEMPHILL
SOFTWARE SERVICES - MARLBORO

There is a bug in field image versions of TOPS-20 which can cause users to be charged for much more runtime than even the elapsed time of the job. The observed symptom is that the job's runtime is suddenly changed to a large number. The most common value that has been reported to us in the Technical Support Group is a little larger than 72-hours. This figure would be noticed in SYSTATs, WATCH, etc. We have examined all of the monitor code which legitimately touches the JOBRT (JOB RunTime) table, and it appears to be doing the right thing. We therefore believe that the source of the problem is that some other section of code in the monitor is touching the JOBRT table more or less at random, perhaps by indexing off the wrong accumulator.

Unfortunately, there is no easy way to check for such an occurrence. What we have come up with is a DDT patch which uses the address break feature of the KL processor to validate all write references to one (1) entry in the JOBRT table. Use of address break by user of the system would be disabled. A few software specialists have expressed an interest by a customer in installing such a patch to help us track down the source of this problem.

This patch is recommended for use only by noncritical accounts and especially for sites that have seen and/or complained about this problem. The idea is that the customer would run this patched monitor only until one site reports getting a "72 HOUR" BUGHLT. We would then be able to dial-in and take a look at the dump to find out what instruction had illegally referenced the JOBRT table. We would then call every specialist involved to let them know that their customers could stop running the patched monitor, and go back to their standard one.

If anyone knows of a customer who would be willing to install this debugging patch in their monitor, please call the Software Hotline/Marlboro (DTN: 231-6492) and ask for a TOPS-20 monitor person.

NOTE: This article originally appeared in The Large Buffer -
Vol. 486, 15-November-79.

PROCEDURE FOR BOOTING SYSTEM FROM TERMINAL OTHER THAN COLSOLE
(MUST BE LOCAL TERMINAL ON FIRST DH)

BY: AL WEISS
 FIELD SERVICE - NEW YORK

Set PDPII switches as follows:

14-11	Line # of terminal (start with 0) - Example: TTY1 14-11 = 0 TTY2 11-up 14-12 Down																								
7	Up for RP06/4																								
6-3	Speed of terminal No split speed allowed																								
	<table style="border: none;"> <tr> <td></td> <td style="text-align: center;">6</td> <td style="text-align: center;">5</td> <td style="text-align: center;">4</td> <td style="text-align: center;">3</td> <td rowspan="3" style="font-size: 2em; vertical-align: middle;">}</td> <td rowspan="3">FOR OTHER SPEEDS SEE PERIPHERALS HANDBOOK</td> </tr> <tr> <td>300 BAUD</td> <td style="text-align: center;">0</td> <td style="text-align: center;">1</td> <td style="text-align: center;">1</td> <td style="text-align: center;">1</td> </tr> <tr> <td>1200 BAUD</td> <td style="text-align: center;">1</td> <td style="text-align: center;">0</td> <td style="text-align: center;">0</td> <td style="text-align: center;">1</td> </tr> <tr> <td>9600 BAUD</td> <td style="text-align: center;">1</td> <td style="text-align: center;">1</td> <td style="text-align: center;">0</td> <td style="text-align: center;">1</td> <td></td> <td></td> </tr> </table>		6	5	4	3	}	FOR OTHER SPEEDS SEE PERIPHERALS HANDBOOK	300 BAUD	0	1	1	1	1200 BAUD	1	0	0	1	9600 BAUD	1	1	0	1		
	6	5	4	3	}	FOR OTHER SPEEDS SEE PERIPHERALS HANDBOOK																			
300 BAUD	0	1	1	1																					
1200 BAUD	1	0	0	1																					
9600 BAUD	1	1	0	1																					
2-0	Up																								
ALL OTHER SWITCHES DOWN. HIT ENABLE AND SW REG																									

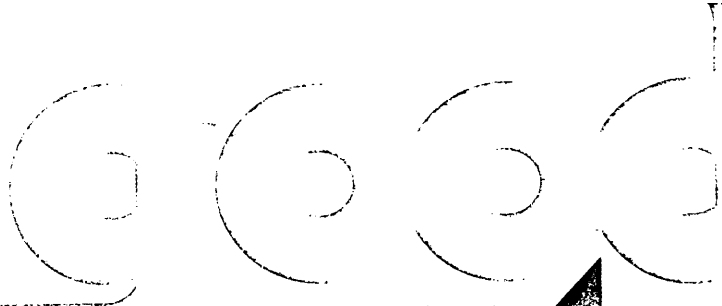

stuff

COMPANY CONFIDENTIAL

This document contains sensitive information which shall not be disclosed to personnel outside of Digital Equipment Corporation.

This Newsletter is meant as an information document. Its contents are not necessarily Company Policy. It's a means by which LCG Product Support can distribute some tidbits of information to you.

IN THIS ISSUE ...

● DIAGNOSTICS

- IMPROVED DIAGNOSTIC CONSOLE PRINTOUT.Page 3
- BR PROBLEMS IN THE 2020Page 4
- DUP-11 DIAGNOSTIC FAILUREPage 6

● HARDWARE

- LP07 TOF PROBLEM.Page 6
- KS10 M8616 REV "E" AVAILABILITYPage 7
- DN6X STATISTICS - TOPS20 RELEASE 4.Page 8
- DC-20Page 9

● MISCELLANEOUS

- FIELD SERVICE ADJUSTABLE SPARES CARDSPage 9
- SNAPSHOTS MADE EASYPage 10

● SOFTWARE

- BOOTS ERROR CODESPage 14
- LP14 HANGS AFTER JOB COMPLETIONPage 15

● SUPPLEMENT: ●●GOOD STUFF INDEX - JANUARY FY'80



SEND ANY ARTICLES WHICH YOU FEEL SHOULD APPEAR IN GOOD STUFF
TO:

GOOD STUFF EDITORIAL OFFICE
c/o NANCIE MITCHELL
MR1-1/S35
DTN: 231-5148
TWX CODE: MR11

ANY FIELD SERVICE EMPLOYEE (700 cost centers only)
REQUESTING GOOD STUFF MUST SUBMIT A MEMO OR TWX TO:

SAME AS ABOVE

WITH THE FOLLOWING INFORMATION:

- NAME
- BADGE #
- COST CENTER
- LOCATION CODE

EDITOR Nigel Webb
ASSOC. EDITOR..Nancie Mitchell
EDITORIAL OFFICE.... MR1-1/S35

GOOD STUFF is published on a
monthly-basis.

IMPROVED DIAGNOSTIC CONSOLE PRINTOUT

BY: ROY SEQUEIRA

LCG PRODUCT SUPPORT - MARLBORO

If your system has no printer you have probably had to struggle through console diagnostic output where one print line has been split into two. This makes it difficult to keep track of the contents of various registers. An example is the simulator output from DBKDA and DBKDB.

If you have an LA36 for a console, here is what you could do to improve this output. Patch SUBRTN and the diagnostic itself.

Using DDQDA-N, DBKDA-C and DBKDB-C, as examples, here are the locations to be changed.

<u>LOCATION</u>	<u>SHOULD BE</u>	<u>COMMENT</u>
6413	CAIG 1, 204	; SUBTRN, CHANGE RH ONLY OF THIS WORD--LEAVE LH AS IS.
32531	JRST 22534	; DBKDAC WE JUMP AROUND THE
33012	JRST 33013	; DBKDAC LINE-SPLITTING CODE.
32317	JRST 32324	; DBKDBC WE JUMP AROUND THE
32602	JRST 32603	; DBKDBC LINE-SPLITTING CODE.

The exact location may differ with different versions. They should, however, stay in the same area of code.

NOTE: CONVRT V14 can be used to get .SAV versions of the above to make patching easier. It is on diagnostic magtape.

BR PROBLEMS IN THE 2020

BY: BOB BARR
REGIONAL PRODUCT SUPPORT - KANATA

Due to the fact that none of our present diagnostics check what BR level is being sent from RH's to the UBA's, the following routines should prove helpful.

DISK ROUTINE

Have a pack up and running.
Then enter KS10 mode:

MR, SM, CH, TEO, TPO	Get machine in known state
EI 1776712	Check for vol. valid
If not	
EI 1776700	
DI 23	Read in preset
EM 101	
DM 500	Set table address
EM 553	
DM 264000 004000	Set JSR at vector entry
EM 4000	
DM 0	
DN 254200 004001	Set up to Halt system
EI 1763100	Check UBA status
DI 000060	Set PIH to Level 6
EI 1776700	Read disk CSR
DI 000107	Recal and interrupt
EM 1000	
DM 701200 000000	Make sure EPT = 0
DN 700600 002202	Set up and turn on PI system
DN 254000 001002	Loop
CS	Start the clock
ST1000	Start subroutine

If the disk interrupt was sent on BR6, the console will print the Halt message with a PC of 4001.

CONT. NEXT PAGE →

MAG TAPE ROUTINE

TE0, TPO, MR, SM, CH	Start in known state
EM 103	
DM 500	Set up pointer entry
EM 545	
DM 246000 004000	Vector entry in table
EM 4001	
DM 254200004-001	Set up to Halt system
EI 3763100	Check UBA status
DI 000060	Set PIH to Level 6
EI 3662440	Mag tape CSR
DI 000107	Rewind and interrupt
EM 1000	
DM 701200 000000	Make sure EPT = 0
DN 700600 002202	Turn on PI Level 6
DN 254000 001002	Loop
CS	Start clock
ST1000	Start subroutine

If an interrupt is sent on BR6 by the mag tape, the Halt message will be printed on the console with a PC of 4001.

It is quite easy by changing the PIH and PIL in the UBA status register to see what level did interrupt and if it is the correct level for the RH11-C.

HARDWARE

DUP-11 DIAGNOSTIC FAILURE

BY: PETER MARIE
M.E.G. - MARLBORO

The following information has been submitted for Tech Tip publication. Thought you might find it useful--please take note:

PROBLEM:

Because the value of R49 (the serial resistor on the EIA external clock lead) is too high, diagnostic DZDPD may fail. It can be seen that signal level being too low is the cause of the failure.

CORRECTION:

ECO M7867-MK006 which upgrades etch Rev. "D" M7867's from CS Rev "J" to "K" will replace R49's present 7.5K ohm resistor with a 5.6K ohm value. Modules showing the problem symptom above should be replaced with upgraded DUP11's and return for rework.

LP07 TOF PROBLEM

BY: BERT LONGO
LSG/M.E.G. - MARLBORO

Several installations have reported TOF problems with LP07 line printers during the past year. The problem manifested itself by coming up one line short from the designated TOF.

The printer manufacturer (DpC) has found the belt to be out of specification. To correct the problem DpC has changed the source of supply.

The Vendor Part Number (VPN) 800617-001 and the DEC Part Number 29-18205 have not changed. The old part is black in color, the new FRU is of amber color.

IF YOU HAVE TOF PROBLEMS, OBTAIN AND INSTALL THE NEW AMBER BELT.

NOTE: If the problem persists, please contact:

BERT LONGO
MR1-1/S35
DTN: 231-6322
or
617-481-9511 X6322

Cross Reference: LP07-TT-8

KS10 M8616 REV "E" AVAILABILITY

BY: PETE MARTI
M.E.G./MARLBORO

A new Revision "E" module is now being shipped. These modules are fully compatible with the exception that Rev "E" is an etch module, and more importantly—the switch locations and settings of the switches have been changed.

The correct switch setting charts for the Revision "E" module are below:

CSL2		CONSOLE TERMINAL					
BAUD RATE	E10 #3	E10 #4	E10 #5	E10 #6	E173 #2	E173 #3	
110	OFF	OFF	OFF	OFF	OFF	OFF	
150	ON	OFF	OFF	OFF	OFF	ON	
• 300	OFF	ON	OFF	OFF	OFF	ON	
600	OFF	OFF	OFF	ON	OFF	ON	
1200	OFF	OFF	ON	OFF	OFF	ON	
1800	ON	OFF	ON	OFF	OFF	ON	
2400	ON	ON	OFF	OFF	OFF	ON	
4800	OFF	ON	ON	OFF	OFF	ON	
9600	ON	ON	ON	OFF	OFF	ON	

• NORMAL FACTORY SETTING
•• SWITCHES #2 & #3 ARE SHOWN ON CSLA

CSL9

REMOTE DIAGNOSIS

BAUD RATE	E10 #1	E10 #2	E10 #7	E10 #8	E173 #4	E173 #7
110	OFF	OFF	OFF	OFF	OFF	OFF
150	ON	OFF	OFF	OFF	OFF	ON
• 300	OFF	ON	OFF	OFF	OFF	ON
600	OFF	OFF	OFF	ON	OFF	ON
1200	OFF	OFF	ON	OFF	OFF	ON
1800	ON	OFF	ON	OFF	OFF	ON
2400	ON	ON	OFF	OFF	OFF	ON
4800	OFF	ON	ON	OFF	OFF	ON
9600	ON	ON	ON	OFF	OFF	ON

• NORMAL FACTORY SETTING
•• SWITCHES #4 & #7 ARE SHOWN ON CSLA

FACTORY SETTING: (9600 Baud-Console) E10 1,2,4,7 ON
(300 Baud-KLINIK) E173 3,7 ON

DN6X STATISTICS - TOPS20 RELEASE 4

BY: PETER MARIE
M.E.G. - MARLBORO

The DN64 software available with TOPS20 Release 3A automatically made entries in the system log file, ERROR.SYS providing notification of the enabling and disabling of lines and periodic statistics reports. In Release 4 of TOPS20 the DN6X software has been integrated into Galaxy, but the code to enter statistics into the system error file was not included. The program IBMCOM provides this service in Release 4 of TOPS20 for both the KS and KL processors.

USING IBMCOM

IBMCOM obtains the status of the front end solely by use of the monitor interface to the DTE. Since IBMCOM does not rely on other DN6X components running in the mainframe it must periodically examine or poll the front end to collect statistics and determine status changes. This polling can affect performance. Only run IBMCOM periodically when you need to collect statistics or when the hardware is suspect.

THE INFORMATION/HELP FILE WILL BE AVAILABLE ON THE DN6X TAPE.
ASK YOUR LOCAL SOFTWARE SPECIALIST FOR THIS INFORMATION.

DC-20

BY: PETER MARIE
LSG/M.E.G. - MARLBORO

An ECO is being released on DC20's that replaces the M7808 module with an M7147. (A performance improved design of M7808).

This will be a phase-in process in Manufacturing. No FCO will be released due to the fact that the modules are functionally identical.

If you need a M7808 module, please order under the new replacement module designation. The new module print set number is: MPO0008.

MISCELLANEOUS

FIELD SERVICE ADJUSTABLE
SPARES CARDS

BY: BOB LATVALLA
CUSTOMER SERVICES SPARES QUALITY

The revised Field Service Adjustable Spares Card became available as of: 1-January-1980. Copies may be obtained by sending a TWX or Memo to:

PRINTING AND CIRCULATION SERVICES
NR2-2/M15

with the following information:

1. Your Name:
2. Location:
3. Badge #:
4. Cost Center:
5. Title: Field Service
Adjustable Spares Card
6. Part #: EK-OSPAR-MC002

SNAPSHOTS MADE EASY
 BY: STEVE BUCHMILLER
 DISTRICT SUPPORT - SO. CALIFORNIA

I have found the following useful when trying to gather information on intermittent KL's. By building a command file that will automatically do a snapshot of the machine, you save time, avoid errors and can even have the customer do it for you (by saving the printout) and resume his production.

There are a few ways to create such a file. Here are some examples:

NOTE: Reference the new KL10 Maintenance Guide

1. BUILD THE COMMAND FILE ONTO A SCRATCH FLOPPY OR DECTAPE VIA KLDCPU. KLDCPU WILL NOT LET YOU WRITE ON THE DISK PACK (RPO-7 ARE READ ONLY). PUT SCRATCH MEDIA ON DRIVE 0 (WRITE ENABLE THE DECTAPE).

```

>.P KLDCPU                ;PULL IN KLDCPU
>.SED                     ;START THE PROGRAM

*DATE: DD-MM-YY          ;INPUT THE DATE
*TEXT DEV:SNAP.CMD      ;COMMAND TO START MAKING THE FILE
                        DEV:=DVO: FOR FLOPPY
                        =DTO: FOR DECTAPE
                        SNAP.CMD=NAME OF THE CMD STRING

";SNAP.CMD              VIII ;THE QUOTE(") IS THE PROMPT
";                       FROM TEXT. TYPE IN THE COMMANDS
";EXAM ELEVEN REGS.     YOU WANT KLDCP TO PERFORM. PRE-
"EE174400,174436        CEED COMMENTS WITH A SEMI-COLON(;)
"DE174432/100          THE SNAPSHOT PROCEDURE IN GOODSTUFF
                        #16 IS RECOMMENDED.

```

CONTINUE INPUTTING YOUR COMMAND STRING UNTIL YOU HAVE TYPED ALL THE COMMANDS YOU WANT KLDCP TO DO FOR YOUR SNAPSHOT.

WHEN YOU ARE FINISHED, PROCEED AS FOLLOWS:

```

";END                    ;THIS IS THE END OF THE STRING
"^Z                      ;CONTROL Z TO EXIT TEXT AND
                        CLOSE THE FILE ON THE MEDIA

*RI                      ;RETURN TO KLDCP
>.DXO OR DTO            ;RE-DIRECT TO FLOPPY OR DECTAPE
>.DI                    ;DO A DIRECTORY TO SEE IF IT
                        MADE IT
>.J SNAP                ;TRY RUNNING IT
                        FOR NAME.CMD=J NAME
                        FOR NAME.CCL=I NAME

```

IF YOU MADE ANY MISTAKES AND NEED TO EDIT THE FILE, YOU CAN USE XTECO (NEW HANDBOOK) TO DO THIS.

```
>.P XTECO                ;PULL XTECO
>.SE 200                 ;START IT
*                         ;XTECO'S PROMPT. USE THE KL
                           HANDBOOK FOR HELP.
```

IF YOU HAVE A BOOTABLE KLDCP FLOPPY OR DECTAPE, THEN YOU CAN COPY THIS FILE TO IT MAKING IT EASIER TO START THE COMMAND FILE. TO COPY FILES UNDER KLDCPU FROM FLOPPY TO FLOPPY OR DECTAPE, DO THE FOLLOWING:

```
>.P KLDCPU                ;PULL IN KLDCPU
>.SED                     ;START THE PROGRAM
*PIP DX0:SNAP.CMD=DX1:SNAP.CMD
```

WHERE DX0: IS FLOPPY 0 WHICH HAS THE BOOTABLE KLDCP FLOPPY AND DX1: IS FLOPPY 1 WHICH HAS THE NEWLY CREATED SNAP.CMD.

NOW YOU CAN BOOT THE FLOPPY, RE-DIRECT KLDCP TO DX0 AND START THE COMMAND FILE ALL WITH ONE FLOPPY.

```
EXAMPLE:
PRESS ENABLE AND FLOPPY
WHEN KLDCP PROMPTS, YOU TYPE:
>.DX0
>.J SNAP
&gt.SNAP.CMD                VIII
```

AND NOW THE FILE WILL DO THE SNAPSHOT FOR YOU

2. ANOTHER METHOD OF CREATING THE COMMAND FILE IS TO BUILD IT USING TOPS-20 AND EDIT UNDER TIMESHARING. IF YOUR KLAD HAS A PROGRAM CALLED FE.EXE. FE.EXE IS A PROGRAM THAT TRANSFERS FILES FROM THE -10 SIDE TO THE -11 SIDE. WITHOUT THIS PROGRAM YOU CAN'T GET IT TO THE -11 SIDE TO USE IT.

```
$CREAT SNAP.CMD
INPUT SNAP.CMD
100 ;SNAP.CMD            VIII
200 ;
300 ;EXAMINE ELEVEN REGISTERS.
400EE174400,174436
500DE174432/100
```

CONTINUE AS BEFORE USING A SEMI-COLON(;) WHEN MAKING COMMENTS.
ALL COMMANDS WILL BE EXECUTED BY KLDPCP, SO TYPE THEM ACCORDINGLY.

WHEN DONE, TYPE:

```
XX00 $(ESCAPE)
*EU                               ;TO SAVE THE FILE AND
                                   ;REMOVE LEADING LINE #'S
[SNAP.CMD]
```

NOW WE HAVE TO COPY IT TO THE FRONT END SO WE CAN USE IT

```
$COPY SNAP.CMD <OPERATOR>SNAP.CMD
```

AFTER COPYING THE FILE TO THE <OPERATOR> AREA, RUN THE PROGRAM TRANSLATE TO FIND OUT THE PROGRAMMER PROJECT NUMBER (PPN). THE PPN WILL BE NEEDED LATER ON.

```
$RUN FE
THE CONSOLE WILL NOT PRINT ANYTHING WHILE RUNNING FE.EXE
```

NOW GO TO THE CONSOLE CTY AND PROCEED AS FOLLOWS:

```
^\  
PAR>M MOU                          ;CONTROL BACKSLASH TO ENVOKE  
MOU>FE:                             ;START THE MOUNT TASK  
MOU-MOUNT COMPLETE                 ;MOUNT FE AS A DEVICE  
MOU>^Z                              ;CONTROL-Z TO EXIT MOU  
^\  
PAR>M PIP                          ;ENVOKE PARSER AGAIN  
                                   ;START THE PIP TASK
```

```
PIP>DBO:[6,11]SNAP.CMD=FE:[340,X]SNAP.CMD
```

WHERE "X" IN THE [340,X] IS THE RIGHT HALF NUMBER YOU RECEIVED IN THE "TRANSLATE" OPERATION.

IF YOU HAD COPIED THE FILE TO <OPERATOR>, YOU COULD ALSO HAVE USED THE FOLLOWING:

```
PIP>DBO:[6,11]SNAP.CMD=FE:[1,2]SNAP.CMD
```

THIS WILL COPY THE FILE FROM THE OPERATOR AREA TO THE [6,11] AREA OF THE FRONT END.

```
PIP>^Z                              ;EXIT PIP  
^\  
PAR>M DMOU                          ;ENVOKE PARSER  
DMO>FE:                             ;RUN THE DISMOUNT TASK  
DMO-DISMOUNT COMPLETE  
DMO>^Z                              ;EXIT DMOU
```

```
NOW KILL FE.EXE WITH TWO CONTROL C'S
$^EASE +1                               ;BRING DOWN THE SYSTEM
                                           ;TO TRY THE NEW COMMAND FILE
```

```
WHEN SHUTDOWN, COMPLETE:
^\                                       ;ENVOKE PARSER
PAR>SHUT                               ;SHUTDOWN
***HALTED***
```

```
%DECSYSTEM-20 NOT RUNNING
^\                                       ;ENVOKE PARSER
PAR>M BOO                               ;START THE BOOT TASK
BOO>DBOOT                               ;RUN DBOOT FOR KLDCP
KLDCP WILL NOT COME IN
>.J SNAP                               ;TRY RUNNING THE COMMAND FILE
```

```
NOW YOU CAN COPY THIS TO A FLOPPY USING KLDCPU
>.P KLDCPU
>.SED
```

```
*PIP DXO:SNAP.CMD=RPO:SNAP.CMD
THIS WILL COPY THE FILE TO FLOPPY 0
*RI                                     ;TO RETURN TO KLDCP
```

NOTE: YOU CANNOT COPY FROM FLOPPY TO DISK USING KLDCPU. THE DISKS ARE
CONSIDERED READ ONLY.

With a little practice you can become quite clever and create
some very useful files that can save you time and trouble. Just
be careful when writing to your disks.

Any questions or correspondence is welcome. (714)979-2460 X239

BOOTS ERROR CODES
SUBMITTED BY: CARY DE VAN
PRODUCT SUPPORT - UTRECHT

This information is good for 6.03, 6.03A, along with 7.00 TOPS-10.

BOOTS error codes can occur when you are loading the system or when you are taking a dump of memory. The codes with an adjoining asterisk usually indicate damaged file structures; in such a case the disk should be refreshed.

<u>ERROR CODE</u>	<u>EXPLANATION</u>
?B	No comma inside a pair of brackets
?C	Illegal switch or no start address before a /G
?D	Input error
?E	Input error when trying to read the EXE directory
?F	First page of the file is not an EXE directory or it is an EXE directory that is too long
?G	EXE directory describes pages that do not increase monotonically
?H	Premature end-of-file
?I	Output error
?J	Cannot find the file specified
* ?K	Bad RIB
* ?L	Premature end-of-file when reading the UFD
* ?M	Tried to read or write block 0
* ?N	Logical block number exceeds disk size
?O	End-of-file when trying to output

LP14 HANGS AFTER JOB COMPLETION

BY: BERT LONGO
M.E.G. - MARLBORO

If the LP14 drum gate is open with DAVFU loaded, it is necessary to activate the "Master Clear" switch in order to resume printing.

The switch activation causes an interrupt, printing is resumed, job is completed (buffer is cleared) and thereafter printer hangs with the following error message:

"LPTULE" and/or "HANGING"

To correct this situation a patch, edit level 2310, was created to replace edit level 2263.

Please insure that the patch is installed in Release 103 of LPTSPL.

The SPR on the following pages is presented for your convenience.

CONT. NEXT 2 PAGES →

Digital Equipment Corporation 25-OCT-79 Page 1
Answer to SPR #:20-10902

Pre-printed number: 126016
Field Number:

Installation: TERADYNE, INC.

ASSOCIATED PCO #'S: LPTSPL-018

[Validity] 102(2263)
[Date cured] 18-JAN-78 in SPR # 20-10902
[Routines] OUTERR
[Key Words] LPTULE HANGING
[Source Before Edit] %102A(2277)
[Source After Edit] %103A(2310)

[SYMPTOM]

LPTSPL hangs after typing the message

%LPTULE Unexpected Line printer Error on PLPT0, status n

Terminal input is ignored and a control-T reveals that LPTSPL is
in IO wait.

[DIAGNOSIS]

When handling this error, LPTSPL turns off the interrupts, but
then never turns them on afterwards.

[CURE]

Digital Equipment Corporation
 Answer to SPR #:20-10902

25-OCT-79

Page 2

Turn on the interrupts after getting the status and printing the error message.

This patch will not be in Release 103 of LPTSPL, but it may be installed in Release 103 without changes.

[FILCOM]

File 1) DSKB:LPTSPL.MAC[30,4661,GALAXY] created: 1231 13-May-77
 File 2) DSKC:LPTSPL.MAC[30,4661,GALAXY,DEBUG] created: 1145 18-Jan-78

```

1)1    SUBTTL  D.A. Lewine - L.S. Samberg/LSS 29-Mar-77
1)      ;Copyright (C) 1970,71,72,73,74,75,76,77,
****

2)1    SUBTTL  D.A. Lewine - L.S. Samberg/LSS/LLN 18-Jan-78
2)      ;Copyright (C) 1970,71,72,73,74,75,76,77,
*****

1)1          LPTMIN==0                ;MINOR VERSION NUMBER
1)          LPTEDT==2263              ;EDIT          1)
1)          LPTWHO==0                 ;WHO LAST PATCHED
****

2)1          LPTMIN==1                ;MINOR VERSION NUMBER
2)          LPTEDT==2310              ;EDIT LEVEL
2)          LPTWHO==0                 ;WHO LAST PATCHED
*****

1)5    SUBTTL  AC and I/O Channel Definitions
****

2)4      ;2310 Turn on the interrupts after processing LPTULE
2)      ; errors. LLN, SPR # 20-20902, 18-Jan-78
2)5    SUBTTL  AC and I/O Channel Definitions
*****

1)147      JRST      OUTE.3                ;AND CONTINUE
****

2)147      ;**:[2310] ADD ONE LINE AT OUTE.1: + 1L, UNDER
2)      ;**:[2310] IFN FTJSYS CONDITIONAL. LLN, 18-JAN-78
2)          PUSHJ    P,INTON                ;[2310] TURN ON INTERRUPTS
2)          JRST     OUTE.3;                ;AND CONTINUE
*****

```

[End of answer to SPR #:20-10902]

stuff

COMPANY CONFIDENTIAL

This document contains sensitive information which shall not be disclosed to personnel outside of Digital Equipment Corporation.

This Newsletter is meant as an information document. Its contents are not necessarily Company Policy. It's a means by which LCG Product Support can distribute some tidbits of information to you.

IN THIS ISSUE ...

●HARDWARE

- BOOTSTRAP DOESN'T START AFTER A POWER UP Page 3
- CAUTION ON COLLECTING DATA WITH SBUS ERRORS. Page 4
- LP07-R-0024. Page 4
- MODEM STRAPPING FOR DECNET LINES Page 5

●MISCELLANEOUS

- REWORK AND REPAIR OF MODULES AND BACKPLANES. Page 9
- REMOTE DIAGNOSIS NEWS. Page 10
- HAS YOUR ADDRESS CHANGED?. Page 11
- COMMONLY ASKED QUESTIONS ABOUT THE S/X BUS RECORDER. Page 12
- GOOD STUFF ON SPEED BULLETIN Page 14
- FOR YOUR INFORMATION Page 14

●SOFTWARE

- RP04 AND RP06 PROBLEMS WITH 6.03A. Page 15
- SETTING SOFTWARE SWITCHES PERMANENTLY IN RSX20F. Page 19

●SUPPLEMENT:

- TOPS-10 DN87 DUMP ANALYSIS PROGRAM

FOR YOUR INFORMATION

ANY FIELD SERVICE EMPLOYEE (700 COST CENTERS ONLY) WISHING TO BE ADDED/DELETED TO THE GOOD STUFF DISTRIBUTION LIST MUST SUBMIT A MEMO OR TWX TO:

NANCIE MITCHELL
MR1-1/S35
DTN: 231-5148
TWX CODE: MR11

WITH THE FOLLOWING INFORMATION:

- YOUR NAME
- BADGE #
- COST CENTER
- LOCATION CODE
- ADDED DELETED

ALSO, SEND ANY ARTICLES WHICH YOU FEEL SHOULD APPEAR IN GOOD STUFF TO:

GOOD STUFF EDITORIAL OFFICE
c/o NANCIE MITCHELL
MR1-1/S35
DTN: 231-5148
TWX CODE: MR11

EDITOR NIGEL WEBB
ASSOC. EDITOR. .NANCIE MITCHELL
EDITORIAL OFFICE . . .MR1-1/S35

GOOD STUFF is published on a monthly basis.

CAUTION ON COLLECTING DATA WITH
SBUS ERRORS

BY: DINO GENOVA/LARRY MIDURA
LSG PRODUCT SUPPORT/M.E.G.

The data latched in the ERA after an SBUS error may be misleading. This is due to the fact that several asynchronous events may be occurring. i.e.: The channel may be reading/writing to memory and the EBOX is utilizing cache. If the DMA detects a NXM on a word other than the first word of a quad word read/write while the EBOX is making a cache reference, the ERA will reflect the EBOX reference and not the channel reference.

This may also happen during a cache write back cycle where the address being written is relative to the address stored in the cache directory and not the address being referenced by the EBOX.

The latching of the ERA from SBUS error has been removed on Model B machines for the preceding reasons. Model A's latch the ERA on SBUS error, but the information could be misleading.

LP07-R-0024

BY: JOE SWEENEY
M.E.G. - MARLBORO

A check on the status of FCO LP07-R-0024 has indicated that only a handful of EQ kits for this FCO have been ordered and installed.

This FCO prevents multiple loading of DAVFU data on slow interface systems, and corrects timing to prevent image altering during paper runaway fault.

In the event that a field test is required for any future LP07 FCO, it will be imperative that LP07-R-0024 be installed. It increases the reliability of the printer and would have to be installed in order to obtain accurate results of any future field test.

Please order EQ-00927-001 and have it installed.

MODEM STRAPPING FOR DECNET LINES

BY: PETER MIERSWA
NCSS

When configuring a communications network one must choose common carrier switched or leased, or private lines, modems or null modems, and communications interfaces. The configuration must be hardware and software compatible, fast enough, reliable enough, and within your budget. DECnet-20 V1.0 (TOPS20 release 3A) and DECnet-20 V2.0 (TOPS20 Release 4) support only synchronous full duplex (4-wire) point to point communication links with no dial up or dial out capabilities.

Listed below are a number of techniques for connecting two nodes to support DECnet-20. Remember that only the modems and communications interfaces listed in the current SPD are supported. All configurations require network profiles and customer support plans, and any configuration using non-standard facilities should include PL90 estimates for support.

1. Directly connected DMC11's. Two DMC11-AL's with line units can be connected directly with coaxial or triaxial cables over short distances.
2. Two communication interfaces can be connected by a synchronous null modem or modem eliminator over short distances.
3. Two synchronous modems, each connected to one communication interface can be directly connected by a 4-wire private line. This can be as little as 4-wires each a few feet long.
4. Two synchronous modems, each connected to one communication interface can be connected by a 4-wire line leased from a common carrier such as the Bell system.
5. Two synchronous modems with dial backup capability, each connected to one communications interface can be connected by two DDS calls in the Bell system. This is not supported.

CONT. NEXT 3 PAGES →

Following are the options needed for the modems used in DECnet-20 connections.

NULL MODEM or MODEM ELIMINATOR (any speed)

This device connects two communications interfaces over a short distance. The only option normally offered is choice of line speed. If the speed is not switch selectable, choose a speed within the limits of the communications interfaces. Remember that a null modem for synchronous communications must provide a clocking signal. The Digital H312-A cannot be used; it has no internal clock.

COAXIAL or TRIAXIAL CABLE (56 KB or 1000KB depending upon the device)

When connecting two DMC11-AL/DMC11-MA or DMC11-AL/DMC11-MD communications interfaces, only cables and connecting wires are required. They can be connected only over short distances. These devices contain their own clock sources. No other communications interfaces can be connected without modems or modem eliminators.

BELL SYSTEM 201C (2400 bits per second)

Bell 201C and 208A modems are similar. The following options are specific to the 201C. See also the modem strapping options for the 208A.

No automatic calling unit. The Bell 801/Digital DN11 configuration for making outgoing calls is not supported.

Permanent auto answer. This doesn't matter for leased line connections, but is important in dial backup situations to prevent the need for operator intervention at the called site.

Four wire line interface. Full duplex communication requires a 4-wire interface.

Zero millisecond RTS/CTS delay. Full duplex communication with constant carrier does not do line turn-around or in any other way wait for the carrier to settle.

BELL 208A (4800 bits per second)

The following modem strapping options are common to the Bell 208A and the Bell 201C.

AA connected to AB. This option connects protective ground (AA) to signal ground (AB).

Clock source internal. Clocking for data transfer is provided by the modem.

Continuous carrier. Full duplex operation requires continuous carrier.

New synch without. This option is only used in multidrop configurations.

Alternate voice either way. This is the customers choice, it makes no difference to the communications interface.

Switched network backup either way. Switched network backup allows the customer to place two phone calls through the dds network to provide a communications path if his lease line is failing. If uninterrupted service is important, choose this option. With the cooperation of your local Bell salesman, this option can also be used to provide 4-wire service without purchasing a leased line. This would provide a low volume DECnet link with much cheaper common carrier rates than would be possible with a leased line.

The following options are specific to the Bell 208A only.

CC indication of analog loopback on. In analog loop test mode this option enables the data set ready lead (DSR) which the DN20 requires before transmission can begin.

Continuous request to send in continuous carrier mode.
Switched request to send is only used in certain mulidrop configurations.

One second holdover at receiver on line dropout provided. This prevents loss of the connection when carrier drops for very short times. Since DDCMP performs its own error checking, any errors encountered during short carrier losses will be corrected through re-transmission.

ICC COMLINK II (up to 19200 bits per second)

No information currently available.

BELL 303 CURRENT LOOP (up to about 200,000 bits per second?)

No information currently available. Please note that this is a wide band or high speed modem. However, in the SPD for DECnet-20 V1.0 the only communications interface offered which operates at speeds higher than 19.2KB is the DMC11-AL/DMC11-MD which is not used with a modem, but with coaxial cable.

NOTE:

As a special bonus, here is a copy of the pin definitions for the 25 pin connectors you will find on your modems. These will be helpful when you are using a breakout box to try to diagnose a communications problem.

PIN	NAME	TO	TO	FUNCTION	CIRCUIT	
		DTE	DCE		(CCITT)	(EIA)
1	FD			FRAME GROUND	101	(AA)
2	TD		>	TRANSMITTED DATA	103	(BA)
3	RD	<		RECEIVED DATA	104	(BB)
4	RTS		>	REQUEST TO SEND	105	(CA)
5	CTS	<		CLEAR TO SEND	106	(CB)
6	DSR	<		DATA SET READY	107	(CC)
7	SG			SIGNAL GROUND	102	(AB)
8	DCD	<		DATA CARRIER DETECT	109	(CF)
9		<		POSITIVE DC TEST VOLTAGE		
10		<		NEGATIVE DC TEST VOLTAGE		
11				UNASSIGNED		
12	SDCD	<		SEC. DATA CARRIER DETECT	122	(SCF)
13	SCTS	<		SEC. CLEAR TO SEND	121	(SCB)
14	STD		>	SEC. TRANSMITTED DATA	118	(SBA)
15	TC	<		TRANSMITTED CLOCK	114	(DB)
16	SRD	<		SEC. RECEIVED DATA	119	(SBB)
17	RC	<		RECEIVER CLOCK	115	(DD)
18			>	RECEIVER DIBIT CLOCK		
19	SRTS		>	SEC. REQUEST TO SEND	120	(SCA)
20	DTR		>	DATA TERMINAL READY	108.2	(CD)
21	SQ	<		SIGNAL QUALITY DETECT	110	(CG)
22	RI	<		RING INDICATOR	125	(CE)
23			>	DATA RATE SELECT	111/112	(CH/CI)
24	(TC)		>	EXTERNAL TRANSMITTER CLOCK	113	(DA)
25			>	BUSY		

REWORK AND REPAIR OF MODULES AND BACKPLANES

BY: KEN ADAMETZ

A.S.M. - QUALITY ASSURANCE

The color code chart below should be used for repair and/or rework of standard 30 awg ASM produced backpanels and wire wrapped modules after the original wrap. The use of these color codes do not apply to any KL10's due to special wire requirements of the logic used in the system or any other product with special wire requirements.

GREEN. INSTALLATION OF ECO SINGLE
WIRE RUNS

RED/WHITE TWISTED PAIR TWISTED PAIR ECO

BLUE REPAIR OF SINGLE WIRE RUNS

BLUE/WHITE TWISTED PAIR. REPAIR OF TWISTED PAIR RUNS

The above color code should be followed unless otherwise specified by ECO or by specific rework instructions.

- Yellow wire should only be used for original wrap of a module or backplane.
- White wire should only be used for etch repairs.
- Black/white twisted pair wire should only be used for original twisted pair wraps.

In addition to the above mentioned specifications, the standards set forth in DEC STD116, the workmanship standards, shall also apply.

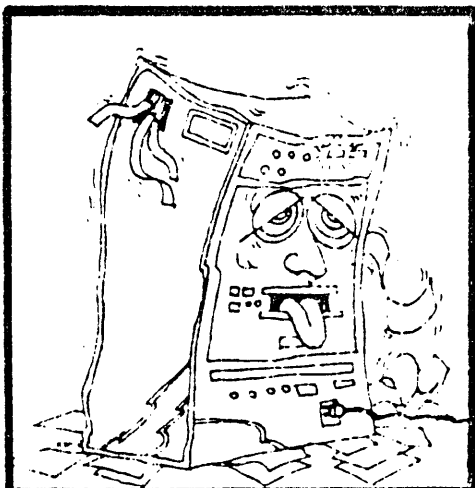

REMOTE DIAGNOSIS NEWS

BY: LYNN HOLDEN

RD DEVELOPMENT - MAYNARD

Remote Diagnosis News is published monthly. Its' purpose is to provide Remote Diagnosis related information to personnel within Digital. RD News focuses primarily on non-technical new concepts, developments and achievements within the Remote Diagnosis Development organization.

It is hoped that the articles contained in the newsletter provide new information, stimulate thinking, raise questions and perhaps suggest some answers.

Here are some examples of what you'd find:

- The RD Scripting Process
- RD Centers open in Europe
- VAX 11/780 RD UUT Environment
- KC780-BA Installation Kit Modification Bulletin
- KY11-R Installation Kit Modification Bulletin
- Hints to cut phone costs
- RD Questions and Answers
- DDC Corner

For more information or to be placed on the Distribution for this publication...send name, badge #, cost center, and location code, to:

EDITOR: LYNN HOLDEN
RD DEVELOPMENT
PK3-2/H29
MAYNARD, MA 01754

HAS YOUR ADDRESS CHANGED?

BY: NANCIE MITCHELL

GOOD STUFF EDITORIAL OFFICE - MARLBORO

HAVE YOU BEEN RECEIVING GOOD STUFF ALL ALONG AND ALL OF A SUDDEN YOU MOVE TO A NEW LOCATION AND NO MORE GOOD STUFF?

SOLUTION: FOR U.S. PERSONNEL

It is very important to update your Personnel Profile showing all necessary changes, i.e.: location code, mailing address, cost center (if applicable), etc. (Your Cost Center Manager should have a copy of your profile).

Once these changes are complete and submitted to personnel they will automatically be changed on my distribution list.

SOLUTION: FOR EUROPEAN PERSONNEL

If you are located in Europe, GIA, or Canada you must send a TWX or memo to:

NANCIE MITCHELL
MR1-1/S35
TWX CODE: MR11
CC: 70M

with the following information:

YOUR NAME
BADGE #
NEW COST CENTER
NEW LOCATION CODE

NOTE: This information only applies to individuals already on my distribution list.

Any individuals wishing to be added or deleted to the Good Stuff mailing list should refer to Page 2 of Good Stuff.

COMMONLY ASKED QUESTIONS ABOUT THE S/X BUS RECORDER

BY: LARRY MIDURA

M.E.G. - MARLBORO

Question #1: What is it?

Answer: The S/X Bus Recorder is part of the KLSEP (KL Service Enhancement Project) and was designed by L.C.G. Engineering in order to detect and trap problems on the SBUS (DMA20 and internal memory type) and XBUS (MOS-MF20 type memory). Reference: Goodstuff #24 - Page 6.

Question #2: Who is supposed to use it?

Answer: The target users of the recorder are District Support Groups with a recorder-to-processor ratio of one recorder/10 KL's, (with an extra recorder in the Regional Support area's and large MACRO-10 cost centers).

Question #3: How many recorders can I use at one time?

Answer: You can have two (2) recorders connected (one on each SBUS or XBUS in any combination of SBUS or XBUS). Most probably your next question is:

Question #4: How do I get one?

Answer: Through Capital Equipment with Part #'s as follows:

9307042-A 50 HZ
9307042-B 50 HZ

Question #5: If I ordered one now when would it be available?

Answer: It should be available by Q1 of 1981. (July, August, September - 1980)

CONT. NEXT PAGE →

Question #6: Is it possible to get a demonstration of the recorders power and capabilities?

Answer: If you can come to Marlboro and contact:

Larry Midura
MR1-1/S35
DTN: 231-4257
617-481-9511 X4257

A demonstration could be arranged in order for you to evaluate the recorder.

Question #7: If I can't get to Marlboro will there be any presentation in the Field?

Answer: Currently the recorder is required by Diagnostic Engineering and cannot be removed until the diagnostic is complete. Once it is done, the recorder will be available for demonstration in the Regions with those people who will be using/ordering one.

Question #8: I have an intermittent machine that is getting DEX errors and assorted memory problems. Is there a chance I could borrow a recorder until the one I order is available?

Answer: Once Diagnostic Engineering is done, the recorder will be available on a first-come--first-served basis.

Question #9: I still have some questions?

Answer: Contact:

Larry Midura
MR1-1/S35
DTN: 231-4257
617-481-9511 X4257

GOOD STUFF ON SPEED BULLETIN
BY: NANCIE MITCHELL

<u>ISSUE #</u>	<u>SPEED BULLETIN</u>	<u>ISSUE #</u>	<u>SPEED BULLETIN</u>
1	#110 - DEC 17, 1979	13	#112 - JAN 7, 1980
2	#110 - DEC 17, 1979	14	# 67 - JAN 11, 1979
3	#110 - DEC 17, 1979	15	# 72 - FEB 26, 1979
4	#110 - DEC 17, 1979	16	# 75 - MAR 19, 1979
5	#110 - DEC 17, 1979	17	# 77 - MAR 9, 1979
6	#110 - DEC 17, 1979	18	# 82 - MAY 14, 1979
7	#110 - DEC 17, 1979	19	# 84 - MAY 29, 1979
8	#110 - DEC 17, 1979	20	# 94 - AUG 12, 1979
9	#110 - DEC 17, 1979	21	#112 - JAN 7, 1980
10	#110 - DEC 17, 1979	22	#112 - JAN 7, 1980
11	#112 - JAN 7, 1980	23	#112 - JAN 7, 1980
12	#112 - JAN 7, 1980	24	#112 - JAN 7, 1980

NOTE: This information will be included in the next update of the Good Stuff Index.

FOR YOUR INFORMATION

● 2020 CARDREADER PATCH FOR
RELEASE 3A

published in the Large Buffer - Volume 490, 13-December-79, pgs. 29-30.

CONTENTS: A patch which corrects the known problems with the monitor (for the lower-speed reader).

● WRONG FREE BLOCK COUNT
FROM OMOUNT

published in the Large Buffer - Volume 433, 29-November-79, pgs. 11-12.

CONTENTS: A description of the problem and how it was corrected. Also, includes a code whereby if your customers are experiencing this problem, you can edit their sources to agree with this code.

RPO4 AND RPO6 PROBLEMS WITH 6.03A

BY: KENNETH P. YOUNG
MR1-2/S43

With 6.03A, some disk problems which were soft errors in 6.03 are now hard errors as the result of several bugs. If any site is experiencing a higher hard error rate with 6.03A than with 6.03, the PCOs listed on the following pages should be installed.

PCO #:10-603A -085

[SYMPTOM]

Format error reported to program on header compare error.

[DIAGNOSIS]

IODERR set in S when it should not be.

[CURE]

Test for Header Compare Error (HCE), if set clear IODERR.

[FIL.COM]

```
.EDIT 8631
.DATE 27-JUN-79
.MODULE RPXKON
.INSERT ERROR1,REPLACE:3,<TLINE T3,HCE+HCRC>
      TLNN      T3,HCE+HCRC      ;[8631]
      JRST      ERROR2          ;[8631]
      TRO       S,IOHDER+IODTER ;[8631]
      TRZ       S,IODERR        ;[8631] IF HEADER ERROR TURN OFF IODERR
ERROR2: SKIPG   RPXFLG##(J)     ;[8631]
.ENDI
.ENDE
```

[End PCO Write-up]

```
*****
*PCO #:10-603A -110*
*****
```

```
*****
```

[SYMPTOM]

No offset error recovery for HCE or HCRC errors on RP04 or RP06 disk drives.

```
*****
```

[DIAGNOSTICS]

The wrong AC is being tested to see if IOHDER (1000) is set.

```
*****
```

[CURE]

Test P2 instead of T2 for IOHDER.

[FILCOM]

```
.Edit 8633
.Module FILIO
.Date 16-Jul-79
```

```
;SPR 10-28321
```

```
IFN FTRP04,<
```

```
.Insert POSERB+4, replace, <TRNN T2,IOHDER>
```

```
TRNN P2,IOHDER ;Header error?
```

```
.ENDI
```

```
>;End IFN FTRP04
```

```
.ENDE
```

[End PCO Write-up]

```
*****
*PCO #:10-603A -166*
*****
```

```
*****
```

[SYMPTOM]

Incorrect data is read from the disk (RPO4, RPO6).

```
*****
```

[DIAGNOSIS]

The ECC polynomial can miscorrect a double-bit error.

```
*****
```

[CURE]

Try reread before applying ECC.

[FILCOM]

```
.EDIT 8644 ;INCLUDES EDIT 8921
.DATE 03-DEC-79
.MODULE RPXKON

.INSERT DATIN1+10,AFTER,<XCT RPXC12##(J)>
      MOVE U,KONCUA##(J) ;[8644]
.ENDI

.INSERT DATIN2+5,REPLACE:1,<MOVE U,KONCUA##(J)>
.ENDI

.INSERT ERRDON-2,BEFORE,<TLNN T3,ECH>
      SKIPGE UNIECT##(U) ;[8644] IF INITIAL ERROR
      JRST ERRDON ;[8644] REREAD BEFORE TRYING
.ENDI

.ENDE
```

[End PCO Write-up]

 PCO #:10-603A -167

[SYMPTOM]

Cannot read from RPO4,RPO6 without error.

[DIAGNOSIS]

If disk gets an HCE error without HCRC, it may be mispositioned.
 If so, a recalibrate must be done before the disk can be read
 without error.

[CURE]

If HCE=1 HCRC=0, do a recall if retry at offset fails.

[FILCOM]

```
.EDIT 8645 ;INCLUDES 8762
.DATE 03-DEC-79
.MODULE RPXKON

.INSERT RPXR2+10,REPLACE:3,<TRNN T2,-1>
  TRNE T2,-1 ;[8645] IS THIS OFFSET=0?
  JRST RPXR2A ;[8645] NO--GO DO IT
  MOVE T2,KONEBK##+2(J) ;[8645] YES--RETURN TO CENTER LINE
  TRNE T2,HCE ;[8645] UNLESS HCE=1, HCRC=0
  TRNE T2,HCRC ;[8645]
  SKIPA T1,[FNCRTC] ;[8645]
  MOVEI T1,FNCRCL ;[8645] IN WHICH CASE DO A RECALL
RPXR2A: HRROS RPXFLG##(J) ;[8645] SET RPXFLG NEGATIVE
.ENDI

. ENDE
```

[End PCO Write-up]

RSX-20F

SETTING SOFTWARE SWITCHES PERMANENTLY IN RSX20FBY: TOM KILPATRICK
SEATTLE FIELD SERVICE

Would you like to be able to set reload off permanently? The following procedure will explain how to set reload, klinik and console mode to desired states and save RSX20 with these settings, then when you reboot, these switches will be set.

With TOPS10 or TOPS20 down, do a 203 switch register boot. Then do ^\. This should give you a PAR% prompt. Now, set reload, klinik or console mode to desired states.

i.e.:

```
PAR% SET NO RELOAD
PAR% SET KLINIK
MODE?      USER
ACCESS    Window open date: (CR)
ACCESS    Window open time: (CR)
ACCESS    Window close date: 31-DEC-80
ACCESS    Window close time: (CR)
```

PAR% SET CONSOLE PROGRAMMER

Now that the switches are set up, save core image as RSX20 boot.

PAR% M SAVSav) SY:/WB

RSX-20F VE12-40 7:43 29-NOV-78

(SYO: REDIRECTED TO DBO:)

(DBO: MOUNTED

PAR%

GOOD

ISSUE NO. 28

APRIL FY '80

stuff

COMPANY CONFIDENTIAL

This document contains sensitive information which shall not be disclosed to personnel outside of Digital Equipment Corporation.

This Newsletter is meant as an information document. Its contents are not necessarily Company Policy. It's a means by which LCG Product Support can distribute some tidbits of information to you.

IN THIS ISSUE ...

● HARDWARE

- MODEL 2420/2440/2470 UNWANTED OFF-LINE CONDITIONPage 3
- EBOX/MBOX ACCOUNTING AND THE CLOCK ON THE WALLPage 4
- TROUBLESHOOTING MASSBUS PARITY ERRORS (CBPE OR DBPE)
WITH AN RH10Page 8
- SEARCH ERRORS ON RPO2S OR RPO3S.Page 10
- DN87S - FCO #1Page 12

● KLAD

- KLAD10 REV 12/4 TOPS10 MONITORPage 13

● MISCELLANEOUS

- CORRECTION - SITE PREPARATION GUIDE.Page 14
- OPTION JUMPERSPage 14
- SUBMITTING A TECH TIP.Page 15
- LOADING .A11 or .BIN IN SECONDARY FRONT ENDSPage 15

● SOFTWARE

- DATA MISSED ERRORS WITH CR10E ON A 1090 SYSTEMPage 16

● SUPPLEMENTS

- D.I.E. - Diagnostic Information Enquiries
- SPD - DECNET-10, VERSION 2.0 TOPS-10 NETWORK SOFTWARE
- TOPS-20 RELEASE 4 UPDATE

FOR YOUR INFORMATION

ANY FIELD SERVICE EMPLOYEE (700 COST CENTERS ONLY) WISHING TO BE ADDED/DELETED TO THE GOOD STUFF DISTRIBUTION LIST MUST SUBMIT A MEMO OR TWX TO:

NANCIE MITCHELL
MR1-1/S35
DTN: 231-5148
TWX CODE: MR11

WITH THE FOLLOWING INFORMATION:

- YOUR NAME
- BADGE #
- COST CENTER
- LOCATION CODE
- ADDED DELETED

ALSO, SEND ANY ARTICLES WHICH YOU FEEL SHOULD APPEAR IN GOOD STUFF TO:

GOOD STUFF EDITORIAL OFFICE
c/o NANCIE MITCHELL
MR1-1/S35
DTN: 231-5148
TWX CODE: MR11

EDITOR NIGEL WEBB
ASSOC. EDITOR. .NANCIE MITCHELL
EDITORIAL OFFICE . . .MR1-1/S35

GOOD STUFF is published on a monthly basis.

MODEL 2420/2440/2470 UNWANTED OFF-LINE CONDITION

BY: JOE KELLEHER
 PRODUCT SUPPORT - MARLBORO

Data Products made a design change to prevent 2400 series line printers from going off-line due to internal noise.

The unwanted off-line condition occurred very infrequently and was found to be caused by noise on the voltage monitor (VMON*) line intermittently setting the master clear circuit on the AZ-115/AG-50 master clear board.

It was determined that the voltage monitor signal was redundant at the master clear board. Therefore, the VMON* signal was removed from A3A13 Pin 16 by a wiring change to the logic card cage.

If your printer is experiencing this unwanted off-line condition, the following wiring change should eliminate this problem.

NOTE: All 2400 series line printers shipped from Data Products after 8-August-75 have this wiring change incorporated.

For Line Printers shipped from Data Products prior to 8-August-75, the following wiring change may be performed to alleviate the problem.

	SUB ASSY	SLOT	PIN		SUB ASSY	SLOT	PIN	SIGNAL NAME
DELETE	A3	A13	16	TO	A3	A12	53	VMON*
DELETE	A3	A13	16	TO	A3	A8	18	VMON*
DELETE	A3	A21	50	TO	A3	A18	40	DRRS
ADD	A3	A12	53	TO	A3	A8	18	VMON*
ADD	A3	A13	16	TO	A3	A21	50	DRRS
ADD	A3	A21	50	TO	A3	A18	40	DRRS

If you have difficulty making this change, remember the object is to remove A3A13 Pin 16, from the VMON* wire run and place it on the DRRS wire run.

Also, should you perform this change remember to update the printers print set accordingly.

NOTE: This article has been submitted to Maynard for CPL Tech Tip publication.

EBOX/MBOX ACCOUNTING AND THE CLOCK ON THE WALL

BY: DAVE NEWMAN
LEEDS

SUMMARY

A customer finds that 20% of his KL time goes missing -- lost or not charged. This article outlines the explanation given, and questions the idea of accounting by time.

INTRODUCTION

We recently had a problem on-site in which it appeared that a great deal of computer time was being lost in prime shift. That is, when we totalled over a prime shift the figures for lost, null, and overhead, and added these to the time charged to users (from the accounting files), we were consistently short of some 20% of the elapsed time. Stated like that, that's a significant amount of a KL time which was being lost or given away, and we were required to find it.

The site was a 1090 with 512K of MH.

EXPLANATION

The problem primarily comes down to EBOX/MBOX accounting and cache. This was noted by Claude Barbe in Copy'n Mail, in which he concluded that:

"EBOX/MBOX accounting is as good as your cache hit ratio".

Unfortunately, even this is not quite true.

When EBOX/MBOX accounting is used, use of the system is measured by two hardware meters counting micro instructions (EBOX) and memory references (MBOX). This is converted to time by the use of two divisors, which are CPU model dependent.

The MBOX counts all memory references, irrespective of whether the required data was in cache or not. Its' divisor is such that, if a program of the form JRST . is running, then the total time charged (i.e.: null+lost+overhead+user) approximates very closely to 100% of elapsed time. JRST . is completely cache effective.

If a completely cache ineffective program is running (e.g.: a large JRST . +4 loop) then the time charged will be around 18% of elapsed time, which is frightening.

So far this seems to agree with Claude's statement. However, in attempting to map a relationship between cache hit ratio and charged time during prime shift we find that similar cache hit ratios give widely differing charged times, and similar charged times come from different cache ratios.

Part of the reason for this is that a cache hit is two quite different things.

The whole problem condenses rather neatly into two simple programs. Consider:

(A)	(B)
	SETOM (T2)		MOVE T1,(T2)
	ADDI T2,1000		ADDI T2,1000
	AOBJN T3,.-2		AOBJN T3,.-2
 ;outer loop control;	

Now, the program JRST . was 100% cache hit, charging 100% of elapsed time.

Program (A) Here is 100% cache hit, charging 74% of elapsed time.

Program (B) Here is 76% cache hit, charging 53% of elapsed time.

The obvious questions here are:

- Why does (A) at 100% cache effective charge 74% while JRST . charges 100%?
- Why is (A) 100% cache effective and (B) only 76%.
- Why should (A) charge 74%, but (B) charge 53% of elapsed time?

It is best to answer the second question first. All B's (and A's) instructions are in cache since they are at a virtual page offset which does not clash with the page offset of the memory reference, and therefore need never move. B is doing a read every third instruction which always fails to find a match in cache, since there is only space there for four memory locations of page offset 0 (or whatever). Hence, the three instruction fetches +1 memory fetch give us a cache hit ratio of three in every four, or 75%. Program A is the same, but does a write to memory instead. It appears that, because we always put the write in cache we score a cache hit, whether or not it was first necessary to write away valid written data. Hence, a cache hit is now two different things -- no memory reference required on a read, on a write it matters not -- program A is 100% effective, against program B's 76%. (strictly, of course, a cache hit could be consistently defined as the referenced data being put in/got from cache irrespective of whether a memory reference was required, but that differs certainly from my original conception of it).

The clue to the differing charged times came in the ratio 74% to 53%, which nicely matches the ratio of read time to write time for MH memory, i.e.: 1.767 to 1.267. Observe what happens in Program A:

SETOM requires that a valid written word in cache first be put in memory. We must now wait for the memory cycle to finish before we can fetch and execute the ADDI and AOBJN, and fetch the SETOM. All of these come from cache, and do not reference memory. Execution of the SETOM then causes another memory reference, and so on.

Diagrammatically:

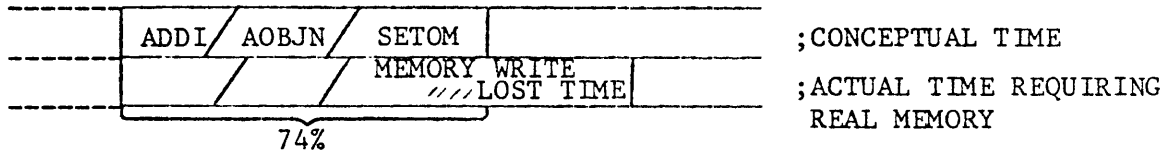

Program B is very similar, but requires a read from memory.

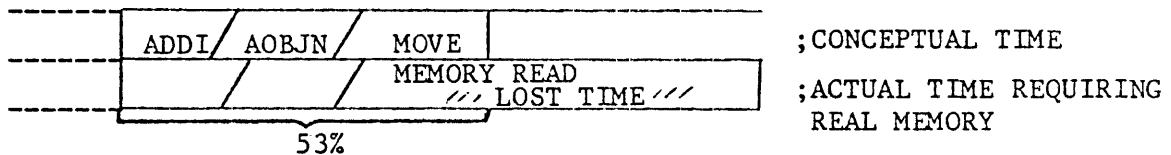

With the much larger memory cycle time involved we charge for an even lower percentage of the real time, 53%.

Obviously, varying these two themes on the cache availability of the instructions, this effectiveness on cache, and whether we read or write, would allow for a totally variable charge range.

WHY EBOX/MBOX?

If EBOX/MBOX accounting causes such problems, why use it? The answer is that it provides beautifully consistent user accounting. Irrespective of system load, time of day or scheduling vagaries, when a user runs a job it will always cost the same amount. This is a good thing, and compares favorably with 'KI' accounting, which may in extreme cases show a factor of 15 difference in charges between a Sunday run and a prime shift run of the same job. Unfortunately, in being so consistent, EBOX/MBOX gives the internal accountants, i.e.: the computer department in whatever form, a real problem. How do they charge for the missing time?

It is my belief that all of these problems are caused by the historical practice of accounting for computer usage by time. The EBOX/MBOX meters provide a consistent, tidy account of CPU usage in digital units, a measure of work done (KLergs?). This is rightly quite independent of prevailing conditions. The real error comes in reducing it to time values. It is a matter for site accountants to fix, by the normal in-house procedures for dealing with overheads, the means of rating KLergs directly in cash terms, taking account of the probability range of the site-specific percentage of 'hidden' time taken by users. They must avoid the unnecessary, and demonstrably illogical, intermediary step of roughing it out in units of time before converting to cash. Monitor and documentation should certainly avoid the same trap, and refer to accounting units as such and never in time units. After all, no one would expect to charge for line printer output on a time basis, using the optimum time required to fill a page.

CONCLUSIONS

- EBOX/MBOX accounting is beautiful and consistent.
- There is a philosophical error in converting EBOX/MBOX units to time.
- Sites selecting EBOX/MBOX should realize and utilize the consistent digital measure of work done returned by the two meters, converting that measure directly into cash independent of time.
- DEC accounting and documentation should match this thinking.

AND...

- A write into cache should only be considered a cache hit if no memory writeback is required.

TROUBLESHOOTING MASSBUS PARITY ERRORS (CBPE OR DBPE) WITH AN RH10

BY: SCOTT SITTERLY
FIELD SERVICE - AMSTELVEEN

Quite often you will get a poorly seated massbus cable or a bad transceiver that will give you a massbus parity error (either a CBPE or a DBPE). To troubleshoot this, you usually do such things as shorten the massbus to determine where the fault lies. What you need is an easy way of reproducing the failure, rather than chase massbus parity errors with a diagnostic. I've found it more convenient to use the RH10's switch panel as follows:

CONTROL-BUS PARITY ERRORS: (PICKED BIT)

- A. Put the RH10 in local.
- B. Set the switches to 020002000000 which will read register 02 of drive 2 (drive select is in bits 15-17).
- C. Hit stop, clear, start.

If you get a CBPE, the bit being picked should be reflected in the DIB register data. If no bits are picked and you have a CBPE then you've dropped a parity bit.

CONTROL-BUS PARITY ERRORS: (DROPPED BITS)

- A. Put the RH10 in local.
- B. Set switches to 024002177777 - switches 0-5 select register 02, bit 5 must = 1 to write to a register, then with switches 15-17 select a drive, say drive 2, then set 20-35 to ones.
- C. Hit stop, clear, and start.

You've just written ones in register 02. To read it back, what I do first, so that I can see the DIB register data change is set the switches to 010002000000 and only hit start. If you hit clear it will clear out the drive, zeroing register 02. You have just read register 01 which will equal something other than all ones.

- D. Now you set the switches to 020002000000 and only hit start. You will read out register 02 and if you get a CBPE you should either see CPA (parity bit) or a data bit dropped.

DATA BUS PARITY ERRORS:

The method I use to check for data bus parity errors is to see if I can read the headers of a pack correctly. To do this, I do a readin-preset to a drive with a pack spinning and then do a read header and data while in local. To do this, do the following:

- A. Put the RH10 in local.
- B. Set the switches to 004002000021 - This will do a write to register 00 of drive 2, the readin-preset command of 21.
- C. Hit stop, clear and start - Now when you do a read you should be reading cylinder 0, surface 0, and sector 0. Also, make sure your VV bit is set (bit 9 of register 01). This bit is reset whenever you power a drive off and on.

Without this bit set you can't read data from the drive.

- D. Now set the switches to 404002000073 - This will start a read header and data command and the first word of the header will be locked in the channel buffer.
- E. Hit stop, clear, and start - Now the channel buffer will reflect the cylinder, surface, and sector of the header you just read.

0-17 = CYLINDER, 18-27 = SURFACE, 26-35 = SECTOR

At this time, all of these will equal 0. However, if you hit start again, bit 35 should come on showing that you just read sector 1.

1. If you keep hitting start you'll count through the sectors, then the surfaces, and finally the cylinders. If you want the RH10 to step through the sectors for you, put the recycle switch on and hit start, it will step through for you.

If you have a picked bit you'll see it when you read cylinder 0, surface 0, and sector 0. If it's a dropped bit and it's not one of the bits used in the header information I'd drop back to the diagnostics.

NOTE: IF YOU WANT TO LEARN MORE ABOUT USING THE RH10'S SWITCH PANEL I WOULD HIGHLY RECOMMEND YOU READING APPENDIX A OF THE RH10 MANUAL STARTING ON PAGE A-4 SECTION A.3.3.1.

Cross Reference: RH10-TT-10

SEARCH ERRORS ON RPO2S OR RPO3S

BY: SCOTT SITTERLY
FIELD SERVICE - UTRECHT

There are two reasons why you didn't get a header compare.

1. You can't read the header.
2. The header you are reading isn't the header that you expected.

An example of item 2 would be when the drive positions the heads to the wrong cylinder or selects the wrong head. It is possible to scope the header coming in, and with delayed sweep you can see how many bits are in the header and their general position. However, this isn't very easy or accurate. You could also attempt to scope the LPR flip-flops where the header is read, but a more convenient way to do it is the following:

- A. Set the switches to point to a cylinder, surface, sector, that is giving you a search error.
- B. Put a jumper from ground to F03 pin R in the RP10. (The output of a B134 on the second DTC page coordinates C/8).
- C. Do a local read.

The assembly register AR lights will reflect what is in the LPR register, which at this time contains the actual header that your reading from the pack. The LPR register should be compared with the data address register to confirm a header compare.

If you see ones and zeros floating through the lights then you have a read problem. If you are reading a header other than the one you want you should be able to determine which bits are different.

Beware if your trying to read cylinder zero and your seeing ones and zeros floating through the AR, your heads might be positioned to cylinder -1. Try a cylinder further out into the pack to see if you are off one cylinder in the negative (-) direction.

EXAMPLE: Seek to 256 and when you read you'll get the header for 255.

The lights will be in the following format:

<u>BIT</u>	<u>MEANS</u>
17	CYL = 256
18	CYL = 128
19	CYL = 64
20	CYL = 32
21	CYL = 16
22	CYL = 8
23	CYL = 4
24	CYL = 2
25	CYL = 1
26	SURF= 0
27	SURF= 1
28	SURF= 2
29	SURF= 3
30	SURF= 4
31	SECT= 0 NOT REALLY USED
32	SECT= 1 SECTOR LIGHTS 1 THROUGH 4 WILL BE
33	SECT= 2 GLOWING UNLESS YOU RUN WITH ERROR
34	SECT= 3 STOP ON AND THEN YOU'LL ALWAYS STOP
35	SECT= 4 ON SECTOR 10

B E W A R E ! ! !

IF YOU FORGET TO REMOVE THE JUMPER WHEN YOU WANT TO READ DATA IT
WILL NOT WORK.

Cross Reference: RP10-TT-7

DN87S - FCO #1
BY: PETER MARIE
M.E.G. - MARLBORO

A problem has surfaced pertaining to the loss of the CTY due to the incorporation of DN87S FCO #1.

Because of misconceptions concerning the purpose of the CTY, customers are complaining of the loss of "their" terminal. The only purpose for the CTY on the DN87 was for use by Field Service for PM/CM on the DN series front ends.

When this FCO was created, a decision was made that it would be beneficial for Field Service and the customer to have both a dial-up capability and an alternate path for performing maintenance on these units. With the capability, it is now possible to perform CM without interfering with the customers system uptime.

This FCO is a required upgrade to be made when upgrading from DN87 configurations. Under no circumstances should any deviations be made from the published FCO. This would mean an illegal configuration and may cause more problems than it is worth.

Also of importance is that Version 12 (40) of RSX20F is needed to facilitate successful completion of this FCO. If needed, it can be obtained from the:

SDC (SOFTWARE DISTRIBUTION CENTER)
MAYNARD, MA 01754
ML11-3/E52

by ordering the following DECTAPES:

1	DEC-10-OTMAA-B-UB	TOPS10 RSX20F AUX DT
1	DEC-10-OTMMA-E-UB	RSX20F DT

Cross Reference: DN87S-TT-7

KLAD10 REV 12/4 TOPS10 MONITOR

BY: RUSS MYERS
FIELD SERVICE - KANATA

If you have not already noticed, the TOPS10 monitor shipped with the REV 12/4 KLAD10 has a few problems.

One of these problems is that the copy of QUASAR.EXE in SYS: gets a COP stopcode when it is started (see the OPR.ATO dialogue at system startup time). Without QUASAR, of course, you will be unable to run LPTSPL, BATCON or any other "GALAXY" system program.

As running batch jobs under the KLAD monitor is desirable (i.e.: for running ACCEPT or for "load" testing) I have found it necessary to correct the problem with QUASAR. The reason for the COP stopcode is that when the GALAXY system was built, DSKB was specified as the primary Que device.

Under normal circumstances, however, KLAD is the only structure mounted while running the KLAD10 monitor, therefore, the primary Que device must be changed. One way of doing this is to follow the prolonged GALAXY build procedure outlined in Software Notebook #4.

Another alternative is to edit/patch the copy of QUASER to specify KLAD as the primary Que device. This can be done using the following procedure:

- (1) log into [1, 2] ; work area
- (2) .COPY = SYS:QUASAR.EXE ; copy Quasar to work area
- (3) .R FILDDT ;
FILE: QUASAR/P ; patch Quasar
- (4) \$\$6T ; 6 bit type out mode
- (5) 12021/DSKB ; open location where primary Que device is stored
- (6) \$/KLAD/ ; change to KLAD
- (7) ^Z ; exit

Now the copy of QUASAR.EXE in [1, 2] has been patched. All that is left is to copy this patched version into SYS: (deleting the old copy).

This procedure has been tested using the monitor supplied on the field distribution tapes for a 1090 system. If there are any problems with this patch, or if you have any questions regarding the KLAD10 monitor, I can be contacted in Kanata,

PHONE: (613) 592-5111 X2200 DTN: 621-2200

CORRECTION
SITE PREPARATION GUIDE
BY: ROY SEQUEIRA
PRODUCT SUPPORT - MARLBORO

The power cord connector for the MH10/MG10 has been specified incorrectly as a 20 amp type. The correct NEMA number is:

L5 - 30P

The power cord connector for the LA36/LA37/LA180 has also been specified incorrectly. These units use standard wall plugs similar to 5-15P.

Please correct your Site Preparation Guides accordingly.

OPTION JUMPERS
BY: KEN LAPRADE
IHFS - MAYNARD

There is an error in Volume 1 of the KL10 Handbook concerning option jumpers.

One page 3 of the switches and jumpers section, the pin listed for Bit 128 of the CPU serial number is 4E41E1. THE CORRECT PIN FOR THAT BIT IS 4D41E1.

SUBMITTING A TECH TIP
 BY: NANCIE MITCHELL
 MEG/LSG SYSTEMS SUPPORT - MARLBORO

When you submit a Tech Tip to Marlboro for microfiche publication, please submit it on a Field Service Technical Manual Form (*). It is also a requirement that the information submitted be approved and signed by your Manager/Supervisor.

An example of the header page is below. Please fill out as much of this information as possible when submitting a Tech Tip. It will help me greatly!

FIELD SERVICE TECHNICAL MANUAL (HEADER)

Title				Tech Tip Number	
Author		F.S. Office	Date	Revision	
Processor Applicability		Mgr./Sup.	Date	Cross Reference	
All		Approval:	Date		

*Cross Reference: Good Stuff #18, May FY'79, Page 14.

LOADING .A11 OR .BIN IN SECONDARY FRONT ENDS

BY: LARRY MIDURA
 M.E.G. -- MARLBORO

When loading .A11 or .BIN files in a secondary front end you must specify the complete FILENAME.EXT or else you will receive an error message which says:

```
FE1>. FE
FE1>. P DGDTE
DGDTE BEING TRANSMITTED
DGDTE.A11  VER 1.10  17-OCT-77
?LOAD CHR ERR: LOAD LINE 1.
?LOAD CHR ERR: LOAD LINE 1.
?LOAD CHR ERR: LOAD LINE 1.
?LOAD CHR ERR: LOAD LINE 1.
ABORT
CAN'T LOAD
```

DATA MISSED ERRORS WITH CR10E ON A 1090 SYSTEM

BY: BEN BOSKLOPPER
FIELD SERVICE - AMSTELVEEN, HOLLAND

Have you ever encountered data missed errors when using the CR10E cardreader?

The logic analyzer shows that this happens when there are many PIO interrupts (from DTE's) at the same time. The BLKI instruction is not acceptable, so we replace it by a DATAI instruction which is shorter in time.

We use the following patch:

```
CDRINT+7/ XCT CDRBKI(F) JRST PAT+130

PAT+130/MOVEM U, CDRSV2(F) ; SAVE U
PAT+131/MOVE U, CDRSUP(F) ; GET POINTER TO STORE DATA
PAT+132/AOBJP U, .+1 ; INCRE, POINTER
PAT+133/MOVEM U, CDRSUP(F) ; STORE POINTER
PAT+134/HRRZS U, ; GET ADDRESS TO STORE DATA
PAR+135/DATAI CRO, (U) ; DO INPUT
PAT+136/MOVE U, CDRSV2(F) ; RESTORE U
PAT+137/SKIPL CDRSUP(F) ; WAS POINTER EXPIRED?
PAT+140/JRST CDRINT+10 ; YES
PAT+141/JRST CDRINT+11 ; NO
```

A Software Performance Report has been submitted to Marlboro regarding this problem.

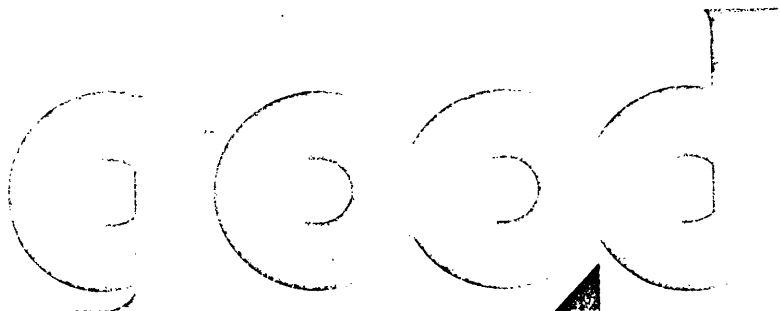

stuff

COMPANY CONFIDENTIAL

This document contains sensitive information which shall not be disclosed to personnel outside of Digital Equipment Corporation.

This Newsletter is meant as an information document. Its contents are not necessarily Company Policy. It's a means by which LCG Product Support can distribute some trobits of information to you.

IN THIS ISSUE ...

● DIAGNOSTICS

- PROBLEM WITH INITIALIZATION DIALOG OF DIAGNOSTIC DFTUK.A10 VERSION 0.2 Page 3
- DIAGNOSTIC LOADING OF SECONDARY FRONT ENDS (DTE 1, 2 OR 3). Page 4
- RUNNING VOLTAGE MARGINS ON KI10. Page 4

● HARDWARE

- FCO DN87S-R-0001 CHANGES Page 5
- UPGRADE TO BIOMATION 1650-D LOGIC ANALYZER Page 5
- EXERCISING BACKPLANES. Page 6
- RP05/RP06 CONTROL PANEL PROBLEMS AND DCL PRINT SET ERRORS Page 7
- NEW RED PACK RELEASE Page 7

● KLAD

- CORRECTION - HOW TO PATCH .A10 FILES ON KLAD10 PACKS . . Page 8

● MISCELLANEOUS

- FEEDBACK Page 10
- INSTALLATION FEEDBACK FORMS. Page 10
- CAN YOU BEAT THIS! Page 11
- NEW SYSTEMS Page 12

● SOFTWARE

- KI10 CONSIDERATIONS FOR TOPS-10 VERSION 7.01 Page 13
- PARITY ERRORS WHILE READING BAD TAPE THROUGH A TM02. . . Page 13
- DL10'S ON SMP SYSTEMS. Page 14
- THE HOMEBLOCK PROBLEM. Page 15
- TOPS-10 KL MICROCODE VERSIONS. Page 15

● SUPPLEMENT:



ANY FIELD SERVICE EMPLOYEE (700 COST CENTERS ONLY) WISHING TO BE ADDED/DELETED TO THE GOOD STUFF DISTRIBUTION LIST MUST SUBMIT A MEMO OR TWX TO:

NANCIE MITCHELL
MR1-1/S35
DTN: 231-5148
TWX CODE: MR11

WITH THE FOLLOWING INFORMATION:

- YOUR NAME
- BADGE #
- COST CENTER
- LOCATION CODE
- ADDED DELETED

ALSO, SEND ANY ARTICLES WHICH YOU FEEL SHOULD APPEAR IN GOOD STUFF TO:

GOOD STUFF EDITORIAL OFFICE
c/o NANCIE MITCHELL
MR1-1/S35
DTN: 231-5148
TWX CODE: MR11

EDITOR NIGEL WEBB
ASSOC. EDITOR. .NANCIE MITCHELL
EDITORIAL OFFICE . . .MR1-1/S35

GOOD STUFF is published on a monthly basis.

PROBLEM WITH INITIALIZATION DIALOG
OF DIAGNOSTIC DFTUK.A10 VERSION 0.2

BY: L.S. MANCHESTER
FIELD SERVICE - FARMINGTON HILLS

While starting DFTUK.A10, Version 0.2, during timesharing, under TOPS-20, Version 4, two questions from the diagnostic dialog are suppressed. The two questions are:

1. "IS CONTROLLER TM03?"
2. "TYPE MTAPE TO BE TESTED IN THE FORM "MTAN:"(CR)-"

These questions are only suppressed when the left hand diagnostic switches have bit 03 set (NOPRT). All normal dialog questions that follow these two missing questions are printed correctly. This "bug" causes a large amount of confusion and wasted time, as the diagnostic appears to be "hung", while it is really waiting for responses to the two un-outputted questions. This problem does not occur if the left switches do not have the "No Print" (NOPRT) switch set.

This problem can be circumvented by merely answering the two un-outputted questions. See examples:

GOOD OUTPUT

RUN DIAMON

* D20MON DDQDH - DECSYSTEM20 DIAGNOSTIC MONITOR - VER 0.2

D20MON CMD - DFTUK

DFTUK.A10 VER 0.2 15-MAR-79

VERSION 0.2, SV=0.15, TOPS-20, KL10, CPU#=2157

TTY SWITCH CONTROL? - O,S,Y OR N (CR) - N

SWITCHES = 000000 000000

MEMORY MAP =

FROM	TO	SIZE/K
00000000	00103441	33

IS CONTROLLER TM03? Y OR N (CR) - N

; this is correct dialog

TYPE MTAPE TO BE TESTED IN THE FORM "MTAN:(CR)" - MTA2: ; correct again

SLV TYPE (TU16, TE16, TU45 OR TU77):TU45

etc.

.

.

CONT. NEXT PAGE →

BAD OUTPUTRU DIAMON

* D2OMON DDQDH - DECSYSTEM20 DIAGNOSTIC MONITOR - VER 0.2 *

D2OMON CMD - DFTUK

DFTUK.A10 VER 0.2 15-MAR-79

VERSION 0.2, SV=0.15, TOPS-20, KL10, CPU#=2157

TTY SWITCH CONTROL ? - 0,S, Y OR N (CR) - Y

LH SWITCHES (# OR?) - 40000 ; set NOPRT

RH SWITCHES (# OR ?) - 2000

SWITCHES = 040000 002000

Y OR N (CR) - N ; this is the TM03 question

MTA2: ; this is the drive number question

SLV TYPE (TU16, TE16, TU45 OR TU77):TU45

etc.

.
.
.

NOTE: An AIDS Report has been submitted and Diagnostic Engineering is aware of the problem.

DIAGNOSTIC LOADING OF SECONDARYFRONT ENDS (DTE 1, 2, OR 3)

BY: LARRY MIDURA

M.E.G. - MARLBORO

After loading and booting a secondary front end and getting to the FE"X">. prompt (where "X" is front end 1,2, or 3), in order to transmit files across you must use the full FILE.EXTENSION in order for it to be successful. This is only necessary for .A11 and .BIN files but not .A10 files.

RUNNING VOLTAGE MARGINS ON KI10

BY: ROY SEQUEIRA/RICK JEVONS

PS MARLBORO/A.S.M.

To run margins on the KI10 using the KICPU.CMD string, including DBKAA through DBKAI, put a NOP at location XPNRN3 in DIAMON to eliminate a call that clears the ACS. This is to be done in conjunction with the X command to DIAMON.

FCO DN87S-R-0001 CHANGES

BY: JOE SWEENEY
M.E.G. - MARLBORO

1. There has been feedback from the field questioning the use of the BR5 grant plug noted in FCO DN87S-R-0001, Page 2 Item 2, and Page 5 item 7.

A BR5 grant plug is specified and is recommended, however, a BR4 grant plug will work in this application.

2. FCO DN87S-R-0001, Page 4 item 3, contains an incorrect device address:

INCORRECT - DN87-S#3 = 776750 (DTE#3)

CORRECT - DN87-S#3 = 775650 (DTE#3)

Cross Reference: DN87S-TT-8.

UPGRADE TO BIOMATION
1650-D LOGIC ANALYZER

BY: STEVE DAIL
MASS STORAGE MAINTAIN ENG.

The Bionation Logic Analyzer will be required as a support level tool for the RP07 disk drive. The existing field units (Biomation 1650-D's) will require upgrading to provide data domain capability (inclusion of the 116 Data Domain Option). The options have been ordered and will be "force fed" to the locations that currently have 1650-D's.

The goal is to have the upgrade complete during Q1 FY'81.

EXERCISING BACKPLANES

BY: BOB MCKINSTRY

L.S.G. PRODUCT SUPPORT - MARLBORO

There is a high incidence of Field Service people "exercising" backplanes with credit cards or other such items. This is a totally unacceptable procedure in troubleshooting suspected backplane problems.

The damage that may be induced by this action takes place because of the architecture of the KL backplane, and the hardware used there. We all know how dense the wiring is in the KL, which makes the chance of damage much greater.

First, the pins used are square pins, with four distinct, sharp edges. The points, or ends of these pins, are also very sharp. That brings us to the wire, which is wrapped around, or passes above these pins. The insulation on this wire is not one continuous piece of plastic, but instead, a thin "strip" that is "wrapped" around the wire, much like you would wrap a bandage around an injured arm or leg. The overlap area on these wraps is very small.

Now, with a little imagination, we can visualize one of these overlap areas laying against one of the sharp pin corners, or tips. A Field Service person comes along with a credit card and violently vibrates said pin. It works its way through the wrap of insulation, and touches the metal of the wire!

There is another reason why we should never do this. Many of the connections made in the KL backplane are soldered etched connections. Vibrating any solder joint is not good, and because of space limitations, the amount of solder on etch pin connections is limited. We all know what a hassle broken or cold solder joints can be!

There are correct ways to troubleshoot suspected backplane problems WITHOUT adding more problems to the machine. If you have such a problem, and are not sure how to go about it, feel free to ask your support groups for help. And remember, Product Support maintains special tools and personnel to help in these situations.

RP05/RP06 CONTROL PANEL PROBLEMS
AND DCL PRINT SET ERRORS

BY: LEE BRODEUR
DISTRICT SUPPORT - MERIDEN

There is a problem with the RP05/RP06 operator control panel.

The problem causes the file ready signal to the DCL to come and go intermittently resulting in spurious attentions being generated. Our experience indicates that after replacing the control panel, the drive ran okay until the operator panel was lowered to the closed position. The ready signal would go away when the panel was lowered. This was caused by the IC pins on the rear of the control panel shorting to the ground plane on the MDLI cables when the control panel was lowered.

There are also some errors on the M7776 board in the DCL print set. On the ECO page at coordinates C and D 8 there are two errors in signal designations. On pin 5 of E87, the signal RG3 RD HD DAT COM L is shown as entering the board on pin CS1, the pin is really CS2 as verified through the wire lists. Also, the signal SNO SYNC CLK ENA H on pins 1,2, and 9 of E41 that enters the board on pin DS1 originates on the SN1 drawing, not on the DNO drawing.

NOTE: An AIDS Report has been submitted to Maynard regarding the above problem.

NEW RED PACK RELEASE

BY: JOE HOLEWA
M.E.G. - MARLBORO

All 2020 system shipments coming from Marlboro after 1-May-80, will be shipped with Red Pack Version 404 and the supporting Red Tapes 1 and 3 (except OEM customers). This Red Pack release will contain the TOPS20 Release 4 software, new 2020 diagnostics (DSTUA and others), and new Red Pack documentation.

For the support of the current 2020 systems already installed in the field with Red Pack Version 303, we will be distributing the new Red Tapes 1 and 3, at a rate of at least one set per Branch. At that time, we will be furnishing additional information on how to order the new Red Tapes. This will occur early in May '80.

NOTE: After you have built your new Red Pack read the document BEWARE.MEM in the area PS:<RED> on the Red Pack.

CORRECTION ***** CORRECTION ***** CORRECTION
HOW TO PATCH .A10 FILES ON KLAD10 PACKS

BY: DAVE ROBERT
DIAGNOSTIC ENGINEERING - MARLBORO

This article originally appeared in Issue No. 25 - December
FY'80. Please make note of the following corrections.

ON PAGE 10...

six-lines down it reads;

YOU ARE NOW INSERTING THE PATCH.		

<u>.DDT</u>		
<u>VMDDT</u>		
<u>40167/</u> LSH 2,-1	<u>=242100,,77777</u>	<u>240100,,777774</u>
<u>40170/</u> TLO 2,400000	<u>=661100,,400000</u>	<u>603100,,17</u>
<u>40171/</u> ASH 2,-3	<u>=240100,,77775</u>	<u>240100,,4</u>

Delete the above section and replace it with the correction on
the next page.

CONT. NEXT PAGE →

CORRECTION:

YOU CAN USE DDT TO FIGURE OUT THE NUMERICAL VALUE OF THE PATCH.

.DDT

<u>43147/</u>	<u>JRST PATCH=254000,,71436</u>
<u>PATCH/</u>	<u>CAIE AC1,54=302340,,54</u>
<u>PATCH+1/</u>	<u>JRST 43120=254000,,43120</u>
<u>PATCH+2/</u>	<u>TLO AC2,2000=661400,2000</u>
<u>PATCH+3/</u>	<u>37200,,PATCH+10=37200,,71446</u>
<u>PATCH+4/</u>	<u>JRST 43152=254000,,43152</u>
<u>PATCH+10/</u>	<u>106465,,272711=106465,,272711</u>
<u>PATCH+11/</u>	<u>770000,,0=770000,,0</u>

PRESS CTRL 'C'

YOU NOW WANT TO DEL THE DDQCB.SAV FILE, BECAUSE YOU NOW HAVE THE NUMERICAL NOTATIONS FOR THE PATCH.

RUN THE CONVRT PROGRAM AS BEFORE, THEN DO A
GET DDQCB.SAV

YOU NOW WANT TO INSERT THE PATCH INTO THE PROGRAM USING MONITOR.

DO A DEPOSIT

	LH	RH	ADDRESS
D	<u>254000</u>	<u>71436</u>	<u>43147</u>
D	<u>302340</u>	<u>54</u>	<u>71436</u>
D	<u>254000</u>	<u>43120</u>	<u>71437</u>
D	<u>661400</u>	<u>2000</u>	<u>71440</u>
D	<u>37200</u>	<u>71446</u>	<u>71441</u>
D	<u>254000</u>	<u>43152</u>	<u>71442</u>
D	<u>106465</u>	<u>272711</u>	<u>71446</u>
D	<u>770000</u>	<u>0</u>	<u>71447</u>

IF YOU WANT TO EXAMINE THE LOCATIONS THAT YOU JUST PATCHED, DO AN
 EXAMINE E 43147 THIS WILL TELL YOU WHAT IS AT THAT ADDRESS.

FEEDBACK
BY: JERRY GANNELLI
INSTALLATION QUALITY

Chriss Aubuchon is the manufacturing coordinator for short ships and feedback here in Marlboro. She has written a memo requesting more feedback which I would like to pass along to all of you.

All feedback gets reviewed and addressed. We send a copy of each feedback form received, to Manufacturing. Sometimes we get a response, and sometimes we don't! Chriss is going to try to change that, but she needs our help. For her to establish recurring problems, and justify her own efforts, she's going to need more feedback. She's going to need to hear the good news as well as the bad. If we're doing something right and don't hear about it, you know darn well it's only a matter of time before someone changes it.

We need your inputs; we need your feedback. Keep it coming.

Chriss's memo 

INSTALLATION FEEDBACK FORMS

BY: CHRISS AUBUCHON
QUALITY CONTROL

Marlboro Manufacturing receives installation feedback forms on approximately 20% of the systems shipped. This is not a high enough percentage to measure the quality of systems shipped.

We intend in the near future to begin analyzing these feedback forms, hoping to monitor trends and flag reoccurring problems. We also intend to report to the submitter of the feedback form any information pertaining to the problems highlighted on the form.

The above mentioned cannot be achieved until 50% or more of the feedback forms are returned. It is my belief that with the cooperation of Field Service and Manufacturing we can improve the quality of outgoing shipments and reduce installation down-time.

As always your comments and suggestions are welcome.

CAN YOU BEAT THIS!

A DECSYSTEM-2050, located at Amoco Research, Chicago, has set a new record for the greatest number of uninterrupted crash free hours:

1,322 CRASH FREE HOURS

SOME BACKGROUND ON THE SYSTEM:

This system is a 2050 with two, TU45's; three, RP06's; 384K of memory, and a DN20, LP05 printer. P.M.'s are done bi-monthly, although, not during this unprecedented stretch.

Their application involves mostly scientific calculations relating to chemical research.

THE PERSON RESPONSIBLE IS:

MARK BASTEN - FIELD SERVICE ACCOUNT REPRESENTATIVE

***** CONGRATULATIONS MARK *****

Again, if you have a system in your Branch that beats this record let us know. You should get the recognition you deserve.

NEW SYSTEMS

BY: PETER MARIE
M.E.G. - MARLBORO

As you the field personnel, may or may not be aware, the Corporation through its' maintainability functions use the LARS data. The LARS data which you input via the LARS reports is used to evaluate a specific options failure rate (MTBF), repair time (MTTR), and other "trends" in maintainability or performance. The figures are used to correlate the projected values which were made prior to First Customer Ship (FCS) of new options/systems.

To use the data contained in the LARS data base, it is necessary to "sort" by specific "fields", which coincide with those entries on the LARS report itself.

In order for this data to be more meaningful, and thus enabling us to better prepare for the next generation of equipment, there is a requirement for this data to be more specific.

In light of the above, it would be greatly appreciated if the "comment" field on the LARS report was completed in the following manner, which is, only a further definition of what is stated in the LARS manual. The basic theme is to identify the failing FRU (Field Replaceable Unit)/component by its' generic name and put this information in the comment section.

EXAMPLE 1: Single module replacement

EXAMPLE 2: Multiple module replacement

EXAMPLE 3: 29/70/50 class part replacement

EXAMPLE 4: Adjustments (power, skews, memory, etc.)

EXAMPLE 5: DN2X (note module shown using PDP11 nomenclature)

The "test" field can be, (if approved by your Branch Manager or Supervisor) used as a descriptor for the System Software failure mode when applicable (see examples).

It would be appreciated if, when completing your next LARS report, you incorporate the above format, as this information will help to enhance future product maintainability features.

	DEC OPTION	VARIANT	DEC OPTION SER. NO.	TYPE OF CALL	ACTION TAKEN	FAIL AREA - MODULE - FCO - COMMENTS	AUTHORIZED TESTS
EX #1	2 0 5 0	- B A	1 1 2 6	C	C	M 8 5 1 4	F A T C D P
EX #2	R H 2 0	-		C	C	M 8 5 5 5 / 5 6 / 5 7	P H 2 D N A
EX #3	R P 0 3	-	3 3 0	C	C	2 9 - 1 9 0 1 7	
EX #4	M B 2 0	- G A		C	A	M 8 5 6 5 - A D J	A P R N X 1
EX #5	K M C 1 1	- A		C	C	M 8 2 0 4	

KI10 CONSIDERATIONS FOR TOPS-10 VERSION 7.01

BY: ERNIE RACINE
TOPS-10 PROGRAM MANAGER

TOPS-10 Version 7.01 will be the last release of the Operating System to support the KI10 processor. This release will require a separately purchased option for use on all dual processor systems. This option is not intended to expand KI configuration capabilities beyond what currently exist. Fully symmetric KI10 configurations will not be supported. The basic KI processor speed and the fact that it does not have cache has meant that dual KI systems have not been significantly limited by having all I/O gear on a single CPU. For that reason we are not offering any form of I/O equipment connected to the second CPU.

The dual CPU option will yield a performance improvement over 6.03A as the Operating System calls (UUOs) can be handled by either CPU. This eliminates a major source of overhead associated with the master/slave implementation. An extremely efficient queued protocol has been developed which will allow requests for I/O to be quickly passed to the CPU having the I/O equipment.

PARITY ERRORS WHILE READING
BAD TAPE THROUGH A TMO2

BY: LARRY MIDURA
M.E.G. - MARLBORO

If you are running TOPS20 Release 3A or earlier and are experiencing memory parity error's while reading bad magtapes through a TMO2 tape controller, this problem has been identified and corrected in Release 4.0 of TOPS20.

Tentative release of 4.0 is:

15 APRIL 1980

DL10'S ON SMP SYSTEMS
BY: ERNIE RACINE
TOPS-10 PROGRAM MANAGER

DL10 based communications equipment is only supported on one CPU (the boot CPU) of an SMP system. This means that fully symmetric systems cannot be built using DL10's. Sites requiring the improved availability resulting from dual communications front ends should use DTE based equipment.

For Example:

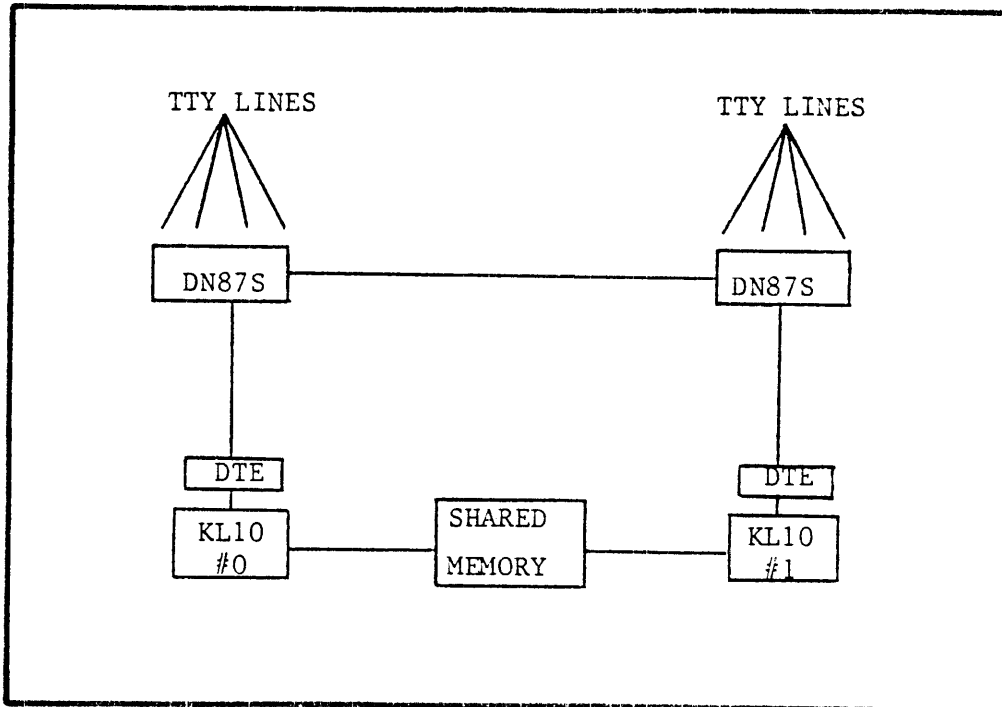

THE HOMEBLOCK PROBLEM

BY: JOE HOLEWA
M.E.G. - MARLBORO

A disk structure mounting problem has been found on 2020's running TOPS20 Release 4. If your PTYCON.ATO file on the your public structure defaults to mounting declared known structures you might see the following problem:

NOTE: Red Pack V.404 exhibits this problem!

PROBLEM:

If a disk drive is on-line during system start-up with bad homeblocks it might cause a different on-line drive with good homeblocks to have problems mounting. For example, if you have your PTYCON.ATO file set up to mount the structures USER: and USER1: at system start-up time, and have another disk drive on-line which has not yet been created into a structure, it might cause USER: or USER1: to have problems mounting.

One way to get around the problem is to not bring the drive with the bad homeblocks on-line until the system has completely finished starting up.

TOPS-10 KL MICROCODE VERSIONS

BY: DON DOSSA
MR1-2/E18

I have received several requests for help on isolating hardware problems that appear on KL CPUs. These problems take the form of AR/ARX data parity errors, memory parity errors and noninterruptable microcode loops. All of the problems have been caused by sites running microcode versions which are between versions 212 and 231. (Not less than 212).

The following table describes the appropriate microcode for Model A's and Model B's.

	<u>MODEL A</u>	<u>MODEL B</u>
6.03A	157	212
7.00	231	231
Release 3A	212	212
Release 4	231	231

All other versions contain potentially catastrophic bugs and absolutely no sites should be running these intermediate versions.

NOTE: This article originally appeared in the Large Buffer, Vol. 501, 6-MAR-80

GOOD

STUFF

COMPANY CONFIDENTIAL

This document contains sensitive information which shall not be disclosed to personnel outside of Digital Equipment Corporation.

This Newsletter is meant as an information document. Its contents are not necessarily Company Policy. It's a means by which LSG Maintainability Engineering can distribute some tidbits of information to you.

IN THIS ISSUE ...

● DIAGNOSTICS

- CAUTIONPage 3
- DIAMON V0.14 AND TOPS10Page 3
- DSTUA (VERSION 0.3)Page 3

● HARDWARE

- TU56 MOTOR CONTROL BOARD: G848.Page 4
- CORRECTION - EBOX/MBOX ACCOUNTING AND THE CLOCK ON THE WALL.Page 4
- RP06 PROBLEMSPage 4
- LP07 PIVOT ARM.Page 5

● MISCELLANEOUS

- SOME HINTS ABOUT PAGE FAIL UNDER DIFFERENT MICROCODE. . .Page 6
- DRIP SCREENS.Page 7

● SOFTWARE

- IBMCON DN6X STATISTICS LOGGER FOR TOPS20 RELEASE 4. . . .Page 8
- SYSERR V14 (1270) AND YOUR 2020Page 8
- SOME USEFUL INFORMATION WHEN YOU ARE LOOKING FOR DISK AND TAPE BEHAVIOR IN A TOPS20 CRASH DUMP.Page 9

● SUPPLEMENTS:

- MF20 ARRAY BOARD REPLACEMENT POLICY
- ANNOUNCING TOPS-20 RELEASE 4

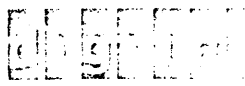

ANY FIELD SERVICE EMPLOYEE (700 COST CENTERS ONLY) WISHING TO BE ADDED/DELETED TO THE GOOD STUFF DISTRIBUTION LIST MUST SUBMIT A MEMO OR TWX TO:

NANCIE MITCHELL
MR1-1/S35
DTN: 231-5148
TWX CODE: MR11

WITH THE FOLLOWING INFORMATION:

- YOUR NAME
- BADGE #
- COST CENTER
- LOCATION CODE
- ADDED DELETED

ALSO, SEND ANY ARTICLES WHICH YOU FEEL SHOULD APPEAR IN GOOD STUFF TO:

GOOD STUFF EDITORIAL OFFICE
c/o NANCIE MITCHELL
MR1-1/S35
DTN: 231-5148
TWX CODE: MR11

<p>EDITOR NIGEL WEBB ASSOC. EDITOR. .NANCIE MITCHELL EDITORIAL OFFICE . . .MR1-1/S35</p> <p>GOOD STUFF is published on a monthly basis.</p>
--

" C A U T I O N "

BY: ALI BAKHTIARI
LSG PRODUCT SUPPORT - MARLBORO

Do not try to run peripheral diagnostics and peripheral related diagnostics (e.g.: DDQCB) under CR1 and CR2 on KL10 based systems.

The diagnostics will fail in different ways and you may waste your time troubleshooting a failure which is not a hardware malfunction.

DIAMON VO.14 AND TOPS10

BY: J. ANDRUSZKIEWICZ/T. KILPATRICK
WESTERN REGIONAL SUPPORT

In order to successfully run DDRPI under TOPS10, DIAMON VO.14 must not be able to find/read the SUBUSR . A10 file. An illegal instruction halt at PC=3746 will always result. Suggest that said file be renamed/deleted from the 6,10 area of your KLAD.

DSTUA (VERSION 0.3)

BY: M.F. MARTI
LCG MAINTAINABILITY ENGINEERING

It has been found that DSTUA will halt if the "RELIAB" switch is "ON" in version 0.3. No other problems have been encountered.

The problem is being addressed and a fix is planned for the next release of DSXLA. A release date has not been determined for version 0.4.

NOTE: An AIDS Report has been submitted to Diagnostic Engineering regarding the above problem.

TU56 MOTOR CONTROL BOARD: G848

BY: BOB BRISTER
IHFS - MAYNARD

You may run into a problem with your TU56, when you find you need to replace one of the G848 "Motor Control" boards.

If your TU56 is using the older revision dual height G848's and you need to replace one, the new revision modules which are a triple height module are not compatible with the old modules. You must replace all four of the older modules in both units for both units to work. This is needed for proper sharing of current.

NOTE: See FCO-G848-Boo8A

CORRECTION CORRECTION CORRECTION
EBOX/MBOX ACCOUNTING AND THE
CLOCK ON THE WALL

In the article published in Good Stuff #28, April FY'80, the second variable for the time accounting was incorrect. It was reported to be M.EMPS when it should have been M.MBPS. This mistake would not have been reported by MONGER since MONGER has no way of knowing what these symbols should be.

Thus the correct values are,

M.EBPS, 15000000 (fifteen million)
M.MBPS, 11700000 (eleven million,
seven hundred thousand)

RP06 PROBLEMS

BY: BOB BRISTER
IN HOUSE FIELD SERVICE - MAYNARD

Recently, I have come across two RP06 problems which were related to the same thing. One of the drives would intermittently unload and load heads. The other drive would not lock on port (either port) and would also hang the bus.

The problem in both cases was that AC or DC Low on one of the DCL power regulator boards was bad. The front regulator caused the unload problem and the rear regulator caused the port problem.

One way to find out which regulator is the bad guy is to pull the yellow wire (AC Low), and the violet wire (DC Low) from P2 on the front regulator (this is the easiest to get to). Then go to the Power Monitor board and check AC and DC Low on P11. If AC and DC are okay, then the front regulator is bad. If AC or DC is still bad, then the rear regulator or the monitor board itself is bad.

SIGNALS SHOULD BE

AC low-High
DC Low-High

Power ok-High
Control Gnd.-Low

LP07 PIVOT ARM
 BY: BOB BRISTER
 IN HOUSE FIELD SERVICE - MAYNARD

When replacing the ribbon skew "pivot arm" on the LP07, one thing that you must be sure of is that the two nylon bearings that fit into the pivot arm cam, are in place. The reason for this is that the new pivot arm is shorter than the old one and this causes the cam to land across both ribbon reverse bars. If the nylon bearings are not in place, the cam will be at a ground potential and will short the two reverse bars.

The problem occurs when the ribbon reverses to start moving up. Now, because of the shorting action of the cam, the ribbon tries to reverse in the other direction and the ribbon gets hung up trying to reverse in both directions at the same time. This, of course, plays havoc on the ribbon.

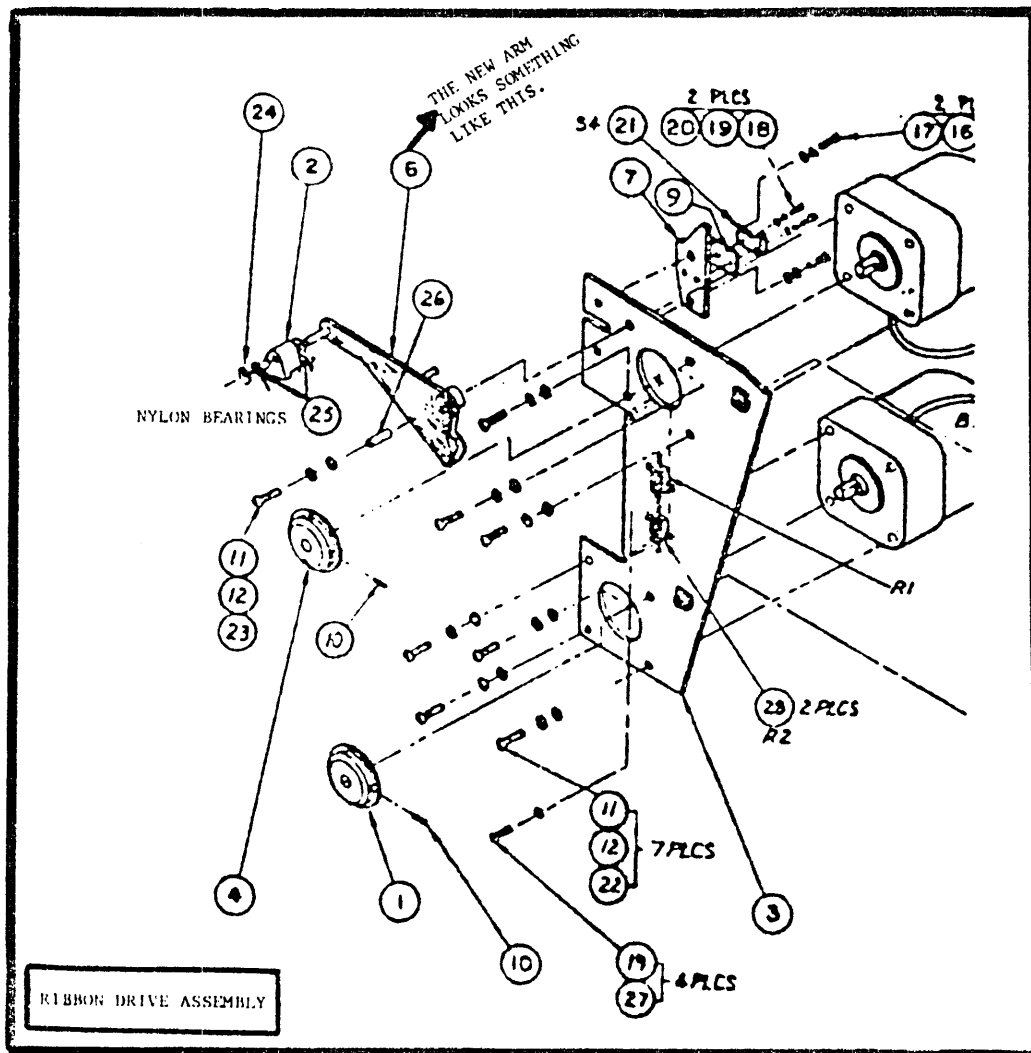

SOME HINTS ABOUT PAGE FAIL UNDER DIFFERENT MICROCODE

BY: ALI BAKHTIARI
 LSG PRODUCT SUPPORT - MARLBORO

First, I should mention that TOPS20 uses KL-paging style and TOPS10 uses KI-paging style.

Second, we should know what different flavor of microcode is used on different machines:

<u>MICROCODE FLAVOR</u>	<u>USED ON</u>	
U.MCR	MODEL A	TOPS10
UB.MCR	MODEL B	TOPS10
KLL.MCR	MODEL A	TOPS20
KLX.MCR	MODEL B	TOPS20

The table below shows you the differences between the flavors of microcode for handling page fail.

<u>MICROCODE FLAVOR</u>	<u>PAGING STYLE THEY USE</u>	<u>LOCATION WHICH HAVE INFORMATION</u>
U.MCR UB.MCR	KI	AR: AC BLK7 WDO ARX: AC BLK7 WD1 IOPF: AC BLK7 WD2
KLL.MCR KLX.MCR	KL	AR: AC BLK6 WD16 ARX: AC BLK6 WD17 WORD WITH BAD PARITY: AC BLK7 WDO PFW: AC BLK6 WD12 IOPF: AC BLK7 WD2

DRIP SCREENS

BY: JERRY GANNELLI
INSTALLATION QUALITY - MARLBORO
MR1-1/S35

It is usually awkward, if not impossible to route cables when a drip screen is in use. Floor cut-outs have to be planned properly, cables have to be labeled properly, and I'm sure it seems installations would go a lot smoother without drip screens in the way.

But...drip screens are there for a reason. They are a minimum requirement for safety. Their presence is essential for UL/CSA approval of options or systems. So, if a drip screen is omitted by a Field Engineer, that engineer has voided all UL/CSA listings and certifications. Should any mishap occur, Digital is liable, and very open to litigation by the Customer. This is not a very good position for Digital, or the Field Engineers to find themselves in. PLEASE use drip screens. If there is a problem in trying to utilize them, notify your Regional Support Group and RIQC. Also, write an AIDS Problem Report, and notify me in writing as soon as possible.

Drip screens for MG10's and MH10's were put in place in 1978 for UL and CSA requirements. There appears to be a problem where these drip screens cannot be properly used. This is currently under evaluation by Engineering and Product Safety. I'll let you know what happens.

IBMCON DN6X STATISTICS LOGGER
FOR TOPS20 RELEASE 4

BY: PETER MIERSWA/LARRY MIDURA
NCSS/MEG

The DN64 software available with TOPS20 Release 3A automatically made entries in the system log file, ERROR.SYS, providing notification of the enabling and disabling of lines and periodic statistics reports. In Release 4 of TOPS20 the DN6x software has been integrated into Galaxy, but the code to enter statistics into the system error file was not included. The program IBMCON provides this service in Release 4 of TOPS20 for both the KS and KL processors.

On KS based systems with RED404 the files IBMCON.EXE and IBMCON.HLP can be found in the area:

PS:<UNSUPPORTED>

For KL based systems with KLAD20, (TOPS20 Release 4.0), IBMCON.MEM can be found in:

PS:<DN64-DOCUMENTATION>

and IBMCON.EXE can be found in:

PS:<DN64-BINARIES>

SYSERR V14(1270) AND YOUR 2020

BY: SEAN KEENAN
QUALIFICATION GROUP
MARL. SOFTWARE MAINT. ENG.

A problem was found with SYSERR after final packaging for Release 4 of TOPS20. This problem applies to the 2020 system only. In the summary listing for the disk/tape controllers a CONI RH20 is given instead of a CONI RH11.

To correct this problem a one word patch is necessary to SYSERS.EXE.

AT SL111K+2: is CAIN 1,13
 should be CAIN 1,3

Use DDT to change the file and then resave the corrected version.

SOME USEFUL INFORMATION WHEN YOU ARE LOOKING FOR DISK AND TAPE
BEHAVIOR IN A TOPS20 CRASH DUMP

BY: ALI BAKHTIARI
LSG PRODUCT SUPPORT - MARLBORO

By looking at figure 1 (page 13), and the following description you should be able to find out disk and tape status in a TOPS20 crash.

1. CHNTAB is an eight-location table indexed by channel number which each location points to a CDB table. If any location contains 0 it means you don't have that RH.

CHNTAB/ pointer to CDB block for RH #0
CHNTAB+1/ pointer to CDB block for RH #1

2. CDB or channel data block has all information about RH and channel.

Note that the pointer in the CHNTAB location points to a location in CDB table which is called CDBSTS.

Bits 31-35 of CDBSTS contain TYPE FIELD which will be interpreted as follows:

TYPE FIELD

1	=	RH10
2	=	RH20
3	=	RH11

In this table you can find out channel status words and also CONO, CONI, DATAO, DATAI, RH, CCWS, and a lot more information.

Starting at offset CDBUDB from the location pointed to by CHNTAB (CDBSTS) pointer, you will see pointers indexed by unit number to either KDB (controller data block) or UDB (unit data block).

CONT. NEXT 4 PAGES →

3. KDB or controller data block only exists when you are dealing with the tape drive.

THERE IS NO KDB FOR DISK DRIVES

In offset KDBDDP from KDBSTS location you can see:

MASSBUS ADR OF TM02
CURRENT UDB ADDRESS
CONI RH
DATAI RH CONTROL REG.
DATAI RH DATA REG.
DRIVE CONTROL REG.
STATUS REG.
ERROR REG.
MAINTENANCE REG.
ATTENTION SUMMARY REG.
FRAME COUNTER REG.
DRIVE TYPE REG.
CHECK CHARACTER REG.
SERIAL NO. REG.
TAPE CONTROL REG.

The pointer in the CDB points to location KDBSTS (in case of the existence of a KDB) or to UDBSTS.

Bits 31 - 35 of KDBSTS and UDBSTS are type field and they will be interpreted as follows:

TYPE FIELD

1	= RP04
2	= RS04
3	= TU45
4	= TM02
5	= RP05
6	= RP06
7	= RP07
10	= RP08
11	= RM03
12	= TM03
13	= TU77
14	= TM78
15	= TU78
16	= DX20
17	= TU70
20	= TU71
21	= TU72
22	= TU7X
24	= RP20

Starting at offset KDBUDB from location pointed to by CDB (KDBSTS), you will see the pointers to UDB table indexed by unit number.

THIS IS ONLY FOR TAPE DRIVES

For disk drives, UDB pointers are in the CDB table.

4. UDB or unit data block.

The pointers in the CDB (in case of disk), or in the KDB (in case of tape) points to location UDBSTS of this table.

Bits 31-35 of location UDBSTS is type field which will be interpreted the same way as the type field in location KDBSTS.

Starting at OFFSET UDBDDP from location UDBSTS depending upon tape or disk, you will see the following information:

A. In case of tape drive:

Error Position
Error Byte Pointer
Error Byte Counter
Tape Cleaner Flag

B. In case of disk drives:

CONI RH
DATAI RH Control Reg.
DATAI RH Data Reg.
No. of Cylinders Per Unit
No. of Sectors Per Unit
No. of Sectors Per Cylinder
No. of Sectors Per Surface
No. of USEC Per LA Reg. Unit
SSF 64 (LA Reg. Unit)
Start of Last Page on Cylinder
Drive Control Reg.
Drive Status Reg.
Drive Error Reg.
Drive Maintenance Reg.
Drive Attention Summary Reg.
Drive Desired Address Reg.
Drive Drive Type Reg.
Drive Look Ahead Reg.
Drive Serial No. Reg.
Drive Offset Reg.
Drive Desired Cylinder Reg.
Drive Current Address Reg.
Drive Error Reg. #2
Drive Error Reg. #3

There is one important point:

When we get the pointer from the CDB table we don't know if it will point to a KDB or to a UDB.

Bits 29 and 30 in each status word are called BLOCK TYPE, interpreted as follows:

BLOCK TYPE

1	=	CDB
2	=	KDB
3	=	UDB

Get the pointer from CDB and go to the other table. Look at bits 29 and 30 of the first location in the table. If it is a two (2), it means this is a KDB table; if it is a three (3), it means this is a UDB table.

NOTE: ALL THE TABLES ARE DEFINED IN MONITOR MODULES PHYPAR, PHYM2, PHYP4.

FIGURE I

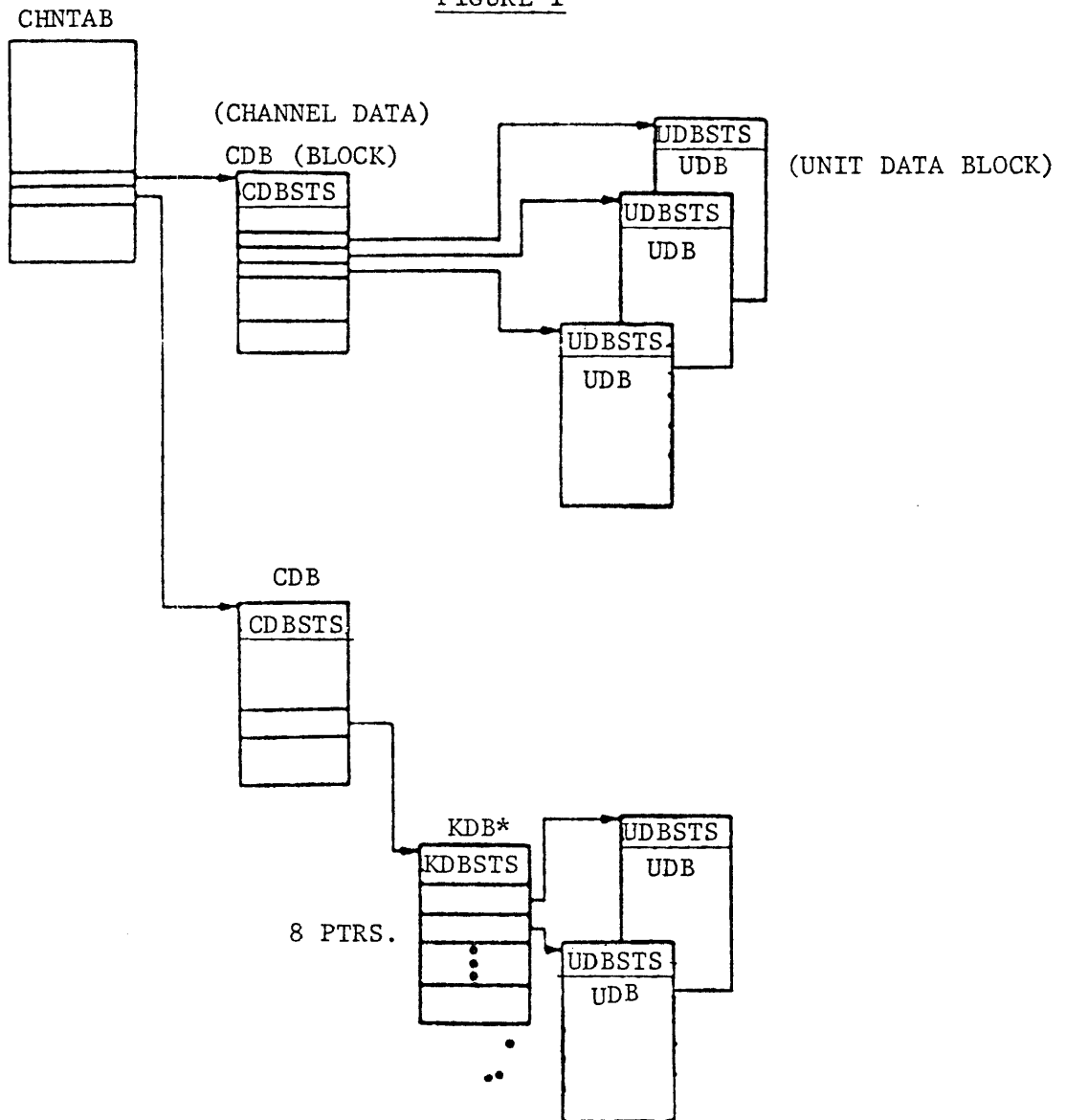

STUFF

COMPANY CONFIDENTIAL

This document contains sensitive information which shall not be disclosed to personnel outside of Digital Equipment Corporation.

This Newsletter is meant as an information document. Its contents are not necessarily Company Policy. It is a means by which LSG Maintainability Engineering can distribute some tidbits of information to you.

KLAD20 RELEASE 4 IS CURRENTLY AVAILABLE FROM THE S.D.C.

IN THIS ISSUE...

● DIAGNOSTICS

●●LATEST DIAGNOSTIC RELEASE Page 4

● HARDWARE

●●ERRONEOUS CLOCK SOURCE/CLOCK RATE AFTER POWER UP.Page 5
●●CORRECTION - REV. 3 M8616 CONSOLE BOARD SWITCH SETTINGS .Page 6
●●HOW TO READ THE LIGHTS OF EXTERNAL MEMORY 4-WAY
INTERLEAVEDPage 7
●●PROBLEM ON 1090 INSTALLATIONSPage 8
●●MF20 RTO CABLE PROBLEM.Page 8

● KLAD

●●KLAD PACK INFORMATIONPage 9

● RED PACK

●●RED PACK VERSION 404.Page 13
●●KS10 RED PACK ORDERING PROCEDURE.Page 16

● SOFTWARE

●●MORE ON KEEP ALIVE CEASED CRASHESPage 17
●●CURRENT RSX20F VERSIONS FOR TOPS10 AND TOPS20 FRONT ENDS. Page 17
●●MONITOR CRASHES RELATED TO TGHA PATCHPage 18

● SUPPLEMENTS:

●●GOOD STUFF INDEX
●●TGHA

ANY FIELD SERVICE EMPLOYEE (700 COST CENTERS ONLY) WISHING TO BE ADDED/DELETED TO THE GOOD STUFF DISTRIBUTION LIST MUST SUBMIT A MEMO OR TWX TO:

NANCIE MITCHELL
MR1-1/S35
DTN: 231-5148
TWX CODE: MR11

WITH THE FOLLOWING INFORMATION:

- YOUR NAME
- BADGE #
- COST CENTER
- LOCATION CODE
- ADDED DELETED

ALSO, SEND ANY ARTICLES WHICH YOU FEEL SHOULD APPEAR IN GOOD STUFF TO:

GOOD STUFF EDITORIAL OFFICE
c/o NANCIE MITCHELL
MR1-1/S35
DTN: 231-5148
TWX CODE: MR11

EDITOR	NIGEL WEBB
ASSOC. EDITOR	NANCIE MITCHELL
EDITORIAL OFFICE	MR1-1/S35

GOOD STUFF is published on a monthly basis.

THIS IS TO REMIND YOU THAT GOOD STUFF IS A PUBLICATION FOR DIGITAL INTERNAL USE ONLY.

UNDER NO CIRCUMSTANCES SHOULD GOOD STUFF, EXTRACTS FROM GOOD STUFF, OR COPIES THEREOF BE GIVEN OR SHOWN TO ANY INDIVIDUAL OR ORGANIZATION OUTSIDE DIGITAL.

ANY INFRACTION OF THIS RULE WILL BE BROUGHT IMMEDIATELY TO THE ATTENTION OF SENIOR MANAGEMENT WITHIN CUSTOMER SERVICES/FIELD SERVICE.

LATEST DIAGNOSTIC RELEASE

BY: DAVE ROBERT

DIAGNOSTIC ENGINEERING - MARLBORO

Release Engineering in Marlboro has just submitted new KLAD10 and KLAD20 packs for release to Manufacturing in-house.

The new diagnostic magtapes will be available to the field 12-June-80. Microfiche will also be available at that time. These tapes are called:

NAME	1600	800
DDXLAGO PERIPHERAL DIAG. MGT.	BB-E541G-DD	AP-E540G-DD
DFXLKQO KL10 CPU DIAG. MGT.	BB-E543Q-DD	AP-E542Q-DD

By reading KLAD20.UPD and KLAD20.MEM located on the KLAD20 pack in the area called <KLAD> you will find out about the changes that were made. Also, read the BEWARE.TXT file. This will tell you what new diagnostics were updated or added to the KLAD20 pack.

On the KLAD10 read the BEWARE.TXT file to find out what has changed, and also read KLAD10.MEM document.

ERRONEOUS CLOCK SOURCE/CLOCK RATE AFTER POWER UP
 MAINTAINABILITY ENGINEERING - MARLBORO

After powering up the KL10, it is possible for the clock source or clock rate to come up in the wrong state. If you should receive "? NO MASTER DTE" or other DTE related messages which seem to point to the DTE, check for the clock that is supplied to the DTE. This is the CLK 10/11 CLK H (pin F32J2). Other points to check for the 10/11 are:

MODULE	SIGNAL	1080 DTE PIN	1090 1091 2040 2050 2060 RHDTE PIN	
M8526 (YA) Clock Control	CLK 10/11 CLK H	4F32J2	4F32J2	
M8516 E&C Bus Translator	EBUS 10/11 CLK A L	4B05E1	4B05E1	
M8559 I/O Clock Distribution	CDS2 EBUS 10/11 CLK 08 L	2E02V2	2E12V2	DTE0
	CDS2 EBUS 10/11 CLK 09 L	***	2E12U2	DTE1
	CDS2 EBUS 10/11 CLK 10 L	***	2E12M2	DTE2
	CDS2 EBUS 10/11 CLK 11 L	***	2E12L2	DTE3
M8553 DTE20 Control Logic	-CDS2 EBUS 10/11 CLK 08 H	2A04F2	2A02F2	DTE0
	-CDS2 EBUS 10/11 CLK 09 H	***	2A04F2	DTE1
	-CDS2 EBUS 10/11 CLK 10 H	***	2A07F2	DTE2
	-CDS2 EBUS 10/11 CLK 11 H	***	2A09F2	DTE3

*** NOTE: 1080 SYSTEMS WILL ONLY SUPPORT ONE DTE

To check current clock under RSX20F, you must be in Programmer or Maintenance Mode and issue the "WHAT CLOCK" command.

CORRECTION*****CORRECTION*****CORRECTION
REVISION 3 M8616 CONSOLE BOARD SWITCH SETTINGS

BY: PAUL BRODEUR
 LSG PRODUCT SUPPORT - MAYNARD

This information was originally published in Good Stuff Issue No. 26 - Page 7. Unfortunately, there were a few errors--please be aware of the following corrections:

On the original switch setting chart it showed the console terminal set at 9600 baud for the factory setting. THIS WAS WRONG. Both the console and klinik should be set at 300 baud. The matrix boxes for the switch settings were correct. Just the comments stating which switches should be "ON" is incorrect. The correct setting for 300 baud console and klinik is:

E10 2,4 ON
 E173 3,7 ON

All other switches are "OFF".

NOTE: Corrected switch setting chart is below:

CONSOLE TERMINAL							
CSL2	BAUD RATE	E10 #3	E10 #4	E10 #5	E10 #6	E173 #2	E173 #3
	110	OFF	OFF	OFF	OFF	OFF	OFF
	150	ON	OFF	OFF	OFF	OFF	ON
	300	OFF	ON	OFF	OFF	OFF	ON
	600	OFF	OFF	OFF	ON	OFF	ON
	1200	OFF	OFF	ON	OFF	OFF	ON
	1800	ON	OFF	ON	OFF	OFF	ON
	2400	ON	ON	OFF	OFF	OFF	ON
	4800	OFF	ON	ON	OFF	OFF	ON
	9600	ON	ON	ON	OFF	OFF	ON

REMOTE DIAGNOSIS							
CSL9	BAUD RATE	E10 #1	E10 #2	E10 #7	E10 #8	E173 #4	E173 #7
	110	OFF	OFF	OFF	OFF	OFF	OFF
	150	ON	OFF	OFF	OFF	OFF	ON
	300	OFF	ON	OFF	OFF	OFF	ON
	600	OFF	OFF	OFF	ON	OFF	ON
	1200	OFF	OFF	ON	OFF	OFF	ON
	1800	ON	OFF	ON	OFF	OFF	ON
	2400	ON	ON	OFF	OFF	OFF	ON
	4800	OFF	ON	ON	OFF	OFF	ON
	9600	ON	ON	ON	OFF	OFF	ON

E10 2,4 ON
 E173 3,7 ON

HOW TO READ THE LIGHTS OF EXTERNAL MEMORY 4-WAY INTERLEAVED

BY: SCOTT SITTERLY
AMSTELVEEN, HOLLAND

The following will explain how to determine the physical location of a word in external memory that is 4-way interleaved by reading the lights and switches.

An example of when this is needed is if you are trying to dump core after a crash, but boots keeps giving you a I? (output error) because he is getting a memory parity error when he is reading a specific location out of core. What you need to do, to be able to get the dump is to write down all the lights in the memory that are reflecting the memory parity error. Then deposit that data back into the same location, but with good parity. You need to use KLDCP to deposit instead of parser because parser first does a read of the location before it will do a deposit and of course it gets an error when it tries to read the location with a memory parity error.

The following is an example of reading the lights and switches of two MH10's 4-way interleaved. In this example, looking at the memory box that is reflecting a memory parity error, switch 17 is equal to a one. The bank that failed was bank 2 or a binary 10 for bits 18 and 19 and the controller that failed was controller one or bit 20 equal to a one. Looking at the address lights they are equal to 03355 which shows bits 33, 34, and 35, equal to a binary 101.

17	18	19	20	33	34	35
1	1	0	1	1	0	1

Now swap bit 17 with 34, and then bit 20 with bit 35, and you get the following:

17	18	19	20	33	34	35
0	1	0	1	1	1	1

If you put these bits along with the other bits 21 through 32 from the address lights, you will get the address of 503357 and for this example this is the address you have to deposit into with KLDCP.

If you have two MG10's then you will be swapping bit 18 with 34, and then bit 21 with 35.

PROBLEM ON 1090 INSTALLATIONS

BY: DAVE BUDZIANOWSKI
WESTERN REGIONAL SUPPORT

On a number of occasions a great deal of time has been lost during 1090 system installations. This has been due to the MG10/MH10 not having the data warning jumpers wired in the MG10/MH10 backplane. Without them, when you read something out of the memory via the KL10 it is possible to get either zeros or garbage.

The jumper points are ground to the following points:

PORT 0	L39U2	PORT 4	L37U2
PORT 1	L32U2	PORT 5	L30U2
PORT 2	L38U2	PORT 6	L36U2
PORT 3	L31U2	PORT 7	L29U2

Without these jumpers in, Data Warning cannot be adjusted properly.

MF20 RTO CABLE PROBLEM

BY: DOUG DICKERSON
DDC/LCG - COLORADO

Recently, a number of intermittent MF20 problems have been caused by a bad connection of the RTO cable into the MOS power supply from the 1140 cabinet. The symptoms are that you suffer any of a number of bughalts and upon reload, the system can't see the MOS array. If you use MEMCON to look at the memory (i.e.: do a DP cmd.) it will report the controller but will not see that array either. The LED on the MF20 backplane will be out. If you run the diagnostics (DHKBF, DHKBG) the MOS may reconfigure and be reported by DHKBG and the LED turn on. This is because the LED, which indicates an "AC LOW" condition, is controlled by software. The problem is in the connector, J1, on the power supply. A little careful tightening with a pair of needlenose usually cures the problem.

You can tell the difference between this and a real power supply problem by looking at the output of the MOS supply. If the voltages look okay, then wiggle the cable. If the LED starts blinking or comes on, grab your pliers and fix the connector.

KLAD PACK INFORMATION

BY: GENE YONCHAK
M.E.G. - MARLBORO

REPRINT ***** (PLEASE READ) ***** REPRINT

As a result of Product Support requests, all KLAD systems are now under the control of L.C. Rev. and have part numbers assigned to each type of KLAD (KLAD10 or KLAD20) pack.

In addition to the KLAD-PACK, there have been part numbers assigned to KLAD "update kits". These kits are designed to allow the Field to order scheduled updates to existing KLAD systems. There is a specific ordering procedure that must be followed when ordering a KLAD-PACK, or an update kit. The cost for all material will be charged to the Field Service Branch ordering the KLAD material.

We are considering an automatic distribution method for KLAD update. Anyone wishing to be on the distribution list must send a memo to:

GENE YONCHAK
200 FOREST STREET
MARLBORO, MA 01752
MR1-1/S35

with the following information:

1. Digital Office
2. Digital Address
3. Location Code - Mail Stop
4. Phone Number/Ext.
5. Cost Center
6. Engineer's Name
7. Badge #
8. Supervisor's Name
9. Indicate;
KLAD10 or KLAD20

NOTE: All material will be mailed to your Digital Office, c/o your Supervisor. Costs for the material will be JV'd to individual Cost Centers.

CONT. NEXT 3 PAGES →

NON-COMPLIANCE OF THESE PROCEDURES WILL RESULT IN A NO-FILL OF YOUR ORDER.

A. Part Numbers - KLAD10 and KLAD20

1. KLAD10 RP04 Disk Pack - ZH101 PK

Contains: One (1) RP04 disk pack, and one (1) diagnostic magtape. Unless specifically directed, the content material will be the latest version.

2. KLAD10 RP06 Disk Pack - ZH102 PL

Contains: One (1) RP06 disk pack, and one (1) diagnostic magtape. Unless specifically directed, content material will be the latest version.

3. KLAD20 RP04 Disk Pack - ZT101 PK

Contains: One (1) RP04 disk pack, and one (1) diagnostic magtape. Unless specifically directed, content material will be the latest version.

4. KLAD20 RP06 Disk Pack - ZT102 PL

Contains: One (1) RP06 disk pack, and one (1) diagnostic magtape. Unless specifically directed, content material will be the latest version.

5. KLAD10 Update Kit - ZH100

Contains: Front-end Dec Tapes (3), KLAD10 "BACKUP" format magtapes, and a "how to do it" build document.

6. KLAD20 Update Kit - ZT100

Contains: System floppies (A,B, and C), three (3) "dumper" format magtapes, and a "how to do it" build document.

B. Ordering Procedure (Other than Automatic Distribution)

Now that part numbers have been assigned to KLAD packs, it was necessary to institute an ordering procedure to prevent this diagnostic tool from being ordered without proper authorization. For this reason, we have chosen to utilize the DEC "I.O.F." (Internal Order Form). This form must be filled out (as illustrated by attached example) by the person requesting the KLAD material; must have a shipping address; must have the signature and badge # of the individuals' Branch or Unit Manager; and be forwarded directly to LSG F.S. Product Support for approval. This form will be given to S.D.C. where it will be filled and sent to the Field Service Branch Manager of the individual requesting the KLAD material.

NOTE: S.D.C. has been instructed to ship only to bona-fide DEC offices. They will not ship KLAD material to a customer site. There are contingency plans to allow for the delivery of KLAD material to those places where the "bona-fide DEC office" happens to be in an individuals' home.

The S.D.C. will provide a 24-hour turn around time for all field requests, provided that the I.O.F. be received by LSG F.S. Product Support in Maynard (PK3-2/K11), by 11:00 hours, Monday through Friday.

In the event of a major catastrophe, and the delay caused by the I.O.F. is unacceptable, there is a procedure whereby a Branch or Unit Manager may telephone his request to LCG F.S. Product Support (DTN: 223-7353). He must supply all the information normally supplied on the I.O.F., and LSG F.S. Product Support will authorize a verbal approval to ship the requested KLAD pack. This procedure will be available only for the emergency replacement of a KLAD10 or KLAD20 disk pack, and not KLAD update kits!

After completing his telephone request for KLAD material, the Branch, or Unit Manager, must complete the I.O.F. and submit it to LSG F.S. Product Support in Maynard, with the notation:

"EMERGENCY TELEPHONE REQUEST FILLED ON: DD-MM-YY"

in the box "special instructions."

EXAMPLE KLAD PACK ORDER



INTERNAL ORDER FORM

PAC CODE	AG CENTER	OFC NO
----------	-----------	--------

NEGOTIATED BY JAY RANDOM	BADGE # 123456	LOCATION MRI-1/S35	EXT 0000	DATE 12-UN-80	RESP PROD LINE F.S.
-----------------------------	-------------------	-----------------------	-------------	------------------	------------------------

USE: IN-HOUSE DEMO TRADE-SHOW P/L ROTATION CAPITAL EQUIPMENT

DELIVER TO:		LINE VOLTAGE N/A	LINE FREQ N/A	REQ DEL DATE ASAP	SCH DEL DATE
NAME MR. FIELD SERVICE MANAGER - c/o DIGITAL EQUIP.	ADDRESS 123 DIGITAL BLVD.	EQUIP TO BE RETURNED*		COST CTR XXX	ASAP
OR DLC CITY, USA ZIPCODE	D E C LOC	TYPE ORDER SYSTEM	MODEL NO KL10	TO BE CAPITALIZED?	
CUST CODE	NA NO	ADD-ON SPARE	SERIAL NO 2345	<input type="checkbox"/> YES <input checked="" type="checkbox"/> NO	

REASON FOR REQUEST: KLAD PACK UPDATE XSS 2130

SPECIAL INSTRUCTIONS:
FORWARD DIRECTLY TO LSC FIELD SERVICE PRODUCT SUPPORT - PK3-2/K11 FOR APPROVAL - ATTENTION: PRODUCT SUPPORT SUPERVISOR

ITEM	QTY	MODEL NO.	DESCRIPTION	P.L. CODE	PART ALOR	STANDARD UNIT PRICE	AMOUNT
1.	1	KLAD10	ZH101 PK KLAD SYSTEM (RP04)	--	--		
2.	1	KLAD10	ZH102 PL KLAD SYSTEM (RP06)	--	--		
3.	1	KLAD20	ZT101 PK KLAD SYSTEM (RP04)	--	--		
4.	1	KLAD20	ZT102 PL KLAD SYSTEM (RP06)	--	--		
5.	1	KLAD10	ZH100 KLAD UPDATE KIT	--	--		
6.	1	KLAD20	ZT100 KLAD UPDATE KIT	--	--		
TOTAL							

COST CENTER MANAGER	DATE	P.L. MANAGER FURNISHING EQUIPMENT	DATE
FINANCE	DATE	SCHEDULING RESTRICTION	
TO BE COMPLETED BY S.D.C.			

1. COMPUTER ADMINISTRATION 2. FINANCE 3. PRODUCT LINE 4. ORIGINATOR
 COMPUTER ADMINISTRATION

RED PACK VERSION 404 - PATCH #1

ORIGINATED BY: Maintainability Engineering - Marlboro

PROBLEM: When obtaining a Syserr Summary, a CONI RH20 is given instead of a CONI RH11.

PREREQUISITE: RED PACK VERSION 404.

SOLUTION: Install this patch.

HOW TO INSTALL:

```
LOG F-S F-S           ;LOG IN AS F-S
ENA                   ;ENABLE CAPABILITIES
CONN <SUBSYS>         ;CONNECT TO SUBSYS
GET SYSERS.EXE       ;GET THE PROGRAM TO PATCH
DDT                   ;RUN DDT
SL111K+2/ CAIN 1,3   ;AT SL111K+2 PUT CAIN 1,3
^Z                    ;DO A CONTROL Z
SAVE SYSERS.EXE      ;SAVE THE PATCHED PROGRAM
CONN                  ;CONNECT BACK TO <F-S>
LOGO                  ;AND LOG OUT
```

RED PACK VERSION 404 - PATCH #2

ORIGINATED BY: Maintainability Engineering - Marlboro

PROBLEM: When running 2020 UETP acceptance, the magtape tests time out by exceeding the batch time limit.

PREREQUISITE: A 2020 System with less than 512K of MOS memory and Red Pack Version 404.

SOLUTION: Install this patch which increases the batch time limit for UETP.

HOW TO INSTALL:

```
$=ALTMODE
@LOG F-S F-S
@ENA
$TV PS:<SUBSYS>SYSTEM.CMD
*S6$-D$I9$$
*S6$-D$I9$$
*S6$-D$I9$$
*S6$-D$I9$$
*HT$$
*;U$$
OUTPUT FILE: PS:<SUBSYS>SYSTEM.CMD.1
*;Y$$
INPUT FILE: PS:<UETP.LIB>RELIAB.CMD
*S1:$2D$I30$$
*HT$$
*;X$$
OUTPUT FILE: PS:<UETP.LIB>RELIAB.CMD.1
$LOGO
```

Bring the system down then back up to run UETP.

KS10 RED PACK ORDERING PROCEDURE

BY: PETE MARTI
M.E.G. - MARLBORO

To order the tapes needed to build a Red Pack, enter both descriptions and part numbers on an Internal Order Form (IOF) that are listed below. They may be ordered separately if so desired via the same form.

The IOF is subject to the approval of LSG Product Support.

<u>DESCRIPTION</u>	<u>PART NUMBER</u>
RED TAPE #1	BB-H214C-RM
RED TAPE #3	BB-H216C-RM

EXAMPLE RED PACK ORDER

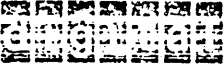
		INTERNAL ORDER FORM		FORM CODE	FORM CENTER	FORM NO.	
REQUESTED BY JAY RANDOM	BADGE # 123456	LOCATION MR1-1/S35	EXT 0000	DATE 12-JUN-80	RESP PROD LINE F.S.		
USE: <input type="checkbox"/> IN-HOUSE <input type="checkbox"/> DEMO <input type="checkbox"/> TRADE-SHOW <input type="checkbox"/> P/L ROTATION <input type="checkbox"/> CAPITAL EQUIPMENT							
DELIVER TO: NAME MR. FIELD SERVICE MANAGER - c/o DIGITAL EQUIP. ADDRESS 123 DIGITAL BLVD. OR DEC CITY, USA ZIPCODE D/E C LOC. CUST CODE RA NO			LINE VOLTAGE N/A	LINE FREQ N/A	REQ DEL DATE ASAP	SCH DEL DATE	
			EQUIP TO BE RETURNED? YES. WHEN? X NO XXX		COST CTR. ASAP		
			TYPE ORDER SYSTEM ADD-ON SPARE	MODEL NO KL10 SERIAL NO 2345	TO BE CAPITALIZED? YES X NO		
REASON FOR REQUEST <u>TAPES NEEDED TO REBUILD A RED PACK</u>			X95	2160-			
SPECIAL INSTRUCTIONS FORWARD DIRECTLY TO LSG FIELD SERVICE PRODUCT SUPPORT - PK3-2/K11 FOR APPROVAL - ATTENTION: PRODUCT SUPPORT SUPERVISOR							
ITEM	QTY	MODEL NO	DESCRIPTION	P/L CONF	PART ALLOW	STANDARD UNIT PRICE	AMOUNT
1.	1	BB-H214C-RM	RED TAPE #1	--	--		
2.	1	BB-H216C-RM	RED TAPE #3	--	--		

MORE ON KEEP ALIVE CEASED CRASHES

BY: CLIFF ROMASH
NER TECHNICAL SUPPORT

Hopefully, many of you have been helped by my earlier article on Keep Alive Ceased Crashes (Good Stuff #24). Some additional information has come to light.

First, on a TOPS20 system (before Release 4), the procedure for taking a dump should be changed. After collecting the PC's, do an XCT 256000000071. This is a XCT 71, which will cause a KPALVH Bught, with all information saved. This step should then be followed by entering KLI and taking a dump. Note that this is the best procedure to follow anytime you want a complete software dump of a TOPS20 system.

Second, in TOPS20 Release 4, and TOPS10 V700 (and on all 2020 systems), you should no longer see KEEP ALIVE CEASED crashes or have to worry about how to dump them. On TOPS20, the Bught KPALVH replaces Keep Alive Ceased; on TOPS10 it is the stopcode KAF. The dump procedure should be the same as on any other Bught/stopcode.

CURRENT RSX20F VERSIONS FOR
TOPS10 AND TOPS20 FRONT ENDS

BY: LARRY MIDURA
M.E.G. - MARLBORO

<u>RSX20F VERSION</u>	<u>TOPS20</u>
12(34) 13(41)	Rel. 3A Rel. 4
<u>RSX20F VERSION</u>	<u>TOPS10</u>
12(40) 14(17)	6.03A 7.01

NOTE:

7.01 is scheduled for Release in September 1980. The version shown for 7.01 is the version being shipped to field test sites currently.

MONITOR CRASHES RELATED TO TGHA PATCH

BY: SCOTT HEMPHILL
MR1-2/S43

Some customers have reported having problems after installing the required monitor patch for TGHA support. The symptoms were a variety of paging BUGHLTs including ILPAG1, SECGT1, and possibly others. It has been discovered that the problems were caused by either the customer or a specialist editing the control file with EDIT, which replaced some bare linefeeds in the control file with carriage-return linefeed pairs. In any case, the presence of tabs and bare linefeeds within the control file TGHA-PATCH-3A.CTL makes it more difficult to figure out what the patch is doing. It is suggested that the software specialist not edit this control file, but place any additional commands (such as "ENABLE" or defining logical names to pick up the right monitor) in the file BATCH.CMD. Another alternative is to use the reworked control file printed below, which has no tabs or bare linefeeds. In any event, it is important to make sure that the patch gets correctly installed.

```
@ENABLE
@GET PS:<SYSTEM>MONITR.EXE
@START 140
*PMCRM2/LDB T1,FFF
*FFF/44002,,0
*FFF+1/FFF:
*UNWEPT+2/JRST FFF
*FFF/CONO TIM,60144
*FFF+1/CONO MTR,412003
*FFF+2/JRST MTRON
*FFF+3/FFF:
=^Z
@SAVE PS:<SYSTEM>MONITR.EXE
```

This article originally appeared in The Large Buffer, Volume 511,
22-May-1980.

Good stuff

ISSUE NO. 32

AUGUST FY'81

COMPANY CONFIDENTIAL

This document contains sensitive information which shall not be disclosed to personnel outside of Digital Equipment Corporation.

This Newsletter is meant as an information document. Its contents are not necessarily Company Policy. It's a means by which LSG Maintainability Engineering can distribute some tidbits of information to you.

IN THIS ISSUE ...

● DIAGNOSTICS

- DFDTE FAILS IN SECONDARY FRONT ENDS Page 3

● HARDWARE

- RH20 BACKPLANE PROBLEM CAN CAUSE DISK PORTS TO LOCK UP. Page 4
- SETTING NO RELOAD ON 2020 SYSTEM. Page 6
- TM03 (M8901, DATA SYNC) Page 6
- MF20 H7131 POWER SUPPLIES (ACDC ELECTRONICS). Page 7

● MISCELLANEOUS

- EVERYTHING YOU EVER NEEDED TO KNOW ABOUT ORDERING THE
KL10/KS10 MAINTENANCE GUIDE Page 9
- PART NUMBER FOR H955 DOOR STOP. Page 11

● SOFTWARE

- 7.00 SOFTWARE PROBLEMS. Page 12
- 1091 MOS MEMORY SUPPORT Page 12

ANY FIELD SERVICE EMPLOYEE (700 COST CENTERS ONLY) WISHING TO BE ADDED/DELETED TO THE GOOD STUFF DISTRIBUTION LIST MUST SUBMIT A MEMO OR TWX TO:

NANCIE MITCHELL
MR1-1/S35
DTN: 231-5148
TWX CODE: MR11

WITH THE FOLLOWING INFORMATION:

- YOUR NAME
- BADGE #
- COST CENTER
- LOCATION CODE
- ADDED DELETED

ALSO, SEND ANY ARTICLES WHICH YOU FEEL SHOULD APPEAR IN GOOD STUFF TO:

GOOD STUFF EDITORIAL OFFICE
c/o NANCIE MITCHELL
MR1-1/S35
DTN: 231-5148
TWX CODE: MR11

EDITOR	NIGEL WEBB
ASSOC. EDITOR	NANCIE MITCHELL
EDITORIAL OFFICE	MR1-1/S35
GOOD STUFF is published on a monthly basis.	

DFDTE FAILS IN SECONDARY FRONT ENDS

BY: BILL SCORZELLI
DIAGNOSTIC ENGINEERING - MARLBORO

DFDTE Version 0.10 fails in the following way when MOS memory is used with the front ends:

SYMPTOMS:

DECSYSTEM KL10 DTE20 FUNCTIONAL DIAGNOSTIC (DFDTE) VERSION 0.10,
SV=0.1, CPU#=2136, MCV=157, MCO=1, HO=36, 60HZ
SWITCHES = 400000 000000
CLK SOURCE = NORMAL, CLK RATE = FULL, AC BLK 0, CACHE: 0 1 2 3
MEMORY MAP = FROM TO SIZE/K 00000000 00777777
256
TESTING DTE20 #1
PC = 037417 SWITCHES = 400000 000000 ERROR IN TO11 BYTE XFER
ERROR TERMINATION NO TO11 ERR TERM ACTUAL: 000100 UNIBUS
TIMEOUT

PC = 037426
ERROR IN TO11 BYTE XFER ERROR TERMINATION - INCORRECT 11 STATUS
CORRECT: 004002
ACTUAL: 004200
DISCREP: 000202
UNIBUS TIMEOUT

PC = 037445
SWITCHES = 400000 000000
ERROR IN TO11 BYTE XFER TERMINATION - PDP-11 TO11AD ERROR
CORRECT: 003000
ACTUAL: 003002
DISCREP: 000002
UNIBUS TIMEOUT
END PASS 1.

SOLUTION:

Version 0.13 of DFDTE (soon to be released) will fix this problem.

RH20 BACKPLANE PROBLEM CAN CAUSE DISK PORTS TO LOCK UP

BY: JERRY GANNELLI

LSG INSTALLATION QUALITY - MARLBORO

LSG Manufacturing Engineering has uncovered a problem which can cause the disk ports to lock up. The problem is caused by a faulty etch in the signal path from the backplane pin.

PROBLEM DESCRIPTION:

The etch running J32A2 to C30 of RH20 MBUS 0 connector and L32E2 to C30 of RH20 MBUS 1 connector on the I/O backplane (70-09429) measures from 25-96 ohms of resistance. This keeps MBUS 0 and MBUS 1 TRA L signal from obtaining a true low level.

REWORK INSTRUCTIONS:

The diagram on the following page shows the location of the two backplane pins which need rework. The pin is marked point A on the exploded view. This pin must be soldered to the pad on both RH20 MBUS 0 and RH20 MBUS 1.

PROBLEM FIX:

1. Inspect the two solder points (see rework instructions above).
2. Using a DVM, verify a zero ohms condition exists between the following points:

J32A2 to C30 of RH20 MBUS 0
L32E2 to C30 of RH20 MBUS 1

3. After the above check/correction has been completed, please identify the fact with an adhesive label near the connections and also make a note in the Site Management Guide.

NOTE: Cross Reference RH20-TT-6

CONT. NEXT PAGE →

DIAGRAM

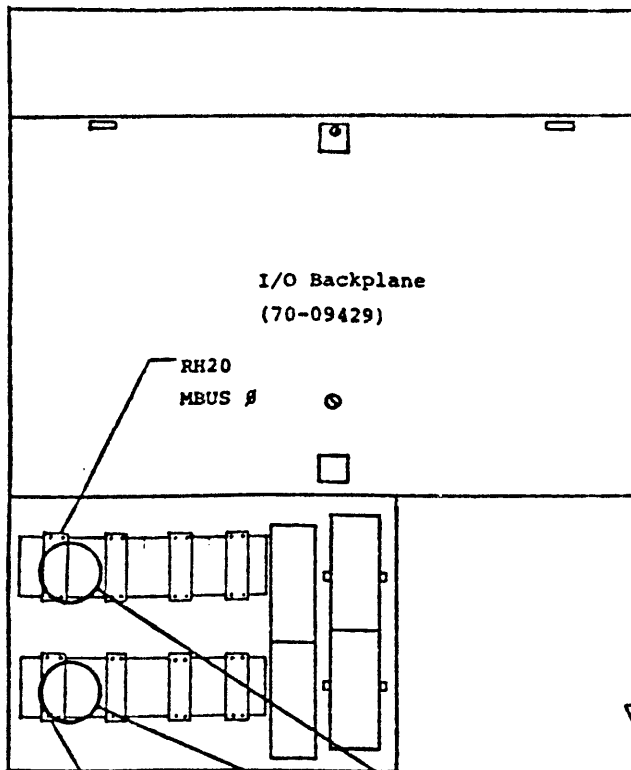

PLACE LABEL HERE

CHECK/CORRECTION
COMPLETE / /

RH20
MBUS 1

Point A

MF20 H7131 POWER SUPPLIES (ACDC ELECTRONICS)

BY: GENE YONCHAK
M.E.G. - MARLBORO

According to feedback from the Field, there has been a discrepancy about the wiring of the H7131 AC/DC power supplies margin sense-harness on an MF20.

Several major ECO's are in progress to "clean-up" existing errors in the print set. Until new prints are available, use the following charts when installing a replacement power supply.

Cross Reference: MF20-TT-1

MF20 LA/LBHARNES CONNECTION CHART #9

ITEM NO	HARNES TERM		CONNECTION
	POINT	CONNECTION	
69		J1	MF20 #1/PA01
↑	8		H7131 #1/TB6-3
	7		H7131 #1/TB6-4
	6		H7131 #1/TB5-4
	5		H7131 #1/TB5-3
	4		H7131 #1/TB4-4
	3		H7131 #1/TB4-3
	2		H7131 #1/TB3-3
↓	1		H7131 #1/TB3-4
69		P1	H7131 #1/J1

CONT. NEXT PAGE →

MF20 (017131) SENSE HARNESS CONNECTIONS
(ACDC ELECTRONICS)

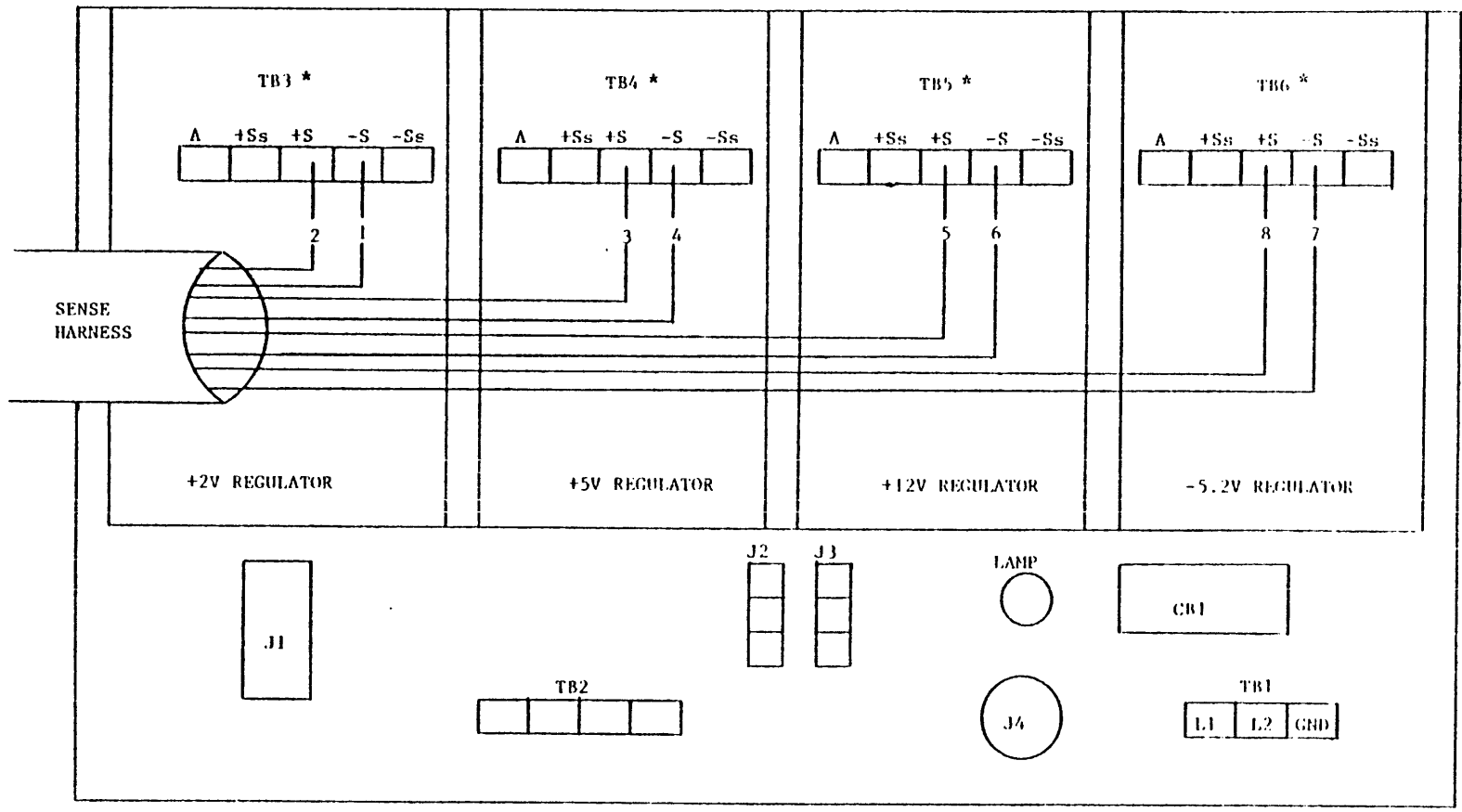

* TERMINAL NUMBERING
(TB3-TB6)

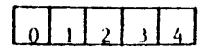

EVERYTHING YOU EVER NEEDED TO KNOW ABOUT ORDERING
THE KL10/KS10 MAINTENANCE GUIDE

BY: LOU NAY
M.E.G. - MARLBORO

Do you subscribe to Playboy/Playgirl? If you do, then you know how the distribution of the KL10 and KS10 Maintenance Guides should work.

I have broken the ordering procedures down into four sections. PLEASE only follow the instructions which pertain to you.

KL10/KS10 ORDERING PROCEDURES

1. Ordering Procedures if you never received a KL/KS Maintenance Guide

If you have never been on the distribution list, and you want to obtain a copy of one of the guides, order by TWX or memo to:

CIRCULATION SERVICES
NR2-2/C4

specifying the following information:

1. Your Name
2. Badge Number
3. Cost Center
4. Location
5. Quantity: 1*
6. EK-OKL10-MG (KL10 Maintenance Guide)
or
EK-OKS10-MG (KS10 Maintenance Guide)

* ORDER ONLY ONE COPY PER NAME.

CONT. NEXT 1½ PAGES →

2. Ordering Procedure for KL10 Maintenance Guide updates only.

If you have a copy of the KL10 Maintenance Guide and did not receive updates 1 through 5 (distributed June 1980), then your name is quite possibly not on the distribution list. To correct this situation, send a TWX or memo to:

CIRCULATION SERVICES
NR2-2/C4

specifying the following information:

PLEASE ADD MY NAME TO THE DISTRIBUTION LIST

1. Name
2. Badge Number
3. Cost Center
4. Location
5. KL10 Maintenance Guide - Updates
Order the updates you need.
 - a. Update 1 - EK-OKL10-001
 - b. Update 2 - EK-OKL10-002
 - c. Update 3 - EK-OKL10-003
 - d. Update 4 - EK-OKL10-004
 - e. Update 5 - EK-OKL10-005

3. Ordering Procedure for Volume II KS10 Maintenance Guide

If you have Volume I of the KS10 Maintenance Guide and did not receive Volume II (Software and Diagnostics) distributed June 1980, then your name is quite likely not on the distribution list for that guide. To correct this situation, send a twx or memo to:

ALLEN PRATT
NR2-2/C2

specifying the following information:

PLEASE ADD MY NAME TO THE DISTRIBUTION LIST

1. Name
2. Badge Number
3. Cost Center
4. Location
5. EK-OKS10-MG (VOLUME II ONLY)

4. To be deleted or to transfer your subscription to someone else--

Send a twx or memo to:

ALLEN PRATT
NR2-2/C2

with the following information:

REMOVE: Your Name
Badge Number
Cost Center
Location

ADD: New Name
Badge Number
Cost Center
Location

state which Maintenance Guide you want to transfer or stop receiving:

1. EK-OKL10-MG - KL10 Maintenance Guide
or
2. EK-OKS10-MG - KS10 Maintenance Guide

PART NUMBER FOR H955 DOOR STOP

BY: DICK GARANT
IHFS - HZ

I recently came across some difficulty in finding a part number for the telescoping door stop on the H955 cabinet. (MH10's, DL10, etc.).

The part number for this door stop is 12-05847 and can be found on drawing number E-UA-H955-D-0. Also found on this same drawing is the mounting bracket which is known to bend out of shape. The number for it is 74-9001.

I hope these numbers can save someone else a little time in researching.

7.00 SOFTWARE PROBLEMS

BY: CLIFF ROMASH
NER PRODUCT SUPPORT - WALTHAM

Recently, I encountered several problems which were seemingly hardware problems on a system newly running TOPS10 Version 7.00. All turned out to be software problems, so I am taking the time to document the symptoms here to hopefully save you problems. For those which indicate, a patch is available, the patch can be obtained via the software hotline in Marlboro (DTN 231-6492 or (617) 467-6492) or from a Large Buffer article which will be published shortly.

SYMPTOMS:

1. KSW and USW stopcodes - No patch yet available.
2. Hung device MTxxxx on a DX10 subsystem, with the entire subsystem hung - patch available.
3. Disk Offline - SYSERR shows logical block = -1 - three patches available.
4. System or one disk controller hung with many jobs in DI and/or PI - patch available.

NOTE: This article is applicable to both TOPS10 Version 7.00 (controlled release) and TOPS10 Version 7.01 (at field test sites).

These problems will be corrected in the final release of Version 7.01. In the interim you may experience them.

1091 MOS MEMORY SUPPORT

BY: RICK ELLISON
SOFTWARE MAINTAINABILITY ENGINEERING GROUP - MARLBORO

MOS memory on DECsystem-10's is now supported by the "TOPS10, Version 7.01 LIR for DECsystem-1091-S". This software is a controlled release of 7.01 (much like KL10 SMP in 7.00). To get the software, a controlled release plan must be signed by the Branch Sales, Software and Field Service Managers. If you know of a customer who will be receiving a 1091-S or adding MOS to an existing 1091, (between now and October 1980), please make sure the responsible Sales Representative has his or her manager contact Jack Walden, in Marlboro, (MR1-1/S35 - 617-467-5125, or DTN: 231-5125), to get a copy of the plan.

This controlled release of the software will go away when the complete 7.01 monitor is available from SDC (estimated September 1980).

BASIC PROCEDURE FOR GETTING ERROR INFORMATION ON AN INTERMITTENT KL10 OR DEC20

Assumptions - KL10 monitor 6.03 + VER. 6A RSX20F DEC20 - TOPS20 VER. 2 +
RSX20F. VER. 157 microcode

"This procedure will work on earlier versions with some modification to the loading procedure."

- I. First we must set no reload so the 11-front end will not reboot the system upon a detection of a crash. (Underlined statement you will type.)

DEC20: @ CONTROL BACKPLASH (Go to PARSER)
PAR > SET CONSOLE MAINTENANCE
PAR > SET NO RELOAD
PAR > QUIT (back to monitor)

KL10: At present; setting no reload under RSX20F alone will not keep KL10 from reloading. You must also change a monitor location as follows:

BTS > SYSTEM/L
BTS > /401
BTS > /G
(Now in EDDT)
COMMON \$:
BNXMTS +1/cono 10,0 HALT
DEBUG \$G

If the problem is intermittent a better method is as follows:

.R FILDDT
File: SYSTEM/S
File: /M/P
DEBUG/440000,,0
This will disable auto reload and will halt the system
^Z
This must be redone after each crash.

- II. When the system crashes it will halt upon the detection of an error and will not reload.

- A. On the CTY or remote KLINIK LINK: Type ^/
B. Parser will not echo one of three prompts:
= clocks stopped
> = KL10 running
% = KL10 halted
C. If parser echoes PAR> ... go to addendum for PAR> procedures.
D. If parser echoes PAR#... go to addendum for clock stop errors.
E. If parser echoes PAR% the KL10 is halted and collect data as follows:

- III. The basic procedure will be as follows, however, each error will be treated differently as we progress through information collection.

Here if KL10 Halted; PAR%

- A. Bring up and inilitize KLDCP
1. Mount KLAD
2. PAR% MCR BOO,
3. BOO % DBOOT Now in KLDCD

REC
FILE

FUNCTION
READ

B. Collect data starting from 11/40 and work toward 10.

- 1. FX0
- FR 110
- FR 160, 162
- FR 171, 172
- FR 177
- FR 100, 177

Assure clocks off

Collect all error bit.
Refer to attachment to
decode bits.
= if preferred

This will give you a basic idea of
the type of error seen.

GEN IFO
R-1-1

C. Load TRACE or TRACON and get snapshot of KL10

- 1. p Tracon
- SED

* L

*D

This will allow us to answer questions
for maximum information.
This will dump the KL10 in neumonics and
give you an indication of the failure
and what the KL10 was doing.

D. Back to KLDCP

- 1. FXI ^{PEP} ^{PARITY ENABLES} Turn clocks on
- 2. AC BLK 7 Select u-code BLK
- 3. KL10 only
 - a. EM 0 = AR Data
 - b. EM 1 = ARX Data
- 4. DEC20 only
 - a. EM 0 = Bad Data AR or ARX
- 5. DEC20 only
 - a. AC BLK 6
 - b. EM 12 = Page fail word
 - c. EM 16 = AR Data
 - d. EM 17 = ARX Data
 - e. EM 5 = VMA
- 6. KL10 + DEC20
 - a. AC BLK 7
 - b. EM 2 = IOPG Fail word

E. Collect error information

- 1. EX 700400 5 Read and collect ERA: Valid if APR interrupt
EM 5
- 2. EX 700240 6 Read and collect APR
EM 6

F. Read DTE Status

- 1. EE 774434

Dispatch to error from function reads and system type.

- V. At this point the procedure will depend on the error indication, from FR's, and system type. We will discuss each error individually.

NOTE: The following information should be used in conjunction with the KL10 handbook and the chart for errors in this text.

A.1. MB PAR ERR

- a. The MA/MB do not use RD or WR parity checking.
- b. Look at ERA determine direction of cycle and type from data SRC.
- c. IFCHAN Ref = 0; and write = 0; any data source except 1,1 (channel read from cache)...start at MA/MB and work toward MB's.
- d. Address will indicate storage module - decode with print set for amount of memory and intv.
- e. If write Ref = 1 data SRC = 1,0 start at AR work toward MB. EBOX writing to memory.
- f. For cache and channel transfers refer to sections under cache or channel.
- g. Run DDMMD, DGKBB at clock margins.

2. SBUS ERROR

- a. In the MA/MB SBUS ERR comes from an incomplete request:
- b. The ERA will be invalid, however, the base address will still be held.
- c. Use Conex and SBUS diagnostic to determine controller

P-Conex
SED
SD
Controller=X
Function Code=0
Change Inter.=N
Reset Errors=N
xxxxxxxx=data

Bit 2 will tell which controller sent the error. If no INC/cycle start at SBUS translators, M8519; and work toward controller.

- d. Run DGKBB, DGMMA at clock margins.

3. SBUS ADDRESS PARITY

- a. Read ERA - address is Latched.
- b. Use SBUS diags to determine which controller received the ERR.
- c. Start at controller work toward SBUS translators (8519); if errors occur in multiple controllers, problem may be in PMA (8518).
- d. DGKBB will isolate bit.

4. NXM's

- a. There are two types one for the M box and one for the MA/MB.
- b. M box NXM are when after the memory request no ACK comes back for 64 microsec.
- c. APR will show error bit.
- d. If ERA WD # is equal to base address then the NXM is from the M box.
- e. In this case start at controller work toward translators, to the PMA.
- f. Also, the M box control logic may be at fault.
- g. Run DGKBA.
- h. If ERA word # is not equal to the base address then the MA/MB lost one of the QUAD word requests, 8 microsec time out.
- i. Decode storage module using WD# for bits 34, 35 of base address, work back to translators.

- j. isolate with D&KBB, DGMMA - or 10/based memory diagnostic. Run clock margins.
- k. There is no NXM bit in the MA/MB memory; NXM corresponds to INC/Cycle.

B. 10XX - DMA

1. DATA PARITY ERRS or SBUS ERRS

- a. MB PAR will be latched in APR.
- b. SBUS diagnostic will show error and ADDR.
- c. Rule out memory first.
- d. Determine K-bus from S-bus diagnostic.
- e. If ERA indicates a channel write reference, refer to channel section.
- f. Start at M8558 work toward translators.
- g. Run DGKBB for DMA
Run DGMMA or 10/based memory diagnostic for MG/MH
- h. ERA may be invalid due to SBUS ERR.
- i. If no SBUS ERROR start at DMA and work toward MB.

2. SBUS ADDR Parity

- a. Checked in DMA on RD - WR
- b. ERA is VALID
- c. Determine address from ERA
- d. Decode K-Bus from WD#
- e. Start at M8558 work toward translator - remembering the address is gated through the M8560.
- f. Check de-skew
- g. Run DGKBB or address test under 10/based diagnostics.

3. NXM's

- a. Again there are two types M box - DMA
- b. Treat M box as before, however, start at DMA M8563.
- c. If word number does not equal buse address of ERA 34, 35 then NXM come from DMA. Start at M8558 or KBUS.
- d. Work toward translators.
- e. Run DGKBB - DGMMA with clock margins.
- f. Check DE-Skew.
- g. Rule out memory first.

C. CACHE FAILURES

- 1. Cache failures may be hidden by what appears to be memory problems or DMA failures.
- 2. The ERA will be the biggest help.
- 3. If write = 1 and data SRC = 1,1 start a cache and work toward MB.
- 4. A good indication of a bad cache quarter is if the last three octal digits of the failing addresses are always the same.
- 5. If a cache cycle is reported along with a SBUS ERROR and MB parity error start at MB's and work toward DMA; if KL10.
- 6. If write = 0 and data SRC = 1, 1 you are doing a chan ref. or page refill and problem can be from MB to AR to cache - start at MB's then cache if no AR/ARX parity ERR,.. if AR/ARX parity error then start at cache to AR to MB.
- 7. Cache problems can also be reflected as AR/ARX parity errors - see AR/ARX section.
- 8. Run DGMCA - DGMCB - clock margins and run DFKDA.

D. CACHE DIRECTORY PARITY ERRORS

- 1. APR will indicate error.

2. Use ERA, it may indicate sweep reference and address will show line number by last three digits octal.
3. Truly an address parity error.
4. Start at address logic M8515 work toward PMA- via the M8523 VMA board.
5. The M8514 comes into play by holding the actual cache directory information.

E. PAGE TABLE PARITY OR PAGE REFILL ERROR

1. First we can collect the page fail word via KLDCP.
EX 701040 5 Data: Page = UBR
EM 5 Data: Right half is UBR refer
 KLHB page (37)
2. UBR + 500 = Page fail word.
3. Refer KLHB Page (33)
4. Right half = address.
5. Use left half to decode page fail code.
6. If page table parity start at hardware pager M8520 work toward MB's.
7. If Page refill and SBUS error go back to DMA to MG or MA/MB to translators.
8. The M8513 controls much of the refill logic.
9. If Page fail code equals 36 or 37; go to AR/ARX section.
10. Note: MB PAR will be set in conjunction with Page table errors.
11. Run DFKDA clock margins, run DFKEA clock margins.

F. AR/ARX PARITY ERRORS

1. Page fail code of 36 or 37 occurs.
2. Collect page fail word as in Page Table Parity section and data from snapshot of AC Blocks.
3. Note: MB parity ERR may or may not be set. The AR/ARX is a final catch all for errors not detected elsewhere. Caution should be taken as these errors may be misleading, however, if close detail is noted when looking at the ERA it will simplify matters greatly. APR must be latched with a subsequent error to use ERA.
4. If ERA data SRC = 0, 0 + write = 0, then go back to MA/MB to MB's or DMA to MB's.
5. If no MB PAR then start at MB, work toward AR/ARX.
6. If cache present; a problem can be from AR to cache, or cache to MB, or MB to AR/ARX but only on a data SRC of read. Otherwise sweep would be set.
7. Run the system exerciser, 20 = DFSXA; 10 = DFSXA-C clock margin.
8. AR or ARX errors always cause a page trap to ucode 1777. They may also generate a MB PAR ERROR to do a core sweep. (i.e. version 2 TOPS20)

G. CHANNEL ERRORS

1. Channel errors can be quite misleading, but again, noting the ERA will simplify matters.
2. Function reads 162 - 171 - 172 will give errors.
3. Note: All channel errors will not result in an APR interrupt until they are detected coming out of the MB's, or back as address errors. This means the ERA will only be valid if the APR is latch with an error.
4. If ERA channel ref. = 1 and data SRC = 0,0 write =:Ø Go to DMA or MA/MB to MB's.

12. Compare data that the command list was trying to transfer.
13. A conl from the RH20 can also be issued to determine device failures, refer KLHB Page 44.
14. Run DFSXA, DDRPI with MAX controllers and drives.
Run DGKBD and DGKBE with clock margins.
15. The following will allow you to look at the DCL Registers. The example is for RH20# 0 but can be applied to any RH20 and any Register.
 - a. Cono to Enable MASSBUS
 > EX 754020 400
 - b. Status for RH20 #0 Drive #0
 - c. Select Register #2 or ERR #1
 > DM 16: 20400 0
 - d. DATAO
 > EX 754140 16
 - e. Datai To Read ERR #1
 > EX 754040 17
 > EM 17
 - f. Select Register #14 or ERR #2
 DM 16: 140400 0
 - g. DATAO
 > EX 754140 16
 - h. DATAI to read ERR #2
 > EX 754040 17
 > EM17
 - i. Select Register #15 or ERR #3
 > DM16 : 150400 0
 - j. DATAO
 > EX 754140 16
 - k. Data to Read ERR #3
 > EX 754040 17
 > EM17
 - l. To look at other registers just change bits 0-5 in location 16 to the desired register.

H. IO PAGE FAIL ERRORS

1. This is latched in APR
2. It indicates a page trap occurred while a PI was active.
3. The Page fail word is held in AC BLK 7 location 2.
4. Check to see if any other APR errors are latched. i.e. MB PAR ERR.
5. IO page fails typically happen when the MBOX gets locked up by the channel and we have a bad data transfer.
6. The halt loop may not be forced.
7. If PARSER echoes PAR> use the addendum to collect data.
8. By stopping the KL, FXCTØ, you can find who was doing the PI. from the trace dump.
9. The DTE can also give an IOPE fail, however, if the EBUS data was bad going into the AR you will see EBUS parity ERROR set.
10. The only place EBUS Parity is checked is from the DTE.

I. DTE FAILURES

1. DTE failures can be indicated by many symptoms.
2. The 11/40 may show traps.
3. DEX errors may occur.
4. Keep alive cease may occur (not always the DTE)
5. AR traps may occur
6. EBUS parity Errors may occur.
7. And as before IOPG fail errors.
8. Look at DTE status and determine Error or Transfer type Error.
EE 174434
9. If bit 09 set = MPE11 suspect an 11/40 memory or Bus Problem.
10. Other errors, T01ØER, T011ER can naturally be the DTE modules, however, these bits will tell you which way the transfer was going.
11. To collect all data about the RAMS in the DTE...
EE 174400 thru 174436

V. The following is for errors where Parser indicates #; or clock stop errors.

Function Reads 103 - 105 will tell type of error.

A) FM PAR ERR

- a. Use tracon to collect data. Registers will indicate which FM block and address was being used.
- b. Adder or AR will indicate data being transferred to or from FM.
- c. FM register will be printed, this should indicate some discrepancy from the destination of memory or AR or Adder.
- d. Decode the M8512 with failing BIT.
- e. Note: the FM Parity and Select Logic is on the APR M8539 board.
- f. Use DGKAB and Processor functionals at clock margin to isolate.

B) CRAM & DRAM ERRS

- a. TRACON will give location of failing address and data.
- b. Easiest method to isolate is to collect data from location and then verify it with the good micro code location.
- c. If it is the customers microcode you may need to verify it via KLI.
- d. Example: 207 in switch register.
 - 1) enable switch register
 - 2) system prints out KLI enter dialogue
 - 3) KLI> - Yes
 - 4) the system asks to reload microcode, say verify
 - 5) KLI> - VERIFY

e. Bad location and data should be printed out.

f. Decode to board with KLHB
Page 28 - 31

NOTE: These are basic data path failures and basic procedures to isolate them. However, there are many conditions we cannot predict, thus some deviation may be necessary.

I have not discussed in detail failing control modules, however, using the information in this text should get you in the ball park and allow you to intelligently diagnose a control board failure.

IF PAR > The KL is doing some type of micro code loop-

CAUTION: At this point we must be very cautious as many of customer packs and KLAD have been destroyed here.

I.

1. If PARSER echos PAR you can stop the KL10 in it's tracks and safely mount the KLAD by the following:

a. PAR > SET CON MAI

b. PAR > FXCT Ø

c. PAR # will echo

d. now mount KLAD as normal (be sure to turn off all customer packs or at least write protect them)

2. Now load KLDCP as normal.

3. Load TRACON to snapshot machine.

P TRACON

Sed

* LP

* Answer Yes

* / : will give you questions as before

* D will dump machine state at FXCTØ time.

* G will print the entire loop the machine is in, including signals and microcode

4. Now reset the microcode to the Halt Loop.

a. FXØ ; turn off clocks

FX7 ; set reset

ECØ ; set up u code

FX6 ; clear reset

FX1 ; turn on clocks

FXØ ; turn off clocks

EC ; should be halt loop for system microcode (refer to fiche)

5. Now you can execute instructions; look at the RH20; the channel or ERA. Remember the EBOX has been reset.

II. The following procedure may be followed to collect data and this should prevent pack destruction.

1. First assure the KL10 did not continue time sharing, i.e. no reload patch in incorrectly.

PAR > QUIT

"Tops 10"

. ^ C ^ C

. SYSTAT

"Tops 20"

@ ^ C ^ C

@ SYSTAT

2. If terminals are dead and you get no response from the CTY you can be assured the KL is out there doing something it whouldn't be.

3. Back to PAR >

4. We will collect as much information from the command parser as possible, as mounting the KLAD will probably result in pack destruction, or loss of symptom. Again caution - any command given to the KL may be taken and executed by it resulting in ????????

5. Refer to parser Help File

ATTACHMENT A

(1)

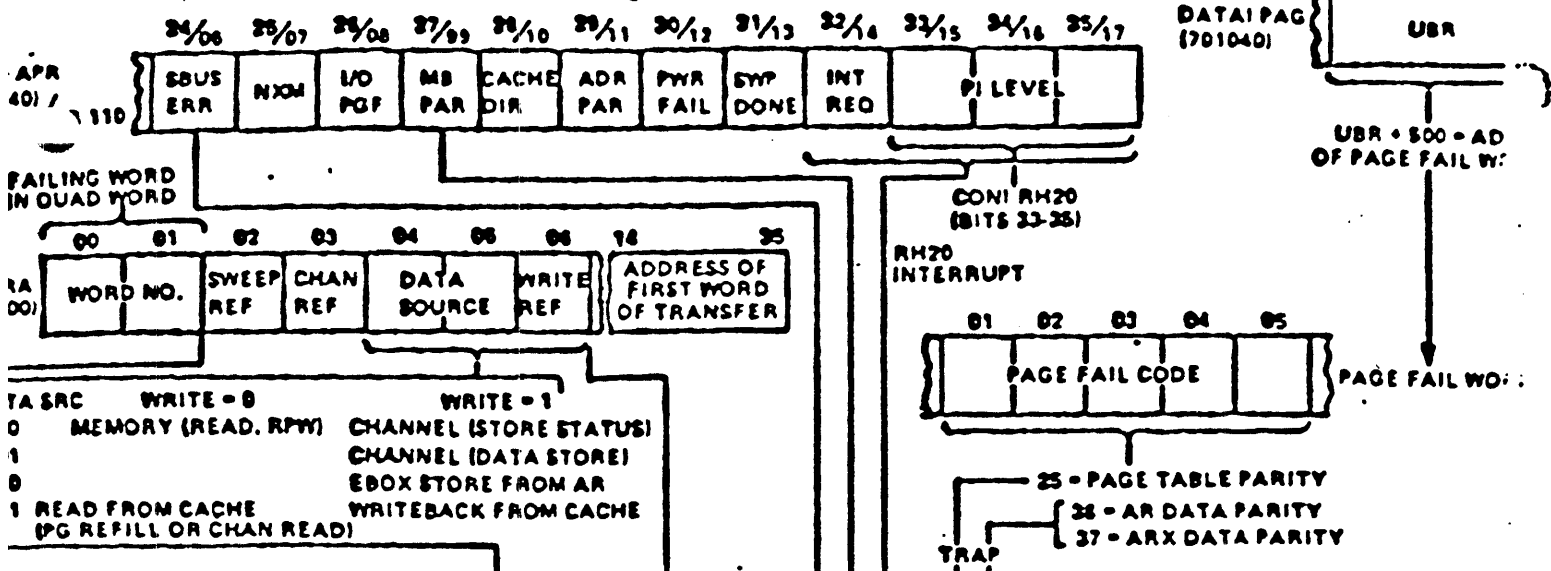

MEMORY EXT/INT)	CACHE	OPERATION	WHERE DETECTED				SWEEP REF	CHAN REF	DATA SOURCE	WRITE REF	COMMENTS	SBUS ERR	MB PAR	INT REQ(RH)	PI PARITY	AR/ARX PAR	FAILING COMPONENT OR DATA PATH
			DMA20	MB	AR/ARX	PT											
OFF	READ		X	X	X			0	0	0		1		X		MB to AR/ARX DMA to MB DMA to MF/MG to DMA MB to PT or PT	
			X	X		X		0	0	0	READ OR RPW			X		DMA to MB DMA to MB DMA to MF/MG to DMA	
			X	X		X		0	0	0						MB to DMA AR to MB	
	WRITE		X	X				1	0	1							
			X	X				1	0	1							
			X	X				1	0	1							
EXT. 180/1090	ON	READ		X	X			0	0	0		1		X		AR to CACHE or CACHE or MB to AR/ARX DMA to MB DMA to MB DMA to MF/MG to DMA DMA to MF/MG to DMA	
				X	X		X		0	0	0	EBOX READ			X		
				X	X		X		0	0	0				X		MB to PT or PT DMA to MB DMA to MB DMA to MF/MG to DMA DMA to MF/MG to DMA
	WRITE (EBOX)		X	X				1	0	1							AR to MB CACHE to MB or CACHE MB to DMA
			X	X				1	0	1							CACHE to MB or CACHE MB to DMA
			X	X				1	0	1							MB to DMA
ON	RPW		X	X			0	0	0							X DMA to MB X DMA to MF/MG to DMA X AR to CACHE or CACHE or CACHE to AR/ARX or MB to AR/ARX	
			X	X				0	0	0							

RY NT)	CACHE	OPERATION	WHERE DETECTED							COMMENTS	SRUS ERR	MB PAR	INT REQ(RH)	PT PARITY	AR/ARX PAR	FAILING COMPONENT OR DATA PATH
			DMA20	MB	AR/ARX	PT	RH20	SWEEP REF	CHAN REF							
OFF	OFF	READ (CHAN DATA)	X	X			X	X	0	1	0	0	0			MB to RII to MASSBUS or MASSBUS DMA to MB DMA to MF/MG to DMA
		WRITE (CHAN DATA)	X	X					0	1	0	1	1			MB to DMA RH to MB DEVICE to RH
		READ	X	X			X		0	1	0	0	0			DMA to MB DMA to MF/MG to DMA
		WRITE	X	X					0	1	0	0	1			MB to DMA RII to MB
ON	ON	READ	X	X			X	X	0	1	0	0	0			MB to RII DMA to MB MB or AR to CACHE to MB DMA to MF/MG to DMA
		READ CCW	X	X					0	1	0	0	0			DMA to MB MB or AR to CACHE to MB DMA to MF/MG to DMA
OFF	OFF	READ		X	X					0	0	0	0			MB to AR/ARX MB to MA/MB20 to MB MB to PT or PT MA/MB20 to MB MB to MA/MB20 to MB AR to MB
		WRITE		X						1	0	1				
		RPW		X	X					0	0	0				
ON	ON	READ		X	X					0	0	0	0			AR to CACHE or CACHE or MB to AR/ARX MA/MB20 to MB MA/MB20 to MB MB to PT or PT MA/MB20 to MB AR to MB
		WRITE (EBOX)		X						1	0	1				CACHE to MB or CACIE CACIE to MB or CACIE MA/MB20 to MB
		(SWEEP)		X					1	0	1	1				AR to CACIE or CACIE MB to MA/MB20 to MB
		RPW		X	X					0	0	0				
OFF	OFF	READ (CHAN DATA)	X				X		0	1	0	0	0			MB to MA/MB20 to MB MB to RH MB to MA/MB20 to MB
		WRITE (CHAN DATA)	X				X		0	1	0	1	1			RII to MB DEVICE to RII
		READ	X						0	1	0	0	0			MB to MA/MB20 to MB
		WRITE	X						0	1	0	0	1			MB to MA/MB20 to MB
ON	ON	READ	X	X			X	X	0	1	0	0	0		MB to RII MB to MA/MB20 to MB MB or AR to CACHE to MB	
		READ CCW							0	1	0	0	0		MB to MA/MB20 to MB	
		READ							0	1	0	0	0		MB to MA/MB20 to MB	
		WRITE							0	1	0	0	1		MB or AR to CACHE to MB	

PG = Parity Generation
PC = Parity Check
XC = clock stop parity

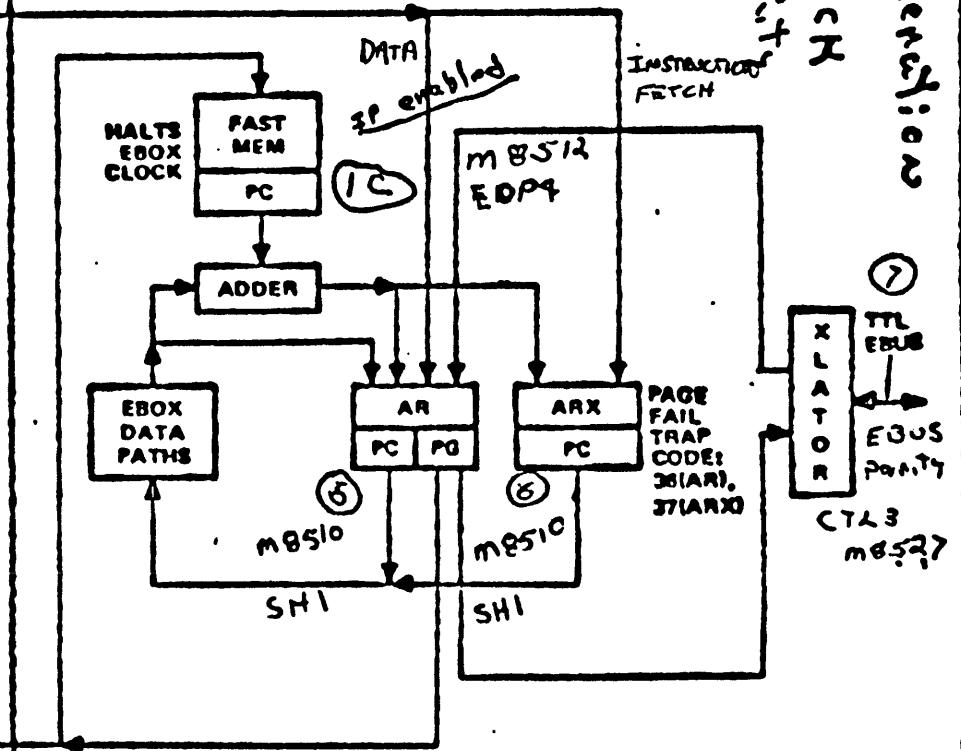
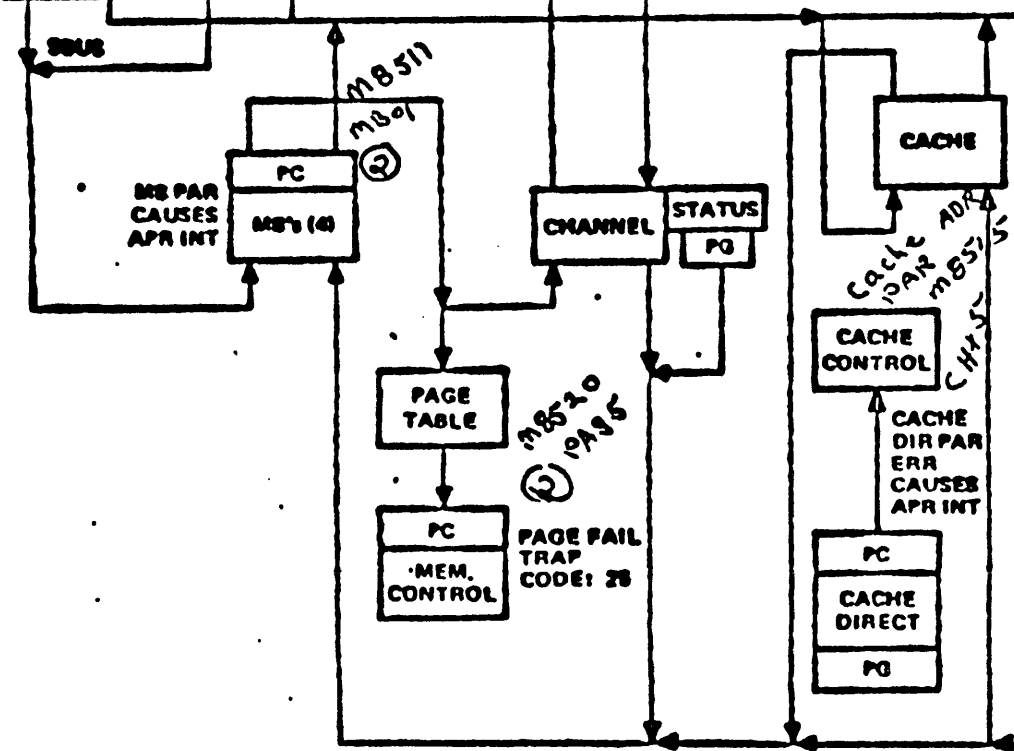
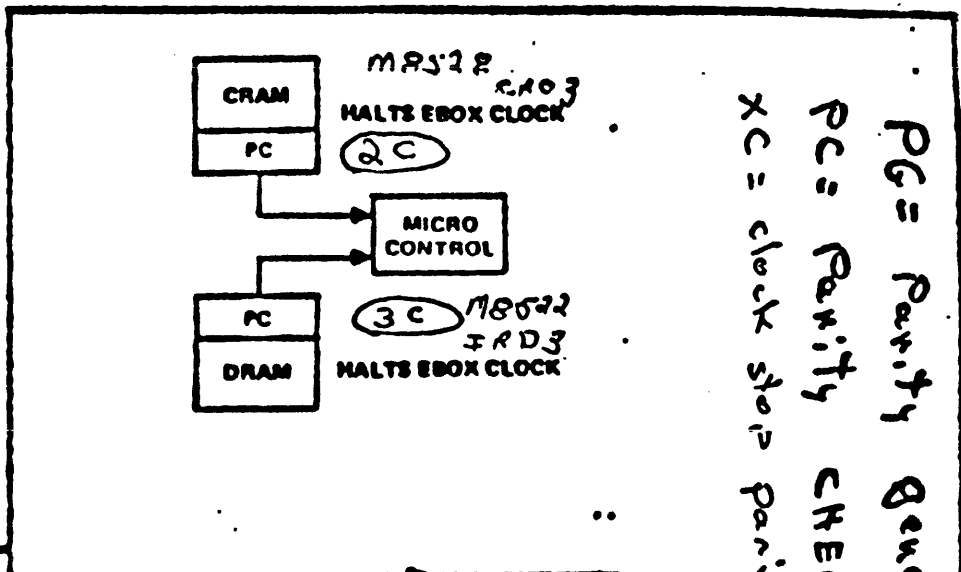
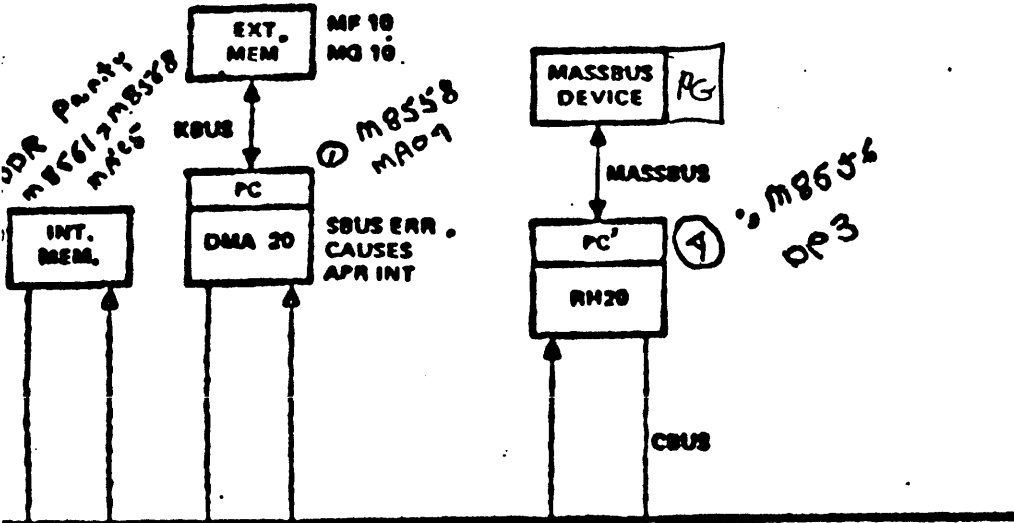

PG - PARITY GENERATOR PC - PARITY CHECKER

FUNC READ	BIT	SIGNAL NAME	ATTACHMENT C	TRUE STATE
103	30	CLK3 DRAM PAR ERR		1
104	30	CLK3 DRAM PAR ERR		1
105	30	CLK3 FM PAR ERR		1
106	30	CLK3 FS ERR		1
107	30	CLK3 ERROR		0
110	06	APR1 SBUS ERR IN		1
110	07	APR1 NXM ERR IN		1
110	08	APR1 I/O FF ERR IN		1
110	09	APR1 MB PAR ERR IN		1
110	10	APR2 C DIR P ERR IN		1
110	11	APR2 S DIR P ERR IN		1
110	12	APR2 FWR FAIL IN		1
160	16	MBZ4 CHAN PAR ERR		0
160	25	MBZ3 CHAN NXM ERR		0
161	15	MBZ4 MBOX AIR PAR ERR		0
161	22	MBZ3 MBOX NXM ERR		0
161	24	MBZ4 MBOX SBUS ERR		0
162	15	MBZ4 CHAN AIR PAR ERR		0
162	24	MBZ4 MBOX MB PAR ERR		0
171	01	CRC4 RH20 ERR IN		1
171	02	CRC4 DUN ERR IN		1
171	03	CRC4 SHORT WC ERR		1
171	04	CRC4 LONG WC ERR		1
172	03	CRC3 CRC ERR IN		1
177	22	CSH6 PAGE REFILL ERROR		0

Field Service Location Stops

Processor Errors : MB537
 MB23 - MB24

Channel Errors : MB535
 CRC9

Transmission Errors :
KL10
 4E10V2

SUBJ: TROUBLE-SHOOTING IN A KL10 WORLD
FROM: P. Clark

Rule #1: Expand your Horizons

Rule #2: Attack with Confidence

Rule #3: Confirm your fix

Rule #4: Don't chalk it up

Rule #5: Document your actions

Rule #1 - EXPAND YOUR HORIZONS

A) Make sure you are shooting the simplest of all problems while understanding the large picture concept. This means, when given a diagnostic failure don't restrict yourself. Run more basic diagnostics and more sophisticated diagnostics. Get the whole picture before you start trouble-shooting.

1) If you are dealing with a processor or memory failure which is evident using a portion of B.CMD, always use diacon. Test loop, with print all errors set throughout the full span of the diagnostic, exposing all failures of the diagnostic in question. Don't forget to run some of the more sophisticated ones.

2) When you have found the simplest method of reproducing the problem start trouble-shooting.

B) Without exception, check power first.

1) Make sure you know the specs for both DC + or - limits and ripple. It's ridiculous to check something if you don't know what you are looking for. If you don't know the specs, its time you knew; find out. If possible look it up; if you ask someone salt the answer. They may be wrong.

For DC limits - use a DVM. The VOM is not good enough. Always check at the backplane. Stay on the tab for enough time to assure yourself that the supply is not fluctuating (about 10 seconds). Voltage checking is an important aspect of your trouble-shooting procedure. If you have 15 tabs you should not be done in 15 seconds.

Ripple - use the scope to check ripple.

- 2) Check the fans in the power supplies.¹ Overheated supplies can cause intermittent problems by dropping voltage for small periods of time or raising some power low condition. If you find a bad fan stop, think, do not immediately power down the machine. Can you reproduce the original problem after a power down? If you are not 100% sure, gather as much data as possible before removing power. The fan has probably been out for 29 days anyway (based on one month PM's).
- C) Use the scope before you power down the machine to replace a module. Make sure the problem is not backplane related. Using the scope will always increase your technical ability. You will learn your way through the prints; you will learn what signals to expect; you will learn the machine in better detail than if you had blindly replaced a called out module. Subrule: If you don't understand what you are dealing with, think; if you still don't understand, ask for help (remember the objective is to learn, learn and fix with minimum loss).
- D) Don't let evidence slip by you. If you get tired of watching "NO FAULT" - "NO FAULT" - etc., remember to set the diacon switch and restart the diagnostic. Now say PS. (cr) - "PRINT SYMPTOM". You will get the last detected error. Don't let this opportunity slip by. The problem may be intermittent and every bit of input counts.

- E) Summarizing, Rule 1 means gather as much data as possible before you start to change things. This will help you later to determine if other faults were introduced by your actions or if these are symptoms of the original problem.

Rule #2 - ATTACK WITH CONFIDENCE

- A) Control all aspects of your approach so as to ensure that you have complete confidence in every move.

- 1) Organize and direct your actions. Perhaps an approximation of the scientific method is useful.² Having gathered as much data as possible concerning the failure consult the prints, manuals and all other available sources. Generate a theory (make a reasonable guess as to the cause of the problem). Devise an experiment which will prove or disprove your hypothesis. Perform the experiment with control. If you have decided to replace a module, you must be sure that this replacement is the only variable. This means first going through the motions pretending to replace the module without having actually done so. Power down the machine. Go to the rear and open the doors. Find out what you will be dealing with when replacing the module.

(Perhaps you will open the logic doors and peer inside.)
See what you recognize; see what you don't understand;
take a minute to reconsider your past and future actions.
Return to the front of the machine and restore power.

Reproduce the problem. Now you can be sure that module replacement will be a controlled experiment.

2) Analyze the results. If the outcome is not what you expected something is wrong. Perhaps you have introduced a new problem or maybe you miscalculated initially. If upon further reflection you cannot positively identify the cause of the original problem go back. You have learned something but it is probably not what you wanted to know.

B) Don't swap indiscriminently. Buses seldom fail. There is no excuse for the plugging and unplugging of inactive components. While attempting to isolate, be sure your swap is leading you to a visible end - don't react blindly.

C) Maintain your level of confidence throughout all replacements.

1) If a swap does not fix the problem, make sure you perform the exact counter-swap before proceeding. Also restore your assurity that the problem has not changed or become more complex. If you feel you are getting deeper and deeper, you need help - remember to think and if you see no light, call for assistance whenever things seem glum.

2) Make sure you are on the right track. Perhaps a multiple-module-swap seems inconsistent with the level of troubleshooting which we have been discussing. Never-the-less, when performed with caution and confidence this method can be a tremendous aid. To be certain, you have localized the area of failure, perform a well calculated.

multi-module-swap. You can cover considerable ground using this technique but BE CAREFUL. Pay attention to details: module location (use the MUL); jumpers; keep track at all times of stock vs machine modules. If the problem begins to mushroom drop back - the method of successive approximations can turn into the method of successive abominations.

D) So: Rule #2 = confidence. This means you completely understand what you are doing at each step. When confused stop, think and backspace, one step at a time. Never go off on tangents unless you feel confident of a safe return to the norm.

e #3 - CONFIRM YOUR FIX IN THE SEMI-FINALS

When you have determined that a replacement has eliminated the failure in question:

First - Assure yourself that the system is totally useful. Run the full B.CMD script. If possible bring up the monitor or other normally used operating system.

Now - Unless damage to the system can occur, confirm your fix. Reinsert the suspect component to maintain your confidence that this replacement is the true solution to the problem.

Then the Finals - Again replace the bad module and bring up the system.

If a confirmation fails, your solution is not final and you should pay special attention to Rules #4 and #5.

Rule #4 - DON'T CHALK IT UP TO A FULL MOON

If somewhere along the line the system has restored itself or the problem has in a similar way evaded you, don't dismiss it as a hex or temporary dizzy spell. Unsolved problems will reoccur. Be sure you cannot reproduce the problem - make a sensible reliability run - If all else fails return the system, compile all the data you have collected, make sure the responsible Engineer is aware of the problem and pay close attention to Rule #5.

Rule #5 - DOCUMENT YOUR ACTIONS (with exception)

Remember the sooth-sayer on the potty: "the job's not finished till the paper work is done."

Detail your failures as well as your accomplishments. Too much time can be lost by future activity in areas you have already eliminated. Recompile your notes. Make comprehensive entries in the system log explaining your actions and the corresponding achievements or setbacks.

Exception: If you are confused your input means little if anything at all; remember to seek assistance whenever necessary even when analyzing the true progression of your actions. If it will help to make things clearer to the next Engineer attacking the problem, discuss your notes with a friend before you make a final draft. Don't make dragons out of lizzards.

FOOT 1: Special thanks to Tom Albro for contributions leading to an expansion of my simple "without exception check power" statement. Tom recounted a recent incidence where, in a peripheral device, stopped power supply fans introduced a highly intermittent problem. It was a punishing experience for all of us.

(2) FOOT 2: The scientific method was incorporated into my original draft text as a result of suggestions made by Dave Russell, the first Proof-Reader.

FINAL NOTE: This blurb is by no means a bible or the final word on troubleshooting. There undoubtedly are many documents available which describe with wider scope the accepted methods for general troubleshooting. Conversely, I am not undermining the points made here. Caution and lucid thinking are some of the most powerful tools available to you. Always expand your web to the furthest extent possible. In this way, you will sense danger approaching before it engulfs you. Remember, to the tiny arachnid, such as you or I, even a Lizzard can be pretty scary.

"KL10 MAINTENANCE SEMINAR"

Pre-requistions: This course assumes you have attended a course of instruction on the KL10 theory and maintenance. You should have a functional knowledge of the Dec 20 or KL10 internal layout. And a basic knowledge of KLDCP and the diagnostics used to maintain the system.

Summary of Information:

- 1) Parity network and errors
- 2) Understand which errors will cause an APR interrupt, which will cause clock stops, which errors will result in an interrupt due to an associated error.
- 3) Isolation data
 - a. ERA
 - b. APR
 - c. S-bus diagnostics
 - d. page fail
 - e. RH20 logout area
 - f. function reads
 - g. conl information
- 4) Extension programs to isolate failures
 - a. conex
 - b. trace
 - c. tracon
 - d. diacon
 - e. diamon
 - f. magmon
- 5) Collecting data on crashed system
 - a. procedure
 - b. know how to expand on information
 - c. do's and don'ts
- 6) Diagnostics - margining - which will fail?
- 7) Board rotation and swapping
 - a. do's
 - b. don'ts
- 8) Field Service stops
- 9) Command parser
 - a. using to isolate KL

The following
are miscella-
neous software
items for dis-
cussion:

- 10) Syserr
 - a. what to believe
 - b. what not to believe
- 11) Generations a command list for; halted, hung KL
 - a. text command
- 12) Patching diagnostics
 - a. some new patches
- 13) Using MAGTAP.SAV for diagnostic transfer
- 14) Transferring new diagnostics from tape to ll side of KLAD
- 15) KLAD 20
- 16) KLAD 10
- 17) Bughalts ver 2 and 3
- 18) Stop codes 603
- 19) ll stop codes
- 20) Large buffer - index for monitor patches
- 21) Some monitor locations for debugging
 - a. tops 20
 - b. tops 10

III. The basic procedure will be as follows, however, each error will be treated differently as we progress through information collection.

A. Bring up and inilitize KLDCP

- 1. Mount KLAD
- 2. PAR% MCR BOO,
- 3. BOC% DGCEY now in KLDCD

B. Collect data starting from 11/40 and work toward 10.

- 1. FX0 Assure clocks off
- FR 110
- FR 160, 162 Collect all error bit.
- FR 171, 172 Refer to attachment to
- FR 177 decode bits.

This will give you a basic idea of the type of error seen.

C. Load TRACE or TRACON and get snapshot of KL10

- 1. Tracon
 - SED
 - /
 - *D
- This will allow us to answer questions for maximum information.
This will dump the KL10 in neumonics and give you an indication of the failure and what the KL10 was doing.

D. Back to KLDCP

- 1. FX1 Turn clocks on
- 2. AC BLK 7 Select u-code BLK
- 3. EMO 0=AR
- 4. EM1 1=ARX
- 5. Ac Blk 0

E. Collect error information

- 1. EX 700400 5 Read and collect ERA *ONLY VALID IF APR HAS ERROR BIT*
- EM 5 *MORE ON OTHER LISTINGS*
- 2. EX 700240 6 Read and collect APR
- EM 6

IV. At this point the procedure will depend on the error indication, from FR's, and system type. We will discuss each error individually.

Note: The following information should be used in conjunction with the KL10 handbook and the chart for errors in this text.

DEC 20XX MA/MB

A. 1. MB PAR ERR

- a. The MA/MB do not use RD or WR parity checking.
- b. Look at ERA determine direction of cycle and type from data SRC.
- c. If CHAN Ref = 0, ^{Q AND MEM READ.} start at MA/MB and work toward MB's.
- d. Address will indicate storage module - decode with print set for amount of memory and intv.
- e. If write Ref = 1 data SRC = ~~0~~ start at AR work toward MB.

FIT ON OTHER LIST.

1, 0

2. SBUS ERROR

- a. In the MA/MB SBUS ERR comes from an incomplete request.
- b. The ERA^{WORD NUMBER} will be invalid, however, the base address will still be held.
- c. Use conex and SBUS diagnostic to determine controller
 - > P-Conex
 - > SED
 - > SD
 Controller=X
 Function Code=0
 Change Inter.=N
 Reset Errors=N
 xxxxxxxxxxx=data
 Bit 2 will tell which controller sent the error.
 If no INC/cycle start at SBUS translators, M8519; and work toward controller.
- d. If channel Ref = 1 from MB to AR (discussed later)
- e. Run DGKBB, DGMMA at clock margins

3. SBUS ADDRESS PARITY

- a. Read ERA - address is Latched. DATA SOURCE INVALID
- b. Use SBUS diags to determine which controller received the ERR.
- c. Check translators for failing bit.
- d. DGKBB will isolate bit.

4. NXM's

- a. There are two types one for the M box and one for the MA/MB.
- b. M box NXM are when after the memory request no ACK comes back for 64 microsec.
- c. APR will show error bit. ^{BITS 34 AND 35}
- d. If ERA WD # is equal to base address then the NXM is from the M box.
- e. In this case start at controller work toward translators.

- f. Also, the M box control logic may be at fault.
- g. Run DGKBA.
- h. If ERA word# is not equal to the base address then the the MA/MB lost one of the QUAD word requests, 8 microsec time out.
- i. Decode storage module using WD# for bits 34, 35 of base address, work back to translators.
- j. Isolate with D&KBB, DGMMA - or 10/based memory diagnostic. Run clock margins.

K ON OTHER LISTING

B. 10XX - DMA

MB PAR AND SBUS ERROR

1. DATA PARITY ERR are checked on both MG/MH10 memories.

- a. MB PAR will be latched in APR.
- b. SBUS diagnostic will show error and ADDR.
- c. Rule out memory first.
- d. Determine K-bus from S-bus diagnostic.
- e. Be sure ERA does not indicate a channel ref.
- f. Start at M8558 work toward translators.
- g. Run DGKBB for DMA
Run DGMMA or 10/based memory diagnostic for MG/MH
- h. ERA will be invalid for address because SBUS ERR will be asserted, however, base address and cycle are still valid.

ADDITIONAL ON OTHER LISTING

2. SBUS ADDR Parity

- a. Checked in DMA on RD - WR
- b. ERA is VALID
- c. Determine address from ERA
- d. Decode K-Bus from WD#
- e. Start at M8558 work toward translator - remembering the address is gated through the M8560.
- f. Check de-skew
- g. Run DGKBB or address test under 10/based diagnostics

3. NXM's

- a. Again there are two types M box - DMA
- b. Treat M box as before, however, start at DMA M8563
- c. If DMA NXM, = 28 microsec time out between word requests, start at K-Bus M8558 from ERA.

- d. Work toward translators.
- e. Run DGKBB - DGMMA with clock margins.
- f. Check DE-Skew.

G. ON OTHER LISTINGS.

C. CACHE FAILURES

- a. Cache failures may be hidden by what appears to be memory problems or DMA failures.
- b. The ERA will be the biggest help.
- c. Ifwrite = 1 and data SRC = 1,1 start a cache and work toward MB
- d. A good indication of a bad cache quarter is if the last three OCTAL digits of the failing addresses are always the same or within the same modulo four address.
- e. If a cache error is reported along with SBUS go back to DMA work toward MB's.
- f. If write = 0 and data SRC = 1,1 your are doing a chan ref. or page refill and problem can be from MB to AR to cache - start at MB's then cache if no AR/ARX parity ERR.
- g. Cache problems can also be reflected as AR/ARX parity errors - see AR/ARX section.
- h. Run DGMCA - DGMCB - clock margins and run DFKDA.

D. CACHE DIRECTORY PARITY ERRORS

- a. APR will indicate error.
- b. Use ERA it will indicate sweep reference and address will show line number by last three digits ~~address~~^{OCTAL}.
- c. Truly an address parity error.
- d. Start at address logic M8515 work toward PMA - via the M8523 VMA board. If we are doing a cache E box cycle.
- e. The M8514 comes into play by holding the actual cache directory information.

E. PAGE TABLE PARITY TO PAGE FAIL ERROR

- a. First we can collect the page fail word via KLDCP.

EX 701040 5	Data;	Page = UBR
EM 5	Data;	Right half is UBR
		refer KLHB page 37
- b. UBR + 500 = Page fail word.
- c. Refer KLHB Page 33
- d. Right half = address.
- e. Use left half to decode page fail code.
- f. If Page table parity start at hardware pager M8520 work toward MB's.

- g. If Page refill and SBUS error go back to DMA to MG or MA/MB to translators.
- h. The M8513 controls much of the refill logic.
- i. If Page fail code equals 36 or 37; go to AR/ARX section.
- j. Note: MB PAR will be set in conjunction with Page table errors.
- k. Run DFKDA clock margins, run DFKEA clock margins.

F. AR/ARX PARITY ERRORS

- a. Page fail code of 36 or 37 occurs.
- b. AC BLK 7 location 0 + 1 will contain data.
- c. Note: MB parity ERR may or may not be set. The AR/ARX is a final catch all for errors not detected elsewhere. Caution should be taken as these errors may be misleading, however, if close detail is noted when looking at the ERA it will simplify matters greatly.
- d. If ERA data SRC = 0,0 + write = 0, then go back to MA/MB to MB's or DMA to MB's.
- e. If no MB PAR then start at MB, work toward AR/ARX.
- f. If cache present; a problem can be from AR to cache, or cache to MB, or MB to AR/ARX but only on a data SRC of read. Otherwise sweep would be set.
- g. Run the system exerciser, 20 = DFSXA; 10 = DFSXA-C clock margin. WITH SWITCH 7 SET
- h. Check DE-Skews.

REMEMBER!!
 MUST HAVE ER
 FLAG SET IN API
 FOR ERA TO BE
 VALID!! AR/ARX
 PAR ERR IS
 NOT APRER
 FLAG!!

OTHER
 LISTING

G. CHANNEL ERRORS

- a. Channel errors can be quite misleading, but again, noting the ERA will simplify matters.
- b. Function reads 162 - 171 - 172 will give errors.
- c. Note: All channel error will not result in an APR interrupt until they are detected coming out of the MB's, or back as address errors.
- d. If ERA channel ref. and dta SRC = 0,0 write = ϕ : Go to DMA or MA/MB to MB's.
- e. If channel = 1 and write = 1 with FR 171 bit 1 set and data SRC 0,1 start at device, RPOX, TU45 and work toward RH20.
- f. If channel = 1, write = 1, data SRC = 0,1 and no channel error start at RH20 and work toward MB's.
- g. If channel = 1, write = 0, data SRC = 1,1 problem can be from MB to cache or AR to cache.

↑
 SEE ABOVE!

RH20 ERR

- h. The TRACE or TRACON data from when you dumped the machine will be very valuable to isolate the failure as it will indicate signals active.
- i. The RH20 logout data can be very useful at this point.
1. EX 701240 5 Coni page
EM 5 EBR probably will be 2000
 2. Determine which RH20 was issuing the command from TRACON. If unable to; then look at all RH20 logout areas.
 3. Formula for determining logout area:
RH20# x 4 = decimal area: convert to octal.
 4. Octal # + EBR = beginning of logout area.
 5. Example: RH20# 3, $3 \times 4 = 12$, 12 decimal = 14 octal
ERA = 2000
 6. Logout area = 2014 = WDO
 2015 = WD1
 2016 = WD2
 2017 = WD3
 7. Refer KLHB Page 26-27 WDO = jump to command list
WD1 = errors and CLP, WD2 = current CCW.
- j. You can now use conex to simulate the channel command the system was doing and see where the failure occurred. Refer KLHB 97-99 and conex help file.
- > PConex
- > Sed
- > Set Channel X Set to appropriate.
- > Set EBR Y Channel # and EBR# from above.
- > SC *
- > TM * Command: Start, Reset.
This will issue and execute the command that the system was doing and can be compared to logout area.
- k. Watch for word count changes or discrepancies or address problems.
- l. Compare data that the command list was trying to transfer.
- m. A coni from the RH20 can also be issued to determine device failures, refer KLHB Page 44.
- n. Run DFSXA, DDRPI with MAX controllers and drives
Run DGKBD and DGKBE with clock margins.

V. The following is for errors where Parser indicates #; or clock stop errors.

Function Reads 103 - 105 will tell type of error.

A) FM PAR ERR

- a. Use tracon to collect data. Registers will indicate which FM block and address was being used.
- b. Adder or AR will indicate data being transferred to or from FM.
- c. FM register will be printed, this should indicate some discrepancy from the destination of memory or AR or Adder.
- d. Decode the M8512 with failing BIT.
- e. Note: the FM Parity and Select Logic is on the APR M8539 board.
- f. Use DGKAB and Processor functionals at clock margin to isolate.

B) CRAM & DRAM ERRS

- a. TRACON will give location of failing address and data.
- b. Easiest method to isolate is to collect data from location and then verify it with the good micro code location.
- c. If it is the customers microcode you may need to verify it via KLI.
- d. Example: 207 in switch register.
 - 1) enable switch register
 - 2) system prints out KLI enter dialogue
 - 3) KLI>- Yes
 - 4) the system asks to reload microcode, say verify
 - 5) KLI>- VERIFY

PAR # APPENDUM

(1)

e. Bad location and data should be printed out.

f. Decode to board with KLHB
Page 28 - 31

NOTE: These are basic data path failures and basic procedures to isolate them. However, there are many conditions we cannot predict, thus some deviation may be necessary.

I have not discussed in detail failing control modules, however, USING the information in this text should get you in the ball park and allow you to intelligently diagnose a control board failure.

BASIC PROCEDURE FOR GETTING ERROR INFORMATION ON AN INTERMITTENT
KL10 OR DEC20

Assumptions - KL10 monitor 6.03 + VER. 6A RSX20F
DEC20 - TOPS20 VER. 2 + RSX20F.
VER. 157 microcode

"This procedure will work on earlier versions with some modification to the loading procedure."

- I. First we must set no reload so the ll-front end will not reboot the system upon a detection of a crash. (Underlined statement you will type.)

```
DEC20: @ CONTROL BACKPLASH (Go to PARSER)
        PAR SET CONSOLE MAINTENANCE
        PAR SET NO RELOAD
        PAR QUIT (back to monitor)
```

KL10:	At present; setting no reload under RSX20F alone will not keep KL10 from reloading. You must also change a monitor location as follows:	If the problem is intermittent a better method is as follows:
		.R FILDDT
		File: <u>System/s</u>
		File: <u>/M/P</u>
		Debug <u>/440000,,0</u>
		This will disable auto reload and will halt the system
		^Z
		This must be re-done after each crash.
	BTS> <u>System/L</u>	
	BTS> <u>/401</u>	
	BTS> <u>/G</u>	
	(Now in EDDT)	
	Common \$:	
	<u>BNXMTS +1/cono 10,0</u> <u>HALT</u>	
	<u>Debug G</u>	

- II. When the system crashes it will halt upon the detection of an error and will not reload.

- A. On the CTY or remote KLINIK LINK: Type ^ \
- B. Parser will now echo one of three prompts:
= clocks stopped
> = KL10 running
% = KL10 halted
- C. If parser echoes PAR> ... go to addendum for PAR> procedures.
- D. If parser echoes PAR#... go to addendum for clock stop errors.
- E. If parser echoes PAR% the KL10 is halted and collect data as follows:

IF PAR> The KL is doing some type of micro code loop-

CAUTION: At this point we must be very cautious as many of customer packs and KLAD have been destroyed here.

The following procedure may be followed to collect data and this should prevent pack destruction.

1) First assure the KL10 did not continue time sharing, i.e. no reload patch in incorrectly.

PAR QUIT

"Tops 10"
.^ C ^ C
.Systat

"Tops 20"
@ ^ C ^ C
@ Systat

2) If terminals are dead and you get no response from the CTY you can be assured the KL is out there doing something it shouldn't be.

3) Back to PAR>

4) We will collect as much information from the command parser as possible, as mounting the KLAD will probably result in pack destruction, or loss of symptom. Again caution - any command given to the KL may be taken and executed by it resulting in???

5) Refer to parser Help file

PAR> SET CON MAINTENANCE

6) PAR> WHAT PARITY

Assure yourself that the FM CRAM, DRAM parity stops are enabled. If not, enable them and watch for KL to stop clocks #, with error.

7) PAR> FREAD "103-110"
160, 161,
162, 171,
177

Do fuction read individually and refer to error chart to assure no errors are latched but have not been serviced.

8) PAR> FREAD 144, 145

will give CRAM ADDR.

9) PAR> EXAM AD, ADX
AR, ARX
BR, BRX
VMA, VMH

this will get all KL10 registers.
Note: they may be changing.

SET CONS MAINT
FXCT 0 (STOP CLK
LOAD KLDCP
TRACE
SED
/
K G

TO FORCE-HALT
AND RESET BOX
7. FX 0
7. FX 1
7. EC 0
7. PL 0 0
7. FX 0
7. FX 1
7. FX 0
7. EC
(SHOULD BE
HART LOCK

PAR> ADDENDUM
(1)

- 10) PAR> REPEAT 10; EXAM PC will give you 10 sequential PC locations. Try to establish a loop for software to reference.
- 11) PAR> DIAGNOSTIC COMMAND will print the DTE registers.
- 12) The RESET command is useful to clear one internal device at a time to determine if that is the failing area.
- PAR> RESET PI will release the priority interrupt system. If it is holding down the machine it should now continue.

Note 8 After each reset be sure to check the state of the KL by doing a QUIT to be assured it hasn't continued.

PAR> Reset Page releases pageing system
 PAR> Reset DTE releases DTE
 PAR> Reset IO releases I/O system

- 13) Instructions may be executed, but remember, you will not know where the information will go or what the KL may do with it.
- PAR> XCT 700400000005 read ERA
 PAR> EXAM TEN 5 get ERA DATA
 will probably be changing

14) You may deviate from this procedure depending on symptoms you see along the way. However, with this format you can best collect accurate data with minimal chance of destroying the pack.

15) Upon seeing (PAR>) you may also do a shutdown abort on halt command which will, if executed, let you safely mount the KLAD, however, the state of the machine will be changed and most of the useful data lost.

MA2Ø 2-WAY

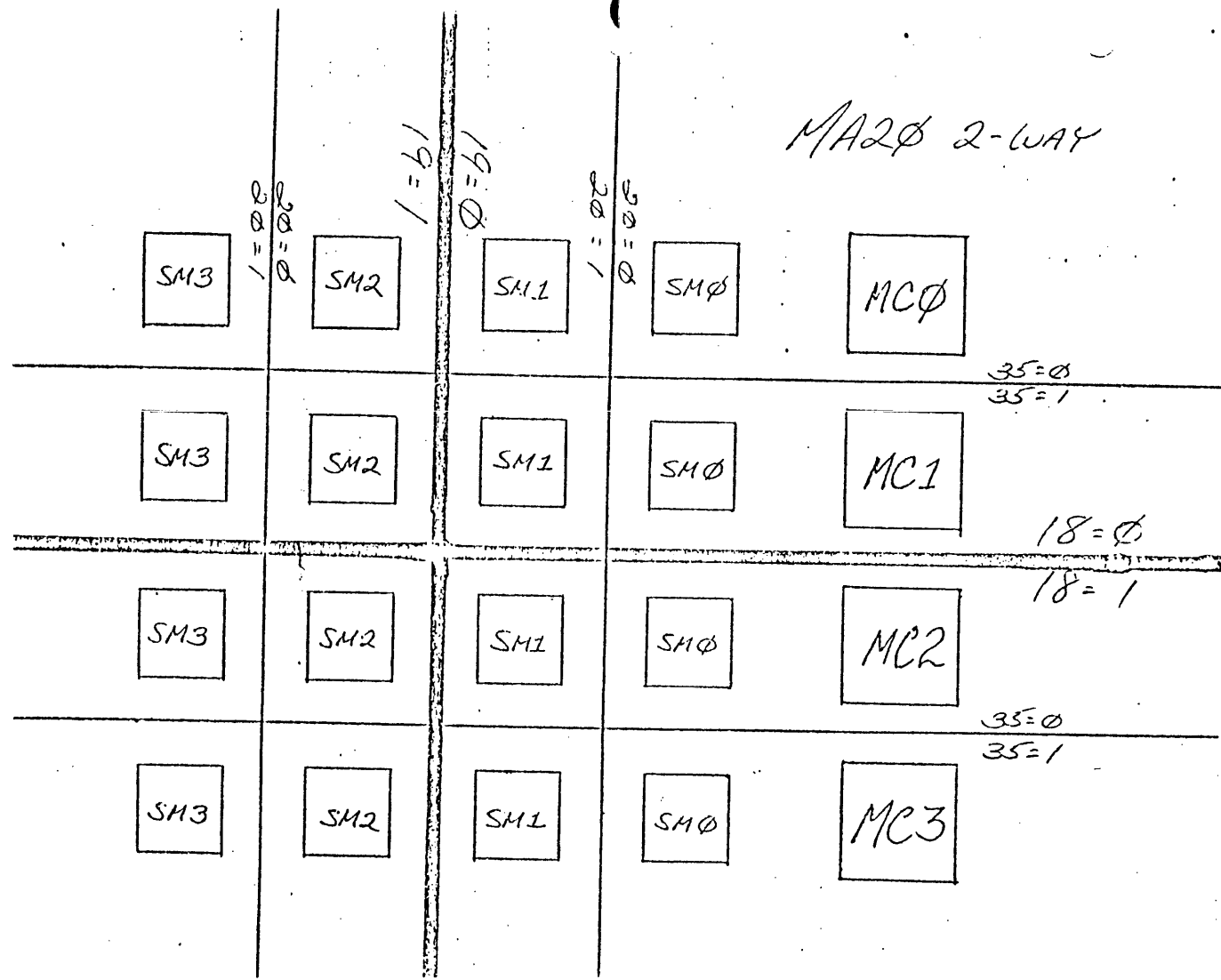

15
19
6

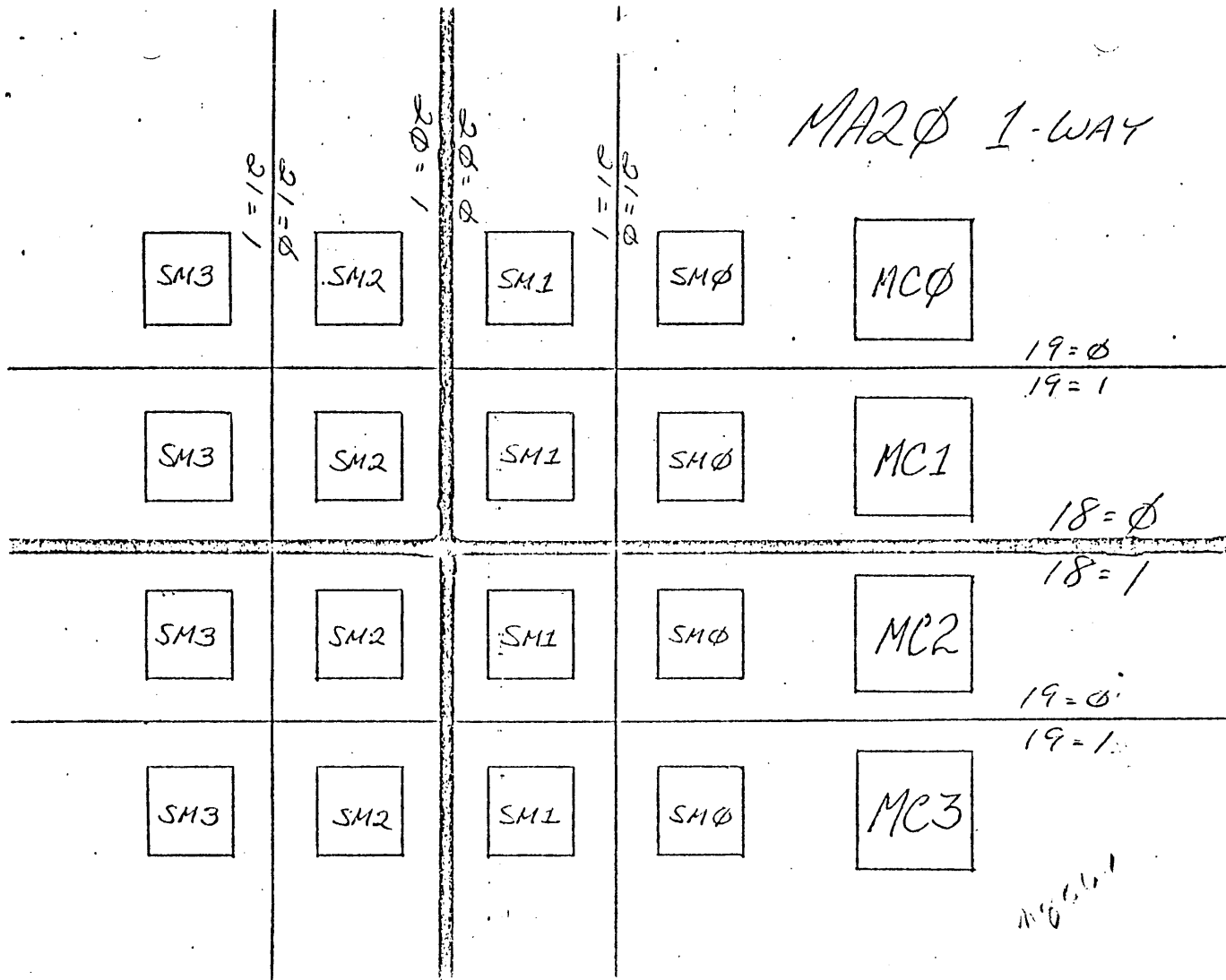

18=Ø
19=1

MB2φ 4-WAY

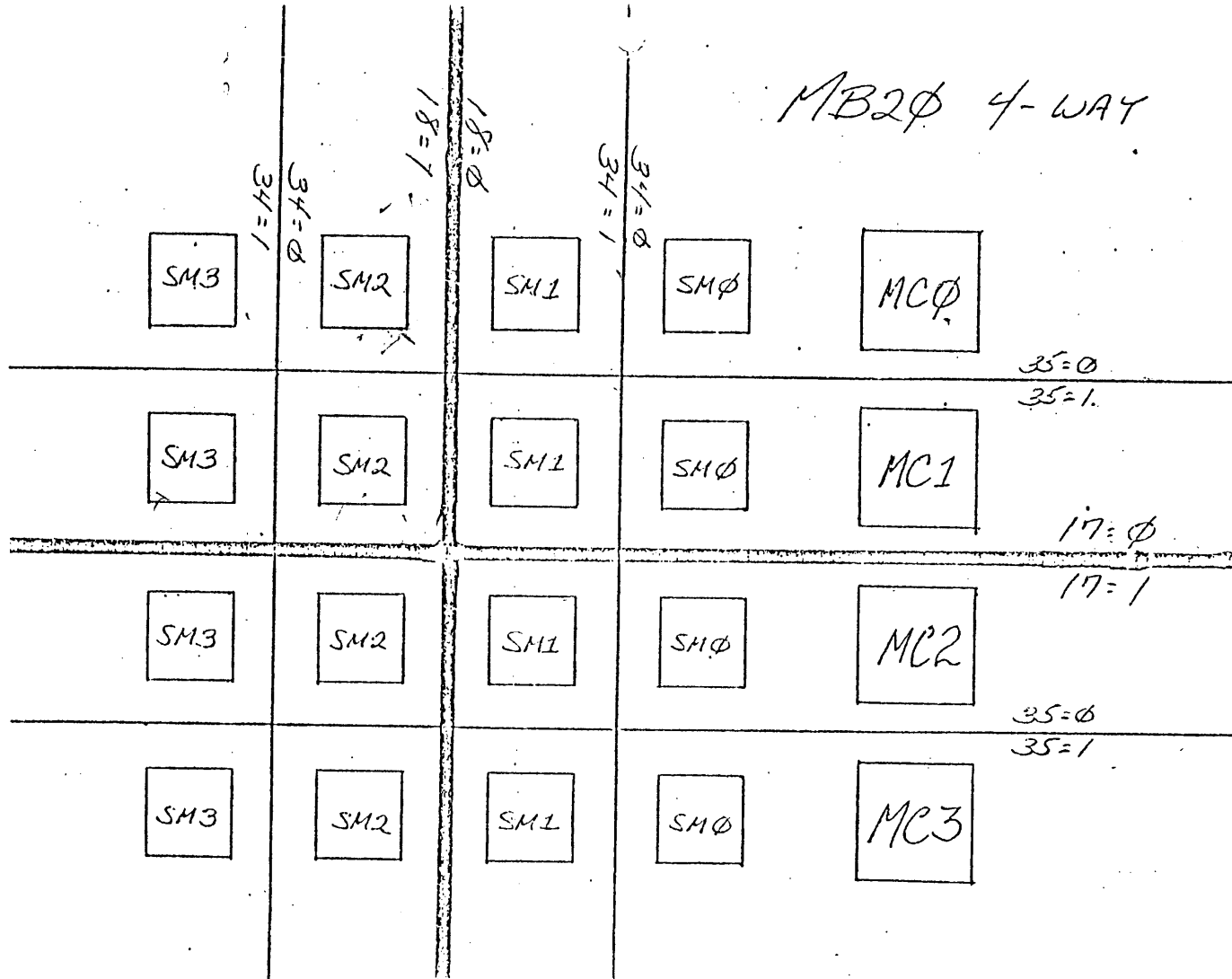

MB2Ø 2-WAY

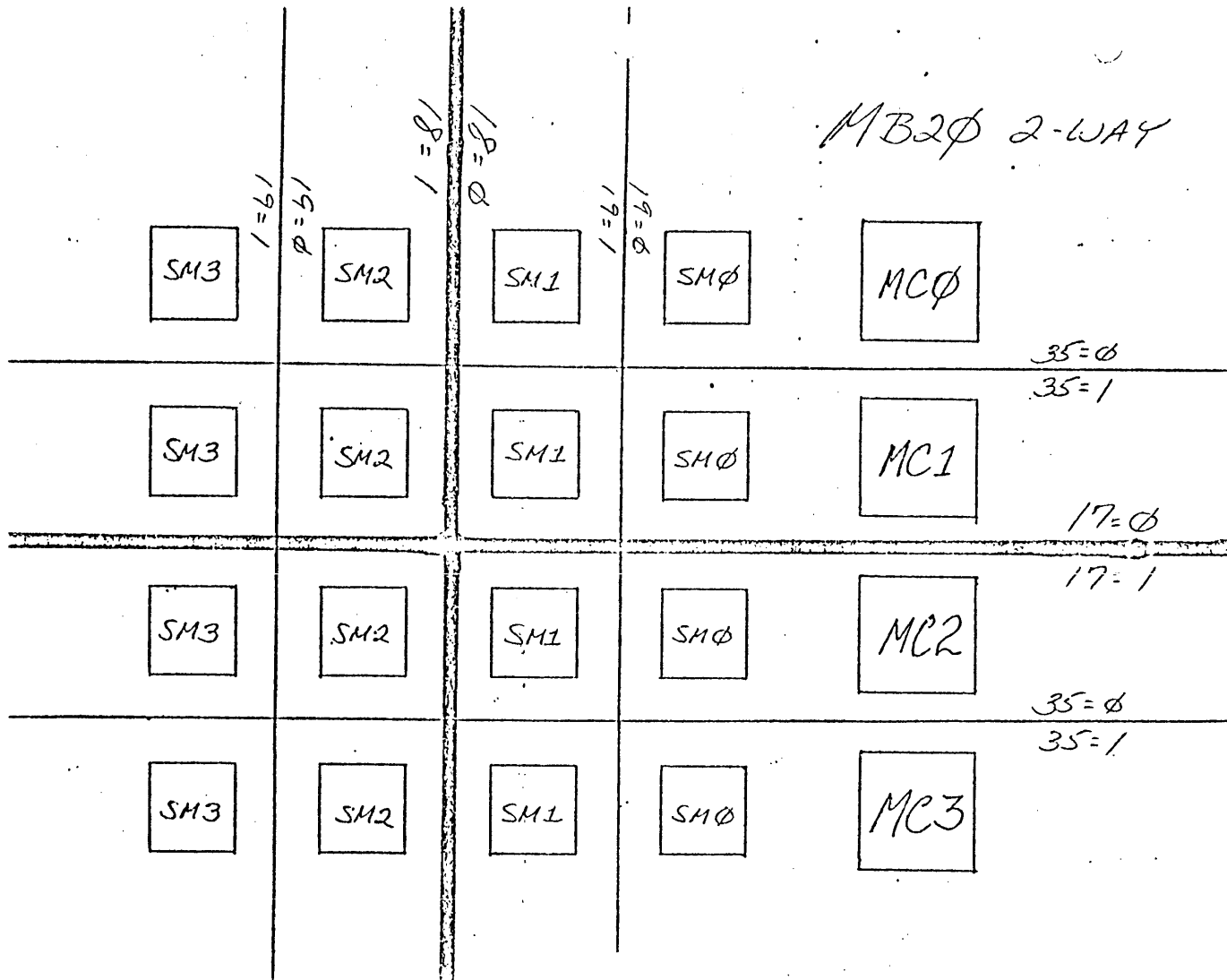

MB2φ 1-WAY

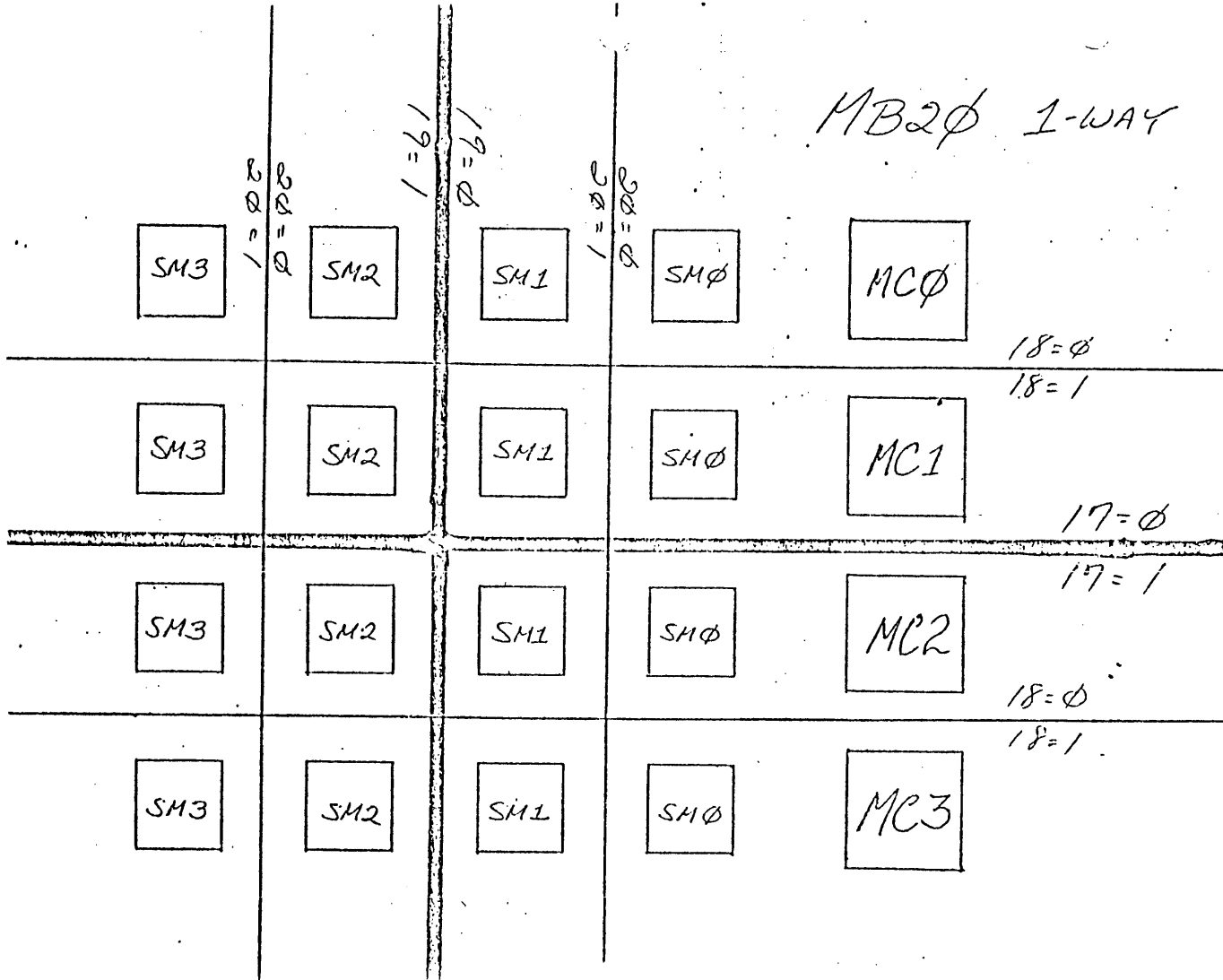

20--MA20--MA20--MA20--MA20--MA20--MA20--MA20--MA20--MA20--MA20--

***** 4WAY INTERLEAVE ***** ***** 2 WAY I/L *****

19-20 34-35 -- BANK -- CONT ----- (128K) ----- BANK -- CONT -----

0	0	0	0	0	0	0
0	1	0	1	0	0	1
0	2	1	0	0	0	0
0	3	1	1	0	0	1

1	0	0	0	1	0	0
1	1	0	1	1	1	1
1	2	1	0	1	0	0
1	3	1	1	1	1	1

2	0	2	0	2	0	0
2	1	2	1	2	1	1
2	2	3	0	2	0	0
2	3	3	1	2	1	1

3	0	2	0	3	0	0
3	1	2	1	3	1	1
3	2	3	0	3	0	0
3	3	3	1	3	1	1

103	30	CLK3 DRAM PAR ERR.	1
104	30	CLK3 CRAM PAR ERR	1
105	30	CLK3 FM PAR ERR	1
106	30	CLK3 FS ERR	1
107	30	CLK3 ERROR	0
110	06	APR1 SBUS ERR IN	1
110	07	APR1 NXM ERR IN	1
110	08	APR1 I/O PF ERR IN	1
110	09	APR1 MB PAR ERR IN	1
110	10	APR2 C DIR P ERR IN	1
110	11	APR2 S ADR P ERR IN	1
110	12	APR2 PWR FAIL IN	1
160	16	MBZ4 CHAN PAR ERR	0
160	25	MBZ3 CHAN NXM ERR	0
161	15	MBZ4 MBOX ADR PAR ERR	0
161	22	MBZ3 MBOX NXM ERR	0
161	24	MBZ4 MBOX SBUS ERR	0
162	15	MBZ4 CHAN ADR PAR ERR	0
162	24	MBZ4 MBOX MB PAR ERR	0
171	01	CRC4 RH20 ERR IN	1
171	02	CRC4 OVN ERR IN	1
171	03	CRC4 SHORT WC ERR	1
171	04	CRC4 LONG WC ERR	1
172	03	CRC3 CRC ERR IN	1
177	22	CSH6 PAGE REFILL ERROR	0

Stop
clk

AR

AR X

Pinity

page fail word
code ²⁵¹ 36

George
Hoyler

14 → 17 = box #

10--MH10--MH10--MH10--MH10--MH10--MH10--MH10--MH10--MH10--MH10--

***** 4WAY INTERLEAVE ***** ***** 2 WAY I/L *****

18-20 34-35 -- BANK -- CONT -- BOX -- (256K) -- BANK -- CONT --

0	0	0	0	0	0	0	0
0	1	0	0	1	0	1	0
0	2	0	1	0	0	0	0
0	3	0	1	1	0	1	1
1	0	0	0	0	0	0	0
1	1	0	0	1	0	1	0
1	2	0	1	0	0	0	0
1	3	0	1	1	0	1	1
2	0	1	0	0	1	0	0
2	1	1	0	1	1	1	1
2	2	1	1	0	1	0	0
2	3	1	1	1	1	1	1
3	0	1	0	0	1	0	0
3	1	1	0	1	1	1	1
3	2	1	1	0	1	0	0
3	3	1	1	1	1	1	1
4	0	2	0	0	2	0	0
4	1	2	0	1	2	1	1
4	2	2	1	0	2	0	0
4	3	2	1	1	2	1	1
5	0	2	0	0	2	0	0
5	1	2	0	1	2	1	1
5	2	2	1	0	2	0	0
5	3	2	1	1	2	1	1
6	0	3	0	0	3	0	0
6	1	3	0	1	3	1	1
6	2	3	1	0	3	0	0
6	3	3	1	1	3	1	1
7	0	3	0	0	3	0	0
7	1	3	0	1	3	1	1
7	2	3	1	0	3	0	0
7	3	3	1	1	3	1	1

Code	Bit Position	Code	Description	Value
103	30	CLK3	DRAM PAR ERR.	1
104	30	CLK3	CRAM PAR ERR	1
105	30	CLK3	PM PAR ERR	1
106	30	CLK3	FS ERR	1
107	30	CLK3	ERROR	0
110	06	APR1	SBUS ERR IN	1
110	07	APR1	NXM ERR IN	1
110	08	APR1	I/O PF ERR IN	1
110	07	APR1	MB PAR ERR IN	1
110	10	APR2	C DIR P ERR IN	1
110	11	APR2	5 ADR P ERR IN	1
110	12	APR2	PWR FAIL IN	1
160	16	MBZ4	CHAN PAR ERR	0
160	25	MBZ3	CHAN NXM ERR	0
161	15	MBZ4	MBOX ADR PAR ERR	0
161	22	MBZ3	MBOX NXM ERR	0
161	24	MBZ4	MBOX SBUS ERR	0
162	15	MBZ4	CHAN ADR PAR ERR	0
162	24	MBZ4	MBOX MB PAR ERR	0
171	01	CRC4	RH20 ERR IN	1
171	02	CRC4	OVN ERR IN	1
171	03	CRC4	SHORT WC ERR	1
171	04	CRC4	LONG WC ERR	1
172	03	CRC3	CRC ERR IN	1
177	22	CSH6	PAGE REFILL ERROR	0

General
INFO P. 38

RD/RS pulse width should be 10ms

This adjustment on the 70mscc is I
sector control module.

ARM10LX DATA WARNING - READ RESTART ADJUSTMENT

1. DO A REPEAT EXAMINE IN THE SECTOR TO BE ADJUSTED.
2. TRIGGER THE SCOPE NEGATIVE ON CHANNEL 1.
3. PUT CHANNEL 1 PROBE ON DATA WARNING SIGNAL (QUICKLATCH PIN A7).
4. PUT CHANNEL 2 PROBE ON RDRS SIGNAL (QUICKLATCH PIN A2)..
5. ADJUST FOR ~~340NS~~ FROM THE LOW GOING EDGE OF CHANNEL 1 TO THE LOW GOING EDGE OF CHANNEL 2 USING THE TOP POT ON THE ASSOCIATED SECTOR CONTROL MODULE. (THE BOTTOM POT IS FOR PULSE WIDTH WHICH SHOULD BE 90NS).

THIS ADJUSTMENT WILL WORK FOR KA'S, KI'S, OR KL'S.

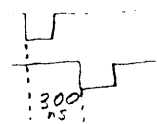

ARM-10LS 280-290 nsec - between low going edges
ARM 10LX 300 msc (leading)

- 1.) Just run a memory diagnostic. (DBMMA 0CMMK,
(May not work in a which case go to step 1,
(DBMMA doesn't need correct memory address.)

Shortcuts — 1.) easiest to get the CPU to RD/WK memory.

2.) Memory box in 4-bus, 4-way interleave, requires scoping ports 4-7.

2.-better) Run memory one sector at a time, in one bus mode — you don't have to move the scope probe this way.)

Read - Rectifier circuit adjustment

- 1) Overload all except 1 sector, and make it light sector
- 2) Take system down to one bus mode (A/F)
- 3) Run OGMMAH
- 4) scope A2 & A7 to see data warning & new pointer signals. (if not working, check the tube)
- 5) adjust the one sector control module.

Pl. 42 Data warning

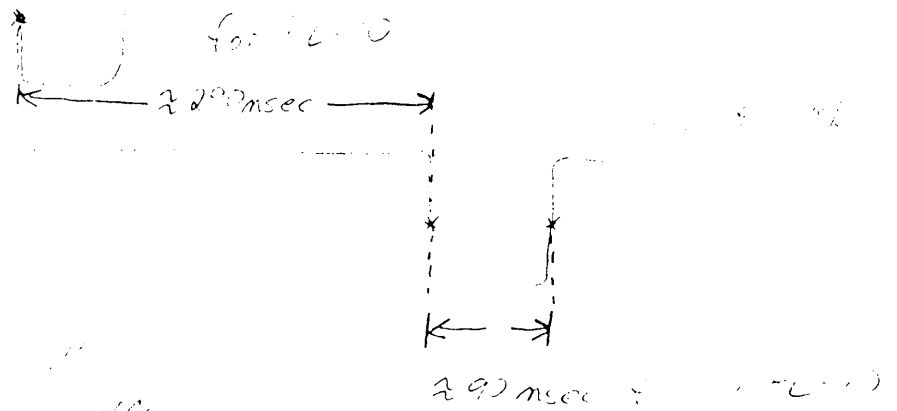

A11 - 2
Sector Control
In adjustment
the top two pots

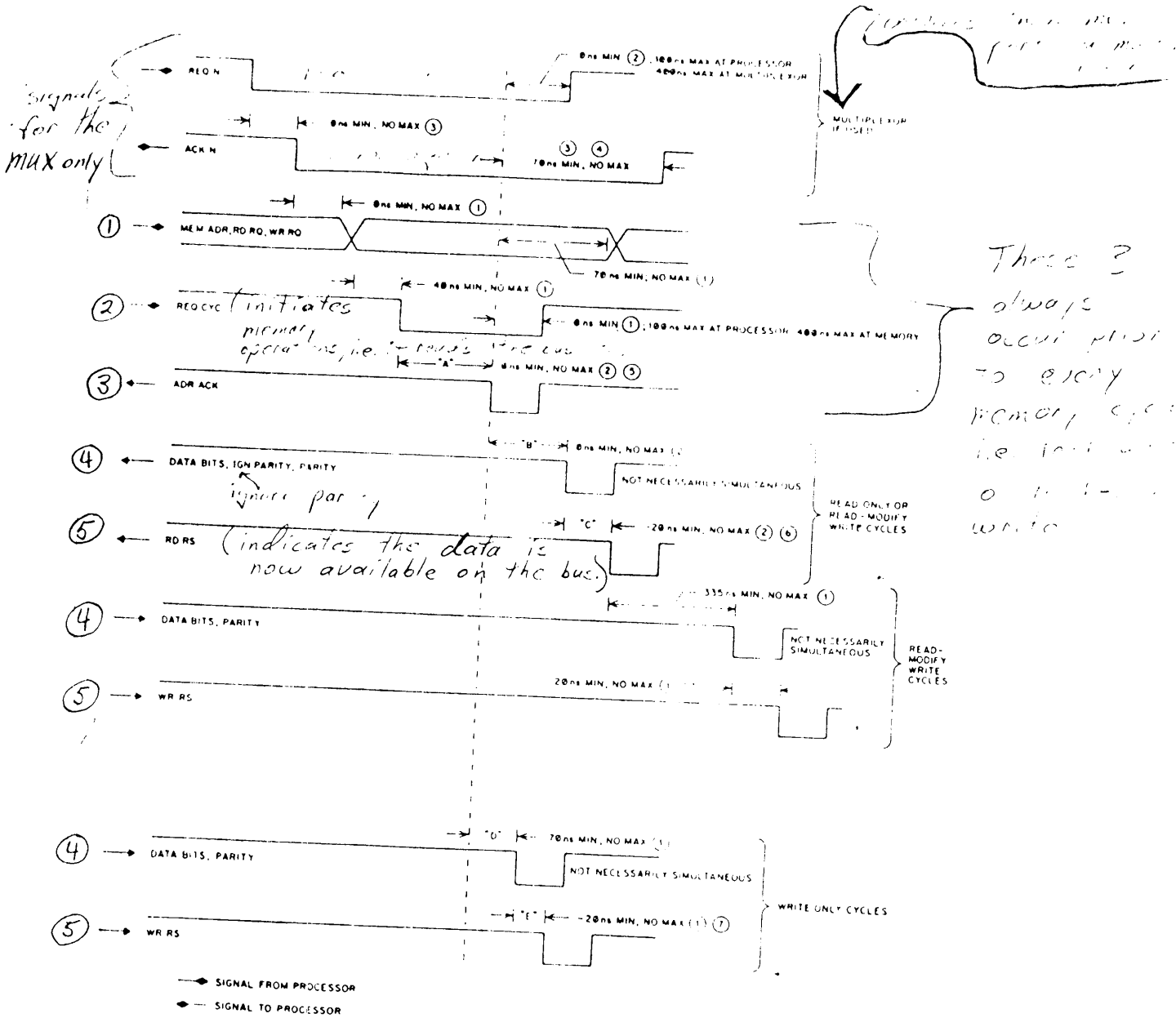

- NOTES:
- ① CONTROLLED BY AND MEASURED AT THE PROCESSOR (CONNECTOR)
 - ② CONTROLLED BY AND MEASURED AT THE MEMORY MODULE (CONNECTOR)
 - ③ CONTROLLED BY AND MEASURED AT THE MEMORY MULTIPLEXOR (PROCESSOR CONNECTOR)
 - ④ ACK N WILL BE TRUE UNTIL THE END OF BUS OPERATION (RD RS IF READ ONLY OR WR RS IF READ-MODIFY-WRITE OR WRITE ONLY)
 - ⑤ CENTRAL PROCESSOR WILL DECIDE IT IS ADDRESSING NON-EXISTANT MEMORY AFTER 100 μs
 - ⑥ RD RS MUST OCCUR NO EARLIER THAN 20ns BEFORE THE LATEST DATA, PARITY OR IGNORE PARITY PULSE.
 - ⑦ WR RS MUST OCCUR NO EARLIER THAN 20ns BEFORE THE LATEST DATA OR PARITY PULSE
- MAXIMUM CABLE LENGTH IS 150ns ONE WAY (30m OR 98 FT @ 67% PROPAGATION FACTOR).
- READ ACCESS IS "A" + "B" + "C"
WRITE ACCESS IS "A" + "D" + "E".
- *NO MAX* IMPLIES THAT THE MEMORY BUS, MEMORY, AND PROCESSOR ARE TIED UP UNTIL EVENT OCCURS

Pin 30 which occurs before memory & whatever can read/write to that memory.

This also occurs before every data transfer

If signal (3), ADDRESS ACKnowledge is not recieved from memory the requesting device does a time out.

Figure 7-3 Memory Bus Timing

and external memory
DMA DESKEW PROCEDURE - Use the model 475 scope

NOTE: Use equal length probes with short grounding clips set up scope as follows:

Time/Div 20NS
Sync: Negative - external
Channel 1: .5V/CM

KL10 can run internal or external memory.

Adjust ground reference for 1.3 volts above center line.

Channel 2: .5V/CM
Adjust ground reference for 1.5 volts below center line.

Inter-

face

the M-box.

Place sync on 4E22F2 'A change coming L'
Place channel 1 on 4D33P1 'mtr clock'
Place channel 2 on 1A02R2 (DMC2 clk deskew point)

(1) (2) (3) (4) (5) (6) (7) (8) (9) (10) (11) (12) (13) (14) (15) (16) (17) (18) (19) (20) (21) (22) (23) (24) (25) (26) (27) (28) (29) (30) (31) (32) (33) (34) (35) (36) (37) (38) (39) (40) (41) (42) (43) (44) (45) (46) (47) (48) (49) (50) (51) (52) (53) (54) (55) (56) (57) (58) (59) (60) (61) (62) (63) (64) (65) (66) (67) (68) (69) (70) (71) (72) (73) (74) (75) (76) (77) (78) (79) (80) (81) (82) (83) (84) (85) (86) (87) (88) (89) (90) (91) (92) (93) (94) (95) (96) (97) (98) (99) (100)

Adjust DL2 (4th delay from top) on 8560 Module in slot 3 until the leading edge of the first clock pulse on channel 2 crosses the center line the same time as the leading edge of the 'A phase clock' tic on channel 1 (fig. 1a, Page 2 or 3)

Adjust DL3 (top delay) until the leading edge of the second clock pulse on channel 2 crosses the center line the same time as the leading edge of the 'B phase clock' tic on channel 1 (fig. 1a, Page 2 or 3)

Move channel 2 probe to 1D03F1 (DTR3 clk 125 NS a H)

Adjust DL1 (bottom delay) until the leading edge of the first clock pulse on channel 2 crosses the center line the same time as the leading edge of the 'A phase clock' tic on channel 1. (fig. 1b, Page 2 or 3)

Move channel 2 probe to 1D03L2 (DTR3 clk 62 NS a H)

Adjust DL4 (2nd delay from top) until the leading edge of the first clock pulse on channel 2 crosses the center line the same time as the leading edge of the 'A phase clock' tic on channel 1. (fig. 1c, Page 2 or 3)

Adjust DL5 (3rd delay from top) until the leading edge of the second clock pulse on channel 2 crosses the center line the same time as the leading edge of the 'B phase clock' tic on channel 2. (fig. 1c, Page 2 or 3)

Stop the machine : > MR ↓
> FX ↓ - state clock

DMA20 DESKEW

NOTE: Use equal length probes with short ground clips

Adjust 8560 slot 03
 -DL Locations_

- DL1 - Bottom Delay
- DL2 - 4th delay from top
- DL3 - Top delay
- DL4 - 2nd delay from top
- DL5 - 3rd delay from top

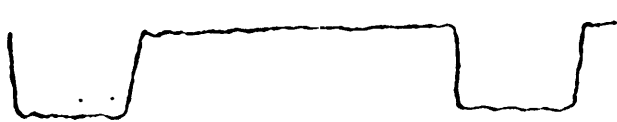

4E22F2 'A CHANGE COMING L'
 (sync)



4D33P1 'MBOX CLOCK'
 (channel A)

FIG. 1A

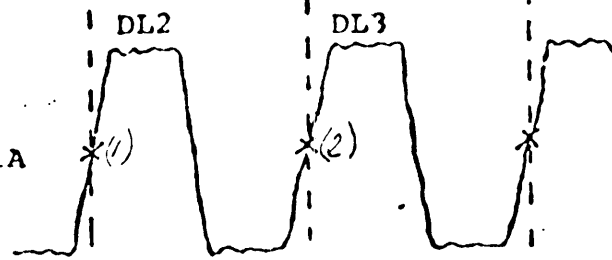

1A02P2 'DMC2 CLK DESKEW POINT'
 (channel B)

FIG. 1B

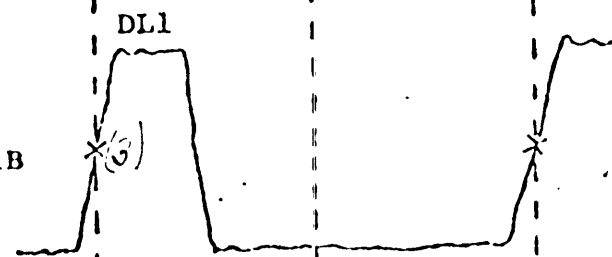

1D03F1 'DTR3 CLK 125 NS A H'
 (channel B)

FIG. 1C



1D03L2 'DTR3 CLK 62 NS A H'
 (channel B)

DMA20 DESKEW

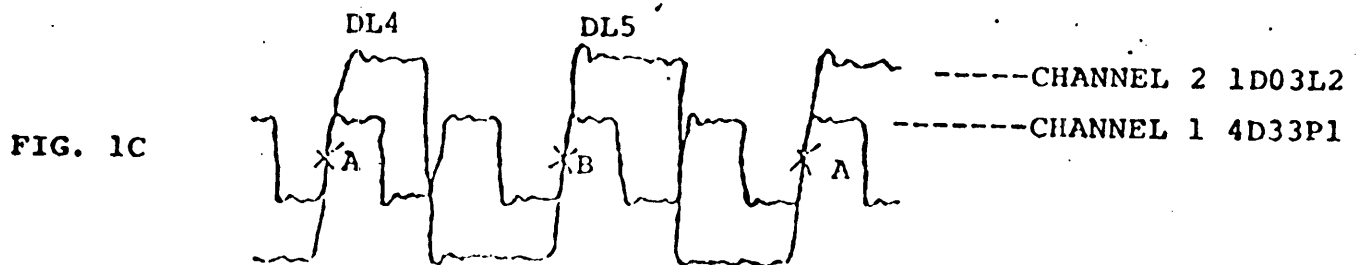
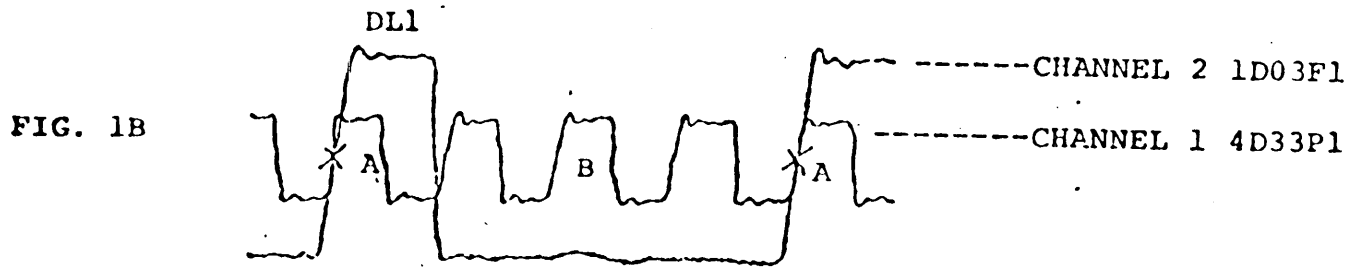
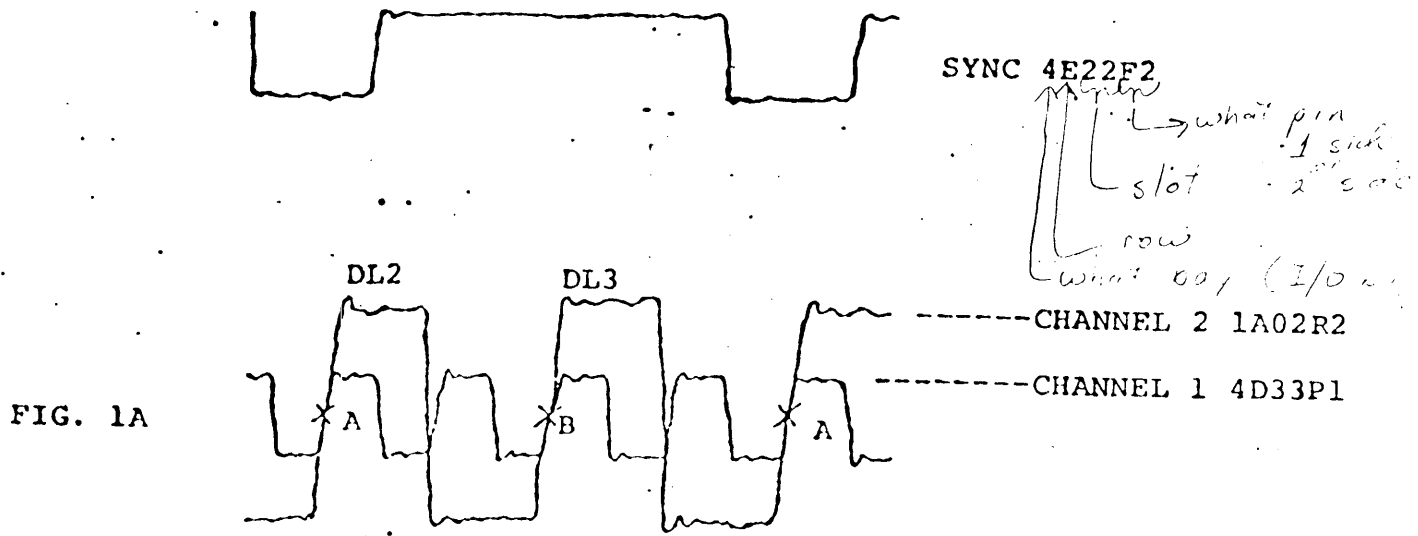

RH20 CLOCK ADJUSTMENT

NOTE: Use equal length probes with short grounding clips
set up scope as follows:

TIME/DIV 20NS

SYNC: POSITIVE-EXTERNAL

CHANNEL 1: .5V/CM

Adjust ground reference for 1.3 volts
above center line.

CHANNEL 2: .5V/CM

Adjust ground reference for 1.9 volts
below center line.

Place sync on 4B9K1 'CH T0 H'

Place channel 1 on 4D33P1 'MBOX CLK H'

Place channel 2 on	RH20/0	1A36D2	'DP4 CLK H'
	RH20/1	1A33D2	" " "
	RH20/2	1A30D2	" " "
	RH20/3	1A27D2	" " "
	RH20/4	1A24D2	" " "
	RH20/5	1A21D2	" " "
	RH20/6	1A18D2	" " "
	RH20/7	1A15D2	" " "

Adjust the pot (RH20/0 top pot, RH20/1 2nd pot etc.)
on the 8559 module so that the leading edge of the
DP4 clk on channel 2 crosses the center line the same
time as the leading edge of the MBOX clk that happens
approximately 10NS before CH T0 clk goes high.
(fig. 1a, Page 5 or 6)

Follow same procedure for each RH20 on the system.

RH20 DESKEW

FIG. 1A

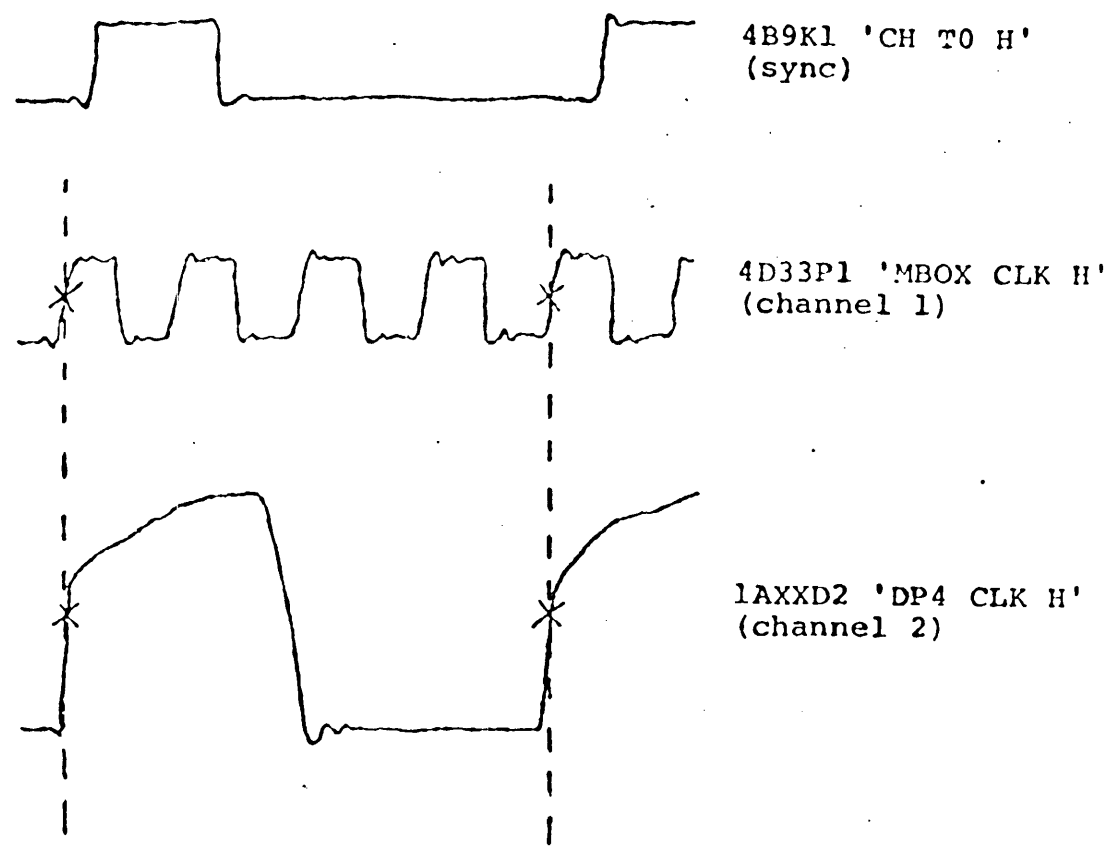

- XX = RH20/0 - 1A36D2
- RH20/1 - 1A33D2
- RH20/2 - 1A30D2
- RH20/3 - 1A27D2
- RH20/4 - 1A24D2
- RH20/5 - 1A21D2
- RH20/6 - 1A18D2
- RH20/7 - 1A15D2

RH20 DESKEW

FIG. 1A

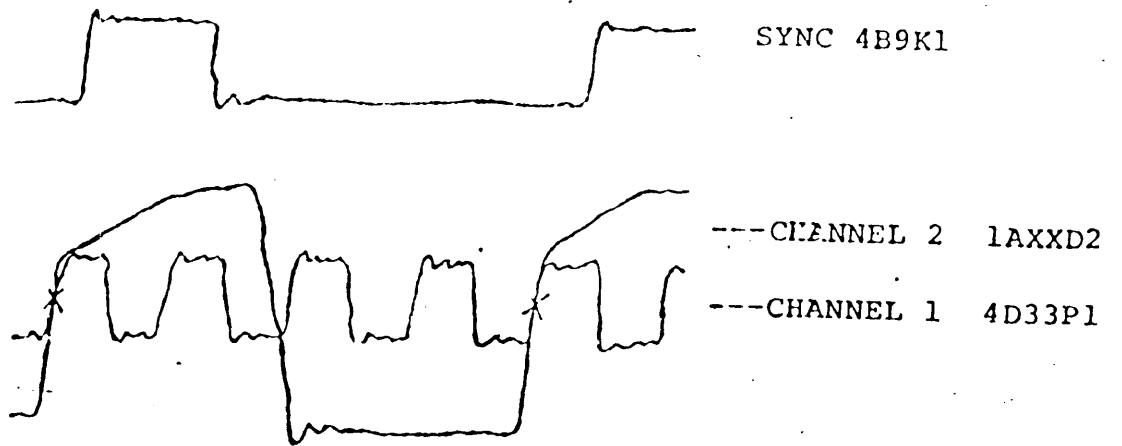

EXTERNAL MEMORY INTERLEAVING

SUPPLEMENT

MEMORY CONFIGURATION ON 10'S
 BY: JAN OSTVANG
 FIELD SERVICE - OSLO, NORWAY

For some reason it might be necessary to configure 10-memories with 2x2K-buses going to two groups of equal size memory. On an S.M.P. system, for example, this is mandatory. However, there are some rules to consider when you do this:

0. I assume that the common rules for interleaving memories are known.
1. THE TWO GROUPS OF MEMORY MUST BE ABSOLUTELY THE SAME AMOUNT OF MEMORY.
2. THE BOX CONTAINING THE LARGEST AMOUNT OF MEMORY (MH10'S, if existing) SHOULD BE ADDRESSED AS LOWEST MEMORY.
3. THE MEMORIES CONNECTED TO K-BUS 0 AND 1 MUST BE ADDRESSED LOWER THAN THE CORRESPONDING MEMORY CONNECTED TO K-BUS 2 AND 3.
4. THE MEMORY TIMING MUST BE SET TO CORRESPOND THE SLOWEST MEMORY IN THE CHAIN.

AS THE EXAMPLE IN FIGURE 1 SHOWS:

- A. Box No. ① must be the lowest address, because:
 - It has K-Bus 0 and 1 .
 - It is greater than ②.
- B. The corresponding box to ① on K-Bus 2 and 3 is ③. This must contain the next addresses.
- C. We have now fulfilled requirements for 4-way interleaving 512K memory, and can start with the next trunk.
- D. The following addresses will be ②, because:
 - Connected to K-Bus 0 and 1.
 - No more MH10's.
- E. The corresponding box to ② will be ④, so this will be the next addresses.

MEMORY CONFIGURATION ON 10'S (cont.)AS THE EXAMPLE IN FIGURE 1 SHOWS:

F. We have now configured all memory like this:

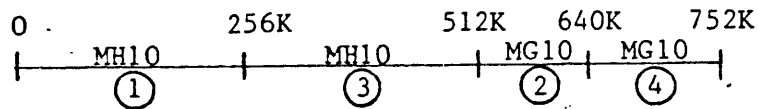

G. Set all interleave switches on, and you have 752K 4-way interleaved memory..

Bit 35 interleaves between controllers and bit 34 between memory boxes, like:

① AND ③ , OR ② AND ④

EXAMPLE IN FIGURE 2:

- A. Box ① and ② are equal size and may be swapped in this configuration. This is also true for boxes ④ and ⑤.
- B. Box ① must be the lowest address because:
 - It has K-Bus 0 and 1.
 - It is the greatest.
- C. The corresponding box to ① (lowest address) is ③, because:
 - It has K-Bus 2 and 3.
 - It is greater than ④ and ⑤.
- D. We have now fulfilled requirements for 4-way interleaving 512K memory, and can start with the next trunk.
- E. The following address will be ②, because:
 - Connected to K-Bus 0 and 1.
 - No more MH10's.
- F. The corresponding memory to ② will be ④ and ⑤ together. It must be the equal size to be interleaved. Therefore, 4 will be the next address and 5 thereafter.

MEMORY CONFIGURATION ON 10'S (cont.)EXAMPLE IN FIGURE 2:

G. We have now configured all memory like this:

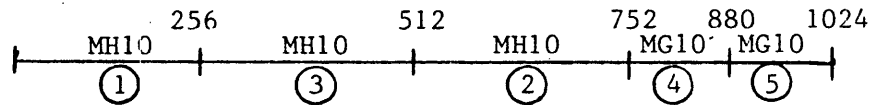

Where it is possible to swap (1) and (2) and/or (4) and (5).

H. Set all interleave switches on, and you have 1024K 4-way interleaved memory.

Bit 35 interleaves between controllers and bit 34 between memory boxes, like;

(1) and (3) OR (2) and (4) + (5)

FIGURES 1 AND 2 ON FOLLOWING
TWO PAGES →

1099

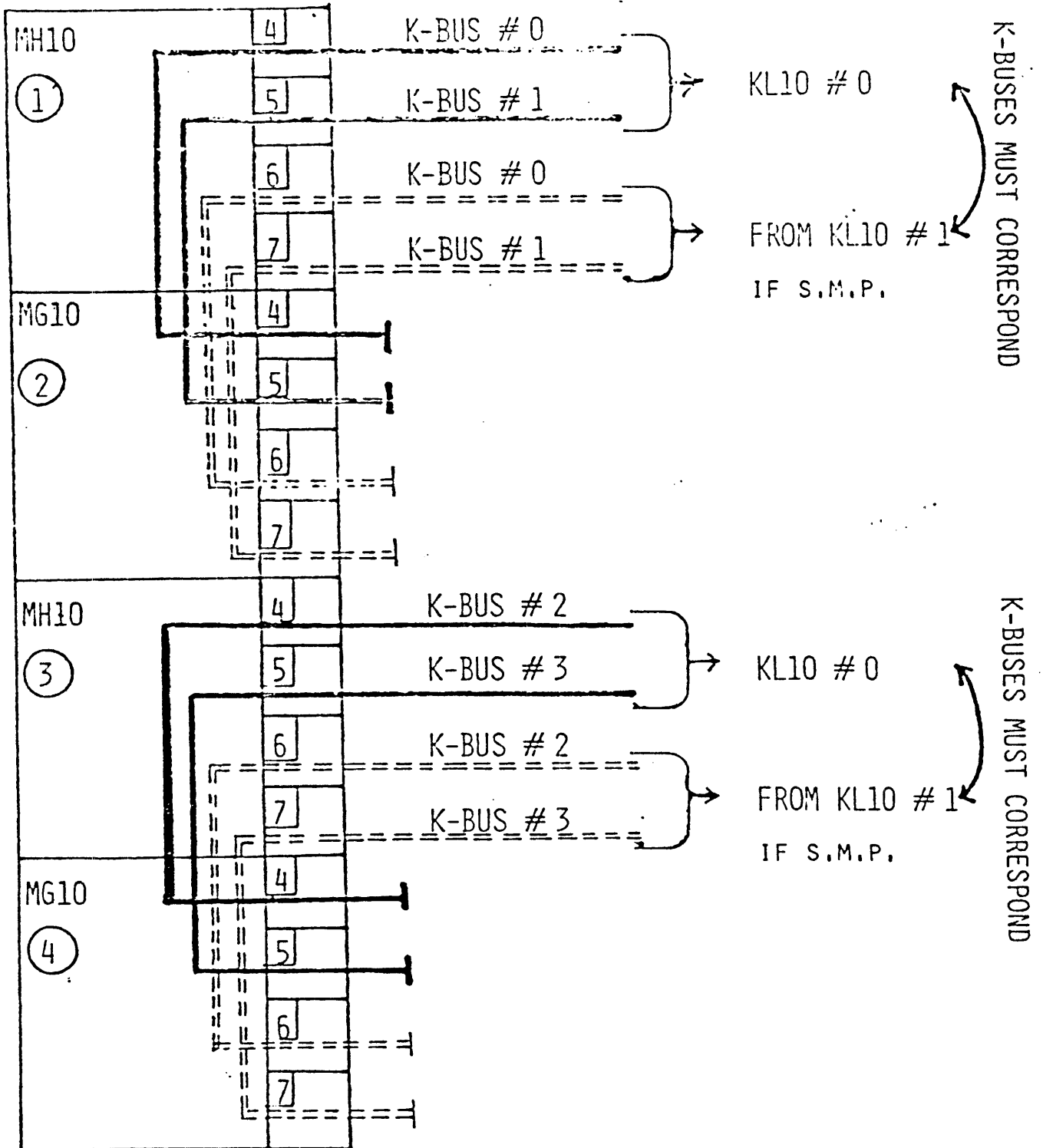

1099

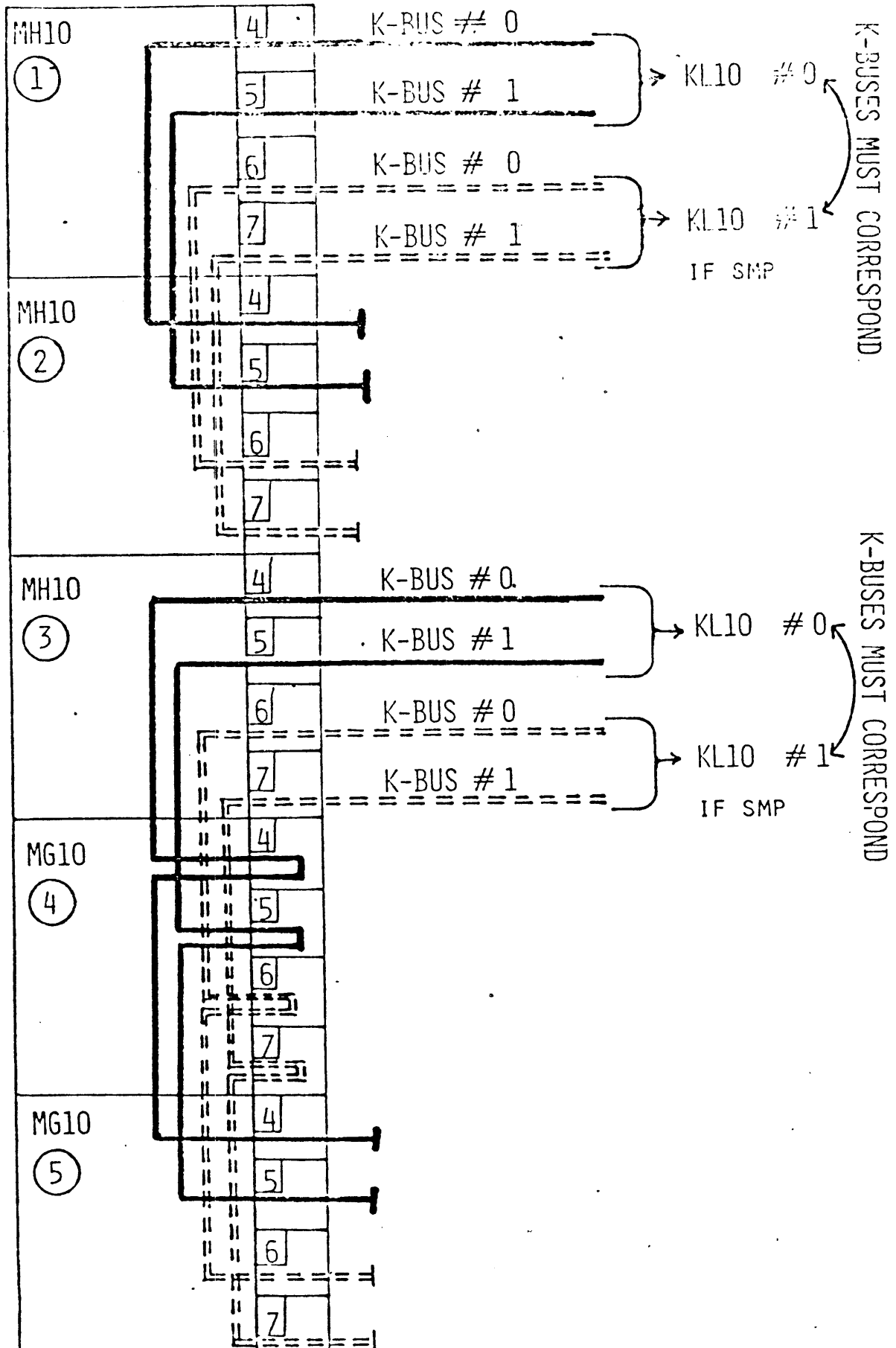

MEMORY INTERLEAVING

The following charts are examples of (non-documented and non-advertised) 4-way interleaving methods with different types of memory boxes.

The two-digit numbers within the memory boxes correspond to the memory switches on the switch panels and the 1's and 0's correspond to the position of the switches (1=up, and 0=down). These examples have been displayed for KI's and KL's.

Cross Reference: KL10-TT-26

MEMORY INTERLEAVING

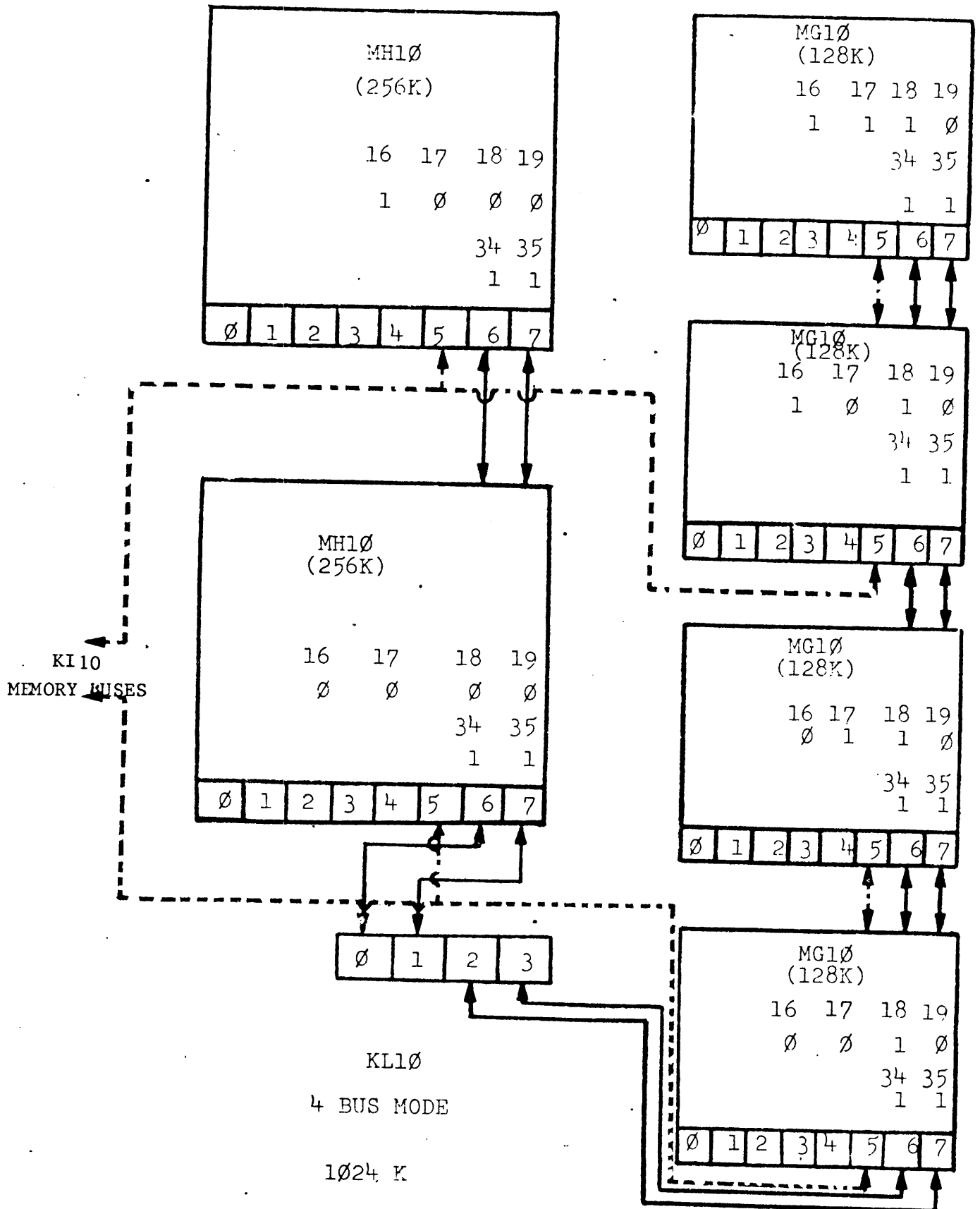

MEMORY INTERLEAVING

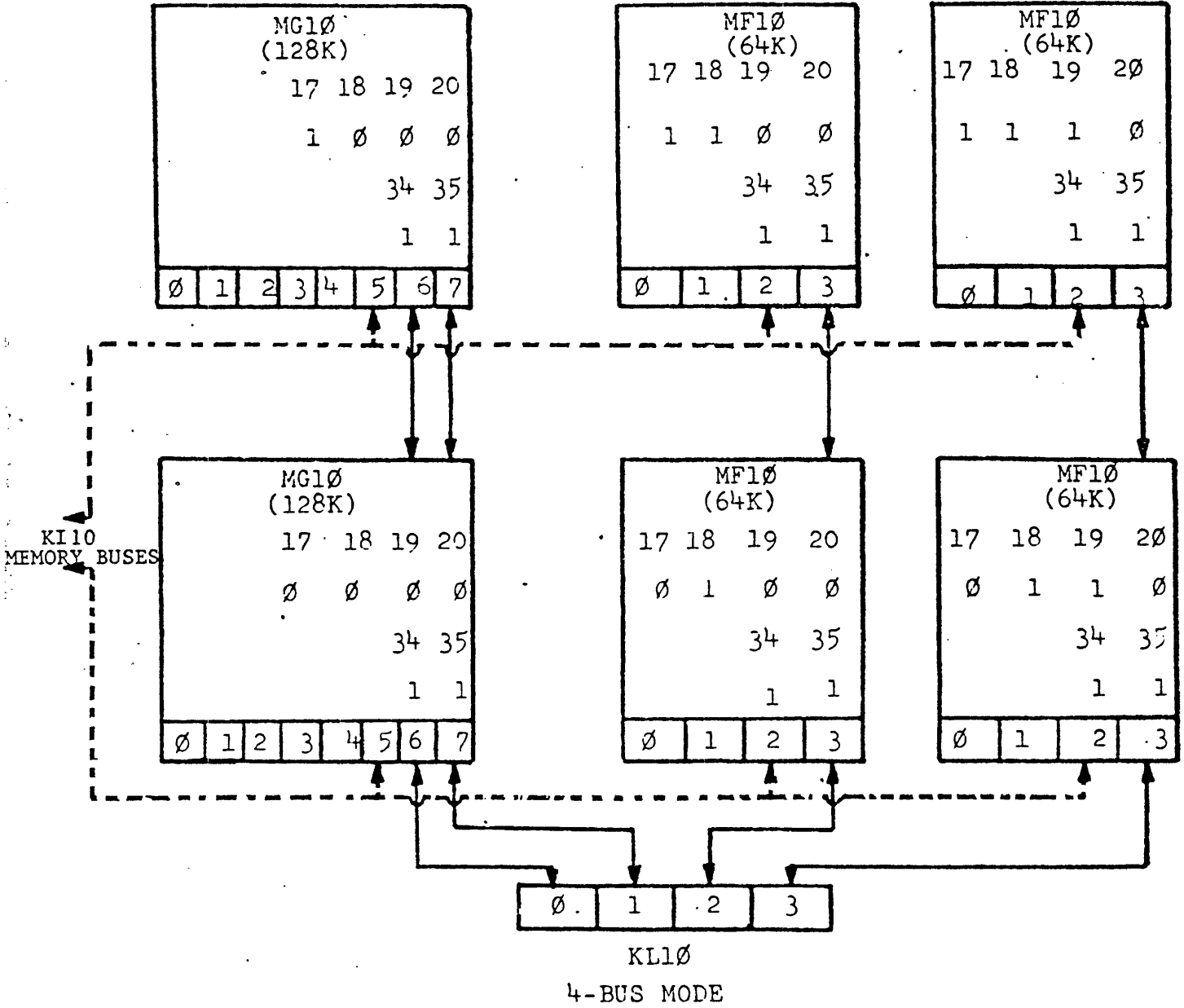

512K

34=0	34=1	18=0	18=1	34=0	34=1	ME 20 4-WAY MCO
SM3	SM2		SM1	SM0	MC0	35=0
SM3	SM2		SM1	SM0	MC1	35=1
SM3	SM2		SM1	SM0	MC2	17=0
SM3	SM2		SM1	SM0	MC3	17=1
						35=0
						35=1

	19=0	19=1	18=0	18=1	19=0	19=1	
	SM3	SM2			SM1	SM0	MB 20 2-WAY MCO
35=0							
35=1	SM3	SM2			SM1	SM0	MC1
17=0							
17=1	SM3	SM2			SM1	SM0	MC2
35=0							
35=1	SM3	SM2			SM1	SM0	MC3

20=0 20=1

19=0 19=1

20=0 20=1

MA 20
2-WAY

SM 3

SM 2

SM 1

SM 0

MC 0

35=0

SM 3

SM 2

SM 1

SM 0

MC 1

35=1

18=0

SM 3

SM 2

SM 1

SM 0

MC 2

18=1

35=0

SM 3

SM 2

SM 1

SM 0

MC 3

35=1

