

# GEM<sup>®</sup> Desktop Publisher<sup>™</sup>

Release 2

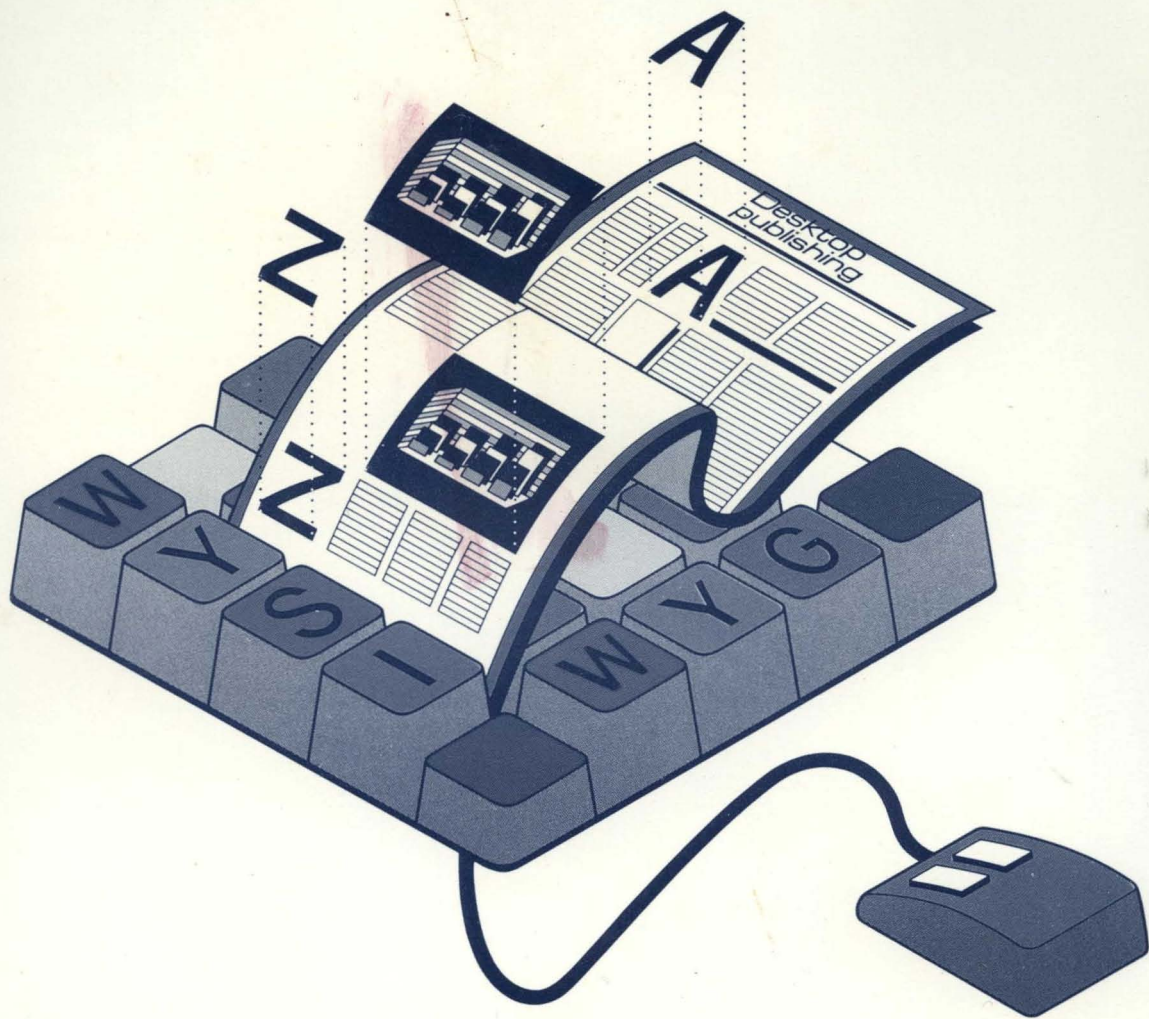

 DIGITAL RESEARCH<sup>®</sup>

# GEM<sup>®</sup> *Desktop Publisher* <sup>TM</sup>

Release 2

## User's Guide

## COPYRIGHT

Copyright © 1988 Digital Research Inc. All rights reserved. No part of this publication may be reproduced, transmitted, transcribed, stored in a retrieval system, or translated into any language or computer language, in any form or by any means, electronic, mechanical, magnetic, optical, chemical, manual, or otherwise, without the prior written permission of Digital Research Inc., 70 Garden Court, Box DRI, Monterey, California 93942.

## DISCLAIMER

DIGITAL RESEARCH INC. MAKES NO REPRESENTATIONS OR WARRANTIES WITH RESPECT TO THE CONTENTS HEREOF AND SPECIFICALLY DISCLAIMS ANY IMPLIED WARRANTIES OF MERCHANTABILITY OR FITNESS FOR ANY PARTICULAR PURPOSE. Further, Digital Research Inc. reserves the right to revise this publication and to make changes from time to time in the content hereof without obligation of Digital Research Inc. to notify any person of such revision or changes.

## NOTICE TO USER

This manual should not be construed as any representation or warranty with respect to the software named herein. Occasionally changes or variations exist in the software that are not reflected in the manual. Generally, if such changes or variations are known to exist and to affect the product significantly, a release note or README.DOC file accompanies the manual and distribution disk(s). In that event, be sure to read the release note or README.DOC file before using the product.

## TRADEMARKS

Digital Research, its logo, and GEM are registered trademarks of Digital Research Inc. GEM Desktop Publisher, GEM Desktop, GEM Draw, GEM Draw Plus, GEM Scan, GEM Paint, GEM WordChart, GEM Graph, GEM 1st Word Plus, GEM Write, and DR DOS are trademarks of Digital Research Inc. 1st Word Plus is a trademark of GST Holdings Ltd. WordStar is a registered trademark and WordStar 2000 is a trademark of MicroPro International. MultiMate is a registered trademark of MultiMate International, an Ashton-Tate company. WordPerfect is a registered trademark of WordPerfect Corporation. IBM, DisplayWrite, and ProPrinter are registered trademarks and Personal System/2, Graphics Printer, and Color Jetprinter are trademarks of International Business Machines Corporation. Microsoft and Microsoft Word are registered trademarks and MS and Microsoft Mouse are trademarks of Microsoft Corporation. XyWrite is a trademark of XyQuest, Inc. Volkswriter is a registered trademark and Volkswriter 3 is a trademark of Lifetree Software. Lotus Manuscript is a trademark of Lotus Development Corporation. PFS: is a registered trademark of Software Publishing Corp. Samna Word is a trademark of SAMNA Corp. Apple and Apple LaserWriter are trademarks of Apple Computer, Inc. Epson is a registered trademark of Epson America, Inc. LaserJet Plus is a trademark of Hewlett-Packard Corp. Xerox is a registered trademark of Xerox Corp. AT&T is a registered trademark of American Telephone and Telegraph. Hercules Graphics Card is a trademark of Hercules Computer Technology. LOGIMOUSE is a registered trademark of Logitech Inc. Manager Mouse is a registered trademark of the Torrington Company. Mouse Systems and PC Mouse are trademarks of Mouse Systems Corp. SummaMouse and SummaGraphics are trademarks of SummaGraphics Corp.

**First Edition: August 1988**  
**Second Printing (Release 2.01)**

All illustrations in this manual were produced with GEM® software:  
GEM® Desktop Publisher™, GEM® Draw Plus™, and GEM® Paint™.

---

# Contents

<b>1</b>	<b>Introducing GEM Desktop Publisher</b>	
	Features . . . . .	1-2
	Word Processor Support . . . . .	1-3
	How to Use This Guide . . . . .	1-4
	Basic Mouse Techniques . . . . .	1-4
	Defaults . . . . .	1-5
	Some Assumptions . . . . .	1-6
<b>2</b>	<b>Disks and Installation</b>	
	Backing Up Your Disks . . . . .	2-1
	Installing the GEM System Software . . . . .	2-2
	Installing Publisher . . . . .	2-3
	After Installation . . . . .	2-4
<b>3</b>	<b>Starting Publisher</b>	
	Starting Publisher from the GEM Desktop . . . . .	3-1
	Starting Publisher from the Command Line . . . . .	3-1
	Starting Publisher Directly to a Document . . . . .	3-2
	"Previous Document" Option . . . . .	3-2
	Double-Clicking on the Document Icon . . . . .	3-3
	Command Line . . . . .	3-4
	What Publisher Remembers . . . . .	3-5
	Publisher Screen . . . . .	3-6
	Menu Bar . . . . .	3-7
	Window . . . . .	3-7
	Work Area . . . . .	3-8
	Base Rectangle . . . . .	3-8
	Title Bar . . . . .	3-9
	Toolkit . . . . .	3-10
	Mouse Form . . . . .	3-13
	Size Box . . . . .	3-14
	Full Box . . . . .	3-14
	Scrolling Points: Arrows, Scroll Bars, and Sliders . . . . .	3-14

## 4 Tutorial

An Important Assumption . . . . .	4-1
Tutorial Document . . . . .	4-2
How the Tutorial Is Organized . . . . .	4-3
Creating a Text File . . . . .	4-4
Starting GEM Desktop Publisher . . . . .	4-5
Bringing Text into Publisher . . . . .	4-6
Formatting Text . . . . .	4-8
Adding Text . . . . .	4-13
Creating and Formatting New Paragraph Styles . . . . .	4-14
Bringing Graphics into Your Document . . . . .	4-18
Adding a Page Number . . . . .	4-20
Saving Your Work . . . . .	4-23
Adding a Second Page . . . . .	4-24
Adding an Image File . . . . .	4-25
Adding Graphics with Publisher . . . . .	4-27
Printing Your Document . . . . .	4-30

## 5 Creating a Style Sheet

Paragraphs . . . . .	5-2
Paragraph Styles . . . . .	5-3
Creating New Paragraph Styles . . . . .	5-4
Setting Paragraph Style Attributes . . . . .	5-5
Assigning Paragraph Styles . . . . .	5-6
Formatting Characters . . . . .	5-7
Formatting Paragraphs . . . . .	5-9
Text Grid . . . . .	5-13
Hyphenation . . . . .	5-15
Formatting Paragraph Tabs . . . . .	5-18
Using Paragraph Tabs . . . . .	5-20
Decimal Tabs . . . . .	5-21
Word Processor Tabs . . . . .	5-22

Saving Style Sheets . . . . .	5-22
Style Codes . . . . .	5-23
Embedding Style Codes in Text Files . . . . .	5-24
Tips on Creating Style Sheets . . . . .	5-25

## 6 Working with Text

Pouring Text into a Rectangle . . . . .	6-1
Text Flow in Rectangles . . . . .	6-2
One Text File, Several Documents . . . . .	6-3
Text Mode . . . . .	6-3
I-Beam and Text Cursor . . . . .	6-4
Placing the Cursor in Your Text . . . . .	6-4
Text Cursor . . . . .	6-4
Marking Text Blocks . . . . .	6-5
Using Publisher to Create New Text Files . . . . .	6-6
Entering Text in Existing Files . . . . .	6-7
Entering Special Characters . . . . .	6-7
Editing Text . . . . .	6-8
Kerning . . . . .	6-10
Hyphenation . . . . .	6-11
Entering Tabs . . . . .	6-12
Text Blocks: Changing Text Style . . . . .	6-12
Text Blocks: Embedded Style Codes . . . . .	6-13
Text Blocks: Changing Fonts, Sizes, and Colors . . . . .	6-14
Cutting, Copying, and Pasting Text . . . . .	6-15
Cutting Text Blocks . . . . .	6-15
Copying Text Blocks . . . . .	6-15
Pasting Text . . . . .	6-16
Bullets and Numbers . . . . .	6-16
Text Rectangle Attributes . . . . .	6-19

## 7 Graphics

Importing Graphics . . . . .	7-1
Bringing Graphics into a Rectangle . . . . .	7-2
Rectangle Attributes . . . . .	7-3
Graphics Elements . . . . .	7-10
Graphics Mode . . . . .	7-10
Fill Attributes . . . . .	7-12
Line Attributes . . . . .	7-12

## 8 Menus

Keyboard Command Equivalents . . . . .	8-1
File Menu . . . . .	8-2
"Abandon/Save" Alert . . . . .	8-5
A Note on Opening Documents . . . . .	8-5
Edit Menu . . . . .	8-6
CLIPBRD Folder . . . . .	8-7
Pasting Rectangles and Graphics Elements . . . . .	8-8
Text . . . . .	8-8
Style Menu . . . . .	8-9
Attributes Menu . . . . .	8-10
Page Menu . . . . .	8-13
Options Menu . . . . .	8-18
PUBLISHR Menu . . . . .	8-28
Desk Accessories and System Memory . . . . .	8-28

## 9 Headers and Footers

Headers as Graphics Files . . . . .	9-1
Page Number Files . . . . .	9-2
Creating Headers . . . . .	9-2
Adding a Header to Your Document . . . . .	9-3
Header Codes . . . . .	9-4
Alternating Headers . . . . .	9-7
Creating Alternating Headers . . . . .	9-7
Putting All Your Headers in One File . . . . .	9-9
Laying Out the First Page . . . . .	9-11
Laying Out the Second Page . . . . .	9-12

## A Word Processor Support

Translating Text . . . . .	A-1
Text File Extensions . . . . .	A-2
How Publisher Treats Unformatted Text . . . . .	A-2
How Publisher Treats Formatted Text . . . . .	A-3
Filters . . . . .	A-3
Using the .ASC Version of a File . . . . .	A-4
Creating Different Versions of a Document . . . . .	A-5
Keyboard Mapping . . . . .	A-5
Default Keyboard Mapping: STANDARD.KYS . . . . .	A-6
Creating Your Own .KYS File . . . . .	A-8
Choosing Keyboard Mapping Files . . . . .	A-10

## B More About Rectangles

Rectangle Layers . . . . .	B-1
Using the Phantom Rectangle . . . . .	B-2
Phantom Rectangles: an Example . . . . .	B-3
Fitting Text to Graphics . . . . .	B-5
"Word too long" Alert . . . . .	B-7



## C Managing Your Files

What Publisher Does for You . . . . .	C-1
Files Encountered in Publisher . . . . .	C-2
Item Selector File Extensions . . . . .	C-3
Mini-Selector File Extensions . . . . .	C-3
.GEM File Extension . . . . .	C-4
Missing Source Files . . . . .	C-5
File Management Tips and Reminders . . . . .	C-6

## D Item Selector and Mini-Selector

Item Selector . . . . .	D-2
Item Selector Components . . . . .	D-2
Directory Line . . . . .	D-3
Directory Window . . . . .	D-3
Changing the Directory Path . . . . .	D-4
Selection Line . . . . .	D-5
Naming and Saving a Document or Style Sheet . . . . .	D-6
Opening a Document; Getting a Style Sheet . . . . .	D-6
Mini-Selector . . . . .	D-7
Mini-Selector Components . . . . .	D-7
Reading Files into Rectangles . . . . .	D-8
Changing File Extension . . . . .	D-8
Changing Path . . . . .	D-9
Creating and Assigning Paragraph Styles . . . . .	D-10
Changing Text Style . . . . .	D-10

---

# Introducing GEM Desktop Publisher

**W**elcome to the world of desktop publishing with GEM® Desktop Publisher™. Now you can compose and print your own illustrated publications—including newsletters, pamphlets, brochures, and catalogs—using just your personal computer and a printer!

Before desktop publishing, you had to combine material and labor from a variety of sources: text from a word processor or phototypesetter, illustrations from the art department, layout by a paste-up artist, and so on. It was expensive and time-consuming.

With GEM Desktop Publisher, *you* are completely in charge. You can make your documents look just the way you want them to, and you have the added luxury of being able to fine-tune and tinker as much as your deadline allows.

## Features

GEM Desktop Publisher offers a host of features that make it possible for you to control the appearance of your documents:

- WYSIWYG** "What you see is what you get." Your screen shows what the final printed page will look like. You don't have to make a giant leap of the imagination from what you see on the screen to what finally appears on paper.
- menu-driven** Publisher's commands are contained in menus, so you don't have to memorize complicated commands or enter them in a command line. To execute a command, you simply choose it from the menu.
- icon-based** The Publisher screen is a pictorial representation of your workspace, and its functions are represented by "icons," pictures you act on directly with the mouse. For example, to switch Publisher into its "Rectangle mode," you click on a picture of a cluster of rectangles.
- text and graphics** Publisher eliminates the need for time-consuming and expensive paste-up by letting you combine text and graphics directly on the screen. Publisher uses text from a wide variety of sources (listed on the next page) and graphics from programs like GEM® Artline™, GEM® Presentation Team™, GEM® Draw Plus™, GEM® Graph™, GEM® WordChart™, GEM® Scan™, and GEM® Paint™. You can also use graphics from other programs that use the .GEM and .IMG file formats.
- style sheets** Style sheets allow you to save the text attributes of your document, including typefaces, type styles, point sizes, paragraph spacing and indents. You can use style sheets over and over, applying them to other documents; you don't have to format each new document from scratch.

## Word Processor Support

Here are some of the word processors and text editors you can use to write the text files you'll use in your GEM Desktop Publisher documents:

- formatted text:
  - GEM® 1st Word Plus™
  - GEM® Write™
  - Microsoft Word®
  - MultiMate®
  - WordPerfect®
  - WordStar® (document mode)
- RFT-DCA format:
  - IBM® DisplayWrite®
  - Lotus Manuscript™
  - Microsoft Word, Version 3
  - PFS:® Professional Write
  - Samna Word™, Version 4
  - Volkswriter 3™
  - WordStar 2000™
- unformatted (ASCII) text:
  - Microsoft Word
  - Volkswriter®
  - WordStar (non-document mode)
  - WordStar 2000
  - XyWrite™

You can even write your text file with Publisher itself.

You can "customize" Publisher so that its text editing keystrokes are the same as those of any of the word processors listed above. For example, if you use WordStar, you can configure Publisher so you can edit text with the same keystrokes you use in WordStar.

Publisher also has a text mode in which you can enter new text, edit existing text, or change the style (boldface, for example) of individual letters and words.

## How to Use This Guide

The next two sections of the *GEM Desktop Publisher User's Guide* describes the installation and startup of Publisher. The tutorial (Section 4) takes you through the creation of a comparatively simple two-page document, with a single illustration on each page. The text file and picture files are provided on your Publisher disks. The tutorial's purpose is to introduce you to some of the basic principles of Publisher, *not* to expose you to all of its features.

The remainder of the guide contains reference material describing Publisher in detail. By using the table of contents and index, you should be able to find anything you want to know in these sections.

## Basic Mouse Techniques

The *GEM®/3 Desktop™ User's Guide* describes in detail how you use the mouse and keyboard with a GEM application. If you have any questions, refer to that book. For the time being, here's a quick refresher on the basic mouse techniques you'll use:

- |                     |                                                                                                                                                                                                               |
|---------------------|---------------------------------------------------------------------------------------------------------------------------------------------------------------------------------------------------------------|
| <b>click</b>        | Press and release the mouse button once.                                                                                                                                                                      |
| <b>Shift-click</b>  | <ol style="list-style-type: none"><li>1. Click on the first item (rectangle, paragraph, or graphic element).</li><li>2. Press and hold down the Shift key.</li><li>3. Click on the remaining items.</li></ol> |
| <b>double-click</b> | Press and release the mouse button twice in rapid succession.                                                                                                                                                 |
| <b>drag</b>         | <ol style="list-style-type: none"><li>1. Press and hold down the mouse button.</li><li>2. Move the mouse.</li><li>3. Release the mouse button.</li></ol>                                                      |

If your mouse has more than one button, always use the button on the *left* for all GEM Desktop Publisher operations.

## Defaults

From time to time this guide refers to Publisher's various "defaults." In case you are not familiar with the term, here's a brief definition.

Simply put, defaults are what a software program does automatically, *without you doing anything*. For example, Publisher has a default font, type style, and point size it uses for text. Publisher also has a default folder (subdirectory) for storing your documents.

In many cases, you can change the defaults. For one thing, you don't have to store your documents in the default folder. Some defaults you can change permanently; others you can change only for the duration of your Publisher work session.

## Some Assumptions

One of the strengths of the GEM software line is the great variety of environments in which it will operate. Unfortunately, it's not possible to write a manual that fully describes every possibility. For that reason, the *GEM Desktop Publisher User's Guide* makes these assumptions:

- It assumes you have a mouse or other supported pointing device. Publisher is much easier to use with a mouse, and if you plan to use GEM applications frequently, you will certainly find a mouse a very worthwhile investment.

If you do not have a mouse, the *GEM/3 Desktop User's Guide* describes how to use the keyboard to do what you would otherwise do with a mouse.

- The guide assumes your hard disk is drive C (identified as **C:** \ in the illustrations). You might have your GEM applications on another drive—drive D, for example. If that is the case, substitute your disk drive identifier for the C identifier used in the guide.
- The guide assumes you are familiar with the basic GEM application techniques and terminology described in the *GEM/3 Desktop User's Guide*.

Happy publishing!

---

# Disks and Installation

**T**his section describes how to prepare your system to run Publisher (backing up the disks, the GEM Setup program, and installing Publisher) and the results of installing the program.

## Backing Up Your Disks

Before you use the disks that came with Publisher, *make a backup copy of each disk*. This ensures that, if anything happens to one copy, you'll still have a usable copy. (See the End User Program License Agreement before copying your disks.)

You can format and copy disks from the GEM Desktop or from the operating system command line; instructions are found in the *GEM/3 Desktop User's Guide* and your operating system user's guide. Briefly, here's what you do:

- First, format as many disks as are in your disk set and label them as copies of your original disks.
- If you have a system with two floppy disk drives, you can back up the disks with the GEM Desktop. With the GEM DESKTOP PUBLISHER MASTER DISK in drive A and the copy disk in drive B, drag the drive A floppy disk icon to the drive B floppy disk icon. When the master disk has been copied, do the same for the GEM DESKTOP PUBLISHER APPLICATION DISK, and the GEM DESKTOP PUBLISHER FONTMERGE UTILITY DISK.
- If you have a system with a single floppy disk drive, use the DISKCOPY command from the command line. DISKCOPY is described in your operating system manual.

After you've backed up your disks, store one set in a safe place away from heat, dust, and magnetism. Use the other set for installing Publisher.



## Installing the GEM System Software

Before you install or use Publisher, you must make sure a set of files called the GEM "system software" has been installed on your computer. The GEM system software is included in the disk set that comes with Publisher.

GEM Setup, the program that installs the GEM system software, is described in your *GEM/3 Desktop Installation Guide*. GEM Setup creates folders (subdirectories) and installs the GEM system software files on your system.

**Note:** The GEM system software is frequently improved to make more features available to you. If you have more than one GEM application, make sure that the *most recent release* of the GEM system software is installed on your computer. The release number appears on the label of the GEM/3 SYSTEM MASTER DISK. You should install the system software from the disk set with the highest release number.

Installing new releases of the system software will not affect your other GEM applications.

Remember, without the GEM system software, you will not be able to install or run Publisher.

## Installing Publisher

Because Publisher can run under a variety of system configurations, you cannot simply insert the master disk and run the program; you must first "install" it. However, the GEM DESKTOP PUBLISHER MASTER DISK includes an installation program that does the work for you.

To install Publisher, do the following:

1. Start the GEM Desktop.
2. Insert the GEM DESKTOP PUBLISHER MASTER DISK (or your back-up copy) into drive A and open the drive A floppy disk icon.
3. Locate the icon called INSTALL.APP.
4. Double-click on the INSTALL.APP icon. This starts the Publisher installation program.
5. Follow the instructions that appear on the screen for installing Publisher on your hard disk.



**INSTALL . APP**

If your system has more than one hard disk, the installation program displays a dialog asking you to identify the disk on which you want Publisher installed.

## After Installation

The installation program places the GEM Desktop Publisher program files in the GEMAPPS folder. It also creates a folder called GEMPAGES inside the GEMAPPS folder. GEMPAGES is Publisher's default folder for saving your documents, although you can save your documents to the folder or folders of your choice.

GEMPAGES itself contains another folder, called PAGENBRS. It contains the page number files used in Publisher.

Finally, the installation creates a folder called FILTERS inside the GEMSYS folder. This folder contains the filter programs that do Publisher's word processor file translations.

The illustration below shows the arrangement of the folders used by Publisher.

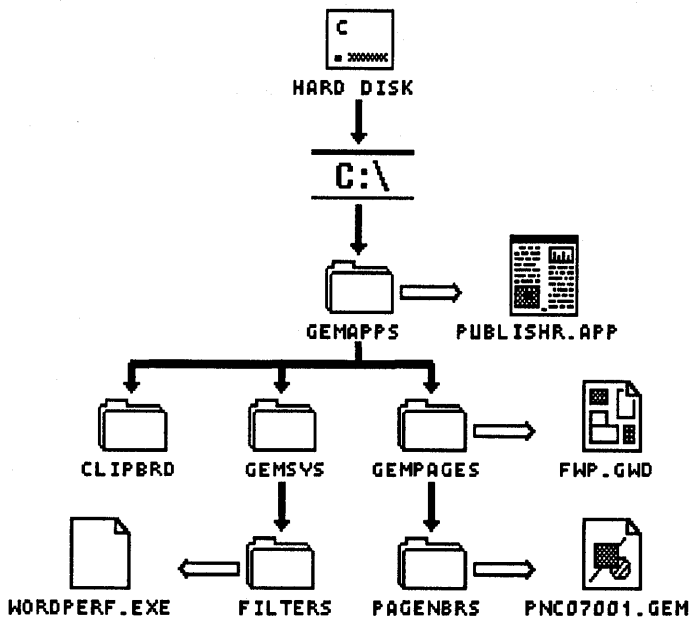

---

# Starting Publisher

**Y**ou can start GEM Desktop Publisher from the GEM Desktop or from the command line. This section tells you how to start Publisher and then describes what you see on the Publisher screen.

## Starting Publisher from the GEM Desktop

To start Publisher from the GEM Desktop:

1. Start the GEM Desktop, as described in your *GEM/3 Desktop User's Guide*.
2. Open the GEMAPPS folder in one of the hard disk's windows.
3. In the GEMAPPS folder's window, find the PUBLISHR.APP icon.
4. To start Publisher, you have two choices:
  - You can double-click on the PUBLISHR.APP icon. This is the fastest method.
  - You can click on the PUBLISHR.APP icon and then choose the Open command from the File Menu.



PUBLISHR.APP

## Starting Publisher from the Command Line

To start Publisher from the command line:

1. Make sure you're in the hard disk's root directory by typing **CD \**.
2. Type **GEM PUBLISHR**.

This command invokes the file PUBLISHR.APP and for that reason uses the shortened spelling.

## Starting Publisher Directly to a Document

What if you want to work on an existing document at the beginning of your Publisher session? You could do it in two steps. First start Publisher and then open the document. Or you could do it in a single step, starting Publisher so that the document appears in the work area from the outset.

Publisher offers three ways of starting directly to a document: the “previous document” option, double-clicking on the document’s icon on the GEM Desktop, or specifying the document’s filename in the command line.

### “Previous Document” Option

The “previous document” option makes it possible for you to start a new Publisher session with the document you were working on when you quit the previous session. Publisher automatically opens the document exactly where you were the last time you saved it.

“Previous document” is one of the options in the Preferences dialog, which Publisher displays when you choose the **Set Preferences** command from the Options Menu. Because this option determines what will be on the screen at the beginning of your *next* Publisher session, you must select it during the current session, and you must then choose the **Save Preferences** command.

**Set Preferences** and **Save Preferences** are described in Section 8.

## Double-Clicking on the Document Icon

This method allows you to start directly to any document, not just the last one you were working on.

Here's how to start directly to a Publisher document from the GEM Desktop:

1. Find the folder containing the document you want. In its default configuration, Publisher saves documents to a folder called GEMPAGES, located inside the GEMAPPS folder.
2. Double-click on the folder containing the document. This opens the folder and displays its directory of icons in the window.
3. Find the icon for the document you want. Each document is represented by two icons, one with the file extension .GWD and the other with the file extension .GMP (see left).



For example, if you called your document NEWSLTTR, the two icons are NEWSLTTR.GWD and NEWSLTTR.GMP. NEWSLTTR.GWD is for use with Publisher; NEWSLTTR.GMP is for use with the GEM Output program.

4. Double-click on the icon with the .GWD file extension. This starts Publisher and brings that document onto the screen.

## Command Line

To start Publisher directly to any document from the command line:

1. Make sure you're in the hard disk's root directory by typing **CD \**.
2. If the document (we'll use NEWSLTTR.GWD as an example) is in the GEMPAGES folder, type this command:

```
GEM PUBLISHR NEWSLTTR
```

Note that, because the document is in Publisher's default folder, you don't need to name GEMPAGES in the command. Nor do you need to enter the .GWD file extension.

3. If the document is *not* in the GEMPAGES folder, you must provide the full path information as part of the command. For example, if the document is in a folder called PAMFLETS, the command takes this form:

```
GEM PUBLISHR C:\PAMFLETS\NEWSLTTR
```

In either case, the command invokes the file PUBLISHR.APP and for that reason uses the shortened spelling.

## What Publisher Remembers

When you open a document, Publisher “remembers” how things were when you last saved the document. When the document is loaded into memory, it brings this information with it:

- style sheet
- page orientation (Portrait/Landscape)
- image size (for example, 8 x 10 or 8 x 13)
- unit of measure of the image (inches/centimeters)
- grid size (the space between grid points)

In addition, the paths for text and graphics files and for saving and opening documents are set to where they were when you saved the document. Finally, the document is opened to the page you were on when you saved it.

Some of these terms might not be meaningful to you yet. They will become meaningful as you use Publisher, and you can also look them up in the index for quick reference.



# Publisher Screen

The illustration below shows the components of the Publisher screen.

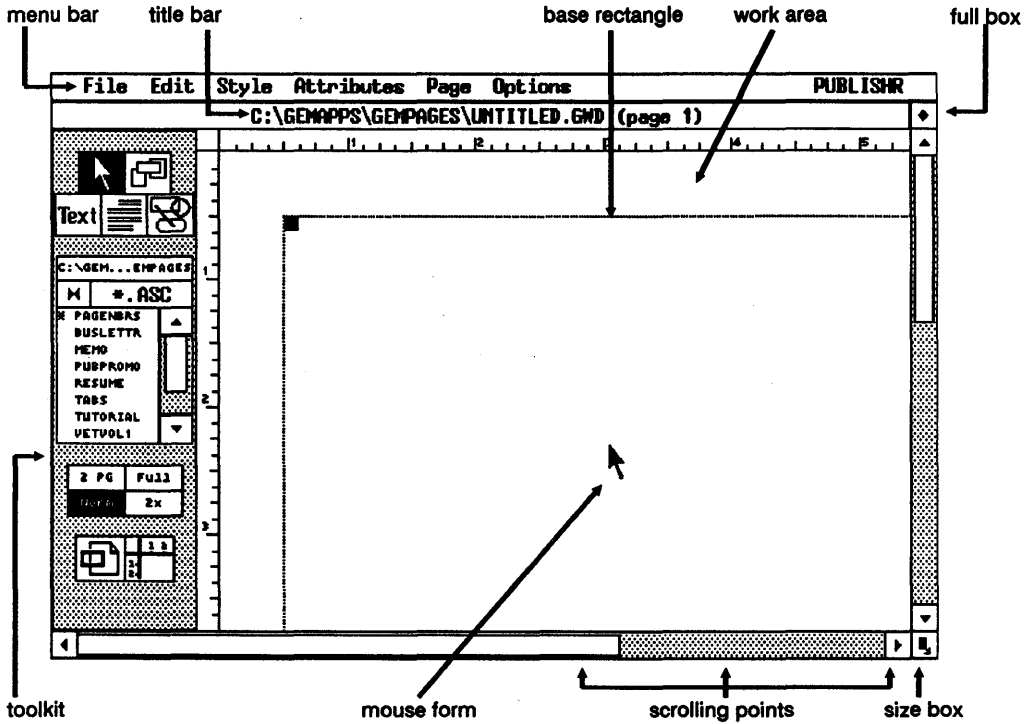

## Menu Bar

The menu bar contains the names of Publisher's menus. The menus work in the same manner as the menus in other GEM applications:

- To display a menu, move the mouse pointer up to the menu's name in the menu bar. If you have your GEM Desktop preferences for menu display set to "click," you must click the mouse button on the menu name in the menu bar.
- To choose a command, click the mouse button when the command name is highlighted in the menu.
- If you display a menu and then decide not to choose a command, move the pointer *outside* the menu and click the mouse button. This causes the menu to disappear from the screen; it does not cause anything else to happen.)

The commands in Publisher's menus are described in Section 8.

## Window

Like many other GEM applications, Publisher creates a "window" on the screen, consisting of the title bar, toolkit, work area, and border (full box, size box, and sliders/scroll bars). You can move the Publisher window and change its size using the components described in the remainder of this section.

## Work Area

The work area is the part of the Publisher window in which you actually compose your document.

You can make changes to the work area with many of the tools described in this section: size box, scroll bars and sliders, page size panel, panner, and ruler switches. In addition, the Page Menu contains many commands that affect the work area in a variety of ways. These commands are described in Section 8.

**Note:** The work area does not necessarily show a full-page view of the document. Depending on your current page view (see the description of the page size panel in the toolkit, later in this section), the work area can show all of the page or only part of it.

## Base Rectangle

Rectangles are the building blocks of Publisher. Rectangles tell Publisher where to put your text or graphics. Every page must have at least one rectangle; without it you can't put anything on the page.

When you start Publisher, the *base rectangle* is already in the work area. The black squares at its corners (called *handles*) indicate that the base rectangle is the "current" (or *selected*) rectangle. A rectangle must be selected before you can insert text or graphics into it, move or size it, or otherwise work with it.

Appendix B describes rectangle *layers*, an important concept for your daily work in Publisher.

## Title Bar

The title bar shows the name and full directory path information for the document currently in the work area. It also tells you what page of the document you're on.

For example, when you start a new document, the title bar reads

**C:\GEMAPPS\GEMPAGES\UNTITLED.GWD (page 1)**

This means you are on page 1 of an as-yet untitled document. It also means that, unless you change the path information, when you name and save the document, it will be stored in the GEMPAGES folder on your hard disk.

If you are working on a document you have named and saved previously, the title bar shows its name, as in the following example:

**C:\GEMAPPS\GEMPAGES\NEWSLTTR.GWD (page 4)**

This title bar tells that you have "opened" (read into your computer's memory) a file called NEWSLTTR.GWD, which is in the GEMPAGES folder of your hard disk. You are currently on page 4 of the document.





The title bar has another function: you can use it to move the window. By placing the pointer anywhere on the title bar and dragging with the mouse, you can move the window to another part of the screen. You can't move the window up into the menu bar or off the left side of the screen.

## Toolkit

The toolkit contains the five mode switches, a mini-selector, the page size panel, panner, and ruler switch.

### Mode Switches

Publisher has five operating modes:

- |           |                                                                                    |                                                                                                        |
|-----------|------------------------------------------------------------------------------------|--------------------------------------------------------------------------------------------------------|
| Select    |   | The mode for selecting, moving, or sizing a rectangle.                                                 |
| Rectangle |   | The mode for creating a new rectangle.                                                                 |
| Text      |   | The mode for entering new text or marking blocks of text for cutting, copying, or changing text style. |
| Paragraph |   | The mode for creating paragraph styles and assigning them to paragraphs.                               |
| Graphics  |  | The mode for drawing filled rectangles, rounded rectangles, circles, and lines in your document.       |

To select a mode, place the pointer on its switch and click the mouse button. You can also switch modes from the keyboard. The keystroke combinations for mode switching are listed in the Icon Shortcuts dialog, displayed when you choose the **Icon Shortcuts** command.

### Mini-Selector

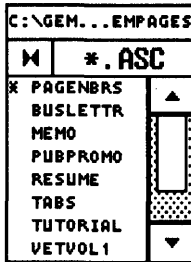

By clicking on a name in the mini-selector, you can choose:

- a text or graphics files to include in your document
- a paragraph style name from the current style sheet
- a text style for a marked text block

The mini-selector is described in detail in Appendix D.

### Page Size Panel

The page size panel contains four "buttons" that you click on to change how much of the document is visible in the window:

2 PG

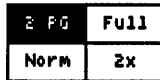

Shows a full-page view of the current page and its facing page. The current page is identified in the title bar. To make the other page current, simply click inside the page.

Full

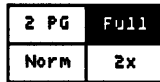

Shows a full-page view of the current page alone.

Norm

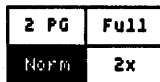

The most accurate view of the placement of text and graphics on the page. One inch on the screen equals one inch in printed output, with slight variations attributable to differences between printers and screens.

2x

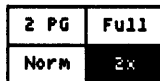

Shows the current page twice as close up as the Norm size.

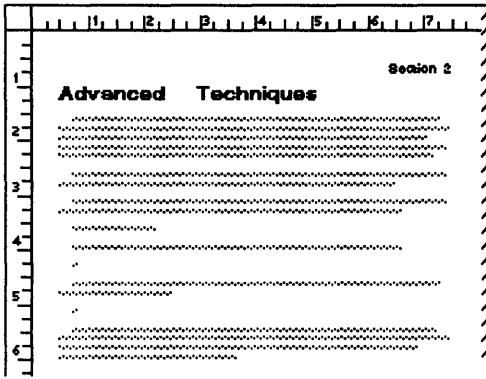

When text is so small it would not be readable, it is "greeked,"—displayed as shaded lines rather than literal characters. Greeked text accurately shows you the layout of your paragraphs, and it has the extra advantage of increasing the program's speed. Greeking is most common in Full and 2 PG views.

### Panner



The panner lets you select part of the page and then move that part into the work area. It is operable only in Norm and 2x sizes.

Here is how to use the panner:

1. Click on the panner icon.  
 Publisher switches the page from its current size (Norm or 2x) to Full. A panning rectangle appears on the page, outlining what was in the work area when you clicked on the panner.
2. Drag the panning rectangle to the part of the page you want in the work area.
3. Release the mouse button. Publisher returns the page to its former size with the selected part of the document now in the work area.

If you click on the panner icon and then decide you don't want to change what's in the work area, simply click on the panner or the panning rectangle.

After you click on the panner icon, all other functions of the program, including the menus, toolkit, and window border, become non-functional. They don't become functional again until you finish dragging the panning rectangle or click on it.

### Ruler Switch



The ruler switch turns the ruler (at the left and top of the page) on and off. To use the ruler switch, simply click on it. When the ruler is turned off, you have a more space available in the work area for your document.

The ruler can measure the page in inches, centimeters, or picas. To set the unit of measure, use the **Rulers in Inches** or **Image Size** command in the Page Menu. These commands are described in Section 8.

The ruler switch is called a “toggle” because—like a toggle switch—it changes something back and forth between two states, like ON/OFF or LEFT/RIGHT.

### Mouse Form

“Mouse form” refers to the symbol that represents where the mouse is on the screen. The mouse form can be a pointer, cross hair, I-beam, or hand, depending on its location and Publisher’s current mode:



The mouse form is always a pointer when it is outside the work area (in the title bar, a menu, scroll bar, or the toolkit). It is also a pointer *inside* the work area when Publisher is in Select mode, Paragraph mode, or Graphics mode. See “Mode Switches” later in this section.



When Publisher is in Rectangle mode, the mouse form becomes a cross hair whenever it is inside the work area.



When Publisher is in Text mode, the mouse form becomes an “I-beam” whenever it is inside the work area. Note that the I-beam and the text cursor are *not* the same thing. See “I-beam and Text Cursor” in Section 6 for a full description of the difference between the two.



The mouse form becomes a hand whenever you are dragging a rectangle in Select mode or Graphics mode.



## Size Box

The size box changes the window's size. By dragging the size box, you can "size down" the window (make it smaller) or make it larger again.

## Full Box

The full box is a toggle. After you size down or move the window, clicking on the full box changes it back to full-screen size. From then on, clicking on the full box switches the window back and forth between full-screen size and the most recent size and/or position.

## Scrolling Points: Arrows, Scroll Bars, and Sliders

The scroll arrows, scroll bars, and sliders allow you to move a different part of your document into the work area.

To move toward the bottom of the document page, you can:

- click on the down-arrow
- click on the part of the scroll bar *below* the slider
- drag the slider toward the down-arrow

To move toward the top of the document page, do exactly the opposite.

You can also scroll horizontally; the principles are the same as for vertical scrolling.

Scrolling is described in detail in the *GEM/3 Desktop User's Guide*.

---

# Tutorial

**T**his tutorial walks you through the creation of a GEM Desktop Publisher document from start to finish. When you're done, you'll see how easy it is to create professional-looking documents and how you have control over the outcome.

The tutorial describes the creation of the two-page newsletter illustrated on the next page. When you are finished, you will be able to print it on a laser printer, dot-matrix printer, or phototypesetter. The Publisher installation program has transferred all the files you need to your hard disk and placed them in the GEMPAGES folder.

You will also create a *style sheet* as part of the tutorial. Style sheets (you'll learn more about them as you work through the tutorial) are one of the most powerful features of GEM Desktop Publisher.

## An Important Assumption

Before you begin the tutorial, please note an important assumption we've had to make in preparing the tutorial. *The tutorial was prepared on the assumption that this is the first time anyone has done the tutorial with this installation of GEM Desktop Publisher.*

If that is not the case—if anyone has done the tutorial before you—there will be files called TUTORIAL.ASC, TUTORDOC.GWD, TUTORDOC.GMP, and TUTSTYLE.STL in the GEMPAGES folder. To do the tutorial properly, you need to restore things to a “first-time” setup, using the GEM Desktop or your operating system to delete these files or (if your predecessor wants to keep them) rename them to something like TUTORIAL.ASX, TUTORDOC.GWX, TUTORDOC.GMX, and TUTSTYLE.STX.

## ARTICHOKE SALES BOOM

The artichoke industry has recently reported a significant increase in the sales of California's favorite vegetable. Despite increasing costs associated with producing artichokes, the volume being consumed continues to increase.

Californians are not the only fans of the gustatory globe, as much of the crop is exported to the Eastern United States as well as to South America. Many varieties of the artichoke also thrive in Europe and Asia. The plant was originally cultivated in California by Italian and Yugoslavian immigrants at the turn of the century.

The first shipment to the East Coast took place in 1907, and traffic has been brisk ever since. Most of the trade is in the fresh vegetable, but a small percentage of the crop is canned.

### Vive la France

The globe, or French artichoke (*Cynara scolymus*), is a member of the family Compositae, having a resemblance to a large thistle. It grows three to four feet tall with large flower heads that resemble a large green pine cone. This is the part eaten, while young and tender.

The conditions necessary for this plant to thrive exist in very few places in the United States. In California, most of the crop comes from a strip of land along the coast between San Francisco and Monterey and stretching a mile or two inland. The cool foggy climate is ideal; artichokes can withstand neither heat nor frost.

Commercially, the globe artichoke is propagated by sprouts at the rate of about 900 plants per acre.

They are usually placed six feet apart in rows six feet apart. Rich, well-drained land, plenty of water, and fertilizer are required for normal growth.

The buds must be cut before they open, lest they become woody. The small, compact buds are usually the more flavorful but tend to be sold locally at roadside stands. Ironically, the greatest demand is for the larger, less tasty buds.



page 1

### An Acquired Taste

The taste for the vegetable is usually acquired through someone else's urgings. The artichoke is beneficial in that it is high in iron, minerals, and iodine. In California, it is eaten primarily in salads or steamed and dipped in butter. In Europe, however, artichokes are also baked, boiled, fried, and stuffed. They make a unique and flavorful appetizer when served hot—whole or in segments—with mayonnaise, butter, or salad dressing, each bract (leaf) pulled off separately and dipped in sauce. The heart is then cut up and eaten, once the hairy "choke" has been removed.

The artichoke has long been valued as a culinary vegetable. The earliest records of its use are in Asia; it then spread to Italy and Southern France. Many different ways to prepare them have flourished over the years. For instance, in Italy, the dried hearts of both the cultivated and wild varieties are used in soup.

### A 'Choke of a Different Color

The Jerusalem artichoke (*Helianthus tuberosus*) is a quite different plant, grown primarily for its tubers. It is not related to the globe-type artichoke at all. It is native to the Eastern United States. Each six- to ten-foot tall plant can bear 30 to 50 potato-like tubers that can be boiled and eaten. They range in color from reddish purple to yellowish white. The tops can be harvested for silage if cut while tender, but this stunts the growth of the tubers. It acquired the name Jerusalem because its foliage resembles that of the sunflower and Jerusalem is a corruption of the Italian word "girasole," which means sunflower.

The Jerusalem artichoke is occasionally grown in home gardens as a vegetable and is often pickled. It enjoyed a brief renaissance during the 1960's "back to the earth" movement. It is now, alas, used principally for livestock feed in the Northwest. It is easy to cultivate, thrives in poor soil, and is not injured by frost. This accounts for the gigantic yields that can be achieved. In temperate climates, they can spread like weeds.

Two different plants and both relatively unknown, that is, until recently. The current sales boom will bring more people than ever to savor the gustatory globe. But the tuber, like the turnip, will probably have few fans and achieve its greatest fame as an object of humor and its greatest shame—being called a weed.

page 2

## How the Tutorial Is Organized

The tutorial describes the steps typically required for creating a document in GEM Desktop Publisher.

**Note:** This is only one possible sequence of steps. In creating your own documents, you might use a different set of steps, or you might vary the order of the steps.

1. Creating a text file.
2. Starting Publisher. Using the base rectangle.
3. Bringing text into Publisher.
4. Formatting Body Text.
5. Creating new paragraph styles.
6. Adding new text with Publisher.
7. Bringing graphics into your document.
8. Adding a page number.
9. Adding a second page.
10. Adding graphics with Publisher.
11. Saving and printing the document.

Each step begins with a section on "Theory", a discussion of what you will be doing in that step. Theory is followed by "Practice," specific instructions for that step of the creation of the tutorial document. (In a couple of cases, Theory and Practice are combined. For example, you won't have to write a text file; we've provided one.)

## Creating a Text File

### Theory & Practice

The basic ingredient in most Publisher documents is text. You can create your text file *before* you start Publisher (you have two options here), or you can use Publisher itself to create the text file.

One option is to write your text file with one of the supported word processors. This creates a *formatted* (non-ASCII) file. When you bring this file into Publisher, an ASCII copy of the file is made, which preserves most of the text attributes (like boldface or italic text) in the original file. Publisher's word processor file conversion is described in greater detail in Appendix A.

Your second option is to write the file directly in ASCII format, using a word processor or text editor. Although you can't set text attributes in ASCII files, you can insert Publisher's own codes for text styles and other attributes into the file. These codes are described in Section 6.

When using either of these methods to create the text file, you can insert paragraph style names directly into your word processor file. This can save you a great deal of time in formatting your document.

Finally, you can write the text file with Publisher itself. The program includes a simple text editor (it does text entry and edit, as well as cut and paste) that is suitable for single-page documents or for short text files to insert into existing documents.

You don't need to write a text file to do the tutorial. The text file for the tutorial is called TUTORIAL.TXT, and it is in the GEMPAGES folder on your hard disk.

## Starting GEM Desktop Publisher

### Theory & Practice

Section 2 describes how you start GEM Desktop Publisher. Briefly, here are the steps to take:

1. Start your computer.
2. From the operating system command line, type **GEM**. This starts the GEM Desktop.
3. When the GEM Desktop appears on your screen, open the GEMAPPS folder icon.
4. Inside the GEMAPPS window, find the icon labeled PUBLISHR.APP. Double-click on this icon to start Publisher.



When Publisher comes up on your screen, it looks like this:

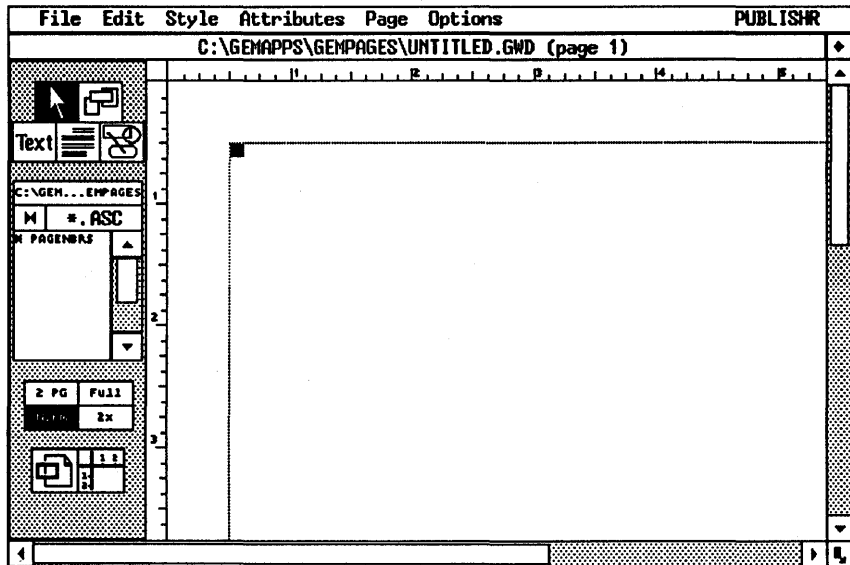

## Bringing Text into Publisher

### Theory

To insert your text file into the base rectangle, you click on the name of your text file in the mini-selector window. Publisher first makes an ASCII copy of the file (with the extension .ASC), then makes a temporary *workfile* in your computer's memory, and finally reads the workfile into the base rectangle.

All your work takes place in the temporary workfile. The .ASC file isn't changed until you save your document, and Publisher never touches your original text file.

### Practice

The text file you will "pour" into the base rectangle is called TUTORIAL.TXT. To bring it into the base rectangle:

1. Make sure the base rectangle is selected, as indicated by the handles at its corners. If it isn't, switch to Select mode and click inside the rectangle to select it.
2. Look at the mini-selector. Its path should read C:\GEM...EMPAGES. If it doesn't, change the path as described under "Changing Path" in Appendix D.
3. Click on the mini-selector's file extension indicator (it says \* .ASC when Publisher starts) until it reads \* .TXT.
4. Find the filename TUTORIAL in the mini-selector window. You might have to scroll the window to find the filename.

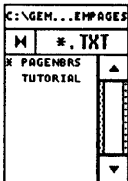

- Click on the filename TUTORIAL in the mini-selector window. Publisher displays a message that it is creating the temporary workfile and then displays the text in the base rectangle.

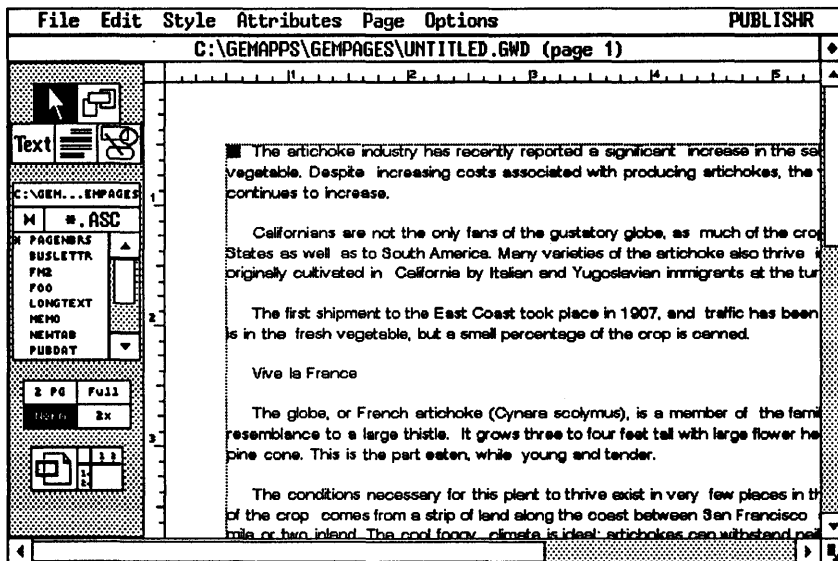



## Formatting Text

### Theory

When you format your text in Publisher, you create a *style sheet*, a special file in which you store the document's text attributes: fonts, styles, and point sizes, plus indents, spacing, and alignments. A style sheet is like a specification you send to a typesetter. In desktop publishing, style sheets offer a great advantage: you can use them over and over, which means you don't have to format each new document from scratch.

This is some of the information you'll store in the tutorial style sheet:

Body Text	justified 14-point Dutch type inch
TITLE	36-point Dutch Bold, centered in the rectangle
HEADING	20-point Swiss Bold, left-aligned

Style sheets are made up of *paragraph styles*. The tutorial style sheet will have three paragraph styles: Body Text (all documents have a Body Text paragraph style), TITLE, and HEADING. Each paragraph style has four attributes: character, paragraph, hyphenation, and paragraph tabs.

Character attributes are font (typeface), style (like Bold or Italic), point size, and color—how the type itself looks.

Paragraph attributes include indents, spacing between lines and paragraphs, and alignment (like ragged right or justified)—how the overall paragraph looks.

The hyphenation attribute determines whether the paragraph style uses hyphenation and, if so, what language's hyphenation rules are followed. Publisher supports hyphenation in eight different languages.

Paragraph tabs allow you to set as many as sixteen tab stops for each paragraph style, with each stop left-aligned, right-aligned, centered, or decimally aligned.

Typically, you create your style sheet in Publisher, often by a process of experimentation. For example, you might try out several different fonts, styles, or point sizes on a given paragraph style. Once you have what you want, you save the style sheet file.

## Practice

In this tutorial, you will format only the Character and Paragraph attributes of each paragraph style. (The other attributes are described in detail in Section 6, "Creating a Style Sheet.") In this step you'll format the Body Text paragraph style. In the next step you'll create two additional paragraph styles and format them.

First, click on "Norm" in the page size panel below the mini-selector (if it is not highlighted already). This setting gives you the best view of the text on the page.

Right now, all the text in your document looks the same; you can't tell headings from body text. Formatting your text will set them apart.

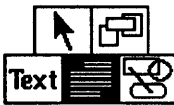

Switch to Paragraph mode by clicking on its icon in the toolkit. You'll notice that the mini-selector lists only one paragraph style, Body Text. That's why everything looks the same.

To set the Character attributes of Body Text, click on any of the paragraphs in the work area, display the Attributes Menu and choose the Character command.

The current settings for Body Text are the Swiss font in 10-point size, Normal (also known as *Roman*) style, and Black color. Make these changes in the Character dialog:

- Click on "Dutch" in the Fonts list.
- Press Esc to clear the "Custom size" field. Type **14** to change the type size to 14-point.

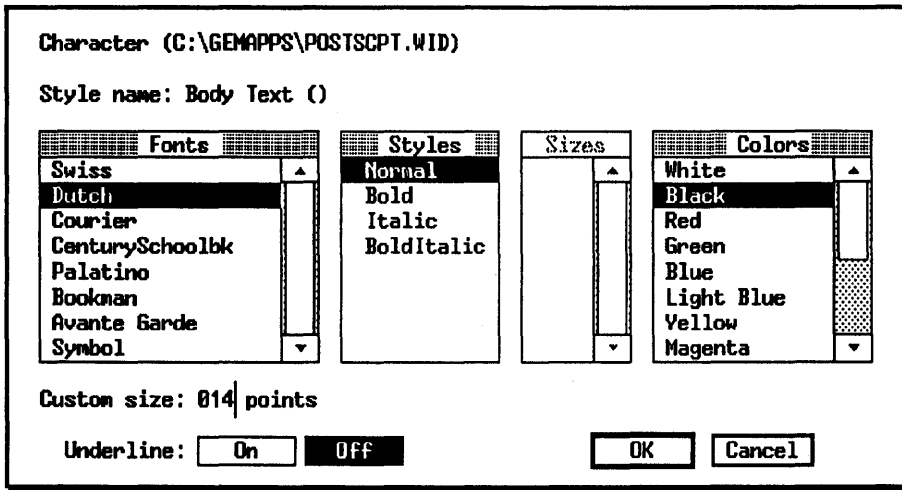

Press the Enter key or click on the OK button to exit the dialog.

Now display the Attributes Menu and choose the **Paragraph** command. Make these changes in the Paragraph dialog:

- Set the First Line Indent and Space Above to zero. To set a field to zero, click the mouse in it and press the Esc key. Publisher converts an empty field to a zero value.
- Click on Line Space, press the Esc key, and type .03.
- Click on Space Below, press the Esc key, and type .1.
- Click on the Justified alignment button and the text grid Off button.

Paragraph		(Units = inches)		
Style name: Body Text ()				
Left Indent: 00.000	Line Space: .03_			
Right Indent: 00.000	Space Above: __. __			
First Line Indent: __. __	Space Below: .1 _			
Tracking: 000.00 %				
Alignment:	<input type="button" value="Left"/>	<input type="button" value="Right"/>	<input type="button" value="Center"/>	<input checked="" type="button" value="Justified"/>
Text grid:	<input type="button" value="On"/>	<input checked="" type="button" value="Off"/>		
Ignore Space Above:	<input checked="" type="button" value="On"/>	<input type="button" value="Off"/>	<input type="button" value="OK"/>	<input type="button" value="Cancel"/>

Press the Enter key or click on the OK button to exit the dialog.

When you exit the dialog, the text on the screen looks like this:

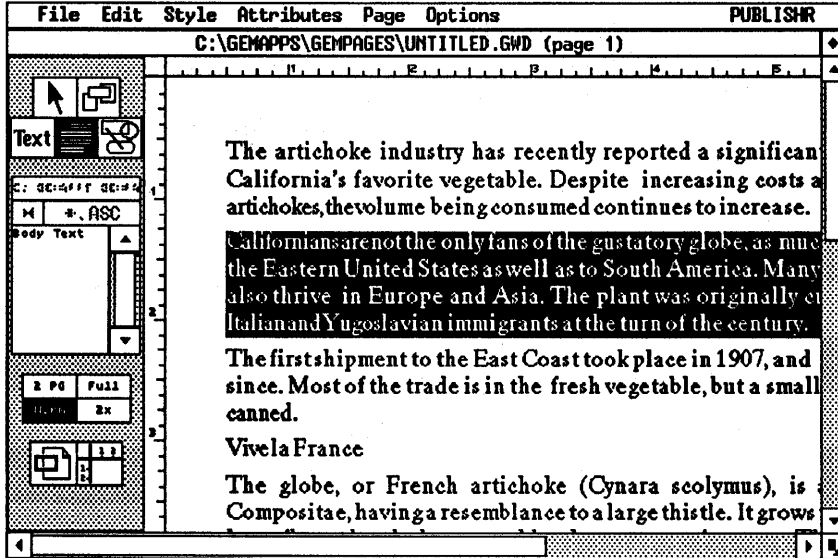

## Adding Text

### Theory

Publisher includes a simple text editor with which you can create new text files or edit the text in your rectangle. You can type text into a file (as you'll do in a moment), and you can cut and paste text within your document and between documents.

If you compare the text on your screen with the finished document illustrated at the beginning of this section, you'll see that we deliberately left out the title text. To add a title, you must use Publisher's Text mode.

### Practice

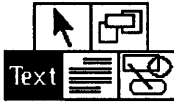

To switch to Text mode, click on the Text mode icon in the toolkit. Note that the pointer becomes an "I-beam" when it is in the work area. You use the I-beam to locate the text cursor on the page.

Position the I-beam before the first character of your text and click the mouse button. A blinking cursor appears. Type **ARTICHOKE SALES BOOM** and press the Enter key. If you make any typing errors, use the Backspace key to correct them.

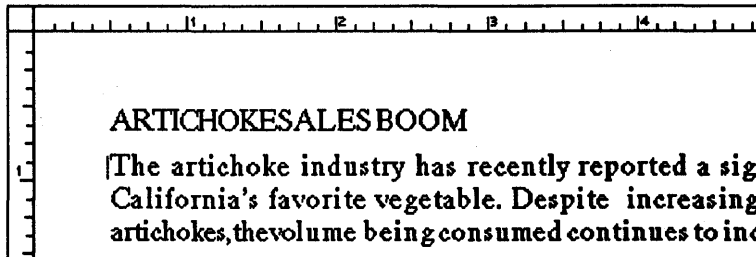

## Creating and Formatting New Paragraph Styles

### Theory

Creating and formatting a new paragraph style requires five basic steps:

1. With Publisher in Paragraph mode, you select one of the paragraphs in the work area. When possible, you should select a paragraph in a style most like the one you want to create. That way, formatting the new paragraph style will be easiest.
2. You use the **Copy Para Style** command to make a copy of the existing paragraph style. This is where you name the new style.
3. In the work area, you select one or more paragraphs that will be formatted in the new style.
4. You click on the paragraph style name in the mini-selector. This assigns the new paragraph style name to these selected paragraphs.
5. You format the attributes of the new paragraph style.

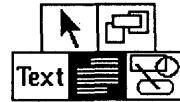

### Practice

First you'll create the **TITLE** and **HEADING** paragraph styles. (We use upper case letters to make it easier to identify the paragraph style names; you don't have to.)

**Copy Paragraph Style**

Old Name: **Body Text** \_\_\_\_\_

New Name: **TITLE** | \_\_\_\_\_

If Publisher is not in Paragraph mode, click on its icon in the toolkit. Then click on the string **ARTICHOKE SALES BOOM** in the work area.

Now display the Style Menu and choose the **Copy Para Style** command. The Copy Paragraph Style dialog appears, with **body text** in the Old Name field. Type **TITLE** in the New Name field and press the Enter key to exit the dialog.

Display the Copy Paragraph Style dialog again and this time type **HEADING** in the New Name field. Press the Enter key to exit the dialog.

With the line **ARTICHOKE SALES BOOM!** still selected, click on TITLE in the mini-selector. This assigns the TITLE paragraph style to the title text.

Now choose the Character command from the Attributes Menu. Note that the Character dialog now identifies the paragraph style as "TITLE." (If it doesn't, exit the dialog and repeat the assignment procedure just described.)

In the Character dialog, make these changes:

- Click on Bold in the style window.
- Click in the custom size field, press Esc and type 36.

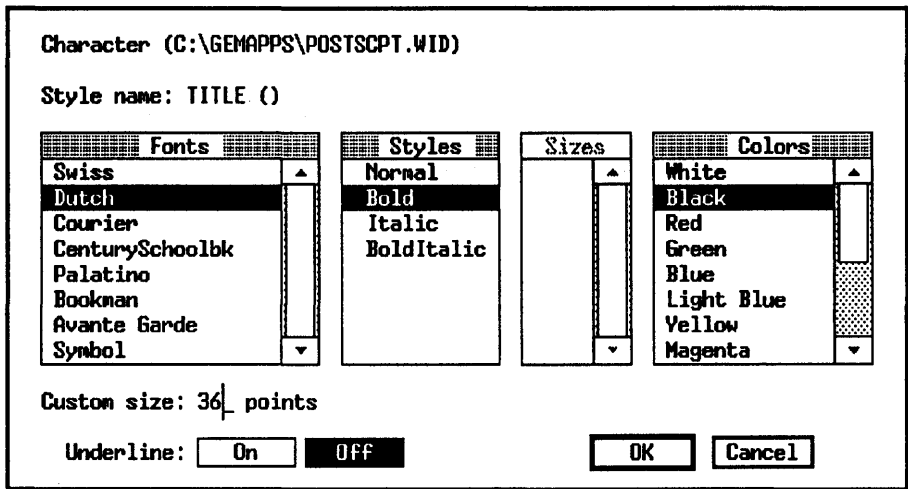

Press the Enter key to exit the dialog.



Display the Attributes Menu again and choose the **Paragraph** command. Make these changes in the Paragraph dialog:

- Set Line Space to zero. (Press the Esc key.)
- Clear the Space Below field and type .5.
- Click on the Center Alignment button.

<b>Paragraph</b>		(Units = inches)		
Style name: TITLE ()				
Left Indent: 00.000	Line Space: __. __			
Right Indent: 00.000	Space Above: 00.000			
First Line Indent: 00.000	Space Below: .5			
Tracking: 000.00 %				
Alignment:	<input type="button" value="Left"/>	<input type="button" value="Right"/>	<input checked="" type="button" value="Center"/>	<input type="button" value="Justified"/>
Text grid:	<input type="button" value="On"/>	<input checked="" type="button" value="Off"/>		
Ignore Space Above:	<input checked="" type="button" value="On"/>	<input type="button" value="Off"/>	<input type="button" value="OK"/>	<input type="button" value="Cancel"/>

Press the Enter key or click on OK.

The TITLE paragraph style is now 36-point Dutch Bold type, centered on the page, and spaced a half inch above the text body.

To format the HEADING paragraph style, scroll the window until **Vive La France** is visible, click on that line, and then click on HEADING in the mini-selector window.

Format HEADING as you did TITLE, with these values:

Character Swiss font, Bold style, and 20-point size

Paragraph Change Line Space to zero and Space above to .2. Set the alignment to Left.

Here is what the HEADING paragraph style looks like when you've finished formatting it:

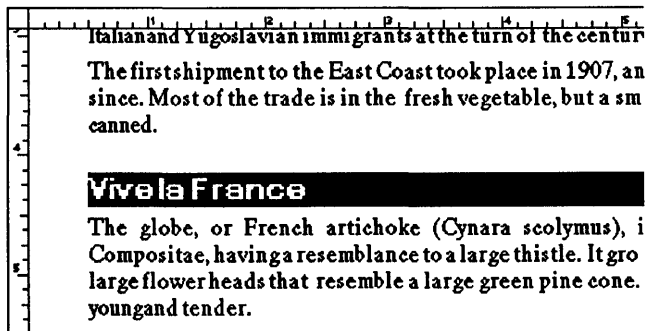

## **Bringing Graphics into Your Document**

### **Theory**

To add graphics to your document, you draw a new rectangle on the page. If you draw the rectangle on top of a rectangle containing text, the text automatically “flows” around the new rectangle. Using the mini-selector in the toolkit, you select the name of the graphics file you want to add. Publisher inserts the picture or image into the new rectangle.

Once the picture or image is in the rectangle, you can move it about on the page, add a colored or patterned background, fit it to the rectangle or scale it, and fit the text to it in a number of ways.

## Practice

To add the map to your document:

1. Scroll all the way to the right, and then scroll down so that the first line of the text body is near the top of the work area.
2. Switch to Rectangle mode.
3. Using the rulers and the illustration below as guides, draw a rectangle approximately two and three-quarters inches square, right-aligned with the base rectangle. To draw the rectangle, hold down the mouse button, drag, and then let up the mouse button when the rectangle is the right size.



Note how the text automatically flows around the new rectangle.

4. Go to the mini-selector and click on the file extension indicator until it reads \* .GEM. Then click on the filename FIG1 in the mini-selector window. Publisher reads FIG1.GEM into your new rectangle.

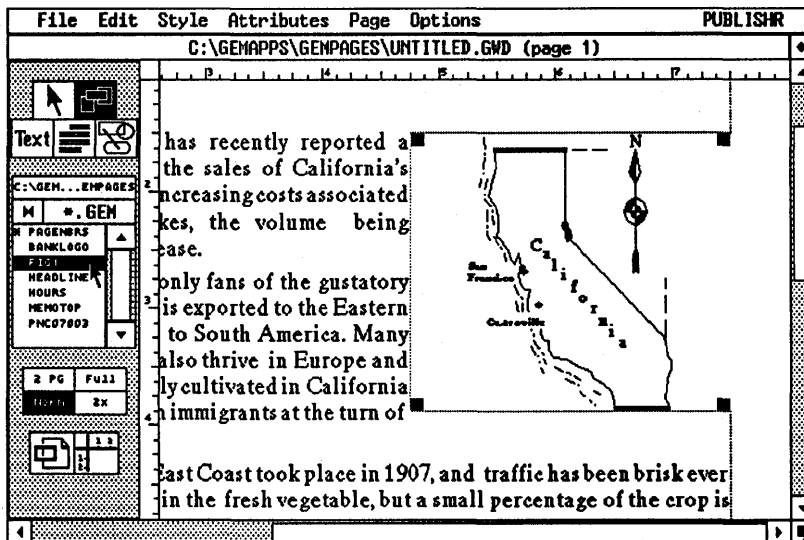

## Adding a Page Number

### Theory

Many documents (including this manual) use headers (“running heads”) that appear on each page. In this tutorial you’ll add a very common type of header, a page number.

Because the page number is at the bottom of the page, it is often called a “footer,” but note that Publisher makes no distinction between headers and footers. They are all called headers, regardless of where they appear on the page.

Headers in Publisher are actually *graphics files* created with GEM Draw Plus. This means you can combine words and pictures in your headers. A typical header would combine a document title with a horizontal line across the top of the page, but you could also create a design that you want to appear on each page.

The **Make Header** command tells Publisher that the selected rectangle is to be treated as a header and causes it to be repeated from page to page. Note, however, that you must choose the **Make Header** command on the first page that will have a header, *before* you go on to the next page of the document.

For example, let’s say you are on page 3 of your document when you add a page number file and choose the **Make Header** command. In that case, you’ll automatically have page numbers on page 3 and all subsequent pages, but to have numbers on page 1 and page 2, you must go back and add the page number on each page.

Several page number files are included in the Publisher package. Section 9 describes how you can create your own header files.

## Practice

To add a page number at the bottom of this page:

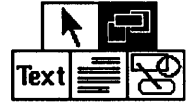

1. Switch to Rectangle mode by clicking on its icon in the toolkit.
2. Scroll to the bottom left of the page by dragging the vertical slider all the way to the bottom of its track and the horizontal slider all the way to the left.
3. Using the rulers as a guide and starting at the lower left corner of the base rectangle, drag a rectangle seven inches wide (the same as the base rectangle) and half an inch high.

On most display monitors, you won't be able to do this in a single step. When you've dragged the rectangle as far to right as you can, release the mouse button. Then drag the horizontal slider (at the bottom of the window) all the way to the right. Finally, switch to Select mode and drag one of the rectangle's handles until the new rectangle is as wide as the base rectangle.

4. In the mini-selector, make sure the file extension indicator still reads **\*.GEM**. Then click on **\*PAGENBRS** in the mini-selector window. This brings the contents of the page number folder into the window.

- Click on **PNC07003**. Publisher reads the page number file into the rectangle. Note that it says **page <\$page>**. The **<\$page>** is a special code that Publisher turns into the actual page number.

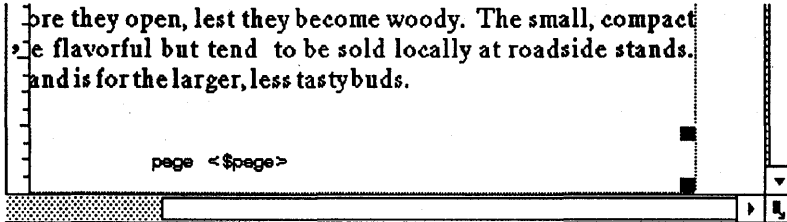

- Display the Edit Menu and choose the **Make Header** command. Publisher changes the **<\$page>** code to the page number.

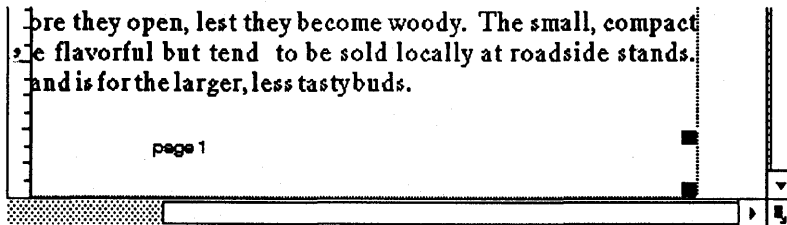

## Saving Your Work

### Theory

As you're working on the document, it's a good idea to save it from time to time. The first time you save it, use Publisher's **Save as** command so you can give the document a name. From then on, the **Save** command protects you from losing your work due to power outages or other unexpected occurrences.

### Practice

To name and save your document for the first time, display the File Menu and choose the **Save as** command. Publisher displays the Item Selector.

Note that the "Directory" line in the Item Selector reads

**C:\GEMAPPS\GEMPAGES\\*.GWD**. This means your document will automatically be saved to the GEMPAGES folder. (You can save your documents to other folders, as described in Appendix D, but for the purposes of this tutorial, GEMPAGES is just the ticket.)

Note also that the text cursor is in the "Selection" line. To name and save your document, you need only type a name and exit the dialog. Type **TUTORDOC** and press the Enter key. You don't have to enter the .GWD extension; Publisher supplies it automatically.

Next, an alert comes on your screen that says "Style Sheet not saved, specify style sheet name." When you click on the OK button, the Item Selector appears, this time listing the style sheet (.STL) files in the GEMPAGES folder. Type **TUTSTYLE** and press the Enter key.

The document and stylesheet have now been saved. The window's title bar now reflects the new name:

**C:\GEMAPPS\GEMPAGES\TUTORDOC.GWD (page 1)**



## Adding a Second Page

### Theory

To go to the next page of your document, you press the PgDn key. (To go to the previous page, once you've gone past page 1, you press the PgUp key.) Each time you press the PgDn key, Publisher displays the next page of the document.

**Note:** Regardless of how long your text file is, a page does not actually become part of the document until it is displayed on the screen. In other words, you must display each page of your document on the screen.

For example, to create a document that is five pages long, you must press the PgDn key to display all five pages on the screen. If you save and print the document after displaying only three pages, the printed document will be three pages long, even though your text file contains enough text for two more pages.

You can also press PgDn and go *past* the end of your document. When that occurs, Publisher shows a shaded text rectangle with a directory path (like **C:\MEMOS\LAUNCH.ASC**) in the upper left corner. To delete this extraneous page, display the Page Menu and Choose the **Delete Page** command. (Headers will continue to repeat indefinitely, long after you've exhausted your text file.)

### Practice

To display the next page of your document, press the PgDn key in the numeric keypad. If you're still scrolled to the bottom of the page, you'll see that the page number now reads **page 2**.

To format the headings on this page (refer to the illustration at the beginning of the tutorial for guidelines), switch to Paragraph mode, click on the heading text, and then click on **HEADING** in the mini-selector.

## Adding an Image File

### Theory

On page 1 you inserted a .GEM file into a graphics rectangle. On this page you'll insert a .IMG file.

A word about names. A .GEM file is called a "picture file." Picture files are created with applications like GEM Draw Plus, GEM Artline, GEM Graph, and GEM WordChart. A .IMG file is called an "image file." Image files are created with applications like GEM Paint, GEM Scan, and the Snapshot desk accessory. (GEM Paint, GEM Scan, and Snapshot *do* create a .GEM file, but this is for use with the GEM Output program. If you try to read one of these output files into a rectangle, Publisher automatically gets the corresponding .IMG file and reads it into the rectangle.)

### Practice

The image file will add the decorative letter "T" to the beginning of your paragraphs. To add the .IMG file:

1. Scroll to the top left of the page. Switch to Text mode and place the text cursor in front of the "T" in "The." Press the Del key to delete the letter.

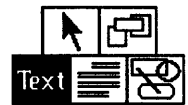

2. Switch to Rectangle mode and, using the rulers and the illustration on the next page as guides, draw a rectangle three-quarters of an inch wide and five-eighths of an inch high.

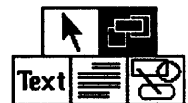

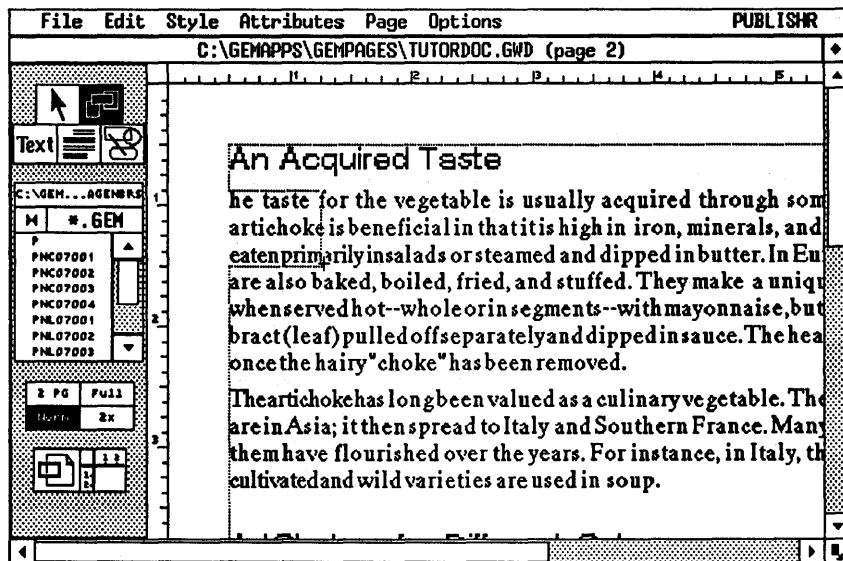

3. In the mini-selector, click on the close box to come back up a directory level. The pathname should again read **C:\GEM...EMPAGES**. Now click on the file extension indicator until it reads **\*.IMG**.
5. In the mini-selector window, click on **TTT.IMG**.

To add the decorative letter to the first paragraph of the section "A 'Choke of a Different Color," you have two choices:

- You can scroll down the page and repeat the steps you just completed.
- You can copy the graphics rectangle. To do so, switch to Select mode and select the rectangle. Display the Edit Menu and choose the Copy command. Display the Edit Menu again and choose the Paste command this time. A copy of the rectangle appears directly on top of the first one. Now you can drag the copy down to where it belongs.

## Adding Graphics with Publisher

### Theory

Publisher's Graphics mode makes it possible for you to draw circles, rectangles, rounded rectangles, and lines on your document pages. You can use these graphics elements for a variety of purposes—for example, to put a box around a picture or to draw lines separating sections of text.

For the filled elements (rectangle, rounded rectangle, and circle), you can specify colors and fill patterns and whether the element is transparent or opaque. You can also set the thickness and style of the element's outline, or you can specify an element with no outline at all.

The line element's attributes include its color, style (solid, dashed, or dotted), and its end style (squared, rounded, or an arrow).

Before going further, an important distinction needs to be made between graphics *elements* and graphics *rectangles*. A graphics element is what you draw with Graphics mode; that's what you'll do in this step. A graphics rectangle is entirely different; it contains graphics from an application like GEM Draw Plus or GEM Paint.

### Practice

In this step you'll use Publisher's Graphics mode to draw a line that separates the title from the rest of the text.

1. Press the PgUp key to return to the first page. Scroll back to the top of the page, so the title is again visible. Scroll the window horizontally so the title is in the center of the work area.
2. Switch to Select mode and select the base rectangle.

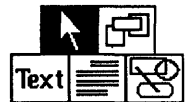

- 3. Switch to Graphics mode by clicking on its icon in the toolkit.

Note that switching to Graphics mode has changed the toolkit. The mini-selector has been replaced by the icons for the four graphics elements, plus a graphics selector icon.

- 4. Click on the line element icon in the toolkit.
- 5. Using the rulers and the illustration below as guides, drag a four-inch horizontal line. Place the pointer below the 2-inch mark on the ruler, press and hold down the mouse button, drag to the 6-inch mark, and release the mouse button.

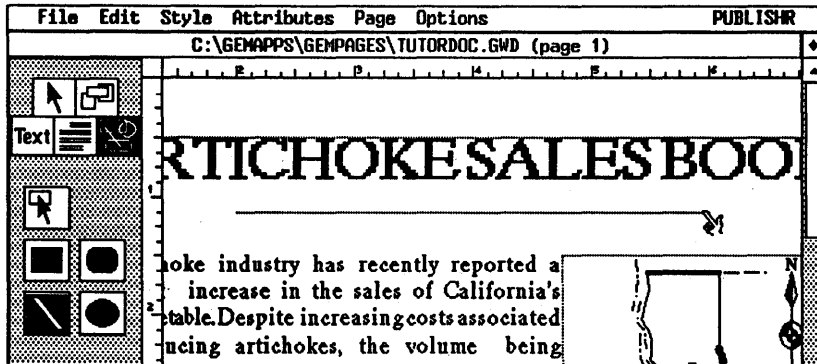
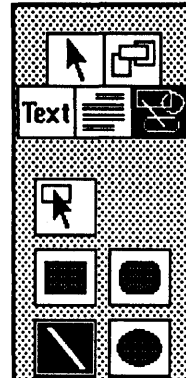
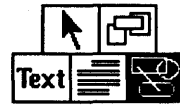

6. Display the Attributes Menu and choose the **Line Attributes** command. In the Line Attributes dialog, press the Esc key to clear the Line Width field and type **.1**. To round the ends of the line, click on the rounded end style in both columns of the dialog. Press the Enter key to exit the dialog.

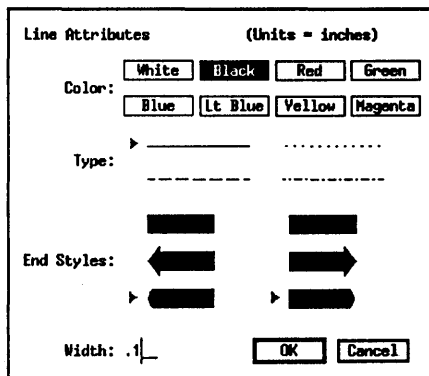

The reason you didn't add the line when you were first working on page 1 is this: Graphics elements like the line are "attached" to rectangles—the line is attached to the base rectangle. If the rectangle to which the graphics element is attached repeats from page to page (like the base rectangle), the graphics element also repeats from page to page—*unless* you go to the second page before adding the graphics element.

To add the decorative letter to the text on page 1, you can follow the steps given earlier, or you can do this:

1. Go back to page 2. (PgDn)
2. Select and Copy one of the image files.
3. Return to page 1. (PgUp)
4. Paste and place the image file on the page twice.

## Printing Your Document

### Theory

To print your document, you must save it one last time (using the **Save** command) and then go to the GEM Output program. If the printer is connected to someone else's computer, Publisher provides a **Copy Print Files** command that copies the necessary files to a floppy disk. Section 8 describes **Copy Print Files** and a related command, **Copy Document**.

### Practice

Before you print the finished document, display the File Menu and choose the **Save** command. Then display the File Menu again and choose the **To Output** command.

When GEM Output appears on the screen, you'll see the name of the tutorial document's output file (**TUTORDOC.GMP**) in the output list.

To start printing, click on the Start button at the upper left. As it processes your file, Output displays a message at the bottom of the screen that tells you the status of your printing job. The high-resolution fonts and graphics files require a certain amount of processing time, but in a few moments you should see the fruits of your labors.

Congratulations! The tutorial is finished.

The rest of this manual describes Publisher's many other features, features that open up a wealth of possibilities in desktop publishing.

---

# Creating a Style Sheet

**S**tyle sheets are special files containing information that determines how your documents look. This information includes:

- fonts (typefaces)
- type styles (bold, italic, etc.)
- type sizes (in points)
- text colors
- indents
- line and paragraph spacing
- text alignment
- hyphenation
- paragraph tabs

Style sheets can be applied to the text in any document. You can format your document with one style sheet and then, if you don't like the way it looks, reformat it with another. In this way style sheets make possible a stylistic consistency within your documents and across several documents, while at the same time giving you great flexibility in your document design.



## Paragraphs

Style sheets are made up of *paragraph styles* that work on the paragraphs in your document. A paragraph can be a single character, a word, a sentence, or several sentences. In ASCII files, paragraphs are separated by a blank line (in technical terms, by two carriage return-line feed <CR><LF> characters). The following example shows four paragraphs of ASCII text. Each <CR><LF> is represented by the symbol ↵.

```
A ↵
↵
paragraph ↵
↵
This is a paragraph. ↵
↵
This is what you usually think of as a ↵
paragraph. It has several sentences. The text ↵
wraps at the end of each line and continues ↵
on a new line. ↵
```

In formatted word processor text and in Publisher's Text mode, only a single <CR><LF> is needed to define a paragraph. Publisher would treat the text in the following example as four separate paragraphs, even though there are no blank lines between them.

```
A ↵
paragraph ↵
This is a paragraph. ↵
This is what you usually think of as a ↵
paragraph. It has several sentences. The text ↵
wraps at the end of each line and continues ↵
on a new line. ↵
```

## Paragraph Styles

If you look at a printed document, you'll often see considerable variety on the page. You might see a fourteen-point bold sans serif font (like Swiss) for headings and a ten-point serif font (like Dutch) for the main text body. Publisher's paragraph styles make this variety possible.

The paragraph styles you create and define determine the way your document looks. The style sheet for a simple document might contain only a few paragraph styles; the style sheet for a complex document typically contains a larger number of paragraph styles.

All style sheets must have a paragraph style called Body Text. When you start a new style sheet, Publisher automatically assigns the Body Text style to your entire document, unless you have included paragraph styles in your text file (as described later in this section). You can set the attributes of Body Text, but you cannot delete it from the style sheet.

Creating a style sheet involves this general sequence of steps:

1. Format the Body Text paragraph style. In this context "format" means to set its attributes: font, point size, spacing, alignment, hyphenation, tabs, and so on.
2. Create a new paragraph style by copying an existing one and giving the copy a new name.
3. Assign the new paragraph style to one or more paragraphs.
4. Format the new paragraph style.
5. Repeat these steps to create, assign, and format additional paragraph styles.
6. Save the document and its style sheet.

If you've completed the tutorial, you've already created a simple style sheet. This section goes into greater detail, fully describes the formatting dialogs, and provides some background information and hints, including how to prepare your text file to take advantage of existing style sheets.

## Creating New Paragraph Styles

Here is an overview of how you create new paragraph styles, set paragraph style attributes, and assign paragraph styles to your text. First, you must have text in a rectangle and Publisher must be in Paragraph mode.

To create a new paragraph style:

1. Select any paragraph in the text. Publisher highlights the paragraph by reversing the text and background colors (for example, putting white letters on a black rectangular background).
2. Choose the **Copy Para Style** command from the Style Menu. Publisher displays the Copy Paragraph Style dialog.
3. Move the text cursor in the Copy Paragraph Style dialog to the "New Name" field. Type the name of your first additional paragraph style. You can use any name you want, except Body Text or one already in the paragraph style list.
4. Click on the dialog's OK button or press the Enter key.
5. Repeat steps 2-4 for each additional paragraph style.

At this point the additional paragraph styles all have exactly the same attributes as the paragraph style you selected in step 1; only the names are different. You make the paragraph styles unique by formatting them.

You can create several style sheets that use the same set of style names (for example, each style sheet might have a TITLE paragraph style), giving them different attributes each time. This makes it possible for you to compare how a document looks when formatted with the various style sheets and choose which one you prefer. See "Creating a 'Matched Set' of Style Sheets," later in this section.

## Setting Paragraph Style Attributes

To set paragraph style attributes:

1. In the mini-selector, click on the name of the paragraph style you want to format. This assigns the paragraph style to the selected paragraph.
2. Using the **Character** command from the Attributes Menu, format the character attributes for that paragraph style. "Formatting Characters," later in this section, describes the character attributes in detail.
3. Using the **Paragraph** command, format the paragraph attributes for that paragraph style. "Formatting Paragraphs," later in this section, describes the paragraph attributes in detail.
4. Using the **Hyphenation** command from the Attributes Menu, choose the type of hyphenation (if any) desired for that paragraph style. See "Hyphenation" later in this section.
5. Using the **Paragraph Tabs** command, format the tab settings for that paragraph style. "Formatting Paragraph Tabs," later in this section, describes paragraph tabs in detail.

## Assigning Paragraph Styles

After you've created and formatted your paragraph styles, assign the styles to your document by doing this:

1. Select a paragraph to which you want to assign a paragraph style. To select a group of paragraphs, use the Shift-click technique.
2. Click on the style's name in the mini-selector. This assigns the paragraph style to the selected paragraph or paragraphs.
3. Continue assigning styles in this manner for each page of the document.

Assigning styles page-by-page can be time-consuming, but here is a technique that can save you time and effort:

- You can insert paragraph style names into your text file when you create it. This will greatly speed up formatting your document. See "Embedding Style Codes in Text Files" later in this section.
- If possible, use the Full page size for assigning paragraph styles. Although much of the text will probably be greeked, you should be able to distinguish the individual paragraphs.

## Formatting Characters

When you choose the **Character** command from the Attributes Menu, Publisher displays the Character dialog:

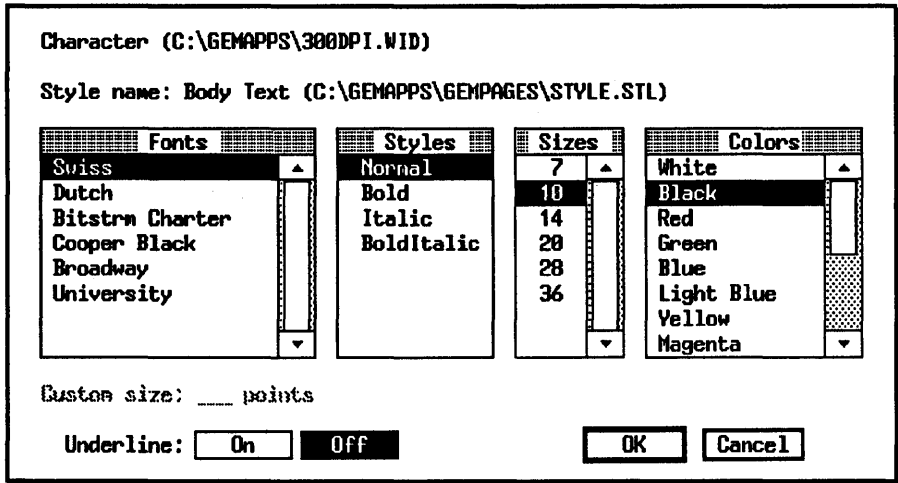

**Style name** Identifies the paragraph style of the selected paragraph, plus the current style sheet name. *Check this field before you begin formatting.* If it has the wrong style name, cancel out of the dialog and click on the correct style name in the mini-selector.

If you haven't yet saved a style sheet, a pair of empty parentheses () follows the style name.

**Fonts** Sets the typeface for the current paragraph style. You can only select one font. The list identifies the fonts specified in the currently selected width table file (identified at the top of the dialog).

- Styles**            Sets the type style for the text in the current paragraph style.
- Sizes**            Sets the point size for the text in the current paragraph style. In traditional typography, 72 points equals one inch. Any variations in type size in printed output is a function of the printer, not Publisher.
- If you are using a PostScript width table, the Sizes window is disabled. To set the point size, edit the "Custom size" field below the Fonts window.
- Colors**            Sets the color for text in the current paragraph style. White text is only visible when set on a colored background.
- Underline**        Underlines all text in the current paragraph style.

## Formatting Paragraphs

When you choose the **Paragraph** command from the Attributes Menu, Publisher displays the Paragraph dialog:

<b>Paragraph</b>		(Units = inches)		
Style name: <b>Body Text</b> (C:\GEMAPPS\GEMPAGES\STYLE.STL)				
Left Indent: 00.000	Line Space: 00.028			
Right Indent: 00.000	Space Above: 00.058			
First Line Indent: 00.000	Space Below: 00.058			
Tracking: 000.00 %				
Alignment:	<input checked="" type="radio"/> <b>Left</b>	<input type="radio"/> <b>Right</b>	<input type="radio"/> <b>Center</b>	<input type="radio"/> <b>Justified</b>
Text grid:	<input checked="" type="radio"/> <b>On</b>	<input type="radio"/> <b>Off</b>		
Ignore Space Above:	<input checked="" type="radio"/> <b>On</b>	<input type="radio"/> <b>Off</b>	<input type="button" value="OK"/>	<input type="button" value="Cancel"/>

### Units =

Identifies the unit of measure in the fields in this dialog. To change the unit of measure, use the **Rulers in Inches/Picas** command or the **Image Size** command in the Page Menu.

In pica notation, a comma separates picas from points. For example, a value of 2,01 means 2 picas plus 1 point. A pica equals twelve points (one-sixth of an inch).



**Style name** Identifies the paragraph style of the selected paragraph, plus the current style sheet name. *Check this field before you begin formatting.* If it has the wrong style name, cancel out of the dialog and click on the correct style name in the mini-selector.

If you haven't yet saved a style sheet, a pair of empty parentheses () follows the style name.

**Left Indent** Sets the left margin for text in this paragraph style, measured from the left side of the *text column*, not the page. (In single-column text, the column is the same as the rectangle.)

To edit this field and the other numeric fields in this dialog, do the following:

1. Move the cursor to the field, using the up- or down-arrow, Tab or Shift-Tab, or the mouse.
2. Press Esc to clear the field. If you want the value in the field to be zero, simply leave the field blank.
3. Enter the new value in the field.

To enter a decimal value (like .075), type the decimal point and the numbers; you don't need to type a zero before the decimal.

**Right Indent** Sets the right margin for text in this paragraph style, measured from the right side of the rectangle.

**First Line Indent**

Sets the indent for the first line of each paragraph in this style. You can enter a negative value in this field, creating a "hanging indent." The negative First Line Indent is also used for creating bulleted paragraphs. See Section 6.

**Line Space** Sets the space between the lines *within each paragraph* in this style. In traditional typography, Line Space is called "leading."

This setting has no effect on the spacing between the paragraphs themselves. The default setting is zero, where the baseline-to-baseline distance between lines equals the current point size. For example, for 10-point type the distance is 10 points. By increasing the line space, you can create Body Text that appears double-spaced or triple-spaced, and so on.

**Space Above** Sets the amount of space *above the first line* of each paragraph in this style.

**Space Below** Sets the amount of space *below the last line* of each paragraph in this style.

**Note:** The space between paragraphs is the *sum* of the Space Below value for the first paragraph and the Space Above value for the second.

**Tracking** Increases or decreases the space between letters and words in this paragraph style.

The tracking percentage is based on the point size used. For example, if you have 10-point type and are tracking at 10%, the spacing is increased by one point. If you are tracking at -10%, the spacing is decreased by one point. This allows you to change the point size without having to change the tracking percentage. Thus, if you change from 10-point type to 30-point type, the increase in spacing changes from one point to three points; both are changed by a factor of three.

You can use tracking in combination with Publisher's kerning feature. Tracking works on entire paragraphs, and kerning has a similar effect on text in marked blocks. Kerning is described in Section 6.

- Alignment**      Sets the alignment for text in the current paragraph style. Publisher offers four alignment options:
- Left**              Text lines up against the Left Indent; also called "ragged right."
  - Right**             Text lines up against the Right Indent ("ragged left").
  - Center**            Each line is centered between the Left and Right Indents.
  - Justified**         Each line extends fully from Left Indent to Right Indent.

The illustration below shows examples of the four kinds of alignment.

This is an example of left-aligned text. Note how the text lines up against the left edge of the rectangle. Left-aligned text is also called "ragged right" text.

This is an example of right-aligned text. Note how the text lines up against the right edge of the rectangle. In left-aligned and right-aligned text, the words are always pretty much the same distance apart.

This is an example of centered text. Note how each line is centered in the rectangle. As with left-aligned and right-aligned text, the words are evenly spaced from each other.

This is an example of justified text. The text lines up against the left and right edges of the rectangle. To make this possible, Publisher must vary the space between words to fill out the length of the line. In justified text some lines may appear more dense or more open than others.

**Text Grid** Turns the text grid on and off for the current paragraph style. See "Text Grid," which follows.

### Ignore Space Above

Tells Publisher not to use this paragraph style's Space Above value for paragraphs that are at the top of the text rectangle. See the illustration below.

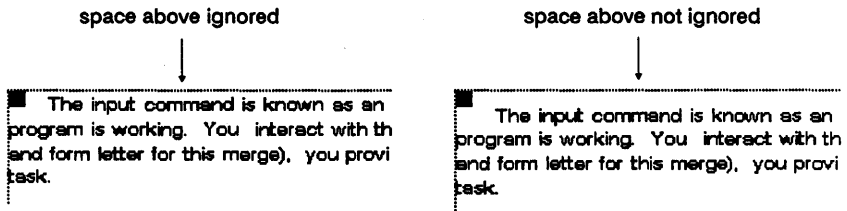

### Text Grid

The text grid is intended primarily for multiple-column text, to ensure that text in adjacent columns is properly aligned. If you are creating a single-column document, you should turn the text grid Off. If you don't, you may find your Space Above and Space Below settings overridden in certain instances, as described below. (The default is On, so that documents created with earlier releases of Publisher can be opened.)

For *Body Text* and *any other paragraph style whose type size is the same as Body Text*, the text grid takes priority over specific settings for Space Above and Space Below.

The illustration below shows how the text grid works. The dotted lines represent the text grid, which isn't visible on the screen.



The general rule is this: Paragraphs of text affected by the text grid always start on a grid line. If the sum of Space Above and Space Below is greater than the distance between grid lines, the paragraph automatically moves down to the *next* grid line.

The example on the left side of the illustration shows what happens when the sum of Space Above and Space Below is less than or equal to the distance represented by A. The example on the right shows what happens when the sum is greater than A but less than or equal to B. In both cases, the "Start of paragraph..." line has "snapped" to the next available grid line.

To bypass the text grid, simply turn it off for the paragraph style (or styles) in question. Remember that, with the text grid turned off, text in adjacent columns of multiple-column documents might not line up properly.

## Hyphenation

When you choose the **Hyphenation** command from the Attributes Menu, Publisher displays the Paragraph Hyphenation dialog:

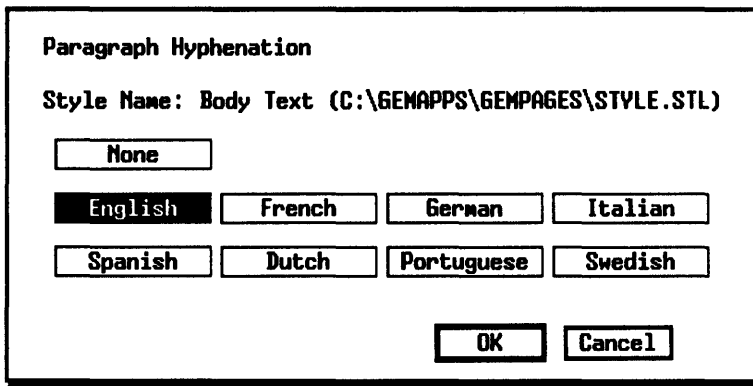

**Paragraph Hyphenation**

Style Name: Body Text (C:\GEMAPPS\GEMPAGES\STYLE.STL)

None

English French German Italian

Spanish Dutch Portuguese Swedish

OK Cancel

**Style name** Identifies the paragraph style of the selected paragraph, plus the current style sheet name. *Check this field before you begin formatting.* If it has the wrong style name, cancel out of the dialog and click on the correct style name in the mini-selector.

If you haven't yet saved a style sheet, a pair of empty parentheses () follows the style name.

The Paragraph Hyphenation dialog makes it possible for you to specify that text in the current paragraph style will not be hyphenated (the None button) or that it will be hyphenated according to the conventions of any of several different languages.

**Note:** You may encounter words that are hyphenated incorrectly. To deal with exceptions and special cases, you can choose the **Hyphenate Word** command in the Options Menu. This command displays a dialog in which you can add or delete words in a hyphenation exception dictionary.

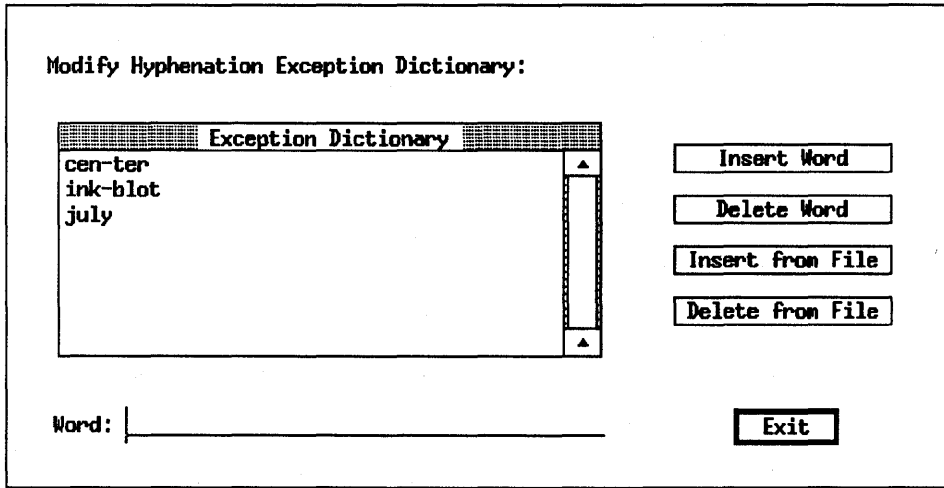

To add a word to the exception dictionary, type it in the Word field at the bottom of the dialog and then click on the Insert Word button. To delete a word from the dictionary, you can:

- Type the word in the Word field and then click on the Delete Word button.
- Scroll the Exception Dictionary window until the word comes into view, click on the word (this makes it appear in the Word field), and then click on the Delete Word button.

You can also use the hyphenation exception dictionary to add words that you do *not* want hyphenated, like **july** in the illustration. Any word that appears without hyphenation in the dictionary will not be hyphenated in your documents.

You can also create files of words to add to or delete from the dictionary. Using a word processor like GEM 1st Word Plus, create an ASCII file of hyphenated words. When you return to Publisher, choose the **Hyphenate Word** command to display the exception dialog. To add the words in the file you just created, click on the Insert from File button; to delete the words contained in the file, click on the Delete from File button. Publisher displays the Item Selector so you can identify the file containing the words to be added or deleted. (The Item Selector is described in detail in Appendix D.)



## Formatting Paragraph Tabs

When you choose the **Paragraph Tabs** command from the **Attributes Menu**, Publisher displays the **Paragraph Tabs** dialog:

**Paragraph Tabs** (Units = inches)

Style name: Body Text (C:\GEMPAGES\STYLE.STL)  
 Decimal Tab Character: [.]

Tab Stop		Tab Stop	
1: 00.000	L R C D	9: 07.200	L R C D
2: 01.600	L R C D	10: ____	L R C D
3: 02.400	L R C D	11: ____	L R C D
4: 03.200	L R C D	12: ____	L R C D
5: 04.000	L R C D	13: ____	L R C D
6: 04.800	L R C D	14: ____	L R C D
7: 05.600	L R C D	15: ____	L R C D
8: 06.400	L R C D	16: ____	L R C D

**Units =** Identifies the unit of measure in the fields in this dialog.

**Style name** Identifies the paragraph style of the selected paragraph, plus the current style sheet name. *Check this field before you begin formatting.* If it has the wrong style name, cancel out of the dialog and click on the correct style name in the mini-selector.

If you haven't yet saved a style sheet, a pair of empty parentheses () follows the style name.

The **Paragraph Tabs** dialog determines how Publisher treats tab characters in your text file. You can set up to sixteen tab stops, aligning the text

to the left or right, centrally, or decimally at the tab stop. Publisher supplies nine default tab stops, but you can change them.

**Note:** If you are using a single tab stop, set all other values in the dialog to zero. Publisher automatically sorts tab stops in ascending order. Thus, if you enter a first tab stop of 4 inches but leave the second and third stops at 1.6 inch and 2.4 inch, Publisher resets the stops to 1.6, 2.4, and 4 inches in that order.

Tab stops are always measured from the current paragraph style's Left Indent value. For example, if the Left Indent is .5 inches and the first tab is set to .2 inches, the first tab stop actually occurs .7 inches from the left side of the text rectangle.

Here's how to set tab stops:

1. Move the cursor to the tab stop field.
2. Press Esc to clear the field.
3. Enter the tab stop, in the current unit of measure as indicated at the top of the dialog.

To enter a decimal value like .075, simply type the decimal point and the number; you don't have to type a zero before the decimal.

The buttons following the field determine the alignment of the tabbed text:

- |              |                                                                                                                                                                                                                                                                                          |
|--------------|------------------------------------------------------------------------------------------------------------------------------------------------------------------------------------------------------------------------------------------------------------------------------------------|
| L (Left)     | Tabbed text <i>starts</i> at the tab stop.                                                                                                                                                                                                                                               |
| R (Right)    | Tabbed text <i>ends</i> at the tab stop.                                                                                                                                                                                                                                                 |
| C (Centered) | The text is centered at the tab stop.                                                                                                                                                                                                                                                    |
| D (Decimal)  | Decimal Tab Characters align at the tab stop. The default Decimal Tab Character is a decimal point (a period), but the field is editable. You can follow European convention and use a comma, or you can use any other letter, number, or punctuation symbol as a Decimal Tab Character. |

## Using Paragraph Tabs

You can use paragraph tabs to create tables, as in this illustration:

	<b>Right</b>	<b>Left</b>	<b>Center</b>	<b>Decimal</b>
1	Travel	Memphis	deductible	\$279.95
		Mobile	taxable	495.06
		Abilene	taxable	17.40
1	Meals	breakfast	taxable	5
		lunch	deductible	12.75
		dinner	inedible	197.32
2	Recreation	sports	tennis	73.50
			jogging	50.00
		billiards	275	
		gum	sugarless	.75
		movies	PG or PG-13	5.00
All taxable and deductible items in this accounting have been duly reported to the Internal Revenue Service.				

The text file that produced the table looked like this:

**@COLHEADS = =>Right=>Left=>Center=>Decimal**

**=>Travel=>Memphis=>deductible=>\$279.95**

**=>=>Mobile=>taxable=>495.06**

**=>=>Abilene=>taxable=>17.40**

**=>Meals=>breakfast=>taxable=>5**

**=>=>lunch=>deductible=>12.75**

**=>=>dinner=>inedible=>197.32**

**=>Recreation=>sports=>tennis=>73.50**

**=>=>=>jogging=>50.00**

**=>=>=>billiards=>275**

**=>gum=>sugarless=>.75**

**=>movies=>PG or PG-13=>5.00**

**@INDENT PARA = =>All taxable and deductible items in this**

**=>accounting have been duly reported to the**

**=>Internal Revenue Service.**

In the example file, the symbol  $\Rightarrow$  indicates a tab character. The code **@COLHEADS =** indicates a paragraph style. Paragraph style codes are described in detail later in this section. Paragraphs without explicit style code names are Body Text.

Here are the attributes of the paragraph styles in the table:

COLHEADS	Character: Dutch, 14 point, Bold with Underline turned on. Paragraph: All indents and spacing set to zero; text grid turned off. Paragraph Tabs: same as Body Text (see below), except fourth column. See "Decimal Tabs," which follows.
Body Text	Character: Swiss, 10 point, Normal. Paragraph: All indents and Space Below set to zero. Line Space set to <b>.02</b> ; Space Above set to <b>.10</b> . Text grid off. Paragraph tabs as follows: <ul style="list-style-type: none"> <li>● first column: right-tabbed at one inch</li> <li>● second column: left-tabbed at 1.75 inch</li> <li>● third column: centered at three inches</li> <li>● fourth column: decimally tabbed at four inches</li> </ul>
TABBED PARA	Character: same as Body Text. Paragraph: Space Above set to <b>.20</b> ; all other values set to zero. Paragraph Tabs: left-tabbed to 1 inch.

## Decimal Tabs

Because decimal tabs use a Decimal Tab Character (usually a period) for alignment, they follow a special rule: Decimally tabbed text (words as well as numbers) that doesn't have a Decimal Tab Character in it is treated as if it were *right-tabbed*. This ensures that whole numbers and decimals line up properly in a column. In the illustration, **5** and **275** are examples; they don't contain a decimal point.

The word "Decimal" in the column heads appears to violate this rule, but that is because the fourth column of the COLHEADS paragraph style is centered, *not* decimally tabbed.

## Word Processor Tabs

Some word processors do not insert a true tab character (ASCII decimal 9) in the file when you press the Tab key. For example, in its document mode WordStar uses blank spaces to align text to tab positions.

**Note:** When Publisher encounters three or more consecutive blank spaces in a line of text, it automatically converts them to a *single* tab character.

You can insert tabs into your text with Publisher by switching to Text mode, placing the text cursor where you want the tab, and pressing the Tab key.

## Saving Style Sheets

When you have created paragraph styles and formatted them, you can save them as a style sheet. To save a style sheet, choose the **Save Style Sheet** command from the Style Menu. Enter a name in the Item Selector, and press the Enter key or click on the OK button. The Item Selector is described in Appendix D.

Once saved, a style sheet can be used over and over, with the **Get Style Sheet** command.

## Style Codes

When you assign paragraph styles to your document Publisher inserts codes in your text file to “turn on” the styles. The codes all take this form:

**@stylename =**

where **stylename** is the paragraph style name you have assigned, and where the equals sign (=) is followed by a single blank space. (The blank space is optional, but makes your text more readable and easier to edit.) These codes become part of the document’s text (.ASC) file when the document is saved. (Appendix A describes in detail how Publisher handles text files, including how the .ASC file is created.)

The following text file sample has two paragraph styles in addition to Body Text: TITLE and HEADING. (The underscore is only for identification of the paragraph styles; it doesn’t appear in the file.) Paragraphs without a style code are Body Text.

**@TITLE = THIS IS GEM DESKTOP PUBLISHER!**

**Welcome to the world of desktop publishing with your personal computer and GEM Desktop Publisher. Now you can produce your own newsletters, fliers, office publications, and marketing materials without having to hire an entire staff of writers, graphic designers, paste-up artists, and typographers.**

**@HEADING = Your Own Print Shop**

**GEM Desktop Publisher takes text from a variety of sources and lets you format it on the page until you’ve got it just the way you want it. You can use unformatted (plain ASCII) text from any word processor or text editor, and you can use formatted text ...**

Note that a style code is required at the beginning of *every* paragraph in a given style, except for Body Text. Contrast the following examples:

**@TITLE = First paragraph.**

**@TITLE = First paragraph.**

**@TITLE = Second paragraph.**

**Second paragraph.**

**@TITLE = Third paragraph.**

**Third paragraph.**

In the example on the left, all three paragraphs appear in a style called TITLE. In the example on the right, the first paragraph appears in TITLE; the other paragraphs appear in Body Text.

**Note:** If you want a literal at-sign (@) to appear at the beginning of a paragraph, enter two at-signs (@@). Anywhere else in a paragraph, you can enter a single at-sign.

## Embedding Style Codes in Text Files

As was noted earlier in this section, you can format a document page by page, assigning paragraph styles as you go. For a two- or three-page document this is no hardship, but it gets less rewarding as the document gets longer. To sidestep this issue entirely, you can insert the paragraph style codes in your text file at the time you're creating it. This approach offers two great advantages:

- When you load a style sheet whose paragraph styles match the codes you've embedded in the file, Publisher immediately formats your *entire* document.
- Embedded style codes are automatically added to the mini-selector's paragraph style list. If you haven't yet created a style sheet for these codes, having them already in the mini-selector speeds the process considerably.

Each time you choose the **Get Style Sheet** command to load a style sheet, Publisher reformats the text in your document according to the attributes in that style sheet. If the text file contains a style code not defined in the style sheet, the style name appears in the mini-selector, but all paragraphs in that style take on the attributes of **Body Text**.

For example, if your text file contains a style called **CHAPTER** that is not defined in the current style sheet, Publisher adds its name to the list of style names in the mini-selector. Until you format **CHAPTER**, it is identical to **Body Text**.

## Tips on Creating Style Sheets

Sometimes you can save yourself work by changing the order in which you copy and format paragraph styles. Here are a couple of instances:

- You can format **Body Text** before you copy it to create any additional paragraph styles. Use this sequence if the formatted **Body Text** has attributes you want to carry over to the new styles.

For example, you might not want a **First Line Indent** in any of your paragraph styles. If you copy the default **Body Text** to create your additional styles, you'll have to set the **First Line Indent** to zero when formatting each new style. If you format the **Body Text** first, the **First Line Indent** will already be zero.

- You can create and format one new style and then copy that style to create your additional styles. Use this sequence if the new styles all have a common attribute that is not shared with **Body Text**.

For example, **Body Text** might have a one-inch **Left Indent**, but all other paragraph styles might have a **Left Indent** of zero. If you create one new style and set the **Left Indent** to zero, all the other new styles will already have that attribute.



- You can copy existing paragraph styles without having to select them. To do so, choose the **Copy Para Style** command and then type the name of the paragraph style you want to copy in the Old Name field. If you want to copy a paragraph style while a paragraph in another style is selected, press the Esc key to clear the Old Name field and then type the name of the paragraph style you want to copy.
- You can create several style sheets, each of which uses the same paragraph style names, although their attributes differ from style sheet to style sheet. For example, you could have two style sheets, both with a paragraph style called **HEADING**. In one style sheet, **HEADING** might be 20-point Swiss type, and in the other it might be 20-point Dutch type.

Using the same paragraph style names allows you to try out different style sheets on a document by simply loading them with the **Get Style Sheet** command in the Style Menu. Because the paragraph style codes in the document are the same as those defined in each style sheet, the attributes in the new style sheets take effect immediately.

---

# Working with Text

**T**ext is the primary ingredient of any GEM Desktop Publisher document. You add text to a document by “pouring” a word processor file into a rectangle or by creating a new file with Publisher. You can use Publisher’s text-editing features to enter additional text, edit existing text, or change styles for blocks of text within paragraphs.

## Pouring Text into a Rectangle

To pour text from an existing word processor file into a rectangle in Publisher, you must select the rectangle and then click on the text filename in the mini-selector. (If you’re pouring text into the base rectangle of a new document, the base rectangle is already selected.)

Bringing the text filename into the mini-selector window typically consists of two steps:

1. You change the path in the mini-selector by clicking on the close box or folder names, as described in Appendix D.
2. You change the file extension indicator in the mini-selector to match the extension of your text file.

For example, if your text file was written with MultiMate and if you are using the default word processor extensions, set the file extension indicator to **\*.DOC**. Make sure the filter extensions in the Preferences dialog match the extensions you are using for your text files. For more on word processor file extensions, see “Filter Extensions” in the description of the **Set Preferences** command in Section 8 and “Text File Extensions” in Appendix A.

When you click on the filename in the mini-selector window, Publisher creates an ASCII (.ASC) version of the file, plus a temporary workfile (.TMP file) that it reads into the selected rectangle.

Appendix A describes Publisher’s word processor support and text file translations in detail.

## Text Flow in Rectangles

You can pour the same text file into more than one rectangle. For example, you might want a heading immediately to the left of your text body, as in the illustration below.

### OVERVIEW

GEM® 1st Word Plus™ is a word processor with the ability to incorporate graphics elements and displayed in true WYSIWYG screen. Using icons, drop-down menus, carry out a variety of word processing moving, copying, or changing text style

In this case, the position of the rectangles relative to each other is significant. The general rule is this: Text flows first into the rectangle whose top left corner is higher on the page, even if the difference is only a fraction of an

inch. If the top left corners of both rectangles are equally as high on the page, then text flows first into the rectangle on the left. In the illustration below, the numbers indicate the order in which the text flows into the rectangles in situations A, B, and C.

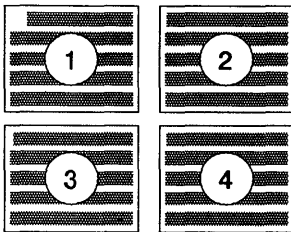

A.

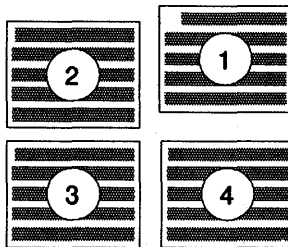

B.

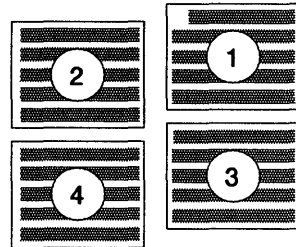

C.

## One Text File, Several Documents

There may be times when you want to create more than one document from the same text file. Remember, however, that text changes you make to one document will show up in any other document that uses the same .ASC file. For that reason, it's best to make a copy of the text file for each new document. For example, you might have a document that uses a text file called MEMO.ASC. To make additional documents from this same file, you would use the GEM Desktop or the COPY command to make additional text files called MEMO1.ASC, MEMO2.ASC, and so on.

## Text Mode

You can only enter or edit text in Text mode. To switch Publisher to Text mode, click on the Text icon in the mode switches.

In Text mode, the following changes take place on the Publisher screen:

- All rectangle outlines disappear.
- The mini-selector lists the available text styles: Normal, Bold, Italic, and Underline.
- The mouse form appears as an I-beam whenever it is inside the work area. For more on the I-beam, see "I-beam and Text Cursor," next.

## **I-Beam and Text Cursor**

The I-beam and the text cursor only appear when Publisher is in Text mode.

You use the I-beam primarily to place the text cursor for entering or editing text or to mark blocks of text.

### **Placing the Cursor in Your Text**

To place the cursor for entering or editing text, move the I-beam into the text rectangle and click. The text cursor appears where you clicked. As soon as you start typing, the I-beam disappears. It reappears when you move the mouse or if there is no activity from the keyboard for a set amount of time (15 seconds is the default).

This is also how you mark the place where you want to paste a block of text.

### **Text Cursor**

The text cursor is a vertical bar that indicates where your typed characters will appear and where your edits will occur. You can place the text cursor anywhere in a line of text. For example, if you leave out a letter in the middle of a word, you can put the I-beam where the missing letter belongs, click, and then type the letter. See "Entering Text" and "Editing Text" later in this section.

## **Marking Text Blocks**

A text block can be anything from a single character to the contents of an entire text rectangle. Marking a text block allows you to change its style, cut it, or copy it.

To mark a block, do the following:

1. Move the I-beam to the beginning of the block. Don't click the mouse button yet.
2. Press the mouse button and begin to drag. As you drag, Publisher highlights the block by reversing its colors (for example, placing white letters on a black background).
3. When the entire block is highlighted, release the mouse button. The block is now marked.

You can only mark one block at a time. Publisher immediately "un-marks" a block if you start marking another block.

## Using Publisher to Create New Text Files

You can use Publisher as a simple word processor for creating new text files. To do so, follow these steps:

1. In Rectangle mode, create the rectangle in which you will enter your text.
2. Switch to Text mode and click the I-beam anywhere in the text rectangle area. (The rectangle outline is no longer visible, so just aim for the middle of the rectangle. Accuracy is not important at this point.)
3. Publisher displays an alert telling you the new text file needs a name. Click on OK or press the Enter key to display the Item Selector.

(If you click on Cancel, you return to the empty rectangle in the work area. You can then switch to Select mode and use the rectangle to read in an existing text or graphics file.)

4. Give the new text file a name in the Item Selector. Publisher automatically supplies the .ASC file extension; you don't have to enter it in the Item Selector. Click on OK or press the Enter key.
5. The text cursor appears in the rectangle's upper left corner. You can begin typing.

**Note:** The text you type appears with the current attributes of the Body Text paragraph style. To assign paragraph styles to the new text, switch to Paragraph mode, get a style sheet (if one isn't already loaded) or create one, and assign styles as described in Section 5.

## Entering Text in Existing Files

You can use Publisher to add text to your documents. To add text within a paragraph, switch to Text mode and click the I-beam in the text rectangle at the point where you want to enter text. When the text cursor appears, begin typing. The new text takes the attributes of the paragraph. To add a new paragraph to the text, switch to Text mode and then:

1. Place the text cursor at the end of the paragraph just *before* where you want the new one.
2. Press the Return key.
3. Start typing.

In this case, the new paragraph takes on the paragraph style of the one just before it.

## Entering Special Characters

You can enter special characters into your document—characters that are not otherwise available on the keyboard, like the copyright and trademark symbols—by using the Alt key and the Decimal character value listed in the *Fontware™ Installation Guide*. For example, to enter the copyright symbol (©), type Alt-189. Make sure you use your computer's numeric keypad, not the numbers at the top of the regular alphabet keys.

You can also insert special characters into your text file in your word processor in the same way. The only difference is that when entered in Publisher the special character will look as it should (the copyright symbol will look like a copyright symbol), but the word processor (unless it is graphics-based, like GEM 1st Word Plus) will substitute something for the special character. For example, WordStar shows an equals sign when you type Alt-189.



## Editing Text

Editing text includes simple typing corrections, word and line deletions, and text cursor movement. Cutting, copying, and pasting text blocks are discussed later in this section.

To edit text, first place the text cursor at the editing point by clicking the I-beam there; then use the editing and cursor movement keystrokes listed in the Editing Shortcuts dialog (displayed when you choose the Editing Shortcuts command from the Options Menu).

**Note:** The keystroke combinations vary according to the key mapping currently in place. The purpose of the key mappings is to match the editing keystrokes of Publisher to the editing keystrokes of the supported word processors. Appendix A describes key mappings and word processor support in detail.

In the following brief descriptions of the keystrokes, the notation (2) indicates that they are actually two separate keystrokes, as in Delete Character Left and Delete Character Right.

### Delete Character Left/Right (2)

Deletes the character to the left or right of the cursor.

**Delete Word** Deletes from the current cursor position to the beginning of the next word. If the cursor is at the blank space between words, deletes only the blank space.

**Delete Line** Deletes the line in which the cursor is located.

### Cursor to Line Start/End

A single keystroke combination (a toggle) that moves the cursor alternately to the beginning and end of the line.

**Next/Previous Word (2)**

Moves the cursor to the beginning of the next or previous word. If the cursor is in the middle of a word, Previous Word moves it to the beginning of the current word.

**Next/Previous Page (2)**

Displays the next or previous page in the work area. If there is no next page, this command adds a new page to the document.

**Page Top/Bottom (2)**

Displays the top or bottom of the current page in the work area.

**Character Up/Down (2)**

Moves the cursor to the same character position in the line above or below. The cursor skips over lines that do not contain any text.

**Character Left/Right (2)**

Moves the cursor one character to the left or right without erasing characters.

**Slider Up/Down (2)**

Scrolls the document up or down in the work area. These keystrokes have the same effect as clicking in the scroll bar above or below the slider. Scrolling is described in detail in your *GEM/3 Desktop User's Guide*.

**Slider Left/Right (2)**

Horizontal equivalents of Slider Up and Slider Down.

**Arrow Up/Down (2)**

Scrolls the document up or down in the work area. These keystrokes have the same effect as clicking on the up- or down-arrow. If you hold the keys down, the effect is continuous.

**Arrow Left/Right (2)**

Horizontal equivalents of Arrow Up and Arrow Down.

**Soft Hyphen** Marks an optional hyphenation point in a word. See "Hyphenation," following.

**Note:** When using a keystroke combination that includes the Ctrl (Control) key, hold down the Ctrl key and quickly press the other key. If you hear a beep, that means the GEM software has switched your keyboard to the mode in which it controls the movement of the mouse pointer; many of the editing keystrokes will no longer work. To use the keyboard for text editing, press the Ctrl key again. The second beep tells you the keyboard is no longer in mouse mode.

**Kerning**

The term *kerning* refers to a reduction in the space between letters. It is used primarily to make the spacing between all letters of a word appear equal. For example, without kerning in a word like "Valid", the space between the "V" and "a" can appear to be greater than the space between the remaining letters. With kerning, the adjacent letters can be made to overlap so that the apparent spacing between letters becomes the same. See the example below.

**Valid**

without kerning

**Valid**

with kerning

By marking a block (as described earlier in this section) and then choosing the **Character** command from the **Attributes Menu**, you can kern anything from a single character to an entire paragraph or more. The **Kerning** field, which is only visible in **Text mode** when a block of text is marked, appears at the lower right of the dialog.

Like tracking (described in Section 5), kerning is based on the point size of the type in the selected block. Thus, if you kern 10-point type at 10%, the characters are moved apart by one point. If you kern the same type at -10%, the characters are moved closer together by one point. To bring the "V" closer to the "a" in "Valid," you mark the "V" and give it a negative kerning value.

## Hyphenation

Publisher can hyphenate text on a paragraph style basis, as described in Section 5, and it also supports *soft* hyphenation.

A soft hyphen is also called a "conditional" hyphen. When you mark a word for hyphenation (the default keystroke is Alt-dash), Publisher only hyphenates it if the line break would be changed. If hyphenation isn't possible, Publisher disregards the soft hyphen. The soft hyphen becomes part of the file, and if you reformat your text so that hyphenation becomes possible, Publisher uses it.

One use for soft hyphenation is the case where, in justified text, one line is "open" (with a lot of space between words) and the following line is dense (little space between words). Such variations in text density can be visually displeasing. To even out the text density, you can place soft hyphens in the text.

**Note:** Soft hyphenation is possible in paragraphs where hyphenation has been turned off in the style sheet.

## Entering Tabs

To enter a tab in your document, switch to Text mode, place the cursor where you want the tab, and press the Tab key.

If your word processor saves tabs as a true tab character (ASCII decimal 9), you can enter tabs in your text file as you are writing it. You may need to experiment to see if you can do this with your word processor. Some—like WordStar in its document mode—save tabs as spaces.

**Note:** Publisher automatically converts any sequence of three or more consecutive blank spaces to a *single* tab stop.

## Text Blocks: Changing Text Style

In Text mode, you can use the mini-selector to change text style for a character or word, for a sentence *within* a paragraph, or for a whole paragraph when you don't want to reformat the global paragraph style. For example, in the latter case, you might want one paragraph of Body Text to appear in bold type, but not all Body Text paragraphs.

To assign a text style to a selected block, click on the style's name in the mini-selector.

To assign a combination of styles to the block (for example, to make text both bold and italic), click on each style name in the mini-selector.

To return a selected block to "normal" text (the text style specified for this paragraph style in the Character dialog), click on Normal in the mini-selector.

## Text Blocks: Embedded Style Codes

When you change text style in the manner just described, Publisher embeds codes at the beginning of the block to turn on the style and at the end of the block to turn off the style.

### Text Block Style Codes

<u>Code</u>	<u>Function</u>
<B>	Turns on boldface.
<I>	Turns on italics.
<U>	Turns on underline.
<N>	Turns off <B>, <I>, <U>, or any combination, and returns the style to the current attributes as defined in the document's style sheet. For example, in a paragraph whose style sheet character attribute is bold type, the <I> code changes the text from bold to bold italic, and the <N> code changes it back to bold.
<S#>	(# is a number.) Turns on a type size. Publisher inserts this code when you change the point size of a marked block.
<SN>	Turns off the type size.
<C#>	Turns on a text color. Publisher inserts this code when you change the color of a marked block.
<CN>	Turns off the text color.
<F#>	Turns on a font. Publisher inserts this code when you change the font of a marked block.
<FN>	Turns off the font.

Here's one example of how the codes work: This line in a text file:

**This is <B>bold<N> text.**

produces this on the screen and in output:

**This is bold text.**

You can embed the codes in your text file as you're writing it, but if you do, remember that codes must be in uppercase letters and must appear at both ends of the text block. The first code turns the style on; the second code turns the style off. The one exception is where the block ends at the end of a paragraph. In that case you don't need to turn the style off; Publisher does it automatically.

Here are a couple of other things to remember about the codes:

- To combine styles, combine codes in one set of angle brackets. For example, to turn on boldface, underline, and italics at the same time, use <BUI>, not <B><U><I>.
- The end of a paragraph automatically turns off text block styles. Publisher only uses the <N>, <SN>, <CN>, and <FN> codes to turn off styles within a paragraph. For that reason, if a marked text block extends over more than one paragraph, the appropriate code or code combination appears at the beginning of each new paragraph.
- To use any of the codes as literal strings in your text file (for example, if you're itemizing a list <A>, <B>, <C>, etc.), use two initial angle-brackets (<<). If you don't, Publisher will treat them as text style codes.

### **Text Blocks: Changing Fonts, Sizes, and Colors**

You can also use the Character dialog to change attributes for a selected text block. (To display the dialog, choose the **Character** command from the Style Menu.) In addition to changing the text style, the dialog makes it possible for you to change fonts, text sizes, and colors.

## Cutting, Copying, and Pasting Text

Publisher offers two related text block operations: cut-and-paste and copy-and-paste. Cut and copied text blocks are kept in a “paste buffer” in the CLIPBRD folder, described in Section 8.

Before cutting or copying a block, you must mark it, as described earlier in this section.

**Note:** Cutting or copying a text block overwrites any other text block in CLIPBRD, but it has no effect on rectangles in CLIPBRD.

### Cutting Text Blocks

To cut a marked block, display the Edit Menu and choose the Cut command. Cutting removes the block from the work area and places it in CLIPBRD. You can use cut-and-paste to do either of the following:

- Move a text block from one place to another in the document.
- Delete a marked block. (If you don't paste the cut block back into the document, you have effectively deleted it.)

### Copying Text Blocks

To copy a marked block, display the Edit Menu and choose the Copy command. The original block remains in the work area, but a copy of it is now in the CLIPBRD folder. You can insert the copy elsewhere in the document.

Copy-and-paste is useful, for example, if you want the same paragraph, with slight variations, to appear several times in a document. You can copy it once and then paste it into the document, editing the variations as you go along.



## Pasting Text

To paste a text block, switch to Text mode and do the following:

1. Move the I-beam to where you want the text block, and click. The text cursor appears where you clicked. If the cursor isn't in the right place, try again with the I-beam.

Note that you can only paste text into a text rectangle. You can't paste it into a graphics rectangle or into a part of the work area where there isn't any rectangle.

2. Display the Edit Menu and choose the **Paste** command. The block appears where the text cursor was, and Publisher reformats the document.

You can paste a block from the CLIPBRD folder as many times as you want; it makes no difference if you initially cut or copied the block to CLIPBRD.

## Bullets and Numbers

Creating bulleted and numbered lists in Publisher involves the same basic steps, combining a special paragraph style with the bullet character or number.

The first step is to create a paragraph style for the bulleted or numbered text. This paragraph style combines a positive Left Indent value (the left margin of the bulleted or numbered text), a *negative* First Line Indent (the position of the bullet or number), and a special tab setting. The illustration on the next page shows two bulleted paragraphs.

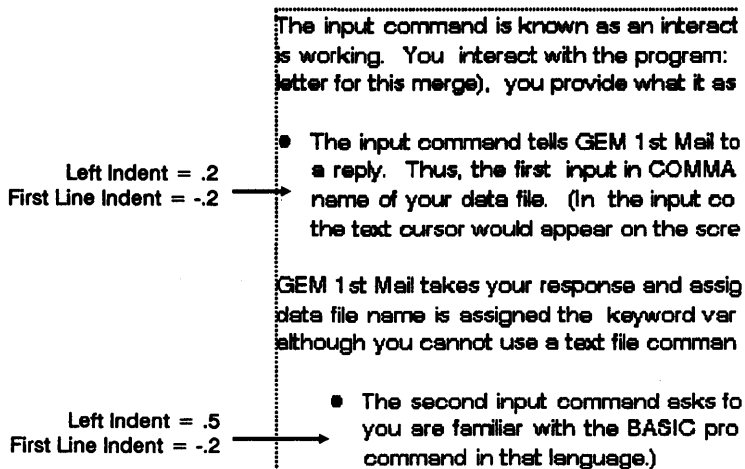

In the first bulleted paragraph, the bullet is aligned with the Body Text. To create this paragraph style, do the following:

- Use the **Paragraph** command to set the Left Indent value to **.2**, enough to make room for the bullet.

Set the First Line Indent to **-.2**, which will bring the bullet back to the same left indent as the Body Text.

- Use the **Paragraph Tabs** command to set the first tab stop to zero. To do so, press **Esc** to clear the first tab stop field, and then type **0**. You must enter a zero in this field; you cannot simply leave it blank.

**Note:** For any bullet or number paragraph style, the first tab stop value *must be zero*. As you'll see in a moment, this ensures that the text in the first line is aligned properly with the rest of the text in the paragraph.

Having created the paragraph style, you switch to Text mode and do the following:

1. Place the cursor at the beginning of the first line of the bulleted paragraph.
2. Type Alt-195. This inserts the bullet character.
3. Without moving the cursor, press the Tab key. This makes the first line align itself with the rest of the paragraph. Why? Because tabs are measured from the Left Indent, and the first tab stop value is zero. As a result, the first tab stop position and the Left Indent are the same.

The second bulleted paragraph was created in much the same way, except that the Left Indent is .5, so that the whole paragraph is indented from the Body Text. The First Line Indent value is still - .2.

The paragraph style for numbered paragraphs is created in the same way. The only difference is that, instead of typing a bullet character, you type the number.

As was noted in "Entering Special Characters," earlier in this section, you can type the bullet character (Alt-195) and the tab into your text file as you are writing it. If you have a style sheet with the bullet paragraph style, the bulleted paragraphs are instantly formatted when you bring the text file into your Publisher rectangle.

## Text Rectangle Attributes

When you choose the **Rectangle** command with a text rectangle selected, Publisher displays the Text Rectangle dialog.

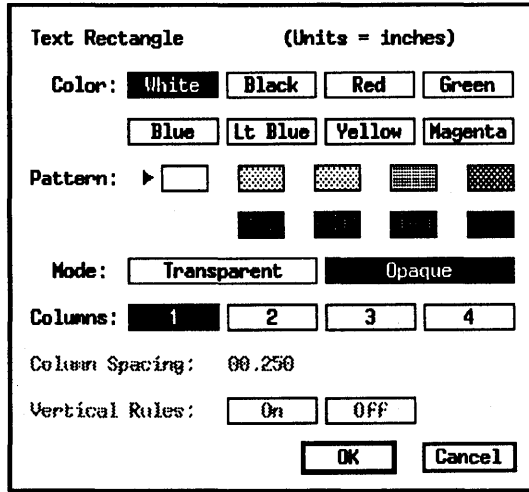

Use this dialog to set the attributes of the text rectangle.

- Color** Selects the background color for the rectangle. The default color is White (no background color).
- Pattern** Selects a fill pattern for the rectangle. In most situations the fill pattern is not visible until you choose a color other than white. The default pattern is no pattern.
- Mode** When rectangles overlap each another, determines whether anything shows through from the rectangle underneath. Modes are meaningful only when assigned to the rectangle on top. There are two modes, Opaque (the default) and Transparent.

**Opaque:** The covered part of the bottom rectangle is not visible. In Opaque mode, text flows around the top rectangle.

**Transparent :** The rectangle underneath is fully visible. When a transparent rectangle overlies a text rectangle, the text underneath *does not flow* around the rectangle on top.

The illustration below shows the difference between Opaque and Transparent mode.

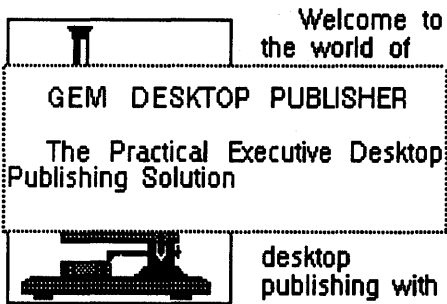

opaque text

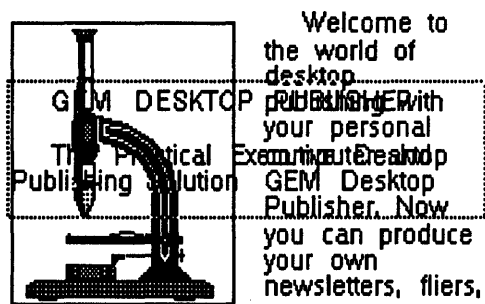

transparent text

**Columns** Lets you format the text in 1, 2, 3, or 4 columns.

### Column Spacing

Lets you set the space between columns of multi-column text. To enter a value in this field, press the Esc key to clear it, and type a number.

**Vertical Rules** Lets you draw a vertical line between each column of multi-column text.

**Note:** Column settings are a rectangle attribute, not a paragraph attribute. They are saved as part of the document, *not* as part of a style sheet.

---

# Graphics

**G**EM Desktop Publisher has two ways in which you can add graphics to your documents:

- You can “import” graphics created with other programs.
- You can create graphics with Publisher’s own graphics elements.

## Importing Graphics

Just as you can insert a text file into a rectangle, you can also insert a graphics file into a rectangle. Publisher accepts graphics files in the .GEM and .IMG formats, created by GEM applications as well as files created with other applications that have been converted to either of those formats.

.GEM files are created by applications like GEM Presentation Team, GEM Draw Plus, GEM Artline, GEM Graph, and GEM WordChart; .IMG files are created by applications like GEM Paint and GEM Scan.

## Bringing Graphics into a Rectangle

The first step in importing graphics is to switch to Rectangle mode and draw a rectangle in the work area. If the rectangle anywhere overlaps a text rectangle, Publisher automatically makes the text “flow” around the new rectangle.

To bring graphics into the rectangle, follow these steps:

1. Make sure the rectangle into which you’ll import the graphics is selected. You can tell by the handles at its corners. If the rectangle is not selected, switch to Select mode and click on the rectangle.
2. Set the file extension and path in the mini-selector so you can get at your graphics file.

First, click on the file extension indicator in the mini-selector until it reads **\*.GEM** or **\*.IMG**, depending on which kind of file you want to import.

Next, using the close box and/or folder names, change the path in the mini-selector until it shows the path containing your graphics file.

Appendix D describes the mini-selector in detail.

3. Click on the name of the graphics file in the mini-selector window. (If need be, scroll the mini-selector window to bring the name into view.)

Publisher reads the graphics file into your rectangle.

**Note:** For simplicity’s sake, we’ll use “picture” in this section to refer to any graphics file (.GEM or .IMG) unless the difference between the formats is significant.

Initially the entire picture is made to fit in the rectangle, usually by being made larger or smaller and by being centered vertically or horizontally. This “Best Fit” option is one of several rectangle attributes you can set.

## Rectangle Attributes

When you choose the **Rectangle** command when a graphics rectangle is selected, Publisher displays the Graphics Rectangle dialog.

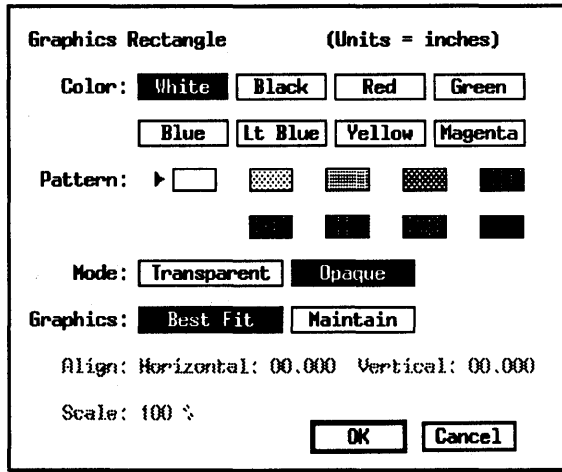

Use the Graphics Rectangle dialog to set the attributes of your graphics rectangle.

- Color** Selects the background color for the rectangle. The default color is *White* (no background color).
- Pattern** Selects a fill pattern for the rectangle. In most situations the fill pattern is not visible until you choose a color other than white. The default pattern is no pattern.



In a graphics rectangle, the background color and pattern do not show through a *solid* element, like a GEM Draw Plus polygon with a fill pattern. The microphone in the illustrations below was created with GEM Draw Plus, and the polygons all have a solid fill pattern.

In images files, like the pointing hand below, the background color and pattern do not show through the image's rectangular "extent" when the graphics rectangle is in Opaque mode. The color and pattern do show through when the rectangle is in Transparent mode. Opaque mode and Transparent mode are described next.

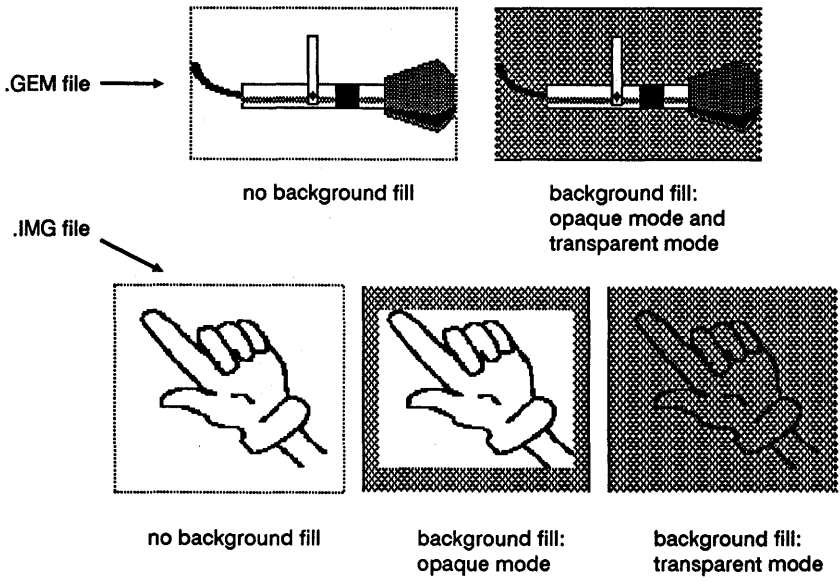

**Mode**

When rectangles overlap each another, determines whether anything shows through from the rectangle underneath. Modes are meaningful only when assigned to the rectangle on top. There are two modes, Opaque (the default) and Transparent.

**Opaque:** The covered part of the bottom rectangle is not visible. In Opaque mode, text flows around the top rectangle.

**Transparent:** The rectangle underneath is fully visible, except where the top rectangle contains solid elements or if the top rectangle has a solid background. When a transparent rectangle overlies a text rectangle, the text underneath *does not flow* around the rectangle on top.

"Fitting Text to Graphics," in Appendix B, describes one use of Transparent mode.

The following illustrations show the difference between Opaque mode and Transparent mode.

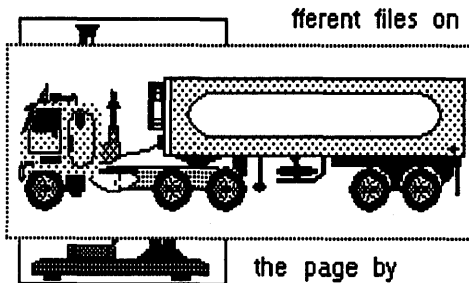

Opaque graphics

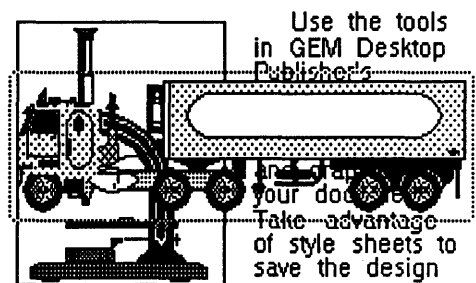

Transparent graphics

- Graphics** Lets you fit the picture to the rectangle or maintain the picture's original size.
- "Best Fit"** Fits the *entire* picture to the rectangle, making the picture larger or smaller as necessary. In Best Fit, the picture is also centered in the rectangle.
- "Best Fit"** is the default setting for all rectangles except headers. (See the discussion of the **Make Header** command in Section 9.)
- "Maintain"** Allows you to control the size of the picture in the rectangle. This option makes available two important features: *scaling* and *alignment*.
- Scaling** "Scaling" refers to the size of the picture in the Publisher rectangle relative to its size in the original .GEM or .IMG file. Initially, when you choose the Maintain option, the picture is the same size as the original; it is scaled at 100%. If the rectangle is not as big as the picture, you only see part of the picture. To see more of the picture, you can make the rectangle larger or make the picture smaller. To do the former, you drag one of the rectangle's handles; to do the latter, you change the Scale factor—for example, to 75%.
- Scaling makes it possible for you to maintain the relative size of different pictures. For example, if picture B is twice as big as picture A and you scale both to 50%, picture B is still twice as big as picture A, although both are now half their original sizes.

The figures on this page and the next page illustrate Best Fit and Maintain and the alignment option.

The first picture below shows a drawing made in GEM Draw Plus. Regardless of its shape or how many elements it contains, a picture or image file can always be enclosed within a rectangle. GEM Draw Plus uses the term "extents" for this rectangle and the small boxes at the corners and sides; we'll use that term also. The second picture shows the drawing in a Publisher rectangle with the Best Fit option. Because the rectangle is smaller than the picture's original extents, the picture has been centered and made smaller to fit the rectangle. The third picture shows the drawing with the Maintain option, scaled at 100%.

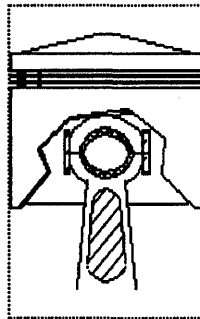
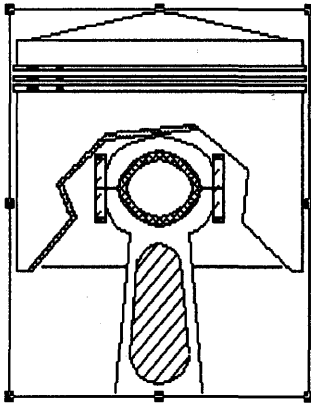

Best Fit

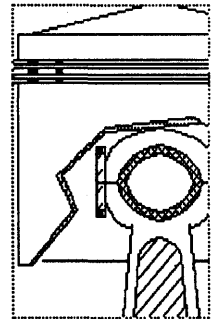

Maintain

**Alignment**

The Align option allows you to move the picture in the graphics rectangle, as illustrated by the figures below.

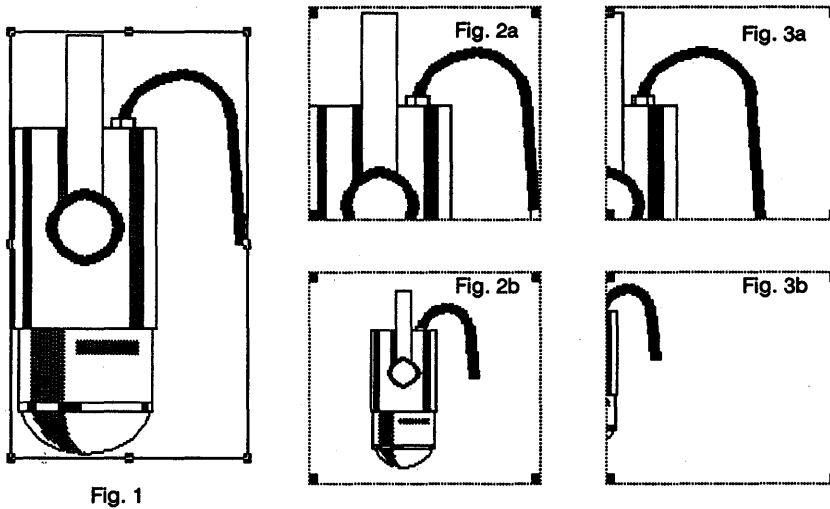

Fig. 1 shows another picture from GEM Draw Plus. Fig. 2a shows the picture scaled at 100% in a Publisher rectangle smaller than the original extents. The upper left corner of the picture is in the upper left corner of the rectangle. Fig. 2b shows the picture in the same rectangle, scaled at 50%. The picture is centered in the rectangle. In both Fig. 2a and Fig. 2b, the horizontal and vertical alignment values are zero.

Fig. 3a and Fig. 3b show the pictures with a horizontal alignment value. Both pictures have shifted to the left in the rectangle, but in Fig. 3b the picture has also shifted *up* in the rectangle. Here's why:

If either alignment value is something other than zero—in other words, if there is any horizontal or vertical alignment—both values are treated as coordinates measured from the upper left corner of the picture's extents.

For example, let's say you entered these values in the Graphics Rectangle dialog:

Graphics:	<input type="checkbox"/> Best Fit	<input checked="" type="checkbox"/> Maintain
Align:	Horizontal: .25_	Vertical: 00.000
Scale:	50_ %	
	<input type="button" value="OK"/>	<input type="button" value="Cancel"/>

Using these values, Publisher places the left edge of the rectangle .25 inch in from the left edge of the extents. Because the vertical alignment value is zero, the top of the extents is matched to the top of the rectangle. The illustration below shows how the horizontal alignment moves the picture in the rectangle.

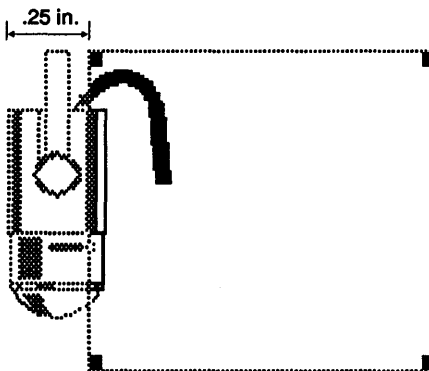

**Note:** Publisher does not accept horizontal or vertical alignment values that would push the picture completely out of the rectangle. If you enter such a number, Publisher displays an alert and automatically resets the value to zero.

## Graphics Elements

Publisher's graphics elements make it possible for you to enhance your documents with a variety of designs—rectangles, rounded rectangles, circles, and lines with a variety of colors, fill patterns, and other styles.

### Graphics Mode

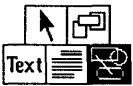

The graphics elements—rectangle, rounded rectangle, circle, and line—are available in Publisher's Graphics mode. To switch to Graphics mode, click on its icon in the toolkit.

Graphics elements are always "attached" to a text or graphics rectangle. Before switching to Graphics mode, select the rectangle to which you want the graphics element attached. If you don't select a rectangle, Publisher makes the selection for you:

- If there is one rectangle on the current page and it is not selected, Publisher selects it.
- If there is more than one *selected* rectangle on the current page, Publisher automatically selects the rectangle on the bottom. See the discussion of "Rectangle Layers" in Appendix B.
- If there are several rectangles on the page and none is selected, Publisher again selects the bottom rectangle.

If there are no rectangles on the current page, you cannot draw graphics elements.

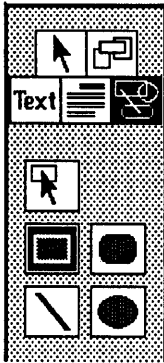

To draw a graphics element:

1. Switch to Graphics mode. Publisher displays the graphics elements icons in place of the mini-selector.
2. Click on the icon for the graphics element you want to draw.
3. Move the pointer into the work area, and drag with the mouse to draw a rectangle, rounded rectangle, circle, or line.

When you finish drawing a graphics element, its icon remains highlighted so you can draw more elements. To move an element or change its size, you must first click

on the Graphics mode select icon, just above the four element icons. You can then select the element and move it or change it.

Graphics elements have several important characteristics:

- They are always on top of the rectangle to which they are attached.
- When you move or cut a rectangle, you move or cut any graphics elements attached to it.
- If you attach graphics elements to a text rectangle that repeats over several pages, the graphics elements also repeat.
- Text in text rectangles does *not* flow around graphics elements. To make the text flow around a graphics element, switch to Rectangle mode, add a rectangle where you will put the graphics element, and then draw the graphics element. The underlying rectangle forces the text to flow around the graphics element.
- You can cut, copy, and paste graphics elements.



## Fill Attributes

To change the color, fill pattern, or mode of a rectangle, rounded rectangle, or circle graphics element, choose the **Fill Attributes** command from the Attributes Menu. These attributes are the same as those described under "Rectangle Attributes" earlier in this section.

To preset your fill attributes, switch to graphics select mode, de-select any selected graphics elements (click in the work area away from the element), and then choose the **Fill Attributes** command. The attributes you choose at this time will apply to any graphics elements you draw afterwards. The default fill is a solid black.

## Line Attributes

To change the width (thickness) or style (solid, dashed, etc.) of any line graphics element or the outline around a rectangle, rounded rectangle, or circle graphics element, choose the **Line Attributes** command from the Attributes Menu.

Here are a couple of things to remember about line attributes:

- The full set of line styles is only available for lines that use the default width. (The default width can vary according to what kind of printer you have.)
- To draw a rectangle or circle with no outline, set the Width to zero by pressing the Esc key.

The End Styles attribute makes it possible to draw lines that are squared, rounded, or have arrows at either end.

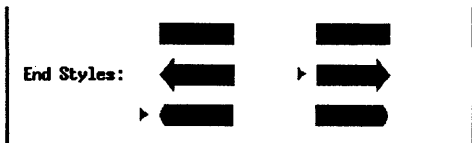

In the dialog, the column on the left determines the end style of the line at its *start* (rounded, in this case); the column on the right determines the end style of the line at its *finish* (an arrow). The selected style is indicated by a marker.

The illustration below shows two lines that would result from these settings in the Line Attributes dialog.

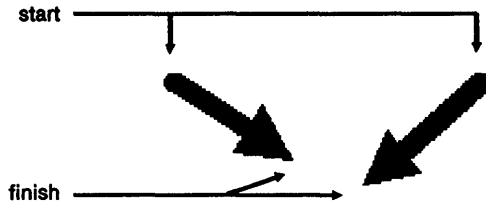

To preset your line attributes, switch to graphics select mode, de-select any selected graphics elements (click in the work area away from the element), and then choose the **Line Attributes** command. The attributes you choose at this time will apply to any graphics elements you draw afterwards.



---

# Menus

**T**he GEM Desktop Publisher menu bar contains the following menu titles: File, Edit, Style, Attributes, Page, Options, and PUBLISHR.

To choose a command from a menu:

1. Move the pointer to the menu's name in the menu bar. If you have set your menu drop-down preference to "No click," this automatically displays the menu. If your menu preference is set to "Click," you must click the mouse button to display the menu. These options are described in the *GEM/3 Desktop User's Guide*.
2. Move the pointer through the menu until the command you want is highlighted.
3. Click the mouse button.

## Keyboard Command Equivalents

Publisher offers you a shortcut way of choosing commands: In addition to using the menus, you can type a command code from the keyboard.

For example, in Publisher's default form, you can invoke the **New** command (in the File Menu) by typing **Ctrl-W** (holding down the Ctrl key while you type **W**, in upper or lower case) and the **Paragraph** command (in the Style Menu) by typing **Alt-2**.

The shortcuts are listed in the menus, using the following notation:

- A caret (^) represents the Ctrl key.
- A diamond (◆) represents the Alt key.
- An up-arrow (↑) represents the Shift key.

If a command is not available at the moment, its keyboard equivalent has no effect either. For example, the **Paste** command is not available if there's nothing in the CLIPBRD folder; there's nothing to paste. Unavailable commands are dimmed ("grayed out") in the menus.

## File Menu

File	
New	^N
Open...	^O
.....	
Save	^V
Save as...	^M
Abandon	^A
.....	
To App...	
To Output	^U
Quit	^Q

**Note:** The keyboard equivalents in the illustrations are Publisher's defaults. Appendix A describes how you can make your own set of keyboard equivalents.

- New** Starts a new document in the active window.
- If there is a document in the window and you have saved all edits, Publisher clears the document from the screen and presents you with a clean page. The filename in the title bar becomes UNTITLED.GWD.
- Open** Displays the Item Selector so you can bring an existing document into the work area. (The Item Selector is described in detail in Appendix D.)
- See "A Note on Opening Documents" at the end of the description of this menu.
- Save** Saves the document in the work area. The Save command always saves the document to the name and path in the window's title bar, overwriting the existing document with the new version.

To save documents under different names or to a different path, use the **Save as**, described next.

Use the **Save** command at regular intervals during a Publisher session to guard against losing your edits to power failures, computer malfunctions, or other unforeseen calamities.

**Save as** Displays the Item Selector so you can save the document in the active window's work area under the name you supply. This is the command you use to name and save a document for the first time.

**Note:** Appendix D contains more information on saving documents.

**Abandon** Tells Publisher to throw out any changes you have made to your document and return to the last version you saved. If you haven't yet saved the document, **Abandon** returns you to an empty work area.

**To App** Displays the Item Selector so you can start another GEM application and edit the text or graphics in the currently selected rectangle of your Publisher document.

For example, let's say the selected rectangle contains a GEM Draw Plus file called PICTURE.GEM. If you double-click on DRAW.APP in the Item Selector directory window, you exit Publisher, and GEM Draw Plus is started with PICTURE.GEM in the work area.

If the rectangle contains a file called IMAGE.IMG and you double-click on PAINT.APP, GEM Paint is started with IMAGE.IMG in its work area.

If the rectangle contains a text file called TEXT.ASC and you double-click on WORDPLUS.APP, GEM 1st Word Plus is started with TEXT.ASC in the work area.

When you exit the application, you return to Publisher. The page you were on when you chose the **To App** command is again displayed in the work area.

If no rectangle is selected when you double-click on the filename, the application starts with an empty work area.

**To Output**

Starts the GEM Output program. Output is described in the tutorial (Section 4) and in the *GEM/3 Desktop User's Guide*.

In addition to directing your output to a printer, you can direct it to the screen. When you output to the screen, however, remember the following:

- Image files cannot be reproduced in screen output. Instead, they are represented by a shaded rectangle.
- If the document is more than one page long, you can display the second and any subsequent pages by pressing the Enter key or by setting the Screen Preferences to a time interval. Screen Preferences are described in the *GEM/3 Desktop User's Guide*.

**Quit**

Ends your Publisher work session. **Quit** returns you to the place from which you started Publisher, either the GEM Desktop or the operating system prompt.

## “Abandon/Save” Alert

If you have not saved your current edits when you choose the **New**, **Abandon**, **To App**, **To Output**, or **Quit** command, Publisher displays an alert that asks if you want to abandon or save the edited document. The alert gives you three options:

<b>Abandon</b>	You lose any edits made since the last time you saved the document.
<b>Save</b>	Publisher saves the document. If it already has a name, Publisher saves it under that name. If it is a new document, Publisher displays the Item Selector so you can name and save it for the first time. (See the descriptions of the <b>Save as</b> command and the Item Selector.)
<b>Cancel</b>	Publisher disregards the command.

## A Note on Opening Documents

When you open a document, Publisher “remembers” how things were when you last saved the document. When the document is loaded into memory, it brings the following with it:

- style sheet
- page orientation (Portrait/Landscape)
- image size (for example, 8 x 10 or 8 x 13)
- unit of measure of the image (inches/centimeters)
- grid size (the space between grid points)

In addition, the default path and file extension in the mini-selector and Item Selector are set to where they were when you saved the document. Finally, the document is opened to the page you were on when you saved it.

See “Missing Source Files” in Appendix C for a discussion of what happens if any of the document’s files are missing.



## Edit Menu

Edit	
Cut	↵D
Copy	↵C
Paste	↵U
.....	
Empty Rectangle	
Center Rectangle	
.....	
Select All	↵S
Make Header	↵H

**Cut** Cuts *selected* rectangles, graphics elements, or a block of text to the CLIPBRD folder (described on the next page). The rectangles, elements, or block are removed from the work area.

**Copy** Copies *selected* rectangles, graphics elements, or a block of text to the CLIPBRD folder. The original rectangles, elements, or block remain in the work area.

**Paste** Pastes rectangles, graphics elements, or a block of text from the CLIPBRD folder into the work area on the current page.

### Empty Rectangle

Removes the text or graphics from the currently selected rectangle, leaving an empty rectangle. Removes all graphics elements attached to the rectangle.

### Center Rectangle

Centers the currently selected rectangle or group of rectangles *horizontally* on the page.

- Select All** In Rectangle and Select modes, selects all rectangles on the current page. In Paragraph mode, selects all paragraphs on the current page. In Graphics mode, selects all graphics elements.
- Make Header** *For graphics rectangles only.* Makes the currently selected graphics rectangle a header or footer. See the discussion of headers and footers in Section 9.

## CLIPBRD Folder

When you cut or copy rectangles, graphics elements, or text, Publisher places it in a folder called CLIPBRD. (CLIPBRD is created by the GEM Setup program discussed in Section 2.)

CLIPBRD is "one level deep" for rectangles and text blocks; it can only hold one of each at a time. For example, if there is already a rectangle in CLIPBRD when you cut or copy one from your document, the first rectangle is deleted from the folder. Note, however, that cutting or copying a rectangle has no effect on text in CLIPBRD, and cutting or copying text has no effect on rectangles.

After you cut or copy a rectangle or text block to CLIPBRD, you can paste it into the document as often as you want. In that sense, CLIPBRD is like the paste buffer in a word processing application.

**Note:** When you quit Publisher, any *rectangle* (graphics or text) in the CLIPBRD folder is automatically deleted, but a *text block* in CLIPBRD is saved as a standard ASCII file with the filename SCRAP.ASC. To paste SCRAP.ASC into a document, switch to Text mode, click the I-beam where you want the text to appear, and choose the Paste command from the Edit Menu.

## Pasting Rectangles and Graphics Elements

To paste rectangles into your document from the CLIPBRD folder, switch to Select or Rectangle mode and then choose the Paste command from the Edit Menu. To paste graphics elements into the document, select the rectangle to which you want them attached, switch to Graphics mode, and choose the Paste command.

Publisher pastes the rectangles or graphics elements into the current page *in the same location that it occupied on the page from which you cut or copied it.*

If you *copy* a rectangle and then paste it back onto the same page, it appears on top of the original rectangle. You can then drag it to another part of the page.

When Publisher is in 2 PG view, it always pastes rectangles and text blocks into the current page identified in the window's title bar. To make the other page current, simply click in it.

Cutting/copying and pasting is the only way you can move or copy a rectangle from one page to another.

## Text

Cutting, copying, and pasting text blocks are described in Section 6 under "Marking Text Blocks" and "Cutting, Copying, and Pasting Text."

## Style Menu

Style	
Get Style Sheet...	◆6
Save Style Sheet...	◆7
.....	
Copy Para Style...	◆8
Delete Para Style...	◆9

### Get Style Sheet

Displays the Item Selector so you can select a style sheet for your document. See the discussion of style sheets in Section 5.

### Save Style Sheet

Displays the Item Selector so you can name and save the current style sheet for your document. See the discussion of style sheets in Section 5.

### Copy Para Style

*Paragraph mode only.* Displays a dialog in which you enter a new paragraph style name. The new style takes the attributes of an existing paragraph style, either the currently selected paragraph or one you name in the dialog. See the discussion of style sheets in Section 5.

### Delete Para Style

*Paragraph mode only.* Displays a dialog with which you can delete the currently selected paragraph style or any other style except Body Text. All text with the attributes of the deleted paragraph style reverts to Body Text. See the discussion of style sheets in Section 5.

## Attributes Menu

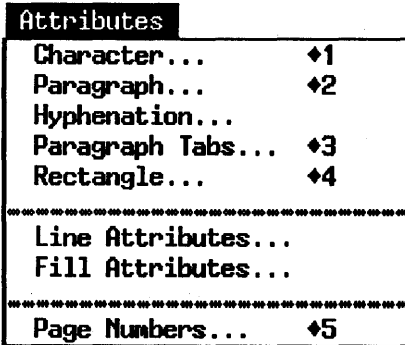

**Character**     *Paragraph mode.* Displays a dialog in which you can format the character attributes—font, style (Bold, Italic, or Bold Italic), point size, and text color—of the current paragraph style.

*Text mode.* Displays the same dialog so you can format the character attributes (including kerning) of a selected block of text.

For a full discussion of this dialog, see Section 5.

**Paragraph**     *Paragraph mode only.* Displays a dialog in which you can format the paragraph attributes—indents, line spacing, tracking, and alignment—of the current paragraph style.

For a full discussion of this dialog, see Section 5.

**Hyphenation**     *Paragraph mode only.* Displays a dialog in which you can turn on hyphenation for the current paragraph style.

For a full discussion of this dialog, see Section 5.

**Paragraph Tabs**

*Paragraph mode only.* Displays a dialog in which you can set the tab stops for the current paragraph style. Stops are set according to the unit of measure in the ruler, and are aligned to the left, right, center, or by decimal points, measured from the Left Indent value of the paragraph style.

For a full discussion of this dialog, see Section 5.

**Rectangle**

*Rectangle and Select mode only.* Displays a dialog in which you can set the attributes of a text or graphics rectangle. Text rectangle attributes are described in Section 6; graphics rectangle attributes are described in Section 7. The **Rectangle** command is only available in Select and Rectangle modes, and only when a text or graphics (.GEM or .IMG, not one created in Publisher's Graphics mode) rectangle is selected.

**Line Attributes**

*Graphics mode only.* Displays a dialog in which you can set the color, type (solid, dotted, dashed, or dot-dash), end styles, and width of lines drawn in Publisher's Graphics mode. Line attributes also apply to the outlines of rectangles, rounded rectangles, and circles drawn in Graphics mode. These attributes are described in Section 7.

**Fill Attributes**

*Graphics mode only.* Displays a dialog in which you can set the fill attributes of a rectangle created with Publisher's Graphics mode. These attributes are described in Section 7.

**Page Numbers** Displays a dialog in which you can choose the format of your page numbers: letters, Arabic numerals, or Roman numerals. See the description of the **Make Header** command (Edit Menu) and the description of headers and footers in Section 9.

You can also use this dialog to specify the number of the first page of your document. The default page number is 1, but you can start with any page number up to and including 99.

## Page Menu

Page	
Hide Graphics	◆F1
Show Position	◆F2
Show Size	◆F3
Hide Toolkit	◆F4
Ruler in Picas	◆F5
Landscape	◆F6
Auto Grid Off	◆F7
.....	
Go to Page...	◆F8
Insert Page	◆F9
Delete Page	◆F10
.....	
Image Size...	F4
Grid Size...	F2

### Hide Graphics/Show Graphics

Changes the contents of all graphics rectangles from the actual picture to a shaded rectangle. The rectangle contains the directory path information for the graphics file. Hiding graphics considerably speeds up Publisher's screen drawing time for image (.IMG) files.

Hiding graphics does not affect the appearance of your document in output.

This command is a toggle. When graphics are hidden, the command changes to **Show Graphics**.

**Show Position** *Select, Rectangle, and Graphics mode.* Publisher displays the coordinates of the position of the cross hair or pointer in the work area. The coordinates are given in the current unit of measure (inches, centimeters, or picas) and are always calculated from a [0,0] at the upper



left corner of the *page* (not the work area--in Norm or 2x view, the upper left corner of the page is not visible in the work area if you have scrolled the document).

A marker in the menu indicates when **Show Position** is in effect. To "turn off" **Show Position**, simply click on the command again.

### Show Size

*Select, Rectangle, and Graphics mode.* As you draw a rectangle, Publisher shows you its size by giving the coordinates of the cross hair, measured from the upper left corner of the rectangle. The coordinates are given in the current unit of measure (inches, centimeters, or picas).

In *Select mode*, Publisher displays the rectangle's size, in coordinate form, when you press the mouse button while the pointer is on any of the rectangle's handles.

A marker in the menu indicates when **Show Size** is in effect. To turn off **Show Size**, simply click on the command again.

**Note:** **Show Size** and **Show Position** are mutually exclusive; turning one on automatically turns off the other.

The figure below illustrates the difference between **Show Position** and **Show Size**.

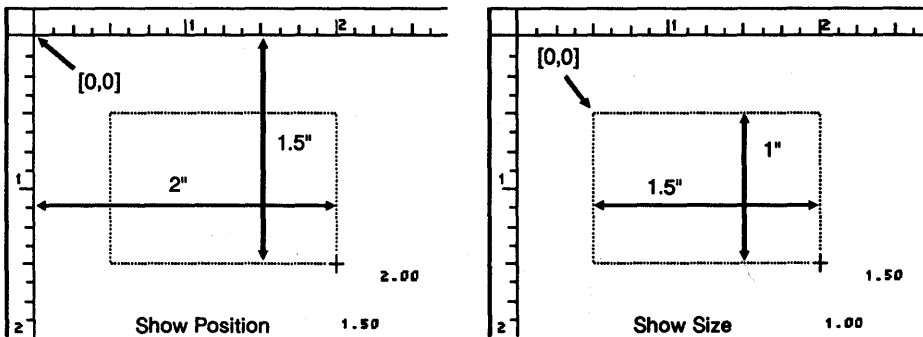

**Hide Toolkit/Show Toolkit**

Removes the toolkit from the screen, making the work area larger and allowing more of the page to be visible.

This command is a toggle. When the toolkit is hidden, the command changes to **Show Toolkit**.

**Rulers in Inches/Picas/Centimeters**

Toggles the ruler's unit of measure between Inches and Picas or, if you switch to a metric page with the **Image Size** command (described later in this menu), between Centimeters and Picas.

**Landscape/Portrait**

Toggles the page orientation between Landscape (a horizontally oriented page) and Portrait (a vertically oriented page). The default page orientation is Portrait; the default form of the command is its opposite, Landscape.

**Auto Grid Off/On**

Toggles Publisher's "auto grid" (or "grid snap") off and on. The default setting of the grid is On; the default form of the command is its opposite, **Auto Grid Off**.

The grid makes possible considerable precision and accuracy in the creation and alignment of rectangles. It is made up of the points of intersection of the ruler increments. For example, if the rulers are divided into quarter-inches, there is a grid point every quarter-inch in the work area. (The grid points are invisible; the work area isn't filled with little dots.)

When you are creating a new rectangle with the grid On, the cross hair always "snaps" to the nearest grid point. Similarly, if you move a rectangle, it always snaps to the nearest grid point.

When the grid is Off, there is no snap. Rectangles are exactly the size you make them, and they are located in exactly the place you create or move them.

**Go to Page** Displays a dialog in which you can enter a page number. Publisher then displays the page in the work area.

**Insert Page** Inserts a blank page immediately before the current page. This blank page then becomes the current page.  
To make the new page part of an existing document, do the following:

1. Add a rectangle to the page.
2. Click on the name of the document's text file in the mini-selector.

Publisher reformats the entire document, including the new page.

**Delete Page** Deletes the current page from your document. If the page contained text from a file spread over several pages, Publisher reformats the entire document.

**Image Size** Displays a dialog in which you can choose the following:

- The rulers' basic unit of measure, Inches or Centimeters. Note the effect of this choice on the **Rulers in Inches** command described previously.
- The size of the *image*, the full usable part of the page, including the margins enforced by a printer. With Inches as the rulers' unit of measure, Publisher supports two image sizes, 8 x 10 and 8 x 13. With Centimeters as the unit of measure, Publisher supports the A4 (17 x 25.7 cm.) and A3 (25.7 x 38 cm.) paper sizes.

For example, when an 8 x 10 image is printed on an 8 1/2 x 11 page, there is a 1/4-inch margin on each side of the page and a 1/2-inch margin at the top and bottom.

**Grid Size** Displays a dialog in which you choose the increment of the unit of measure for the rulers and the grid. For example, if the unit of measure is Inches and you choose 1/2, the ruler is divided into half-inch increments, and the grid points occur every half inch.

## Options Menu

Options	
Copy Document...	◆A
Copy Print Files...	◆P
.....	
Set Preferences...	◆V
Save Preferences	◆N
.....	
Hyphenate Word...	
Select Width Table...	
.....	
Status...	
Editing Shortcuts...	F1
Icon Shortcuts...	F3

### Copy Document

Allows you to copy a document and all its associated text and graphics files *to* another folder or disk or *from* another folder or disk.

Publisher embeds a lot of information in its document files, including path information telling it where to find the text files, style sheet, and graphics files in the document. For that reason, except for the case noted below, you *must* use **Copy Document**, not the GEM Desktop or operating system, to copy your documents. If you don't, you won't be able to open the copy of your document.

When you choose the **Copy Document** command, Publisher displays the Copy Document dialog, illustrated on the next page.

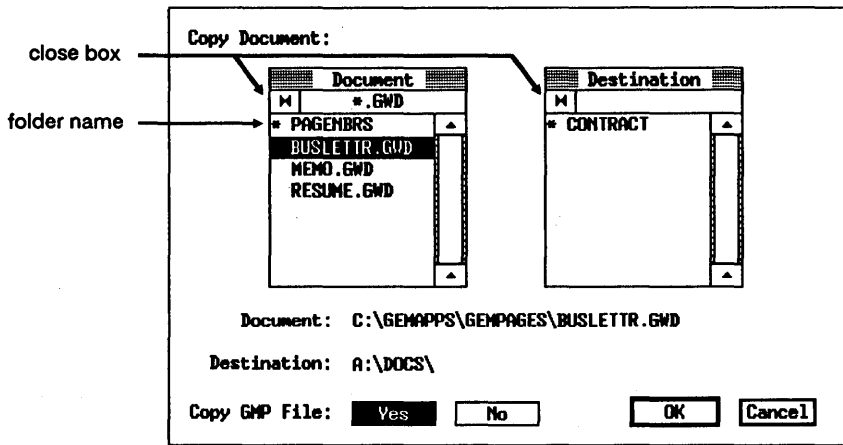

To select a document for copying, bring its name into the Document window and click on the name. Publisher copies the name and full path to the Document line below the window.

The Document window initially lists the files contained in the current folder, the one named in the main window's title bar. If need be, use the close box or folder names to change the path and bring the document name you want into the window. (This window works in much the same way as the Directory window of the Item Selector, described fully in Appendix D.)

Now choose the destination for the copy. As before, use the close box or folder names to change the path to the destination you want.

The illustration shows the Copy Document dialog after you have selected a file and its destination. In this case, the file BUSLETTR.GWD will be copied from the \GEMAPPS\GEMPAGES folder on the hard disk to the \DOCS folder on a floppy disk in drive A.

The dialog gives you the option of not copying the document's .GMP (output) file. Choose this option if the destination disk does not have room for the .GMP or if you want to save time in copying.

If you're copying to a floppy disk as a means of transferring a document from the hard disk on one computer to the hard disk on another computer, you must use **Copy Document** to copy the document from hard disk to floppy disk (the beginning of the journey) and from floppy disk to hard disk (the end of the journey).

**Note:** You cannot use **Copy Document** to copy a document directly from one floppy disk to another. Instead, use the GEM Desktop or operating system commands to copy files from floppy disk to floppy disk.

### **Copy Print Files**

Allows you to copy to another disk or directory the files required for printing a document. (The required files are the .GMP file and any .IMG files.)

The **Copy Print Files** command works in the same manner as the **Copy Document** command.

## Set Preferences

Displays the following dialog:

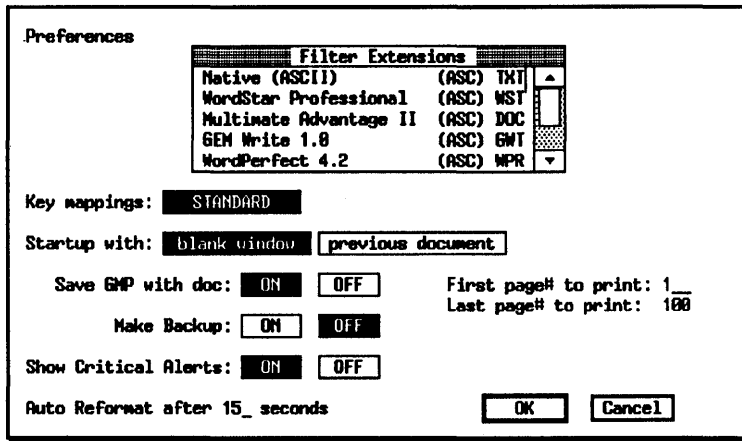

**Note:** The preferences set in this dialog remain in effect only through the current Publisher session, unless you choose the **Save Preferences** command.

### Filter Extensions

These are the file extensions that tell Publisher what word processor you used to create your text files. For example, in the default configuration, if your text file has a .TXT extension, Publisher assumes it is an ASCII file. If the file has a .WST extension, Publisher assumes it is a WordStar document mode file; if it has a .FWP extension, Publisher assumes it is a GEM 1st Word Plus file in WP mode.

Publisher uses these extensions to determine which file translation to perform on the file when creating the .ASC file that will be associated with the document. For more on these file translations, see "Filters" in Appendix A.



If you are not using the defaults, you can change the file extensions in the dialog. You can also use the Esc key to clear the file extension fields for word processors you don't use. This makes using the mini-selector faster because you don't have so many extensions to go through. See "Changing File Extension" in Appendix D.

You don't have to use the same extension for every file created with a particular word processor. For example, you could use a WordPerfect file with the default extension of .WPR in one rectangle, then draw a new rectangle, change the WordPerfect extension to .MEM, and read a WordPerfect file with the .MEM extension into the new rectangle.

**Note:** MultiMate, GEM 1st Word Plus, and GEM Write all create files with the .DOC file extension. However, because MultiMate requires the .DOC extension and the others allow other extensions, the Publisher defaults are .DOC for MultiMate, .FWP for GEM 1st Word Plus, and .GWT for GEM Write.

If you will not be using MultiMate but will be using GEM 1st Word Plus or GEM Write, and if you want to use the .DOC extension for your text files, clear the MultiMate extension field and change the GEM 1st Word Plus or GEM Write extension to .DOC.

See Appendix A for a description of Publisher's word processor support.

### **Key mappings**

Key mappings let you change the functionality of the keyboard and Publisher menus to match one of the supported word processors. See Appendix A for a full description of key mapping.

### Startup with

The preferences dialog gives you two choices of what is in the work area when you first start Publisher. The "blank window" option results in an empty work area; you can either start a new document or open an existing document. The "previous document" option starts Publisher exactly where you were when you quit your previous session. Publisher remembers and reproduces:

- the document in the work area, including its style sheet
- the mode you were in
- the current page for the document
- the view (Full, 2 PG, etc.) for the current page
- the size and location of the window

### Save GMP with doc

There are three reasons you might not want to save the .GMP (output) version of your document: doing so can be time-consuming for large documents, the file can take up a lot of disk space, and it isn't necessary until you are actually ready to print the document.

With that in mind, you can turn "Save GMP with doc" OFF. When you are ready to print the document, turn this option back ON just before you save the document.

### Make Backup

When you open, edit, and save a document with Make Backup set to On, Publisher makes backup copies of the document, its style sheet, and the ASCII version of its text file. The backups have the same filename; they are identified by a file extension whose last character is a dollar sign (.GW\$, .ST\$, .AS\$).

With Make Backup set to Off, Publisher replaces the original document with the new version when you save.

The backup feature is intended to give you a “fallback” in the event that you are unable to use your current version of the document. To use the backup files:

1. Quit Publisher and return to the GEM Desktop or the command line.
2. Delete the current document files (.GWD, .STL, and .ASC).
3. Rename the backup files from .GW\$ to .GWD, .ST\$ to .STL, and .AS\$ to .ASC.
4. Restart Publisher.

Making backup files has two consequences that might influence your choice of this preference:

- Saving documents is slower when a backup is being made.
- Backup files take up additional space on your hard disk or floppy disk.

### Show Critical Alerts

This option makes available an “expert” level of operation. When Show Critical Alerts is turned OFF, several of Publisher’s alerts (most notably the “Word too long” alert described in Appendix B) are suppressed, and the program runs with fewer interruptions.

### **Auto Reformat**

(Applies to *TEXT mode only*.) This option allows you to set how long Publisher waits for keyboard input before reformatting your text. For example, if you set the interval to ten seconds, Publisher automatically reformats the text if you haven't typed anything in ten seconds. You can set the interval to zero seconds (constant reformatting), but this will slow Publisher's performance noticeably. The default interval is fifteen seconds.

To set the interval, click on the number field, press Esc to clear the field, and enter a new number.

### **First/Last page# to print**

This option allows you to print one page or a range of pages from a document—for example, page 6 alone or pages 6 through 12. (To print a single page, set both values to the same page number.)

When you save a document after selecting a single page or a page range, Publisher creates a .GMP file that contains only the page or pages in the selected range. This .GMP file replaces any other .GMP file for the same document.

A selected page range applies to the .GMP file for any document you save. To print a different page range or to print the whole document, you must change this option before saving.

**Note:** You can also print a single page or a page range with the GEM Output program, even if the .GMP file is for the whole document. (See the description of the GLOBAL PREFERENCES dialog in the *GEM/3 Desktop User's Guide*.)

### Save Preferences

Saves the preferences set in the Preferences dialog. If you don't save them, the preferences only remain in effect through the current Publisher session.

In addition to saving the preferences named in the dialog, the **Save Preferences** command also saves the current state of the following:

- Graphics (Hide/Show)
- Show Position (on/off)
- Show Size (on/off)
- Toolkit (Hide/Show)
- Rulers in Picas/Inches
- Auto Grid (on/off)
- mode (Select/Rectangle/Text/Paragraph)
- view (2 PG/Full/Normal/2x)
- rulers (on/off)
- size of Publisher's window and its position on the screen
- portion of the page visible in the work area (i.e., position of the sliders)

When you save preferences, Publisher creates a file called PUBLISHR.INF in the GEMAPPS folder. To restore Publisher's default preferences (the preferences that Publisher comes with), return to the GEM Desktop or the command line and delete PUBLISHR.INF.

### Hyphenate Word

Displays the Hyphenation Exception Dictionary dialog, so you can add or delete special word hyphenations in the hyphenation exception dictionary. Hyphenation is described in detail in Section 5.

**Select Width Table**

Displays the Item Selector so you can select a new width table for your document. You might select a width table to gain access to certain fonts or to create a document specifically for a certain type of output device.

You can output successfully with any of the width tables provided, but the width table specifically for your printer will produce the best character spacing.

**Status**

Displays a dialog that gives the current status of your document: the number of files, pages, rectangles, and graphic elements that have been used, the number that are still free, and the total number available. The dialog also lists file buffer and disk drive status.

**Editing Shortcuts**

Displays a dialog listing the current text-editing and cursor control keystrokes. The keystrokes vary according to the key mapping currently in effect. Key mappings are discussed in Appendix A.

**Icon Shortcuts**

Displays a dialog listing the keystroke shortcuts you can use for the toolkit icons. For example, to switch to Rectangle mode, you can press Shift-F2. To select something from the mini-selector, you can press Ctrl and the function key whose number corresponds to the line in the mini-selector window on which the item appears. Thus, to select the third item, you press Ctrl-F3.

The keystrokes vary according to the key mapping currently in effect.

## PUBLISHR Menu

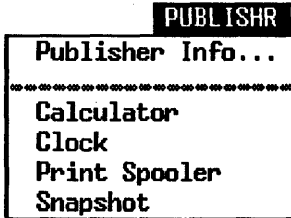

**Publisher Info** Displays an informational dialog that includes the version number of your copy of Publisher.

### Desk accessory names

Starts the specified desk accessory.

## Desk Accessories and System Memory

The PUBLISHR Menu can list a variety of desk accessories, including the Calculator, Clock, Snapshot, and Print Spooler. Because desk accessories take up space in your computer's memory, they can make applications like Publisher run more slowly. To avoid any loss of performance, you can free up memory by disabling any desk accessories you don't plan to use. Here are the steps:

1. Go to the GEM Desktop.
2. Open the GEMBOOT folder. The files for the desk accessories have a .ACC file extension: SNAPSHOT.ACC, for example.
3. Using the Info/Rename command, change the file extension of the accessories you want to disable to something meaningless, like SNAPSHOT.ACX. (Note that the calculator, clock, and print spooler are all contained in a single file called CALCLOCK.ACC.)

4. Exit the GEM Desktop to the operating system and then restart the GEM Desktop. The names of the disabled desk accessories will no longer appear in the DESKTOP or PUBLISHR Menu.

To restore the desk accessories, simply change the file extensions back to .ACC. Remember that you must exit and restart the GEM Desktop for the restored desk accessories to appear in the menu.

**Note:** You can also disable and restore desk accessories from the command line. Your operating system user's guide explains how you change directories and describes the REN (Rename) command.





---

# Headers and Footers

**H**eaders (sometimes called “running heads”) appear at the top of each page of a document. A typical header might have the document’s title above a line known as a rule, which extends from margin to margin. Headers can alternate the title from left to right for even- and odd-numbered pages.

Footers appear at the bottom of the page. The most common footer is a page number, but footers can also include dates or statements of ownership like “This material proprietary to XXX Corp.” Like headers, footers can alternate from left to right on the page.

**Note:** As far as Publisher is concerned, headers and footers are the *same thing*; they’re just on different parts of the page. The steps for creating headers and footers are identical, and the command is called **Make Header**. For that reason, the remainder of this section only uses the term “header.” (In fact, you can put headers anywhere on the page, not just at the top or bottom.)

## Headers as Graphics Files

Headers in GEM Desktop Publisher are actually *graphics files* created with GEM Draw Plus, GEM Artline, or any application that produces a .GEM-format file. Using graphics files makes it possible for you to combine text with a non-text design like a rule or a company logo.

You can use headers in a number of ways, not just to put a document title and page number at the top and bottom of your page. For example, you can use the **Make Header** command to cause *any* graphics file (like a design or letterhead) to repeat throughout a document.

## Page Number Files

Several sample page number files are included in the PAGENBRS folder, located inside the GEMPAGES folder. Their filenames (PNC07001.GEM, PNL07004.GEM, etc.) use the following codes:

<b>PNC</b>	Page Number, Centered
<b>PNL</b>	Page Number, Left-Adjusted
<b>PNR</b>	Page Number, Right-Adjusted
<b>07</b>	7 inches wide
<b>001</b>	the number of the file in its group

If you create header files of your own, you can give them any name you find useful.

## Creating Headers

The page number files give a good idea of how a simple header is created. Look at one or two of them in GEM Draw Plus before you create your own. When you're ready to go ahead, first design the header in your mind. Know what font, type style, and type size you want to use, as well as the width of the text rectangle it will accompany.

Each header should have a background rectangle to help locate it within the graphics rectangle in Publisher. As you create the header in GEM Draw Plus, keep these rules in mind:

- The background rectangle should have the solid white fill pattern and the "None" line style. (You can see this rectangle in the page number files by choosing the **Select All** command in GEM Draw Plus. The illustration under "Putting All Your Headers in One File," later in this section, shows the background rectangle. The background rectangle accounts for the large extents around the two page number headers.)

- Make the rectangle the same width as the header. In other words, if the header is four inches wide, the background rectangle should also be four inches wide. If the header contains only text, but contains one of the header codes described later in this section (for example, just a date or a page number, but no rule or other design), make the background rectangle wider than the text. This allows for variations in the length of the final header. For example, a date header's rectangle should be big enough to accommodate both May 1, 1987 and September 30, 1987.
- Center, right-align, or left-align the header in the background rectangle, and then use the **Make Group** command before you save the header file.

## Adding a Header to Your Document

When adding headers, make sure you do it from the first page on which you want the headers to appear, *before* you press PgDn to display the next page. Publisher will then automatically treat the rectangle as a header on each succeeding page.

If you go past the page at which you wanted to start your headers, you can go back and add the header rectangles later, but you'll have to **Make Header** for each one individually.

To add a header to a document:

1. Create a rectangle for the header. The **Show Size** command or the rulers can help you make sure the rectangle is the same width as the header you're bringing in.
2. In the mini-selector, click on the file extension indicator until it reads **\*.GEM**. Then click on the header's filename in the mini-selector window.

3. With the header rectangle selected, display the Edit Menu and choose the **Make Header** command. **Make Header** causes the header to repeat on subsequent pages and also switches the rectangle to the **Maintain** graphics option. (See "Rectangle Attributes" in Section 7.)

The **Maintain** option has two important effects on the header rectangle:

- It causes the header to appear in its true size. A 5-inch header is now exactly five inches wide.
- It ensures that header text appears in its true size. For example, 10-point text in the header is now the same size as 10-point Body Text.

## Header Codes

Publisher recognizes several codes in headers and translates them to the date, time, or a page number. You insert the codes when you create the header in GEM Draw Plus, and the actual translation takes place when you choose the **Make Header** command in Publisher. For example, the code **<\$page>** is translated to the current page number.

The table on the next page describes the codes.

## Header Codes

Code	Example	Description
<code>&lt;\$page&gt;</code>	5	page number
<code>&lt;\$lastpage&gt;</code>	26	last page of current sequence
<code>&lt;\$dateFUSA&gt;</code>	May 6, 1987	Full American-style date
<code>&lt;\$dateSUSA&gt;</code>	5/6/87	Short American-style date
<code>&lt;\$dateMUSA&gt;</code>	05/06/87	Medium American-style date
<code>&lt;\$dateLUSA&gt;</code>	05/06/1987	Long American-style date
<code>&lt;\$dateFEUR&gt;</code>	6 May, 1987	Full European-style date
<code>&lt;\$dateSEUR&gt;</code>	6/5/87	Short European-style date
<code>&lt;\$dateMEUR&gt;</code>	06/05/87	Medium European-style date
<code>&lt;\$dateLEUR&gt;</code>	06/05/1987	Long European-style date
<code>&lt;\$time12L&gt;</code>	4:12 p.m.	12-hour clock time, lowercase
<code>&lt;\$time12U&gt;</code>	4:12 P.M.	12-hour clock time, uppercase
<code>&lt;\$time24&gt;</code>	16:12	24-hour clock time

The `<$lastpage>` code makes it possible to create page numbering in the form "Page 6 of 25." Such a footer would use this form:

**Page `<$page>` of `<$lastpage>`**

Note also that the Page Numbers dialog, which is displayed when you choose the Page Numbers command, includes a field called "This page #." If you don't enter anything in this field, the numbering automatically starts with the first page with the `<$page>` code as page 1, but you can use this field to start page numbering with any number up to 99.

You can use the "This page #" field to reset the page number more than once in a document. For example, you could produce a document whose pages are numbered 1, 2, 3, 7, 8, 9, 1, 2, 3, 4, and so on.

The date and time that appear on the screen and the date and time actually saved in the document will differ in this manner:

- At first, the screen shows the date and time you chose the **Make Header** command. Thereafter, it updates the date and time every time you cause the screen to redraw (for example, by scrolling the work area or displaying a dialog).
- The date and time saved in the document are the date and time you chose the **Save** or **Save as** command.

The following narrative describes how this works:

1. At 10:30 A.M. on April 20, you choose **Make Header**. The header on the screen reads 10:30 A.M., April 20.
2. At 10:40 you're still in the same place. You haven't scrolled the work area, displayed a dialog, or otherwise caused the screen to redraw. The header still reads 10:30.
3. You scroll the header out of the work area. At 10:45 you scroll it back into view. The header now reads 10:45.
4. At 11:00 you save the document and print it. The printed document reads 11:00 A.M., April 20.
5. At 9:45 A.M. on April 22, you open the document again. The header now reads 9:45 A.M., April 22.

Many documents (including this one) use sectional paging, like 3-21 or B-16. Sectional paging in Publisher requires a different header for each section, with the section number or letter before the page code, as in the following examples:

**3-<\$page>**  
**B-<\$page>**

## Alternating Headers

Many documents use different headers on odd- and even-numbered pages. For example, you might want the document title on the left for even pages and on the right for odd pages. Similarly, you might want even page numbers to appear at the left margin and odd page numbers to appear at the right margin. In Publisher, both are possible, as in the illustration below.

<b>User's Guide</b> ..... ..... .....	<b>User's Guide</b> ..... ..... .....
<b>B-14</b>	<b>B-15</b>

### Creating Alternating Headers

The first step in creating alternating headers is to create separate GEM Draw Plus files for each header. For example, to create the headers illustrated above, you need four header files:

- odd-page header (right-aligned document title)
- odd-page footer (right-aligned page number)
- even-page header (left-aligned document title)
- even-page footer (left-aligned page number)



Once you feel really at home with Publisher and GEM Draw Plus, you can do it all in a single file, as described later in this section. When you're getting started, it's easier to use separate files.

The following steps describe how you use Publisher to add alternating headers to your document. We'll call the header files ODDHEAD.GEM and EVENHEAD.GEM.

1. Lay out the first page of the document, including all text and graphics rectangles. This is the time to get or create style sheets and do basic text formatting.
2. Add a rectangle for the header on the first page.
3. Change the file extension indicator in the mini-selector to .GEM and then click on ODDHEAD in the mini-selector window. This loads ODDHEAD.GEM into the header rectangle.
4. With the header rectangle selected, choose the **Make Header** command from the Edit Menu.
5. Press PgDn to display the second page of the document. Note that the header rectangle automatically appears on the second page, although at this point it still contains ODDHEAD.GEM. The remaining steps replace ODDHEAD.GEM with EVENHEAD.GEM on the even numbered pages.
6. Make sure the header rectangle on the second page is selected and that the file extension indicator in the mini-selector is still set to .GEM. (They should be, unless you've digressed from this sequence.)
7. Click on EVENHEAD in the mini-selector window. This puts EVENHEAD.GEM into the header rectangle on the second page.

If you press PgDn to display the third page, ODDHEAD.GEM is in the header rectangle. If you press PgDn again, EVENHEAD.GEM is in the header rectangle of the fourth page. The headers continue to alternate for the rest of the document.

## Putting All Your Headers in One File

Creating your headers in separate files is perhaps the easiest way to work with headers, but it also has a drawback: It can contribute to a potentially confusing proliferation of files.

As an alternative, you can create a single GEM file that contains all your headers for the document. This requires some additional steps in GEM Draw Plus and Publisher, but if you are experienced with both of these programs, you'll find it's worth it.

There are several rules and suggestions to follow when you're creating a single file containing all your headers.

- The background rectangles for all headers in the file must be the same width, even if some are long headers with full-page rules and others are very short page numbers. See the illustration that follows this discussion.
- Each individual header should be a group, made with the GEM Draw Plus **Make Group** command. (See your *GEM Draw Plus* guide.)
- This step is optional, but it makes bringing the headers into rectangles in Publisher much easier. After you have grouped the headers, display the GEM Draw Plus rulers and space the headers at even vertical distances from each other. For example, you could make the top of each header half an inch below the one above it.
- All the headers *must* be centered relative to each other. In other words, one header can't stick out to the left and another to the right. To center them, select all the grouped headers with the **Select All** command from the **Modify** Menu, and then choose the **Align Center** command from the **Alignment** Menu.

The illustration below shows one possible combination of headers in a single file, an odd-page header and number and an even-page header and number.

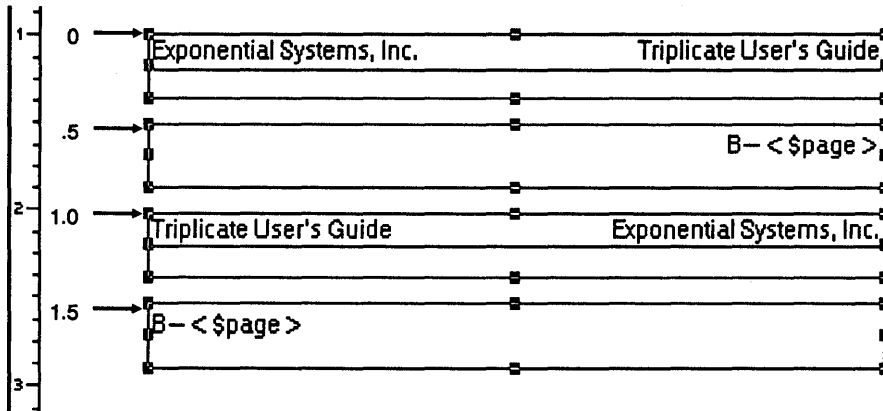

When you bring the headers into rectangles in Publisher, you need to specify their vertical position in the file. The topmost header always has a vertical position of zero inches. In this file, the remaining headers are at .5 inch, one inch, and 1.5 inch. You'll see how to use these numbers in a moment.

## Laying Out the First Page

Here are the steps for laying out the first page of a document, using a single file for your headers:

1. Create and fill all your text and graphics rectangles.
2. Add a header rectangle at the top of the page.
3. Put the header file (we'll call it HEADER.GEM) into the header rectangle. Because graphics rectangles are by default scaled, at first you see all of HEADER.GEM. You'll change that in the next step.
4. With the header rectangle selected, choose the **Make Header** command from the Edit Menu. The headers are now cropped in the rectangle, with the odd-page header at the top. Size the rectangle so that only the top header is visible.
5. Add a rectangle for the page number at the bottom of the page. The rectangle should be the same size as the header rectangle at the top of the page.
6. Put HEADER.GEM into the new rectangle. Again, all of HEADER.GEM appears in the rectangle.
7. With the page number rectangle selected, display the Edit Menu and choose the **Make Header** command.
8. Display the Attributes Menu and choose the **Rectangle** command. Click the pointer on the vertical alignment field at the bottom of the dialog, press the Esc key to clear the field, and enter the vertical coordinate of the page number in HEADER.GEM. In the illustration, the vertical coordinate is .5.  
Exit the dialog. The odd-page number now appears in the rectangle.

## **Laying Out the Second Page**

To lay out the second page:

1. Press PgDn to display the second page. Note that both the header and page number automatically carry over to this page, although they are still set for the righthand page.
2. Make any changes to the text and graphics rectangles.
3. Switch to Select mode and click on the header rectangle at the top of the page.
4. Display the Attributes Menu and choose the Rectangle command.
5. Click the pointer on the vertical alignment value, press the Esc key to clear the field, and enter the vertical coordinate of the even-page header. In our example, it is 1 inch. Exit the dialog. The even-page header now appears in the rectangle at the top of the page.
6. Select the page number rectangle, display the Attributes Menu, and choose the Rectangle command.
7. In the Rectangle dialog, set the vertical alignment for the even-page number, 1.5 inch in the example.

You have now formatted the headers and page numbers for odd and even pages. As you use PgDn to add pages to your document, you'll see that they automatically appear where you want them on the page.

---

# Word Processor Support

**T**his appendix describes two aspects of how GEM Desktop Publisher interacts with your word processor:

- translating formatted text
- keyboard mapping

To get the most out of Publisher's word processor support, you should be familiar with the material on translating formatted text.

The discussion of keyboard mappings is fairly technical. You might want to read the first couple of paragraphs of that section to get a general idea of what it's about and to decide if you want to go any further.

## Translating Text

Publisher accepts ASCII text from any source, plus formatted text from several word processing applications. "Formatted" refers to the presence in the file of special characters whose functions include setting margins, justifying text, and causing characters to appear in boldface, italics, or with an underscore. These characters do not appear in printed output and, depending on how WYSIWYG the word processor is, often do not appear on the screen.

If you're not sure if the file is in ASCII format, go out to the operating system command line and try to display it with the `TYPE` command. If you can type the file successfully, it is probably in ASCII format. If typing the file produces a lot of strange characters on the screen, the file is probably formatted text.

## Text File Extensions

The Preferences dialog lists the file extensions currently in effect for text files. Publisher supplies a default set of extensions for “Native (ASCII)” text and formatted text from the supported word processors. For example, in the default configuration, Publisher assumes a text file with the .TXT extension is an ASCII file; it assumes a file with the .FWP extension is formatted text from GEM 1st Word Plus and a file with the .MSW extension is formatted text from Microsoft Word.

**Note:** See the discussion of wordprocessing file extensions, under the **Set Preferences** command in Section 8, for an important note on GEM 1st Word Plus, GEM Write, and MultiMate file extensions.

## How Publisher Treats Unformatted Text

When you read an unformatted text file into a rectangle, Publisher makes a two-part file translation:

1. It makes a copy of the file, giving the copy the file extension .ASC.
2. It creates a “temporary workfile” version of the .ASC file in your computer’s memory. The workfile has the extension .TMP. All work on the text (formatting paragraph styles, for example) takes place in the temporary file.

When you save the document, Publisher creates a new version of the .ASC file with the style codes and other formatting attributes you added to the temporary file. The .ASC file becomes part of the document. The original unformatted text file is unaffected by the text formatting process.

Meanwhile, the .TMP file is still in memory. It remains there until you choose the **New**, **To Output**, or **Quit** commands.

If you have more than one text file in your document, Publisher creates .ASC and .TMP files for each text file.

**Note:** Do not assign the ASCII file extension (.TXT is the default) or the extension .ASC to formatted text files. Reading a formatted file with either extension into a rectangle can produce unpredictable results that might cause you to lose work and require you to restart Publisher.

## How Publisher Treats Formatted Text

When the text file you're reading into a rectangle has one of the word processor file extensions listed in the Preferences dialog, Publisher assumes it is formatted text from the word processor associated with that file extension.

When it creates a .ASC version of a formatted text file, Publisher translates the source word processor's formatting characters (for text attributes like boldface, italics, and underscoring) to Publisher's own codes <B>, <I>, and <U> (described under "Text Blocks: Embedded Style Codes" in Section 6).

## Filters

Publisher translates your text files with special programs called *filters*. These programs are located in the FILTERS folder inside the GEMSYS folder—its path is \GEMAPPS\GEMSYS\FILTERS. The name of each filter identifies the word processor whose files it translates—for example, WORDPERF.EXE translates WordPerfect files.

In most cases, you don't need to be concerned with the operation of the filters. The one exception is when you want to translate a large number of files. To do so in Publisher could be time-consuming, and you might find it faster to create a batch file to handle the translations. (Batch files are explained in your operating system manual.)



If you plan to use batch files for your filters, you should include the **FILTERS** directory in your search path (also described in your operating system manual), either by typing this command:

```
PATH C:\GEMAPPS\GEMSYS\FILTERS
```

or (better yet) by adding **C:\GEMAPPS\GEMSYS\FILTERS** to the **PATH** command in your **AUTOEXEC.BAT** file. This command makes it possible for you to use the filter program from anywhere in your directory tree.

The batch file is a series of lines naming the filter, the file to be translated, and the name of the new file to be created, as in this example:

```
WORDPERF FILE1.WPR FILE1.ASC  
WORDPERF FILE2.WPR FILE2.ASC  
WORDPERF FILE3.WPR FILE3.ASC  
WORDPERF FILE4.WPR FILE4.ASC  
WORDPERF FILE5.WPR FILE5.ASC  
WORDPERF FILE6.WPR FILE6.ASC  
WORDPERF FILE7.WPR FILE7.ASC  
...
```

## Using the .ASC Version of a File

Once Publisher has created a .ASC version of your text file, *use the .ASC version for all work on the current document*; it contains the document's style codes. If you go back to the original text file when a .ASC version exists in the same folder, Publisher displays an alert informing you that the resulting file translation would overwrite the existing .ASC file. Overwriting the .ASC file results in a new .ASC file without any style codes, and you'd have to start formatting all over again.

## Creating Different Versions of a Document

Once you have formatted and saved a Publisher document, you can use the same .ASC file to create other documents. If you do, remember these facts:

- Any text changes you make in one document will appear in all other documents that use the same .ASC file.
- The paragraph style names from your style sheet are now part of the .ASC file.

If you won't be changing paragraph style names or otherwise changing the text (including adding or deleting blank lines), you can use the **Get Style Sheet** command to load a new style sheet and then use the **Save as** command to save the new version of the document under a name of its own.

If you will be changing style names or altering the text, use the **GEM Desktop** or the command line to make as many copies of the .ASC file as you plan to create new documents, and then use a different .ASC file in Publisher for each version of the document.

## Keyboard Mapping

The term "keyboard mapping" refers to the way Publisher makes it possible for you to use the keyboard to perform many of the actions you can also do with the mouse. For example, you can use the mouse to choose a command or switch modes or you can press a keystroke combination to do either.

These keystroke combinations are all contained in a keyboard mapping file that Publisher invokes when it first starts up. The purpose of this discussion is to describe the keyboard mapping file and to tell you how you can modify the existing one or create one of your own.

The keyboard mapping currently in effect is identified in the Preferences dialog, and the keystrokes themselves are identified in the menus and the Editing Shortcuts and Icon Shortcuts dialogs. The Preferences dialog has room for as many as four keyboard mapping choices.

## Default Keyboard Mapping: STANDARD.KYS

Keyboard mapping files have the extension .KYS and should always be located in the GEMAPPS folder.

Publisher provides a default keyboard mapping file called STANDARD.KYS. The instructions in this appendix make it possible for you to create your own keyboard mapping file to match your word processor.

All .KYS files are pure ASCII text. You can print STANDARD.KYS with the PRINT command or the GEM Output program. The listing on the next page shows the beginning and end of STANDARD.KYS.

A brief explanation of the "mini-selector line #1" entry (and the entries after it) is in order.

You can use keystrokes, in addition to the mouse, to choose any of the first eight items listed in the mini-selector. What these items are depends on Publisher's current mode. In Select and Rectangle modes, they are files with the extension listed in the file extension indicator. In Text mode they are text styles. In Paragraph mode they are paragraph style names.

For example, to select the bold text style (the second style listed in the mini-selector window in Text mode), you use the keystroke combination for "mini-selector line #2." In STANDARD.KYS this keystroke combination is Ctrl-F2.

The first column contains hexadecimal (hex) codes for keystroke combinations. The middle column contains command names and other action descriptions (like "Delete Character Left" and "Rectangle Mode"). The column on the right contains a shorthand description of the keystrokes defined in the first column.

## STANDARD.KYS Listing

	Publisher info	standard keyboard mappings
	-----	
	desk accessory 1	
	desk accessory 2	
	desk accessory 3	
	desk accessory 4	
	desk accessory 5	
	desk accessory 6	
	(File Menu)	
0017	New	Ctrl-W
000F	Open	Ctrl-O
	-----	
0016	Save	Ctrl-V
000D	Save as	Ctrl-M
0001	Abandon	Ctrl-A
	-----	
0015	To App	
	To Output	Ctrl-U
0011	Quit	Ctrl-Q
	(Edit Menu)	
2000	Cut	Alt-D
2E00	Copy	Alt-C
1600	Paste	Alt-U
	-----	
	Empty Rectangle	
	Center Rectangle	
	-----	
1F00	Select All	Alt-S
2300	Make Header	Alt-H
	(Style Menu)	
7D00	Get Style Sheet	Alt-6
7E00	Save Style Sheet	Alt-7
	-----	
7F00	Copy Para Style	Alt-8
8000	Delete Para Style	Alt-9
	.	
	.	
5700	Paragraph Mode	Shift-F4
6600	mini-selector close box	Ctrl-F9
6700	mini-selector path	Ctrl-F10
5E00	mini-selector line #1	Ctrl-F1
5F00	mini-selector line #2	Ctrl-F2
6000	mini-selector line #3	Ctrl-F3
6100	mini-selector line #4	Ctrl-F4
6200	mini-selector line #5	Ctrl-F5
6300	mini-selector line #6	Ctrl-F6
6400	mini-selector line #7	Ctrl-F7
6500	mini-selector line #8	Ctrl-F8
5800	2 PG view	Shift-F5
5900	Full view	Shift-F6
5A00	Normal view	Shift-F7
5B00	2x view	Shift-F8
5C00	Panner	Shift-F9
5D00	Rulers	Shift-F10

Here's how you read some of the entries in the file:

- The keyboard equivalent of the New command is Ctrl-W. The hex code for Ctrl-W is 0017. Note that 0 in the hex code is always a zero, not the letter O. (A complete listing of the hex codes appears at the end of this appendix.)
- The equivalent for the Paste command is Alt-U (hex 1600).
- The equivalent for Paragraph mode switches is Shift-F4 (hex 5700).

When Publisher reads a .KYS file, it only reads the first column, the hex codes. The other two columns are comments that Publisher actually ignores. However, they play a very important role in the file, as you'll see in a moment.

## Creating Your Own .KYS File

The following steps describe how you create a keyboard mapping file we'll call MYKEYS.KYS. Before we start, you need to know a couple of additional things about .KYS files:

- When editing a .KYS file, *do not add or delete any lines in the file*, including the lines with four dashes (----). Publisher equates line numbers in the file with specific commands and functions. For example, a hex code in the 10th line of the file always determines the key mapping for the New command in the File Menu; a code in the 26th line of the file determines the key mapping for the Center Rectangle command in the Style Menu.
- You can't specify key mappings for the items that come before the File Menu. These are the commands that appear in the PUBLISHR Menu, Publisher Info and the desk accessories.

With that in mind, here's how you create MYKEYS.KYS:

1. At the GEM Desktop or command line, make a copy of the file STANDARD.KYS, naming it MYKEYS.KYS.
2. Print MYKEYS.KYS and note all your changes on the printed copy first, rather than trying to make them directly in the file. Write all the new keystrokes into the righthand column and then use the table at the end of this appendix to enter the corresponding hex codes.

For example, to change the key mapping for the New command from Ctrl-W to Ctrl-N, you'd change the righthand column notation and then change the hex code from 0017 to 000E. To change the key mapping for Rectangle mode in the mode switches to Ctrl-PgUp, you'd change the righthand column from Shift-F2 to Ctrl-PgUp and the hex value from 5500 to 8400.

**Note:** The above changes are only for illustration; you can make any change you like, as long as you only use the keystrokes listed in the table and as long as you don't use any keystroke more than once.

3. Once you've completely marked up the printed copy of MYKEYS.KYS, start your word processor and edit the file.

If your word processor can edit and save ASCII text, make sure you edit in that mode. If it only saves formatted text, you can still create an ASCII file, as described in the next step.

If you don't want a key mapping for a particular command or function, you can leave the first column blank, but, as we noted earlier, *do not delete any lines in the file.*

4. If your word processor is in ASCII mode, save the edited version of MYKEYS.KYS.

If your word processor only saves formatted text, *print* MYKEYS.KYS to a disk file called MYKEYS.KYS. This file will be in ASCII format. Your word processor manual should tell you how to print a disk file.

## Choosing Keyboard Mapping Files

The Preferences dialog can display a maximum of four keyboard mapping buttons. If you have more than four .KYS files in the GEMAPPS folder, decide which four names you want to appear in the buttons and rename the others to an extension like .KYX. You can rename the files with the GEM Desktop or from the operating system command line.

The current keyboard mapping button is highlighted in the Preferences dialog. To select another mapping, click on its button. To make that mapping the default for the next time you start Publisher, display the Options Menu and choose the **Save Preferences** command. **Set Preferences** and **Save Preferences** are described in Section 8.

## Keystroke Hexadecimal Codes

Hex Value	Keystroke	Hex Value	Keystroke	Hex Value	Keystroke
0001	Ctrl-A	3000	Alt-B	5C00	Shift-F9
0002	Ctrl-B	2E00	Alt-C	5D00	Shift-F10
0003	Ctrl-C	2000	Alt-D	5E00	Ctrl-F1
0004	Ctrl-D	1200	Alt-E	5F00	Ctrl-F2
0005	Ctrl-E	2100	Alt-F	6000	Ctrl-F3
0006	Ctrl-F	2200	Alt-G	6100	Ctrl-F4
0007	Ctrl-G	2300	Alt-H	6200	Ctrl-F5
0008	Ctrl-H	1700	Alt-I	6300	Ctrl-F6
0009	Ctrl-I	2400	Alt-J	6400	Ctrl-F7
000A	Ctrl-J	2500	Alt-K	6500	Ctrl-F8
000B	Ctrl-K	2600	Alt-L	6600	Ctrl-F9
000C	Ctrl-L	3200	Alt-M	6700	Ctrl-F10
000D	Ctrl-M	3100	Alt-N	6800	Alt-F1
000E	Ctrl-N	1800	Alt-O	6900	Alt-F2
000F	Ctrl-O	1900	Alt-P	6A00	Alt-F3
0010	Ctrl-P	1000	Alt-Q	6B00	Alt-F4
0011	Ctrl-Q	1300	Alt-R	6C00	Alt-F5
0012	Ctrl-R	1F00	Alt-S	6D00	Alt-F6
0013	Ctrl-S	1400	Alt-T	6E00	Alt-F7
0014	Ctrl-T	1600	Alt-U	6F00	Alt-F8
0015	Ctrl-U	2F00	Alt-V	7000	Alt-F9
0016	Ctrl-V	1100	Alt-W	7100	Alt-F10
0017	Ctrl-W	2D00	Alt-X	7300	Ctrl-left-arrow
0018	Ctrl-X	1500	Alt-Y	4D00	right-arrow
0019	Ctrl-Y	2C00	Alt-Z	7400	Ctrl-right-arrow
001A	Ctrl-Z	3B00	F1	5000	down-arrow
001B	Ctrl-[	3C00	F2	4800	up-arrow
001C	Ctrl-\	3D00	F3	5100	PgDn
001D	Ctrl-]	3E00	F4	7600	Ctrl-PgDn
001E	Ctrl-^	3F00	F5	4900	PgUp
001F	Ctrl-`	4000	F6	8400	Ctrl-PgUp
007F	Del	4100	F7	7700	Ctrl-Home
8100	Alt-0	4200	F8	4700	Home
7800	Alt-1	4300	F9	5200	Insert
7900	Alt-2	4400	F10	5300	Delete
7A00	Alt-3	5400	Shift-F1	7200	Ctrl-PrtSc
7B00	Alt-4	5500	Shift-F2	8200	Alt-dash
7B00	Alt-5	5600	Shift-F3	8300	Alt==
7D00	Alt-6	5700	Shift-F4	0F00	Backtab
7E00	Alt-7	5800	Shift-F5	4B00	left-arrow
7F00	Alt-8	5900	Shift-F6	4F00	End
8000	Alt-9	5A00	Shift-F7	7500	Ctrl-End
1E00	Alt-A	5B00	Shift-F8		





---

# More About Rectangles

This appendix discusses *rectangle layers*, gives an example of using the *phantom rectangle*, describes how you can fit your text around the shape of what's in a graphics rectangle, and explains one of the alerts you might encounter in Publisher.

## Rectangle Layers

Publisher treats the rectangles in the work area as if they were arranged in layers. The first rectangle you add is the bottom (first) layer, the next rectangle is the second layer, and so on. The most recently added rectangle is always "on top."

This layering of rectangles is significant on two accounts:

- It determines how text and graphics rectangles interact:
  - If you put an opaque graphics rectangle on top of a text rectangle, the text flows around the graphics rectangle. (See the discussion of opaque graphics in Section 7.)
  - If you put an opaque text rectangle on top of a graphics rectangle, the text completely covers (blocks from view) the portion of the graphics rectangle that is underneath. (See the discussion of opaque text in Section 6.)
- It affects whether you can select a rectangle. If one rectangle completely covers another, you can only select the rectangle on top. To select the rectangle underneath, you must either move the top rectangle or cut it from the work area.

Occasionally you might want to bring a rectangle from one of the lower layers up to the top. (One of the steps in "Fitting Text to Graphics," later in this appendix, does just that.) Here's how you do it:

1. Select the rectangle you want to bring to the top. If it is covered by other rectangles, move them out of the way. In this instance, *don't cut them*. In the next step you'll cut the rectangle you're bringing to the top, and that will delete any other rectangles in the CLIPBRD folder.
2. Cut the rectangle from the work area, using the Cut command from the Edit Menu.
3. Paste the rectangle back into the work area, using the Paste command, also on the Edit Menu.

Pasting a rectangle into the work area makes it the most recently added and brings it to the top.

## Using the Phantom Rectangle

A "phantom" rectangle is one that doesn't contain anything; instead, it is used strictly for formatting the placement of text on the page. The phantom rectangle takes advantage of the fact that Publisher automatically "flows" text around any rectangle nested in a text rectangle.

There are no particular rules about using phantom rectangles; you can use them as you need them. The example on the next two pages illustrates one possible use of a phantom rectangle.

## Phantom Rectangles: an Example

Let's say you are creating a document whose Body Text has a Left Indent value of one inch (Fig. 1 below). You add a graphics rectangle (Fig. 2), and the text now measures its Left Indent value from the right edge of the graphics rectangle.

### Your Own Print Shop

GEM Desktop Publisher takes text from page until you've got it just the way you want it. You can take text from any word processor or text editor like Write, Wordstar, MultiMate, WordPerfect,

In addition to text, you can incorporate graphics from GEM Draw Plus, image files from GEM WordChart. And graphics on your page, GEM Desktop Publisher will format them for you.

And there are no surprises! When you see what it will look like on your computer screen, that's what it will look like on your printer's output tray. Wait until you see it really what you get. Wait until you see it really what you get.

Fig. 1

### Your Own Print Shop



GEM Desktop Publisher takes text from page until you've got it just the way you want it. You can take text from any word processor or text editor like Write, Wordstar, MultiMate, WordPerfect,

In addition to text, you can incorporate graphics from GEM Draw Plus, image files from GEM WordChart. And graphics on your page, GEM Desktop Publisher will format them for you.

And there are no surprises! When you see what it will look like on your computer screen, that's what it will look like on your printer's output tray. Wait until you see it really what you get. Wait until you see it really what you get.

Fig. 2

You decide there is too much white space next to the picture, so you create a new paragraph style with a Left Indent value of .25 inch. You assign this paragraph style to the text next to the graphics rectangle (Fig. 3).

### Your Own Print Shop

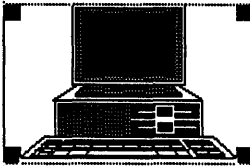

In addition to text, you including picture files from GEM Graph, and wordcharts from GE placement of the graphics on your page, GEM De document for you.

And there are no surprises! When you've what it will look like on your computer's talking about WYSIWYG ("wizywig") the you see is really what you get. Wait till printer's output tray.

Fig. 3

### Your Own Print Shop

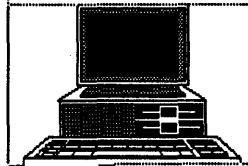

In addition to te including picture graphs from GEM Graph, and the size and placement of the automatically reformats your doc

And there are no surprises! WI what it will look like on your co talking about WYSIWYG ("wizy you see is really what you get. printer's output tray.

phantom rectangle Fig. 4

But now the text that has wrapped under the picture doesn't line up with the rest of the Body Text. To make it line up, add a phantom rectangle that pushes the text back to the one-inch gutter (Fig. 4).

## Fitting Text to Graphics

Section 7 describes the rectangular "extents" around any picture or image you put in a graphics rectangle. Although the extents are always rectangular, the picture itself might not be. In many cases, especially when the picture is placed in the middle of text, the result can be wasted white space on the page. Compare the two document fragments below.

the experienced user, no  
l to be answered before  
posed.

obviously perform best on  
t does not have  
and will perform  
88 and 8086  
a monochrome

r popular GEM  
ately notice a  
EM Publisher.  
when required,  
rg the left side  
o often-used  
unctions and  
ie other GEM  
isher is invoked

cut and paste of a layout  
ibilities on their PC screen.  
provided in a WYSIWYG  
3d to do a lot of trial prints  
on paper.

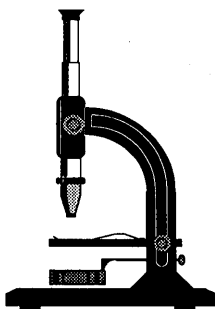

to a wide variety of charac  
fonts that are available on  
font, size, style, weight, a  
whenever needed. These op  
at the rectangle or paragra  
the character le

Blocks of text  
between rectar  
Whenever this  
screen is autor  
how the page  
giving you a tr  
you get" or WY

### Style Sheets

The way par  
including lin  
justification and  
as font, size,  
certain "style" t  
find that certai  
personal taste,  
the project you are working  
are saved in style sheets  
uses in other documents  
graphics need to import  
paragraph styles to specifie

the experienced user, no  
to be answered before  
posed.

obviously perform best on  
it does not have to  
and will perform  
nd 8086 machines,  
r some screen driver

er popular GEM  
ly notice a common  
er. Menus quickly  
3d, and a "control  
provides fast access  
All mouse functions  
e the other GEM  
isher is invoked

t and paste of a  
r capabilities on  
nd pages are provided in a  
re is no need to do a lot of  
it will look on paper.

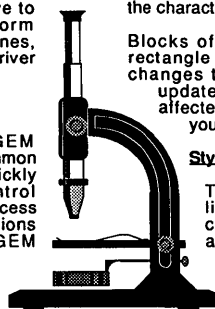

to a wide variety of charact  
fonts that are available on  
font, size, style, weight, ar  
whenever needed. These op  
at the rectangle or paragra  
the character level.

Blocks of text may be ct  
rectangle windows at any  
changes take place, the  
updated to show how t  
affected, giving you a tr  
you get" or WYSIWY

### Style Sheets

The way paragrap  
line spacing, ind  
character attribute  
and color, gives  
document. You  
styles are more  
are more applic  
working on. It  
saved in styl  
succeeding uses in other  
text and graphics need be  
assign paragraph styles to  
they are automatically reform

The fragment on the left was created by simply placing a graphics rectangle in the middle of the text. The fragment on the right required several additional steps, but the end result is more pleasing visually. Here are the steps that produced this "custom fitted" text:

1. Add a rectangle on top of your text and put the graphics file in it. Locate the graphics rectangle where you want it on the text.
2. Lay down a series of small "sub-rectangles" on top of the picture to mark the area to which the text will ultimately conform. The illustration on the next page shows a typical set of these sub-rectangles.

In the illustration, you can see the picture underneath the sub-rectangles, but they are actually opaque and cover the picture.

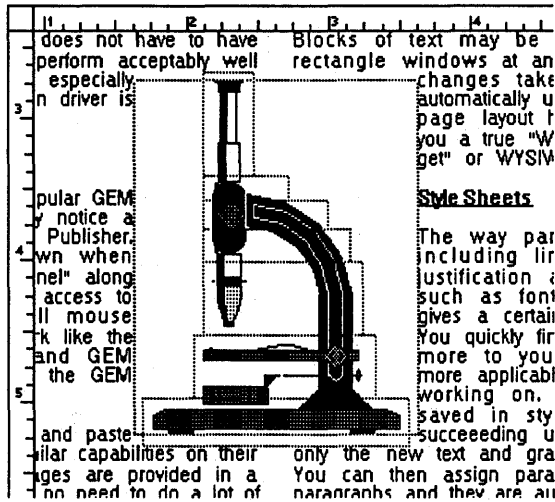

3. When the sub-rectangles are as you want them, switch to Select mode and select the rectangle containing the picture. Using the Cut command (Edit Menu), cut the picture from the work area.
4. Display the Edit Menu and choose the Paste command. This pastes the picture back into the document on top of the sub-rectangles.  
Because the picture rectangle is still in opaque mode (its default), it forces the text to flow fully around its rectangular outline.
5. With only the picture rectangle selected, display the Style Menu, choose the Rectangle command, and set the picture rectangle's mode to "Transparent."

The combination of the transparent picture rectangle and the opaque sub-rectangles causes the text to conform to the shape of the design in the picture rectangle.

## "Word too long" Alert

Occasionally Publisher encounters a situation where it can't fit a word onto a line in a column or text rectangle. In that case, a "Word too long for line" alert is displayed. Starting with the word identified in the alert, no more text appears in the column or rectangle. This situation typically arises as a result of one of these conditions:

- The column or text rectangle is simply too narrow for the word. For example, you might have a tall, skinny rectangle and a very long word.
- You are using a type size that makes the word too big to fit. The word might fit in 28-point type, but not in 36-point type.
- You have placed a rectangle on top of the text in such a way that there isn't enough space beside the rectangle for the word.
- The setting for the first tab position has pushed the text out of the column or rectangle.

The grayed-out text in the picture below identifies the too-long word and the other text that does *not* appear on the screen.





Depending on the cause of the "Word too long" alert, you can solve the problem in a number of ways:

- You can make the rectangle wider.
- You can reduce the number of columns.
- You can use a smaller type size.
- You can move the rectangle on top of the text or change its size.
- You can change the tab settings for the paragraph style of the text that produced the problem.
- You can turn on hyphenation for that paragraph style.

You can turn off the "Word too long" alert by setting the "Show Critical Alerts" button in the Preferences dialog to Off. See the description of the **Set Preferences** command in Section 8.

---

# Managing Your Files

**C**reating a document with GEM Desktop Publisher can involve a considerable number of files: one or more text files, a style sheet, several picture and image files, headers and footers, as well as the document file and output file.

Publisher automatically does a certain amount of file management, but the program can't make all your decisions for you. The purpose of this appendix is to describe the files you might encounter and to offer some suggestions for managing them.

## What Publisher Does for You

As was noted in Section 2, the Publisher installation program creates a folder called GEMPAGES inside the GEMAPPS folder on your hard disk.

Unless you change the Directory line in the Item Selector or the mini-selector, all Publisher file activity by default involves the GEMPAGES folder. This file activity includes the following:

- Publisher looks to GEMPAGES for text and graphics files.
- Publisher assumes all style sheets are in GEMPAGES.
- Publisher saves your documents to GEMPAGES.

Because Publisher defaults to the GEMPAGES folder, you might be tempted to do *everything* in GEMPAGES. Indeed, for a simple document (a page or two, with one or two pictures), this is probably the easiest way to go.

However, for a longer, more complex document, or if you keep several documents in GEMPAGES at the same time, this arrangement could result in a GEMPAGES folder so full of files that you can't keep them straight. There are a number of things you can do to avoid this situation. The first is to know what kinds of files you might run into.

## Files Encountered in Publisher

A file's extension tells you a great deal about what the file is. For example, the extension .GWD identifies a document created by Publisher.

In Publisher, you can encounter files with the following extensions:

.GWD	Publisher document.
.GMP	Output version of a Publisher document.
.GW\$	Backup copy of a Publisher document. This file is created only if you specify in the Preferences dialog that you want it.
.GEM	This extension is assigned to a variety of files. See ".GEM File Extension," later in this appendix.
.IMG	GEM Paint or GEM Scan file you can read into a rectangle.
.STL	Style sheet.
.ST\$	Backup copy of a style sheet.
.ASC	ASCII version of a text file, created by Publisher's file translations. All text files associated with a document have the .ASC extension.
.AS\$	Backup copy of an ASCII text file.
.TXT	Default extension for an unformatted text file.
.FWP	Default extension for a GEM 1st Word Plus formatted text file.
.RFT	Default extension for a DCA-RFT formatted text file.
.MSW	Default extension for a Microsoft Word formatted text file.
.DOC	Default extension for a MultiMate formatted text file.
.WPR	Default extension for a WordPerfect formatted text file.
.WST	Default extension for a WordStar formatted text file.
.GWT	Default extension for a GEM Write formatted text file.

## Item Selector File Extensions

During a Publisher session, the Item Selector appears when you choose commands to open, save, or copy documents or to get or save style sheets. The Item Selector is described fully in Appendix D.

The file extension that appears in the Item Selector's Directory line when you choose the **Open**, **Save as**, **Copy Document**, or **Copy Print Files** command is **.GWD**.

The file extension that appears in the Directory line when you choose the **Get Style Sheet** or **Save Style Sheet** command is **.STL**.

Do not change the extension in the Directory line or type an extension other than **.GWD** or **.STL** in the Selection line. If you do, Publisher returns an "Invalid extension" alert when you exit the dialog and cancels your command.

## Mini-Selector File Extensions

As is noted in Appendix D, the mini-selector's file extension indicator only shows the file extensions **.GEM**, **.IMG**, and the word processor file extensions defined in the Preferences dialog. Note that, with the file extension indicator set to **.GEM**, the mini-selector window can list files *not* created by GEM Draw Plus, as explained next.

## **.GEM File Extension**

The .GEM files listed in the mini-selector window can come from a variety of sources. The following applications create files with the .GEM extension:

GEM Draw Plus GEM Artline	GEM Draw Plus and GEM Artline create a single file with the .GEM extension. You can read this file into a rectangle in Publisher.
GEM Paint GEM Scan	The .GEM file created by GEM Paint and GEM Scan is for use with Output. If you read one of these .GEM files into a rectangle, Publisher automatically gets the corresponding .IMG file.
GEM WordChart	The .GEM file created by GEM WordChart can be read directly into a rectangle in Publisher.
GEM Graph	The .GEM file created by GEM Graph can be read directly into a rectangle in Publisher.

How do you keep track of all these .GEM files?

One solution is *not* to move them into GEMPAGES. Each application creates its own folder for its files, identified in the following list:

<u>application</u>	<u>default folder</u>
GEM Draw Plus	PICTURES
GEM Paint	IMAGES
GEM WordChart	WCHARTS
GEM Graph	GRAPHS

You can leave the .GEM files in the default folders, change the path in the mini-selector (as described in Appendix D), and read the .GEM files in from their default folders. Publisher "remembers" the path information when you do this, so do not move the .GEM files once you have read them into rectangles.

If the default folders already have a lot of files, you can create a folder just for the .GEM files for your current document. You can create the new folder by double-clicking on the GEM Desktop's New Folder icon (see your *GEM/3 Desktop User's Guide*) or by using the operating system's MKDIR command. You can then save all your picture files, image files, wordcharts, or graphs to the new folder by changing the directory path in the Item Selector when you save the file.

## Missing Source Files

If any of a document's text or graphics files or its style sheet file is missing—because you have deleted or moved the file, changed its name, or copied the document without using the **Copy Document** command—Publisher cannot open the document. Instead, Publisher displays an alert naming the file it couldn't find. When you exit the alert, you are presented with an empty work area and a title bar that reads **UNTITLED .GWD**.

The reason Publisher cannot open the document is that a .GWD file contains information that identifies each file in the document and gives its location in the directory path, and Publisher fills text and graphics rectangles by reading the files in from the folders named in the .GWD file. If any of the source files is not where the path information in the .GWD file says it is, Publisher has no way of finding that file.

If the missing file is a text file (.ASC) or graphics file (.GEM or .IMG), you can open the document after you restore the missing file to the path named in the alert.

To do so, quit Publisher and return to the GEM Desktop or the command line. If you deleted the file, you can either recreate it and save it to the same folder as the original file, or you can copy and rename another file of the same type to the path and filename in the document. If you moved the file, put it back where it was when you created the document. If you changed the file's name, change it back to the original name. Then restart Publisher and open the document again.

If the missing file is the document's style sheet, you can copy and rename another style sheet to replace the missing file. The style sheet you copy must contain *as many or more* paragraph style names as the one you are replacing.

One way to be sure the style sheet you're copying has enough style names is to create a special style sheet file just for this eventuality. Using the **Copy Para Style** command, copy the **Body Text** style (giving the new styles names like 1, 2, 3, 4, and so on) until Publisher says you can't make any more. Save the style sheet (a name like PARACHUT.STL comes to mind) and then use it if you ever need a "generic" style sheet.

## File Management Tips and Reminders

Here are tips to help you manage your files in Publisher:

- You can create a separate folder for each document and collect all its associated files in that folder. In addition to organizing your files coherently, this solution has an additional advantage: If you start Publisher by double-clicking on a .GWD icon in a given folder, the directory paths in the Item Selector and mini-selector automatically point to that folder.
- You can create a separate folder for your style sheets.
- When you've finished a document, you can archive it by copying it to a floppy disk with the **Copy Document** command. After verifying that all files are on the floppy disk, you can delete the document and its associated files from your hard disk, thus saving space on the disk.
- You can reduce the number of files by turning Off "Save GMP with doc" until you are ready to print your document. See the description of the **Set Preferences** command in Section 8.

And two reminders:

- The files that go into a document can come from different directories (folders), but they must all be from the same disk. For example, you cannot create a document with some files on a hard disk and others on a floppy disk.
- You can use the same file more than once in a document, if the path is the same each time--for example, C:\PICTURES\ROBOT.GEM. You cannot, however, use the same filename from different paths, like C:\PICTURES\ROBOT.GEM and C:\GEMPAGES\ROBOT.GEM. This would create a problem for the **Copy Document** command, which cannot copy two files with the same name to the same destination. When this situation arises, Publisher displays an alert telling you that, to use both files, you must rename one of them.





---

# Item Selector and Mini-Selector

**T**he Item Selector is a special dialog that is used for:

- opening (recalling) existing documents
- naming and saving documents
- getting style sheets for your documents
- saving the current paragraph styles as a style sheet

The mini-selector, a small version of the Item Selector, is located in the toolkit and is used for:

- putting text into rectangles
- putting .GEM or .IMG files into rectangles
- creating and assigning paragraph styles
- changing text styles

## Item Selector

These commands cause the Item Selector to appear:

- Open
- Save as
- Get Style Sheet
- Save Style Sheet

### Item Selector Components

The illustration below shows the Item Selector and its components.

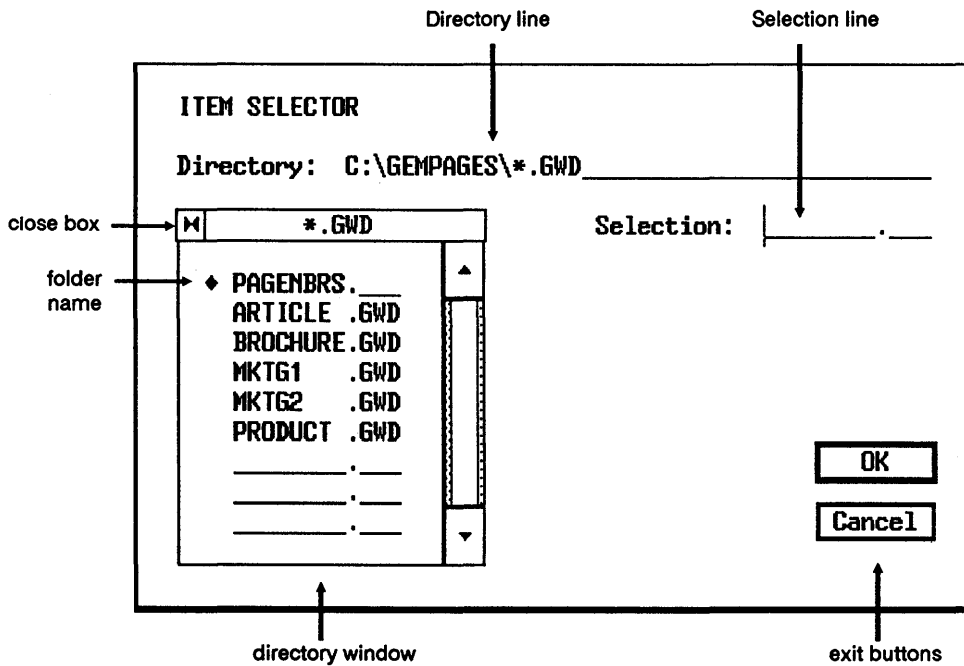

## Directory Line

The Directory line tells where the files listed in the directory window are located. The information in the Directory line is called a "directory path." The table below shows how you read a Directory line.

### Directory Lines

Directory Line	What It Means
<b>A: \GEMPAGES\*.GWD</b>	all documents with type GWD in a folder called GEMPAGES on drive A
<b>C: \GEMPAGES\NEWS\*.STL</b>	all files with type STL in a folder called NEWS, which is itself inside the GEMPAGES folder on drive C

The asterisk (\*) "wildcard" character takes the place of a filename or file extension. For example, \*.GWD means "all files with type GWD."

For more about directory paths, see your *GEM/3 Desktop User's Guide*.

## Directory Window

The directory window lists all folders and files contained in the directory that is named on the Directory line. (Folder names always appear first in the directory window; a diamond precedes their names.) The window can only show nine names at a time. Use the scroll bar, arrows, and slider to move up and down in the directory window if it contains more than nine files.

## Changing the Directory Path

By changing the directory path, you can do either of the following:

- Specify a different directory (folder) in which to store a document or style sheet.
- Specify a different directory (folder) from which to open a document or style sheet.

You can change the directory path with the mouse or by editing the Directory line.

When you change the directory path and exit the Item Selector (clicking on the OK button or pressing the Enter key), Publisher “remembers” the new path. The next time the Item Selector appears in the current session, the new path appears in the Directory line.

**Note:** Changing the path in the Item Selector has no effect on the path in the mini-selector.

### Using the Mouse

To use the mouse to move down the directory path (in other words, to see what’s in a folder currently listed in the directory window), click on the folder’s name.

For example, if the Directory line reads C:\\*.GWD and you click on the folder name GEMPAGES in the directory window, this is what happens:

- The Directory line changes to C:\GEMPAGES\\*.GWD.
- The directory window lists all files with the .GWD type in the GEMPAGES folder, plus any folders inside GEMPAGES.

To use the mouse to move *up* a level in the directory path (back toward the root directory), click on the directory window's close box. For example, if the Directory line reads C:\GEMPAGES\\*.GWD when you click on the close box, this is what happens:

- The Directory line changes to C:\\*.GWD.
- The directory window lists all files with the .GWD type in the root directory, plus any folders in the root.

### Editing the Directory Line

Using the dialog editing keys (left- and right-arrow, Backspace, Del, and Esc), you can change the directory path in the Directory line.

After you change the Directory line, you must update the directory window so that it shows the contents of the folder you named. To update the directory window, either click inside the directory window or press the Enter key.

### **Selection Line**

The Selection line is where you type the name of a document or style sheet you are storing on disk or recalling from disk. In actual practice, you will probably only use the Selection line when naming a document or style sheet for the first time.

## Naming and Saving a Document or Style Sheet

Unless you're saving your document or style sheet to a folder other than GEMPAGES, naming and saving for the first time requires just these three steps:

1. When you are ready to save, choose the **Save as** command from the File Menu or the **Save Style Sheet** command from the Style Menu.
2. When the Item Selector appears, type the name of your document or style sheet in the Selection line. You don't have to type .GWD or .STL; Publisher supplies it automatically.
3. Click on the Item Selector's OK button.

To save to another folder or disk, change the directory path with the mouse or by editing the Directory line before entering the name in the Selection line.

If you're saving a document for the first time, the filename in the window's title bar changes from UNTITLED.GWD to FILENAME.GWD, where FILENAME is the name you provide.

## Opening a Document; Getting a Style Sheet

To open a document, choose the **Open** command, change the directory path (if necessary), and then:

- Double-click on the document's name in the directory window. This is the fastest method.
- Click on the document's name in the directory window. Publisher inserts the name in the Selection line. Click on the OK button or press the Enter key.
- Type the document's name on the Selection line, then click on the OK button or press the Enter key.

The procedure for getting a style sheet is exactly the same as for opening a document, except that you use the **Get Style Sheet** command.

## Mini-Selector

The mini-selector's function depends on Publisher's current mode:

- In Select and Rectangle modes, you use it to read text or graphics files into rectangles.
- In Paragraph mode, you use it to create and assign paragraph styles.
- In Text mode, you use it to change styles for selected blocks of text.

### Mini-Selector Components

The mini-selector is made up of these components:

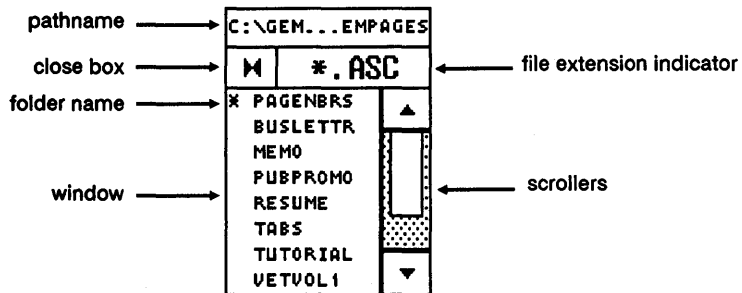

Because they are only used in Select and Rectangle mode, the pathname, close box, and file extension indicator are grayed out in Paragraph and Text mode.



## Reading Files into Rectangles

Before you can read a file into a rectangle, the rectangle must be selected, as indicated by the handles at its corners. To select a rectangle, switch to Select mode and click anywhere inside the rectangle.

To read a text or graphics file into the selected rectangle, simply click on its name in the mini-selector window. Publisher processes the file--translating a word processor file to ASCII format (if need be), fitting a .GEM or .IMG file--and then reads it into the rectangle.

To change what's in a rectangle, select the rectangle and then click on another filename in the mini-selector window. Publisher reads that new file into the rectangle. The files do not all have to be the same type; you can replace a graphics file with a text file, or vice versa.

When you start Publisher, the mini-selector window lists all files in the GEMPAGES folder with the "Unformatted" text file extension defined in the Preferences dialog (.TXT is the default). Thus, to read in a file called HANDBILL.TXT that is in the GEMPAGES folder, just scroll the window (if necessary) until HANDBILL is visible and then click on the name.

To read in a file with a different file extension, change the file extension indicator, as described next. To read in a file from another directory, you must also change the directory path, as described later in this appendix.

## Changing File Extension

To change the file extension indicator so you can read in a file with an extension other than the one currently visible, click on the file extension indicator itself. Publisher cycles through the valid extensions one at a time. If you hold down the mouse button, Publisher cycles continuously. By Shift-clicking, you can cycle through in the reverse direction.

Valid extensions are .GEM, .IMG, .ASC, and the text file extensions defined in the Preferences dialog. By removing extraneous file extensions from the Preferences dialog, you make using the mini-selector faster and easier.

## Changing Path

If the file you want is not in the current folder, you must change the directory path in the mini-selector.

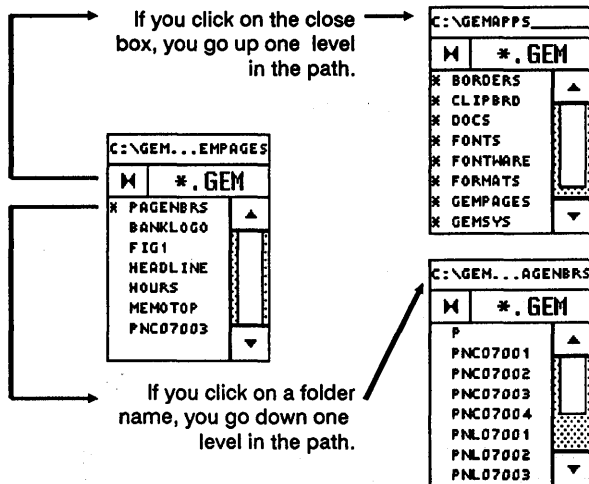

- To go down the directory path and get a file from a folder inside the current folder, click on the folder name in the mini-selector window.
- To go up the directory path and get a file from a folder elsewhere on the same disk, click on the mini-selector's close box until the folder name appears in the window.
- To get a file from another disk, click on the close box until the disk drive identifiers appear in the window. Then click on the drive identifier for the disk that contains the file you want.

Note that all the files in a document must come from the same disk. They can be in different folders, but they cannot be on different disks.

## **Creating and Assigning Paragraph Styles**

When you switch Publisher to Paragraph mode, the mini-selector grays out the path and file extension indicator and lists the current paragraph style names in the window.

Section 5 describes creating and assigning paragraph styles in detail. Here's a brief recap:

- When you use the Copy Para Style command and enter a new paragraph style name, the name appears in the mini-selector window. You can then assign the style to a paragraph and format its attributes, as described in Section 5.
- When you select a paragraph or group of paragraphs and then click on a style name in the mini-selector window, Publisher assigns the attributes of that paragraph style to the selected paragraph(s).

## **Changing Text Style**

When you switch Publisher to Text mode, you can use the mini-selector to change the style of selected blocks of text. Section 6 describes this in detail.

---

# Index

2 PG size, 3-11, 8-8  
2x size, 3-11

## A

**Abandon** command, 8-3  
"Abandon/Save" alert, 8-5  
.ACC file extension (desk accessories),  
8-28  
alerts  
    "Abandon/Save edited document?,"  
    8-5  
    "Duplicate filename," C-7  
    "Invalid extension," C-3  
    "Word too long for line," B-7  
**Align** option (graphics rectangles), 7-8  
**Alignment** (Paragraph dialog), 5-12  
.AS\$ file extension, 8-23, C-2  
.ASC file extension, 8-21, A-2, A-4, C-2  
ASCII text, A-1  
    file translation, A-2  
asterisk (wildcard character), D-3  
at-sign (@), 5-24  
**Attributes** Menu, 8-10  
**Auto Grid Off/On** command, 8-15  
**Auto Reformat** (Preferences dialog), 8-25

## B

<B> code, 6-13, A-3  
backup files, 8-23  
base rectangle, 3-8  
**Best Fit** (graphics rectangles), 7-6  
**Body Text**  
    formatting, 4-9  
**Body Text** paragraph style, 5-3  
bullets, 6-16

## C

caret symbol (in menus), 8-1  
**Center Rectangle** command, 8-6  
centered text, 5-12  
**Character** command, 4-9, 4-15, 5-7, 6-11,  
6-14, 8-10  
characters  
    formatting, 5-7  
click (mouse technique), 1-4  
CLIPBRD folder, 6-15, 8-7  
    rectangles deleted by quitting, 8-7  
close box  
    directory window, D-5  
closing folders in Item Selector, D-5  
**Color** (Character dialog), 5-8  
**Color** (Graphics Rectangle dialog), 7-3  
**Color** (Text Rectangle dialog), 6-19  
**Column Spacing** (text rectangles), 6-20  
**Columns** (text rectangles), 6-20  
    not saved in style sheets, 6-20

## commands

- Abandon, 8-3
- Auto Grid Off/On, 8-15
- Center Rectangle, 8-6
- Character, 4-9, 4-15, 5-7, 6-11, 6-14, 8-10
- choosing, 3-7, 8-1
- Copy, 4-26, 6-15, 8-6
- Copy Document, 8-18, C-3
- Copy Para Style, 4-14, 5-4, 8-9, D-10
- Copy Print Files, 8-20, C-3
- Cut, 6-15, 8-6
- Delete Page, 8-16
- Delete Para Style, 8-9
- Editing Shortcuts, 6-8, 8-27
- Empty Rectangle, 8-6
- Fill Attributes, 7-12, 8-11
- GEM PUBLISHR, 3-1
- Get Style Sheet, 5-22, 8-9, A-5, C-3, D-2, D-6
- Go to Page, 8-16
- Grid Size, 8-17
- Hide Graphics, 8-13
- Hide Toolkit, 8-15
- Hyphenate Word, 5-16, 8-26
- Hyphenation, 5-15, 8-10
- Icon Shortcuts, 3-10, 8-27
- Image Size, 3-13, 8-17
- Insert Page, 8-16
- Item Selector, D-2
- Landscape, 8-15
- Line Attributes, 4-29, 7-12, 8-11
- Make Header, 4-20, 4-22, 8-7, 9-4
- New, 8-2
- Open, 3-1, 8-2, C-3, D-2, D-6
- Page Numbers, 8-12, 9-5
- Paragraph, 4-11, 4-16, 5-9, 8-10
- Paragraph Tabs, 5-18, 8-11
- Paste, 4-26, 6-16, 8-6 - 8-8
- Portrait, 8-15
- Publisher Info, 8-28
- Quit, 8-4
- Rectangle, 7-3, 8-11
- Rulers in Inches, 3-13, 8-15, 8-17
- Save, 4-23, 8-2
- Save as, 4-23, 8-3, C-3, D-2
- Save Preferences, 3-2, 8-26
- Save Style Sheet, 5-22, 8-9, C-3, D-2
- Select All, 8-7
- Select Width Table, 8-27
- Set Preferences, 3-2, 8-21, B-8
- Show Graphics, 8-13
- Show Position, 8-13
- Show Size, 8-14
- Show Toolkit, 8-15
- Status, 8-27
- To App, 8-3
- To Output, 4-30, 8-4
- unavailable, 8-1
- Copy command, 4-26, 6-15, 8-6
- Copy Document command, 8-18, C-3, C-7
- Copy Para Style command, 4-14, 5-4, 8-9, D-10
- Copy Print Files command, 8-20, C-3
- copying, 8-6
  - text blocks, 6-15

cross hair, 3-13  
Ctrl key, 6-10  
current page, 3-11, 8-8  
Cut command, 6-15, 8-6  
cutting, 8-6  
    text blocks, 6-15

## D

date  
    in headers, 9-4, 9-6  
Decimal Tab Character, 5-19  
defaults, 1-5  
Delete Page command, 8-16  
Delete Para Style command, 8-9  
desk accessories, 8-28  
    disabling, 8-28  
diamond symbol  
    in Item Selector, D-4  
    in menus, 8-1  
Directory line (Item Selector), D-3  
    editing, D-5  
directory path, 3-9, C-5, D-3  
    changing in Item Selector, D-4  
    changing in mini-selector, D-9  
directory window (Item Selector), D-3  
    close box, D-5  
    updating, D-5  
.DOC file extension, 8-22, C-2  
documents  
    copying to/from another  
        disk/directory, 8-18  
    copying print files to another  
        disk/directory, 8-20

files and disks, C-7, D-9  
naming, D-6  
opening, 8-2, D-6  
opening, what Publisher remembers,  
    8-5  
printing, 4-30  
saving, D-6  
double-click (mouse technique), 1-4  
drag (mouse technique), 1-4  
"Duplicate filename" alert, C-7

## E

Edit Menu, 8-6  
Editing Shortcuts command, 6-8, 8-27  
Editing Shortcuts dialog, A-6  
editing text, 6-8  
    Ctrl key, 6-10  
editing the Directory line, D-5  
Empty Rectangle command, 8-6  
Enter key  
    to update directory window, D-5  
Esc key, 5-10  
extents, 7-7, B-5

## F

file extensions, C-2  
    .ASC, 8-21  
    in Item Selector, C-3  
    in mini-selector, C-3  
    valid extensions for rectangles, D-8

- file management, C-1
  - .GEM files, C-4
  - tips and reminders, C-7
- File Menu, 8-2
- fill attributes
  - presetting, 7-12
- Fill Attributes command, 7-12, 8-11
- filter extensions
  - text files, 8-21
- filters, A-3
- First Line Indent (Paragraph dialog), 5-10
- folders, 2-2
  - created by GEM applications, C-4
  - creating, C-5
  - in directory window, D-4
  - opening in Item Selector, D-4
- Font (Character dialog), 5-7
- fonts, 5-7
  - changing, for text blocks, 6-14
- footers, 9-1
  - Make Header command, 8-7
- formatted text, A-1
  - file translations, A-3
- full box, 3-14
- Full size, 3-11
- .FWP file extension, 8-22, C-2

## G

- GEM 1st Word Plus
  - file extensions, 8-22
- GEM Desktop Publisher
  - installing, 2-3
  - menus, 8-1
  - starting directly to document, 3-5
  - starting from GEM Desktop, 3-1
  - starting to previous document, 8-23
  - startup directly to document, 3-2
  - startup from command line, 3-1
- GEM Draw Plus, C-4
  - combining headers in one file, 9-9
  - creating headers, 9-1
- .GEM file extension, C-2, C-4
  - GEM Draw Plus, C-4
  - GEM Graph, C-4
  - GEM Paint, C-4
  - GEM WordChart, C-4
  - managing .GEM files, C-4
- GEM Graph, C-4
- .GEM graphics files, 7-1
- GEM Output, 4-30
- GEM Paint, C-4
- GEM PUBLISH command, 3-1
- GEM Setup, 2-2
- GEM system software, 2-2
- GEM WordChart, C-4
- GEM Write
  - file extensions, 8-22
- GEMAPPS folder, 3-1
- GEMBOOT folder, 8-28
- GEMPAGES folder, 3-3
  - Publisher file activity in, C-1

**Get Style Sheet** command, 5-22, 8-9,  
A-5, C-3, D-2, D-6  
.GMP file extension, 3-2 - 3-3, 8-20  
**Go to Page** command, 8-16  
graphics  
    fitting text around, B-5  
    importing, 4-18, 7-1  
**Graphics** (Graphics Rectangle dialog),  
    7-6  
graphics elements, 4-27, 7-10  
    attached to rectangle, 4-29, 7-10  
    drawing, 7-11  
    drawing a line, 4-27  
    pasting, 8-8  
graphics files  
    extents, 7-7  
    missing, C-5  
    reading into rectangles, D-8  
**Graphics mode**, 3-10, 4-27, 7-10  
**Graphics options** (graphics rectangles),  
    7-6  
**Graphics Rectangle** dialog, 7-3  
graphics rectangles  
    Align option, 7-8  
    Best Fit option, 7-6  
    Color, 7-3  
    Graphics options, 7-6  
    Maintain option, 7-6  
    Mode, 7-5  
    Pattern, 7-3  
greeked text, 3-12  
grid size, 8-17  
**Grid Size** command, 8-17  
grid snap, 8-15  
.GW\$ file extension, 8-23, C-2

.GWD file extension, 3-2 - 3-3  
.GWT file extension, 8-22, C-2

## H

header codes, 9-4 - 9-5  
headers, 4-20, 9-1  
    adding to document, 9-3  
    aligning in background rectangle  
        (GEM Draw Plus), 9-3  
    background rectangle, 9-2, 9-9  
    changing from scaled to cropped, 9-4  
    codes for date, time, and page, 9-4  
    combining in single file, 9-9  
    creating, 9-2, 9-7  
    graphics rectangles, 9-1  
    groups (GEM Draw Plus), 9-3, 9-9  
    in background rectangle  
        (GEM Draw Plus), 9-9  
    **Make Header** command, 8-7  
    reading into rectangle, 9-3  
    sectional paging, 9-6  
    spacing in GEM Draw Plus, 9-9  
hexadecimal codes  
    in .KYS files, A-6  
**Hide Graphics** command, 8-13  
**Hide Toolkit** command, 8-15  
**Hyphenate Word** command, 5-16, 8-26  
hyphenation, 5-15, 6-11  
**Hyphenation** command, 5-15, 8-10



**I**

- <I> code, 6-13, A-3
- I-beam, 3-13, 6-4
- Icon Shortcuts command, 3-10, 8-27
- Icon Shortcuts dialog, A-6
- Ignore Space Above (Paragraph dialog), 5-13
- image files, 4-25
  - not output to screen, 8-4
- image size, 8-17
- Image Size command, 3-13, 8-17
- .IMG file extension, C-2
- .IMG graphics files, 7-1
- importing graphics, 7-1
- Info/Rename command (GEM Desktop), 8-28
- Insert Page command, 8-16
- INSTALL.APP, 2-3
- installing GEM Desktop Publisher, 2-3
  - multiple hard disks, 2-3
- "Invalid extension" alert, C-3
- Item Selector, 4-23, 8-2, D-1
  - changing directory path, D-4
  - commands, D-2
  - components, D-2
  - illustration, D-2

**J**

- justified text, 5-12

**K**

- kerning, 6-10
- keyboard command equivalents, 8-1
- keyboard mapping, 8-22, A-5
- keyboard mapping files, A-5
  - creating, A-8
  - default, A-10
  - how to read, A-8
  - listing of STANDARD.KYS, A-7
  - order of entries, A-8

**L**

- Landscape command, 8-15
- Landscape format, 8-15
- leading
  - See "Line Space (Paragraph dialog)"
- Left Indent (Paragraph dialog), 5-10
- left-aligned text, 5-12
- line attributes
  - end styles, 7-12
  - line width, 7-12
  - no outline, 7-12
  - presetting, 7-13
  - styles, 7-12
- Line Attributes command, 4-29, 7-12, 8-11
- Line Space (Paragraph dialog), 5-11

**M**

Maintain (graphics rectangles), 7-6  
Make Header command, 4-20, 4-22, 8-7,  
9-4  
memory  
    making more available, 8-28  
menus, 8-1  
    choosing commands, 3-7  
    displaying, 3-7, 8-1  
    removing from screen, 3-7  
mini-selector, 3-11, D-1, D-7  
    changing directory path, D-9  
    changing file extension, D-8  
    changing text style, 6-12  
    components, D-7  
    in Paragraph mode, D-10  
    in Select or Paragraph mode, D-8  
    reading in header files, 9-3  
    valid file extensions, C-3, D-8  
Mode (Graphics Rectangle dialog), 7-5  
Mode (Text Rectangle dialog), 6-19  
mode switches, 3-10  
modes, 3-10  
mouse  
    basic techniques, 1-4  
mouse form, 3-13  
.MSW file extension, C-2  
MultiMate file extensions, 8-22

**N**

<N> code, 6-13  
naming documents, D-6  
New command, 8-2  
Norm size, 3-11  
numbered lists, 6-16

**O**

Opaque mode, 6-19, 7-5  
Open command, 3-1, 8-2, C-3, D-2, D-6  
opening documents  
    what Publisher remembers, 8-5  
opening folders in Item Selector, D-4  
output, 3-3, 8-4  
    displaying multi-page documents,  
    8-4  
    image files not displayed on screen,  
    8-4  
    printing selected pages, 8-25  
output files, 8-23

**P**

page  
    contrasted with work area, 3-8  
Page Menu, 3-8, 3-13  
page number files  
    name codes, 9-2

- page numbers
  - adding, 4-21
  - first number, 9-5
  - in headers, 9-4
  - setting starting number, 8-12
- Page Numbers** command, 8-12, 9-5
- page orientation, 8-15
- page size panel, 3-11
- PAGEBNRS folder, 9-2
- pages
  - current, 3-11
  - deleting, 8-16
  - going to, 8-16
  - inserting, 8-16
  - size of, 8-17
- pages adding, 4-24
- panner, 3-12
  - disables other program functions, 3-12
  - panning rectangle, 3-12
- Paragraph** command, 4-11, 4-16, 5-9, 8-10
- paragraph formatting
  - pica notation, 5-9
  - units of measure, 5-9
  - zero values, 5-10
- Paragraph mode, 3-10
- paragraph spacing, 5-11
- paragraph style codes
  - embedding in text files, 5-24
- paragraph styles, 5-3
  - assigning, D-10, 5-6
  - assigning to selected paragraph, 4-15, 5-5
  - Body Text, 5-3
  - codes, 5-23
  - copying, 5-26
  - creating, 4-14, 5-4, 8-9, D-10
  - deleting, 8-9
  - embedding in text files, 5-24
  - names, 5-4
  - setting attributes, 5-5
  - taking attributes of Body Text, 5-25
  - tips on creating, 5-25
  - using the mini-selector, D-10
- paragraph tabs
  - aligning, 5-19
  - entering decimal value, 5-19
  - formatting, 5-18
  - inserting with Publisher, 5-22
  - measuring, 5-19
  - setting, 5-19
  - setting paragraph tabs, 8-11
  - setting single tab stop, 5-19
  - spaces converted to tabs, 5-22
  - using, 5-20
- Paragraph Tabs** command, 5-18, 8-11
- paragraphs
  - Alignment, 5-12
  - defined, 5-2
  - First Line Indent, 5-10
  - formatting, 5-9
  - Left Indent, 5-10
  - Line Space, 5-11
  - Right Indent, 5-10
  - Space Above, 5-11
  - Space Below, 5-11
  - Tracking, 5-11

**Paste command**, 4-26, 6-16, 8-6 - 8-8  
**pasting**, 8-6

- graphics elements, 8-8
- rectangles, 8-8
- text blocks, 6-16

**path**

- See "directory path"

**path information in command line**, 3-4  
**Pattern (Graphics Rectangle dialog)**, 7-3  
**Pattern (Text Rectangle dialog)**, 6-19  
**PgDn key**, 4-24  
**PgUp key**, 4-24  
**phantom rectangle**

- adding, B-3
- defined, B-2
- to reformat text, B-3

**picture files**, 4-25  
**point size**, 5-8  
**pointer**, 3-13  
**Portrait command**, 8-15  
**Portrait format**, 8-15  
**PostScript**

- point sizes for text, 5-8

**preferences**

- restoring defaults, 8-26
- saving, 8-26
- setting, 8-21
- what is saved, 8-26

**Preferences dialog**, 8-21, A-6, A-10

- file extensions, D-8
- Filter Extensions, 8-21

**previous document (Preferences dialog)**, 3-2, 8-23

**printing documents**, 4-30

- selected pages, 8-25

**Publisher Info command**, 8-28  
**PUBLISHR.APP**, 3-1  
**PUBLISHR.INF**, 8-26

## Q

**Quit command**, 8-4

## R

**Rectangle command**, 7-3, 8-11  
**Rectangle mode**, 3-10  
**rectangles**

- base, 3-8
- bringing to the top, B-2
- changing contents of, D-8
- CLIPBRD folder, 8-7
- coordinates, 8-13
- copying, 8-6
- cutting, 8-6
- deleted from CLIPBRD, 8-7
- layers, B-1
- moving/copying from page to page, 8-8
- pasting, 8-8
- phantom, B-2
- selecting, D-8

- selecting all, 8-7
- selecting rectangle not on top, B-1
- showing size while drawing, 8-14
- text over graphics, B-1
- .RFT file extension, C-2
- Right Indent (Paragraph dialog), 5-10
- right-aligned text, 5-12
- rule, 9-1
- ruler switch, 3-13
- rulers, 3-13, 5-9
  - changing unit of measure, 8-15
  - creating header rectangles, 9-3
  - inches/metric, 8-17
  - unit of measure, 3-13
- Rulers in Inches command, 3-13, 8-15, 8-17
- running heads, 9-1
  - See also "headers"

## S

- Save as command, 4-23, 8-3, C-3, D-2
- Save command, 4-23, 8-2
- Save GMP with doc (Preferences dialog), 8-23
- Save Preferences command, 3-2
- Save Preferences command, 8-26
- Save Style Sheet command, 5-22, 8-9, C-3, D-2
- saving documents, D-6
- SCRAP.ASC, 8-7
- Screen Preferences (Output), 8-4
- scroll arrows, 3-14
- scroll bars, 3-14

- scrolling points, 3-14
- sectional paging, 9-6
- Select All command, 8-7
- Select mode, 3-10, 8-8
- Select Width Table command, 8-27
- Selection line (Item Selector), D-5
- Set Preferences command, 3-2, 8-21, B-8
- Shift-click (mouse technique), 1-4
- Show Critical Alerts (Preferences dialog), 8-24
- Show Graphics command, 8-13
- Show Position command, 8-13
- Show Size command, 8-14
- Show Toolkit command, 8-15
- Size (Character dialog), 5-8
- size box, 3-14
- sliders, 3-14
- SNAPSHOT.ACC, 8-28
- source files
  - missing, C-5
- Space Above (Paragraph dialog), 5-11
- Space Below (Paragraph dialog), 5-11
- STANDARD.KYS, A-6
  - listing, A-7
- starting GEM Desktop Publisher, 3-1 - 3-2
  - what Publisher remembers, 3-5
- Status command, 8-27
- .ST\$ file extension, 8-23, C-2
- .STL file extension, C-2 - C-3
- Style (Character dialog), 5-8
- style codes, 5-23
- Style Menu, 8-9
- Style name (field in formatting dialogs), 5-7

style sheets, 4-8, 5-1, 8-9  
attributes saved, 5-1  
creating, 5-3  
embedding styles in text files, 5-24  
getting, D-6  
missing, C-6  
paragraph style names, 5-4  
saving, 4-23, 5-22, D-6  
style codes, 5-23  
subdirectories  
See "folders"

## T

tables  
creating with paragraph tabs, 5-20  
tabs  
entering in text, 6-12  
spaces converted to tabs, 6-12  
See also "paragraph tabs"  
text  
assigning color, 5-8  
assigning fonts, 5-7  
assigning size, 5-8  
assigning styles, 5-8  
copying, 8-6  
creating new files, 6-6  
cutting, 8-6  
editing, 6-8  
entering in existing files, 4-13, 6-7  
entering special characters, 6-7  
entering tabs, 6-12  
fitting to graphics, B-5

flow around rectangle, 6-20, 7-5, B-2  
flow turned off by Transparent mode,  
6-20, 7-5  
formatting characters, 8-10  
formatting paragraphs, 8-10  
greeked, 3-12  
in Norm size, 3-11  
marking where to paste, 6-4  
pouring into rectangle, 4-6, 6-1  
spaces converted to tabs, 6-12  
underlining (paragraph styles), 5-8  
text blocks  
changing color, 6-14  
changing fonts, 6-14  
changing size, 6-14  
changing style, 6-14  
CLIPBRD folder, 8-7  
copying, 6-15  
cutting, 6-15  
marking, 6-5  
pasting, 6-16  
text color, 5-8  
changing, for text blocks, 6-14  
text cursor, 3-13, 6-4  
text files  
.ASC versions, A-4  
ASCII, A-1  
creating, 4-4  
formatted, A-1  
missing, C-5  
reading into rectangles, D-8  
sample with style codes, 5-23  
text grid, 5-13  
bypassing, 5-14  
Text mode, 3-10, 6-3  
changes to Publisher screen, 6-3

## text rectangles

- Color, 6-19
- Column Spacing, 6-20
- Columns, 6-20
- Mode, 6-19
- Pattern, 6-19
- Vertical Rules, 6-20

## text size, 5-8

- changing, for text blocks, 6-14

## text style, 5-8

- changing, for text blocks, 6-12, 6-14
- embedded codes, 6-13, A-3
- setting in formatted text, A-3

## text style codes, 6-13

- embedding in text files, 6-14
- using as literal string, 6-14

## time

- in headers, 9-4, 9-6

## title bar, 3-9

## .TMP file extension, A-2

## To App command, 8-3

## To Output command, 4-30, 8-4

## toggle, 3-13

## toolkit, 3-10

- hiding, 8-15
- in Graphics mode, 4-28
- keystroke shortcut, 8-27
- showing, 8-15

## Tracking (Paragraph dialog), 5-11

## Transparent mode, 6-19, 7-5, B-6

## TUTORDOC.GMP, 4-1

## TUTORDOC.GWD, 4-1

## TUTORIAL.ASC, 4-1

## TUTORIAL.TXT, 4-6

## TUTSTYLE.STL, 4-1

## .TXT file extension, C-2

## U

## &lt;U&gt; code, 6-13, A-3

## unavailable commands, 8-1

## Underline (Character dialog), 5-8

## underlining (paragraph styles), 5-8

## Unformatted (ASCII) file extension, A-2

## up-arrow symbol (in menus), 8-1

## updating directory window (Item Selector), D-5

## V

## Vertical Rules (text rectangles), 6-20

## W

## wildcard character, D-3

## window, 3-7

- full box, 3-14
- moving, 3-9
- scrolling, 3-14
- sizing, 3-14

## "Word too long" alert, B-7

## work area, 3-8

- contrasted with page, 3-8

## .WPR file extension, C-2

## .WST file extension, C-2





