

NIXDORF

COMPUTER

480

**Improving productivity in a
variety of data entry
environments.**



**80 Series
Data Entry Systems**

NIXDORF
COMPUTER



Judi Knight
Account Manager

Nixdorf Computer Corporation
1815 Century Blvd. • Atlanta, GA 30345
(404) 325-8300

80 SERIES

Operations Manual

NIXDORF
COMPUTER

80 SERIES

Operations Manual

NOVEMBER 1980

Published, July 1977
1st Revision, November 1980

The material in this document is for informational purposes and is subject to change without notice. Although all of the information has been carefully reviewed and is believed to be accurate, Nixdorf Computer Corporation assumes no responsibility for any errors which may appear in this publication.

Copyright © 1979 by Nixdorf Computer Corporation, Burlington, MA 01803. Printed in the United States of America. All rights reserved. Reproduction or use of editorial or pictorial content in any manner without express permission is prohibited.

PREFACE

This manual describes Nixdorf System 280, 380 and 480 operation, and provides the information necessary to achieve a thorough understanding of supervisor activities at the DATA/TERMINAL Keystation(s). All system functions are discussed with reference to System 480. For a complete definition of System 280, 380 and 480 features, please refer to Appendix A.

This manual is comprised of eight Sections, four Appendices, and an Index:

- *Section 1 – Provides a general description of the 80 Series system components, such as, the DATA/TERMINAL Keystation, Central Control Group, and peripheral devices. A summary of Supervisor Functions is also provided at the end of Section 1.*
- *Section 2 – Discusses system Batch Operations which are supervisory functions used to control a batch or batches residing on disk.*
- *Section 3 – Covers Batch Input/Output Operations which are supervisory functions used to process data read into the system or written during an output operation.*
- *Section 4 – Discusses system Utility Operations which includes manual tape handling options and device utility options that are available to be used by the Supervisor.*
- *Section 5 – Covers system Libraries and the Library maintenance functions that allow the Supervisor to enter, store, and manipulate the various formats associated with data entry/output and system management.*
- *Section 6 – Discusses System Operations which provide both hardware and software control of the system as well as aiding in the management and flow of data.*
- *Section 7 – Provides detailed information pertaining to the 80 Series Central Control Group components including the processor, magnetic disk unit(s), and magnetic tape unit(s).*
- *Section 8 – Contains a detailed discussion of the 80 Series system peripheral devices which include a card reader and system printers.*

The four appendices contain reference information including a Summary of Product Line Features in Appendix A, Tape Output Codes in Appendix B, ABL Log Codes and Definitions in Appendix C, and Central Processor Control Panel differences in Appendix D.

REFERENCE MATERIALS

The "80" Series Operations Manual" is one volume of a set of publications describing the Nixdorf System 280/380/480. Other publications in this series include:

- *System Concepts Manual (Order Number 2020)* – Serves as an introductory document and provides an overall description of system operation and use.
- *Operator's Quick-Reference Guide (Order Number 2027)* – Provides "How-To Information" concerning operator activities at the Keystation.
- *Supervisor's Quick-Reference Guide (Order Number 2028)* – Provides summary information pertaining to supervisor functions.
- *Formatting Techniques Manual (Order Number 2029)* – A detailed description of the creation and use of Display Layouts, Input Formats, Standard Job Definitions, and Editor language programming.
- *Site Planning and Preparation Manual (Order Number 2100)* – Provides information and guidance in site planning and preparation for 80 Series system installation.

These manuals, as well as 80 Series coding forms, may be obtained by contacting your local Nixdorf office.

TABLE OF CONTENTS

SECTION 1 SYSTEM OVERVIEW

Paragraph	Page
GENERAL INFORMATION.....	1-1
DATA/TERMINAL KEYSTATIONS.....	1-1
Data Display.....	1-3
Cursor.....	1-4
Data Presentation.....	1-5
Audible Signals.....	1-5
Keyboard.....	1-5
CENTRAL PROCESSOR.....	1-8
CENTRAL DISK.....	1-9
MAGNETIC TAPE UNITS.....	1-9
SUPERVISOR FUNCTIONS.....	1-9

SECTION 2 BATCH OPERATIONS

GENERAL INFORMATION.....	2-1
Asterisk Processor.....	2-1
AT Processor.....	2-1
Valid/Invalid Matching Names Display.....	2-1
Program (PGM) HELP.....	2-2
DISPLAY BATCH STATUS.....	2-2
DISPLAY BATCH LOG.....	2-4
BATCH EDITS.....	2-4
DELETE A BATCH.....	2-5
RENAME A BATCH.....	2-5
SORTS.....	2-6
VALUE TABLES.....	2-7
Standard Value Tables.....	2-8
Indexed Value Tables.....	2-9
Indexed Value Table Batch Format.....	2-10

TABLE OF CONTENTS (CONT.)

SECTION 2 BATCH OPERATIONS (CONT)

Paragraph	Page
VALUE TABLES (cont)	
Indexed Value Table Operation.	2-10
Value Table Operation Procedures	2-11
BATCH PROTECTION.	2-13

SECTION 3 BATCH INPUT/OUTPUT OPERATIONS

STANDARD JOB OUTPUT	3-1
WRITE A BATCH.	3-1
WRITE BATCH STATUS	3-3
WRITE BATCH LOG	3-4
READ STANDARD JOB	3-5
READ BATCH	3-6
SELECTIVE TAPE INPUT.	3-6
APPEND TO BATCH	3-9
READ WITH STD JOB HEADER.	3-9

SECTION 4 UTILITY OPERATIONS

MAGNETIC TAPE CONVENTIONS.	4-2
TAPE HANDLING OPTIONS.	4-3
Write Tape Mark	4-3
Write Tape Mark and Rewind	4-3
Rewind Tape.	4-4
Backspace One Tape Record	4-4
Search For Tape Mark.	4-4
Search For Sequence	4-5

TABLE OF CONTENTS (CONT.)

SECTION 4 UTILITY OPERATIONS (CONT)

Paragraph	Page
DEVICE UTILITIES OPTIONS	4-5
Device From Tape	4-6
Device From Card Reader	4-12
COMMUNICATIONS OVERVIEW	4-13
Communications (Nixdorf to Nixdorf)	4-13
Remote Entry (Nixdorf to Non-Nixdorf)	4-14
Parameterized Communications	4-14
Communications Vocabulary	4-15
Communications Utilities	4-17
COMMUNICATIONS OPERATIONS	4-18
COMMUNICATIONS FEATURES	4-25
Nixdorf to Nixdorf Communications	4-25
2780 Emulation Communications	4-25
PARAMETERIZED COMMUNICATIONS	4-27
Specifying a Parameterized Communications Configuration	4-28
Data Formatting (RCD, BUFF, #RCDS/BUFF)	4-31
Data Discipline	4-33
Intermediate Record Separators	4-35
Bids and Retires	4-35
Identification	4-36
COMMUNICATIONS DYNAMIC TRACE – BISYNC ANALYZER	4-37
Trace Operation	4-37
Sequential Display	4-38
Accumulative Display	4-39
ERROR RECOVERY PROCEDURES	4-39
Handshaking	4-39
Transmitting	4-40
Receiving	4-40

SECTION 5 SYSTEM LIBRARIES

STANDARD JOB LIBRARY	5-2
INPUT FORMAT LIBRARY	5-4

TABLE OF CONTENTS (CONT.)

SECTION 5 SYSTEM LIBRARIES (CONT)

Paragraph	Page
RECORD END EDIT LIBRARY	5-5
BATCH END EDIT LIBRARY	5-7
OUTPUT PROGRAM LIBRARY	5-7
SORT PROGRAM LIBRARY	5-9
EDITOR CODING FORM	5-9
INDIVIDUAL EDITOR LIBRARY INPUT	5-9
COMMAND SEQUENCE PROCESSOR	5-11
Command Sequence Library	5-12
Command Sequence Coding	5-12
Command Sequence Execution	5-15
Command Sequence Library Maintenance	5-16
CODE SET CONVERSION LIBRARY	5-16
OPERATOR STATISTICS	5-18
CHECK DIGIT LIBRARY	5-26
Check Digit Format	5-29
Check Digit Calculations	5-32
Check Digit Flow Chart Explanation	5-36
Alpha Character Check Digit Calculation	5-36
READ ALL LIBRARIES	5-37
WRITE LIBRARIES	5-38

SECTION 6 SYSTEM OPERATIONS

ENTER DATE	6-1
DISK STATUS	6-1
Disk-Cartridge Systems (2.4 - 9.6 Mbytes)	6-2
Disk-Pack Systems (33 Mbytes)	6-2

TABLE OF CONTENTS (CONT.)

SECTION 6 SYSTEM OPERATIONS (CONT)

Paragraph	Page
SYSTEM SAVE.	6-2
Generating a Multi-Reel System Save	6-4
Loading a Multi-Reel System Save.	6-4
ASSIGN TAPE UNIT	6-5
SYSTEM TAPE CODE	6-6
Four-By-Three Tape Packing.	6-6
CHANGE PASSWORD	6-7
NUMERIC ONLY EXCEPTIONS	6-7
COMMUNICATIONS PARAMETERS	6-8
DIAGNOSTIC MODE	6-8
ECHO	6-8
Communications Dynamic Trace (BISYNC ANALYZER)	6-10
33 MEGABYTE DISK UNIT (System 480).	6-10
Loading A Disk Pack.	6-12
Replace Disk Pack	6-13
Disk Pack Transfer	6-14
Disk Pack Handling	6-14
TYPEWRITER OVERSIGN	6-14
OPTIMIZE SYSTEM.	6-15
AUTOMATIC BATCH LOAD (ABL)	6-19
General Operating Parameters	6-19
ABL Procedure	6-20
FORMAT DISK.	6-25

SECTION 7 CENTRAL CONTROL GROUP

SYSTEM CENTRAL PROCESSOR.	7-2
Control Switches.	7-3

TABLE OF CONTENTS (CONT.)

SECTION 7 CENTRAL CONTROL GROUP (CONT)

Paragraph	Page
Maintenance Indicators	7-3
Console Controls	7-4
CENTRAL DISK	7-5
MAGNETIC TAPE UNITS	7-6
Tape Drive Operation	7-6
CONTROL GROUP SPECIFICATIONS	7-8
OPERATIONAL REQUIREMENTS	7-8
Temperature	7-8
Humidity	7-8
Altitude	7-8
Dust and Dirt	7-9
Access	7-9
SYSTEM MAINTENANCE	7-9
Central Control Group Cabinet	7-9
Tape Units	7-9
DATA/TERMINAL Keystation	7-9
Peripheral Devices	7-9
System Tapes	7-10
Tape Cold Starts	7-10
Warm Starts	7-11

SECTION 8 PERIPHERAL DEVICES

MODEL 510 SERIAL PRINTER	8-3
Printing Method	8-3
Paper Control	8-4
Printer Controls	8-4
Manual Controls	8-6
Ribbon Changing	8-7
Forms	8-9
Printer Characteristics	8-10
MODEL 533 LINE PRINTER	8-10

TABLE OF CONTENTS (CONT.)

SECTION 8 PERIPHERAL DEVICES (CONT)

Paragraph	Page
MODEL 536 LINE PRINTER.....	8-11
MODEL 539 LINE PRINTER.....	8-11
Printing Method	8-12
Printer Controls.....	8-12
On-Line Start-Up Procedure	8-17
Shutdown Procedure.....	8-17
Paper Loading	8-17
Ribbon Removal and Installation	8-19
Paper Mask Installation.....	8-22
Vertical Format Unit.....	8-22
Printer Characteristics	8-25

APPENDICES

APPENDIX A – PRODUCT LINE FEATURES	A-1
APPENDIX B – TAPE OUTPUT CODES.....	B-1
APPENDIX C – ABL LOG CODES AND DEFINITIONS.....	C-1
APPENDIX D – CENTRAL PROCESSOR CONTROLS.....	D-1
INDEX	I-1

LIST OF ILLUSTRATIONS

Figure		Page
1-1	Nixdorf System	1-0
1-2	System Data Flow	1-2
1-3	DATA/TERMINAL Keystation	1-3
1-4	Typical Display Presentation	1-4
1-5	DATA/TERMINAL Typewriter Keyboard	1-7
1-6	DATA/TERMINAL Keypunch Keyboard	1-7
2-1	Sort Program "INVSORT"	2-6
2-2	Example of Value Table Batch Entered by Supervisor	2-8
3-1	Batch Status Tape Layout	3-4
3-2	Selective Tape Input Operation	3-7
4-1	Magnetic Tape Conventions	4-2
4-2	Physical Records on Magnetic Tape	4-2
4-3	Data Records Grouped Three to the Block	4-3
4-4	Search for Tape Mark Feature	4-4
4-5	Nixdorf To Nixdorf Communications	4-13
4-6	Nixdorf To Non-Nixdorf System Communications	4-14
4-7	System Operations HELP List (with G selected)	4-28
4-8	Communications Parameters	4-28
4-9	Example of Communications Parameters for Configuration Emulating a 2780	4-30
4-10	Example of Communications Parameters for Configuration Emulating a 3780	4-30

LIST OF ILLUSTRATIONS (CONT.)

Figure	Page
4-11 Example of Communications Parameters for Configuration Emulating a 3741 on a Switched Line	4-31
4-12 Example of Communications Data Formats	4-32
4-13 Example of Space Compression.	4-34
4-14 Example of Data Records Separated by IRS Characters and IUS Characters.	4-35
5-1 Standard Job Definition Form for Sample Program Package INVOICE	5-3
5-2 Input Format Coding Form.	5-6
5-3 Editor Coding Form	5-10
5-4 Command Sequence Layout Form	5-13
5-5 Summary Statistics Format.	5-22
5-6 Batch Statistics Format.	5-22
5-7 Typical Operator Statistics Output Program	5-23
5-8 Summary and Batch Statistics Printout.	5-26
5-9 Check Digit Library Options List	5-27
5-10 Check Digit Format.	5-28
5-11 Weight Assignment	5-32
5-12 Standard Modulus 7 Check Digit.	5-32
5-13 Standard MOD 10 Check Digit	5-33
5-14 Standard MOD 11 Check Digit	5-34
5-15 Check Digit Calculation Flow Chart	5-35
6-1 Unpacked Data on 7-Track and 9-Track Tape	6-6
6-2 Packed Data on 9-Track Tape	6-7
6-3 Central Processor Panel with ECHO ON and Terminal 6 Designated as the "Master"	6-9

LIST OF ILLUSTRATIONS (CONT.)

Figure	Page
6-4 Operator Control Panel	6-10
6-5 Power Panel	6-11
6-6 Optimize System - 8 Terminal Environment	6-17
6-7 Optimize System - 30 Terminal Environment	6-18
6-8 ABL Log Format	6-20
7-1 Nixdorf 80 Series System Central Control Group	7-0
7-2 Data Flow Through the 80 Series System	7-1
7-3 Central Processor Control Panel	7-2
7-4 Nixdorf Standard Tape Drive	7-6
8-1 Model 510 Serial Printer	8-2
8-2 Model 533/536 Line Printer	8-2
8-3 Model 539 Line Printer	8-2
8-4 Model 510 Serial Printer	8-3
8-5 Solenoid Assembly, Print Head and Character Matrix	8-4
8-6 Operator Control Panel	8-6
8-7 Manual Controls	8-8
8-8 Ribbon Path (Serial Printer)	8-9
8-9 Model 533/536/539 Line Printer (Cabinet open)	8-12
8-10 Operator Control Panel	8-13
8-11 Operational Adjustments	8-16
8-12 Tractor Pressure Plates	8-18
8-13 Paper Alignment	8-19
8-14 Paper Tensioning System	8-20
8-15 Upper Left Ribbon Core Installation	8-20

LIST OF ILLUSTRATIONS (CONT.)

Figure	Page
8-16 Upper Right Ribbon Core Installation	8-21
8-17 Drum Gate with Ribbon Installed	8-21
8-18 Paper Mask Installation	8-22
8-19 VFU Tape	8-23
8-20 VFU Reader	8-24
D-1 Central Processor Control Panel	D-1

LIST OF TABLES

Table	Page
1-1 Supervisor Options	1-10
2-1 Value Table Input Format Entries	2-10
4-1 Operational Considerations Nixdorf To/From Nixdorf	4-19
4-2 Operational Considerations Nixdorf To/From Non-Nixdorf	4-22
4-3 Communications Parameters	4-29
5-1 Code Set Conversion Table	5-19
5-2 Summary Statistics Format (Field Numbers and Lengths)	5-24
5-3 Individual Batch Statistics Format (Field Numbers and Lengths)	5-25
5-4 Check Digit Values for Alpha Characters	5-37
6-1 Data Switch Arrangement for Echo Mode	6-9
6-2A Operator Control Panel Controls and Indicators	6-11

LIST OF TABLES (CONT.)

Table	Page
6-2B Power Panel Controls and Indicators	6-12
7-1 Disk Characteristics	7-5
7-2 Central Control Group Specifications	7-8
8-1 Printer Controls	8-5
8-2 Manual Controls	8-7
8-3 Model 510 Printer Specifications	8-10
8-4 Model 533/536 Printer Controls and Indicators	8-14
8-5 Model 533/536 Fault Indicators	8-15
8-6 Model 533/536 Operational Adjustments	8-16
8-7 Model 533/536 Line Printer Specifications	8-25
8-8 Model 539 Line Printer Specifications	8-26

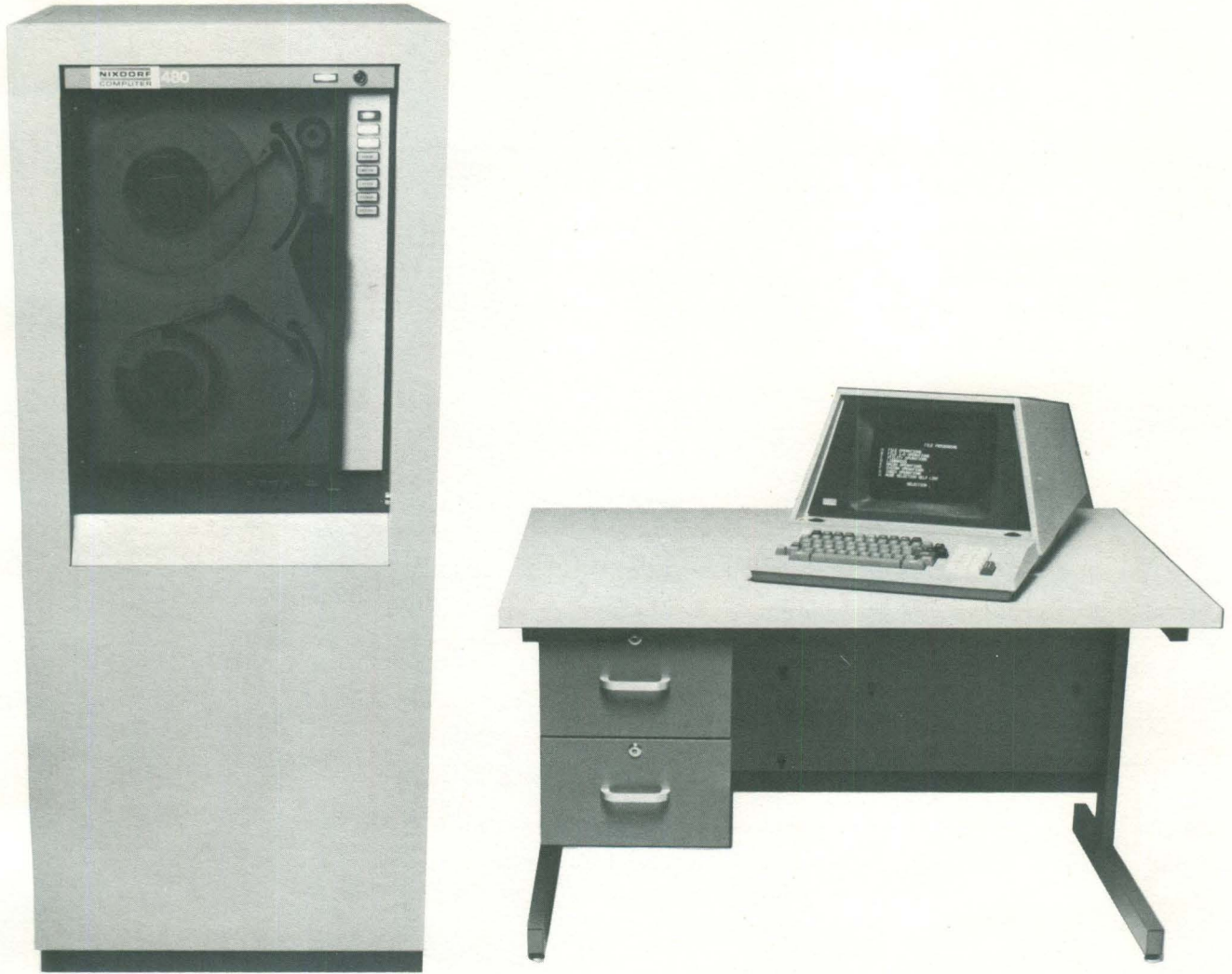
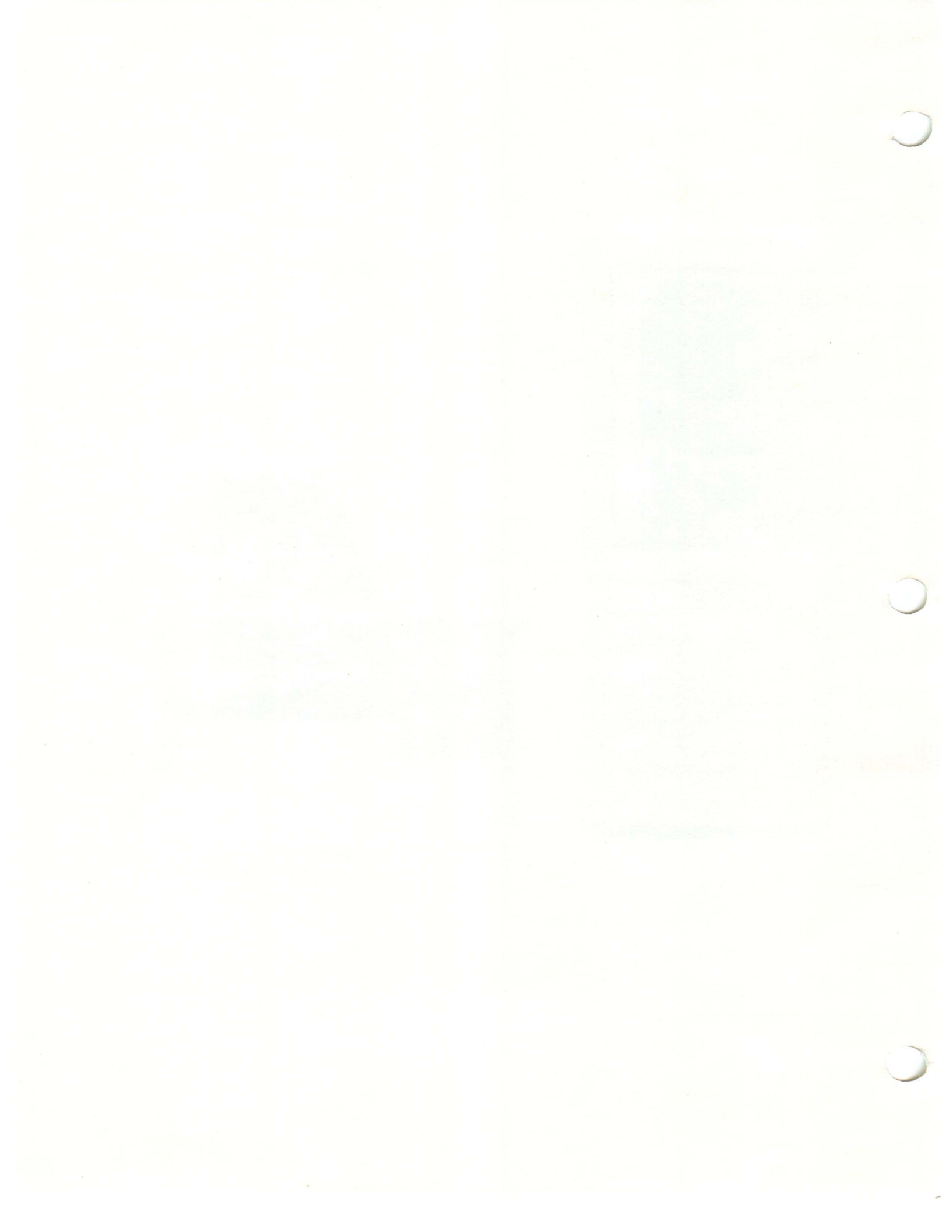

Figure 1-1. Nixdorf System



SECTION 1 SYSTEM OVERVIEW

GENERAL INFORMATION

The Nixdorf 80 Series system (Figure 1-1) is an interactive key-to-disk data entry system and a powerful pre-processor. Data may be input from DATA/TERMINAL* Keystations (either local or remote), tape, card reader, or communications. Data is validated on all levels by a combination of sophisticated input checks, Record End Edits, and Batch Edit programs. Sort programs and Output programs are used to reorder and reformat data before submission for mainframe processing.

The primary method of data entry for the 80 Series system is the DATA/TERMINAL Keystation. As many as 32 Keystations of varying characteristics, i.e., typewriter or keypunch versions, can be driven simultaneously by one System 480 Central Control Group. System 380 may employ up to 22 Keystations and System 280 up to 16. The standard Nixdorf system configuration** consists of:

- DATA/TERMINAL Keystations (up to 32)
 - Data display (CRT)
 - Keypunch or typewriter keyboard
- Central processor
- Central disk
- Magnetic tape unit
- Peripheral devices (optional printers, card reader and communications options).

The 80 Series system produces accurate, formatted and fully edited data for immediate processing by a large business computer or may operate independently as a standalone system (Figure 1-2).

DATA/TERMINAL KEYSTATIONS

The DATA/TERMINAL consists of a TV-like display and separate movable keyboard (see Figure 1-3). The following paragraphs highlight the major features of DATA/TERMINAL Keystations.

*Trademark Nixdorf Computer Corporation.

**For a complete list of 280/380/480 parameters, please refer to Appendix A.

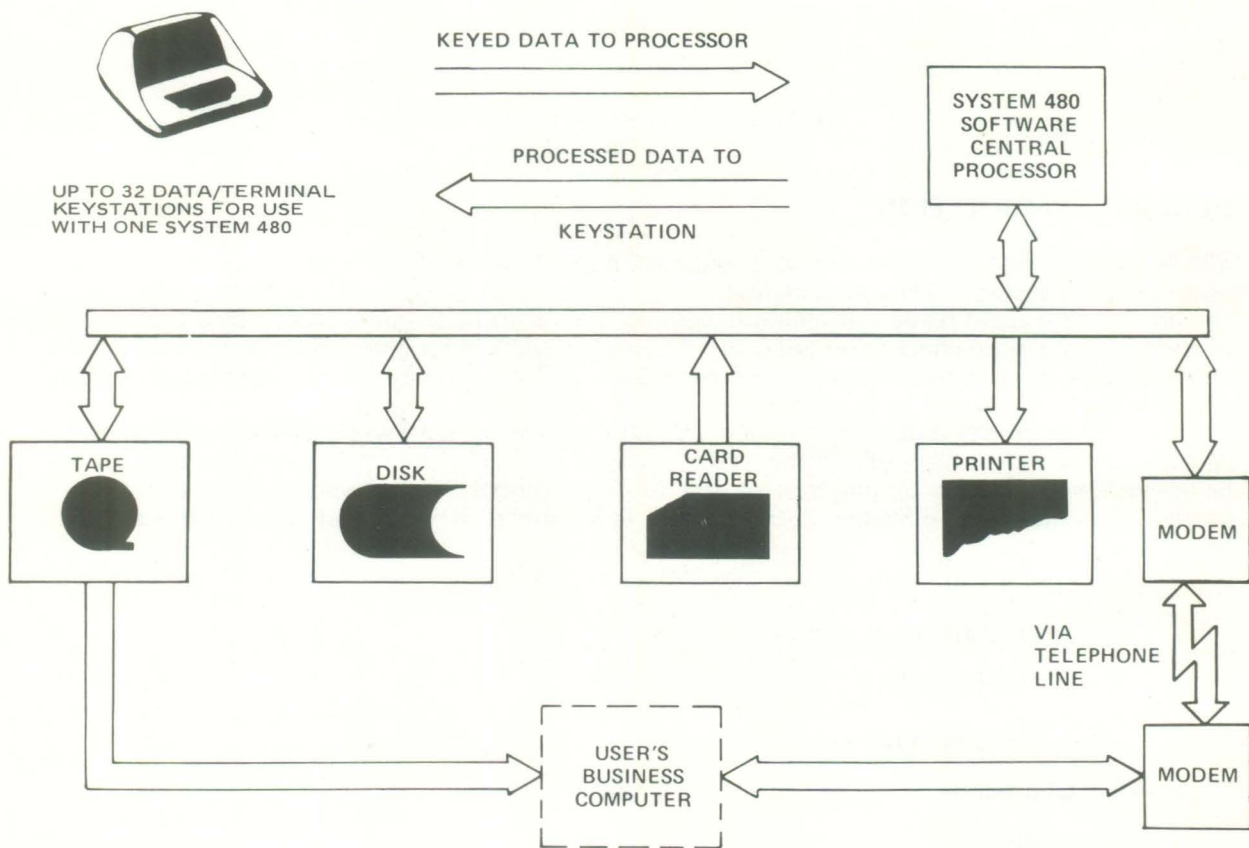

Figure 1-2. System Data Flow



Figure 1-3. DATA/TERMINAL Keystation

Data Display

DATA/TERMINAL Keystations provide the operator with a means of visual and audible communication with the system. The display is capable of presenting a total of 480 (360 for Systems 280 and 380) characters on 12 (9 with Systems 280 and 380), 40-character lines with display presentation sectioned as follows (Figure 1-4):

The first 40-character line (status line) displays the status of the job in progress and includes:

- Mode of Operation - Entry, Verify, Validate, Update, Examine.
- Automatic Function - Indicates whether the automatic functions of duplication, skipping, emitting, incrementing, and automatic record release are ON.
- Input Format Number - The input format number controlling entry of the current record.
- Record Count - A running count of the records maintained by the system under an associated batch name (number). The system maintains the correct record count even if records are inserted or deleted.
- Field Count - The number of the field that the cursor is in within the current record.

The second 40-character line presents diagnostic/error messages as well as messages pertinent to system actions. This line is normally blank, providing a one-line separation between job status and data. When a message is displayed, an audible error tone alerts the operator to the presence of a message.

The remaining 10 (7 with Systems 280 and 380) lines of 40 characters each are used for the presentation of HELP lists, functional option lists, field tags and delimiters, and the associated data to be entered or verified.

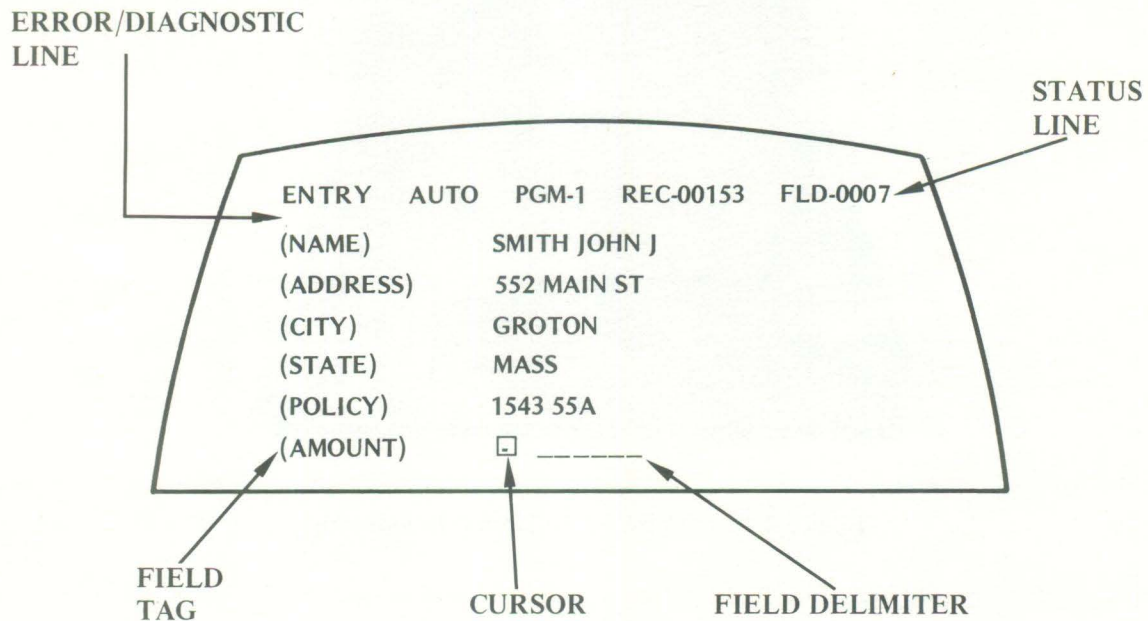

Figure 1-4. Typical Display Presentation

All operator functions are accomplished using the DATA/TERMINAL. The system requests information; the operator keys responses. All displays are in English; memorizing complicated codes or procedures is not required.

Cursor

To aid the user in efficient data entry, a cursor is constantly visible on the data display to indicate the placement of the next data character to be keyed (Figure 1-4). The cursor is a rectangle of light the size of one character that blinks and is transparent; i.e., a character in the same data position can be seen behind it.

Additionally, the cursor can be repositioned backward or forward by character, field or record to allow keying in a different location on the display. Cursor movement in such a manner does not affect the data displayed on the DATA/TERMINAL screen or stored on disk. If more than ten lines are required for entry of a specific record, a scrolling technique is employed. That is, as the eleventh line is displayed, the first line of data on the display rolls up (scrolls) out of the viewing area. Each successive line thereafter causes a top line scroll. It is important to note that the data

lines scrolled off the top of the display are not lost to the operator. In fact, these lines may be re-displayed at any time via a cursor backspace operation. (NOTE: the scrolling technique applies to System 480 only.)

Data Presentation

Data fields are presented to the operator in the form of field tags and field delimiters. Entry of tags and delimiters is accomplished by the supervisor as part of input format creation. Tags and delimiters may be formatted in any desirable fashion; the only criteria are ease of operator understanding and data entry efficiency. Field tags and delimiters are discussed in the following paragraphs and illustrated by Figure 1-4.

- **Field Tags** – Tags are considered a naming convention for data fields displayed on the DATA/TERMINAL screen. Tags are stored in memory with an associated delimiter as a part of the input format and are automatically displayed by the system when records are entered, verified or displayed (Figure 1-4).
- **Field delimiters** – The exact number of data positions corresponding to each field tag is indicated by a row of underscore characters. These characters follow the field tag and form the field delimiter. The delimiter indicates the length of the field as well as the number of remaining characters to be entered by the operator (Figure 1-4).

Audible Signals

Two kinds of audible signals alert the operator to the progress of a job.

- **Field Release Beep** – A quiet, low-pitched “Field Release Beep” informs the operator that work is progressing normally.
- **Error Tone** – A higher-pitched “Error Tone” alerts the operator to the presence of a diagnostic or error message. The keyboard is not operative while the tone is ON, and the RESET Key must be depressed to silence the tone and continue operation.

Keyboard

The keyboard is an integral part of the Keystation. Two keyboards are offered, (see Figures 1-5 and 1-6):

- The keypunch keyboard offers a configuration similar to an 029 keypunch keyboard.
- The typewriter keyboard offers a 12-key numeric group of keys in addition to a conventional typewriter arrangement.

Both keypunch and typewriter style keyboards offer a 64-character repertoire in addition to 16 function keys. The function keys are clearly labeled and allow total interactive system control, as follows:

- AUTO – The automatic function key acts as an ON/OFF switch for the automatic functions of duplicating, skipping, emitting, incrementing, and automatic record release. In addition, the AUTO Key is used in Examine Mode to seek an error flag.
- COR – The correct key, used alone or in conjunction with the FLD or RCD Keys, provides the ability to correct a character, field or record.
- CURSOR LEFT (←) – The cursor left key provides cursor movement in a backward direction. If the cursor left key is depressed, the cursor moves back one space. If the cursor left key is held down, the cursor moves in a backward direction until released or until it reaches the first position of the current record. Using this key in conjunction with the FLD or RCD Keys allows the cursor to move in a backward direction by field or records, respectively.
- CURSOR RIGHT (→) – The cursor right key provides cursor movement in a forward direction. If the cursor right key is depressed, the cursor moves forward one space. If the cursor right key is held down, the cursor moves forward until the key is released or until it reaches the end of the record (auto function OFF) or end of data (auto function ON). Using this key in conjunction with the FLD or RCD Keys allows the cursor to move forward by fields or records, respectively.
- DEL – The delete key provides the ability to delete a character or record.
- DUP – The duplicate key provides the ability to duplicate the contents of the corresponding field of the previous record into the current field. One depression of DUP duplicates one field if auto is ON, or one character if auto is OFF.

NOTE

This function will not operate in Examine Mode.

- FIELD RELEASE – The FIELD RELEASE Key provides the ability to automatically release the cursor from its present field position to the first character position of the next field. When the FIELD RELEASE Key is depressed, the remaining field positions are filled with zeroes or spaces depending on input format specifications for that field.
- FLD – The field key operates in conjunction with the correct key, cursor left (←), and cursor right (→) keys. It acts as a shift key to signify that an accompanying function such as cursor left or correct will apply to the entire field.
- HELP – The HELP Key is the starting point for all operator and supervisor actions. When the HELP Key is depressed, the last HELP List displayed by the system is redisplayed.
- INS – The insert key provides the ability to insert a character or record.



Figure 1-5. DATA/TERMINAL Typewriter Keyboard



Figure 1-6. DATA/TERMINAL Keypunch Keyboard

- LOC RET – The location return key provides the ability to return the cursor to the position held prior to a cursor backspace operation. This feature operates in all modes except Examine Mode. In Examine Mode the cursor is repositioned after spacing backward by depressing the cursor right (→) key or the RCD and cursor right (→) keys.
- OVERSIGN – The oversign key provides the ability to oversign a numeric character (0-9) with a plus (+) or minus (-) sign.
- ^{FMT}PGM – The program key allows the operator to select a desired program level. In addition, use of the program key in conjunction with the HELP or REL Key allows the supervisor to stop operations that run under their own control once initiated, i.e., input, output, and Command Sequence operations.
- RCD – The record key operates in a similar fashion to the FLD Key and operates in conjunction with the correct, insert, delete, cursor left (←), and cursor right (→) keys.
- REL – The release key provides the ability to release the cursor from a field and position it in the next record when keying a data batch or format. It is also used in conjunction with the message, “HIT REL TO PROCEED; OTHERWISE HIT HELP.” This message indicates that the operator has chosen a correct operation and that the operation can continue to the next step of the operator’s sequence. Depression of the REL Key in this instance causes the next level of inquiry to be displayed.
- RESET – The RESET Key is used to alert the operator to a decision pertinent to an error message, i.e., if an error is encountered by the system during keying, an error message is displayed and an error tone is sounded. Depressing RESET turns OFF the error tone and allows the operator to continue operation.

CENTRAL PROCESSOR

A programmed processor is an integral part of the Nixdorf system. The processor controls and validates the data keyed by up to 32 Keystations. Additionally, the processor controls background functions such as communications or tape to print operations concurrent with data entry and verification.

The processor is a highly reliable, versatile, 16-bit minicomputer with 64,000 (48,000 with System 280) bytes of core memory and a memory cycle time of 1.2 microseconds. The following hardware features are standard:

- Four accumulators
- Two index registers
- Direct memory access channel
- Priority interrupt channel
- Power failure protection and automatic restart.

The Central Processor is discussed in detail in Section 7.

CENTRAL DISK

The 80 Series system disk is a random-access fixed disk device used by the central processor for immediate data storage. Data keyed by each operator is stored as a batch on disk and may be re-formatted before being written to magnetic tape or other output device. Files previously written on tape by the system or created by another computer system can be read to disk and stored for processing. Additionally, all program libraries are maintained on disk. Section 7 contains a detailed description of data organization on the 80 Series system.

MAGNETIC TAPE UNITS

Systems 380 and 480 may be configured with 7 or 9-track magnetic tape units which read and write at 25 inches per second. Packing densities of 556, 800 and 1600 bits per inch are available. System 280 may be configured with 9-track tape units with packing densities of 800 and 1600 bits per inch. These configurations are described in Section 7.

All tape units provide industry-standard error checking as well as Beginning Of Tape (BOT) and End Of Tape (EOT) sensors. The tape drives accept a 10½ inch reel, providing up to 2400 feet of tape for use with the system. (System 280 uses an 8½ inch reel with 1200 feet of tape.) Additionally, the 480 system can simultaneously support up to four tape drives of varying characteristics. System 380 can support up to two tape drives.

SUPERVISOR FUNCTIONS

Management of the 80 Series system is accomplished via the Supervisor HELP List. Supervisor Mode is selected from the Operator HELP List to convert any keystation to a supervisor station.

To provide system security, a Supervisor Password feature is included in the system. The Supervisor Password may be entered as any combination of alpha, numeric or special keyboard characters. This password is an exception to the general rule that everything keyed at the Keystation is displayed. To preserve the security of the password, it is not displayed when keyed.

If an incorrect password is entered, the system redisplay the Operator HELP List. If the proper Supervisor Password is entered, the system displays the Supervisor HELP List. The following operations are available via the Supervisor HELP List:

- BATCH OPERATIONS
- LIBRARIES
- BATCH INPUT/OUTPUT OPERATIONS
- PERFORM COMMAND SEQUENCE
- UTILITY OPERATIONS
- SYSTEM OPERATIONS

When one of the above operations is selected by the supervisor, the system displays an appropriate options list. Table 1-1 illustrates the functions available to the supervisor via these lists.

TABLE 1-1. SUPERVISOR OPTIONS

BATCH OPERATIONS	
● DISPLAY STATUS	● SORT
● DISPLAY BATCH LOG	● VALUE TABLES
● EDIT	● BATCH PROTECTION
● DELETE	● VALIDATE
● RENAME*	
BATCH INPUT/OUTPUT OPERATIONS	
● STANDARD JOB OUTPUT	● READ STANDARD JOB
● WRITE BATCH	● READ BATCH
● WRITE BATCH STATUS	● APPEND TO BATCH
● WRITE BATCH LOG	● READ WITH STD JOB HEADER
UTILITY OPERATIONS	
● WRITE TAPE MARK	● SEARCH TAPE FOR SEQUENCE
● WRITE TAPE MARK AND REWIND	● DEVICE FROM TAPE
● REWIND TAPE	● DEVICE FROM CARD READER
● BACKSPACE ONE TAPE RECORD	● COMMUNICATIONS UTILITIES
● SEARCH FOR TAPE MARK	

TABLE 1-1. SUPERVISOR OPTIONS (Cont.)

LIBRARIES	
<ul style="list-style-type: none"> • STANDARD JOB • INPUT FORMAT • RECORD END EDIT • BATCH END EDIT • OUTPUT PROGRAM • SORT PROGRAM 	<ul style="list-style-type: none"> • COMMAND SEQUENCE • CODE SET CONVERSION • OPERATOR STATISTICS • CHECK DIGITS • READ ALL LIBRARIES • WRITE ALL LIBRARIES
PERFORM COMMAND SEQUENCE	
<p>Perform Command Sequence is selected to execute a predetermined keystroke sequence. No options are required under this function; rather, when Perform Command Sequence is selected, the Command Sequence name entered, and the REL Key depressed, the system executes the desired keystroke sequence.</p>	
SYSTEM OPERATIONS	
<ul style="list-style-type: none"> • ENTER DATE • DISK STATUS • SYSTEM SAVE • ASSIGN TAPE UNIT • CHANGE PASSWORD • NUMERIC ONLY EXCEPTIONS 	<ul style="list-style-type: none"> • COMM PARAMETERS • DIAGNOSTIC MODE • SYSTEM TAPE CODE • TYPEWRITER OVERSIGN • OPTIMIZE SYSTEM • AUTO BATCH LOAD • FORMAT DISK

The following sections describe the functions comprising supervisor control of the 80 Series system. The *Supervisor's Quick-Reference Guide* provides visual reference material concerning supervisor activity at the DATA/TERMINAL Keystation.

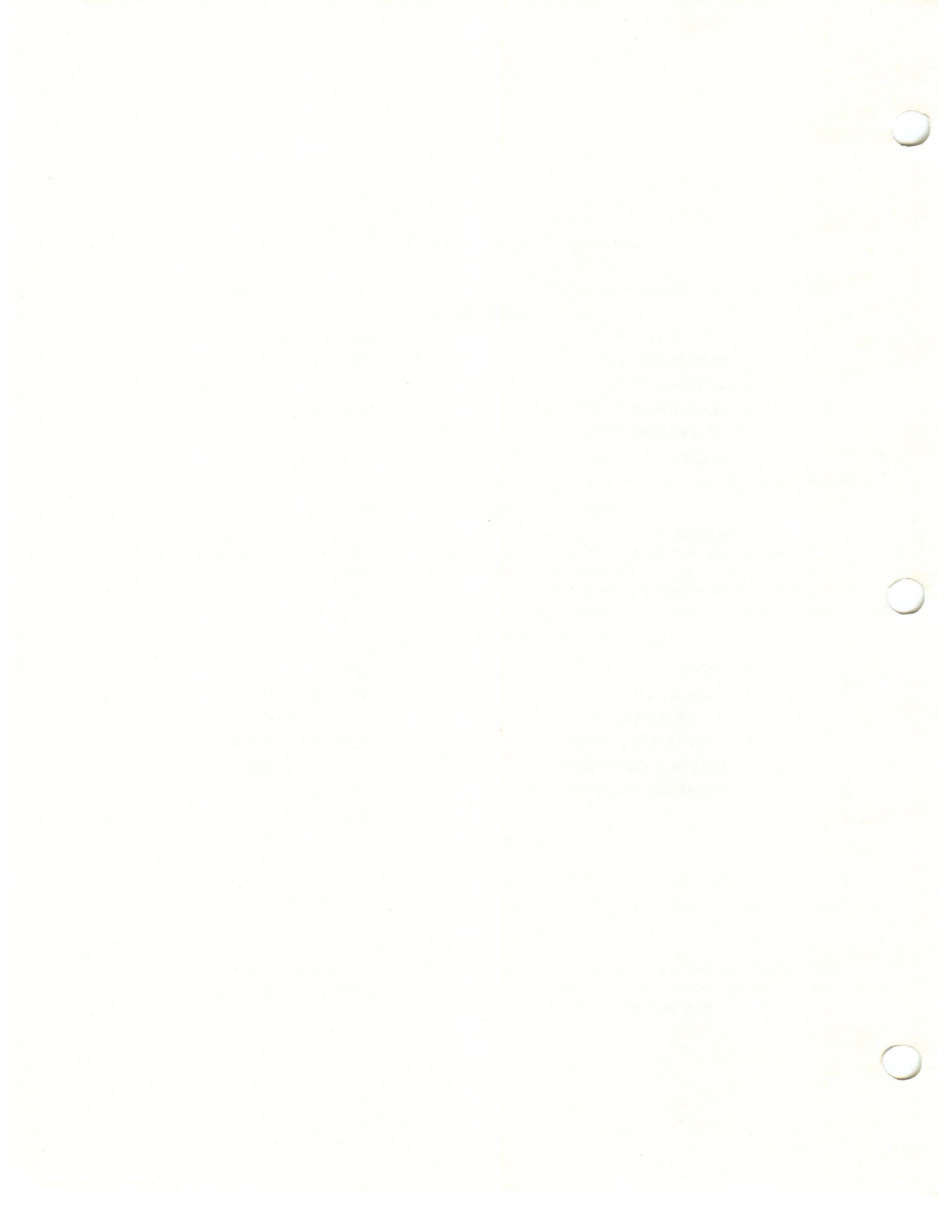

SECTION 2 BATCH OPERATIONS

Batch Operations are supervisory functions used to control a batch or batches residing on disk. The following paragraphs discuss the various options that may be performed via the Batch Operations List.

GENERAL INFORMATION

The following paragraphs discuss system functions which aid the supervisor in performing data management duties associated with the Batch Operations List.

Asterisk Processor

The Asterisk Processor is a system function which allows the supervisor to output, delete, sort, or display associated files/batches, which meet with one naming convention, in one operation. To display all batches beginning with PAY, enter PAY*****. In addition, the Asterisk Processor may be used to output, delete, sort, display, or validate all data contained in a specified file or library in one operation, i.e., to display all data contained in a specified file or library, enter asterisks in all key-positions in response to "ENTER NAME".

AT Processor

The AT Processor is an 80 Series system function which gives the supervisor the option to omit specified information that otherwise would be displayed, written, sorted, or deleted. For example, to delete all batches contained on disk with the exception of those beginning with INV, enter INV followed by @ in all key-positions in response to "ENTER NAME". When this information is entered, the system deletes all batches on disk with the exception of those beginning with INV.

Valid/Invalid Matching Names Display

Since the Display Batch Log, Edit, Delete and Sort options of the Batch Operations List allow the supervisor to affect multiple batches on disk, the system displays Valid/Invalid Matching Names. Valid Matching Names indicate the batches which will be affected by the operation. Invalid Matching Names indicate which of the selected batches will not be affected by the operation. Possible reasons for not affecting the batch are: batch has protection assigned, batch is assigned a value table reference number, or batch is associated with a Sort file.

Program (PGM) HELP

The PGM HELP feature of the 80 Series system enables the supervisor to stop those operations that run under their own control once initiated, i.e., Input, Output and Command Sequence operations.

The PGM HELP feature may be executed at any time during these operations by holding down the PGM Key and depressing HELP. Upon execution of PGM HELP, the system stops the operation.

If an Input/Output operation is stopped, the system displays the number of records affected by the operation thus far. To redisplay the last HELP List displayed by the system, depress the HELP Key.

If a Command Sequence operation is stopped by PGM HELP, keyboard control immediately reverts to the operator. It is important to note, however, that the PGM HELP feature will not stop a Read All Libraries/Write Libraries operation.

DISPLAY BATCH STATUS

The 80 Series system allows the supervisor to display the status of a batch or batches residing on disk. If status information is desired for one batch, the batch name is entered. If status information is required for multiple batches, the Asterisk Processor is used. When the Asterisk Processor is used, the system displays status information one batch at a time in alphanumeric order by batch name. Status information (if applicable) is given for each batch, as illustrated in the following display and explained below:

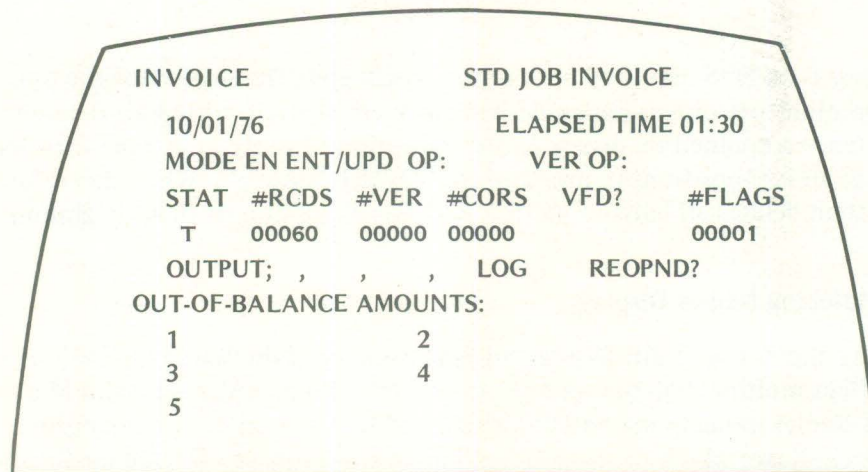

```
INVOICE                STD JOB INVOICE
10/01/76              ELAPSED TIME 01:30
MODE EN ENT/UPD OP:   VER OP:
STAT #RCDS #VER #CORS VFD? #FLAGS
T   00060 00000 00000      00001
OUTPUT; , , , LOG    REOPND?
OUT-OF-BALANCE AMOUNTS:
1                2
3                4
5
```

- Batch name.
- Associated standard job name.
- Date batch was initiated in Entry Mode.

Display Batch Status

Invoice

01/31/84

Std Job Invoice

Elapsed Time 01:30

Mode EN ENTIUPD OP: _____ VER OP:

STAT # RCDS # VER # CURS VFD? Flags

T 0006 0000 0000

OUTPUT: , PR , Log Reopnd?

Out-of-Balance Amounts

₃

Display Batch Status

1
2
3
4
5
6
7
8
9
10
11
12
13
14
15
16
17
18
19
20
21
22
23
24
25
26
27
28
29
30
31
32
33
34
35
36
37
38
39
40
41
42
43
44
45
46
47
48
49
50
51
52
53
54
55
56
57
58
59
60
61
62
63
64
65
66
67
68
69
70
71
72
73
74
75
76

Invoice
Classed Time 01:30

Mode FN FUTURE OF VER OP

STAT # RCDZ # VER # CURS VERD: [unclear]

T 0000 0000 0000

OUTPUT: PR, Lod
Reopenys

OUT-OF-Balance Amounts

- Elapsed Time – The time consumed in the batch.
- Mode – The last mode in which the batch was open.
- ENT/UPD OP/VER OP – The identification of the last entry and verify operators.
- Batch Status (STAT) – The current status of the batch: (A) indicates the batch is active; (I) indicates the batch has been interrupted; (T) indicates the batch has been terminated; (V) indicates the batch has been assigned a value table reference number; (S) indicates the batch is being utilized by a Sort Routine.
- #RCDS – The number of records entered in the batch.
- #VER – The number of records verified in the batch.
- #COR – The number of times the COR Key was depressed during verification.
- VFD? – If the number of records verified is equal to or greater than the number of records entered, the system places a Y under VFD?.
- #FLAGS – The number of error flags remaining in the batch.
- OUTPUT – An indication that the batch was written and the output device used.
- LOG – An indication that an associated batch log exists for this batch.
- REOPND? – An indication that the batch was reopened *only* after being written to computer-legible media. Note – the system will not indicate a Y if output is to other than tape, communications, or computer-legible media.
- An indication of the “out-of-balance amounts”.

The Display Batch Status feature works in conjunction with the Batch Protection feature of the 80 Series system; that is, the supervisor can specify that the status of batches residing on disk be displayed *only* when batches meet the requirements set on the Batch Status Requirements Page (refer to Batch Protection, page 2–13). For example, if the supervisor specifies that batches be terminated, all requests to view the status of batches *not* terminated will be rejected, until batches are terminated or the batch protection requirements are changed.

NOTE

If the supervisor is viewing the status of a batch that an operator is attempting to use, the message “ATTEMPT TO MODIFY ‘IN-PROCESS’ FILE” is displayed by the system at the operator’s terminal. Once the supervisor completes the status display function, the operator may use the batch name.

In addition to allowing the supervisor to display the status of batches residing on disk, the 80 Series system allows the supervisor to write to tape or print status information. These functions are performed via the Batch I/O Operations List (refer to Section 3).

DISPLAY BATCH LOG

Display Batch Log allows the supervisor to display error messages and/or other data associated with a batch or batches residing on disk. Batch logs are created during Batch Edits using the OUTPUT statement. Once created, batch logs are assigned the same name as the batches being entered.

The information listed is entirely at the supervisor's discretion; however, a typical listing might include:

- Record number
- Field name or number
- Erroneous values entered
- The correct value.

If a batch log display is desired for one batch, the batch name is entered. If a batch log display is required for multiple batches, the Asterisk Processor is used. To enable the supervisor to determine which of the selected batch names have an associated batch log, the system displays "Valid/Invalid Matching Names" in alphanumeric order. Once the supervisor has reviewed and released the "Valid/Invalid Matching Names" displays, the system displays the actual batch logs in alphanumeric order.

BATCH EDITS

The Batch Edit feature within the Batch Operations List allows the supervisor to execute an established Batch Edit program at will. An edit program may be selected to affect one batch, or multiple batches via the Asterisk Processor; however, batches selected for processing must be *terminated* (closed-out at a keystation). To enable the supervisor to determine which of the selected batches are valid for processing, "Valid/Invalid Matching Names" are displayed in alphanumeric order. Once the supervisor has reviewed and released the "Valid/Invalid Matching Names" display, the system executes the Batch Edit program.

NOTE

The Batch Protection Requirements for output will prohibit execution of a Batch Edit, if the batch to be edited does not meet with the specified Batch Protection Requirements for output (refer to Batch Protection, page 2-13).

The Batch Edit and Batch End Edit features of the 80 Series system perform identical tasks. Both edits use identical language statements and are stored in the same library (Batch End Edit Library). Both are executed as an error detection routine to check or validate data.

The single difference between the Batch Edit and Batch End Edit features is the time of execution, as follows:

- Batch End Edits – These edits are performed at batch termination in any mode. Immediately after a batch is terminated (not interrupted), the system performs all specified Batch End Edit operations.
- Batch Edits – These edits are executed *at will* by the supervisor and via */@ processor. For example, the supervisor might use this feature to perform Batch Edits on all data keyed by the operators during the normal working day. Such an operation, performed in the evening, would alleviate the time required to perform Batch End Edits, thus allowing the operators more time to enter data.

NOTE

A detailed discussion of Batch Edits is contained in the "80" Series Formatting Techniques Manual.

DELETE A BATCH

The 80 Series system allows the supervisor to delete a single batch or multiple batches, via the Asterisk Processor, from disk. To insure that a batch is not inadvertently deleted, the system displays "Valid/Invalid Matching Names" in alphanumeric order. A delete request for a batch or batches will be displayed as invalid if:

- The batch to be deleted does not meet with specified Batch Delete Requirements (refer to Batch Protection, page 2–13).
- The batch has been assigned a value table reference number. To delete the batch, remove the batch name from the value table assignment (refer to Value Tables, page 2–7).
- The batch is being used as input to a Sort file. To delete the batch, the Sort file must be deleted (refer to Sort, page 2–6).

RENAME A BATCH

With the Rename A Batch feature, a batch on disk may be renamed by the supervisor. To rename a batch on disk, simply select Rename from the Batch Operations List and enter the new (desired) batch name as well as the existing batch name. When the renaming statement is released, the batch is renamed.

WARNING

Care should be taken when utilizing this feature. The Supervisor should insure that such a change is documented. The 80 Series system does not keep a record of the change, and any future attempt to call up the batch utilizing the old name will be disallowed by the system.

SORTS

The 80 Series Sort capability allows the supervisor to sort records within one or more batches, residing on disk, to form a file of sort keys (Sort file) on disk. The Sort file consists of a sequence of sort keys and associated disk addresses as follows:

- Sort Keys – A field or sequence of fields in a record. Any field or sequence of fields can be specified as the Sort key. There is no restriction on the number of operands specified; however, the total number of characters within one sort key cannot exceed 200.
- Disk Addresses – Disk addresses act as pointers and indicate the disk locations of the records containing the keys.

The Sort file is held on disk under a ten-character name (Sort file name) until the sorted output is obtained and the supervisor deletes the Sort file. Usually a Sort file is deleted as soon as the desired output is obtained.

Sort files are established on disk by the execution of a Sort Program. Sort Programs are coded on Nixdorf system Editor Coding Forms using the Editor language and stored in the Sort Program Library.

Batches can be sorted in ascending or descending order. The Sort feature is part of the Editor language, and it has access to all language instructions except OUTPUT. Data can be validated as it is sorted; errors can be flagged, or the sort can be terminated immediately if the sort does not meet specified requirements. Figure 2-1 illustrates the effect of a Sort Program (INVSORT) (“80” Series Formatting Techniques Manual) on input data.

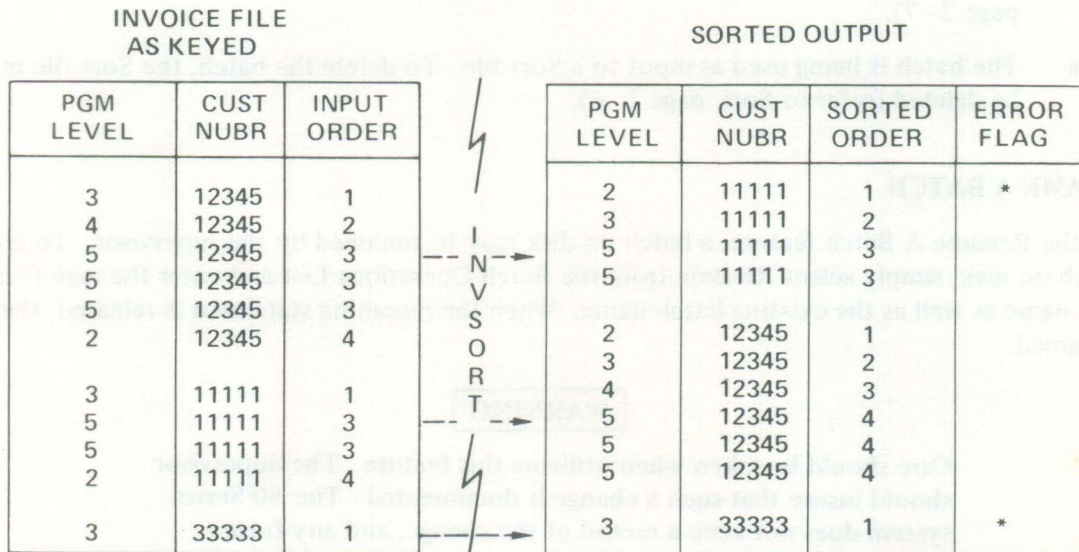

Figure 2-1. Sort Program “INVSORT”

NOTE

Input data is stored on disk only once; Sort Programs do not duplicate data, but simply build a sort file containing keys and disk addresses. The supervisor should remember that building a sort file utilizes disk space. Therefore, the available disk space should always be checked prior to executing a Sort (refer to Disk Status, page 6-1).

Execution of a Sort Program is accomplished by selecting the Sort feature from the Batch Operations List. Once selected, the supervisor must enter the Sort Program name; the code set, if other than the default code set; the name to be assigned the Sort file; and the name of the batch or batches (via the Asterisk Processor) to be used as input to the Sort file. Once this information is entered and the REL Key depressed, the system displays "Valid/Invalid Matching Names" in alphanumeric order.

The "Valid/Invalid Matching Names" display allows the supervisor to review which of the selected batches are valid for processing. If one or more of the selected batches is displayed as *invalid*, the supervisor should check the following:

- Sort Program execution works in conjunction with Batch Protection Requirements for Output (refer to Batch Protection, page 2-13). Should selected batches fail to meet the specified requirements, the supervisor should check the batches against the specified requirements and correct any deficiencies in the batches, or remove the specified output requirements affecting the operation.
- If batches displayed as *invalid* are assigned a value table reference number, the supervisor must remove (unassign) the batch names from the value table reference number list prior to executing a Sort Program using those batches.

Once the "Valid/Invalid Matching Names" displays are released, the system executes the Sort Program and builds a Sort file on disk. Additionally, during a Sort operation, the pass and number of remaining inversions are displayed. During the Sort's last pass, the display reads "FINAL PASS IN PROGRESS".

NOTE

As previously stated, Sort files do not contain data, but pointers to data. For this reason, Sort files may not be displayed on the DATA/TERMINAL. Once the Sort file is written to tape via a batch output operation, the sorted output may be read into the system as a batch or batches on disk, printed or communicated. However, sorted files can be displayed via a Batch Edit Program run that "SHOWS" or "PAUSES" <ALL>.

VALUE TABLES

The Value Table feature of the Batch Operations List allows the supervisor to assign a value table reference number to a batch or batches residing on disk. Up to 20 batches with Systems 380 and 480 and seven batches with System 280 may be assigned a value table reference number at any

one time. In addition to this assignment capability, batch names assigned a value table reference number can be displayed for supervisor review, unassigned from the value table reference number list, or reassigned within the list.

Use of Value Tables allows data fields entered by an operator to be validated by comparing them with value table entries (batches) stored on disk. Data validation via the Value Table feature is performed at field end time.

The 20 value tables provided by the 80 Series system can be conveniently divided into two categories for discussion: standard value tables, and indexed value tables. These two groups of value tables differ in search methods, interpretations of input format specifications, and the functions performed after validation.

Standard Value Tables

Entered data is tested against a value table batch in one of two methods:

- Valid Entries (system performs inclusive test) – If data entered by an operator corresponds to data in the value table batch, that data is valid.
- Invalid Entries (system performs exclusive test) – If data entered by an operator corresponds to data in the value table batch, that data is invalid.

The test method to be used for a value table lookup is specified in an input format within the Input Format Library. If the test method is not specified, the system defaults to the *valid entries* test method.

In addition to the two test methods, three search methods may be used during value table operation. A search may be initiated in either ascending, descending or random order depending on the application and the order in which the entries within the value table batch are keyed. Figure 2–2 illustrates the entry and search methods associated with a value table batch.

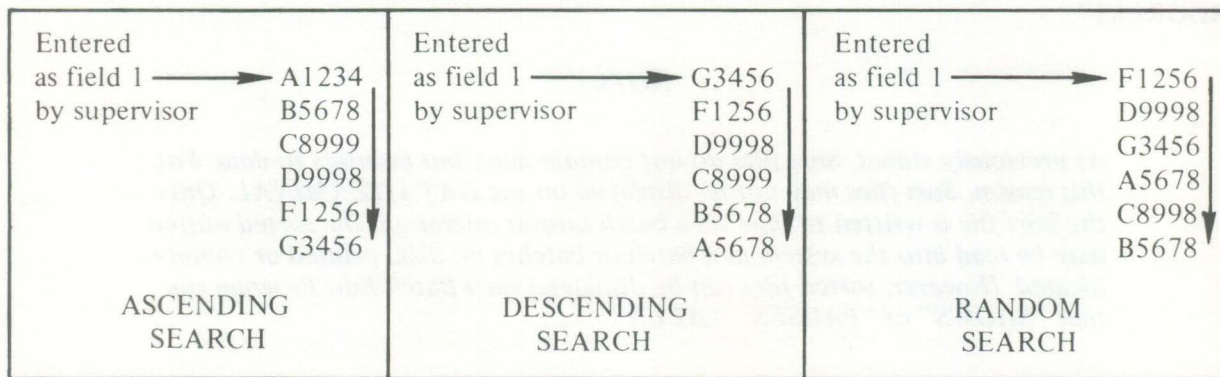

Figure 2–2. Example of Value Table Batch Entered by Supervisor

When the Value Table feature is activated by an operator entry, the value table batch is scanned. The system will exit (discontinue) an ascending/descending search when a corresponding value is located, or, if not located, when a higher (ascending search) or lower (descending search) value is encountered. The system discontinues a random search when a corresponding value is located, or the end of the data is reached.

It is important to note that the supervisor creates a value table batch with a specific application and search method in mind. For example, if there is a discernable frequency of specific data being entered by the operator, a random value table batch, based on that knowledge, would be created by the supervisor, and the random search method would be specified. If no discernable frequency is indicated by the application, either an ascending or descending order is used to enter data within the value table batch, and the corresponding search method is specified for the operation.

Value table batches may be alpha-only, numeric-only, or may contain spaces and special characters; however, the Value Table feature is ordered to accept the following character priorities:

ASCENDING SEARCH	DESCENDING SEARCH
1 – Space/Special characters	1 – Numeric characters
2 – Alpha characters	2 – Alpha characters
3 – Numeric characters	3 – Space/Special characters

Therefore, when value table batches contain a variety of character types, the supervisor must assign the correct search method to insure that the search is not prematurely discontinued.

The use of long value tables is time consuming because of the disk access involved; therefore, the supervisor should insure that the Value Table feature is required for a specific application, and that value tables are not being used exclusively where a range check might be substituted or where a value table and a range check might be combined.

Indexed Value Tables

The Indexed Value Table feature provides fast access to very large value tables stored on disk, with table length limited only by the storage capability of the 80 Series system.

When a batch is assigned as one of the value tables, the system constructs an index containing the disk location of selected records in the batch. This index is constructed immediately upon assignment of the batch as a value table; the time initially required to generate the index may cause a delay, depending on the batch size.

NOTE

The indexed value table entries must be physically in ascending order.

This access method may be used for normal validation; in addition, information stored in a *corresponding field* in the value table may be either *displayed* on the screen or *replaced* into the next field(s) of the input record being keyed.

Indexed Value Table Batch Format

When using the Indexed Value Table feature, the first field in the value table batch is the look-up key. The corresponding field (display/replace field) immediately follows the key field and should be a different length (up to 99 characters long). All entries must be in ascending order with no deleted records.

Sample Value Table Entry:

A2728	CORRESCOPE	
Key Field (<i>catalog no.</i>)	Corresponding Data Field (<i>description</i>)	

Indexed Value Table Operation

The mechanism for value table look-up, display, and/or replace is located in the input format. To utilize an indexed value table, specify one number in answer to the value table number question. The valid/invalid question is used only on a look-up/validate function and the order (A, D, R) question entries assume new meanings when the indexed value table option is used. Table 2-1 illustrates these new meanings.

TABLE 2-1. VALUE TABLE INPUT FORMAT ENTRIES

ENTRY	MEANING (Standard Value Tables)	MEANING (Indexed Value Tables)
A	Value Table entries are in ascending order.	System validates the entry, but with much higher access speed. Table is assumed to be in ascending order.
D	Value table entries are in descending order.	System looks up the entry in the value table and <i>displays</i> the corresponding field on the screen starting at line 2, col. 1. Table is assumed to be in ascending order.
R	Value table entries are in random sequence.	System looks up the entry in the value table and <i>replaces</i> (enters) the corresponding field into the entry record using as many fields as necessary. Table is assumed to be in ascending order.

FILE NAME: LISTBHB

ENTRY/UPDATE
11/22/82
DATE: 11/22/82
TIME: 0:20
GROSS KEYS 3762
NET KEYS 3493
GROSS RATE 11286
NET RATE 10479
RECORDS 100

COMPARISON CHART FOR LISTBHB 11/22/82 PAGE 1

ALS GAS CO	2032 GRAND AVE	DALLAS TEXAS	2345109
ALS GAS CO	2032 GRAND AVE	DALLAS TEXAS	2345409 ✓
CARNEY RICHARD	13 E ARMY	DALLAS TEXAS	2573096
CARNERY RICHARD	13 E ARMY	DALLAS TEXAS	2573096 ✓
EASTMANN CHARLES	909 GRAND DRIVE	DALLAS TEXAS	2669178
EASTMANN CHARLES	909 GRAND DRIVE	DALLAS TEXAS	2669176 ✓
EASTON PAULINE	50981 SCENIC DRIVE	DALLAS TEXAS	WH59876
EASTON PAULINE	50981 SCENIC DRIVE	DALLAS TEXAS	WH59873 ✓
GITTMANN JUDITH	24198 MACKINLEY	DALLAS TEXAS	NE88808
GITTMANN JUDITH	24198 MCKINLEY	DALLAS TEXAS	NE88808
LAFREZ J I REV	18097 NEOLA	DALLAS TEXAS	2459876
LAFREZ J I REV	18097 NEOLA	DALLAS TEXAS	2469876 ✓
MATHERN IVAN BE	2615 ROW N 234	DALLAS TEXAS	3486717
MATHERN IVAN B	2615 ROW N 234	DALLAS TEXAS	3486717
PETERSON KENNETH	23398 TERRAC	DALLAS TEXAS	9663369
PETERSON KENNETH	23398 TERRACE	DALLAS TEXAS	9663369

NO OF ERRORS FOR EACH FIELD .
FLD1 FLD2 FLD3 FLD4
2 2 4
TOTAL NUMBER OF ERRORS IS 8

- If A (validate only) is specified, the system functions in the same manner as standard value tables but with a considerably higher access speed. No corresponding field is assumed to be defined.
- When D (display) is specified, the corresponding field is displayed on the screen, beginning in the error message line and continuing, if necessary, in the first and second data lines. Therefore, for long displays, the input format should be constructed with data fields beginning on the second or third lines to avoid overlapping with the displayed field. The corresponding field is displayed exactly as stored in the value table. If there is no corresponding value table field, the message "NO CORRESPONDING FIELD" is displayed.
- When R (replace) is specified, the corresponding value table field is entered into the current input record in the field(s) immediately following the current field. The display of these fields may be formatted with tags, and the fields thus created *are* available to a Record End Edit following record release.

If R is specified in the input format and no corresponding value table field exists, the message "NO CORRESPONDING FIELD" will be displayed. If the corresponding value table field requires more positions than remain to be filled in the current data record, the message "INPUT AND BATCH RECORDS NOT EQUAL" will be displayed and the right-most characters of the corresponding field will be truncated. If the corresponding field is shorter than the field to be filled, the right-most positions of the data field will be space-filled.

A field end check is performed only on the last field created through value table look-up. This field is checked for a value table specification, and may therefore contain another key for access into the same or into another value table. In this manner, data of more than 99 characters may be displayed on the screen or replaced into the current record through contiguous value table look-ups.

Value Table Operation Procedures

The following procedure is used to create a value table batch and assign the batch a value table number:

1. If an input format does not already exist in the Input Format Library, create an input format to control the entry of the value table batch.
2. Enter the value table batch. The batch may be manually keyed or the Read A Batch function can be used to enter the batch.
3. Assign a unique value table reference number to the value table batch by selecting Value Tables from the Batch Operations List and selecting Assign from the Value Tables Options List. Once Assign is selected, the value table reference number and batch name to be assigned to that number must be entered.
4. When the REL Key is depressed, the system displays the batch name beside the assigned value table reference number on the following display:

VALUE TABLES	
01	02
03	04
05	06
07	08
09	10
11	12
13	14
15	16
17	18
19	20

NOTE

When a long batch is assigned as an indexed value table, a noticeable time lapse may occur before this display appears on the screen — due to the time required to generate the index.

The following procedure is used to remove (unassign) a batch name from a value table reference number assignment:

1. Select Value Tables from the Batch Operations List.
2. Select Assign from the Value Tables Options List.
3. Enter the value table reference number to which the batch is assigned.
4. Field release through the batch name question displayed on the screen.
5. Depress the REL Key. The system displays the value table reference numbers and associated batch names, *less the batch name which was unassigned.*

NOTE

To reassign a batch name within the value table reference number display, follow the procedure for assigning a batch to a value table reference number. Once the batch has been assigned a new number, remove the batch name from its old assignment by following the procedure for unassigning a batch.

The following procedure is used to display the value table reference numbers and associated batch names:

1. Select Value Tables from the Batch Operations List.
2. Select Display from the Value Tables Options List.

3. When the Display option is selected, the system displays the value table reference numbers and associated batch names. When the HELP Key is depressed, the system displays the Batch Operations List.

NOTE

A further discussion of the use of the Value Table feature as pertains to the input format is contained in the "80" Series Formatting Techniques Manual.

BATCH PROTECTION

Because the 80 Series system provides the ability to affect several batches at one time via the Asterisk Processor, the system contains a Batch Protection feature. This feature provides the supervisor with a means of insuring that batches are not inadvertently deleted, written to tape, printed, sorted, or communicated and allows the supervisor to specify individual batch protection requirements for two distinct categories: *output* and *deletion*. Additionally, the supervisor may specify whether the specified requirements *must* or *must not* be met prior to output or deletion of a batch.

When Batch Protection is selected from the Batch Operations List, the system displays the Batch Requirements Page, as presented below:

```

                                     BATCH PROTECTION
A  BATCH DELETE REQUIREMENTS
B  BATCH OUTPUT REQUIREMENTS
C  BATCH STATUS REQUIREMENTS
                                     SELECTION 
```

If the supervisor wishes to protect batches from being inadvertently deleted, (A) BATCH DELETE REQUIREMENTS is selected; if it is desirable to protect batches from an output operation, (B) BATCH OUTPUT REQUIREMENTS is selected. When either of these selections is made, the following display appears.

BATCH MUST	MUST NOT:
<input type="checkbox"/>	HAVE BEEN WRITTEN HAVE BEEN PRINTED BE TERMINATED BE VERIFIED CONTAIN BATCH LOG HAVE BEEN REOPENED CONTAIN ERROR FLAGS BE OUT OF BALANCE
(KEY X BEFORE DESIRED REQUIREMENTS)	

This display allows the supervisor to set individual requirements which will protect a batch or batches, residing on disk, from a delete or output operation. For example, the supervisor may set output requirements so only verified batches, having no error flags, are included in the output operation. Conversely, delete requirements may be set so that all batches that have been written are included in a delete operation.

The supervisor selects only those requirements that apply to a particular application at a particular time. As requirements change, the protection requirements may be changed. In effect, the supervisor can configure the individual protection requirements to meet the changing demands of specific applications.

In addition to providing a means of protecting batches, the 80 Series system provides a convenient list of requirements by which the supervisor can limit the output of batch status information.

To set the requirements for batch status output, select BATCH PROTECTION from the Batch Operations List and (C) BATCH STATUS REQUIREMENTS from the Batch Requirements Page. Once these options are selected, the system displays the same list of requirements displayed for *output* and *delete*.

Utilization of this list allows the supervisor to specify the requirements which *must* or *must not* be met prior to obtaining requested batch status information. For example, the supervisor may set requirements so that the status of all batches which are out-of-balance may be obtained. This feature, when used efficiently, is an invaluable tool in everyday data control and overall system management.

NOTE

Batch protection parameters entered under BATCH OUTPUT PROTECTION REQUIREMENTS also apply to batch edits and sorts.

SECTION 3 BATCH INPUT/OUTPUT OPERATIONS

Batch Input/Output Operations are supervisory functions used to process data read into the system from a tape, communications, or other peripheral input device, or written to tape, printed or communicated in an output operation. The following paragraphs detail the various options that may be performed via the Batch Input/Output Operations List.

STANDARD JOB OUTPUT

Standard Job Output performs the same functions as the Write A Batch feature of the 80 Series system, the difference being that Standard Job Output uses the output information stored in a specific Standard Job Definition selected from the Standard Job Library, rather than requesting the information from the supervisor.

Output of a standard job requires entry of the standard job name, and the batch or batches to be affected by the output operation. If more than one batch is to be affected, the Asterisk Processor is used. To enable the supervisor to review which of the selected batches are valid for processing, "Valid/Invalid Matching Names" are displayed by the system in alphanumeric order. When the output statement is released, the output operation is initiated by the system.

WRITE A BATCH

The Write A Batch feature of the 80 Series system enables the supervisor to write a batch or batches to tape, communications, or printer. To execute this feature, the supervisor must manually specify (enter) the output requirements illustrated and discussed below:

BATCH I/O OPERATIONS

- 1 OUTPUT DEVICE ___
- 2 RECORD SIZE _____
- 3 BLOCK SIZE _____
- 4 FIXED LENGTH (Y/N)? _
- 5 BLOCKED RECORDS (Y/N)? _
- 6 CHARACTER COUNT _____
- 7 PADDING/SKIP CHARACTER ___
- 8 CODE SET _____
- 9 OUTPUT PROGRAM _____

- Output Device – The desired output device must be entered. Either a tape drive, printer or a communications device may be specified. If a tape drive “T n ” is selected for output, the desired tape drive must be specified ($n = 1$ through 4). Data entry centers have different tape drive assignments; however, the following is a typical tape drive assignment:

- Tape Drive 1 – 9-Track, 800 bpi,
- Tape Drive 2 – 9-Track, 1600 bpi,
- Tape Drive 3 – 7-Track, 800 bpi with even parity,
- Tape Drive 4 – 7-Track, 800 bpi with odd parity.

If a printer is selected, “PR” is entered. If a communications device is selected to transmit data between Nixdorf systems, “CM” is entered. If it is desirable to transmit data from a Nixdorf system to a 2780-type terminal via a communication device, “RE” is entered. To transmit data in conformance with preset communications parameters, enter “TC”.

- Record Size – Record size indicates the number of characters in each record. Records may be either fixed length (each record having the same number of characters) or variable length. If records are to be fixed length, enter the appropriate number of characters beside “Record Size”. If records are to be variable length, the size of the *largest* record is entered beside “Record Size” (or left blank to default to Buffer Size).
- Block Size – Depending on the application, it may be more efficient, i.e., magnetic tape and mainframe time, to block records. If this procedure is desired, the block size should be entered beside “Block Size”. To obtain the block size for a fixed length record, multiply the fixed length record size (number of characters) times the number of records being blocked. If blocks are to be variable length, the size of the *largest* block should be entered beside “Block Size” (or left blank to default to Buffer Size).
- Fixed Length – If records being entered are fixed length, “Yes” (Y) should be entered beside “Fixed Length”. If the records are variable length, field release through this field (defaults to “No”).
- Blocked Records – If “Yes” (Y) is entered for this option, as many records as possible will be included in each output block. If “No” (N) is entered, individual records will be written as separate blocks.
- Character Count – Character count indicates the number of characters contained in the current record to be inserted into the output record. The count may be in binary or decimal digits and is specified by coding B, D or S in the correct position. Examples of character count are:
 - DDSS – Two-digit decimal count with two trailing pad/skip characters,
 - BBSS – Two-digit binary count with two trailing pad/skip characters,
 - DDD – Three-digit decimal count,
 - SSBB – Two-digit binary count with two leading pad/skip characters.

- **Padding/Skip Character** – If fixed length, blocked records are specified, and all the positions are not used in the last block, a padding/skip character will be used. For example, if the last block in a 400-character fixed length block sequence contains only two 80-character records, the remaining 240 positions would be filled with a padding/skip character. The padding/skip character for 9-track tapes can be either:
 - Two hexadecimal digits, or
 - A space followed by any desired keyboard character.
- **Code Set** – Various code sets are used by different mainframes, however, the standard code set for the 80 Series system is EBCDIC. If no code set is entered, the system defaults to EBCDIC or to the system code set. If another code set is required, it must be coded and entered in the Code Set Conversion Library (Libraries List). If 7-track equipment is being used, EBCDIC *cannot* be used and a code set *must* be entered.
- **OUTPUT Program** – The program name which will be used to output the data must be entered.

NOTE

Record size, Block size, Fixed Length, Blocked Records, Character Count, Padding/Skip characters, and Code Set apply to tape output only. For output to other devices, RCD-T (tab) can be depressed after entering the Output Device, and the cursor will be positioned to Output Program.

Once the output requirements are entered, the batch name(s) must be entered. If more than one batch is to be written, the Asterisk Processor is used. To enable the supervisor to review those batches valid for processing, “Valid/Invalid Matching Names” are displayed in alphanumeric order. Once the output statement is released, valid batches are output.

WRITE BATCH STATUS

The Write Batch Status feature of the 80 Series system allows the supervisor to output the status of a batch or batches residing on disk to tape or printer. Status information obtained during this operation is identical to that displayed via the Display Batch Status feature of the Batch Operations List. To output batch status information for a single batch, enter the batch name; if the status of more than one batch is desired, the Asterisk Processor is used. To enable the supervisor to review which of the selected batch names are valid for processing, “Valid/Invalid Matching Names” are displayed in alphanumeric order. Once the output statement is released, the system initiates the output operation.

or CRT), enter the names of associated batches via the Asterisk Processor, and the code set name, if other than the standard code set, to be used. As with other output operations, "Valid/Invalid Matching Names" are displayed in alphanumeric order. When the output statement is released, the output operation is initiated.

NOTE

Batch logs are written to tape in the form of 40-character records.

READ STANDARD JOB

The Read Standard Job feature of the 80 Series system provides the ability to read files contained on magnetic tape (via a communications, remote entry, remote batch, or local tape-in operation) or on punched cards (via a local card reader operation), onto disk. This feature is used when data being read in does not contain a standard job header, and if a standard job defining the batch into which the data will be read exists in the Standard Job Library. Since standard jobs contain the associated input formats and edit programs for records within the job, the supervisor is not required to manually enter *input format linkage* information.

Execution of a Read Standard Job operation requires the selection of the desired input device (tape, communications, remote entry, remote batch or card reader) and entry of the standard job name and batch name. Additionally, the code set name (if other than the default code set is to be used in the operation), the number of records to be read, and the combined linkage questions must be answered.

Conditional linkage is entered as a (Y) yes, (N) no, or (P) program select. The way in which the conditional linkage question is answered determines the method for selecting record formats, as follows:

- Yes (Y) – *Conditional format selection is to be used.* The system uses the first character of each data record read into the system to determine the specific input format (program level) number to control the record. Therefore, the first position of each data record must contain a character indicating the program level controlling input.
- No (N) – *Conditional format selection is not desired.* The records will be read in a fixed sequence corresponding to the *links to information* of the standard job definition. If *links to information* does not exist, records are read under program level one (1).
- Program Select (P) – The first position of each record will contain a character equal to the program level number of the input format to control the record. After selection, the first character is discarded. Utilization of this conditional linkage method allows a program selection character to be added at output and then deleted during input.

When the required information for a Read Standard Job operation is entered and the REL Key depressed, the system executes the input operation. At the completion of the read operation, the system displays the number of records read into the system during the operation.

READ BATCH

The Read Batch feature enables the supervisor to read a batch or batches onto disk via a tape-in (communications, remote entry, remote batch, or local tape unit), card reader, or OCR operation, and to associate each record within the batch with an input format.

This feature is used when the tape, cards, or communications being read into the system do not contain a standard job header, and if a standard job to control the formatting of data being read does not exist within the Standard Job Library.

Data formatting is the association of each record within a batch with an input format. A record as read from tape consists of a string of characters; an input format is necessary to divide the character string into fields and records. In this manner, each record may be displayed as tags and data in the same manner as any batch on disk.

The sequence used to assign formats to incoming tape records can be specified by the supervisor, or, if desired, the system will select record formats based on the first character of each record (conditional linkage). Once the batch is on disk, records within the batch can be corrected; new records can be added; the batch can be examined or reformatted, and all other system functions may be used to control and manage the data.

To execute the Read Batch feature, select the input device (tape unit, communications, remote entry, remote batch or card reader); enter the batch name and the code set name, if other than the default code set is to be used in the operation; and answer the conditional linkage question (refer to Read Standard Job). Once this information is entered, the system requests entry of input format names, the *links to* information, and the names of the Record and Batch End Edits to be applied to the data. Once this information is entered and the REL Key is depressed, the system executes the input operation. At the completion of the read operation, the system displays the number of records read into the system during the operation.

SELECTIVE TAPE INPUT*

When used in conjunction with the Append To Batch options, this feature makes it possible to read *selected* records from a tape onto disk. Its usefulness is based on the fact that a large, normally disk-resident file will have processing action on only a relatively small percentage of records in any one processing run.

In a disk system, the entire file is kept on disk and a processing run, e.g., adding new information to certain records, applies transactions against this master file. This method is faster than processing a file sequentially on magnetic tape, but the file can easily become very large and cumbersome.

With the Selective Tape Input feature, it is possible to store large files on magnetic tape rather than on disk and input to disk *only* those records requiring processing action.

*System 480 only.

To utilize this feature, two tape drives must be available. The master file may be kept on any tape unit available, except Tape Unit B. The master file must contain, as the first field of each record or group of records, a *key field* (or identifier field), such as a customer number; the records should be sorted in ascending sequence by this key field. A *transaction file* (also in ascending order, in EBCDIC), consisting of the key fields for all records to be input from the master file onto disk, is then created on tape unit B.

NOTE

Tape Unit B cannot be 7-channel and search key data can only be EBCDIC.

Figure 3-2 illustrates Selective Tape Input operation.

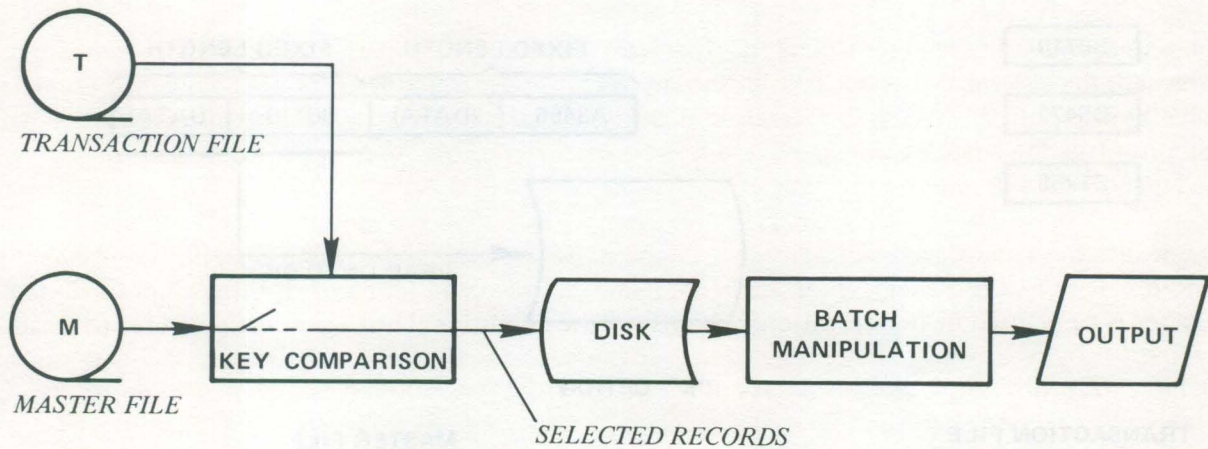

Figure 3-2. Selective Tape Input Operation

There are two options with respect to the Selective Tape Input Feature. During Tape Read In initiation, the Conditional (Y/N/P) question can be answered either with an "M" or with a "K".

If the Conditional (Y/N/P) question is answered with an "M", the following conditions apply for the tape-in operation. The master tape file must consist of fixed length records, either blocked or unblocked, containing only one program level, the first field of each record being the key field. The transaction tape contains unblocked search keys. The record length or records in the master file is entered in response to the Number of Records question. The system then compares the search keys in the transaction file with the first field of each record in the master file. If they match, that record, including the key field, is input from tape to disk. If they do not match, the system processes the next logical record.

If the Conditional (Y/N/P) question is answered with a "K", the following conditions apply for the tape-in operation. The master tape file can contain variable length blocks, which may contain more than one program level, the first field of each tape block being the key field. The transaction

tape contains unblocked search keys. The system compares search keys in the transaction file with the first field in each block in the master file. If they match, that block is then input according to the program select conditional tape-in option as if "P" had been answered in response to the Conditional question; i.e., data in the tape record, *excluding* the search key field, is input onto disk. If the search key and comparison field do not match, the next physical block is input and processed.

Once all desired records from the master file have been read into a batch on disk, further processing of this batch may be initiated using normal system processing functions.

For example:

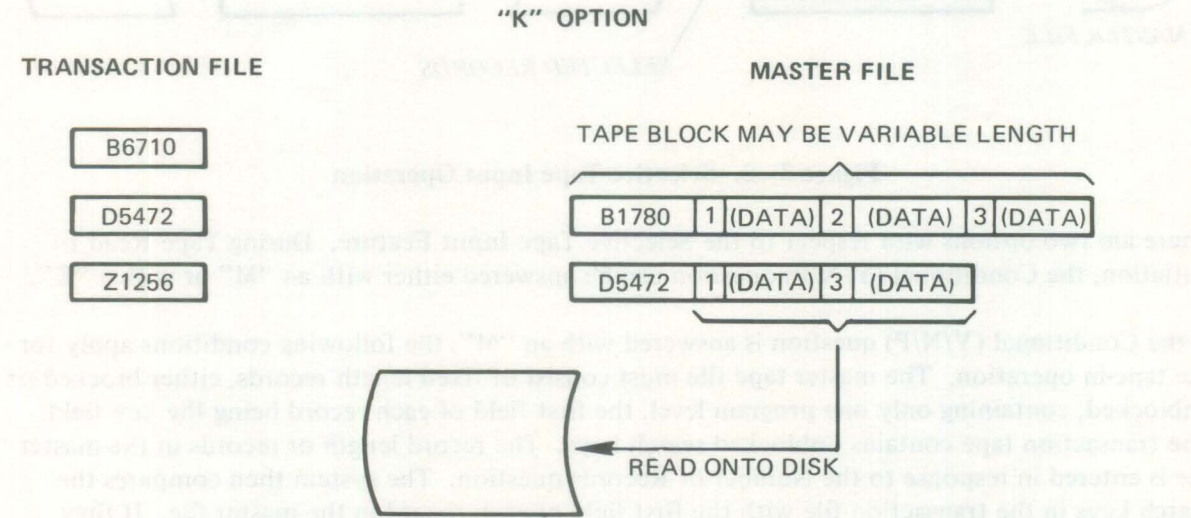
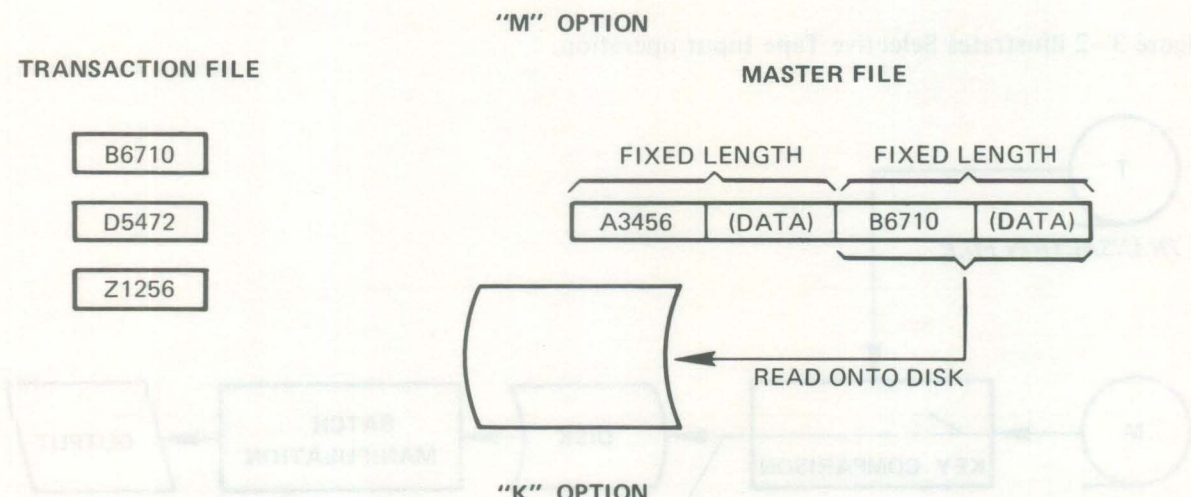

APPEND TO BATCH

The Append To Batch feature allows the supervisor to add records to a batch via a tape, communications, remote entry or card reader operation. Records are added to the batch via the input formats used initially to create the batch. To execute an Append To Batch operation, select the input device and enter the name of the batch to be appended. Additionally, the code set name, if other than the default code set is to be used in the operation, the number of records to be added to the batch, and the conditional linkage information must be entered. Once this information is entered and the REL Key depressed, the read operation is executed and the system displays the total number of records in the batch.

READ WITH STD JOB HEADER

This system feature enables the supervisor to read a tape containing a standard job name and associated data (batches) onto disk. This operation assumes that the tape to be read contains a header which is formatted as follows:

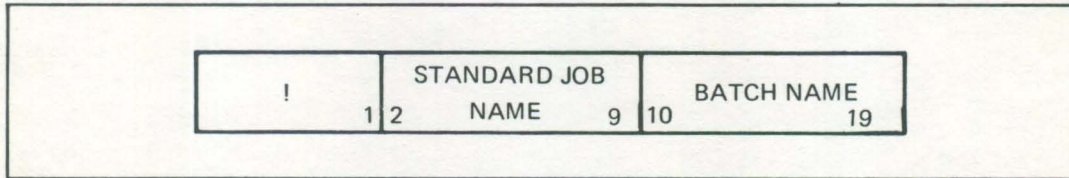

When the exclamation point (!) is encountered, a batch will be opened using the standard job name and batch names to follow. Data is then read under the program level specified by the first position of each data record.

To execute a Read With STD Job Header operation, select the input device (tape, communications, remote entry, or card reader) and enter the code set name, if other than the default code set is to be used in the operation. Once this information is entered, the system executes the read operation and displays the number of records read into the system during the operation.

NOTE

Depressing the AUTO Key prior to entry or release of the code set field allows the supervisor to read all batches on tape without interruption. If the AUTO Key is not depressed prior to code set entry, the read operation will stop at end-of-data for each batch, and manual depression of the REL Key will be required to read the next batch.

APPLY TO BATCH

The Apply to Batch feature allows the operator to add records to a batch or to delete records from a batch. The operator enters the name of the batch in the Batch Name field and the name of the record to be added or deleted in the Record Name field. The operator then enters the number of records to be added or deleted in the Number of Records field. The operator then presses the F10 key to apply the batch operation. The system then displays the total number of records in the batch.

READ WITH STJOB HEADER

The Read with STJOB header feature allows the operator to read a job containing a standard job and a standard data record. The operator enters the name of the job to be read in the Job Name field and the name of the data record to be read in the Data Record Name field. The operator then presses the F10 key to read the job and data record. The system then displays the job and data record information.

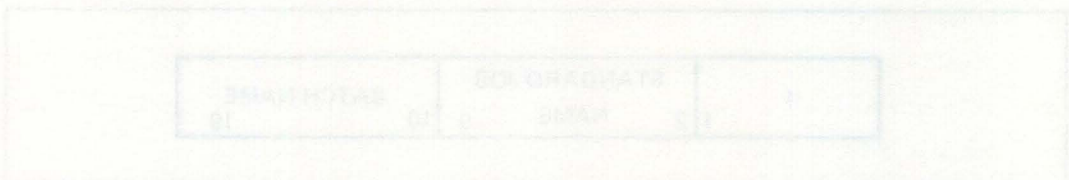

When the exclamation point (!) is entered in the Job Name field, the system will search for the job and data record information. Data is then read and displayed on the screen. The operator then presses the F10 key to read the job and data record. The system then displays the job and data record information.

To create a Read with STJOB header feature, the operator selects the input device (tape, console, or terminal) in the Read with STJOB header field. The operator then enters the name of the job to be read in the Job Name field and the name of the data record to be read in the Data Record Name field. The operator then presses the F10 key to read the job and data record. The system then displays the job and data record information.

NOTE

When the Read with STJOB header feature is used, the operator must enter the name of the job and data record in the Job Name and Data Record Name fields. The operator must also enter the number of records to be read in the Number of Records field. The operator must press the F10 key to read the job and data record. The system then displays the job and data record information.

SECTION 4 UTILITY OPERATIONS

The goal of the 80 Series system is data throughput; that is, the orderly entry and output of accurate data in a format that can be immediately processed by a business computer (mainframe). The primary output medium is magnetic tape. Data reformatting during output is controlled by Output Programs (formats); however, the convention used to handle files on tape is controlled by the supervisor via the Utility Operations List.

When the Utility Operations List is selected from the Supervisor HELP List, the following options are displayed:

- WRITE TAPE MARK
- WRITE TAPE MARK AND REWIND
- REWIND TAPE
- BACKSPACE ONE TAPE RECORD
- SEARCH FOR TAPE MARK
- SEARCH TAPE FOR SEQUENCE
- DEVICE FROM TAPE
- DEVICE FROM CARD READER
- COMMUNICATIONS UTILITIES

These options are logically divided into two categories as follows:

Manual tape handling options which the supervisor uses in unusual situations requiring almost manual tape manipulation. These options include:

- WRITE TAPE MARK
- WRITE TAPE MARK AND REWIND
- REWIND TAPE
- BACKSPACE ONE TAPE RECORD
- SEARCH FOR TAPE MARK
- SEARCH TAPE FOR SEQUENCE

Device utilities options which the supervisor uses to perform background utility functions. These options include:

- DEVICE FROM TAPE
- DEVICE FROM CARD READER
- COMMUNICATIONS UTILITIES

To fully understand the use of the tape handling options of the 80 Series system, it is necessary to understand the conventions used by the system in writing files on tape, and the conventions used by a business computer to process these files. These conventions are discussed under the following paragraphs.

MAGNETIC TAPE CONVENTIONS

Each reel of tape has a Beginning Of Tape (BOT) marker at the start of the recording area and an End of Tape (EOT) marker at the end of the recording area (Figure 4-1).

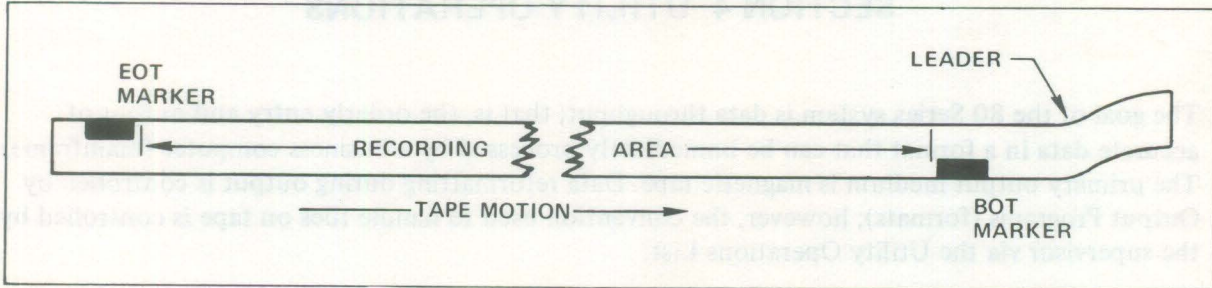

Figure 4-1. Magnetic Tape Conventions

These markers are small pieces of aluminum foil attached to the edge of the tape; the BOT marker can be seen when loading a tape.

Data is written to tape in a unit called a record. When the 80 Series system writes records to tape, each record is separated from the next by an inter-record gap (IRG) of approximately $\frac{3}{4}$ -inch as illustrated in Figure 4-2.

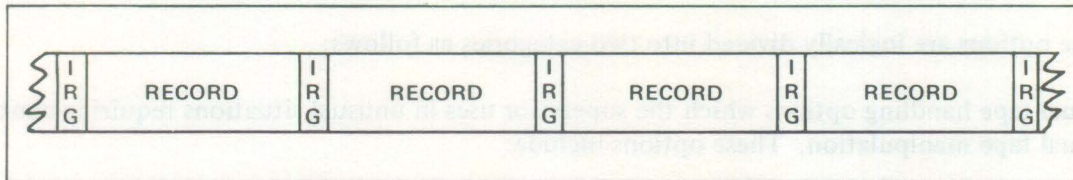

Figure 4-2. Physical Records on Magnetic Tape

To speed the processing of data by a business computer, a blocking factor is specified. When a blocking factor is specified, a number of data records are grouped together to form one *physical record*. This physical record is called a block on magnetic tape and is illustrated in Figure 4-3. When a business computer processes the tape blocks, it subdivides them back into smaller data records. The 80 Series system provides blocking of data records up to 4000 characters.

Each file on tape consists of one or more batches. Each batch contains a series of records created from the entered data and then, optionally, reformatted by Output Programs when written to magnetic tape.

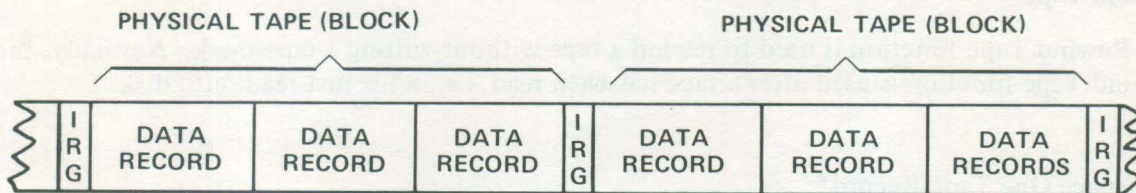

Figure 4-3. Data Record Grouped Three to the Block

If more than one file is contained on tape, the files are separated from each other by special tape records called "tape marks". During tape input (read operation), a tape mark indicates to the computer that the End Of File (EOF) in progress has been reached. Usually, two tape marks are used to indicate the end of data on that tape.

TAPE HANDLING OPTIONS

The following paragraphs provide a discussion of the tape handling options available to the supervisor when Utility Operations is selected from the Supervisor HELP List.

Write Tape Mark*

Write Tape Mark is used to indicate that a file written on tape is complete. Once a tape mark has been written at the end of a file, the supervisor can reposition the tape at that tape mark and add additional data to the end of the file via the Search For Tape Mark feature. The 80 Series system provides the supervisor with a method of adding data to the end of a tape file. This method is referred to as "appending" and is accomplished through the use of the Append Control function. This function is fully detailed in the "80" Series *Formatting Techniques Manual*.

Write Tape Mark and Rewind*

The Write Tape Mark and Rewind function is used to perform all the functions of Write Tape Mark in addition to rewinding the tape and resetting the system-generated record count.

NOTE

The Write Tape Mark and Write Tape Mark and Rewind functions require the use of a Write-Ring on the tape reel to allow tape marks to be written.

The 80 Series system allows the number of records affected by a tape operation to be displayed on the DATA/TERMINAL status line at the completion of the operation. The system continues to count records, adding the count of one file to that of the previous file until a reset instruction (reset count to zero) is encountered. The Write Tape Mark and Rewind and the Rewind Tape functions are the two commands that automatically reset the record count.

* These functions can also be performed automatically when coded in an Output Program.

Rewind Tape*

The Rewind Tape function is used to rewind a tape without writing a tape mark. Normally, the Rewind Tape function is used after a tape has been read, i.e., a file just read onto disk.

Backspace One Tape Record*

Backspace One Tape Record is selected to position the tape in a backward direction. Each time this function is selected, the tape is backspaced one tape record or block, if records are blocked, and the record/block counter is decremented by one and displayed on the DATA/TERMINAL status line. When backspacing over a tape mark, the count is not altered; tape marks are not included in system record counts. Backspace Tape is normally used in conjunction with Search For Tape Mark function.

Search For Tape Mark

The Search For Tape Mark function moves the tape forward and positions the read/write head at the end of the current file. Additionally, a running count of the number of records/blocks bypassed by this operation is displayed on the DATA/TERMINAL status line. Figure 4-4 illustrates the position of the tape after this feature is used.

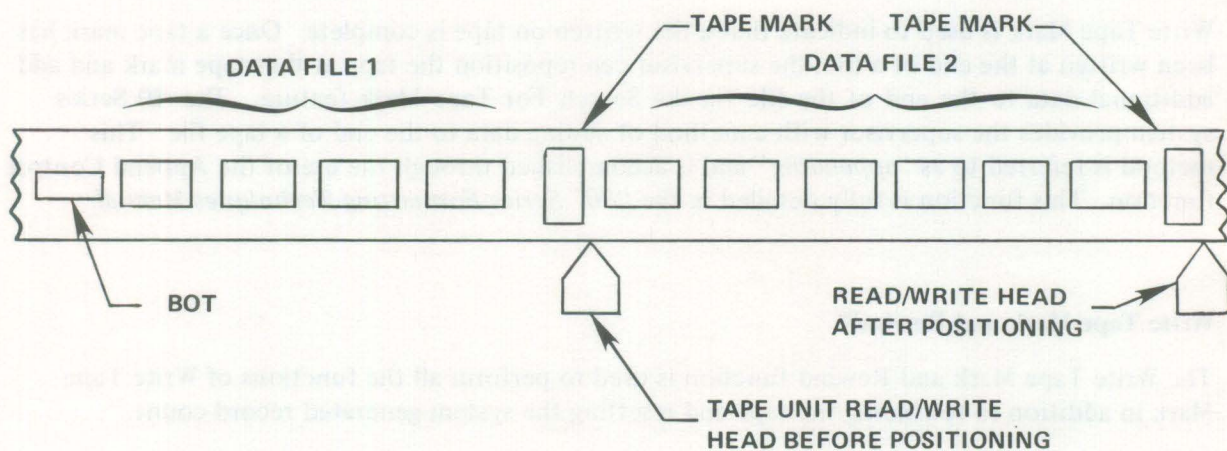

Figure 4-4. Search For Tape Mark Feature

The Search For Tape Mark function is used to position a multiple-file tape to a desired file for input to disk or to position an output tape, that has been rewound, for the purpose of adding another file, as follows:

* These functions can also be performed automatically when coded in an Output Program.

- Input – To read the second file of a multiple-file tape onto disk, execute the Search For Tape Mark function and follow the Read Batch procedure.
- Output – Two files, separated by a tape mark, have been written on a tape that was subsequently rewound. To add a third file, execute the Search For Tape Mark function twice to move the tape past the two files already on tape.

In addition, this function may be used to move the tape forward to the end of a current file. By controlling the positioning of a file in this manner, it is possible to read a portion of a large file onto disk, or it can also be used when reading libraries from tape onto disk. When all libraries are written individually on one tape, this operation is also used to locate the desired library for input to disk.

At times it may be desirable to interrupt or terminate a Search For Tape Mark operation before reaching a tape mark. This can be accomplished by depressing the PGM and HELP Keys. Once these keys are depressed, the system displays the number of records/blocks bypassed during the operation on the DATA/TERMINAL status line and presents the message "HIT REL TO PROCEED; OTHERWISE HIT HELP". Depressing the REL Key allows the search operation to continue; depressing HELP causes the operation to be terminated and the Supervisor HELP List to be displayed.

Search Tape For Sequence

The Search Tape For Sequence feature enables the supervisor to search a tape for a specific record number or character sequence and to display that data on the DATA/TERMINAL. Additionally, the supervisor has the option to repeat a tape search just completed by the system.

To execute a Search Tape For Sequence operation, select the tape unit (T1-4) and enter the code set required by the mainframe. Once this information is entered, the search method (record number, character sequence or repeat) is selected. If a record number search is selected, the system requests entry of the desired record number. When Search For Character Sequence is chosen, the system requests entry of the character sequence to be used as the search key. When the search statement is released, the search is executed by the system and the number of records/blocks bypassed by the search is displayed on the status line. When the specific record number or character sequence is located, the system displays the record or character sequence on the DATA/TERMINAL. If the specified item is not contained on the tape being searched, the system will display an end of data message. Record number searches are performed in both directions; character sequence searches are executed in a forward direction only.

DEVICE UTILITIES OPTIONS

Device utilities options have been included in the 80 Series system as aids to the supervisor in speeding data flow and management. These options allow the supervisor to perform the background operations illustrated on the following page.

- Off-line tape to print operations,
- Card reader to tape, communications or print operations,
- Tape to print or communications operations,
- Nixdorf to Nixdorf communications,
- Nixdorf to IBM 360/370 communications.

These operations are all performed as *background operations*; that is, the 80 Series system performs these operations *simultaneously with*, and, *without interference to*, data entry operations.

The following paragraphs provide a discussion of the device utilities options available to the supervisor when Utility Operations is selected from the Supervisor HELP List.

Device From Tape

The Device From Tape function allows the supervisor to print or display a tape record without a tape-to-disk operation. To execute a Device From Tape operation, select the output device (printer or CRT). When the printer is selected for output, the following four-page display is presented:

```

CODE SET OF TAPE _____
LINES PER PAGE ___
RECORD LENGTH ____   BLOCKED TAPE (Y/N) _
CONTROL CHARACTERS (Y/N) _
FILE MODE CHARACTER _
      TOP AFTER PRINT _   TOP BEFORE PRINT _
      NUMBER OF LINE FEEDS
      ONE AFTER PRINT _   ONE BEFORE PRINT _
      TWO AFTER PRINT _   TWO BEFORE PRINT _
      THREE AFTER PRINT _   THREE BEFORE PRINT _

```

FOUR AFTER PRINT _	FOUR BEFORE PRINT _
FIVE AFTER PRINT _	FIVE BEFORE PRINT _
SIX AFTER PRINT _	SIX BEFORE PRINT _
SEVEN AFTER PRINT _	SEVEN BEFORE PRINT _
EIGHT AFTER PRINT _	EIGHT BEFORE PRINT _
NINE AFTER PRINT _	NINE BEFORE PRINT _
TEN AFTER PRINT _	TEN BEFORE PRINT _
ELEVN AFTER PRINT _	ELEVN BEFORE PRINT _
TWELV AFTER PRINT _	TWELV BEFORE PRINT _
THR TN AFTER PRINT _	THR TN BEFORE PRINT _

FORTN AFTER PRINT _	FORTN BEFORE PRINT _
FIFTN AFTER PRINT _	FIFTN BEFORE PRINT _

SKIP TO CHANNEL

CHANNEL	AFTER PRINT	BEFORE PRINT	LINE
1	-	-	---
2	-	-	---
3	-	-	---
4	-	-	---
5	-	-	---
6	-	-	---

7	-	-	---
8	-	-	---
9	-	-	---
10	-	-	---
11	-	-	---
12	-	-	---

- Code Set of Tape – Enter the name of the code set that was used to output the tape, if other than the standard (default) code set being used by the system. If the tape code set is identical to the standard 80 Series system code set, field release through this field.
- Lines Per Page – This field is used to enter the maximum number of lines to be printed per page. When a number is entered in this field, the printer will execute a Top Of Form either when a Top Of Form control character is encountered or, if not encountered, when the specified maximum number of lines has been printed.
 - Line Feed Commands – If the Lines Per Page field is field released and line feed commands are utilized, the printer will continue to print lines of data until a Top Of Form character is encountered.
 - Channel Commands – When Skip To Channel commands are utilized, the Lines Per Page field becomes a mandatory entry field. If the Lines Per Page field is field released and Skip To Channel commands are utilized, the printer will continue to print lines of data until a Top Of Form character is encountered or 60 lines of data have been printed (60 lines being the default case, if this field is field released).
- Record Length – The Record Length field is used to indicate the number of characters in print-line record. The specified record length cannot exceed 134 characters (132 data characters and two control characters). If tape records are fixed length, enter the appropriate number of characters. If records are variable length, enter the number of characters in the largest record or field release through the record length field (default length equals 132 characters).
- Blocked Tape (Y/N) – To specify unblocked records, code an N to the BLOCKED TAPE (Y/N) question. Records *can* be blocked provided the block size does not exceed the system tape buffer. Specify Y for blocked records.
- Control Characters (Y/N) – Enter a yes (Y) to alert the system to interpret the first character of each record as a control character corresponding to the control characters entered within this display. If a printing format is desired, a yes (Y) must be entered under “Control Characters”. If no printing format is desired, field release through this field and release the remaining questions by depressing the REL Key.

NOTE

Control characters may be specified as any keyboard character except a space.

- File Mode Character – A file mode character is a control character which, when entered on the display page, is compared to the last character of a print-line record; if these characters are identical, the record is printed in accordance with any initial control character command. If these characters do not match, the record is skipped and the next record is interrogated.

The ability to specify a File Mode character allows the creation of selective reports from a single data tape even though specific print-line records are dispersed on the tape. For example, all print-line records for a specific report would contain the same character in the last position of each print line; then, when the report is required, that

character is entered as the file mode character on the tape-to-print display. During the print run, the system checks the last character of each print-line record for a character corresponding to the specified file mode character. When a match is found, the print-line record is printed in accordance with any initial control character command.

- TOP (Top Of Form) After Print – Once a yes (Y) has been entered under Control Characters, a character can be entered for the TOP After Print portion of this display. The control character entered by the supervisor can be any keyboard character; however, the character must correspond to the first character of any record to be printed prior to a Top Of Form action by the printer. For example, if an (A) is entered as the TOP After Print control character, the system will search the first character position of each record for an (A). When an (A) is encountered, the system will alert the printer to execute a Top Of Form after printing the record. Each time an (A) is encountered in the first character position of any record, the printer will execute a Top Of Form after printing the record.
- TOP (Top Of Form) Before Print – Once a yes (Y) has been entered under Control Characters, a character can be entered for the TOP Before Print portion of this operation. The control character entered by the supervisor can be any keyboard character; however, the character must correspond to the first character of any record to be printed after a Top Of Form action by the printer.

For example, if a (W) is entered as the TOP Before Print control character, the system will search the first character position of each record for a (W). When a (W) is encountered, the system will alert the printer to execute a Top Of Form before printing.

- Line Feeds After Print (1 through 15) – The Line Feeds After Print portion of this display is used to control line feed; that is, this function is used to print a line of data (up to 132 characters) and skip up to 15 lines prior to printing the next line. This function is similar to the TOP function in that a control character which corresponds to the first character of a record must be entered for the desired format (One After Print; Two After Print; Three After Print, etc.).

For example, if a (/) is entered as the control character for “One After Print”, the system will check the first character position of each record for a (/). When a match is encountered, the system will alert the printer to print the record and skip one (1) line prior to printing the next record.

NOTE

Each time a line is printed, a line feed to the next line occurs; therefore, the specification of “Line Feeds After/Before Print” will result in additional line feeds. The occurrence of a (/) in the example above would result in one blank line between print lines.

- Line Feeds Before Print (1 through 15) – These functions are characteristically identical to Line Feeds After Print except that the printing sequence is reversed; that is, the printer will execute the specified number of line feeds prior to printing a record.

NOTE

There is no restriction on the use of both the Line Feeds After Print and the Line Feeds Before Print portions of this display during a tape-to-print operation. If desired, a single control character may be used in both portions of this display. For example, if a (/) is specified for both "One Line Feed After Print" and "One Line Feed Before Print", the occurrence of a (/) would result in one blank line, a line of printed data, and another blank line prior to the printing of the next print-line record.

- Skip To Channel – The Skip To Channel portion of this display is used to command the printer to line feed until a specified line number is encountered; that is, this function causes the printer to line feed to a specified line number before or after printing a line of data, as follows:
 - Skip To Channel After Print (1 through 12) – The Skip To Channel After Print portion of this display is used to print a line of data and skip to a specified line number prior to printing the next line. This function requires that a control character which corresponds to the first character of a record be entered for the desired format, e.g., Skip To Channel 3 After Print, etc., and that a line number be specified, e.g., Line 31, etc.
 - Skip To Channel Before Print (1 through 12) – The Skip To Channel Before Print portion of this display is used to skip to a specified line number prior to printing a line of data. This function also requires that a control character which corresponds to the first character of a record be entered for the desired format, and that a line number be specified.

The addition of Skip To Channel portion of the tape-to-print feature allows the user to simulate the operation of a "Vertical Format Tape" without requiring that a special vertical format tape be punched. To properly use this feature, number each physical line on the print form and simulate the "channel punch" by specifying a channel number (enter an appropriate control character beside the desired channel command) and line number. During the print operation, the system interrogates the first position of each print-line record for a control character corresponding to a control character entered under this portion of the tape-to-print display. When a match is encountered, the printer executes the appropriate command.

Additionally, proper operation of this feature requires:

- The print form must be aligned to allow the print operation to commence from the *first* line of the print form.
- The "Lines Per Page" portion of the tape-to-print display must specify the maximum number of print lines per page.

Tape-To-Print Restrictions

- Control Characters – Any keyboard character *with the exception of a space* can be specified as a control character. The only criterion is that the first character of a print-line record must correspond to the control character entered on the Tape-To-Print display; otherwise it will be ignored and single-spaced.
- Control Character Duplication – A control character *may be* utilized in both the “before” and “after” columns of the following Tape-To-Print display sections:
 - Top Of Form (before and after print);
 - Line Feeds (before and after print);
 - Skip To Channel (before and after print).

However, a control character *cannot* be used twice in the “before” or twice in the “after” columns of the display sections. If the system encounters a duplicate control character within one column, the first command is executed and the second command is ignored.

- Control Character Interrogation – The 80 Series system interrogates the Tape-To-Print display in the following order:
 1. TOP Of Form Before Print.
 2. TOP Of Form After Print.
 3. Number of Line-Feeds Before Print, 1 Line Feed through 15 Line Feeds.
 4. Number of Line-Feeds After Print, 1 Line Feed through 15 Line Feeds.
 5. Skip To Channel Before Print, Channel 1 through Channel 12.
 6. Skip To Channel After Print, Channel 1 through Channel 12.
- Control Character Determination – Control characters entered for the purpose of print format are determined by the requirements of mainframe. If print-line records do not contain vertical-spacing control characters, the system will print data on a 132-character-per-line basis with single spacing between lines of printed data.

- TOP Of Form Function – There is no restriction on the use of the TOP function. If desirable, this function can be used in conjunction with the Line Feed and Skip To Channel portions of the Tape-To-Print feature.
- Line Feed Function – There is no restriction on the use of the Line Feed function. Up to 15 (3 with System 280) line feeds may be specified for both “before” and “after” print. Additionally, this function may be used in conjunction with the Skip To Channel portion of the Tape-To-Print feature; however, this method of formatting is more complex.
- Skip To Channel Function – Again, there is no restriction on the use of this function. The user may specify up to 12 channel skips, both “before” and “after” print.

Tape-To-Print Operation

Once the print format information is entered, the system requests the tape unit (T1-4) to be used in the operation. When the tape is selected, the print operation is executed.

The tape-to-print operation (Selection G DEVICE FROM TAPE) also handles the processing of unblocked records. An unblocked, tape-to-print operation can run concurrently with a communications operation.

NOTE

The Device From Tape feature does not manipulate records; it is designed as a “tape to print dump” operation. Data printed via this operation is written in the form of 134-character records (maximum). If data records are longer than 134 characters, the excess characters are truncated.

Device From Card Reader

The Device From Card Reader function allows the supervisor to write to tape, print or display data directly from a card reader without a card reader-to-disk operation.

To execute a Device From Card Reader function, select the output device (tape unit, printer or CRT). When a tape unit is selected as the output device, the system requests entry of the code set required by the mainframe. Once the code set statement is released, the card reader-to-tape operation is executed.

When the printer is selected as the output device, the card reader-to-printer operation is executed.

When the CRT is selected as the output device, the system displays data one record at a time. A depression of the REL Key is required to release the record being displayed. Once the REL Key is depressed, the system displays the next record.

NOTE

When a Device From Card Reader operation is completed, the system displays the number of records written or printed by this operation.

COMMUNICATIONS OVERVIEW

The Nixdorf system communications package supports both Nixdorf to Nixdorf communications and Nixdorf to non-Nixdorf communications. Using the telephone network, the Nixdorf system can transmit/receive to or from another Nixdorf system, and the Nixdorf system can transmit/receive to or from a non-Nixdorf system which conforms to IBM Binary Synchronous Communications (BSC) discipline. A Parameterized Communications Package permits the user to communicate with a wide variety of terminals without modification to mainframe or Nixdorf-supplied software. The following paragraphs highlight the communications options offered by Nixdorf.

Communications (Nixdorf to Nixdorf)

The word “communications” as used by Nixdorf refers to data transmission via the telephone network from one Nixdorf system to another. Communications allow data to be transmitted/received as individual batches, or batches can be combined and transmitted/received as files. Once the communicating Nixdorf system is prepared for transmission/reception, the systems can be left unattended. Additionally, operator activity (data entry and verification) at both systems can continue without interruption. Figure 4–5 illustrates Nixdorf to Nixdorf communications.

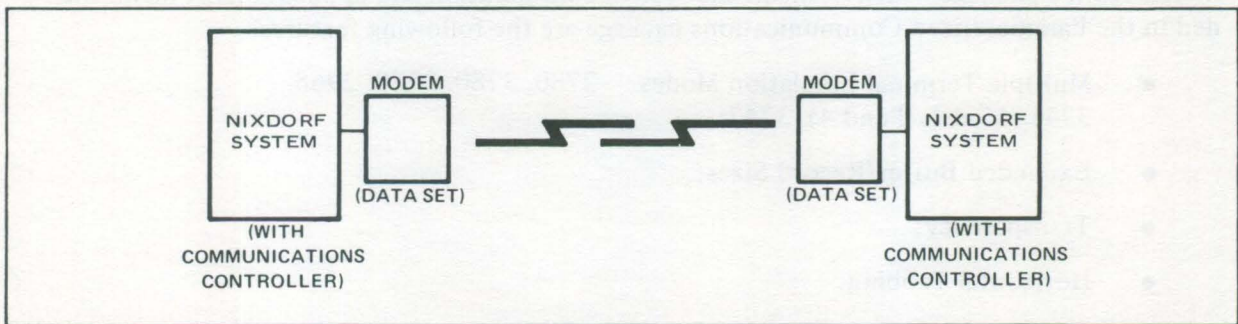

Figure 4–5. Nixdorf to Nixdorf Communications

Remote Entry (Nixdorf to non-Nixdorf)

The phrase "Remote Entry" as used by Nixdorf refers to data transmission via the telephone network between a Nixdorf system and a non-Nixdorf system. The one stipulation to this form of data transmission is that the non-Nixdorf system must emulate a 2780-type communications system.

Remote Entry allows data to be transmitted/received as individual batches, or batches can be combined and transmitted/received as files between a Nixdorf system and mainframes such as IBM's 360/370. Once a Nixdorf system is prepared for transmission or reception, it can be left unattended. Additionally, operator activity (data entry and verification) at the Nixdorf system can continue without interruption. Figure 4-6 illustrates Nixdorf to non-Nixdorf communications.

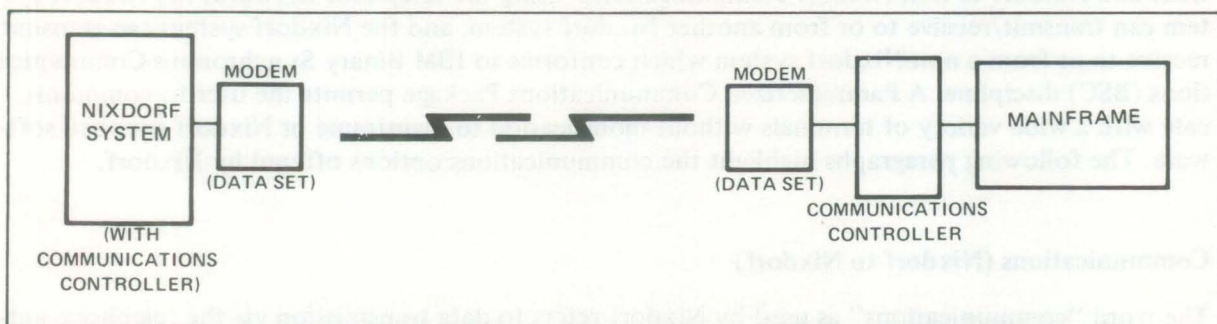

Figure 4-6. Nixdorf to Non-Nixdorf System Communications

Parameterized Communications

Parameterized Communications permits the user to emulate a wide variety of terminals without modification to the mainframe or Nixdorf-supplied software. The user can select those parameters from a package which best suit the system configuration and applications at hand. Included in the Parameterized Communications package are the following features:

- Multiple Terminal Emulation Modes 2780, 3780, 2770, 2968, 3741 (Models 2 and 4), 3747;
- Expanded Buffer/Record Sizes;
- Transparency;
- Horizontal Tabbing;
- Space Compression;
- Intermediate Record Separators;
- Polling and Addressing Sequence;
- Leading Graphics.

Communications Vocabulary

The following definitions are provided to further an understanding of communications:

- Binary Synchronous Communication (BSC) – A communications discipline defining data transmission rules. All BSC data is transmitted as a serial stream of binary digits (consisting of one and zero bits), with both receiving and transmitting stations acting in step-through recognition of a specific bit pattern (sync pattern) at the beginning of each data block.
- Data Access Arrangement (DAA) – When the user wishes to use independent modems and auxiliary equipment, the user may be required to lease a Data Access Arrangement. The modem manufacturer will specify what DAA is necessary.

The purposes and functions of a Data Access Arrangement are to:

- Provide a transmission path for user-provided data modems to the telecommunications network.
- Protect telephone personnel and equipment from hazardous voltages that may be generated by user-provided equipment.
- Provide protection of the user's equipment from the metallic line surges that may be present on the telephone network, and to limit data modem signal power to a specified value and to prevent interference with other telephone services.
- Provide network control signalling functions, including ring detection and on-hook signals.

In addition to the data or voice signals, telephone channels also carry special control signals transmitted within the voice band that provide dialing signals, special trunk activation and search signals, and accounting signals that activate billing equipment. It is possible for data signals, if not properly limited, to accidentally set such devices off. One of the functions of the DAA is to reduce the chance of this happening by limiting the user's signalling power.

- Data Record – The logical (user-oriented) unit of transmission. This is pure data, devoid of control information. This record is passed to the communications system which incorporates the necessary BSC data block requirements prior to transmission over the switched network. The following are examples of data records:
 - *One* punched card,
 - *One* print line,
 - *One* physical tape block,
 - *One* record as defined by an output statement.

- Data Set – Refer to Modems.
- Data Terminal – A device capable of originating data and error control signals for a transmission device and/or accepting data and error control signals from a transmission device. The 80 Series Central Control Group (not a specific terminal) is always defined as the data terminal.
- Data Transmission Block – The physical unit of transmission in any data communications link to include the framing, discipline and error control characters. Generation of the data block is a function of the hardware/operating-system interface, i.e., data block transmission is handled internally.

NOTE

Data Block Transmission should not be confused with a tape block which is defined as a data record (previously discussed).

- Leased Line Conditioning – Conditioning is simply a guarantee of the line quality along a leased line and is contracted for when a leased line is obtained. The grade of service (conditioning) contracted for may be C1, C2, or C4, and is solely dependent on the modem selected by the 80 Series user for data transmission.
- Leased Line (Private Line Service) – A leased line provides service only between two or more designated points. However, line quality is consistently maintained between locations in accordance with the contracted grade of service (conditioning).
- Modems (Data Sets) – A modem is the interface between the telephone line and the 80 Series system. Modems provide the modulation of data bits required for transmission across the telephone network, and the demodulation required at the receiving end. Modems can be obtained from the telephone company and/or from other manufacturers. It is also important to note that modems used *at each end* of a communications network must be compatible.

Switched Network – The switched network is the same telephone network used to place calls over a local exchange or the Direct Distance Dialing network. Use of the switched network provides no control over the quality of the circuit used by the automatic switching gear. It may be necessary to place the call several times to obtain a circuit of suitable quality.

- Transmission Lines – Transmission lines are classified as simplex, half duplex, and full duplex. In the United States and Canada, these terms have the following definitions:
 - Simplex – Line transmits in only one direction (not applicable to BSC).
 - Half Duplex – Line transmits in either direction, but only in one direction at a time.
 - Full Duplex – Line transmits in both directions simultaneously.

Communications Utilities

The Communications Utilities list is obtained by selecting (C) UTILITY OPERATIONS from the Supervisor HELP List, and then selecting (I) COMMUNICATIONS UTILITIES from the Utility Operations List. Once selected, the following screen displays are presented to the supervisor:

COMMUNICATIONS UTILITIES

A DATA SET DISCONNECT
B NIXDORF COMM RECEIVE
C REMOTE 2780 RECEIVE
D REMOTE BATCH RECEIVE
E NIXDORF COMM TRANSMIT
F REMOTE 2780 TRANSMIT
G REMOTE BATCH TRANSMIT

SELECTION

COMMUNICATIONS UTILITIES

A TAPE UNIT A
B TAPE UNIT B
C TAPE UNIT C
D TAPE UNIT D
E PRINTER (RECEIVE ONLY)
F CARD READER (TRANSMIT ONLY)

SELECTION

Use the Communications Utilities selections as follows:

Selection	Meaning
(A) DATA SET DISCONNECT	Physical communications break.
(B) Nixdorf COMM RECEIVE	Nixdorf to Nixdorf communications (reception).*
(C) REMOTE 2780 RECEIVE	IBM 2780 emulation (reception).*
(D) REMOTE BATCH RECEIVE	Operation determined by Communications Parameters (reception).*
(E) Nixdorf COMM TRANSMIT	Nixdorf to Nixdorf communications (transmission).*
(F) REMOTE 2780 TRANSMIT	IBM 2780 emulation (transmission).*
(G) REMOTE BATCH TRANSMIT	Operations determined by Communications Parameters (transmission).
(A-D) TAPE UNIT <i>n</i>	Tape unit for transmission/reception.
(E) PRINTER (RECEIVE ONLY)	Printer to be used for reception.
(F) CARD READER (TRANSMIT ONLY)	Card Reader to be used for transmission.

COMMUNICATIONS OPERATIONS

The communications package offered by Nixdorf is logically broken down into those options concerned with Nixdorf to Nixdorf data transmission, and those concerned with Nixdorf to non-Nixdorf (2780-type) data transmission. To further simplify an understanding of Tables 4-1 and 4-2, it is assumed that the communications link has been established between the two systems, i.e., the system supervisors are in telephone contact.

NOTE

Once the communications link has been established, the systems supervisors may place the systems on-line ("push the data button") at any time. There is no restriction on sequence or time allowed a communications operation.

* Does not apply to communications parameters.

TABLE 4-1. OPERATIONAL CONSIDERATIONS NIXDORF TO/FROM NIXDORF

OPTIONS USED FOR TRANSMISSION	
Tape to Communications	
<ol style="list-style-type: none">1. Place the tape reel containing data to be transmitted on the desired tape unit (T1-4).2. Place the tape unit on-line.3. Select (C) UTILITY OPERATIONS from the Supervisor HELP List.4. Select (I) COMMUNICATIONS UTILITIES from the Utility Operations List.5. Select (E) NIXDORF COMM TRANSMIT from the Communications Utilities List.6. Select the tape unit to be used (T1-4).7. Enter code set (field release if standard).8. "HIT REL TO PROCEED; OTHERWISE HIT HELP".9. Once the REL Key is depressed, the communications operation is initiated.10. Upon completion of the operation, the system displays the number of records transmitted.	
Card Reader to Communications	
<ol style="list-style-type: none">1. Place the cards containing data to be transmitted in the card reader.2. Place the card reader on-line.3. Select (C) UTILITY OPERATIONS from the Supervisor HELP List.4. Select (I) COMMUNICATIONS UTILITIES from the Utility Operations List.5. Select (E) NIXDORF COMM TRANSMIT from the Communications Utilities List.6. Select (F) CARD READER (TRANSMIT ONLY) from the Communications Utilities List.7. "HIT REL TO PROCEED; OTHERWISE HIT HELP".8. Once the REL Key is depressed, the communications operation is initiated.9. Upon completion of the operation, the system displays the number of records transmitted.	

TABLE 4-1. OPERATIONAL CONSIDERATIONS NIXDORF TO/FROM NIXDORF (Cont.)

OPTIONS USED FOR TRANSMISSION (Cont.)	
Disk to Communications	
<ol style="list-style-type: none"> 1. Select (B) BATCH I/O OPERATIONS from the Supervisor HELP List. 2. Select the desired write option from the Batch I/O Operations List: <ul style="list-style-type: none"> ● STANDARD JOB OUTPUT ● WRITE BATCH 3. Enter data requested by the system for the selected write operation, specifying CM (COMM UTILITIES) for output device. 4. Enter code set (field release if standard). 5. "HIT REL TO PROCEED; OTHERWISE HIT HELP". 6. When the REL Key is depressed, the communications operation is initiated. 7. Upon completion of the operation, the system displays the number of records transmitted. 	
OPTIONS USED FOR RECEPTION	
Tape from Communications	
<ol style="list-style-type: none"> 1. Place a scratch tape (reel must have a Write-Ring) on the tape unit (T1-4) to be used for operation. 2. Place the tape unit on-line. 3. Select (C) UTILITY OPERATIONS from the Supervisor HELP List. 4. Select (I) COMMUNICATIONS UTILITIES from the Utility Operations List. 5. Select (B) NIXDORF COMM RECEIVE from the Communications Utilities List. 6. Select the tape unit to be used (T1-4). 7. Enter code set (field release if standard). 8. "HIT REL TO PROCEED; OTHERWISE HIT HELP". 9. Once the REL Key is depressed, the communications operation is initiated. 10. Upon completion of the operation, the system writes one tape mark and displays the number of records received. 	

TABLE 4-1. OPERATIONAL CONSIDERATIONS NIXDORF TO/FROM NIXDORF (Cont.)

OPTIONS USED FOR RECEPTION (Cont.)
Printer from Communications
<ol style="list-style-type: none">1. Place the printer on-line.2. Select (C) UTILITY OPERATIONS from the Supervisor HELP List.3. Select (I) COMMUNICATIONS UTILITIES from the Utility Operations List.4. Select (B) Nixdorf COMM RECEIVE from the Communications Utilities List.5. Select (E) PRINTER (RECEIVE ONLY) from the Communications Utilities List.6. "HIT REL TO PROCEED; OTHERWISE HIT HELP".7. Once the REL Key is depressed, the communications operation is initiated.8. Upon completion, the system displays the number of records received.
Disk from Communications
<ol style="list-style-type: none">1. Select (B) BATCH I/O OPERATIONS from the Supervisor HELP List.2. Select the desired read option from the Batch I/O Operations List:<ul style="list-style-type: none">● READ STANDARD JOB● READ BATCH● APPEND TO BATCH● READ WITH STANDARD JOB HEADER3. Enter remaining data requested by the system for the selected read operation, specifying E (Communications) from the Communications Utilities List.4. "HIT REL TO PROCEED; OTHERWISE HIT HELP".5. When the REL Key is depressed, the communications operation is initiated.6. Upon completion, the system displays the number of records received.

TABLE 4-2. OPERATIONAL CONSIDERATIONS NIXDORF TO/FROM NON-NIXDORF

OPTIONS USED FOR TRANSMISSION TO A 2780 TYPE	
Tape to Remote Entry	
<ol style="list-style-type: none">1. Place the tape reel containing data to be transmitted on the desired tape unit (T1-4).2. Place the tape unit on-line.3. Select (C) UTILITY OPERATIONS from the Supervisor HELP List.4. Select (I) COMMUNICATIONS UTILITIES from the Utility Operations List.5. Select (F) REMOTE 2780 TRANSMIT from the Communications Utilities List.6. Select the tape unit to be used (T1-4).7. Enter code set (field release if standard).8. "HIT REL TO PROCEED; OTHERWISE HIT HELP".9. Once the REL Key is depressed, data transmission to the 2780-type device is initiated.10. Upon completion of the operation, the system displays the number of records transmitted.	
Card Reader to Remote Entry	
<ol style="list-style-type: none">1. Place the cards containing data to be transmitted in the card reader.2. Place the card reader on-line.3. Select (C) UTILITY OPERATIONS from the Supervisor HELP List.4. Select (I) COMMUNICATIONS UTILITIES from the Utility Operations List.5. Select (F) REMOTE 2780 TRANSMIT from the Communications Utilities List.6. Select (F) CARD READER (TRANSMIT ONLY) from the Communications Utilities List.7. "HIT REL TO PROCEED; OTHERWISE HIT HELP".8. Once the REL Key is depressed, data transmission to the 2780-type device is initiated.9. Upon completion of the operation, the system displays the number of records transmitted.	

TABLE 4-2. OPERATIONAL CONSIDERATIONS NIXDORF TO/FROM NON-NIXDORF (Cont)

OPTIONS USED FOR TRANSMISSION TO A 2780 TYPE (Cont.)	
Disk to Remote Entry	
<ol style="list-style-type: none"> 1. Select (B) BATCH I/O OPERATIONS from the Supervisor HELP List. 2. Select the desired write option from the Batch I/O Operations List: <ul style="list-style-type: none"> ● STANDARD JOB OUTPUT ● WRITE BATCH 3. Enter data requested by the system for the selected write operation, specifying REMOTE ENTRY (RE) as the output device. 4. "HIT REL TO PROCEED; OTHERWISE HIT HELP". 5. When the REL Key is depressed, data transfer to the 2780-type device is initiated. 6. Upon completion of the operation, the system displays the number of records transmitted. 	
OPTIONS USED FOR RECEPTION FROM 2780 TYPE REMOTE ENTRY	
Tape from Remote Entry	
<ol style="list-style-type: none"> 1. Place a scratch tape (tape reel must have a Write-Ring) on the tape unit (T1-4) to be used for the operation. 2. Place the tape unit on-line. 3. Select (C) UTILITY OPERATIONS from the Supervisor HELP List. 4. Select (I) COMMUNICATIONS UTILITIES from the Utility Operations List. 5. Select (C) REMOTE 2780 RECEIVE from the Communications Utilities List. 6. Select the tape unit to be used (T1-4). 7. Enter code set (field release if standard). 8. "HIT REL TO PROCEED; OTHERWISE HIT HELP". 9. Once the REL Key is depressed, data transfer from the 2780-type device is initiated. 10. Upon completion of the operation, the system writes one tape mark and displays the number of records received. 	

TABLE 4-2. OPERATIONAL CONSIDERATIONS NIXDORF TO/FROM NON-NIXDORF (Cont)

OPTIONS USED FOR RECEPTION FROM 2780 TYPE REMOTE ENTRY (Cont.)
Printer from Remote Entry
<ol style="list-style-type: none"> 1. Place the printer on-line. 2. Select (C) UTILITY OPERATIONS from the Supervisor HELP List. 3. Select (I) COMMUNICATIONS UTILITIES from the Utility Operations List. 4. Select (C) REMOTE 2780 RECEIVE from the Communications Utilities List. 5. Select (E) PRINTER (RECEIVE ONLY). 6. "HIT REL TO PROCEED; OTHERWISE HIT HELP". 7. Once the REL Key is depressed, data transfer from the 2780-type device is initiated. 8. Upon completion, the system displays the number of records received.
Disk from Remote Entry
<ol style="list-style-type: none"> 1. Select (B) BATCH I/O OPERATIONS from the Supervisor HELP List. 2. Select the desired read option from the Batch I/O Options List: <ul style="list-style-type: none"> ● READ STANDARD JOB ● READ BATCH ● APPEND TO BATCH ● READ WITH STANDARD JOB HEADER 3. Enter remaining data requested by the system for the selected read operation. Specify selection F from the Communications Utilities List. 4. Once the requested information is entered, "HIT REL TO PROCEED; OTHERWISE HIT HELP". 5. When the REL Key is depressed, data transfer from the 2780-type device is initiated. 6. Upon completion, the system displays the number of records received.

COMMUNICATIONS FEATURES

Nixdorf to Nixdorf Communications

- Record/Block Size – Communications supports the following physical record/block sizes:
 - Disk (input/output): 240 Characters
 - Tape (input/output): 240 Characters
 - Card Reader (input): 80 Characters
 - Printer (output): 132 Characters
 - Records Per Block: Unlimited
 - Block Size (max.): 800

NOTE

For transmission, records are packed in the communications software buffer until it is filled or until it contains the specified maximum number of records. On reception, records are returned to the user until the buffer is empty.

- Line Speeds – Supports data transmission speeds (line speeds) of up to 9600 bits per second.
- Data Compression – Supports data compression by allowing the replacement of all sequences of two or more zeroes or spaces with a two-character control sequence. This sequence indicates that compression has taken place, the compressed character and the number of characters in the compressed string, i.e., the number of characters (spaces or zeroes) that have been replaced by the control sequence. This is an internal feature which is transparent to the user and executed automatically during transmission.
- Extended Handshaking Discipline – Insures compatibility throughout the 80 Series family despite any performance differences. It also ensures that an *incompatible* selection has *not* been made by one end of the communications link.
- Extended Enquiry Retry – Automatically extends the normal number of retries from three to 20 upon receipt of a negative acknowledgment (NAK) which asks for a message to be repeated prior to timing out and sending an abort (EOT).

2780 – Emulation Communications

The 80 Series Remote 2780 feature allows the 80 Series system to become a 2780 Data Transmission Terminal emulator, as defined by IBM's *System Reference Library Publication GA27-3005* (file number 2780-09). Transmission to a 360/370 requires that these systems meet the following requirements:

- 2780 with Synchronous Data Adapter, Type II, EBCDIC code, EIA Data Set Interface and Auto-Call features; or
- 2703 with Synchronous Base IIA terminal control, EBCDIC code, Base Expansion (# 1440), Synchronous Attachment (# 7702), and Auto-Call (# 1340) features.

Nixdorf supports the following 2780 features:

- Record/Block Size – Nixdorf supports the record and block requirements of 2780 transmission, as follows:
 - 80 characters per record for transmission or up to 144 characters per record for reception.
 - Seven records per block.
 - Record content includes an end-of-data separator, CRC-16 block check, component selections, carriage control.
 - Block size of 400 bytes.
 - Extended Enquiry Retry – This extends the normal number of retries from three to 20 upon receipt of a NAK response to transmission before timing out and sending an abort (EOT). It also allows for indefinite retry if no response is received. This feature is turned off by the execution of a “PGM-HELP” instruction.
 - End to End Control Characters – Nixdorf supports these features in the Receive Mode *only*, as follows:
 - Horizontal Tab (HT) – This feature allows the transmitter to preset tab stops with a format record. Thus a data record containing tabs will cause the carriage to space over to the next tab stop.
 - End of Media (EM) – On a card-oriented system (non-Nixdorf), this feature causes the card reader/punch to stop processing the current card, eject it, and start processing the next. The system does not generate this character but will accept it. Upon receipt, the system pads out to position 80 and terminates the record. If the EM is received beyond position 80, the record is immediately terminated.
 - Component Selection Sequence (Escape Character and Control Character) ESC – Since the supervisor selects components via the keyboard, the system interprets only the following printer control information:
 - (A) – Print and go to Top Of Form.
 - (/) – Print and line feed once (single space).
 - (S) – Print and line feed twice (double space).
 - (T) – Print and line feed three times (triple space).
- Therefore, if receiving to printer, the printer control command is executed. If receiving to any other device, the ESC is dropped, but the control character is retained as the first character of the record.
- WACK (wait before transmit – positive acknowledgment) – Sent only by receiving CPU and causes enquiry (ENQ) to be transmitted from Nixdorf. After WACK is sent, the CPU can send another WACK, ACKO, AKC1, or EOT. WACK resets the ENQ retry counter and, therefore, does not time out.

The following 2780 features are *not* supported by the Nixdorf remote entry package:

- SOH Control Character – This is used for multi-drop lines. Even though a 2780 is not addressable” on such a line, it can coexist on a line with other types of terminals that are addressable.
- BEL Control Characters – This is used in terminal-to-terminal operations and causes a “gong” to sound which signals the operator of the distant terminal to enter “talk” mode.
- RVI – This is used in place of ACK0 or ACK1 by the receiving CPU. The 2780 treats the RVI as the correct positive response and sends the remaining record encoded with ETX; receives the proper ACK0 or ACK1 and sends an EOT. Since the 80 Series system is under the control of DATA/TERMINAL commands, this function is not appropriate. However, the system will accept this as a correct positive response, and continue normally without relinquishing the line.
- ENQ (Enquiry – middle of text) – The 2780 transmits an ENQ in the middle of text if “I/O Error” or “I/O Intervention Required” messages occur at the transmitting terminal. However, this does not apply to Nixdorf and the following occurs:
 - During Transmission – The Nixdorf system frames the proper end-of-block character and transmits the block. It will then send an EOT if directed to abort by the supervisor.
 - During Reception – The Nixdorf system accepts the ENQ as data, thereby forcing a “Block Check Error,” and responds with a NAK.
- VRC/LRC Checks – Not applicable to the Nixdorf system.

PARAMETERIZED COMMUNICATIONS

The Parameterized Communications package enables the user to emulate a variety of terminals by tailoring the Nixdorf communications software in several key areas:

- *Data Formatting* – The user can specify communications buffer size, record size, and maximum blocking.
- *Data Discipline* – The user can pack data through tabulation or compression, transmit non-EBCDIC codes, and select one of two types of record separators which indirectly selects the type of cyclic redundancy checking to be performed.
- *Bids and Retries* – The user can specify the number of bids to be made to try to establish a communications link, and the number of retries to be made to retransmit rejected text.
- *Identification* – For multi-point networks, the user can specify a polling sequence and an addressing sequence. On switched lines, the user can specify leading graphics, i.e., a terminal identification sequence.

The tailoring is effected through 12 communications parameters that are set to best fit the user’s communications configuration.

Specifying a Parameterized Communications Configuration

To specify a Parameterized Communications configuration, select (G) COMM PARAMETERS from the System Operations HELP List (Figure 4-7). The communications parameters are then displayed on the screen (Figure 4-8).

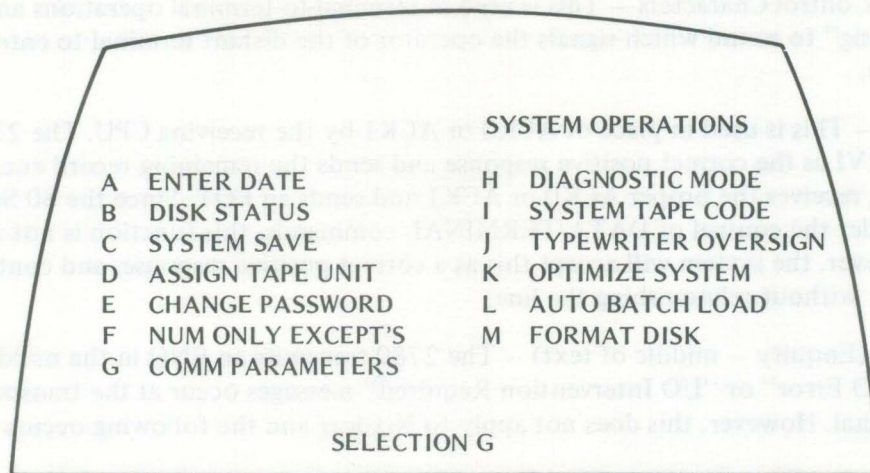

Figure 4-7. System Operations HELP List (with G selected)

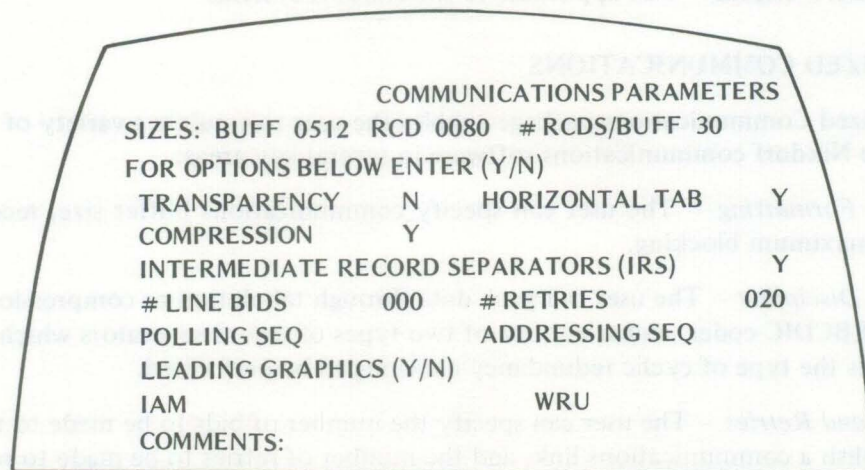

Figure 4-8. Communications Parameters

A value, as specified in the middle column of Table 4-3, can then be keyed for each parameter. The default shown in the right-hand column can *initially* be taken by hitting FIELD RELEASE. Once a value is entered, the parameter retains this value unless explicitly changed.

NOTE

When a Parameterized Communications configuration is not specified, a default configuration, consisting of the values shown in the right-hand column of Table 4-3, becomes effective.

TABLE 4-3. COMMUNICATIONS PARAMETERS

System Prompt	User Response	Default
BUFF	10 - 1024	512
RCD	1 - 1024	80
# RCDS/BUFF	0 ¹ - 99	30
TRANSPARENCY ²	Y/N	N ⁶
HORIZONTAL TAB ³	Y/N	N
COMPRESSION ³	Y/N	N
INTERMEDIATE RECORD SEPARATORS ²	Y/N	Y
# LINE BIDS	0 ⁴ - 999	0 ³
# RETRIES	3 - 999	20
POLLING SEQUENCE ⁵	Up to 3 alphameric characters	Blanks
ADDRESSING SEQUENCE ⁵	Up to 3 alphameric characters	Blanks
LEADING GRAPHICS ⁵	Y/N	N
IAM	Up to 15 alphameric characters	Blanks
WRU	Up to 15 alphameric characters	Blanks
COMMENTS	Up to 30 alphameric characters	Blanks

NOTES:

¹ Zero means the maximum that will fit in the communications buffer.

² INTERMEDIATE RECORD SEPARATORS and TRANSPARENCY are mutually exclusive of each other.

³ Compression and Horizontal Tab cannot be specified if RCD is set larger than 240.

⁴ Zero means unlimited bids.

⁵ POLLING SEQ and ADDRESSING SEQ are mutually exclusive of LEADING GRAPHICS.

⁶ Output <HEX nn> is allowed if Horizontal Tab is specified as Y.

A user needing more than one communications configuration should determine the parameter set for each configuration, and code each set of parameters as a Command Sequence. To set up a certain configuration, then, the user need only execute the proper Command Sequence. Proper use of the Command Sequence Processor insures accuracy in procedure execution and permits unattended operation when communicating.

When using the Command Sequence Processor for communicating according to Parameter Settings, the parameters should be set at the beginning of each step (Transmit or Receive) to insure accurate settings for the function to be performed. Always set *all* parameters; never assume any values will be preset as expected.

The following paragraphs discuss the communications parameters in more detail, and specify the operational changes made to permit use of Parameterized Communications. Figures 4-9, 4-10, and 4-11 illustrate the communications parameters for typical configurations.

```

COMMUNICATIONS PARAMETERS
SIZES: BUFF 0400 RCD 0080 # RCDS/BUFF 5
FOR OPTIONS BELOW ENTER (Y/N)
TRANSPARENCY      N  HORIZONTAL TAB  Y
COMPRESSION        N
INTERMEDIATE RECORD SEPARATORS (IRS)  N
# LINE BIDS        000  # RETRIES      020
POLLING SEQ                ADDRESSING SEQ
LEADING GRAPHICS (Y/N)
IAM                        WRU
COMMENT: IBM 2780 EMULATION
  
```

Figure 4-9. Example of Communications Parameters for Configuration Emulating a 2780

```

COMMUNICATIONS PARAMETERS
SIZES: BUFF 0512 RCD 0080 # RCDS/BUFF 7
FOR OPTIONS BELOW ENTER (Y/N)
TRANSPARENCY      N  HORIZONTAL TAB  Y
COMPRESSION        Y
INTERMEDIATE RECORD SEPARATORS (IRS)  Y
# LINE BIDS        000  # RETRIES      020
POLLING SEQ                ADDRESSING SEQ
LEADING GRAPHICS (Y/N)
IAM                        WRU
COMMENT: IBM 3780 EMULATION
  
```

Figure 4-10. Example of Communications Parameters for Configuration Emulating a 3780

```

COMMUNICATIONS PARAMETERS
SIZES: BUFF 0128  RCD 0128  # RCDS/BUFF 01
FOR OPTIONS BELOW ENTER (Y/N)
TRANSPARENCY      N  HORIZONTAL TAB      N
COMPRESSION       N
INTERMEDIATE RECORD SEPARATORS (IRS)      Y
# LINE BIDS       000  # RETRIES           020
POLLING SEQ              ADDRESSING SEQ
LEADING GRAPHICS (Y/N)
IAM                      WRU
COMMENT: IBM 3741 EMULATION

```

Figure 4-11. Example of Communications Parameters for Configuration Emulating a 3741 on a Switched Line

Data Formatting (RCD, BUFF, #RCDS/BUFF)

RCD

The Record Size specifies the maximum size logical record that the communications package is to accept from the user program or specified device. When communicating with a non-Nixdorf system, the Nixdorf system is normally treated as a standard remote job entry terminal having a card reader-like device for input. Consequently, the maximum record size is generally 80 characters. If the record size is exceeded, the message "MAXIMUM RECORD SIZE EXCEEDED" is displayed and communications is terminated.

NOTE

If the record size exceeds 240, 01 is specified beside RCD/BUFF.

The "MAXIMUM RECORD SIZE EXCEEDED" message display results in termination only in Transmission Mode. This parameter is ignored when the Nixdorf system is receiving.

For communications with non-card-oriented systems, such as 2780, 3780, or 3741, and for Nixdorf to Nixdorf communications, the following record size limits apply:

- Disk (input/output) — 240 Characters
- Tape (input/output) — 1024 Characters
- Printer (output) — 132 Characters

Typical settings for emulation might be: 2780/3780 — 80, 3741 — 128.

BUFF

The buffer size specified controls the size of the transmission block in Transmit or Receive Mode. Records are provided by OUTPUT verbs in output programs or from physical devices (tape drive, card reader). Except for tape, each of these devices delivers records that are logically and physically the same size. The system assumes that tapes are formatted with records of the same logical and physical length (unblocked). The Nixdorf communications package provides no facility for deblocking tapes on receive.

The Buff Size parameter is usually set according to the characteristics of the device being emulated, i.e., 3780 – 512, 2780 – 400, 3741 – 128.

NOTE

It is advisable when receiving to set BUFF SIZE larger than the emulated device since Nixdorf stores all characters received whether data or control.

The user must ensure that the buffers of communicating systems are compatible.

#RCDS/BUFF

This specification controls the maximum number of records to be assembled into a transmission block. This setting also affects the size of the receiving internal buffer. Typical device settings are: 2780 – 5, 3780 – 7, 3741 – 1.

The maximum record size and buffer size supported is 1024 bytes of data characters. As the number of records per buffer exceeds 30, the receiving buffer is diminished by two bytes for each record. Therefore, if #RCDS/BUFF = 31, then the maximum buffer size = 1022; if #RCDS/BUFF = 99, then the maximum buffer size = 886.

For transmission, records are packed in the buffer until it is filled or until it contains the specified maximum number of records. On reception, records are returned to the user until the buffer is empty. Figure 4–12 illustrates this process:

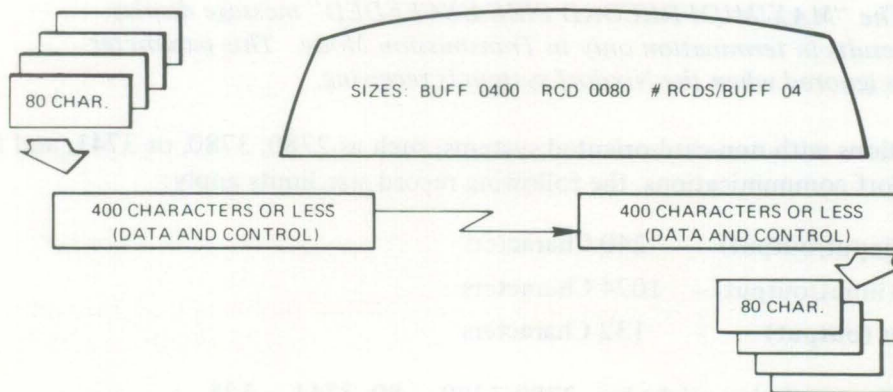

Figure 4–12. Example of Communications Data Formats

NOTE

In the previous example, the transmission buffer will handle four 80-character records. Although the buffer size is 400 characters, five records will not fit in the buffer because the buffer must also contain control characters.

Data Discipline

Data Discipline is concerned with the format of data as it is transmitted.

Transparency

Nixdorf systems transmit data according to EBCDIC standards. At times, however, the user may wish to communicate non-EBCDIC data, e.g., Nixdorf libraries or ASCII data. This is permitted if the parameter is coded as Y (the default is N). Thus, when transmitting, each record sent is coded as a transparent record; when receiving, each record is examined for the transparency code. Transparency allows for the transmission of data blocks which utilize the full eight bits of each byte. The use of transparency prevents the transmitting and receiving systems from interpreting data characters, which could adversely affect communications.

In using this feature, several points should be kept in mind:

- On a Nixdorf system, only tape or printer can be used to receive transparent (non-EBCDIC) data, because only EBCDIC data can be written to disk.
- If communicating with a non-Nixdorf system, the system component manual for the terminal type being emulated should be checked for the maximum number of transparent records allowed in the buffer. This number must be specified as #RCDS/BUFF.
- Because there is known overhead for each transparent record, the BUFF size must be set at $(2 \times \text{RCD}) + 6$ at a minimum.

Horizontal Tab

When specified as Y, this parameter permits a Nixdorf printer to emulate an IBM 2780 equipped with the Printer Horizontal Formatting Control feature. This feature allows the transmitter to set up tab stops (as on a typewriter) in a special format record. In data records that follow, the transmitter can indicate a tabbing operation and skip to the next tab stop, to avoid transmitting blanks. For detailed information on horizontal tabs, refer to IBM Publication GC30-2004, *IBM System/360 Operating System Basic Telecommunications Access Method*.

This parameter offers two additional benefits when specified as Y:

- Code set translation is bypassed both on transmission and reception, thus allowing for special printer control characters and format records to be transmitted from tape.
- HEX (non-EBCDIC) characters may be transmitted/received with *no regard for transparency*. This allows outputting escape sequences through an output program, thus negating the need for writing tabbed data to tape prior to transmission.

WARNING

Any HEX character may be transmitted or received if Horizontal Tab is specified as Y. Be certain that no illegal characters are being used.

If HORIZONTAL TAB is specified as N, all records and all characters are treated as normal data.

NOTE

The Horizontal Tab and Transparency features cannot be used simultaneously.

Compression

Space compression using the control characters Hex 1D and Hexnn (where nn is the number of blanks), is an effective means of packing data. When Y is coded for this parameter, the system is conditioned to strip 2 through 63 contiguous blanks from the transmitted data, replacing them with control characters for reconversion at the receiver. Use of this feature greatly enhances throughput in communication of data records which have a significant amount of blanked fields. See Figure 4-13 for an illustration of space compression.

Compression and Transparency are mutually exclusive since the control characters cannot be interpreted in Transparency Mode.

NOTE

With the Compression feature, the record size must be less than or equal to 240.

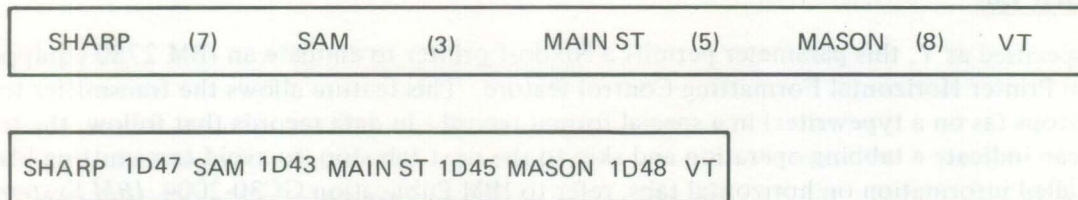

Figure 4-13. Example of Space Compression. The top illustration shows a normal record. The bottom illustration shows the record as it is transmitted using the Compression feature.

Intermediate Record Separators

This parameter governs the character used to separate records in the transmission block, and the method of calculation for Cyclic Redundancy Checking (CRC) of the data.

Older type terminals separate records with an Inter Unit Separator (IUS) followed by two CRC characters. Newer type terminals separate records with an Intermediate Record Separator (IRS) and no CRC characters, as illustrated in Figure 4–14.

NOTE

If the IRS option is chosen, # RCDS/BUFF and buffer size must be less than or equal to 1092.

NEW:

S		I		I		I	E	C	C	P
T	text	R	text	R	text	R	T	R	R	A
X		S		S		S	B	C	C	D

OLD:

S		I	C	C		I	C	C		E	C	C	P
T	text	U	R	R	text	U	R	R	text	T	R	R	A
X		S	C	C		S	C	C		B	C	C	D

Figure 4–14. Examples of Data Records Separated by IRS Characters (Top) and IUS Characters (Bottom)

Specify one of the following for INTERMEDIATE RECORD SEPARATORS (IRS):

- Y – for IRS (default).
- N – for IUS.

Emulation of 2780 requires N to be coded; 3780 emulation requires Y. Most newer BSC terminals will require Y.

NOTE

If the IRS option is chosen, TRANSPARENCY cannot be selected.

Bids and Retries

The #LINE BIDS and #RETRIES parameters determine handshaking and entry protocol, respectively.

Line Bids

When a station is ready to transmit data, a “line bid” enquiry sequence is sent to the receiving station. The receiving station must return a go-ahead signal (ACK0) before a communications link can be established. If the receiver fails to send the go-ahead signal, the transmitting station will keep sending bids for the number of times specified in #LINE BIDS. When the line bids are exhausted, communications mode is terminated, but the stations are not disconnected.

Retries

Once a communications link is established and text is being transmitted, the receiving station will reject text that cannot be read and request a retransmission. The receiving station will continue requesting a retransmission if the text remains unsatisfactory. The transmitting station will keep resending the same data for the number of times that station has specified #RETRIES (there must be at least three retries). When a station exhausts its retries, it aborts (terminates).

Identification

Standard identification techniques for multi-point systems and switched lines are provided.

Polling Sequence and Addressing Sequence

The Parameterized Communications package allows the system to be used as a slave station on a multi-point system. When this line-sharing technique is employed, the following must be specified to identify the user to the master station:

- POLLING SEQ – Used by master when polling slaves for input.
- ADDRESSING SEQ – Used by master when transmitting to slaves.

These parameters generally take the following form: *ttx*

The first *t* is the terminal type or identification character; the second *t* is a copy of the first *t* used for verification; and *x* is an optional component selection character, used on some terminals. For further information, consult the component description manual for the terminal type being emulated. The selection of these parameters must be coordinated with the operations personnel for the master station.

Leading Graphics

On switched lines, leading graphics are sometimes used as an identification sequence to establish communications with the mainframe. If, *and only if*, LEADING GRAPHICS is specified as Y, the IAM and WRU fields are made available to the user. The contents of the IAM field are sent by the transmitter during line contention. The contents of the WRU field are sent with the response to a line contention bid.

Consult the component description manual for the terminal type being emulated to ensure that this parameter is supported. Since this feature is not supported by all BSC terminals, the selection of the parameter should be coordinated with the operations personnel for the mainframe system.

NOTE

Only keyboard characters may be used as IAM/WRU. Nixdorf does not support hex configurations.

COMMUNICATIONS DYNAMIC TRACE – BISYNC ANALYZER

The Communications Dynamic Trace (BISYNC ANALYZER) provides a continuously updated display of binary synchronous line control instructions, as they are transmitted or received, on the upper lines of the keystation which is controlling communications. Observation of this sequence allows accurate diagnosis of communications malfunctions and the user may determine remedial action to be taken. The lower lines of the controlling keystation provide a running count of the control instructions transmitted or received, which can be used to observe the progress of an interchange.

Control characters traced are as follows:

- ENQ – Enquiry asks if ready to receive. It also requests retransmission of a response to a message block if the original response was garbled, or was not received as expected.
- ACK0 – Positive Acknowledgment of readiness for communications to begin, or Positive Acknowledgment used for an *even*-numbered transmission block.
- ACK1 – Positive Acknowledgment used for an *odd*-numbered transmission block.
- WACK – Positive Acknowledgment requesting a wait before response. Sent only by non-Nixdorf equipment.
- RVI – Positive Response sent only by non-Nixdorf equipment to request termination of the current transmission.
- NAK – Negative Acknowledgment used to indicate either that the receiving terminal is not ready, if responding to a line bid; or that a block was received in error, if responding to a text block.
- TXT – Text indicates that a transmission block was either sent or received.
- EOT – End Of Transmission is used to terminate a transmission and put both communicating stations in Control Mode.

A Trace message on the DATA/TERMINAL consists of one of the above control characters preceded by a T if the instruction is *transmitted*, or an R if the control instruction is *received*. The sequence of numbers following ACK0 or ACK1 begins with zero and alternates for each ACK displayed.

Trace Operation

The BISYNC ANALYZER will be displayed automatically on the screen of any terminal used to initiate communications unless it has been specifically disabled previously. It *cannot* be displayed on any other terminal. The display can be disabled or re-enabled by any terminal when communications is not in progress. During communications, the display can be disabled or re-enabled from any terminal *other* than that on which communications was initiated. Once enabled, the display will remain on the screen until it is disabled.

The Communications Dynamic Trace display is disabled or enabled from the Diagnostic Mode List. When the BISYNC ANALYZER option is selected, the system will display the message "BISYNC ANALYZER" and "HELP - RESET, REL - SET". Depressing the HELP Key will disable the display; depressing the REL Key will enable the feature.

Sequential Display

The sequential display shows characters which identify the communications line control (protocol) activity. Each communications transaction is displayed sequentially, with the display scrolling upwards line by line after the screen has been initially filled. A normal sequence seen on the *transmitting* system might be as follows:

TENQ RAK0 TTXT RAK1 TTXT RAK0

On the receiving unit, the same sequence would appear as follows:

RENQ TAK0 RTXT TAK1 RTXT TAK0

Upon attempting to call an 80 Series system on an Auto-Answer modem, if the receiving unit were not set up to receive, the following sequence would occur:

TENQ RNAK TENQ RNAK TENQ RNAK

The received negative acknowledgment (RNAK) indicates an established connection to a system not ready to receive. If an attempt to communicate is made, but no response is received, the following sequence would be displayed:

TENQ TENQ TENQ TENQ

The following instruction sequence is a receiving unit's Trace display for a block received in error and retransmitted correctly:

RTXT TNAK RTXT TAK1

Accumulative Display

The following accumulative display of the Communications Dynamic Trace shows the totals of all communication protocol transactions made:

	ENQ	TXT	EOT	ACK0	ACK1	NAK	RVI	WAK
T				3	2			
R	1	4	1					

Communications Dynamic Trace works during all communications. Even if the BISYNC ANALYZER is discontinued and reset, the counts are always correct, although some of the sequential display is skipped. The cumulative counts are also correct if the display is not set until after communications has begun, although the accumulator headings will not be displayed in such a case.

The top two lines of the Communications Utilities options page do not scroll with the sequential display so that the "NO. RECORDS -----" message will still appear at the center of the status line when applicable. Refer to Section 6 for a further discussion of the BISYNC ANALYZER.

NOTE

The screen display of the dynamic trace can tend to slow communication speed, especially during long transmission when the screen rolls up frequently. With high-speed modems, this amounts to a non-trivial percentage of time. If communication throughput is low, the Bisync Analyzer should be turned off.

ERROR RECOVERY PROCEDURES

The Nixdorf system handles all logical errors internally and aborts only when a physical problem is encountered and the maximum number of NAK's is received. The system *NEVER* hangs up the telephone link; rather the supervisor has the option to utilize the Data Set Disconnect feature of the Communications Utilities List.

Handshaking

The following procedures for both reception and transmission are applicable during handshaking:

- Reception — The receiver waits indefinitely. If an invalid message is received, the system tries again.
- Transmission — The following procedures are applicable:
 - If no reply within one second, the system tries again.
 - If a NAK is received, the system tries again.

- Invalid Reply (Invalid Acknowledge Received) – This message implies that someone is trying to transmit to a system that is *also* trying to transmit. After verbally contacting the other system, the communications operation may be attempted again.

Transmitting

The following procedures are applicable when transmitting:

- If the maximum number of NAK's is received, the system sends an EOT.
- If an EOT is received, the system displays the message "ABNORMAL END-OF-TRANSMISSION RECEIVED" and terminates normally.
- If PGM-HELP is depressed (manual abort) by the supervisor, the system turns off the Extended Enquiry Retry feature, and sends the last block with an ETB instead of an ETX and then issues an EOT, i.e., abnormal end-of-transmission. If three NAK's are received after the execution of a PGM-HELP command, the system sends an EOT without retransmitting the last block.

Receiving

The following procedures are applicable when receiving:

- If an EOT is received before an ETX has been received, the system displays the message "ABNORMAL END-OF-TRANSMISSION RECEIVED" and terminates normally.
- If PGM-HELP is depressed by the supervisor, the system stops receiving and sends an EOT in response to next block received.

NOTE

In all cases, the number of records received is the valid count. A difference in the number of records transmitted and received is due to the fact that during transmission, logical records are counted when passed to the communication system by the input device. However, these records may never be transmitted over the communications network. When receiving, records are counted when passed to a device from the communications system, i.e., records have been received.

The procedures outlined in Tables 4-1 and 4-2 are used for transmission and reception via Parameterized Communications by substituting Communications Utilities selections (G) for Transmit, and (D) for Receive, in order to have the communication session controlled by the parameters previously set. The communications parameters are employed by the system only when REMOTE BATCH has been selected from the Communications Utilities List, or when the Standard Job Output device has been coded as TC.

SECTION 5 LIBRARIES

The 80 Series system libraries are repositories for formats on disk. Library maintenance functions allow the supervisor to enter, store and manipulate the following formats associated with data entry/output and system management:

- STANDARD JOB
- INPUT FORMAT
- RECORD END EDIT
- BATCH END EDIT
- OUTPUT PROGRAM
- SORT PROGRAM
- COMMAND SEQUENCE
- CODE SET CONVERSION
- OPERATOR STATISTICS
- CHECK DIGITS

These formats are logically divided into two categories: those formats associated with data entry and output; and the formats associated with system management, as follows:

- | <u>DATA ENTRY/OUTPUT</u> | <u>SYSTEM MANAGEMENT</u> |
|-------------------------------------|--------------------------|
| ● STANDARD JOB DEFINITION | ● COMMAND SEQUENCE |
| ● INPUT FORMAT | ● CODE SET CONVERSION |
| ● EDITOR CODING FORMATS TO INCLUDE: | ● OPERATOR STATISTICS |
| – RECORD END EDITS | ● CHECK DIGITS. |
| – BATCH END EDITS | |
| – OUTPUT PROGRAMS | |
| – SORT PROGRAMS | |

In addition to the ability to enter, store and manipulate formats, the supervisor may read a library tape onto disk, or write the contents of associated formats from a set of libraries or all libraries to tape as well as write all libraries for a set of jobs to tape via the asterisk processor.

Formats are entered in associated libraries and stored on disk. Once on disk, these formats control the entry and output of associated applications.

The supervisor creates formats on an individual basis for each library. These formats are designed prior to data entry on Nixdorf supplied layout forms. The forms have been designed to correspond to the information requested by the system when format entry is initiated. Once the supervisor has created and entered the library formats, the supervisor can manipulate these formats via a comprehensive set of maintenance functions referred to as Library Options Lists.

The following paragraphs detail the various 80 Series system Libraries. Format coding is not addressed in this document. Rather, it is discussed in the "80" Series *Formatting Techniques Manual*.

STANDARD JOB LIBRARY

The Standard Job Library is used to enter, store and manipulate descriptions of frequently used jobs (standard jobs). Information required to describe the standard job is created on a layout sheet (Figure 5-1) and entered in the Standard Job Library by the supervisor.

Standard jobs, as created and entered in the Standard Job Library, contain the following information:

- STANDARD JOB NAME
- BATCH NAME PROTECTION
- INPUT FORMAT NAMES AND LINKAGE
- RECORD END EDIT
- BATCH END EDIT
- OUTPUT REQUIREMENTS

The operator's time required to start a job is reduced because this information is stored on disk under a standard job name. The entry operator has only to enter the standard job and batch names to obtain the input formats required for data entry. At output, the supervisor, using the standard job definition, enters the standard job and batch names to initiate output of desired information.

To assist the supervisor in the efficient entry and maintenance of standard job definitions, the system provides the following options:

- Display Standard Job Names – This option displays the names of specified formats in alphanumeric order (special characters, A through Z, and 0 through 9) and is used to check on the library status; that is, to see if a set of standard job names is present. This option works in conjunction with the Name Protection and Asterisk Processor features of the 80 Series system, e.g., to display all standard job names beginning with INV, enter INV*****.
- Create A Standard Job Definition – This option is used to enter a newly created standard job definition. When this option is selected, the system requests entry of the standard job name and checks to insure that no other standard job definition with the same name resides in the system. If a duplicate name is found, the system displays an error message; if no duplicate exists, a format conforming to the standard job definition form is displayed. The supervisor simply enters the information requested by the system to create a standard job definition.
- Change Standard Job Definition – This option is used to display the contents of a standard job and to modify an existing standard job definition. For the purpose of modification, the system uses the conventions of Examine Mode to display the format. All of the conventions for displaying and correcting data in Examine Mode apply to this option; that is, corrections can be made on a character, field or record basis.

NIXDORF 80 SERIES STANDARD JOB DEFINITION

STANDARD JOB NAME _____

BATCH NAME _____

DATE _____

PAGE _____ OF _____

INPUT FORMAT NAMES:			
#	NAME	LINKS TO	# NAME LINKS TO
1	-----	-	2 -----
3	-----	-	4 -----
5	-----	-	6 -----
7	-----	-	8 -----
9	-----	-	0 -----
RCD EDIT _____		BATCH EDIT _____	

1	OUTPUT DEVICE	---
2	RECORD SIZE	-----
3	BLOCK SIZE	-----
4	FIXED LENGTH (Y/N)?	-
5	BLOCKED RECORDS (Y/N)?	-
6	CHARACTER COUNT	-----
7	PADDING CHARACTER	---
8	CODE SET	-----
9	OUTPUT PROGRAM	-----

M-103 11/75

- 1 Output Device
Tn indicates a tape drive. n = 1 through 4.
PR = printer TC = terminal control
CM = communications RE = remote entry
- 2 Record Size
For fixed-length record, the record size in characters.
For variable-length records, the maximum record size in characters.
- 3 Block Size
For fixed-length records, the block size in characters.
For variable-length records, the maximum block size in characters.
- 4 Fixed Length?
Y = records are fixed length (default).
N = records are variable length. When N is specified, block size must be a multiple of record size.
- 5 Blocked Records?
Y = records are to be blocked.
N = records are not to be blocked (default).
- 6 Character Count
FIELD RELEASE indicates no character count.
If character count is desired at the beginning of each record, specify the format desired.
D = decimal count
B = binary count
S = spaces
D and B cannot be specified together. Imbedded spaces are not allowed. Up to 4 positions can be specified for the count.
- 7 Padding Character
Any keyboard character. Space is the default.
- 8 Code Set
Library name of the desired code set. FIELD RELEASE indicates standard system code set.
- 9 Output Program
Name of the output program to be used.

Figure 5-1. Standard Job Definition for Sample Program Package INVOICE

- Delete A Standard Job Definition – This option is used to delete a standard job definition from the library. If more than one standard job definition is to be deleted, the Asterisk Processor is used. If the Asterisk Processor is used, the system displays the names of all the standard job definitions which will be deleted by the operation. When the REL Key is depressed, the system deletes the formats from disk.
- Rename A Standard Job Definition – This option is used to change the name of an existing standard job definition. Prior to using this option, the supervisor should insure that operations such as Command Sequence will not be adversely affected by changing the name of the standard job definition.
- Copy Standard Job Definition – This option is used to copy the contents of an existing standard job definition to formulate a new standard job definition with a different standard job name. This feature is especially useful when an existing library routine differs only slightly from the one to be created. This feature saves time by allowing the supervisor to automatically copy an existing library routine and then make small modifications to the new routine via the “change” function. Note – the advantages of this feature are more apparent for long formats such as input formats.
- Write Print Image – This option is used to write the contents of a standard job definition on the 80 Series system tape, printer or DATA/TERMINAL screen. The Write Print Image option writes the standard job output exactly as it appeared when entered.
- Write To Tape – This option is selected to write the contents of selected Standard Job Library entries to tape via the asterisk convention; i.e., all standard job definitions within the Standard Job Library are written to tape.
- Read From Tape – This option is selected to read standard job definitions, contained on magnetic tape, to disk.

NOTE

If the tape is not positioned at the beginning of a Standard Job Library when this selection is made, the message “IMPROPER LIBRARY SELECTION” is displayed, and an error tone is sounded. When the RESET Key is depressed, the tape is rewound automatically.

INPUT FORMAT LIBRARY

The Input Format Library is used to enter, store and manipulate descriptions (formats) for all data to be keyed by an operator.

Input formats are created by assigning each format a unique name and specifying the checks for each field of the input record. The individual field definitions combine to form the input record format. Each field is assigned a number, length, and optional field tag as well as the appropriate editing and validity checks and verification required. The following checks and functions can be specified for input data (Figure 5-2):

- Field Use
- Verify
- Reverify
- Must Enter
- Must Complete
- Field Boundary Check
- Right Justify
- Fill Character
- Batch Balance:
 - A = add field content to an accumulator
 - S = subtract field content from an accumulator
- Accumulator Number
- Value Table Number
 - Invalid Entries
 - Table Order
- Range Check
- Auto Functions:
 - Duplication
 - Emit
 - Increment
 - Skip
- Check Digit:
 - system-generated
 - system-validated
- Multifield Check Digit
- Update
- Ascendency
- Tab Field
- Added Field
- Conditional Linkage

NOTE

A detailed description of the checks and functions listed above is contained in the Formatting Techniques Manual.

More than one input format may be required to describe all data records of a file and are created on an individual basis depending on the application (source document). Once an input format is created and entered in the Input Format Library, the supervisor can manipulate the format via the same library maintenance functions discussed under Standard Job Library.

RECORD END EDIT LIBRARY

The Record End Edit Library is used to enter, store and maintain record edit programs. Record End Edits supplement the immediate error detection capabilities contained within input formats by testing the logical interrelationship among fields *within the record*. All Editor language instructions with exception of the output instructions can be used in Record End Edits.

Record End Edits are executed as the operator releases each record and provide an excellent means of immediate error detection; that is, while the operator still has the source document at hand for easy correction. Additionally, they provide the capability to display a message explaining the nature of the detected error. If it is not desirable to display an operator message, the supervisor can elect to flag the error for later correction.

The Record End Edit Library is maintained by the supervisor using the same maintenance functions discussed under Standard Job Library. A detailed discussion of Record End Edits is contained in the "80" *Series Formatting Techniques Manual*.

BATCH END EDIT LIBRARY

The Batch End Edit Library is used to enter, store and maintain Batch End Edits. Batch End Edits provide the capability to test the interrelationships *among records* in a batch regardless of the input programs used for entry. Batch End Edits validate data entered by the operator, and may be executed automatically upon termination of the associated batch or at will by the supervisor (refer to Batch Edit feature, Batch Operations List, Section 2).

In addition to flagging errors and displaying messages when an error is detected, Batch End Edits are capable of building a Batch Log. The log is a file on disk which lists errors or any notable information found by the Batch End Edit. This file is assigned the same name as the batch being entered. When a data output statement is encountered during a Batch End Edit, the information specified in the output statement is placed in a Batch Log.

Batch End Edits executed automatically at the termination of a batch provide testing of data within the batch. When the supervisor requests a Batch Edit of several batches associated with a job (via the Asterisk Processor), the contents of associated batches are compared and tested.

Once the Batch End Edits are coded, the supervisor can maintain the Batch End Edit Library using the same library maintenance functions discussed under Standard Job Library. A detailed discussion of Batch End Edits is contained in the "80" *Series Formatting Techniques Manual*.

NOTE

Aside from the fact that Batch Edits are executed at will by the supervisor and not at batch termination, they are identical to Batch End Edits.

OUTPUT PROGRAM LIBRARY

The Output Program Library is used to enter, store and maintain Output Programs. Like Record End and Batch End Edits, Output Programs are written in the Editor language. Depending on application, Output Programs range from simple reformatting routines to powerful data generation and reformatting programs. The following is a list of the major Output Program uses.

- Reformating the order of fields within a record.
- Saving fields for use in subsequent output records (duplicating during output).
- Manipulating data on a character, subfield or field basis.
- Inserting zeroes, spaces or special characters.
- Inserting record and block counts as well as data.
- Formatting printed reports including headings and page numbers.
- Using arithmetic statements to generate new output data.
- Inserting new information based on the content of another field.
- Writing standard header and trailer labels.

Reformatting is the rearranging of data by character or field within and among records to produce an output record or records with data in a required order. It may be desirable to reformat records at output for one or all of the following reasons:

- Input format has been designed to follow the source document rather than the output format, thereby increasing data entry efficiency.
- Reformatting will eliminate the need for field duplicating, emitting, incrementing, and skipping during batch entry, thereby increasing the efficiency of the entry and verification processes and saving disk space.
- One source file on disk may be used to create output files for several applications.

Actions taken by an Output Program may be contingent upon any of the following factors:

- The number of the input format used to enter the record currently being reformatted.
- The content of a field within the record, or a field saved from a previous record.
- The presence of an error flag in the data.
- The occurrence of arithmetic overflow.

Many other tests can be included in the Output Program to insure that each record is reformatted in the appropriate manner.

It is important to note that Output Programs should be tested to insure that they produce the desired results. To fully test an Output Program, a Write Batch output operation that uses the output program should be executed by the supervisor. To insure that the output is correct, the supervisor can select either of the following output methods:

- If a line or serial printer is attached to the system, print the file to insure that the reformatted records are the proper length and contain the required information.
- Write data to tape and display the tape records to insure proper results.

Once the Output Programs are coded, the supervisor can maintain the Output Program Library using the library maintenance features discussed under Standard Job Library. Output Programs are discussed in detail in the *"80" Series Formatting Techniques Manual*.

SORT PROGRAM LIBRARY

The Sort Program Library is used to enter, store and maintain Sort Programs. The 80 Series system Sort capability allows records within one or more batches to be sorted to form a file of keys on the disk. Any field or sequence of fields in a record can be specified as keys. Any number of keys can be specified; the only restriction is that the total number of characters in a record specified as part of the key cannot exceed 200. Batches can be sorted in ascending or descending order. Ascending and descending key fields can be specified within a record.

Because the Sort feature is part of the Nixdorf Editor language, it has access to all language elements. Data can be validated as it is being sorted; errors can be flagged; or the sort can be terminated immediately, if the data does not meet the specified requirements. In addition to batches, other information contained in the system can be sorted, e.g., operator statistics. Once the Sort Programs are coded, the supervisor can maintain these programs using the library maintenance features discussed under Standard Job Library.

EDITOR CODING FORM

Record and Batch End Edits as well as Output and Sort Programs are created on Nixdorf Editor Coding Forms (Figure 5-3). This form has been designed to conform to the display presented by the system when a program is entered by the supervisor in an associated library; that is, the 10 lines displayed on the DATA/TERMINAL. As many forms as required can be used for the desired program.

To assist the supervisor in the entry of Record and Batch End Edits as well as Output and Sort Programs, the system displays compiler error codes. These codes are presented to the supervisor if a program containing errors is created or if the program is called from disk and improperly changed. Errors encountered in the program are displayed in the following format:

PAGE NO. – LINE NO. – ERROR CODE NO.

PAGE NO. refers to the page on which the error is present (where a page is equal to a display of 10 lines, 40 characters/line). LINE NO. refers to the number of the compiler error (1-54 and 71-84). Compiler errors and their definitions can be found in the *"80" Series Formatting Techniques Manual*.

INDIVIDUAL EDITOR LIBRARY INPUT

The Individual Editor Library Input feature allows individual Editor libraries to be output as data on the system and input into System Editor Libraries, thus allowing edit programs to be created as batches as well as allowing them to be read into more than one library.

NIXDORF 80 SERIES EDITOR CODING FORM

PROGRAM NAME _____ LIBRARY ASSIGNMENT _____

ORIGINATOR _____ DATE _____ PAGE _____ OF _____

PAGE _____

LINE #
1
2
3
4
5
6
7
8
9
10

NOTES

PAGE _____

LINE #
1
2
3
4
5
6
7
8
9
10

NOTES

M-102 9/76

Figure 5-3. Editor Coding Form

The ability to create edit programs as data batches results in the advantage of using Auto functions to create programs, as well as the capability to document programs. For example, if a program contains a long list of conditional statements with different conditions resulting in slightly different actions, it would be possible to code the field as a DUP field, turn Auto OFF, and dup the repeated characters, e.g.:

```
      DUP          DUP          DUP
  IF (2) = 'V2728', MOVE 'CORRESCOPE' TO DESC.
  IF (2) = 'A4596', MOVE 'SCUPPYDUCT' TO DESC.
  IF (2) = 'X1534', MOVE 'FRAMISTAN' TO DESC.
```

The capability to create edit programs as batches also aids in program documentation. For example, a batch may be created on disk consisting of two fields, with the first field being an edit program field (40 characters long) and the second field being a comments field. The edit program can be entered into the first field with comments inserted into the second field to assist in later program analysis and debugging. It would then be possible to output *only* Field 1 to tape and read this new edit program into the appropriate Editor Library. Just as easily, the program could then be read into *more than one* library if the requisite programs are quite similar and only minor modifications need to be made.

To utilize this feature, each library entry should appear on tape as follows:

1. The first data record and each name record must be from eight to ten characters long; however, only eight characters are used for the library name.
2. The maximum tape record size cannot exceed 200 characters, consisting of fields 40 characters in length and blocked by five.
3. It is suggested that the batch name be the format name and that each editor format field be 40 characters long with a comments field either following the data field or in another program level.

The output program for this batch could be as follows:

```
WHEN BATCH OUTPUT <LABEL> <BATCH> . OUTPUT (1).
RELEASE AT END OUTPUT <EOF> <RWND> .
```

COMMAND SEQUENCE PROCESSOR

Overall management of the system is augmented by the Command Sequence Processor which acts like a job control list to automate repetitive operator and supervisor functions.

The most unique aspect of the Command Sequence Processor is its ability to combine functions that are not already linked together by the system, e.g., linking a Batch Edit, a Sort, an Output To Tape, an Output To Print, and a Batch delete operation, so that all operations are linked together, and may be executed with one command. Common examples of operations which can be performed are given on the following page.

- Writing to tape using standard tape labels
- Standard job output
- Sorting and printing of operator statistics
- Inserting records at the end of a tape file
- Printing standard reports

The only normal system function which can not be performed via a Command Sequence Processor is the execution of a Command Sequence; however, the last thing the Command Sequence Processor may do is to call another Command Sequence. That is, Command Sequences may be executed in series but may not be nested.

Command Sequence Library

The Command Sequence Library provides a repository for unique Command Sequence names (up to eight characters) and their associated keystroke sequences (job control lists). Once a keystroke sequence is entered in the Command Sequence Library under a unique Command Sequence name, the supervisor may execute the Command Sequence by selecting the Command Sequence option from the Supervisor HELP List.

Command Sequence Coding

Command Sequence formats are coded on Nixdorf Command Sequence forms (Figure 5-4). The form is divided into two sections. The left-most section is used for coding the Command Sequence. The right-most section lists legal operation codes and characters.

When coding and entering formats, operational sequences are coded under OP-CODE. The characters to be keyed are coded and entered under CHR. The "NOTES" column has been included on the form to define the functions of each legal character.

To create a Command Sequence format, list those operations required as well as the desired operational sequence to be followed. Upon completion, manually perform the operations at the DATA/TERMINAL to insure that the desired result is obtained. The following steps are provided to insure an understanding of the coding requirements of a Command Sequence:

1. Make a list of the operations to be performed, e.g., Batch Edit on INV*****, Print Batch INV*****, etc.
2. Manually step through each of these operations at the DATA/TERMINAL Keystation *starting from the Supervisor HELP List*. As each key is depressed, write it down in sequence on scratch paper and label the start of each major functional section.
3. Convert the keystrokes on scratch paper to the required Command Sequence Code on the coding form. Note — only the special keystrokes require special coding on the form.

NOTE

The Command Sequence Processor does not make decisions; it merely executes the keystrokes in sequence, therefore, each keystroke must be recorded in the correct order.

NIXDORF 80 SERIES COMMAND SEQUENCE LAYOUT

COMMAND SEQUENCE NAME _____ ORIGINATOR _____ DATE _____ PAGE _____ OF _____

SCREEN LINE	OP-CODE	CHR	NOTES	OP CODE	CHARACTER
1				AU = depression of the AUTO key.	
				CL = backspace the cursor.	FIELD RELEASE indicates 1 character, F indicates 1 field, R indicates 1 record.
2				CO = depression of the COR key.	FIELD RELEASE, F, or R, following the conventions for CL, above.
				CR = forward space the cursor.	FIELD RELEASE, F, or R.
3				DL = depression of the delete key.	FIELD RELEASE or R.
				DP = depression of the DUP key.	
				FR = depression of FIELD RELEASE.	
4				HL = depression of the HELP key.	
				IN = depression of the I^S key.	ELD RELEASE or R.
				KY = stop to accept keystrokes from the keystation executing the command sequence.	
5				LR = depression of the LOC RET key.	
				NS = depression of the OVERSIGN key (negative oversign).	
6				PG = depression of the PGM key.	The number (0 - 9) of the program to be selected.
				PS = depression of OVERSIGN key with NUM shift (positive oversign).	
7				RC = depression of the RCD key.	D indicates that tags are to be turned off or on. F indicates flag error. R indicates repeat previous search. S indicates seek error flag. T indicates skip to next tab.
8				RL = depression of REL key.	
				RS = depression of RESET key.	
9				FIELD RELEASE = accept the keystroke in the Character column.	Any character that is legitimate for the function being performed.
				** = entry to be ignored.	

5-13

Figure 5-4. Command Sequence Layout Form

4. Once the entire sequence has been coded and checked, enter the format in the Command Sequence Library, and initiate the Command Sequence operation. If desired results are not obtained, correct the format.

The following suggestions should prove helpful in coding complicated Command Sequences:

- Start each Command Sequence with an ST op-code. This code puts the Command Sequence in a single-step mode; that is, the Command Sequence executes one keystroke each time the CURSOR RIGHT (→) Key is depressed. This code will allow the supervisor to view the individual steps of the Command Sequence on the DATA/TERMINAL to insure desired results. The start single-step mode (ST op-code) can be stopped by the SP op-code. This code stops the single step action of the Command Sequence, thus allowing the Command Sequence to automatically execute remaining keystrokes.
- Each major section of a Command Sequence should be coded on a single coding form so that control is brought back to the Supervisor HELP List; the remainder of the coding page should be filled with asterisks (*) (no operation is performed). Coding a Command Sequence in this manner will allow the supervisor to make modifications (in placement of the asterisks) to the Command Sequence in the most efficient manner.
- If major sections of a Command Sequence are long and involved, asterisks (*) may be coded at intervals to allow the supervisor to make modifications with the least amount of keying.

The following suggestions should prove useful when planning a Command Sequence operation that includes a "KY" instruction:

- Incorporate Extra REL Instructions – When a Command Sequence operation is designed to affect the output of data on disk, caution should be exercised when coding the "Valid/Invalid Matching Names" portions of the output statement.

If the number of REL instructions required to display the list of "Valid/Invalid Matching Names" prior to an output statement is not known, extra REL instructions must be coded. The extra REL instructions will accommodate the display of all "Valid/Invalid Matching Names" and allow the system to output the desired data. The use of extra REL instructions will not adversely affect the Command Sequence operation.

Additionally, this method can be used in conjunction with a "KY" command coded prior to the "Valid/Invalid Matching Names" portion of the output statement. The use of extra REL instructions will insure that the Command Sequence operation is synchronized through the output operation regardless of when PGM-REL is depressed, i.e., if the supervisor depresses PGM-REL prior to "Invalid Matching Names", the extra REL instructions will insure synchronous output operation.

- Incorporate Extra HELP Instructions – A positive method of insuring that the correct operation is executed after a "KY" instruction and the accompanying PGM-REL command is the coding of extra HELP instructions. These instructions can be coded to bring

the Command Sequence to the Operator HELP List. From this HELP List, the COMMAND SEQUENCE can be coded to desired conclusion. It is important to note that extra HELP instructions will not adversely affect the Command Sequence operation, because the Operator HELP List will be redisplayed until execution of the last HELP instruction.

NOTE

If a correction is made replacing the asterisks in either the op-code or the character column, the user must delete any remaining asterisks to insure that the correction is not ignored and the sequence disrupted.

Command Sequence Execution

To execute a Command Sequence, select PERFORM COMMAND SEQ. from the Supervisor HELP List and enter the Command Sequence name. Following depression of the REL Key, actual system execution of the desired Command Sequence is automatically executed starting with the Supervisor HELP List. This operation continues until end-of-file, accept keystroke (KY) command, manual abort (PGM-HELP), or non-programmed error message is encountered. The following is an explanation of the above terms:

- End-Of-File – End-Of-File is the execution of the last character of the Command Sequence. When the last character of the Command Sequence is executed, the DATA/SCOPE is left in the same state that would occur if all keystrokes had been executed from the keyboard.
- Accept Keystroke – When an Accept Keystroke (KY) command is encountered, the Command Sequence Processor is alerted to accept keystrokes from the keyboard until the PGM Key is held down and the REL Key is simultaneously depressed. When the PGM-REL Keys are depressed, the Command Sequence Processor resumes control and executes the remaining codes in the Command Sequence.

NOTE

Caution should be exercised when using the Accept Keystroke command. This command temporarily halts Command Sequence operation and allows the supervisor to control system operation via the keyboard. However, if at the completion of manual system operation, the supervisor desires to continue a Command Sequence operation, the DATA/TERMINAL must be placed at the operation displayed after the Accept Keystroke command. If this is not accomplished prior to the depression of the PGM/REL Keys, the conclusion of the Command Sequence is unpredictable.

- Manual Abort – Command Sequence execution can be prematurely terminated by holding down the PGM Key and depressing HELP (Manual Abort). Manual Abort will terminate a Command Sequence at any point in the operation except during input/output or edit program portions of the Command Sequence. If an input/output or edit function is in progress, only that function will be terminated. To terminate a Command Sequence under these circumstances, it is necessary to depress the PGM and HELP Keys a second time.

NOTE

To ensure that the Command Sequence operation is terminated, the supervisor can depress the PGM and HELP Keys several times or until the message "ILLEGAL KEYSTROKE" is displayed. At this point, the Command Sequence operation is terminated and the supervisor may initiate other operations.

- Error Messages – If an error message occurs during Command Sequence execution, e.g., "TAPE UNIT NOT READY", the Command Sequence Processor examines the next character in the Command Sequence File for a RESET code. If RESET is present, RESET (error) is accepted and Command Sequence execution proceeds automatically. If a RESET code is not the next character, the processor is placed in an Accept Keystroke mode (as if a KY command had been programmed) enabling the supervisor to take corrective action. When this condition occurs, the supervisor should depress RESET and either:
 - Continue Command Sequence execution (PGM-REL) after correcting the "in-error" situation, e.g., place the tape unit on-line for Command Sequence execution, or
 - Discontinue the operation via the PGM-HELP option (Manual Abort).

Command Sequence Library Maintenance

To assist the supervisor in maintaining the Command Sequence Library, the library maintenance functions, discussed under Standard Job Library, are available to the supervisor.

CODE SET CONVERSION LIBRARY

To insure that output from the system can be processed by a variety of different business computers, a Code Set Conversion Library has been included in the system. This library provides the ability to enter, store and maintain code sets required by the supervisor to meet mainframe processing requirements. Once a code set is entered in the library, the supervisor may select that code set when writing to or reading from tape, thus producing a tape in the desired code set for processing.

To enter a code set, select the Code Set Conversion feature from the Libraries List. When this feature is selected, the system displays the Library Options List discussed under Standard Job Library. Select CREATE from this list and enter the name of the code set to be entered. Once the name is released, the supervisor can enter the desired code set in the following manner:

- Answer the code set notation question by entering either (H) for *hexadecimal*, (O) for *octal*, (2) for *H2000*, or (6) for *H6000*. This is a mandatory entry field.
- Enter a “unique” two-character (low order six bits) designator for each keyboard character (64-character Code Set in addition to +0, -0, and Error Flag) in the following order:
 - A through Z
 - 0 through 9
 - Special characters
 - +0
 - -0
 - Error.
- Enter the collating sequence (1 to 8) for:
 - A through I
 - J through R
 - S through Z
 - 0 through 9
 - Special characters
 - Space characters
 - Plus zero
 - Minus zero.

If illegal characters are encountered by the system when the newly entered code set is released, the system displays the message “INVALID DATA ENTERED; DEFAULT CASE TAKEN.” The supervisor may either accept the default cases (error flags) or return to the code set and change the incorrect data.

When illegal characters are encountered by the system, error flags (#) are placed in the incorrect fields of the newly created code set. To avoid illegal characters, the following procedures should be adhered to:

- The code set notation (hexadecimal/octal) is a must complete field.
- If the NIXDORF system tape unit is 9-channel, specify (H), (2) or (6) for the code set notation question. If the tape unit is 7-channel, specify (O) for the code set question.

- The Nixdorf system allows the supervisor to enter duplicates within a code set. This feature is provided to allow maximum flexibility when creating a code set for a particular application; however, the supervisor should exercise caution when applying this feature and should test the code set in an input/output fashion to ensure desired results.

Table 5-1 illustrates the code set table as displayed by the system. Tape output codes for EBCDIC, ASCII, BCD, H-2000, ICL-7, and H-6000 are contained in Appendix B.

The standard code set for the 80 Series system is EBCDIC, however, the system will accept all industry standard code sets as well as special or supervisor-generated code sets. To assist in the maintenance of the Code Set Conversion Library, the library maintenance functions discussed under Standard Job Library are available to the supervisor.

NOTE

To simplify supervisor operations, the system allows the supervisor to specify one code set (by name) as the default code set for the system. This feature allows the supervisor to FIELD RELEASE from a code set question displayed by the system, if the code set to be used by the operation and the code set specified as default are the same. The operation of this feature is discussed in Section 6.

OPERATOR STATISTICS

Operator Statistics have been included in the Nixdorf system Libraries List to provide the supervisor with an accurate and detailed record of the performance of each operator. This option allows the supervisor to accumulate statistics for an operator(s) for any given period of time; that is, statistics can be accumulated on a daily or weekly basis.

When Operator Statistics is selected from the Libraries List, an "OP STATS LIBRARY" Options List is displayed. This list provides the supervisor with the following library maintenance options:

- Display – This option is used to display valid operator identifications, i.e., those identifications previously entered in the library using the Create option. To display all operator identifications, enter asterisks in all positions of the four character field and depress the REL Key.
- Create – This option is used to enter new operation identifications in the library. Once the supervisor creates a library of valid operation identifications, the system refers to this library when an operator logs-in (using the Operator Log-In function, Operator HELP List) at the DATA/TERMINAL. This reference is executed by the system to insure that the operator is using a correct four-character identification that is not in use at another terminal, and that operator statistics will be accumulated in the library.

TABLE 5-1. CODE SET CONVERSION TABLE*
(64 Character Code Set In Addition To +0, -0, And Error Flag)

HEXADECIMAL/OCTAL NOTATION (H/O/2/6)			
(A) --	(B) --	(C) --	(D) --
(E) --	(F) --	(G) --	(H) --
(I) --	(J) --	(K) --	(L) --
(M) --	(N) --	(O) --	(P) --
(Q) --	(R) --	(S) --	(T) --
(U) --	(V) --	(W) --	(X) --
(Y) --	(Z) --	(0) --	(1) --
(2) --	(3) --	(4) --	(5) --
(6) --	(7) --	(8) --	(9) --
(φ) --	(.) --	(<) --	(() --
(+) --	() --	(&) --	(!) --
(\$)	(*)	()	(;)
(¬) --	(-) --	(/) --	(≠) --
(,) --	(%) --	(_) --	(>) --
(?) --	(:) --	(#) --	(@) --
(') --	(=) --	(") --	(SP) --
(+0) --	(-0) --	(ERR) --	

COLLATING SEQUENCE (1 to 8)	
(A through I) _	(J through R) _
(S through Z) _	(0 through 9) _
(Spec. Char.) _	(Space Char.) _
(Plus Zero) _	(Minus Zero) _

*NOTE – +0, -0, and ERROR FLAGS are special cases which are treated differently from other characters as the following example for it illustrates:

- At Input – The supervisor specifies what input character is to be called +0. The system then converts that character to the EBCDIC character for +0.
- At Output – The system writes the +0 as the character specified.

Duplicates are supported by the system in the following manner: If the supervisor specifies HEX 61 for both A and C, the system will not indicate an error; rather, the system will accept the last character read into the system as in the input character. At output, both EBCDIC A and C will be written as 61.

When the Create option is selected, the system requests the first four-character operator identification. After this operator identification is entered, the system automatically displays another four-character field delimiter. When the desired number of operator identifications is entered, the REL Key is depressed. A second depression of the REL Key will cause the options list to be displayed, and operator identifications to be stored in the library.

Each operator identification must be unique. As many as 40 identifications can be entered on one display page. After operator entries have been created, an operator can log-in at any keystation, however, an operator cannot be logged-in at more than one keystation simultaneously.

- Initialize – Operator statistics can be accumulated for any desired period of time; that is, a new entry will be made for each new batch keyed or verified by an operator. The Initialize option allows the supervisor to set the summary statistics for one operator or a group of operators (via asterisk processor) back to zero and delete all batch statistics records. This option retains operator identifications. Following execution of the Initialize option, new statistics will be accumulated for work accomplished by the operator until the Initialize option is executed once more.
- Delete – This option is used to delete all summary and batch-oriented operator statistics as well as the four-character identification for one or more operators.

To execute the Delete option, select Delete from the library maintenance list and enter the operator identification. If information pertaining to more than one operator is to be affected, the Asterisk Processor is used. Once the identification(s) is entered, a depression of the REL Key will cause the system to display the four-character identifier(s) for the statistics to be deleted. Depressing REL will initiate the delete operation; depressing HELP will terminate the request without deleting any statistics.

NOTE

The Initialize option resets an operator's summary record to zero and deletes all batch statistics. The Delete option removes all statistics as well as the operator's identifier from the library.

- Display Statistics – This option is selected for one or more operators. Operator statistics are displayed by the system using the conventions of Examine Mode.

To display statistics for a particular operator, enter the four-character operator identifier. When the REL Key is depressed, the system displays summary statistics for that operator. When the REL Key is depressed a second time, the system displays statistics for the first batch entered or verified by that operator. Each time the REL Key is depressed, a record is displayed until the end of the file for that operator is reached.

NOTE

Summary statistics are an accumulation of the individual batch statistics for a particular operator. Figure 5-5 illustrates the format for summary statistics.

Batch statistics provide information pertaining to individual batches keyed by the operator. Figure 5-6 illustrates the format for batch statistics.

When the supervisor has completed a Display Statistics operation, the HELP Key is depressed. At this point, the supervisor may return to statistics to display information pertinent to another operator or terminate the operation.

- Sort – Sort Statistics is used to perform a sort on the statistics for a particular operator or operators (via Asterisk Processor). This option is used in conjunction with a Sort Program coded by the supervisor and stored in the Sort Program Library.

To execute the Sort option, enter the sort program name, the code set required for processing, the sort file name, and the operator(s) identification. When this statement is released, the system establishes a sorted file on disk. This sorted file is then held on disk until deleted by the supervisor. The supervisor can output the sorted file to tape or printer at will via the Write Batch option of the Batch I/O Operations List.

- Write Statistics – Each Operator Statistics batch can be written to tape, printer or communicated. To execute a Write Statistics operation, the supervisor must first establish an output program and a standard job within the associated system libraries. Figure 5-7 illustrates a typical Output Program for Operator Statistics.

Standard Job creation for this operation is unusual, in that the supervisor must enter only a standard job name and output requirements. Input formats and linkage are not entered. Therefore, after standard job name entry, the supervisor need only enter spaces for batch name protection and then depress the REL Key three times and enter the output requirements to include the associated Output Program name.

Two input formats are supplied by the system to structure Operator Statistics data. The first input format is used for summary statistics for each operator; the second is used for batch statistics. These formats have the same characteristics as supervisor-created record formats. Table 5-2 lists each field in the summary statistics input format as well as listing the associated field numbers and lengths. Table 5-3 lists similar information for the batch statistics input format.

NOTE

The times, displayed in ENTRY/UPDATE and VERIFY, for both summary and batch statistics, are rounded up; that is, if the actual time is x minutes and greater than 30 seconds the time is incremented to the next minute.

SUMMARY STATISTICS FOR					ENTRY/UPDATE	VERIFY
TIME:		00:00			00:00	
GROSS KEYS	0000000000000000				0000000000000000	
NET KEYS	0000000000000000				0000000000000000	
GROSS RATE	0000000000000000				0000000000000000	
NET RATE	0000000000000000				0000000000000000	
# CORS						00000000
# RECORDS			000000			000000

Figure 5-5. Summary Statistics Format

BATCH NAME					ENTRY/UPDATE	VERIFY
DATE:			00/00/00		00/00/00	
TIME:			00:00		00:00	
GROSS KEYS			00000000		00000000	
NET KEYS			00000000		00000000	
GROSS RATE			00000000		00000000	
NET RATE			00000000		00000000	
# CORS						000000
# RECORDS				000000		000000

Figure 5-6. Batch Statistics Format

TABLE 5-2. SUMMARY STATISTICS FORMAT (FIELD NUMBERS AND LENGTHS)

FIELD NO.	FIELD NAME	FIELD LENGTH
1	SUMMARY STATISTICS FOR	4
2	MONTH	2
3	DAY	2
4	YEAR	2
	ENTRY/UPDATE	
5	NUMBER OF HOURS	2
6	NUMBER OF MINUTES	2
9	GROSS KEYSTROKES	13
11	NET KEYSTROKES	13
13	GROSS RATE	13
15	NET RATE	13
18	NUMBER OF RECORDS	5
	VERIFY	
7	NUMBER OF HOURS	2
8	NUMBER OF MINUTES	2
10	GROSS KEYSTROKES	13
12	NET KEYSTROKES	13
14	GROSS RATE	13
16	NET RATE	13
17	NO. OF CORRECTIONS	8
19	NO. OF RECORDS	5

Individual batch statistics provide information pertaining to the total amount of time spent by a particular operator in a batch. This time is calculated in hours and minutes and is initialized when the operator selects Entry, Update or Verify Mode. The amount of time in the batch is calculated when the operator terminates the batch. If during the operation, the operator interrupts the batch, timing is stopped and is not continued until the operator resumes the batch. Times do not include the time to complete Batch End Edits, however, the time to complete Record End Edits is included.

**TABLE 5-3. INDIVIDUAL BATCH STATISTICS FORMAT
(FIELD NUMBERS AND LENGTHS)**

FIELD NO.	FIELD NAME	FIELD LENGTH
1	BATCH NAME ENTRY/UPDATE	10
2	MONTH	2
3	DAY	2
4	YEAR	2
8	NUMBER OF HOURS	2
9	NUMBER OF MINUTES	2
12	GROSS KEYSTROKES	7
14	NET KEYSTROKES	7
16	GROSS RATE	7
18	NET RATE	7
21	NUMBER OF RECORDS VERIFY	5
5	MONTH	2
6	DAY	2
7	YEAR	2
10	NUMBER OF HOURS	2
11	NUMBER OF MINUTES	2
13	GROSS KEYSTROKES	7
15	NET KEYSTROKES	7
17	GROSS RATE	7
19	NET RATE	7
20	NO. OF CORRECTIONS	7
22	NO. OF RECORDS	5

Once the prerequisites for a Write Statistics operation have been met, the supervisor need only select the option, and enter the standard job name and the operator identification to be affected by the operation. If more than one operator identification is to be affected by the operation, the Asterisk Processor is used. When this statement is released, the system writes the statistics to the device specified by the standard job. Figure 5-8 illustrates a printout of summary and batch statistics.

OPERATOR STATISTICS FOR DEB1 10/20/76

	ENTRY/UPDATE	VERIFY
TIME:	0: 1	00:00
GROSS KEYS	164	000000000000
NET KEYS	137	000000000000
GROSS RATE	9840	000000000000
NET RATE	8220	000000000000
# CORS		00000000
# RECORDS	3	00000
BATCH NAME DEB1		
	ENTRY/UPDATE	VERIFY
DATE:	10/20/76	00/00/00
TIME:	0: 1	00:00
GROSS KEYS	164	00000000
NET KEYS	137	00000000
GROSS RATE	9840	00000000
NET RATE	8220	00000000
# CORS		00000
# RECORDS	3	00000

Figure 5-8. Summary and Batch Statistics Printout

CHECK DIGIT LIBRARY

Check digit routines insure that a field containing vital data is correctly keyed. A check digit is the last digit of a numeric or alphanumeric data field and is arithmetically related to the rest of the field.

If the system is to validate a check digit within a data field or multiple fields (e.g., an account number), the check digit must be calculated at some point prior to data entry. Thereafter, the check digit is always used as part of the number. As the entry operator keys the field containing the check digit, the system computes a check digit for that field. If the computed and keyed check digits are the same, the field is accepted. Using the check digit feature of the system makes verification of the field unnecessary by guaranteeing the accuracy of the field.

The supervisor can enter up to 15 different check digit routines in the Check Digit Library. Each routine must be assigned a library reference number (1 through 15) prior to entry in the library. Once the routine is assigned a number and entered in the library, it is held on disk until called-up by an input format to validate a specific field keyed by the operator. At field end (the field is released by the operator), the system executes the specified check digit routine on the field.

If the keyed field and the check digit are equal, data entry is continued. If the keyed field and the check digit are not equal, the system displays an error message, sounds an error tone, and allows the field to be rekeyed. The operator must then rekey the field or enter the specified override character or error flag in the last position of the field.

In addition to validating a check digit, the system can generate a check digit for a field entered by an operator. This function can be specified for any or all numeric or alphameric data fields by the supervisor when coding the record format. Both features allow the supervisor to specify that multiple contiguous fields be calculated as one check digit field. Again, this is specified by the supervisor when coding the input format. The "80" *Series Formatting Techniques Manual* discusses check digit coding.

When the Check Digit Library is selected by the supervisor, the system displays the Check Digit Library Options List (Figure 5-9). This list provides the ability to assign, read or write check digits. These options are discussed in the following paragraphs.

The image shows a terminal screen with a menu titled "CHECK DIGITS". The menu contains three options: "A ASSIGN", "B READ", and "C WRITE". Below these options is a prompt "SELECTION □" followed by a small black dot. The entire menu is enclosed in a trapezoidal border.

Figure 5-9. Check Digit Library Options List

- Assign – This option is used to create or change a check digit routine, store the routine on disk, and assign the check digit routine to a library reference number. This number is later used by the supervisor to associate a check digit routine with an input format. To create a check digit routine select (A) ASSIGN, from the options list and enter the library reference number (1 – 15) which will be associated with that routine. Once a number (1 – 15) is entered, the message "HIT RELEASE TO PROCEED; OTHERWISE HIT HELP" is displayed. When the release key is depressed, the system displays a check digit format (Figure 5-10).

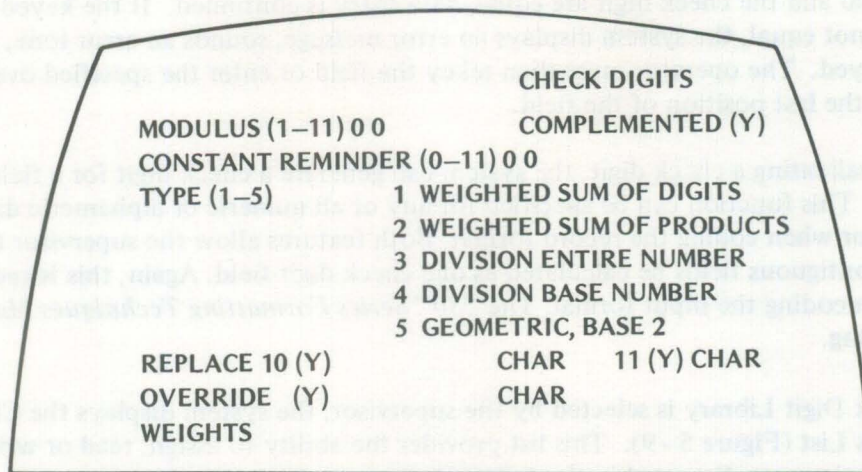

Figure 5-10. Check Digit Format

- **Read** – This feature is used to read a previously written tape containing check digit formats into the Check Digit Library. To execute the Read option, select (B) READ from the Check Digit Options List and the tape unit to be used. Once the tape unit is selected, the system executes the read operation.
- **Write** – This option is used to write the contents of the Check Digit Library to tape. To execute a write operation, select (C) WRITE from the Check Digit Options List and the tape unit to be used. Once the tape unit is selected, the system executes the write operation.

NOTE

The Check Digit Library is unique from all other libraries, e.g., Standard Job, Input Format, Record and Batch End Edit, Output and Sort Program Libraries, etc., in that the existence of duplicates in the Check Digit Library is permitted; that is, the system will not display an error message if a check digit routine, conforming to one already assigned in the Check Digit Library file, is entered.

WARNING

Each time a library tape is read, e.g., Read All Libraries Operation or a tape containing just the Check Digit Libraries, the check digit routines in the system are destroyed and replaced with the routines contained on the tape being read.

Check Digit Format

The system uses the conventions of Examine Mode when displaying the check digit format (Figure 5-10), via the Assign Option. To enter or change any part or parts of a check digit routine, hold down the RCD key and depress COR. Once the check digit routine is entered or corrected, the HELP Key is depressed to return to the Supervisor HELP List.

The following is an explanation of the terms that appear on the Nixdorf Check Digit Format (Figure 5-10).

- **Modulus** – A check digit is derived via the division of a combination of numbers by a number called the modulus. Therefore, if the modulus is 10, the calculation is referred to as a Modulo 10 Check Digit. There are four methods of combining the digits of the field to be checked (referred to as a base number); these methods are discussed under *Type*. A legal modulus number may be any number from 1 to 11. The most commonly used check digits are Modulo 7, 9, 10, and 11.
- **Uncomplemented** – When the result of a check digit computation is used as the check digit, the check digit is referred to as an uncomplemented check digit (a standard check digit), e.g., Modulo 10.
- **Complemented** – When the result of a check digit computation is subtracted from the modulus, the resulting check digit is referred to as a complemented check digit (a non-standard check digit), e.g., Modulo 10 complemented.
- **Constant Remainder** – All check digit computations allow for the specification of a constant remainder. Normally, the constant remainder is specified as 00 (field release), as in the case of the standard Modulo 7, 10 and 11 check digits; however, the constant remainder always figures into the check digit calculation (even if specified as 00), as illustrated by Figure 5-15, Step 3.
- **Type** – The system provides five methods of combining numbers in the calculation of a check digit. These methods are discussed below:
 1. **Weighted Sum of Digits** – Each character position of the base number (the number to be checked, and to which the check digit is appended) is individually assigned a weighting factor from right to left. In computing the check digit, each digit of the base number is individually multiplied by its assigned weight. All digits of the sum of digits are then added together to form an intermediate result which will be divided by the modulus.

Base Number	9	3	5	7	2
x					
Weights	<u>1</u>	<u>2</u>	<u>1</u>	<u>2</u>	<u>1</u>
(to obtain digits)	9	6	5	14	2

$$\text{Sum of Digits} = 9 + 6 + 5 + 1 + 4 + 2 = 27$$

Therefore, 27 is the intermediate result.

NOTE

From this point the calculation of a check digit is identical for all types (refer to Figure 5-15).

2. **Weighted Sum of Products** – As with the weighted sum of digits, each digit of the base number is multiplied by its weight. All the products are then added together to form an intermediate result which will be divided by the modulus.

Base Number	1	6	6	1	2	3
x						
Weights	<u>7</u>	<u>6</u>	<u>5</u>	<u>4</u>	<u>3</u>	<u>2</u>
(to obtain products)	7	36	30	4	6	6

$$\text{Sum of Products} = 7 + 36 + 30 + 4 + 6 + 6 = 89$$

Therefore, 89 is the intermediate result.

NOTE

From this point the calculation of the check digit is identical for all types (refer to Figure 5-15).

3. **Division of Entire Number** – The entire number, including the units (check digit) position is treated as the number to be divided by the modulus to determine an intermediate result.

NOTE

The entire number is = RSLT1 (refer to Figure 5-15). At this point the check digit is calculated identically to Steps 1 and 2 above.

4. **Division of Base Number** – The base number, excluding the units (check digit) position, is treated as the number to be divided by the modulus to determine an intermediate result.

NOTE

The base number is = RSLT1 (refer to Figure 5-15). At this point the check digit is calculated identically to Steps 1, 2, and 3 above.

5. **Geometric, Base 2** – This method of deriving a check digit is the same as that for the Weighted Sum of Products check digit, except that the weight specifications represent powers of two.

- Replace 10 (Y) – This provides the supervisor with the ability to replace a Modulo 10 Check Digit with a single character while still retaining the original value of 10, e.g., replace 10 with 0; replace 10 with 1. This must be done to allow for the restriction of a single character check digit.

NOTE

Whenever a Modulo 10 Check Digit is utilized, the Replace 10 (Y) question must be answered with a Y, and 10 replaced with a character. If this is not done, the message "CHECK DIGIT ERROR" will be displayed if the calculation of the field equals 10.

- Replace 11 (Y) – When Modulo 11 Check Digit is utilized, the Replace 11 (Y) question must be answered with a Y, and 11 replaced with a character. This is done for the same reasons discussed under Replace 10 (Y).

NOTE

If a Modulo 11 Check Digit is specified, the Replace 10 (Y) and 11 (Y) questions must both be answered with a Y, and 10 and 11 replaced with a single character. If these questions are not answered, and the result of the calculation equals 10 or 11, the message "CHECK DIGIT ERROR" will be displayed.

- Override (Y) – When specified, this routine allows the entry operator to substitute a designated character for an incorrect check digit. This is used when there are infrequent exceptions to a check digit field; for example, when the process of changing account numbers over is initiated, but the changeover is not complete.

NOTE

If the override character or either replace character is non-numeric and the check digit field is specified as numeric only, the character must be entered as a Numeric Only Exception.

- Weights – The system allows a check digit field or combination of fields to be of any length specified. To accommodate this feature, a sequence of up to 20 different repeating weights may be specified. The first position entered in the check digit format under weights applies to the "units" position of the base number. The second position applies to the "tens" position, etc. If fewer weights than field positions are entered, the progression will be repeated for the length of the field as illustrated by Figure 5-11.

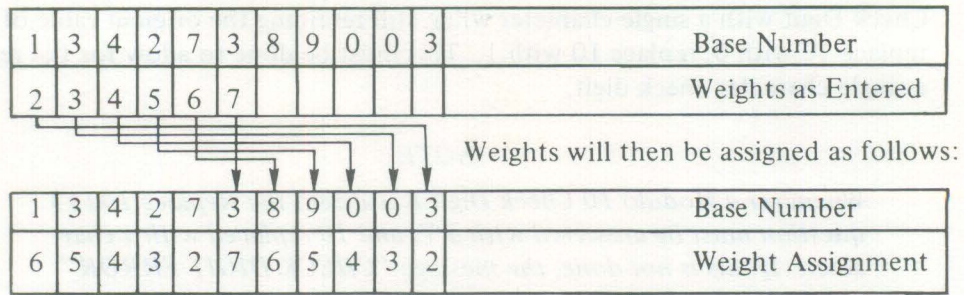

Figure 5-11. Weight Assignment

Check Digit Calculations

The following examples provide the method of calculation for Modulus 7, 10 and 11 Check Digits.

- **Modulus 7 Check Digit** (refer to Figure 5-15)
 1. Base Number = 134273 (*Type 4* move base number to RSLT1)
 2. RSLT1 = $134273/7 = 6(\text{REM}1)$
 3. If $6(\text{REM}1) \leq \emptyset(\text{CR})$ go to Step 5.
 4. $7(\text{Modulus}) + 0(\text{constant remainder}) = 7(\text{CR})$
 5. $7(\text{CR}) - 6(\text{REM}1) = 1$ (uncomplemented check digit)
 6. Complemented check digit = $7 - 1 = 6$

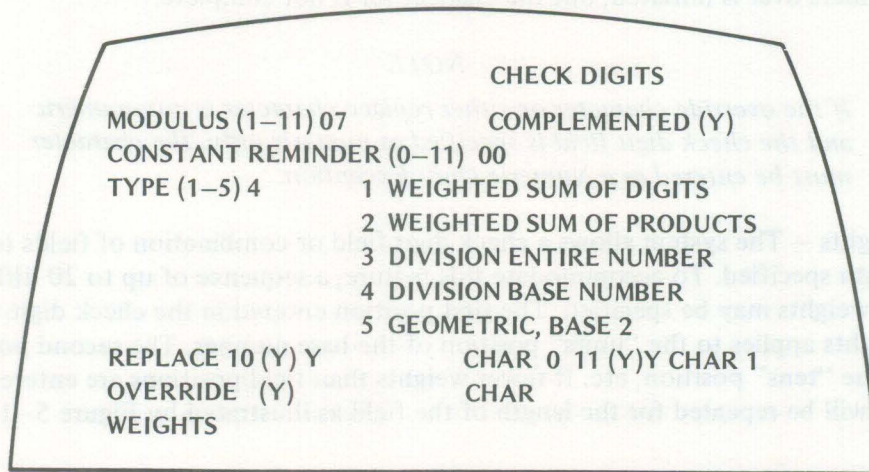

Figure 5-12. Standard Modulus 7 Check Digit

● **Modulus 10 Check Digit** (refer to Figure 5–15)

1. Base Number	1 3 4 2 7 3
Type 1	$\begin{array}{r} 1\ 2\ 1\ 2\ 1\ 2 \\ \hline 1\ 6\ 4\ 4\ 7\ 6 \end{array}$

$$1 + 6 + 4 + 4 + 7 + 6 = \text{RSLT1}$$

$$\text{RSLT1} = 28$$

2. $\frac{\text{RSLT1}}{\text{MOD}} = 8(\text{REM1})$
 $\frac{28}{10} = 8(\text{REM1})$

3. $8(\text{REM1}) \leq 0(\text{CR}) \rightarrow$ go to Step 5

4. $10(\text{MOD}) + 0(\text{CR}) = 10(\text{CR})$

5. $10(\text{CR}) - 8(\text{REM1}) = 2(\text{uncomplemented check digit})$

6. Complemented check digit = $10(\text{MOD}) - 2(\text{CD}) = 8$

7. If $\text{CD} = 10 \rightarrow$ replace CD with 0

CHECK DIGITS	
MODULUS (1–11) 10	COMPLEMENTED (Y)
CONSTANT REMINDER (0–11) 0 0	
TYPE (1–5) 1	1 WEIGHTED SUM OF DIGITS
	2 WEIGHTED SUM OF PRODUCTS
	3 DIVISION ENTIRE NUMBER
	4 DIVISION BASE NUMBER
	5 GEOMETRIC, BASE 2
REPLACE 10 (Y) Y	CHAR 0 11 (Y) Y CHAR 0
OVERRIDE (Y)	CHAR
WEIGHTS 21	

Figure 5–13. Standard MOD 10 Check Digit

● **Modulus 11 Check Digit** (refer to Figure 5-15)

1. Base Number	1	3	4	2	7	3
<i>Type 2</i>	7	6	5	4	3	2
	7	18	20	8	21	6

$$7 + 18 + 20 + 8 + 21 + 6 = \text{RSLT1}$$

$$\text{RSLT1} = 80$$

$$2. \frac{\text{RSLT1}}{\text{MOD 11}} = \frac{80}{11} = 3(\text{REM1})$$

3. $3(\text{REM1}) \leq 0(\text{CR}) \rightarrow$ go to Step 5

$$4. 11(\text{MOD}) + 0(\text{CR}) = 11(\text{CR})$$

$$5. 11(\text{CR}) - 3(\text{REM1}) = 8(\text{uncomplemented check digit})$$

$$6. \text{Complemented check digit} = 11(\text{MOD}) - 8(\text{CD}) = 3$$

7. If $\text{CD} = 10 \rightarrow$ Replace CD with 0

8. If $\text{CD} = 11 \rightarrow$ Replace CD with 1

CHECK DIGITS	
MODULUS (1-11) 11	COMPLEMENTED (Y)
CONSTANT REMINDER (1-11) 00	
TYPE (1-5) 5	1 WEIGHTED SUM OF DIGITS
	2 WEIGHTED SUM OF PRODUCTS
	3 DIVISION ENTIRE NUMBER
	4 DIVISION BASE NUMBER
	5 GEOMETRIC, BASE 2
REPLACE 10 (Y) Y	CHAR 0 11 (Y) Y CHAR 1
OVERRIDE (Y)	
WEIGHTS 2340	

Figure 5-14. Standard MOD 11 Check Digit

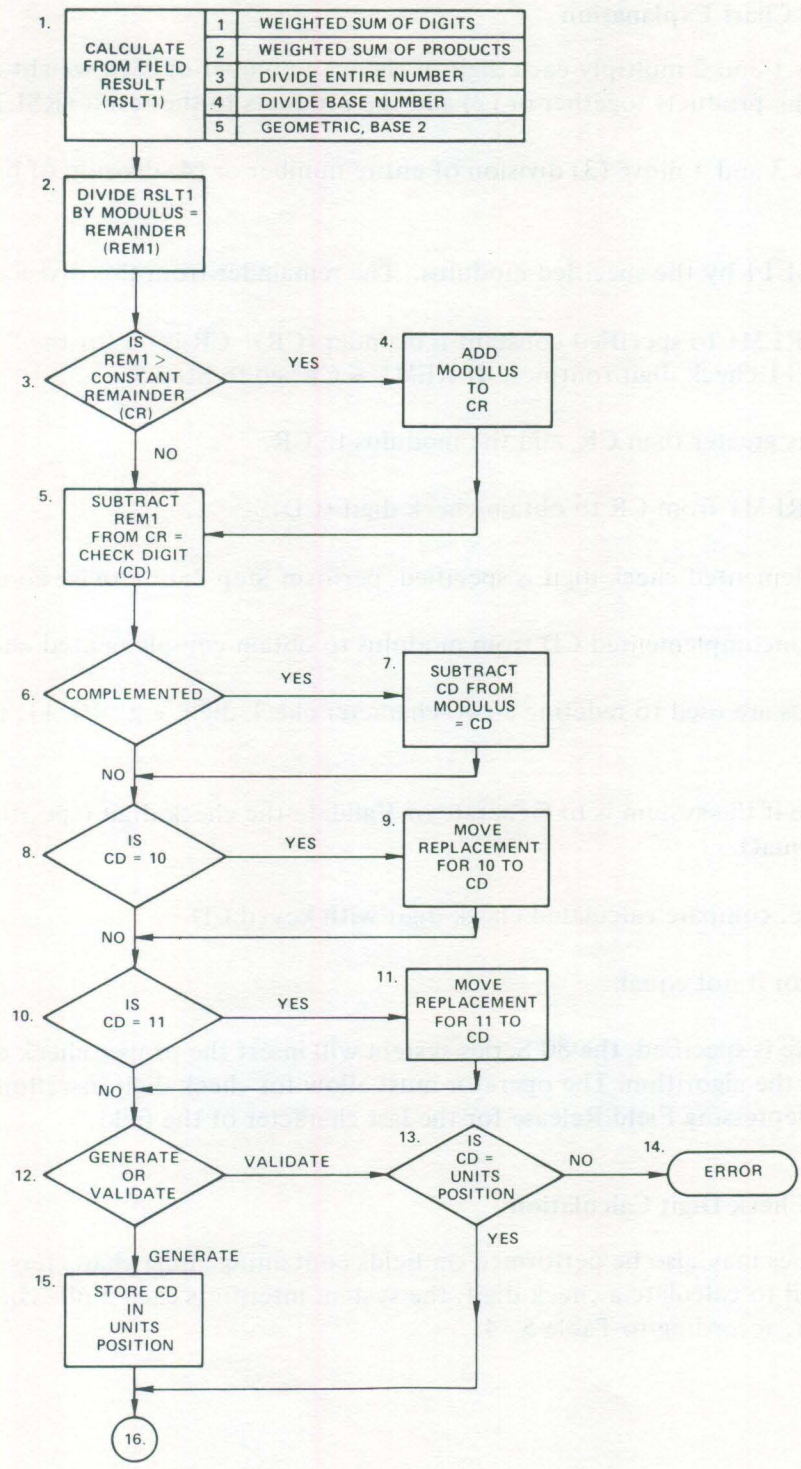

Figure 5-15. Check Digit Calculation Flow Chart

Check Digit Flow Chart Explanation

1. For *Types* 1 and 2 multiply each digit of the base number of each weight and (1) add all digits of the products together or (2) add the products to the result (RSLT1).

For *Types* 3 and 4 move (3) division of entire number or (4) division of base number to RSLT1.
2. Divide RSLT1 by the specified modulus. The remainder from this division is REM1.
3. Compare REM1 to specified constant remainder (CR). CR is 00 for the "standard" MOD 7, 9, 10 and 11 check digit routines. If $REM1 \leq CR$, go to Step 5.
4. If REM1 is greater than CR, add the modulus to CR.
5. Subtract REM1 from CR to obtain check digit (CD).
6. If a complemented check digit is specified, perform Step 7; otherwise go to Step 8.
7. Subtract uncomplemented CD from modulus to obtain complemented check digit.
- 8/11. These steps are used to redefine a two-character check digit, e.g., 10, 11, to a one-position digit.
12. Determine if the system is to Generate or Validate the check digit (specified within the Input Format).
13. If Validate, compare calculated check digit with keyed CD.
14. Signal Error if not equal.
15. If Generate is specified, the 80 Series system will insert the proper check digit after executing the algorithm. The operator must allow for check digit insertion by keying a space or depressing Field Release for the last character of the field.

Alpha Character Check Digit Calculation

Check digit routines may also be performed on fields containing alpha characters. When alpha characters are used to calculate a check digit, the system interprets each alpha character as a numeric character, according to Table 5-4.

TABLE 5-4. CHECK DIGIT VALUES FOR ALPHA CHARACTERS

Alpha Character	A	B	C	D	E	F	G	H	I
Alpha Character	J	K	L	M	N	O	P	Q	R
Alpha Character		S	T	U	V	W	X	Y	Z
Numeric character used to calculate check digit	1	2	3	4	5	6	7	8	9

READ ALL LIBRARIES

The Read All Libraries feature of the 80 Series system allows the supervisor to read library formats from tape to disk. This libraries feature complements the read feature of the individual Library Options Lists by allowing the supervisor to read multiple formats written to tape from each library in a single operation.

The Read All Libraries feature reads only tapes created by the Write Libraries feature of the system or will read a tape containing libraries which were written individually in the proper order via the individual write options of the Library Options Lists. The order in which the system reads a library tape via the Read All Libraries feature is identical to the order in which the libraries appear on the following display.

LIBRARIES	
A	STANDARD JOB
B	INPUT FORMAT
C	RECORD END EDIT
D	BATCH END EDIT
E	OUTPUT PROGRAM
F	SORT PROGRAM
G	COMMAND SEQUENCE
H	CODE SET CONVERSION
I	OPERATOR STATISTICS
J	CHECK DIGITS
K	READ ALL LIBRARIES
L	WRITE LIBRARIES
SELECTION <input type="checkbox"/>	

NOTE

Operator Statistics are not read during a Read All Libraries operation. A Read Operator Statistics feature is not available because of the unique nature of the Operator Statistics Library; that is, operator statistics are accumulated as a batch on disk, rather than stored on disk as a library file. If it is desirable to read operation statistics onto disk after a Write Statistics operation, a Read Batch operation (Batch I/O Operations) can be executed.

If duplicate libraries are encountered by the system during a Read All Libraries operation, the system displays the message "NAME ALREADY EXISTS OR IS INVALID", sounds an error tone, and displays the name of the duplicate library. Should this situation arise, the supervisor need only depress the RESET Key to continue the operation and discard the duplicate.

WARNING

Each time a library tape is read, e.g., Read All Libraries Operation or a tape containing just the Check Digit Libraries, the check digit routines in the system are destroyed and replaced with the routines contained on the tape being read.

WRITE LIBRARIES

The Write Libraries feature allows the supervisor to write associated formats from each library (contained on disk) to tape in a single operation. When this feature is selected, the system requests the tape unit to be used in the operation. Once the tape unit is selected, the system requests the name of associated formats to be written from each library. Once the name(s) is specified and the REL key depressed, the system writes the formats to tape and automatically writes a tape mark at completion of each library. Once this operation is completed, the system rewinds the tape automatically. This Libraries feature complements the Write feature of the individual library options lists by allowing the supervisor to write multiple library formats in a single operation.

The order in which the 80 Series system writes a library tape during a Write Libraries operation is identical to the order in which the libraries appear on the display presented under Read All Libraries.

NOTE

Operator statistics are not written during a Write Libraries operation. All check digits are written during this operation, and are the last formats written to tape.

The Asterisk Processor is used to write all library formats to tape, i.e., asterisks in all eight positions. To accommodate the capability to write a set of formats from each library, the supervisor should code associated formats with the same prefix, e.g., PAY -----. Coding library formats in this manner allows the supervisor to write to tape all formats in all libraries within this set, e.g., beginning with PAY, by selecting the Write Libraries feature and entering PAY*****. This operation would produce a library tape with the following library formats:

- All Standard Jobs beginning with PAY.
- All Sort Programs beginning with PAY.
- All Input Formats beginning with PAY.
- All Command Sequences beginning with PAY.
- All Record End Edits beginning with PAY.
- All Code Sets beginning with PAY.
- All Batch End Edits beginning with PAY.
- All Check Digits.
- All Output Programs beginning with PAY.

SECTION 6 SYSTEM OPERATIONS

The System Operations List provides system management features which provide both hardware and software control as well as aid in management and flow of data. The following paragraphs describe the features shown in the display below:

```
SYSTEM OPERATIONS  
A  ENTER DATE           H  DIAGNOSTIC MODE  
B  DISK STATUS          I  SYSTEM TAPE CODE  
C  SYSTEM SAVE          J  TYPEWRITER OVERSIGN  
D  ASSIGN TAPE UNIT     K  OPTIMIZE SYSTEM  
E  CHANGE PASSWORD     L  AUTO BATCH LOAD  
F  NUM ONLY EXCEPT'S M  FORMAT DISK  
G  COMM PARAMETERS  
SELECTION 
```

ENTER DATE

The Enter Date feature is used in conjunction with the Batch Status and Operator Statistics features of the 80 Series system. Once a date is entered, the system will associate that date with all batches started while the date is in effect. The date can be entered as calendar (month/day/year or Julian, as well as any other desired method providing the method utilizes six numeric positions or less).

DISK STATUS

This feature provides the ability to view the percentage of disk that is being used for data, the percentage of disk being used for the system (80 Series operating system and all libraries), and the identity of the software. Use of this feature allows efficient data management by enabling the supervisor to determine when to write data to tape or delete data in order to prevent a full disk. Disk Status is displayed as follows when the option is selected from the System Operations List:

"DATA nn %SYSTEM nn %"

Disk-Cartridge Systems (2.4–9.6 Mbytes)

On disk-cartridge systems the two percentages are added for warning purposes because all new libraries (part of the system area) and data may be intermixed on the disk. As the *TOTAL* approaches full, appropriate warning messages are displayed on keystations which are writing to disk. For example, DATA 60% SYSTEM 38% represents 98% disk utilization and would result in the display of the error message "DISK 98% FULL." Each time the message is displayed, it is accompanied by an error tone, and the RESET Key must be depressed to continue operation. The users should notify the supervisor when this occurs.

When the disk reaches 99% capacity, a warning message ("DISK 99% FULL") is displayed and an error tone sounds with every attempt to write data. If the RESET Key is depressed, the message "PLEASE TAKE ACTION" is displayed, and an error tone sounded. Although operation may be continued by depressing the RESET Key again, *it is imperative that the users notify the supervisor.* If no action is taken and data entry is continued, eventually the system will display the message "DISK IS FULL." The system then ignores all subsequent keystrokes and either a System Save must be loaded or an ABL performed to continue operation.

NOTE

It is important to note that in order to get into a disk full condition, repeated warnings must be ignored.

Disk-Pack Systems (33 Mbytes)*

On disk-pack systems, the data and system disk areas are independent and mutually exclusive. The operating system, libraries, and indexed value tables are retained in a specific eight-megabyte section of the disk pack. The remainder of the disk (25 MB) is used only for data.

As *either* the system section *or* the data section of the disk approaches full status, the keystations accessing that section will receive warning messages with each attempt to write to disk. For example, DATA 40% SYSTEM 98%, DATA 98% SYSTEM 75% and DATA 98% SYSTEM 98% would produce the "DISK 98% FULL" warning message accompanied by an error tone. Warnings would continue, as noted previously, in an attempt to prevent a full disk condition.

SYSTEM SAVE

A System Save is essentially a "snapshot" of *allocated* disk sectors, i.e., *only* the disk space being used, which preserves data and system information (libraries, operator statistics, etc.) currently residing on disk by writing them to tape. The time and tape space required to take a Save is proportional to the amount of information resident on the disk. Reloading a System Save using a Cold Start leaves the system in the exact condition it was when the Save was taken.

*System 480 only.

Because System Saves can be reloaded, they provide excellent backup in the event of a system malfunction. As a result, it should be standard operating procedure to take System Saves at regular intervals during the day, such as mid-morning break, lunch break, mid-afternoon break, and the end of the day (or shift).

Using the above schedule protects the supervisor from ever losing more than two working hours of data. Taking the Save requires only a few minutes and will prevent the loss of many hours of work. Normal procedure calls for maintaining a library of three System Saves, always recycling the oldest Save when a new one is taken.

NOTE

The supervisor should also insure that an up-to-date version of all library formats and value tables is also maintained.

Save

To execute a System Save, the following procedure should be used:

- Mount a tape containing a Write-Ring.
- Inform the operators to discontinue keying. Although it is not necessary for the operators to terminate batches, it is *desirable* to complete all dynamic operations, e.g., a delete operation, sort, or termination of batches.

NOTE

If batches are not terminated and the System Save is reloaded, the operators must depress the HELP Key, and select Return To Data from the Batch HELP List, to redisplay the batch that was active prior to the System Save.

- Select System Operations from the Supervisor HELP List.
- Select System Save from the System Operations List.
- Select the desired tape unit.
- Once the tape unit is selected, the entire system contents are written onto tape, i.e., the contents of the processor memory as well as data and libraries contained on the disk. When the Save is completed, the System Operations List is redisplayed on the terminal which requested the System Save; the remaining terminals are not affected and data entry operations may be continued.

NOTE

The message "TAPE UNIT NOT READY" will appear if the selected tape drive does not have an illuminated REMOTE or ON LINE light. If a problem is discovered by the system while taking a System Save, the message "SYSTEM SAVE QUESTIONABLE" is displayed; check the Write-Ring and repeat the procedure. If this message appears again, Nixdorf Field Service should be contacted. If the output buffer is being used, the message "OUTPUT BUFFER NOT AVAILABLE" is displayed. Repeat the procedure when the output buffer is free.

- Remove the System Save tape from the Tape drive. Remove the Write-Ring from the tape reel and affix a label indicating the tape density, data contained on the tape, the date, (day, month, year), and the hour of the Save, on the reel.

Generating a Multi-Reel System Save

A System Save may be performed using multiple reels of tape. This feature was designed to accommodate the additional storage provided by the 33 Mbyte unit.

If the End-Of-Tape (EOT) marker is sensed before a Save is completed, an EOF (End-Of-File tape mark) is written, the tape rewinds, and the message "MOUNT REEL # -" is displayed. When the rewind is completed, the message "HIT REL TO PROCEED; OTHERWISE HIT HELP" will be displayed. The following procedure should be utilized to complete a multi-reel Save:

- Another tape with a Write-Ring should be mounted, ensuring that the tape is at the load point (BOT). When the REL Key is depressed at the keystation initiating the Save, the next reel will begin with a header record containing the reel number and disk status (to make each tape unique) followed by additional records read from the disk.
- As many reels as necessary may be mounted, using the procedure outlined above, until the Save is completed.
- The last tape record of the last reel is followed by an EOF mark. When the Save is completed, the System Operations List is redisplayed on the terminal which initiated the Save, and the remaining keystations may resume operations.

NOTE

After removing the Write-Ring, the user should label each reel with a unique Save identifying label (Tape Density, Date, Hour, and Reel # - of -) to ensure that sequential reel numbers from separate Saves are not confused at a later time.

Loading a Multi-Reel System Save

Multi-reel Saves must be read into the system in the order in which they were written. As each trailer record (EOF) on all but the last Save tape is read, the messages "MOUNT REEL # -" and "HIT REL TO PROCEED" will be displayed on all keystations as the last Save tape is rewound. Depressing the REL Key after mounting each additional Save tape will continue the loading procedure.

Each Save tape's header record is used to ensure that the tape is indeed the continuation of a particular Save. If not, the message "WRONG REEL # " will be displayed, and the tape will be rewound immediately. The proper reel may then be mounted, and will be read when the REL Key is depressed at any terminal. This procedure is repeated for each sequential tape until the EOF trailer on the last reel indicates that all reels for the Save have been loaded.

WARNINGS

- If a Warm Start is attempted before any Cold Start loading is completed, the entire load must be repeated from the beginning.
- Since the keyboard is partially operative during Tape Cold Start, it is important that there be *NO* attempt to key except as specifically directed in the procedure.
- The ECHO feature must never be activated during the Cold Start process.

ASSIGN TAPE UNIT

The Assign Tape Unit feature of the 80 Series system allows the supervisor to assign a specific number to each tape unit in a multiple tape system. Four tape units of varying characteristics can be maintained simultaneously by the system. The tape units offered by Nixdorf are 7 or 9-track, IBM-compatible, magnetic tape units with packing densities of 556, 800 or 1600 bits per inch and a read/write of 25 inches per second.

When Assign Tape Unit is selected from the System Operations List, the following display is presented:

SYSTEM OPERATIONS					
	UNIT (0 - 3)	7-CH ODD	7-CH EVEN	9-CH 800	9-CH 1600
TAPE 1	0			X	
TAPE 2	0				X
TAPE 3	0	X			
TAPE 4	1		X		

(KEY X TO INDICATE ASSIGNMENTS)

To assign a number to a specific tape unit, the cursor is positioned at the desired tape assignment and the COR and X Keys are depressed sequentially. The HELP Key may be depressed to return to the System Operations List. The assignment of tape units is completely arbitrary. The only criterion for assignment is ease of operation, i.e., the most frequently used tape unit might be assigned as tape unit 1.

This feature works in conjunction with all 80 Series system operations requiring selection of a tape unit, e.g., Write Status, Write Libraries, Read All Libraries, etc. When an operation requiring a tape unit is selected, the system requests the selection of tape unit 1-4. If two tape units are given the same assignments, the message "IMPROPER TAPE UNIT ASSIGNMENT" appears on the screen and the previous parameters are displayed.

SYSTEM TAPE CODE

This feature enables the supervisor to specify by name one code set, contained in the Code Set Conversion Library, as the default case for writing to tape. Once a code set name is entered, e.g., BCD, via this feature, the supervisor can Field Release through code set fields displayed by the system, if the default code set is desired for that particular operation.

This operation does not hamper the use of any other code set residing in the system. Rather, it allows the supervisor to rapidly specify a particular code set via the FIELD RELEASE Key during operations such as Write Batch, Write Batch Log, or Read Batch. If other than the default code set is desired for an operation, the supervisor simply enters the code set name.

NOTE

The standard Nixdorf system code set is EBCDIC. To reassign EBCDIC as the default case, Field Release through the System Tape Code field.

System Tape Code is intended as a time-saver. If a particular code set such as BCD is used for most operations, the supervisor can specify this code set as the default case, thereby allowing use of the FIELD RELEASE Key to specify the code set to be used in the operation. The alternative to this feature is the repeated entry of a code set name during all input/output operations.

Once a code set name is entered under this feature, the supervisor can elect to delete/change the name by selecting this feature and keying a new code set name. The only criterion for entry is the existence of the specific code set in the Code Set Conversion Library. (See Section 5 for a full discussion of this library.)

Four-By-Three Tape Packing

Four-by-three (4/3) tape packing permits the efficient storage of 6-bit characters (used by Honeywell Information Systems Series 2000 and 6000) on 9-track tapes. If 6-bit characters were stored one character per frame, as on 7-track tapes, two tracks would be wasted (Figure 6-1).

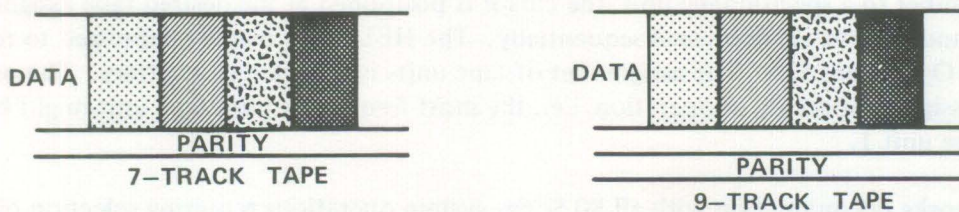

Figure 6-1. Unpacked Data (6-Bit Characters) on 7-Track and 9-Track Tape

The 4/3 packing technique puts four 6-bit characters on three tape frames in the following manner:

- Frame 1: first character and first 2 bits of second character;
- Frame 2: last 4 bits of second character and first 4 bits of third character;
- Frame 3: last 2 bits of third character and all of fourth character (Figure 6-2).

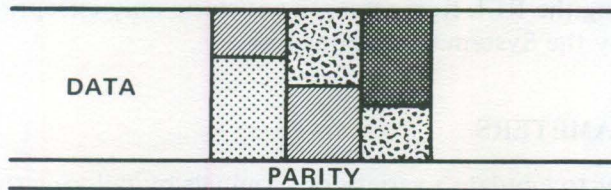

Figure 6-2. Packed Data (6-Bit Characters) on 9-Track Tape

To use 4/3 packing, follow the procedures below:

- Assign the input/output operation to a unit designed to handle 9-track tapes.
- Specify an appropriate tape output code (an octal code such as H-2000 or H-6000 – see Appendix B).

If no unit is assigned for 9-track tapes, assign one by selecting (D) from the System Operations HELP List.

If an appropriate code is not available, you must put one in the system by selecting (H) Code Set Conversion from the Libraries HELP List and enter the desired code set. The notation question for the Code Set Conversion Library permits 2 to be specified for Series 2000 and 6 for Series 6000 (in addition to H for hexadecimal and O for octal).

CHANGE PASSWORD

Change Password is a security feature of the 80 Series system. This feature allows the supervisor to enter a new password by keying any combination of five alpha, numeric or special keyboard characters, including spaces. This option enables as frequent changing of the password as necessary to assure full security and prevention of unauthorized access to processing operations.

NUMERIC ONLY EXCEPTIONS

This feature is used in conjunction with the field use portion (Column 6) of the input format and allows the supervisor to specify four characters as numeric only exceptions. Since numeric only specifies that ordinarily only the digits 0 through 9 can be entered in a field, this feature permits the use of any four characters, such as: \$, ¢, +, -, etc., as required for a particular application. These exceptions may be entered, removed, or changed at the supervisor's discretion. However, care should be exercised when making changes to existing numeric only exceptions to insure that *active formats will not be affected*.

The following procedure should be used to specify numeric only exceptions:

- Select (F) Numeric Only Exceptions from the System Operations List.
- When the message "ENTER NUMERIC ONLY EXCEPTIONS ----" is displayed, key the exceptions in the four delimiter spaces. If fewer than four exceptions are to be used, Field Release through the excess spaces.
- The message "HIT REL TO PROCEED; OTHERWISE HIT HELP" will then be displayed. Depressing the REL Key enters the numeric only exceptions and the system will then redisplay the System Operations List.

COMMUNICATIONS PARAMETERS

This feature enables the user to emulate a variety of terminals by tailoring the Nixdorf communications software in the areas of data formatting, data discipline, bids and retries, and identification. The tailoring is effected through 12 communications parameters which are set to best fit the user's communications configuration.

When Communications Parameters is selected from the System Operations HELP List, a value can be keyed for each parameter. Once a value is entered, the parameter retains that value unless explicitly changed. Refer to Table 4-3 COMMUNICATIONS PARAMETERS for user responses and default values to the system prompts.

A user needing more than one communications configuration should determine the parameter set for each configuration and code each set of parameters as a Command Sequence. A more detailed discussion of the operations used for Communications Parameters is provided in Section 4.

DIAGNOSTIC MODE

The Diagnostic Mode List is obtained by selecting (H) from the System Operations List. This list allows the user to initiate Communications Dynamic Trace and the Replace Disk Pack options. All other functions listed on the Diagnostic Mode List are to be used by authorized Nixdorf Field Service personnel *only*.

Echo

The ECHO feature is a training aid which displays on terminals 1-16 the keystrokes and responses occurring on a designated "master" terminal. Echo is activated by raising DATA Switch 0 on the central processor panel (Figure 6-3) and by raising the appropriate combination of DATA Switches (12-15) to designate the master terminal (refer to Table 6-1).

TABLE 6-1. DATA SWITCH ARRANGEMENT FOR ECHO MODE

Desired Master Terminal	Required Switch Setting				Desired Master Terminal	Required Switch Setting			
	12	13	14	15		12	13	14	15
1		none			9	X			
2				X	10	X			X
3			X		11	X		X	
4			X	X	12	X		X	X
5		X			13	X	X		
6		X		X	14	X	X		X
7		X	X		15	X	X	X	
8		X	X	X	16	X	X	X	X

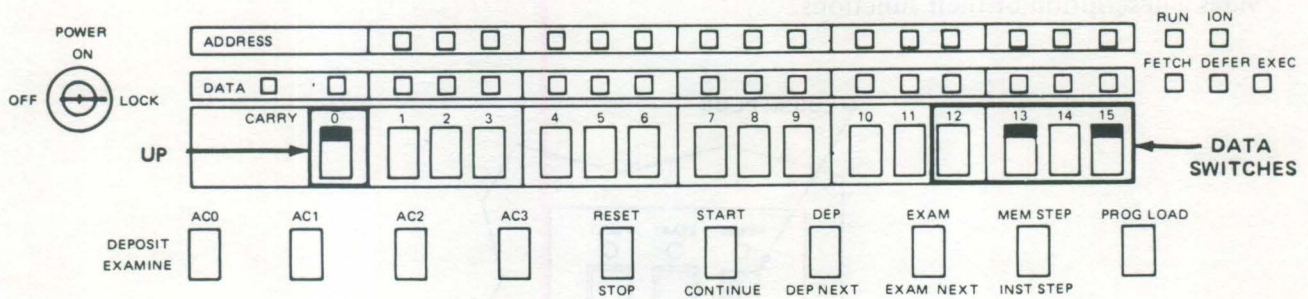

Figure 6-3. Central Processor Panel with ECHO ON and Terminal 6 Designated as the "Master"

Terminals 1–16 should be inactive (displaying the Operator HELP List) when ECHO is activated. Once ECHO is active, keystrokes are ignored on terminals 1–16 except for the master terminal. Terminals 17–32 may be used for any other purposes without interference.

When ECHO is not in use, DATA Switch 0 *must* be restored to its *original* condition, i.e., DOWN. Good practice would also dictate that switches 12 through 15 be returned to the down position.

WARNING

The ECHO function must *not* be activated during the taking or loading of a System Save tape.

NOTE

Front Panel is required for ECHO.

Communications Dynamic Trace (BISYNC ANALYZER)

This option, activated from the Diagnostic Mode List, may be used to monitor binary synchronous line control and text interchange. See Section 4 (Parameterized Communications) for a full discussion of this feature.

33 MEGABYTE DISK UNIT (System 480)

Nixdorf's 33 megabyte disk unit is a random-access, removable pack device used by the Central Processor for intermediate storage of system software, libraries and data. The disk unit is a logical extension of System 480's core memory and serves as a convenient and easily loaded storage medium.

A control panel is located on the left front panel of the disk unit (Figure 6–4); the power panel is located at the rear of the unit (Figure 6–5). Table 6–2 lists these controls and indicators and provides a description of their functions.

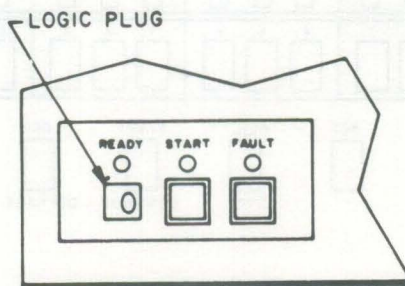

Figure 6–4. Operator Control Panel

TABLE 6-2A. OPERATOR CONTROL PANEL CONTROLS AND INDICATORS

CONTROL	FUNCTION
START SWITCH	Turns the drive ON and OFF. When the START Switch is depressed to turn the drive ON, the Start Indicator illuminates, the pack drive energizes, and the heads move to their home address. (Note – Prior to depressing the START Switch, the disk pack must be in place, the pack's canister must be removed, the dust cover must be closed, and the circuit breakers must be ON.) When the START Switch is depressed to turn the drive OFF, power is removed from the pack drive, the START Indicator light goes out, the heads are retracted from the disk, and disk rotation stops.
START INDICATOR	Illuminates when the START Switch is ON.
FAULT SWITCH	Clears the fault circuitry and extinguishes the FAULT Indicator.
FAULT INDICATOR	Illuminates in response to certain fault conditions. Should the FAULT Indicator illuminate, the condition should be cleared by depressing the FAULT Switch. A Nixdorf Field Service Representative should be informed of the frequency of these occurrences.
LOGIC PLUG	The LOGIC Plug is pre-set and does not require user control.
READY INDICATOR	Illuminates when the required rotational speed of the disk is attained and the heads are positioned.

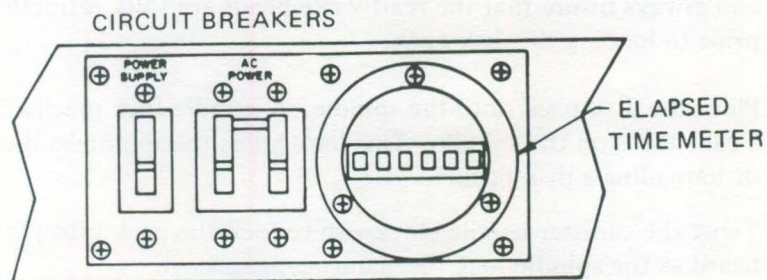

Figure 6-5. Power Panel

TABLE 6-2B. POWER PANEL CONTROLS AND INDICATORS

CONTROL	FUNCTION
AC POWER CIRCUIT BREAKER	Controls AC power.
POWER SUPPLY CIRCUIT BREAKER	Controls DC power to the logic chassis.
ELAPSED TIME METER	Active when power is applied by the circuit breakers. This meter records accumulated AC power-on time.

Loading a Disk Pack

The following procedure must be used to load a disk pack in the unit.

1. Ensure that the AC POWER Circuit Breaker is ON. (If a pack is constantly stored in the drive, the AC POWER Circuit Breaker should remain ON.) Note – AC POWER *must* also be ON prior to installing a disk pack.
2. Ensure that the POWER SUPPLY Circuit Breaker is ON.
3. Install a disk pack as follows:
 - a. Raise the dust cover at the top and front center of the disk unit to expose the drive spindle.
 - b. Lift the disk pack by the canister handle.
 - c. Disengage the canister's bottom dust cover from the disk pack using the knob in the center of the canister. Set the cover aside in a clean, dust-free area.

CAUTION

Avoid hard or abusive contact between the disk pack and spindle and always insure that the read/write heads are fully retracted prior to loading the disk pack.

- d. Place the disk pack onto the spindle. A spindle-lock mechanism is activated when a canister is on the spindle. This lock holds the spindle stationary while loading or unloading a disk pack.
- e. Twist the canister handle clockwise to lock the pack into place. A click will be heard as the spindle-lock mechanism engages.
- f. Lift the canister clear of the disk pack, place the bottom dust cover on the canister, and set it aside in a clean dust-free area.
- g. Close the unit's dust cover immediately to prevent dust from entering the unit.

To Replace Disk Pack

J -

F -

H - diagnostic mode

M - Replace disk pack

Do this before
shutting off system
daily - eliminates
"power fail" msg

you get a nicey
↳
chat awful

4. Depress the Operator Panel START Switch. The READY Indicator will illuminate when the disk unit has completed its start up sequence.
5. Perform a Warm Start. Note – This step may be skipped *only* when a System Save, ABL or Master System Tape is loaded. Should the disk pack unit lose AC power or be turned OFF, perform a Warm Start prior to resuming operation.

Replace Disk Pack

The following procedure must be followed to replace a disk pack.

1. Select the Replace Disk Pack option from the Diagnostic Mode List; the system then displays the message “HIT HELP TO PROCEED; OTHERWISE HIT HELP”.
2. Depress the REL Key to activate the option. (Depressing the HELP Key will return the system to the Diagnostic Mode List.) If no other terminals are active, all keystations will be locked out immediately and will display the message “REPLACE DISK PACK”.

NOTE

Keystations will remain locked out until the disk pack is replaced and a Warm Start is executed or until a Master System Tape, ABL or System Save is read onto the new disk pack.

3. If the system responds to the Replace Disk Pack request with the error message “OTHER TERMINALS ARE ACTIVE”, depress the RESET and REL Keys. This will cause the system to stop those operations being performed at the keystations and will allow the Replace Disk Pack operation to continue.
4. Depress the disk pack unit’s START Switch to extinguish the START Indicator. Check to ensure that the disk pack rotation has stopped. This requires approximately 20 seconds if the START Switch is used, or approximately 90 seconds if AC power is lost.

NOTE

Do not open the pack cover until pack rotation has stopped.

5. Raise the unit’s dust cover and insure that the heads are fully retracted. Place the plastic canister over the mounted disk pack so that the post protruding from the center of the disk pack is received into the handle of the canister. Twist the canister handle counter-clockwise until the disk pack is free of the spindle.

NOTE

Avoid hard or abusive contact between the disk pack and the spindle assembly.

Lift the canister/disk pack clear of the spindle and close the unit’s dust cover.

6. Place the bottom dust cover on the canister and turn the knob to secure it in place. Affix a date/time label, and store the pack in a clean, dust-free area.

WARNING

Failure to execute the Replace Disk Pack Option, as indicated, prior to removing a disk pack from the unit will result in an irretrievable data loss.

Disk Pack Transfer

A Nixdorf Field Service Representative should be asked to verify compatibility of the Read/Write head alignments on all 33 megabyte disk drives before packs are interchanged between those disk drives.

Disk Pack Handling

To ensure maximum disk pack life and readability, the following procedures should be observed:

1. Store disk packs in a computer room environment: 60° to 90°F; 10% to 80% relative humidity.
2. If disk packs must be stored in an environment different from that of the disk drive, allow two hours for temperature and humidity adjustment prior to use.
3. Never store disk packs in sunlight or in an environment unprotected from dust.
4. Store disk packs flat, not on edge; however, they may be stacked with similar canister type packs.
5. Always insure that both top and bottom canister covers are on the pack when not installed in the drive.
6. Use a felt tip pen or marker that does not produce residue when marking packs. Never use a lead pencil. Write on the label before applying it to the pack, and only use labels which will not leave a gum residue when removed.

TYPEWRITER OVERSIGN

The Typewriter Oversight option of the System Operations List allows the user to provide the software oversight capability to typewriter-type keystations (keypunch-type keystations are automatically provided with this feature). On a typewriter keyboard, the key to the left of the REL Key is used as the oversight key. It has the underscore and minus signs on the keytop and was selected as the oversight key because it is located in the same position on the keyboard as the OVERSIGN Key on the keypunch keyboard.

To place a minus oversight on a digit, depress the underscore/minus key and then the digit to be oversigned. To place a plus oversight on a digit, hold down the SHIFT Key while depressing the underscore/minus key, and then key the digit to be oversigned.

When the user selects this option, the system displays the message "TYPEWRITER OVERSIGN HELP = RESET, REL = SET." The supervisor may depress HELP to turn OFF the oversign capability or REL to provide the oversign capability.

OPTIMIZE SYSTEM

The system was designed and implemented as a data entry system which would operate 32 Key-stations and provide data entry priority to those keystations over all other system functions, e.g., writing to tape, printing, etc.

The Optimize System feature of the system provides a method for setting priorities for system use. This allows the user to establish the time to be spent processing batches or performing "background operations" such as:

- Batch Balancing,
- Communications,
- Edit Program Execution,
- Operator Statistics,
- Output,
- Printing,
- Searching,
- Sorting,
- Tape-Input.

This feature is activated by selecting (K) Optimize System from the System Operations List. Once selected, the following screen display appears:

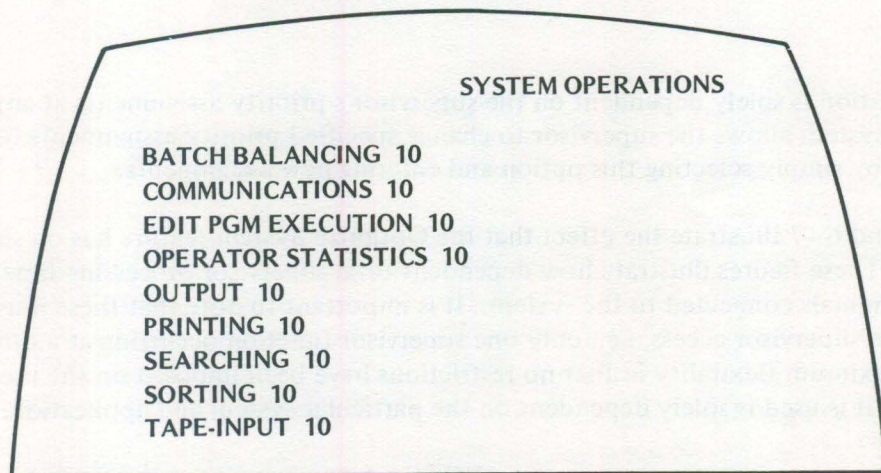

When the system is delivered, priority assignments for all operations listed are set to 10, as an established norm. The user may then enter a priority assignment from 1 to 99 beside the various operations, depending upon the application requirements at a particular time. Such operations as data entry may have fixed values. The user may decrease or increase time optimization by a factor of 10.

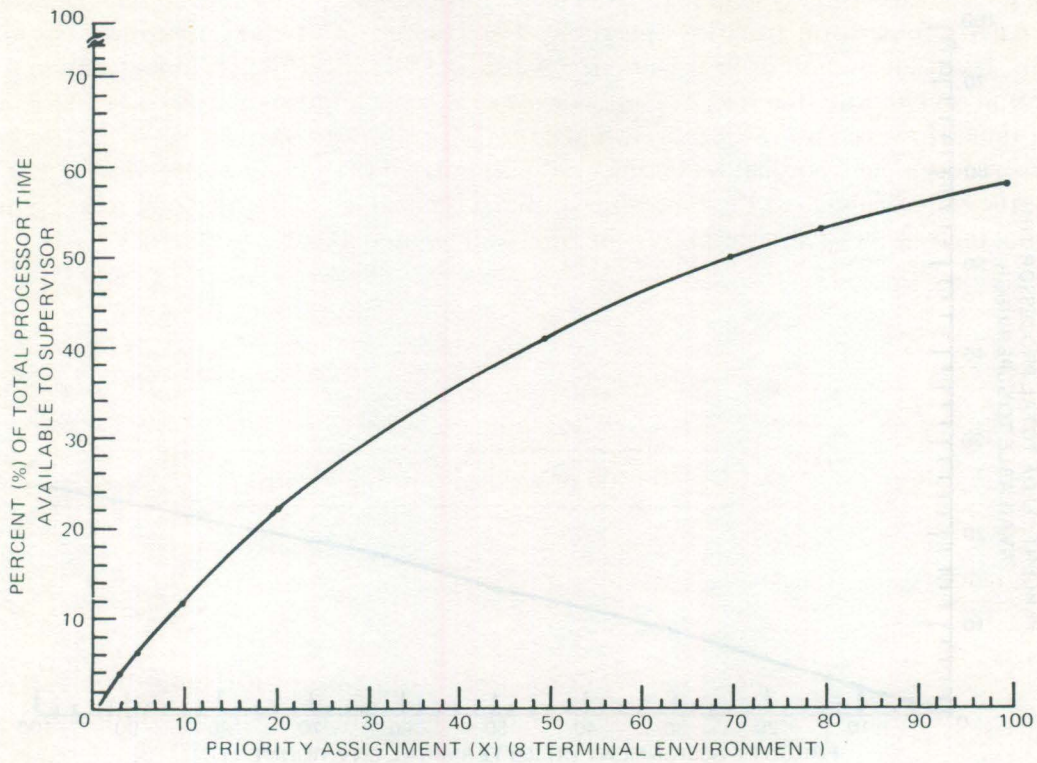

Calculation for Figure 6-6

PRIORITY ASSIGNMENT	AVAILABLE PROCESSOR
$1/10 = .1$	$.1/7.1 = 1\%$
$3/10 = .3$	$.3/7.3 = 4\%$
$5/10 = .5$	$.5/7.5 = 6\%$
$10/10 = 1$	$1/8 = 12\%$
$20/10 = 2$	$2/9 = 22\%$
$50/10 = 5$	$5/12 = 41\%$
$70/10 = 7$	$7/14 = 50\%$
$80/10 = 8$	$8/15 = 53\%$
$99/10 = 9.9$	$9.9/16.9 = 58\%$

Figure 6-6. Optimize System - 8 Terminal Environment

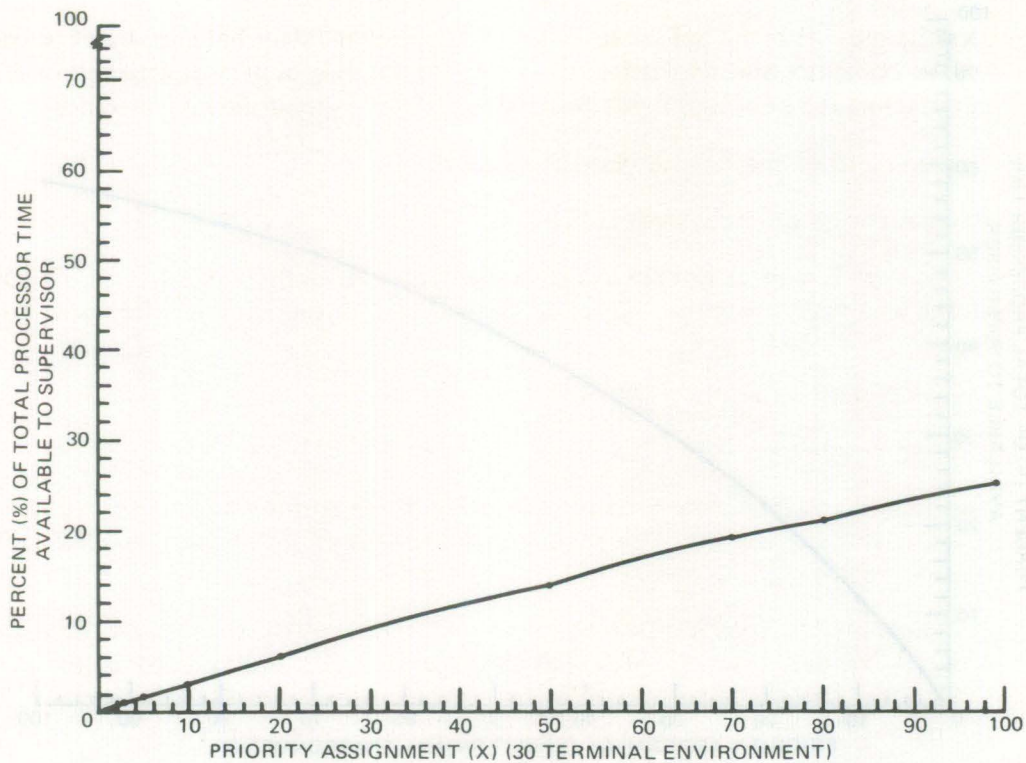

Calculation for Figure 6-7

PRIORITY ASSIGNMENT	AVAILABLE PROCESSOR
$1/10 = .1$	$.1/29.1 = 0\%$
$3/10 = .3$	$.3/29.3 = 1\%$
$5/10 = .5$	$.5/29.5 = 1\%$
$10/10 = 1$	$1/30 = 3\%$
$20/10 = 2$	$2/31 = 6\%$
$50/10 = 5$	$5/34 = 14\%$
$70/10 = 7$	$7/36 = 19\%$
$80/10 = 8$	$8/37 = 21\%$
$99/10 = 9.9$	$9.9/38.9 = 25\%$

Figure 6-7. Optimize System – 30 Terminal Environment

AUTOMATIC BATCH LOAD (ABL)

ABL provides the user with the ability to transfer disk resident data batches, batch statistics, operator ID's, and operator statistics from any 80 or 600 Series system to another 80 or 600 Series system utilizing the same software. This feature is used in the following instances:

- Upgrading from one software release to another,
- Batch recovery during system failure.

If an 80 Series system is malfunctioning to the extent that a Warm Start or System Save cannot be executed, the user may utilize the Automatic Batch Load procedure in an attempt to recover disk resident data.

General Operating Parameters

The following parameters are pertinent to the operation of the Automatic Batch Load feature of the system. Successful execution of this feature is dependent on a complete understanding of these parameters.

- Automatic Batch Load is a feature of software releases VIIC through DE-7. Although disk resident data batches, batch statistics, operator ID's, and operator statistics can be retrieved with the aid of the ABL feature from a system utilizing previous software, this data will only be accepted by a system utilizing software releases VIIC through DE-7.
- The program required to retrieve disk resident batches, batch statistics, operator ID's, and operator statistics is a stand-alone program which is not system resident. Therefore, a Master ABL Generator Tape must be Cold Started to activate the ABL feature.
- Once the Master ABL Generator Tape has been Cold Started and the Cold Start operation completed, a scratch tape must be mounted on the *same* tape drive for the purpose of retrieving all disk resident data batches, batch status, operator ID's, and operator statistics data. *Libraries are not retrieved by this operation.* This tape then becomes an ABL Data Tape.
- Loading an ABL Data Tape requires, as a minimum, that corresponding input formats be present in the system. However, it is also desirable to have corresponding Record End/Batch End Edit Routines and standard job formats within the system for the purpose of validating data as it is read back into the system via the ABL Data Tape. Therefore, it is *imperative* that users maintain an *up-to-date* Library Tape. ABL allows batches to be read from the ABL Data Tape as long as an input format exists to control entry. *Batches not corresponding to an existing input format are skipped.*
- During the Automatic Batch Load operation, batches are forced to conform to corresponding input formats. That is, if field and record lengths do not conform, error flags are inserted or extra characters or fields are truncated. If data is truncated, the data position prior to truncation will be filled with an error flag.

- ABL does *not* allow batches to read from the ABL Data Tape if those batches already reside in the system; rather, the names of duplicate batches will be entered in an ABL Log.
- If disk capacity reaches the 98% mark during an Automatic Batch Load operation, the remaining tape will be searched, and the names of batches and operator statistics remaining on tape will be listed in an ABL Log.
- If an ABL Log is generated during an Automatic Batch Load operation, the user may display the log on the DATA/TERMINAL and write the log to tape or printer, or exit. Once the user has selected the Exit option, the ABL Log is deleted, a Warm Start is initiated, and the system is returned to *normal operation*.
- If no ABL Log is generated during an Automatic Batch Load operation, a Warm Start is automatically executed at the completion of the read operation.
- The ABL Log is used to present messages pertinent to procedural problems during the Automatic Batch Load operation. ABL Log codes that are specific to a particular batch, edit, or standard job name are preceded by the batch name. Appendix C lists these codes and provides definitions. Figure 6–8 illustrates the format used to write or display the ABL Log.

Batch Name	ABL Log Code
BATCHNAME1	13
BATCHNAME2	
FMTNAME01	9
FMTNAME02	9
RENAME	11
BATCHNAME2	12

Figure 6–8. ABL Log Format

ABL Procedure

The following steps should be executed in the indicated order to perform an ABL. Whenever possible, terminate or at least interrupt active batches, process (output to tape or printer as desired), and delete all batches and statistics that are not needed on the system before doing an ABL.

NOTE

This procedure is based on the premise that all installations maintain current Library and Value Table Rescue Tapes. If a Library Tape is not read into the system during this procedure (refer to Step 9), the batches contained on the ABL Data Tape will not be read into the system. If a Value Table Rescue Tape is not read into the system during this procedure (refer to Step 10) and the Value Tables re-assigned, the last character of each Value Table field will be flagged with an error flag (#), as batches are read into the system.

1. Create two (2) System Saves.
2. Ensure that two (2) current Library Tapes are available. If not available, create two Library Tapes using the Write Libraries option of the Libraries List.
3. Ensure that two (2) Value Table Rescue Tapes are available. If not available, create two Value Table Rescue Tapes.

NOTE

The Nixdorf system does not support reading one-character records; therefore, all one-character Value Tables will have to be rekeyed (refer to Step 12) during this operation, unless the Value Table Batches are blocked during output.

4. Cold Start the Master ABL Generator Tape. This is accomplished in the same manner used to Cold Start a Master System Tape or System Save Tape.

WARNING

Prior to mounting the Master ABL Generator Tape, ensure that the tape reel does not contain a Write-Ring. If the tape reel contains a Write-Ring while mounted on the tape drive, the Master ABL Generator Tape will be destroyed, and the user will be unable to continue this operation.

5. Upon completion of the Cold Start operation (Step 4), all DATA/SCOPE Keystations will display the message "MOUNT TAPE ON SAME DRIVE AS MASTER." Once this message is displayed, remove the Master ABL Generator Tape from the tape drive and mount a scratch tape (containing a Write-Ring) on the same tape drive used to Cold Start the Master ABL Generator Tape.

NOTE

Ensure that the scratch tape will accommodate the volume of data on disk. If the system contains a dual disk and the disk status is high, a 1200 foot or even a 2400 foot reel of tape will, in all probability, be necessary. (Refer to discussion of multi-reel ABLs, Page 6-25.)

NOTE

Keystrokes will not be accepted by the system during this portion of the ABL operation. The messages "TAPE UNIT NOT READY" and "CHECK WRITE-RING" may be displayed on all keystations as appropriate.

6. Once the scratch tape is mounted on the tape drive and the tape unit is placed ON-LINE, the message "AUTO BATCH LOAD DATA TAPE GENERATION" is displayed at all DATA/TERMINAL Keystations and the process of writing all batches, batch statistics, operator ID's and operator statistics to tape is initiated.
7. When the message "COMPLETED" flashes on all keystations, rewind and remove the ABL Data Tape from the tape drive and remove the Write-Ring.
8. Cold Start the sysgen'ed software release Master System Tape. *Ensure that this tape does not contain a Write-Ring.*

WARNING

Do not attempt to manually initiate a Warm Start between Step 8 and Step 10 of the ABL procedure, or the procedure will have to be repeated from Step 8.

9. After the Master System Tape has been loaded, mount the Library Tape on the tape unit and read the tape onto disk via the Read All Libraries option of the Libraries List. *Ensure that this tape does not contain a Write-Ring.*
10. Upon completion of the Read All Libraries operation, remove the Library Tape and mount the tape containing Value Table Batches on the tape drive. *Ensure that this tape does not contain a Write-Ring.*
11. Read the Value Table Rescue Tape to disk (Batch I/O List).
12. If applicable, rekey any one character value tables.
13. Reassign value table reference numbers to corresponding batches (Batch Operations List).
14. Reinstate necessary numeric only exceptions (System Operations List).

NOTE

If this step is not accomplished, all fields containing numeric only exceptions will be flagged with an error flag.

15. Mount the ABL Data Tape on the tape drive. *Ensure that this tape does not contain a Write-Ring.*
16. Select (L) Auto Batch Load from the System Operations List.

17. Select the tape drive to be used to read the ABL Data Tape. Once the Tape drive is selected, the following message will appear: "HIT REL TO VALIDATE; OTHERWISE HIT HELP." When the REL Key is depressed, the system reads in the ABL Tape normally, i.e., it performs input, Record End, and Batch End checks on the data. If, however, the HELP Key is depressed, the data on the ABL Tape is simply read onto disk without user-specified validations, and active batches are "Interrupted." The user may then validate data at his own discretion. However, the data is always checked to see that it is correctly structured, i.e., it fits the input format structure and the linkage is correct.

NOTE

If the Read Without Validation option is chosen, i.e., the HELP Key is depressed, no input, Record End, or Batch End checks are performed on the data. All active batches will be "Interrupted."

18. Depress the REL Key if validation is required. Depress the HELP Key if the Read Without Validation option is desired (to increase the speed of ABL operation if the time element is critical). Once this choice has been made, the ABL Tape is read onto disk.

NOTE

During processing, each batch name and operator identification (ID) is displayed on the DATA/TERMINAL Keystation which initiated the ABL operation; all other keystations are locked out. Additionally, an incrementing record count is displayed beside each batch name, if the batch is being validated. The amount of time required to read the data contained on the ABL Data Tape is dependent on the system size (number of disks and the amount of data contained on disk) as well as the option selected. An ABL performed without validation will be read in the time required to read any tape using the Read With Standard Job Header feature.

NOTE

When the ABL is being validated, PAUSE, SHOW, and AUDIT verbs found in Editor programs will not be executed. WHEN VALIDATE, however, will be executed.

19. Once the ABL Data Tape has been read to disk, remove the tape from the tape drive.
20. If no errors are encountered by the system during the Automatic Batch Load Operation, the system automatically initiates a Warm Start. Upon completion of the Warm Start, the system is returned to *normal operation* and all keystations display the Operator HELP List.

21. If one or more errors are encountered by the system during the ABL operation, they are stored in an ABL Log. Access to this log is provided by the ABL Log Options List.

NOTE

The ABL Log is intended to list procedural problems that occur during an Automatic Batch Load operation. Errors encountered within specific batches during ABL, e.g., value table field flagged with error or numeric only exception field flagged with error, are not listed in the ABL Log. If it is desirable to obtain the names of batches containing such errors, the Write Batch Status feature of the Batch I/O Operations List should be utilized in conjunction with the Batch Status Protection feature of the 80 Series system upon completion of the ABL operation.

```
SYSTEM OPERATIONS
ABL LOG PRESENT
A WRITE ABL LOG
B EXIT
SELECTION 
```

This display is presented upon completion of the Automatic Batch Load operation on the DATA/TERMINAL which initiated the operation.

22. If it is desirable to write the ABL Log, select (A) WRITE ABL LOG and the desired output device (Tape unit 1-4, printer, or CRT). Once a device is selected, the system outputs the ABL Log. Upon completion, the ABL Log Options List is redisplayed, and the user may select another output device or exit. If (B) EXIT is selected, the ABL Log is deleted, a Warm Start is automatically initiated, and the system is returned to normal operation.

NOTE

The ABL operation retains the original status of all batches with the exception of active batches. Active batches will be given a status of "Interrupted." If a sort file exists prior to an ABL operation, ABL will delete that sort file.

FORMAT DISK

System disks are formatted to ensure that no data is written to any defective disk sectors. During the formatting process, the system attempts to write to every unallocated disk sector, testing for "bad" sectors. Any sectors that cannot be written to are locked out; the system does not attempt further use of them.

NOTE

After loading in a system save, FORMAT DISK should be performed.

The following steps are performed for the Format Disk option:

1. Select (M) FORMAT DISK from the System Operations Help List. The message "HIT REL TO PROCEED; OTHERWISE HIT HELP" is displayed. Depress the REL key.
2. All terminal keyboards are locked out, disk formatting begins and the message "FORMATTING IN PROGRESS" is displayed followed by the disk number and a running count of the disk cylinders that have been updated.
3. When formatting is completed, the message is cleared, and all terminals become operable. The System Operations Help List is displayed at the initiating terminal. The HELP key must be depressed at the other terminals to return to the Data Entry Help List.

NOTE

When bad sectors are located during a format operation, their address is logged in a bad sector map, and the sector is set up as if it had been allocated. When 60 bad sectors have been logged, the pack is considered unacceptable by the system; another disk pack should be used.

FORMAT DATA

System 3.11 is formatted to ensure that no data is written to any defective disk sectors. During the formatting process, the system attempts to write to every available disk sector and, for sectors for which the write attempt fails, the system does not attempt further use of those sectors.

NOTE

When formatting a volume with FORMAT, the volume should be high-level formatted.

The following steps are performed for the 3.5-inch disk option:

1. When the FORMAT command is entered, the system displays the message "HIT RETURN TO PROCEED, OTHERWISE HIT CTRL-C TO ABORT." When the RETURN key is pressed, the system displays the message "HIT RETURN TO PROCEED, OTHERWISE HIT CTRL-C TO ABORT."

2. All terminal keyboard characters are echoed on the terminal screen, and the message "FORMATTING IN PROGRESS" is displayed. The disk number and a progress indicator are displayed. Sectors that have been formatted are indicated by asterisks.

3. When formatting is complete, the message "FORMAT COMPLETE" is displayed. The system displays the message "FORMAT COMPLETE" and the message "HIT RETURN TO PROCEED, OTHERWISE HIT CTRL-C TO ABORT." When the RETURN key is pressed, the system displays the message "HIT RETURN TO PROCEED, OTHERWISE HIT CTRL-C TO ABORT."

NOTE

When disk sectors are located during a format operation, the system records the location of the defective sectors and the system does not attempt to write to those sectors. When the system is formatted, the system records the location of the defective sectors and the system does not attempt to write to those sectors.

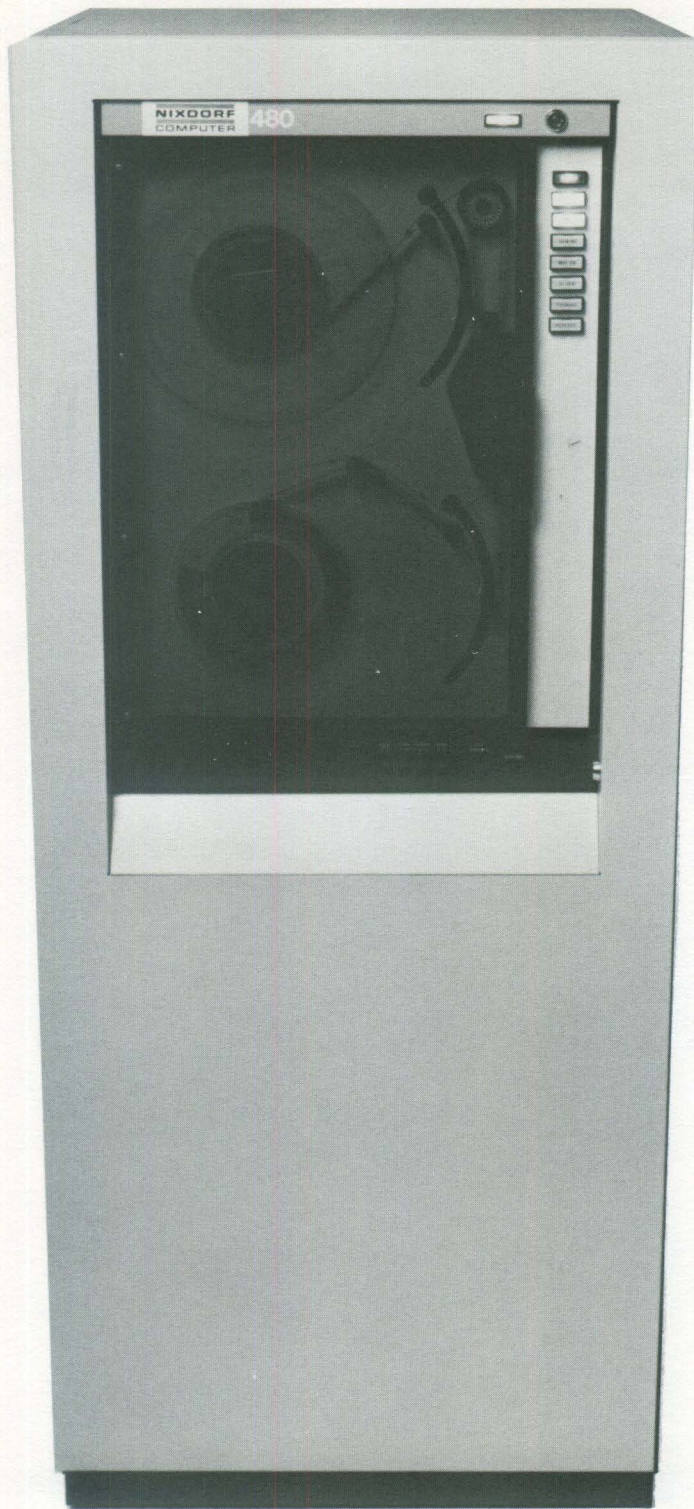

Figure 7-1. Nixdorf 80 Series System Central Control Group

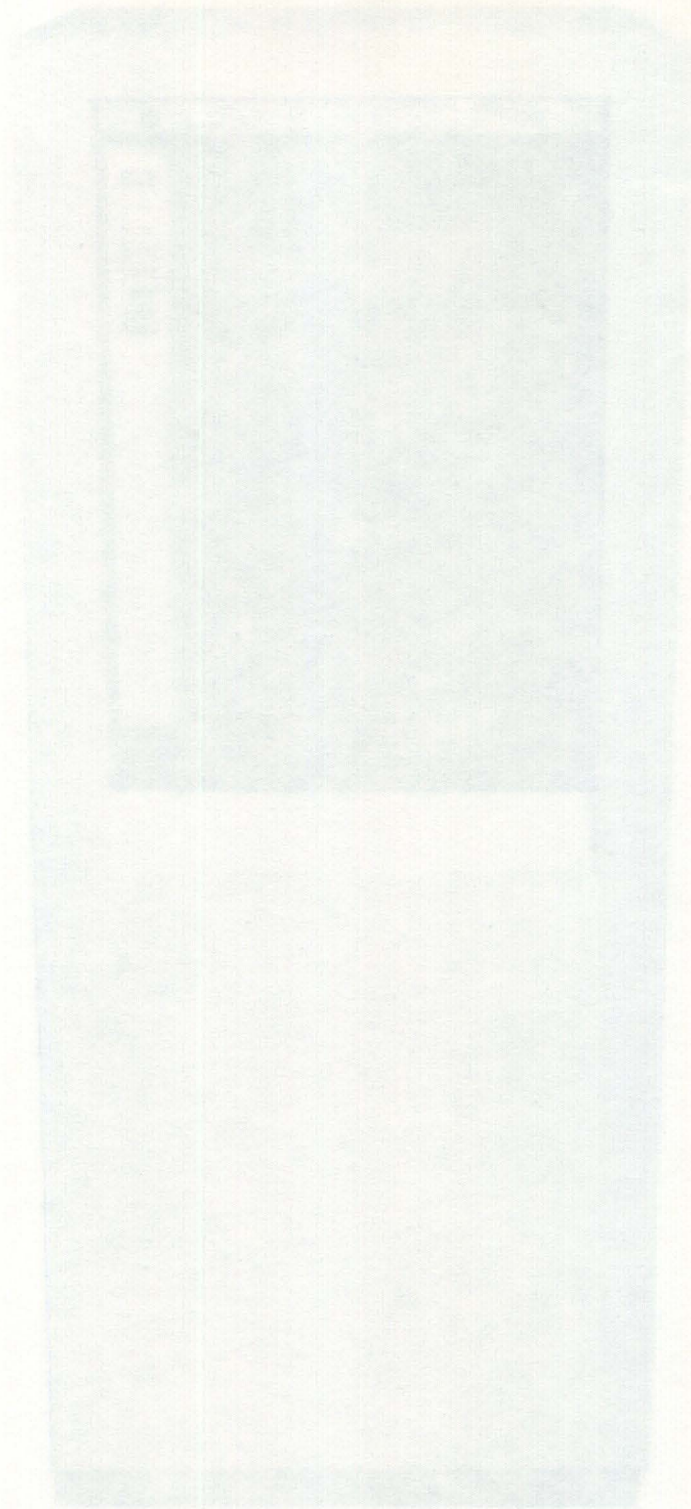

Figure 7-1. Model of the Central Group

SECTION 7 CENTRAL CONTROL GROUP

The 80 Series System Control Group combines a programmed processor, magnetic disk unit, and magnetic tape unit to control data entered from DATA/TERMINAL Keystations, remote entry, communications, or read into the system via magnetic tape or punched cards.

The entire control group is enclosed in a single cabinet. Figure 7-1 illustrates the Central Control Group cabinet. Figure 7-2 illustrates data flow through the 80 Series system. The following paragraphs detail the major units comprising the 80 Series System Central Control Group.

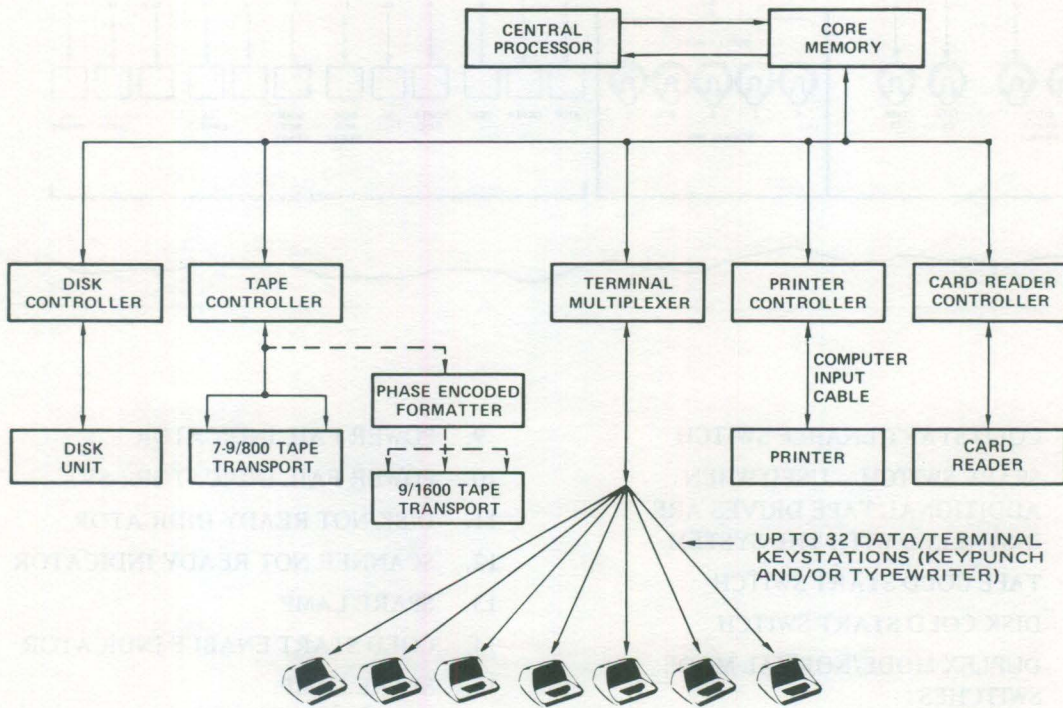

Figure 7-2. Data Flow Through the 80 Series System

SYSTEM CENTRAL PROCESSOR

A programmed processor is an integral part of the 80 Series system. The processor controls and validates data keyed by up to 32 DATA/TERMINAL Keystations. The processor is a highly reliable, versatile, 16-bit word minicomputer with 48K to 64K bytes of core memory and a memory cycle time of 1.2 microseconds. Standard hardware features include:

- Four accumulators;
- Two index registers;
- Direct memory access channel;
- Priority interrupt channel;
- Power failure protection and automatic restart.

In addition, the processor has been equipped with control switches and maintenance indicators illustrated in Figure 7-3 and discussed in the following paragraphs.*

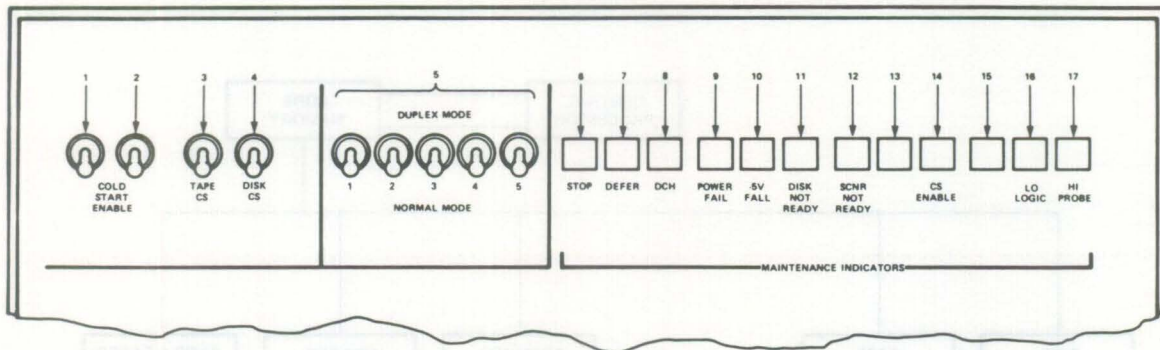

- | | |
|---|---------------------------------|
| 1. COLD START ENABLE SWITCH | 9. POWER FAIL INDICATOR |
| 2. SPARE SWITCH – USED WHEN ADDITIONAL TAPE DRIVES ARE INSTALLED WITH THE SYSTEM. | 10. POWER FAIL INDICATOR (-5V) |
| 3. TAPE COLD START SWITCH | 11. DISK NOT READY INDICATOR |
| 4. DISK COLD START SWITCH | 12. SCANNER NOT READY INDICATOR |
| 5. DUPLEX MODE/NORMAL MODE SWITCHES | 13. SPARE LAMP |
| 6. STOP INDICATOR | 14. COLD START ENABLE INDICATOR |
| 7. DEFER INDICATOR | 15. SPARE LAMP |
| 8. DATA CHANNEL INDICATOR (DCH) | 16. LO LOGIC INDICATOR |
| | 17. HI PROBE INDICATOR |

Figure 7-3. Central Processor Control Panel

*Control switches for the newer Central Processor (mfg. after June, 1977) are discussed in Appendix D.

Control Switches

The system processor is provided with a series of control switches which allow the supervisor to perform the following operations:

- Automatically load system programs from tape into memory and disk;
- Automatically load system programs from disk into memory;

The control switches and their functions are discussed below:

- **COLD START ENABLE Switch** – Enables the supervisor to load an 80 Series Master System tape (e.g., a new program release) or a System Save or ABL tape as well as perform Warm Starts.
- **TAPE COLD START (CS) Switch** – The TAPE CS Switch works in conjunction with the COLD START ENABLE Switch. Loading a Master System, System Save, or ABL tape requires manual activation of these switches.
- **DISK COLD START (CS) Switch** – The DISK CS Switch works in conjunction with the COLD START ENABLE Switch. Performing a Warm Start to refresh the software in memory requires manual activation of these switches.

Maintenance Indicators

The central processor also provides several indicators for maintenance of the system. These indicators and the symptoms which they indicate when ON are invaluable tools to Field Service personnel in the event of system failure. The function of each maintenance indicator is discussed below:

NOTE

Any lamp that continues to glow steadily and brightly may indicate a malfunction or an error condition.

- **STOP Indicator** – When illuminated (bright light), this lamp indicates a hardware problem; perform a Warm Start – if unsuccessful, notify Nixdorf Field Service personnel.
- **DEFER Indicator** – A dimly lit, blinking light indicates that the next processor cycle will be used to fetch an address word in an indirectly addressed memory reference instruction. This lamp usually glows dimly; should it become bright, it indicates a malfunction – perform a Warm Start and notify Nixdorf Field Service personnel.
- **DATA CHANNEL Indicator** – A dimly lit, blinking light indicates data transfers between external devices and the processor.
- **POWER FAIL Indicator** – A brightly lit lamp indicates that there is a malfunction in the computer power supplies. Turn off the system and call Nixdorf Field Service Representative.
- **POWER FAIL (-5V)** – A brightly lit lamp indicates that the -5V supply is absent. Terminals become inoperative (data entry stopped); turn off system; notify Nixdorf Field Service personnel.

NOTE

It is sometimes possible to correct a POWER FAIL condition by momentarily switching the system off and then on again.

- **DISK NOT READY Indicator** – A brightly lit lamp indicates that the disk has not cycled-up (usually occurs when the central control group power is turned ON). Typically, this lamp will go out after the disk has operated for approximately one minute. If this indicator remains lit, notify Nixdorf Field Service personnel.

NOTE

This indicator may flash intermittently during a Warm Start.

- **SCANNER NOT READY Indicator** – During normal operation this indicator is always dimly lit. A brightly lit lamp indicates that there is a possible hardware problem. Should the light fail to go out and the system is locked up, perform a Warm Start. If this fails, notify Nixdorf Field Service personnel.

NOTE

This indicator will be brightly lit during part of a Warm Start.

- **COLD START ENABLE Indicator** – This lamp acts as a reminder to place the COLD START ENABLE Switch in the down position after a Tape or Disk Cold Start.
- **LOGIC LEVEL Indicators (HI/LO)** – These lamps are used by maintenance personnel. During normal system operation, these indicators will switch ON and OFF occasionally, and are of no significance to the system supervisor.

Console Controls

In addition to the control switches and maintenance indicators provided for the supervisor, the central processor contains a power switch, maintenance switches and operational indicators on the lower half of the processor panel. It is important to note that the maintenance switches on the lower half of the processor panel are used primarily for maintenance purposes and, as such, the *supervisor should rarely, if ever, have occasion to handle these switches*. The exception to this general rule is when activating the ECHO feature, discussed in Section 6.

The key-operated POWER Switch controls the ac (primary power) input to the processor power supply. In the OFF position, the ac power is absent from the power supply. In the ON position, ac power is supplied to the processor. In the LOCK position ac power is also supplied to the processor; however, all console controls are disabled. The LOCK position allows the processor to operate without interference from occasional or accidental console control manipulation. For this reason, the POWER Switch should always be placed in the LOCK position. The POWER Switch key can only be removed from the console when the key is in the LOCK position. This key should be removed from the console during normal processing and placed in the storage area of the front door or some other area suggested by the Field Service Representative.

NOTE

Automatic Restart is possible only if the key is in the LOCK position. Power fail recovery will not be possible if the key is in the ON position.

CENTRAL DISK

The 80 Series system provides two types of disk units. The first is a random-access, fixed disk device used by the central processor for immediate data storage of up to 9.6 megabytes (refer to Table 7-1). The second type of central disk, available with System 480 only, is a random-access, removable pack disk unit used by the central processor for immediate data storage of 33 megabytes (refer to Table 7-1). Refer to Section 6 for a discussion of 33 Mbyte Disk operation.

TABLE 7-1. DISK CHARACTERISTICS

Characteristic	Cartridge Disk Units			Disk Pack Unit
	2.4 million	4.8 million	9.6 million	
Capacity (bytes)	2.4 million	4.8 million	9.6 million	33 million
Cylinders per unit	202	404	404	404
Tracks per cylinder	2	2	4	5
Sectors per track	24	24	24	64
Bytes per sector	256	256	256	256
Seek time (milliseconds):				
Track-to-track	15	15	15	7
Average	67	67	67	30
Maximum	135	135	135	55
Transfer rate (bytes/second)	195,000	195,000	195,000	1.2 million
Average latency	20	20	20	8.3

All Nixdorf disk units feature:

- Dynamic allocation of disk space.
- Read after write check.
- Cyclic redundancy check character (hardware and software).
- Complete record address stored within each sector to insure correct disk access.

Central disk controls are set by Nixdorf Field Service personnel during system installation.

MAGNETIC TAPE UNITS

Nixdorf provides the ability to select a tape unit to meet specific requirements. One or more of the following tape units may be specified when ordering a system:

- 9-channel – 800 bpi, with 8½-inch reel (System 280),
- 9-channel – 1600 bpi, with 8½-inch reel (System 280),
- 7-channel – 556/800 bpi, with 10½-inch reel (System 380/480),
- 9-channel – 800 bpi, with 10½-inch reel (System 380/480),
- 9-channel – 1600 bpi, with 10½-inch reel (System 380/480).

The tape drives provide read/write operation as well as Beginning Of Tape (BOT) and End Of Tape (EOT) sensors and have a reel capability of up to 2400 feet of tape.

The front panel tape unit configuration, available with the 80 Series system, is illustrated in Figure 7-4. In addition to an expanded tape capability, the system is capable of simultaneously maintaining up to four tape units of varying characteristics.

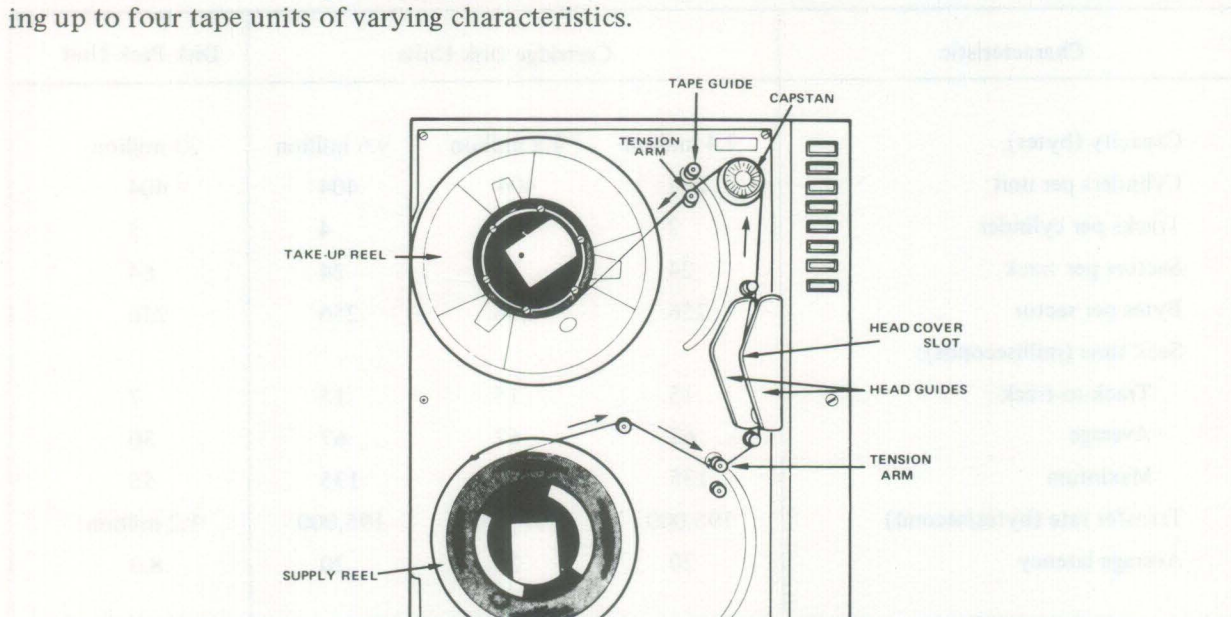

Figure 7-4. Nixdorf Standard Tape Drive

Tape Drive Operation

The following control switches and indicators are provided on the Tape Unit:

- POWER Lamp – The POWER Lamp, a status indicator, is illuminated whenever the system is in operation and power is applied to the tape unit. It also functions as an ON/OFF switch for the tape unit only. The tape unit should never be powered off with a tape loaded.

- **LOAD Switch** – This momentary contact switch, when depressed, causes the tape unit to advance the tape to the BOT marker. If the tape is already loaded and tensioned, depressing this switch has no effect.
- **ON-LINE Switch** – The ON-LINE Switch/Indicator, when depressed, places the tape unit on-line with the 80 Series system processor. Depression of the RESET Switch causes the tape unit to go off-line.
- **REWIND Switch** – This momentary contact switch, when depressed, causes the tape to be rewound to the BOT marker (operational only if tape drive is not in On-Line Mode). If tape is already positioned at BOT, a depression of the REWIND switch will cause the tape to unload from the take-up reel.
- **FILE PROTECT Lamp** – The FILE PROTECT Lamp, a status indicator, is illuminated whenever a Write-Ring is not installed on the supply reel. Under this condition, the tape unit can not write to tape. Once a Write-Ring is installed on the supply reel, the FILE PROTECT Lamp goes out.
- **REVERSE/DENSITY Switch** – On a nine-track unit, this switch is a reverse switch which causes tape to be rewound at 25 IPS rather than 150 IPS. The reversing process is stopped by depressing the RESET switch.

On a seven-track unit, this switch controls recording density. If lighted, recording is at 800 BPI; if not lighted, recording is 556 BPI. Depressing the DENSITY switch changes the recording density.
- **FORWARD Switch** – This switch causes the tape to be advanced at 25 IPS. The forwarding process is stopped by depressing the RESET switch.
- **RESET Switch** – This momentary contact switch, when depressed, resets tape circuits, causes tape motion to stop and the tape unit to go off-line.

The following procedure is used to load a Tape Unit:

1. Mount the tape (supply) reel on the left hand (or top) hub and put the lock-on hub in place. If the tape is to be written on, *insure that a Write-Ring is secured to the tape reel.* When reading a tape, the Write-Ring should be removed to prevent an accidental write-to-tape operation.
2. Thread the tape as illustrated on the face. While threading the tape, remove tension from the tape by manually unwinding (clockwise) the supply reel, as tape is pulled through the threading path.
3. Wind the tape around the take-up reel. When the tape is secured on the take-up reel, depress **the LOAD Switch.** The transport will automatically advance the tape to BOT. When BOT is reached, the tape will stop **with the ON-LINE switch lighted.**
4. Close the dust cover on the tape unit; the tape unit is now ready for use.

The following procedure is used to unload a Tape Unit:

1. Depress the RESET Switch. If not at BOT, depress the REWIND Switch.
2. When tape is at BOT, depress the REWIND Switch again.
3. Remove the tape reel from the hub.

CONTROL GROUP SPECIFICATIONS

Table 7-2 lists major specifications and environmental requirements of the system Central Control Group:

TABLE 7-2. CENTRAL CONTROL GROUP SPECIFICATIONS

CHARACTERISTIC	SPECIFICATION
TEMPERATURE (AMBIENT, OPERATING)	60° to 80°F
HUMIDITY (RELATIVE, OPERATING)	30% to 80%
ELECTRICAL POWER REQUIREMENTS	117 Vac \pm 10%, 60Hz
HEAT DISSIPATION	6400 BTU-per-hour
CLEARANCE FOR OBSTRUCTION (INSTALLATION)	2' each side, 3' rear door, 4' front door
DIMENSIONS	26" wide, 27" deep, 52" high
WEIGHT (APPROXIMATE)	600 pounds

OPERATIONAL REQUIREMENTS

The following operational requirements have been established by Nixdorf to insure that system operation is not disrupted by unfavorable environmental or physical requirements:

Temperature

An ambient temperature range of between 60° to 80°F must be maintained for optimum stated system performance. No widening or relaxation of this range is permitted.

Humidity

An ambient relative humidity between 30 and 80% must be met. This is largely dictated by requirements of magnetic tape and paper.

Altitude

Maximum altitudes should be 10,000 feet above sea level. An altitude above this level affects the efficiency of forced-air cooling.

Dust and Dirt

Nixdorf equipment was designed under the assumption that it will be used in a controlled environment. Excessive dust and dirt, suspended or settled, may cause failure. This condition can result in overheating, poor connections and sticky key switches. A system which operates in a dirty/dusty environment will require more preventative maintenance than one running in a clean environment. A preventative maintenance schedule will be set up by ENTREX Field Service personnel during system installation; the supervisor should insure compliance with this schedule.

Access

Adequate area for maintenance must be maintained at the front and back of the Central Control Group and DATA/TERMINALS.

SYSTEM MAINTENANCE

Nixdorf system maintenance is relatively simple from the supervisor viewpoint, the essential element being a clean, dust free environment. The following steps should be followed to attain the goal of reliable, accurate operations.

Central Control Group Cabinet

Cabinet doors should be closed at all times. The cabinet should be dusted (cleaned) each day.

Tape Units

Tape units should be dusted each day, and the read/write head should be cleaned with a lint free cloth and 91% isopropyl alcohol or suitable tape head cleaner. The plexiglass window in front of the tape unit should be closed at all times, unless loading or removing a tape from the tape unit. When followed, these steps will reduce the possibility of input errors caused by a dirty tape unit.

DATA/TERMINAL Keystation

The DATA/TERMINAL cover should be dusted daily; when required, the screen may be cleaned with commercial glass cleaner. Precautions should be taken to insure that fluids or foods of any type are not inadvertently introduced into the keyboard. To further this end, Nixdorf urges supervisors to prohibit personnel from bringing food or beverages in the vicinity of the DATA/TERMINAL.

Peripheral Devices

Peripheral devices should be cared for in the same manner as the major elements of the 80 Series system. All peripherals should be cleaned daily. Additionally, certain adjustments may be required on a periodic basis. Section 8 discusses the peripheral devices authorized for use with the 80 Series system. All adjustments required by these peripherals are discussed in Section 8.

System Tapes

Nixdorf system tapes contain Nixdorf software programs. Each system installation should maintain three distinct types of system tapes:

- **Master System Tape** – This tape is generated by Nixdorf and *must never be written on by the user*. The Master tape should be loaded (Cold Start Procedures) only when there is no usable data on disk. Loading a Master tape overlays all data and libraries on disk. Normally, a Master tape is loaded only when an ABL is performed.
- **System Save Tapes** – System Save tapes are generated by the supervisor at regular intervals for backup purposes. These *Saves* provide a complete copy of core memory and disk and should be taken at regular intervals such as work breaks and lunch hours. System Saves as well as all other tapes must be carefully labeled with the date (month, day, year) as well as the hour of *Save*. If it is necessary to load a System Save (Cold Start Procedures), the most recent version is used. Loading a System Save overlays all data and libraries on disk.
- **Master Library Tapes** – Master Library tapes should be generated by the supervisor whenever programs or formats have been changed. These tapes provide a complete copy of all library formats with the exception of operator statistics.
- **Scratch Tapes** – To insure system efficiency, new tapes should be available for use with the system. At least two tapes will be required to store format libraries; eight tapes should be used for system save rotation; additional tapes should be available for data manipulation. An ample supply of tape labels should also be available.

Another important consideration in the success of the 80 Series system is the quality of tape used for reading and writing data. Nixdorf urges the use of new, tested tapes. Although complete error checking precautions, including read-after-write checks, are executed by the system, input errors may be introduced by the use of old or dirty tapes.

Tape Cold Starts

The Tape Cold Start feature of the 80 Series system allows the supervisor to read System Save tapes or Master System tapes. Tape cold starts are manually performed with the aid of the control switches provided on the central processor (Figure 7-3). To load System Save tapes, use the following procedure:

1. Mount the reel containing the System Save or Master System tape to be loaded.

NOTE

If a System Save or Master System tape is to be loaded, insure that no usable data is on the disk. Loading a System Save or Master System tape overlays all present data and libraries on disk.

2. Depress the LOAD Switch on the tape drive unit. The tape is positioned at the BOT marker.

3. The On-Line Switch will illuminate, indicating the tape is on-line to the processor.
4. Place the COLD START ENABLE (Central Processor) Switch in the UP position.
5. Momentarily hold the TAPE CS (Central Processor) Switch in the UP position.
6. Once tape loading is initiated, place the COLD START ENABLE Switch in the DOWN position.

When the tape stops loading, it rewinds automatically and may be removed. If the cold start tape does not load properly, clean the read/write heads and reload the tape. If this action fails to correct the problem, load a backup System Save tape. If this fails, notify local Nixdorf Customer Support or Field Engineering personnel.

Warm Starts

The Warm Start feature provides the ability to execute diagnostic programs designed to recover from system problems and refresh memory. No usable data is lost when a *warms* is executed. A warm start should be executed in the event of keystation lockout or system failure. This action will usually correct an existing difficulty and allow continued system operation.

Prior to executing a warm start to correct a terminal lockout situation, a System Save should be taken. The System Save will provide a "snapshot" of the difficulty and insure that no data is lost if a hardware malfunction is discovered during the *warms*.

NOTE

If a System Save is taken prior to a warm start, and the system is a multiple disk system, ensure that a large tape reel (2400 feet) is used for the save.

If a hardware problem is discovered during a warm start, system operation can not be resumed without loading a System Save. Data in the system that is not on the System Save tape will be lost. Therefore, the save should be as recent as possible.

A warm start should *never* be executed when any dynamic operation is in progress; e.g., while deleting batches, batch totalling, seeking error flags, or writing to tape/printer. If the system is operating, all operators should terminate their batches.

To execute a warm start, use the following procedure:

1. Place the COLD START ENABLE Switch (Central Processor) in the UP position.
2. Momentarily hold the DISK CS Switch (Central Processor) in the UP position.

3. Place the COLD START ENABLE Switch in the DOWN position.
4. Once the COLD START ENABLE Switch is placed in the DOWN position, the system initiates the warm start and displays the message "WARMS IN PROGRESS" and a running count of the number of minutes being used by the "warms".

The amount of time required to execute a warm start is directly related to the number of open batches and the number of operators who have been keying data; in general, the time required is dependent on the size of the system. Warm start completion is indicated by the DATA/TERMINAL Keystations; i.e., when the warms is completed, the keystations become operational.

If a warms is not successful (the counter stops and all terminals are not brought to the Operator HELP List), the supervisor should attempt to execute another warms; however, the supervisor must insure that the first warms has stopped. *In no instance should the warm starts be nested; i.e., do not attempt to execute a warm start when one is already in progress.*

If attempts to correct a system problem via the second warm start are unsuccessful, the supervisor should contact the local Nixdorf Customer Support or Field Service personnel.

NOTE

A warms erases all operator entered ID's. These ID's should be re-entered before continuing data entry operations.

WARNING

In general, a warm start should *never* be executed when any dynamic operation is in progress.

Notice if a Warms is performed after beginning a batch delete operation, but *before* completing the operation, those batches being deleted cannot be accessed (i.e., the batch names cannot be displayed). However, the disk space allotted to those batches will not be released, either in whole or in part. The only method of recovering that disk space is to perform an ABL.

SECTION 8 PERIPHERAL DEVICES

Nixdorf offers the following card reader and printers for use with the 80 Series system:

- Model 510 Serial Printer (Figure 8-1) – A high-speed serial printer with a 165 character-per-second operating speed and a 132 character-per-line capability.
- Model 533 Line Printer (Figure 8-2) – A highly reliable line printer with a 300 line-per-minute operating speed and a 132 character-per-line capability.
- Model 536 Line Printer (Figure 8-2) – A high-speed line printer with a 600 line-per-minute operating speed and a 132 character-per-line capability.
- Model 539 Line Printer (Figure 8-3) – A high-speed line printer with a 900 line-per-minute operating speed and a 132 character-per-line capability.



Figure 8-1. Model 510 Serial Printer

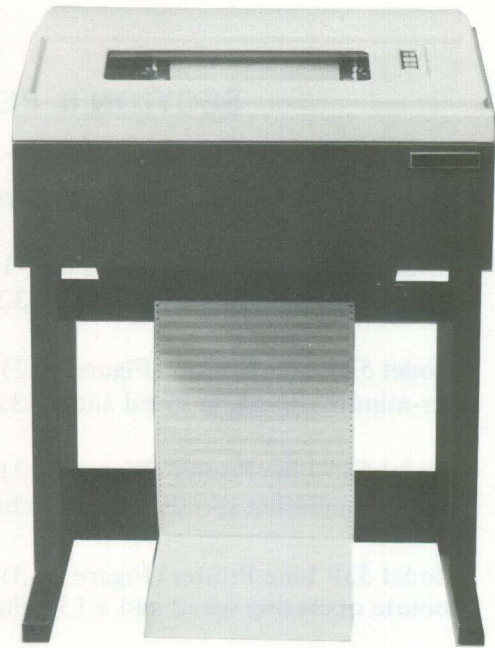

Figure 8-2. Model 533/536 Line Printer

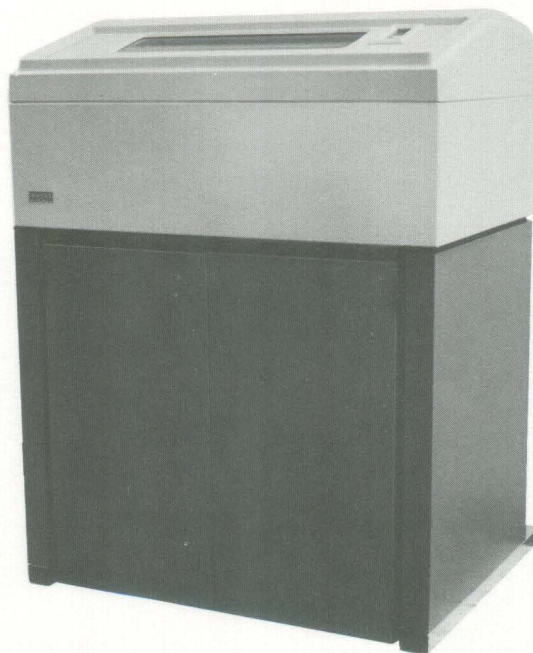

Figure 8-3. Model 539 Line Printer

MODEL 510 SERIAL PRINTER

Model 510 is a high-speed serial printer which uses a 5 x 7 dot matrix for character generation. The unit prints at a rate of 165 characters per second with an average operating speed of 132 cps including print head return. The printer is capable of printing 132 characters per line, and containing paper widths varying from 4 to 14½ inches. The printer uses sprocket-fed paper and prints six lines to the inch with ten characters per inch, horizontally. No special paper is required; the printer can produce an original and four copies. Figure 8-4 illustrates the Model 510 Serial Printer. The following paragraphs highlight the printer's operational characteristics.

Printing Method

Printing is accomplished by selectively firing seven print solenoids attached to print wires. As the print head moves from left to right across the print line, these wires construct the graphic characters via dots. The seven print wires are arranged in a column in the printing head; dots are formed as the ends of the wires press the ink ribbon against the paper. Solenoids can fire up to five times for any one character. Figure 8-5 illustrates the solenoid assembly, print head and character matrix.

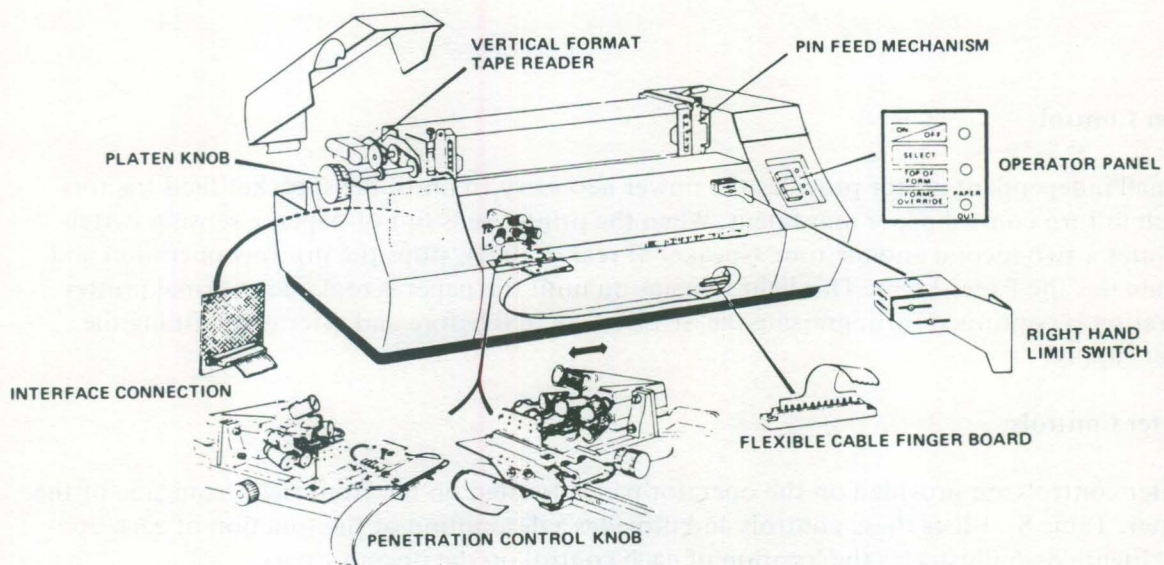

Figure 8-4. Model 510 Serial Printer

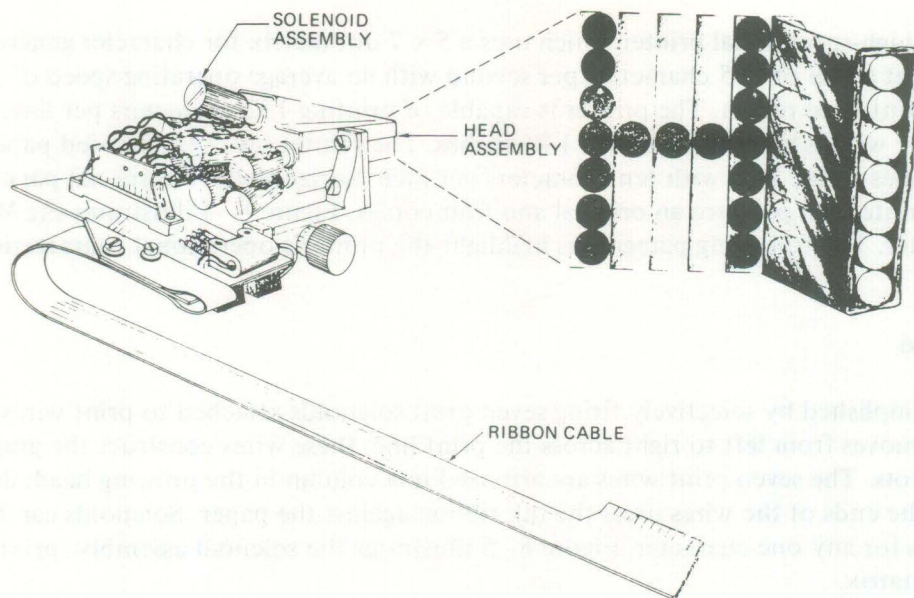

Figure 8-5. Solenoid Assembly, Print Head and Character Matrix

Paper Control

A small independent motor provides the power necessary to move the sprocket feed tractors which in turn control paper movement. When the printer runs out of paper, a sensing switch activates a two-second audible tone (speaker at rear of unit), stops the printing operation and illuminates the Paper Light. This light remains on until the paper is replaced. Normal printer operation is continued by depressing the SELECT Switch before and after replenishing the paper supply.

Printer Controls

Printer controls are provided on the operator panel, located on the front right hand side of the printer. Table 8-1 lists these controls and provides a description of the function of each control. Figure 8-6 illustrates the location of each control on the operator panel.

TABLE 8-1. PRINTER CONTROLS

CONTROL	FUNCTION
POWER ON/OFF SWITCH	Alternate depression of the POWER ON/OFF Switch turns the printer ON and OFF. When in the ON position, the indicator is illuminated.
SELECT SWITCH	Depression of the SELECT Switch allows the printer to receive data from the system.
TOP OF FORM SWITCH	Depression of the TOP OF FORM Switch advances the printer to the top of the next form. However, adjustment of the Rapid Advance Lever is a prerequisite.
FORMS OVERRIDE SWITCH	When the printer is out of paper (PAPER OUT Indicator is ON), the FORMS OVERRIDE Switch can be depressed, allowing the printer to complete the form currently being printed. This switch must be pressed and held while the form is being completed.
HARDWARE ALARM	The HARDWARE ALARM rings to indicate that the printer has tried to print in the left or right-hand margin. If this occurs, contact Nixdorf Field Engineering personnel.
PAPER OUT	When lit, PAPER OUT indicates that the printer is out of paper.

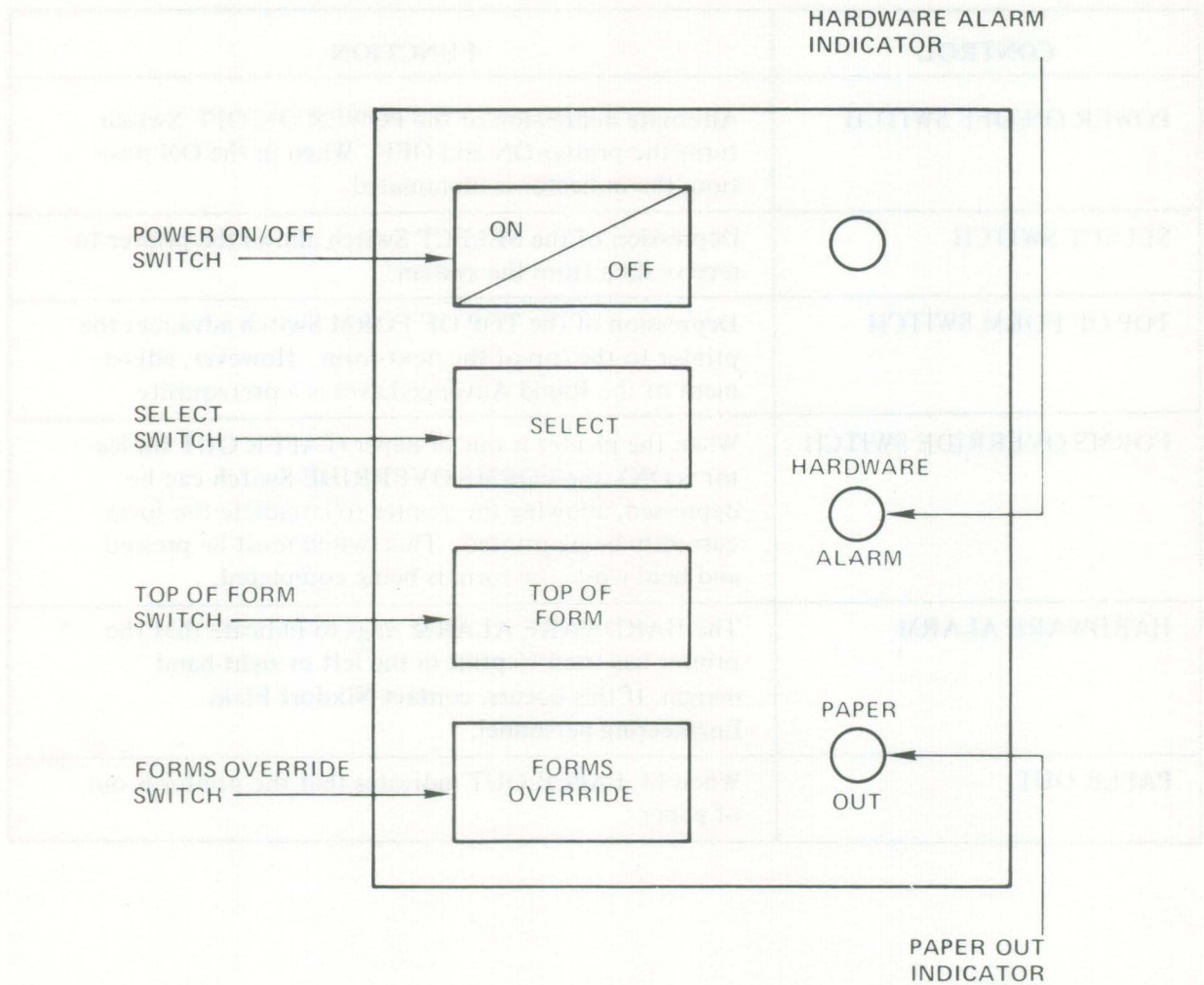

Figure 8-6. Operator Control Panel

Manual Controls

In addition to printer controls, the Model 510 Serial Printer provides several controls for inserting and adjusting forms. Table 8-2 lists these controls and provides a description of the function of each control. Figure 8-7 illustrates their location on the printer.

TABLE 8-2. MANUAL CONTROLS

CONTROL	FUNCTION
PAPER ADVANCE KNOB	Rotating the PAPER ADVANCE Knob advances the paper in a forward direction. Paper can be moved in the reverse direction by depressing the lever on the inside of the PAPER ADVANCE Knob and turning the knob forward.
RAPID ADVANCE LEVER	<p>Pulling the RAPID ADVANCE Lever forward causes the paper to be moved forward.</p> <p>This lever is used to advance the printer to top of the form each time the paper is changed. After manually setting to top of the form, the TOP OF FORM Switch may be depressed to advance the printer to the top of the next form.</p>
PENETRATION CONTROL LOCKING KNOB	The PENETRATION CONTROL LOCKING Knob must be loosened to set the FORM THICKNESS Control, described below.
FORM THICKNESS CONTROL	<p>FORM THICKNESS Control is set according to thickness of the paper and the number of copies to be printed. The higher settings move the Print Head Assembly away from the platten.</p> <p>This control should be adjusted to allow for the following conditions:</p> <ul style="list-style-type: none"> ● A very thick form thus avoiding jamming, ● A very thin form thus avoiding embossing, ● A new ribbon thus avoiding smudging.

Ribbon Changing

The Model 510 Serial Printer uses a one-inch fabric ribbon on a standard three-inch spool. Figure 8-8 illustrates the ribbon path. The following procedures are used to change a ribbon.

1. Raise the front and side panels of the printer.
2. Loosen the PENETRATION CONTROL LOCKING Knob so that the FORM THICKNESS Control can be adjusted. Set the FORM THICKNESS Control to 5.
3. Remove the left and right spool covers as well as the caps from the Ribbon Reversing Guides.

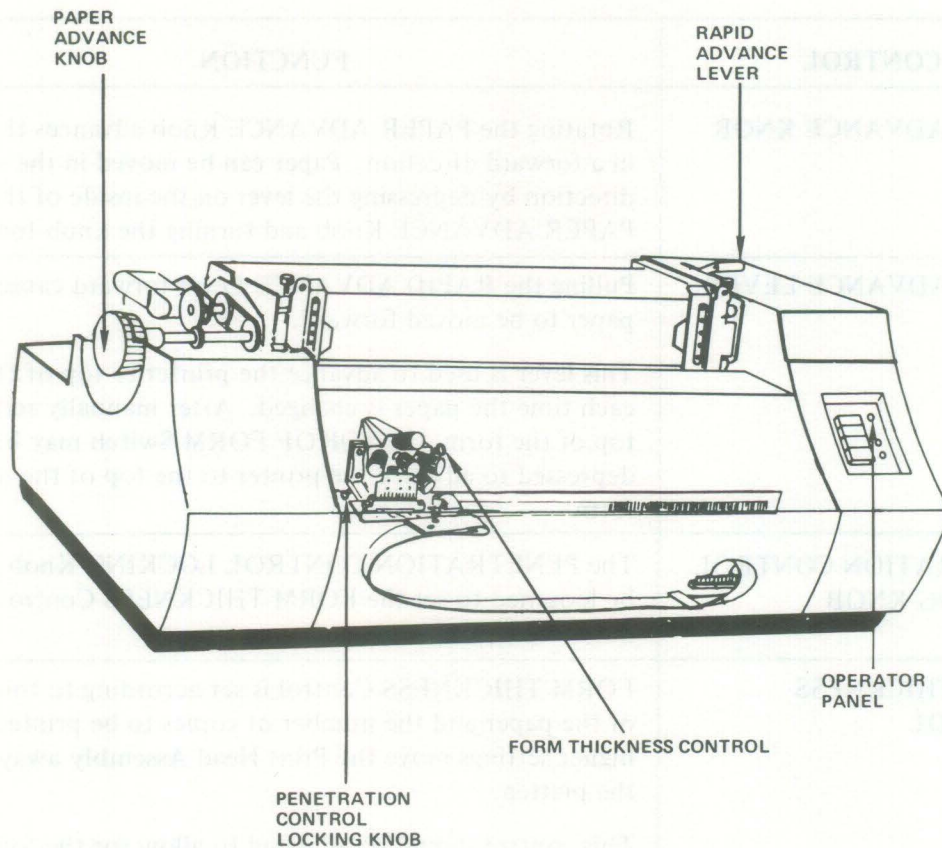

Figure 8-7. Manual Controls

4. Swing the Ribbon Tension Arms away from the spools and remove the spools from the printer.
5. Place new spools on the empty axles.
6. Guide the ribbon through the Reversing Guides, Idlers, and the Ribbon Guides, as illustrated by Figure 8-8 .
7. Replace the caps on the Ribbon Reversing Guides as well as the covers on the left and right spools.
8. Adjust the Form Thickness Control and tighten the Penetration Control Locking Knob.
9. Close front and side panels. During operation, all covers must be closed and secured.

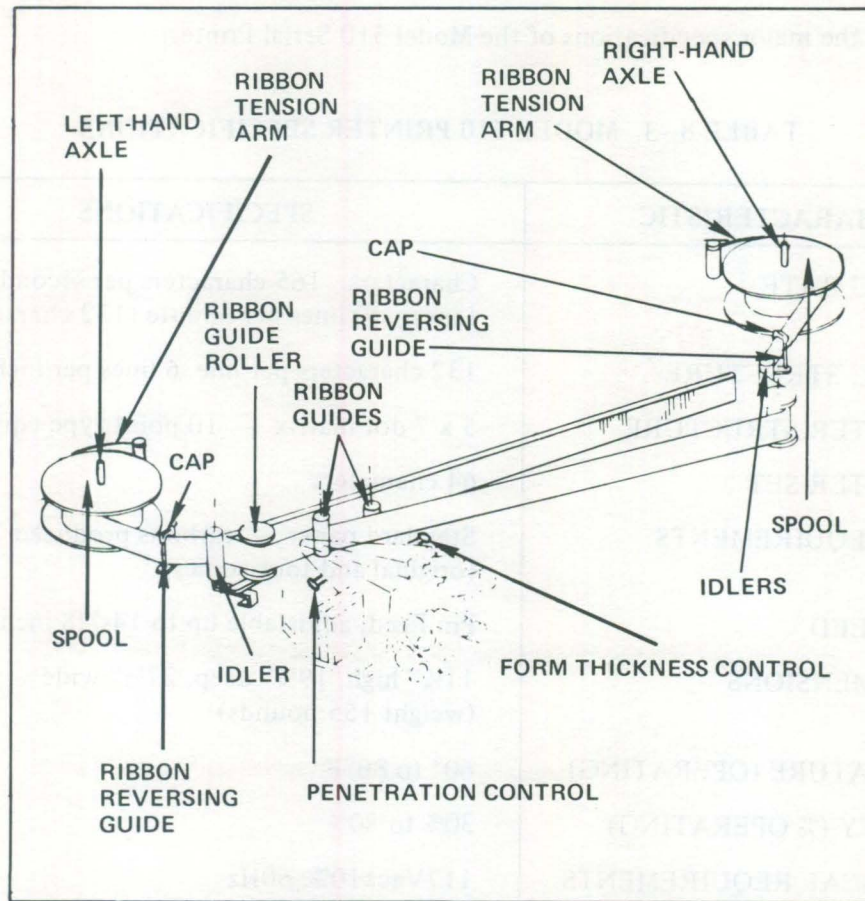

Figure 8-8. Ribbon Path (Serial Printer)

Forms

The printer uses continuous form paper folded on cross perforations. Paper margins must have feedholes located $\frac{1}{4}$ -inch from edge. Multiple copies can be made using carbon paper between sheets, carbonized paper or carbonless paper. Forms selected for use with the Model 510 Serial Printer must conform to the following specifications:

- Form width must not be less than 4 inches or greater than $14\frac{1}{2}$ inches.
- Forms must not exceed 11 inches in length. If longer forms are to be used, a hardware adjustment is necessary.
- Forms must not consist of more than five parts; i.e., one original and four copies.
- If the forms consist of more than one part, copies cannot be stapled together or glued at the margins.

Printer Characteristics

Table 8-3 lists the major specifications of the Model 510 Serial Printer.

TABLE 8-3. MODEL 510 PRINTER SPECIFICATIONS

CHARACTERISTIC	SPECIFICATIONS
PRINTING RATE	Characters: 165 characters per second Lines: 60 lines per minute (132 characters)
PRINTING STRUCTURE	132 characters per line, 6 lines per inch
CHARACTER STRUCTURE	5 x 7 dot matrix – 10 point type equivalent
CHARACTER SET	64 characters
PAPER REQUIREMENTS	Standard paper – carbons produced (original and four copies)
PAPER FEED	Pin Feed, adjustable up to 14-7/8 inch wide forms
UNIT DIMENSIONS	11¼" high, 19¼" deep, 27½" wide (weight 155 pounds)
TEMPERATURE (OPERATING)	60° to 80°F
HUMIDITY (% OPERATING)	30% to 80%
ELECTRICAL REQUIREMENTS	117Vac±10%, 60Hz

MODEL 533 LINE PRINTER

The Model 533 Line Printer (Figure 8-2) is a highly reliable, compact line printer with an operating speed of 300 lines per minute and a 132 character-per-line capacity. The printer is enclosed in a sound-deadening cabinet with an integral stand. It may be connected directly to the Central Control Group to perform all system printing functions.

Most parts, modules and assemblies of the Model 533 Line Printer operate in the same manner as those of the Model 539 Line Printer discussed in detail in later paragraphs.

The following are the major specifications of the Model 533 Line Printer that differ from the Model 539 Line Printer specifications:

- Printing Rate – 300 lines per minute,
- Weight – 340 pounds.

MODEL 536 LINE PRINTER

The Model 536 Line Printer is a high-speed printer that is used with an "80" Series Central Control Group. It uses the rotating drum impact method of printing to produce copy at 600 lines per minute. The unit is mounted in a sound-deadening cabinet with a hinged canopy for easy access to the printer mechanism, and is illustrated in Figure 8-2. Major features of the Model 536 Line Printer include:

- 600 line-per-minute printing rate;
- 64-character print set;
- 6 or 8 lines per inch, switch selected;
- Up to 5 copies plus original;
- 136 characters per line;
- Vertical Formatting Unit (VFU).

MODEL 539 LINE PRINTER

The Model 539 Line Printer (Figure 8-3) is another high speed printer that may be used with a 600 Series Central Control Group. The Model 539 is a heavy-duty impact printer using a rotating character drum to produce copy at 900 lines per minute. This printer is designed for high reliability and simplified maintenance. The major features of the Model 539 Line Printer are:

- A 900 line per minute printing rate,
- A 64 character printer set,
- A clutchless paper feed mechanism,
- 6 or 8 lines per inch,
- Up to 5 copies plus original,
- 132 characters per line,
- A Vertical Formatting Unit (VFU),
- Active Ribbon Control,
- A Static Eliminator, and
- Paper collection and stacking.

Printing Method

The printer mechanism consists of two subassemblies: a stationary mainframe and a drum gate which holds the print drum and ribbon. The drum gate pivots away from the mainframe to allow paper loading or ribbon changing. Figure 8-9 illustrates the printer with cover and drum gate open.

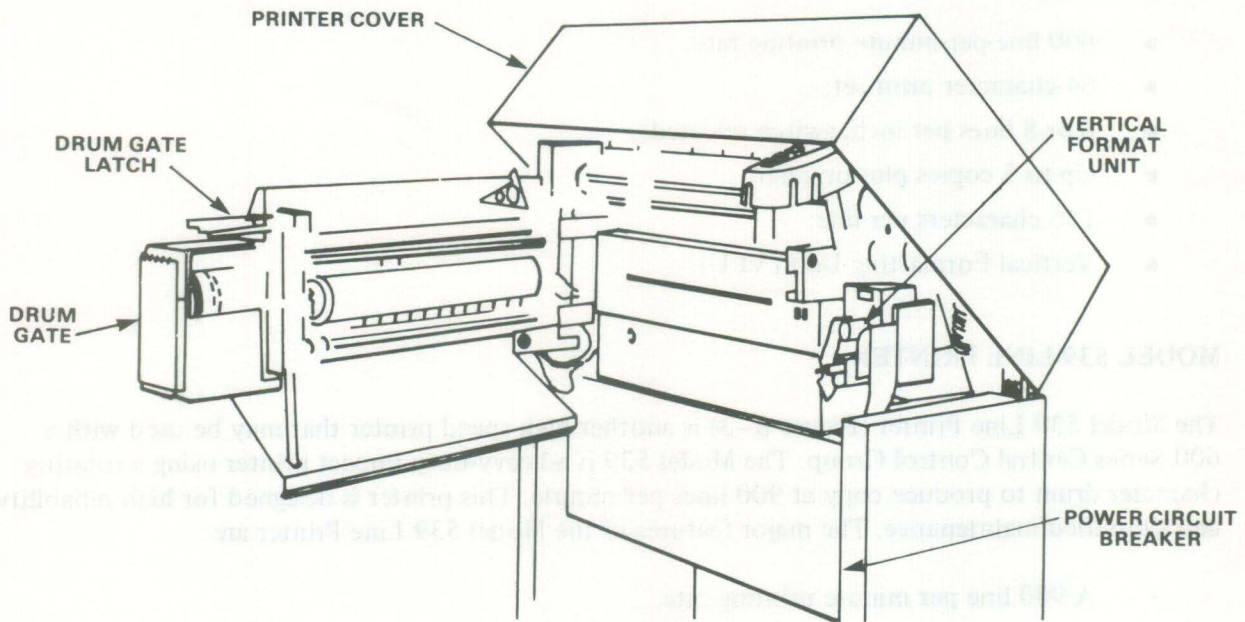

Figure 8-9. Model 533/536/539 Line Printer (Cabinet Open)

Printing is accomplished when the mainframe print hammers press the paper and ribbon against the characters on the spinning print drum. The drum has 132 circular character columns, one for each print position; each column contains a full 64-character set. Each print hammer is activated when the proper characters on the spinning print drum reach the printing position. Upon completion of one print line, the paper feed tractors advance the paper to the next line, and the printer ribbon is advanced.

Printer Controls

Printer controls are divided into three major types:

- Operator panel controls and indicators,
- Fault indicators,
- Operational adjustments.

Operator Panel Controls and Indicators – The operator panel on the upper right corner of the printer contains a set of lamps and switches used to control and monitor printer operation. The operator panel is shown in Figure 8–10 and the functions of the individual controls and indicators are described in Table 8–4.

Two additional controls, the POWER Circuit Breaker located in the lower right-hand region of the unit, below the printer cover (Figure 8–9), and the Vertical Formatting Unit TAPE START Switch (Figure 8–9), are also discussed in Table 8–4.

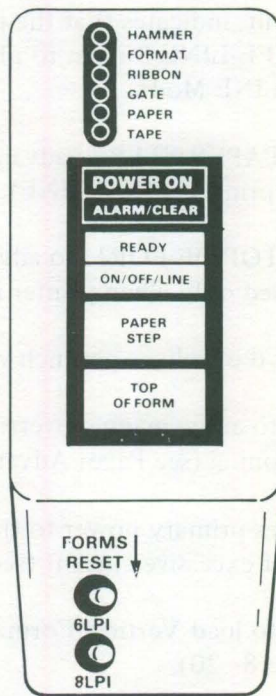

Figure 8–10. Operator Control Panel

TABLE 8-4. MODEL 533/536 PRINTER CONTROLS AND INDICATORS

CONTROL/INDICATOR	FUNCTION
POWER ON	Indicates that printer power is turned ON.
ALARM	Indicates that a fault condition exists or that the PRINT INHIBIT Switch is ON. Press the ALARM Button to reset the FAULT Indicator once fault conditions have been corrected.
READY	When lit, indicates that the printer is ready for on-line operation.
ON/OFF-LINE	When lit, indicates that the printer is ON-LINE. Press the ON/OFF-LINE Button to place the printer in ON-LINE or OFF-LINE Mode.
PAPER STEP	Press PAPER STEP to advance paper one line (enabled only when printer is OFF-LINE).
TOP-OF-FORM	Press TOP-OF-FORM to advance paper to top of form (enabled only when printer is OFF-LINE).
6/8 LINES PER INCH	Select 6 or 8 lines-per-inch vertical spacing.
FORMS RESET	Press to allow manual override of paper feed system for form positioning (see Paper Advance adjustments, Table 8-6).
POWER	Applies primary power to the printer and breaks circuit in case of excessive current (see Figure 8-9).
TAPE START	Used to load Vertical Format Unit control tapes (see Figure 8-20).

Fault Indicators – A set of six light-emitting diodes are located on the upper portion of the operator panel (Figure 8-10), and serve as fault indicators for specific printer problems. The control panel ALARM Indicator lights simultaneously with any fault indicator. Once corrective action is performed, both indicators are extinguished by pressing the ALARM Switch. Table 8-5 describes the function of each fault indicator. Note that the printer cover must be raised to view these indicators.

TABLE 8-5. MODEL 533/536 FAULT INDICATORS

INDICATOR	FUNCTION
HAMMER	Indicates that a print hammer is not operating properly. The occurrence of a hammer fault causes the printer to go off-line without completing the print operation in progress.
FORMAT	Indicates that the number of line feeds executed does not correspond to the number of line feed commands. The occurrence of a format fault causes the printer to go OFF-LINE upon completion of the print operation in progress. The paper must be repositioned and the FORMS RESET Switch pressed before pressing the ALARM Switch.
RIBBON	Indicates that the ribbon is not advancing properly, due to a failure to reverse, a snag, or a motor problem. The occurrence of a ribbon fault causes the printer to go OFF-LINE upon completion of the printing operation in progress.
GATE	Indicates that the drum gate is not latched. The printer ceases operating when the drum gate is opened with power on.
PAPER	Indicates torn paper, out-of-paper, or paper-runaway condition. The occurrence of a paper fault causes the printer to go OFF-LINE upon completion of the printing operation in progress.
TAPE	Indicates a parity error in the Vertical Formatting Unit (VFU) memory, or that a tape channel command was received for which no hole has been punched. The occurrence of a tape fault causes the printer to go OFF-LINE upon completion of the printing operation. The VFU tape must be reloaded to correct the fault before pressing the ALARM Switch.

Operational Adjustments – Several adjustments are necessary to ensure proper and efficient operation of the line printers. The location of adjustment controls are indicated in Figure 8-11 and their functions are discussed in Table 8-6.

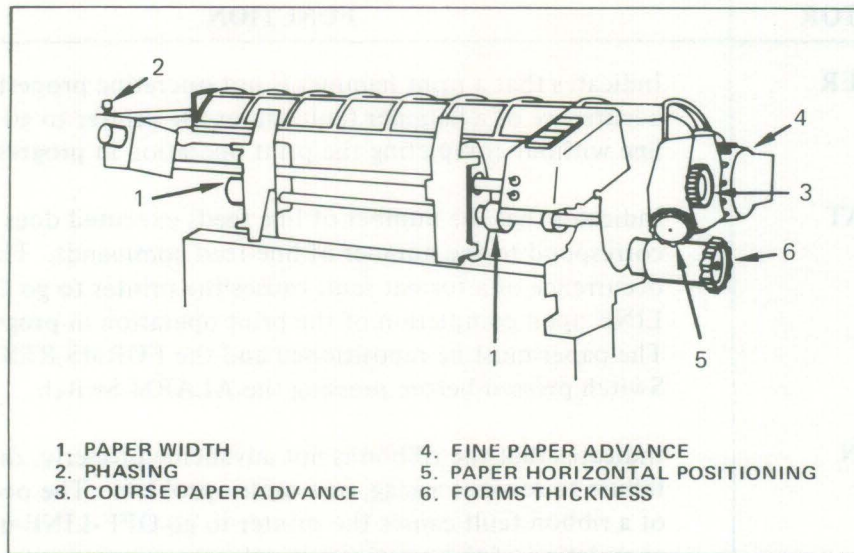

Figure 8-11. Operational Adjustments

TABLE 8-6. MODEL 533/536 OPERATIONAL ADJUSTMENTS

CONTROL	FUNCTION
PAPER WIDTH	Allows the forms tractors to be moved independently to adjust for varying paper widths or for coarse horizontal paper positioning.
PHASING CONTROL	Varies ink density to maintain top to bottom character consistency.
COARSE PAPER ADVANCE	Vertically positions paper at predetermined increments. The FORMS RESET Switch must be DOWN when making Coarse Paper Advance adjustments.
FINE PAPER ADVANCE	Provides fine vertical positioning of paper between the predetermined increment range of the Coarse Paper Advance. The FORMS RESET Switch must be UP when making Fine Paper Advance adjustments.
PAPER HORIZONTAL POSITIONING	Provides fine horizontal paper adjustment by allowing movement of both tractors simultaneously.
FORMS THICKNESS	Compensates for different paper thickness when installing paper.

Print Quality – Four manual controls, explained in Table 8–8, may require adjusting to improve print quality:

- Forms Thickness Knobs,
- Phasing Control,
- Coarse Paper Advance,
- Fine Paper Advance.

Because of the numerous types of paper that may be used, there are no firm rules for setting these knobs, however, the knobs should be adjusted for:

- Very thick forms to avoid jamming,
- Very thin forms to avoid embossing,
- Fresh ribbons to avoid smudging.

On-Line Start-Up Procedure

The following procedure is used to prepare the printer for system-controlled operation:

1. Ensure that paper and ribbon are properly installed.
2. Set the Power Circuit Breaker ON. After five seconds the POWER ON/OFF and READY Indicators should light.
3. Press and release the ON/OFF-LINE Switch to ready the printer for on-line operation.
4. Observe printer operation, and make FINE PAPER ADVANCE adjustments as required to obtain desired print line positioning.
5. Adjust the PHASING Control as required to obtain uniform character (ink) density. Rotate the PHASING Knob slowly to obtain proper density.

Shutdown Procedure

The following shutdown procedure is used to turn the printer off:

1. Press and release the ON/OFF-LINE Switch to put the printer in the off-line condition. Observe that the indicator light goes out once the current print line is printed.
2. Set the Power Circuit Breaker (located below the print station) OFF. Observe that the POWER ON/OFF and READY Indicators are extinguished.

Paper Loading

Perform the following steps to load paper:

1. Ensure that the Power Circuit Breaker is ON. Press and release the TOP-OF-FORM Switch on the Operator control panel; the tractors will automatically advance to the top-of-form position.

2. Lift the printer cover, pull the drum gate latch forward, and swing it to the fully open position (Figure 8-9). *Ensure that the print drum has stopped rotating before proceeding.*
3. Open the tractor spring-loaded pressure plates (Figure 8-12).

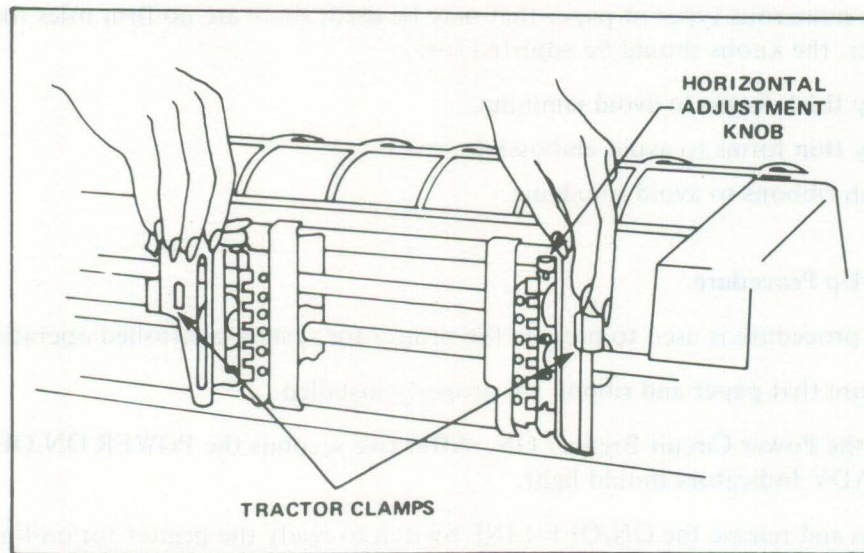

Figure 8-12. Tractor Pressure Plates

4. Place paper in the tractors and close the pressure plates. Loosen both Paper-Width Adjustment Controls and move both tractors laterally, if necessary, to adjust for correct paper width; tighten the Paper-Width Adjustment Controls.
5. Align the paper perforations at the top-of-form position by depressing the FORMS RESET Switch on the operator control panel while rotating the COARSE PAPER ADVANCE Adjustment Knob.
 - The Top-of-Form Index may be used when installing paper to allow the first line of print to appear on any of the first nine lines after the paper perforation. In Figure 8-13, paper is installed with a two-line top-of-form spacing and printing will start on the third line.
 - Paper may be installed using the HORIZONTAL PAPER POSITIONING Control to allow the first print-column to be indented up to two inches from the paper's edge. In Figure 8-13 paper is installed with the first print column indented approximately one inch.
6. Close and latch the drum gate. Close the printer cover.

NOTE

Use the FINE PAPER ADVANCE Adjustment Knob to correct any minor misalignment observed during printing operations. First adjustment is made with the FORMS RESET Switch in the UP position, drum gate closed, and the cover raised. Use the PAPER HORIZONTAL POSITIONING Adjustment Knob to correct any minor horizontal misalignment during printing operations.

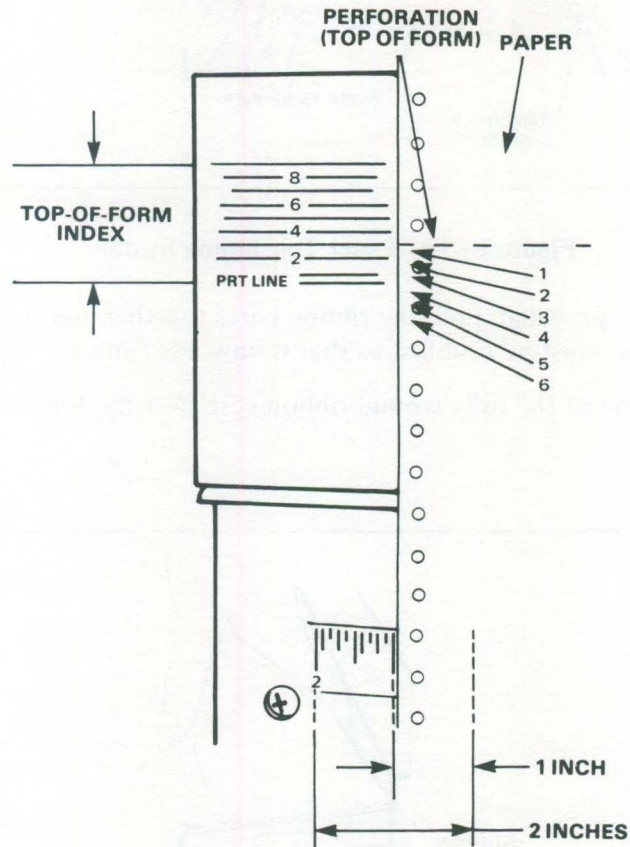

Figure 8-13. Paper Alignment

Ribbon Removal and Installation

The following steps are performed to remove and load the printing ribbon:

1. Lift the print cover, pull the drum gate latch forward, and swing the drum gate fully open. *Ensure that the print drum has stopped rotating before proceeding.*
2. Holding the paper tension with one hand (Figure 8-14), pull the paper tensioner plunger knob, and remove the paper tensioner from the drum gate.

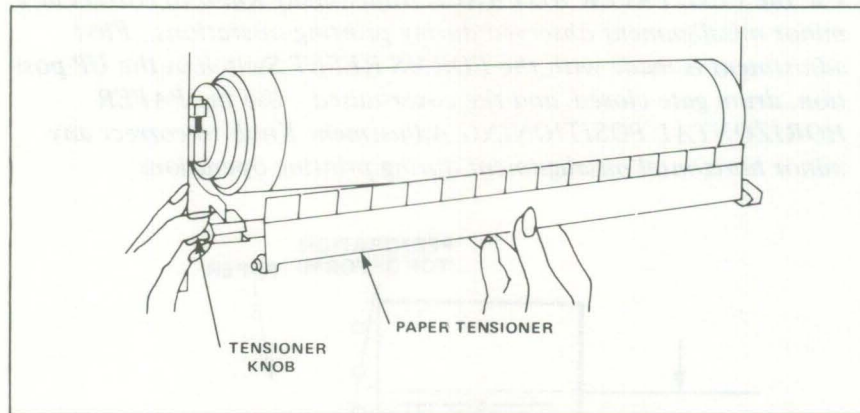

Figure 8-14. Paper Tensioning System

3. Using the gloves provided, hold the ribbon cores together and remove the ribbon from its box. The ribbon must be installed so that it unwinds from the top of the ribbon core.
4. Place the left end of the fully wound ribbon core over the top floating ribbon holder (Figure 8-15).

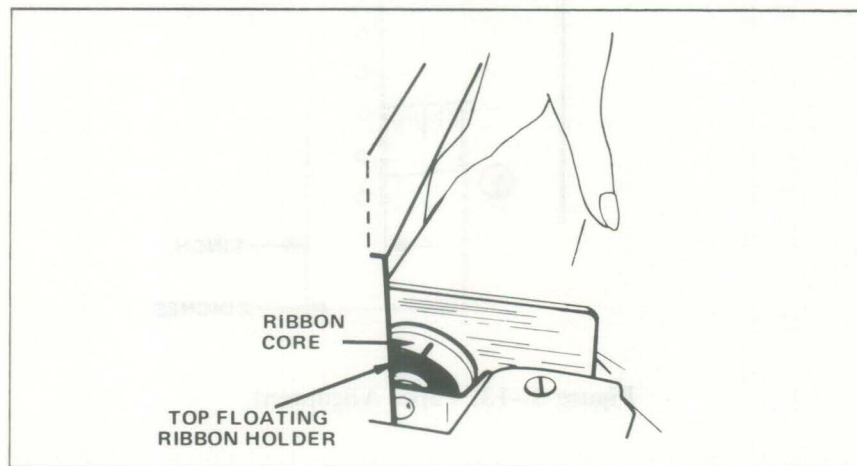

Figure 8-15. Upper Left Ribbon Core Installation

5. Push the ribbon core against the floating ribbon holder spring and place the opposite ribbon core end over the upper fixed ribbon holder. Ensure that the holder guide pin slips into its slot on the core end (Figure 8-16).

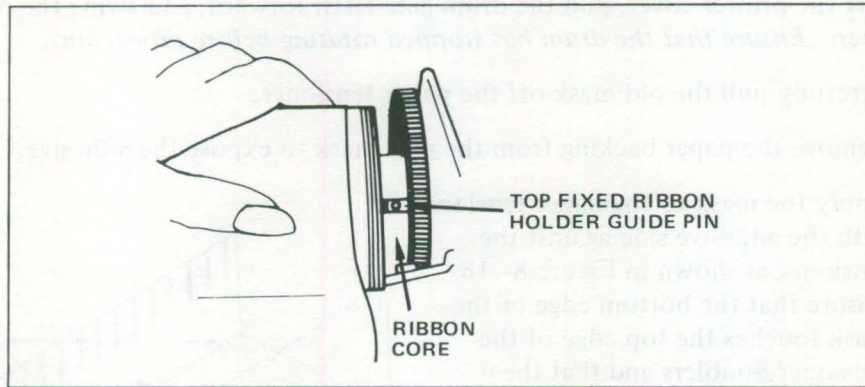

Figure 8-16. Upper Right Ribbon Core Installation

6. Unwind the second ribbon core and thread it down over the character drum and ribbon guide bars. Once in position, install the lower ribbon cores on the bottom ribbon holders as outlined in Steps 4 and 5.
7. Install the paper tensioner by inserting the paper tensioner block into position. Push the tensioner against the tensioner knob indexing slot while pulling the knob to allow slot engagement. Once the tensioner is engaged, release the knob. Figure 8-17 shows the ribbon and tensioner completely installed.

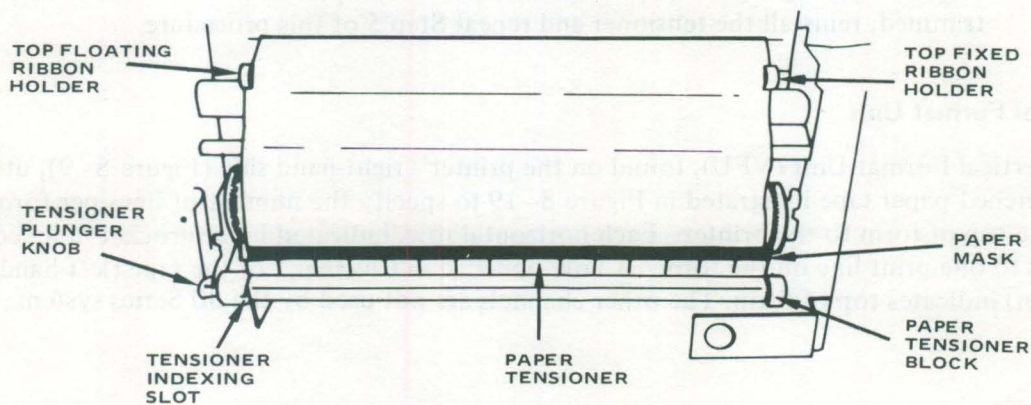

Figure 8-17. Drum Gate with Ribbon Installed

Paper Mask Installation

A plastic paper mask is provided on the printer paper tensioner (Figure 8-17) to prevent contact between the ribbon and paper prior to printing. During normal operation, the mask may require replacing as described in the following steps:

1. Lift the printer cover, pull the drum gate latch forward, and swing the drum gate fully open. *Ensure that the drum has stopped rotating before proceeding.*
2. Carefully pull the old mask off the paper tensioner.
3. Remove the paper backing from the new mask to expose the adhesive.
4. Apply the mask to the paper tensioner with the adhesive side against the tensioner as shown in Figure 8-18. Ensure that the bottom edge of the mask touches the top edge of the tensioner doublers and that the top edge of the mask is about 1/8 inch below the print station.

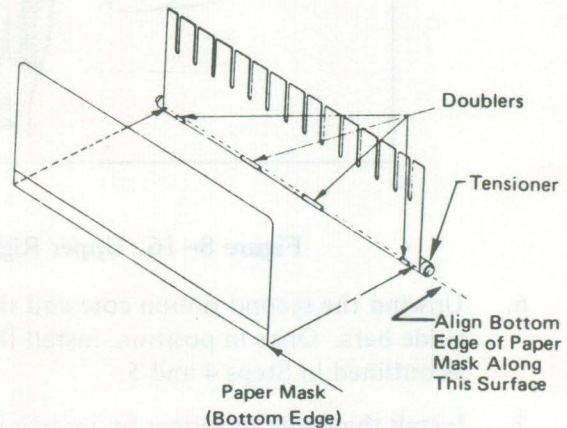

Figure 8-18. Paper Mask Installation

5. Close the drum gate. With the power on and the drum rotating, check for any excessive or unusual noise which may be generated if the top edge of the newly installed paper mask is too close to the center line of the print drum. If noise occurs, perform Step 6.
6. Turn off the printer and, *after the print drum has stopped rotating*, open the drum gate. Remove the paper tensioner as outlined in the Ribbon Loading and Removal section and trim the top edge of the paper mask slightly with a pair of scissors. Once the mask is trimmed, reinstall the tensioner and repeat Step 5 of this procedure.

Vertical Format Unit

The Vertical Format Unit (VFU), found on the printer's right-hand side (Figure 8-9), utilizes the punched paper tape illustrated in Figure 8-19 to specify the number of lines per form and indicate top-of-form to the printer. Each horizontal row, indicated by a sprocket hole, corresponds to one print line on the form. A hole punched in Channel 1 of the tape (left-hand vertical column) indicates top-of-form. The other channels are not used by the 80 Series system.

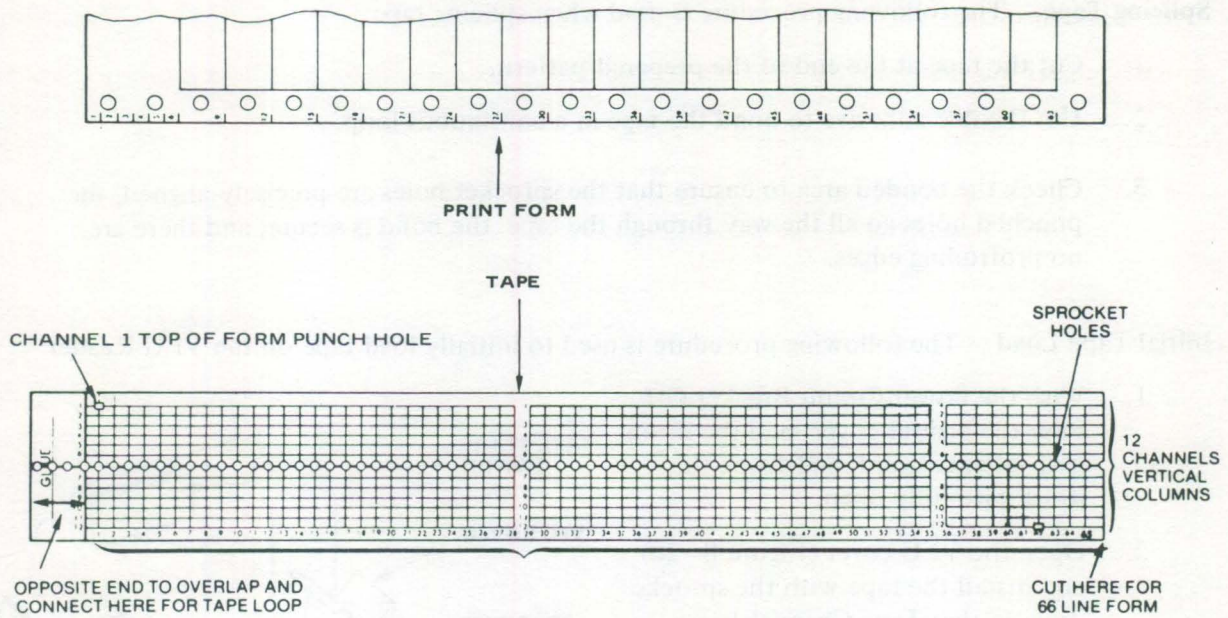

Figure 8-19. VFU Tape

VFU Tape Preparation – The following procedure is used for punching the VFU tape:

1. Use standard 12-Channel Tape (P/N 429754 or equivalent).
2. Since each sprocket hole corresponds to one line of print, the tape loop length, measured in sprocket holes, should be the same as the number of lines per form (page). The value equals the length of the form times the number of lines per inch (6 or 8) to be printed.

For example, if an 11-inch form were used at 6 lines per inch, one would need:

$$11\text{-inch form} \times 6 \text{ lines/inch} = 66 \text{ lines per page, or sprocket holes on the tape loop.}$$

If the same form were printed at 8 lines per inch, the following number of holes would be needed:

$$11\text{-inch form} \times 8 \text{ lines/inch} = 88 \text{ sprocket holes.}$$

3. Punch a $1/16 \times 3/22$ inch tape hole in Channel 1. A Punch P/N 120910 or equivalent should be used to punch the hole at the intersection of the print form line and the first column line.
4. The VFU tape *must* have a minimum of 66 sprocket holes. Thus, if the form contains less than 66 lines, the top-of-form punch must be repeated. For example, a 5-inch form printed at 6 lines per inch has a total length of 30 lines. The tape must contain $3 \times 30 = 90$ sprocket holes, and Channel 1 must be punched once every 30 holes to indicate top-of-form.

Splicing Tape – The following procedure is used when splicing tape:

1. Cut the tape at the end of the prepared pattern.
2. Use flexible adhesive to bond the tape in a continuous loop.
3. Check the bonded area to ensure that the sprocket holes are precisely aligned, the punched holes go all the way through the tape, the bond is secure, and there are no protruding edges.

Initial Tape Load – The following procedure is used to initially load tape on the VFU Reader:

1. With the Power Circuit Breaker Off, raise the printer cover, pull the drum gate latch forward, and swing the drum gate fully open.
2. Open the VFU cover (Figure 8–20) and install the tape with the sprocket drive so that Tape Channel 1 is oriented towards the front of the printer. Ensure that the tape is threaded through the station as shown in Figure 8–20.
3. Close the VFU Reader cover. Close and latch the drum gate, lower the printer cover, and turn the Power Circuit Breaker ON. The tape will load once power stabilizes.
4. The READY Indicator on the Operator Control Panel lights once the tape is loaded.

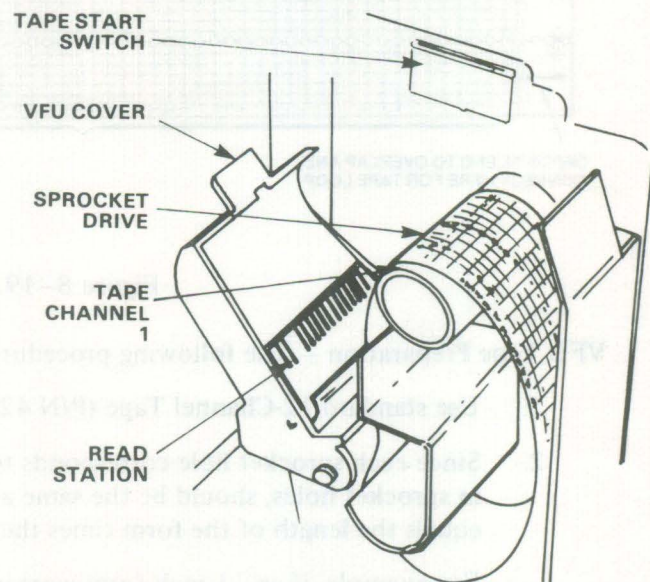

Figure 8–20. VFU Reader

VFU Tape Removal and Installation – The following procedure is used to load a subsequent tape on the VFU Reader during printer operation:

1. Raise the printer cover, pull the drum gate latch forward, and swing the drum gate fully open. *Wait for the line printer drum to stop rotating before proceeding to next step.*

NOTE

Printing is inhibited during the following VFU tape loading operation since unlatching the drum gate puts the printer in an OFF-LINE condition.

2. Open the VFU Tape Reader cover and remove the original tape. Install the new tape with the sprocket holes oriented on the sprocket drive so that Tape Channel 1 is oriented toward the front of the printer. Ensure that the tape is threaded through the Read Station as shown in Figure 8-22.
3. Close the VFU Reader cover, and close and latch drum gate. Press the TAPE START Switch (Figure 8-20) and the tape will load. Lower the printer cover.
4. The READY Indicator on the operator panel lights once the tape is loaded.

Printer Characteristics

Table 8-7 lists the major specifications of the Model 533/536 Line Printer.

TABLE 8-7. MODEL 533/536 LINE PRINTER SPECIFICATIONS

CHARACTERISTIC	SPECIFICATION
CHARACTER SET	64 characters
PRINTING RATE	300 lines per minute (533); 600 lines per minute (536)
PRINTING STRUCTURE	132 characters per line, 10 characters per inch, 6 or 8 lines per inch
PAPER SLEW RATE	20 inches per second
PAPER FEED	Pin feed, adjustable up to 10 ³ / ₄ inch forms
PAPER REQUIREMENTS	Standard paper – carbons produced (original and five copies)
RIBBON SPECIFICATIONS	15 inches wide, black ink; silk, nylon or mylar material (ribbon package includes a pair of disposable plastic gloves)
UNIT DIMENSIONS	44.5 inches high, 33 inches wide, 26 inches deep
WEIGHT	650 pounds
TEMPERATURE	60° to 80°F
RELATIVE HUMIDITY	30% to 80% non-condensating
ELECTRICAL REQUIREMENTS	115 VAC ± 10%, 60 Hz ± 1 Hz
HEAT DISSIPATION	2400 BTU/hour

Table 8-8 lists the major specifications of the Model 539 Line Printer.

TABLE 8-8. MODEL 539 PRINTER CHARACTERISTICS

CHARACTERISTIC	SPECIFICATION
CHARACTER SET	64 characters
PRINTING RATE	900 lines per minute
PRINTING STRUCTURE	132 characters per line, 10 characters-per-inch, 6 or 8 lines per inch
PAPER SLEW RATE	22.5 inches per second
PAPER FEED	Pin feed, adjustable up to 16 ¾ inch forms width
PAPER REQUIREMENTS	Standard paper – carbons produced (original and five copies)
RIBBON SPECIFICATIONS	15 inches wide, black ink; silk, nylon or mylar material (ribbon package includes a pair of disposable plastic gloves)
UNIT DIMENSIONS	44.5 inches high, 33 inches wide, 27.5 inches deep
WEIGHT	420 pounds
TEMPERATURE	60° to 80°F
RELATIVE HUMIDITY	30% to 80% non-condensating
ELECTRICAL REQUIREMENTS	115 VAC ± 10%, 60 Hz ± 1 Hz
HEAT DISSIPATION	2833 BTU/hour

APPENDIX A
PRODUCT LINE FEATURES

APPENDIX A
PRODUCT LINE FEATURES

APPENDIX A PRODUCT LINE FEATURES

Feature	280	380	480	480 (ADEX™)
Hardware				
Keystations (maximum)	16	22	32	32
– Typewriter or 029 style	Yes	Yes	Yes	Yes
– Mixed styles	No	Yes	Yes	Yes
Lines/screen	7	7	10	10/22
Characters/display	360	360	480	480/1920
Roll-up	No	No	Yes	Yes
Disk capacity (standard)	4.8M bytes	4.8M bytes	4.8/33/66Mbytes	4.8/33/66Mbytes
Disk capacity (maximum)		9.6M bytes	66/132Mbytes	66/132Mbytes
– No. of units	1	2	2	2
Tape Drive	9 track, 800 or 1600 bpi 8.5 in., 1200 ft.	7 or 9 track; 556, 800, or 1600 bpi 10.5 in., 2400 ft.	7 or 9 track; 556, 800, or 1600 bpi 10.5 in., 2400 ft.	7 or 9 track; 556, 800, or 1600 bpi 10.5 in., 2400 ft.
– No. of units	1	2	4	4
Software				
Formats/job	10	10	10	10
Program Storage	Unlimited	Unlimited	Unlimited	Unlimited
Fully formatted entry with or without tags	Yes	Yes	Yes	Yes
Entry, Verify, and Examine Modes	Yes	Yes	Yes	Yes
Update mode	No	Yes	Yes	Yes
Validate mode	Supervisor Mode only	Operator & Supervisor	Operator & Supervisor	Operator & Supervisor
Error flag insertion	Yes	Yes	Yes	Yes
Search (any mode) by record number, error flag, field content, or character sequence	Yes	Yes	Yes	Yes
Continuous job status display	Yes	Yes	Yes	Yes
Character insert/delete	Yes	Yes	Yes	Yes
Record insert/delete	Yes	Yes	Yes	Yes
Automatic functions	Yes	Yes	Yes	Yes
Right justification, zero or space fill	Yes	Yes	Yes	Yes
Field boundary, mandatory entry, and completion checks	Yes	Yes	Yes	Yes
Alpha only and numeric only checks	Yes	Yes	Yes	Yes
Program controlled dup, emit, increment, and skip fields	Yes	Yes	Yes	Yes

APPENDIX A PRODUCT FEATURES

Feature	280	380	480	480 (ADEX™)
Ascendency field checks	Yes	Yes	Yes	Yes
Branch field	No	Yes	Yes	Yes
Added and tab fields	Yes	Yes	Yes	Yes
Maximum No. of value tables	20 tables	20 tables	20 tables	20 tables
Maximum No. of Std. value tables (non-ISAM)	20 tables	20 tables	20 tables	20 tables
Indexed value tables (max. optional)	5 Opt.	Sysgenable	Sysgenable	Sysgenable
Output reformatting	Yes	Yes	Yes	Yes
Check digit routines (std.)	7	15	15	15
External Subroutines	No	No	No	Yes
Input record length (characters)	280	280	Unlimited	Unlimited
Standard output record length (characters)	2000	4000	4000	4000
Tape-to-tape copy	No	No	No	Yes
Selective tape unit	No	No	Yes	Yes
Conditional program linkage	No	Yes	Yes	Yes
Command sequence processor	Yes	Yes	Yes	Yes
Batch balance accumulators	4	5	5	5
Multiple operators/batch	Yes	Yes	Yes	Yes
Supervisor access	One station	All stations	All stations	All stations
Supervisor password	Yes	Yes	Yes	Yes
Batch status reports	Yes	Yes	Yes	Yes
Automatic power fail protect	Yes	Yes	Yes	Yes
Output to tape simultaneously with keying	Yes	Yes	Yes	Yes
Operator statistics	Yes	Yes	Yes	Yes
Batch log	Yes	Yes	Yes	Yes
System optimization	No	Yes	Yes	Yes
Automatic batch recovery	Yes	Yes	Yes	Yes
System safeguard	Yes	Yes	Yes	Yes
Individual edit library input	Yes	Yes	Yes	Yes
Batch Edit	Yes	Yes	Yes	Yes
Field End Edit	No	No	No	Yes

Feature	280	380	480	480 (ADEX™)
Record End Edit	Yes	Yes	Yes	Yes
Batch End Edit	No	Yes	Yes	Yes
– Performed on batch termination	No	Yes	Yes	Yes
– Variables (number)	25	99	99	99
Sort/Merge	Opt.	Yes	Yes	Opt. –(Polyphase only)
Output editor	Yes	Yes	Yes	Yes
Multi-level system security	No	No	No	Opt.
Editor Language Features				
Operands:				
Field number	Yes	Yes	Yes	Yes
Numeric literal	Yes	Yes	Yes	Yes
Alphameric literal (max. characters)	40	120	120	120
Variable	Yes	Yes	Yes	Yes
Arithmetic expression	Yes	Yes	Yes	Yes
Indexing	No	Yes	Yes	Yes
Instructions:				
Add	Yes	Yes	Yes	Yes
Audit	No	No	All Modes	All Modes
Back	No	Yes	Yes	Yes
Bypass	Yes	Yes	Yes	Yes
Clear	Yes	Yes	Yes	Yes
Declare	Yes	Yes	Yes	Yes
Divide	Yes	Yes	Yes	Yes
Flag	Yes	Yes	Yes	Yes
Forward	No	Yes	Yes	Yes
Goto	Yes	Yes	Yes	Yes
If	Yes	Yes	Yes	Yes
Link	No	Yes	Yes	Yes
Load	Yes	Yes	Yes	Yes
Move	Yes	Yes	Yes	Yes
Multiply	Yes	Yes	Yes	Yes

Feature	280	380	480	480 (ADEX™)
Note	Yes	Yes	Yes	Yes
Output	Yes	Yes	Yes	Yes
PK	Yes	Yes	Yes	Yes
LS	Yes	Yes	Yes	Yes
LZ	Yes	Yes	Yes	Yes
SG	Yes	Yes	Yes	Yes
TS	Yes	Yes	Yes	Yes
TZ	Yes	Yes	Yes	Yes
'MASK'	Yes	Yes	Yes	Yes
HX	Yes	Yes	Yes	Yes
Output (control functions):				
<ALL mm nn>	Yes	Yes	Yes	Yes
<APPEND>	Yes	Yes	Yes	Yes
<BATCH>	Yes	Yes	Yes	Yes
<BLK n>	Yes	Yes	Yes	Yes
<BSP nnnn>	Yes	Yes	Yes	Yes
<COUNT xxxx>	Yes	Yes	Yes	Yes
<DATE x>	Yes	Yes	Yes	Yes
<DEFER>	Yes	Yes	Yes	Yes
<EOF>	Yes	Yes	Yes	Yes
<HEX xx>	Yes	Yes	Yes	Yes
<JOB>	Yes	Yes	Yes	Yes
<LABEL>	Yes	Yes	Yes	Yes
<LF>	Yes	Yes	Yes	Yes
<PGM>	Yes	Yes	Yes	Yes
<RCD n>	Yes	Yes	Yes	Yes
<RWND>	Yes	Yes	Yes	Yes
<SKIP nnnn>	Yes	Yes	Yes	Yes
<TOP>	Yes	Yes	Yes	Yes
Pause	Yes	Yes	Yes	Yes
Perform	No	Yes	Yes	Yes
Position	No	Yes	Yes	Yes
Release	Yes	Yes	Yes	Yes
Set	No	No	Yes	Yes

Feature	280	380	480	480 (ADEX™)
Sort	Opt.	Yes	Yes	Opt.
Show	Yes	Yes	Yes	Yes
Stop	Yes	Yes	Yes	Yes
Subtract	Yes	Yes	Yes	Yes
When	Yes	Yes	Yes	Yes
When Batch	Yes	Yes	Yes	Yes
When EOT	Yes	Yes	Yes	Yes
When (Not) Field	Yes	Yes	Yes	Yes
When Flag	Yes	Yes	Yes	Yes
When Overflow	Yes	Yes	Yes	Yes
When (Not) PGM n	n=0—9	n=0—9	n=0—9	n=0—9
When Start	Yes	Yes	Yes	Yes
When Mode	Yes	Yes	Yes	Yes
Peripherals				
Remote keystation operation	Yes	Yes	Yes	Yes
Binary Synchronous Communications	Yes	Yes	Yes	Yes
Standard 3270 Emulation	No	No	No	Opt.
Communications Dynamic Trace	Yes	Yes	Yes	Yes
Card Reader	Yes	Yes	Yes	Yes
Second 45 char./second terminal printer	No	No	No	Yes
300 line/minute terminal line printer	No	No	No	Yes
165 character/second system printer	Yes	Yes	Yes	Yes
300 line/minute system line printer	Yes	Yes	Yes	Yes
600 line/minute system line printer	Yes	Yes	Yes	Yes
900 line/minute system line printer	Yes	Yes	Yes	Yes
Data Redundancy	No	No	No	No

APPENDIX B

TAPE OUTPUT CODES IN OCTAL/HEXADECIMAL NOTATION

APPENDIX B

TAPE OUTPUT CODES IN OCTAL/HEXADECIMAL NOTATION

APPENDIX B
TAPE OUTPUT CODES IN OCTAL/HEX NOTATION

KEYBOARD	EBCDIC ₈	ASC11	BCD	H-2000	ICL-7	H-6000	EBCDIC ₁₆
A	301	101	61	21	35	21	C1
B	302	102	62	22	36	22	C2
C	303	103	63	23	37	23	C3
D	304	104	64	24	30	24	C4
E	305	105	65	25	31	25	C5
F	306	106	66	26	32	26	C6
G	307	107	67	27	33	27	C7
H	310	110	70	30	24	30	C8
I	311	111	71	31	25	31	C9
J	321	112	41	41	26	41	D1
K	322	113	42	42	27	42	D2
L	323	114	43	43	20	43	D3
M	324	115	44	44	21	44	D4
N	325	116	45	45	22	45	D5
O	326	117	46	46	23	46	D6
P	327	120	47	47	14	47	D7
Q	330	121	50	50	15	50	D8
R	331	122	51	51	16	51	D9
S	342	123	22	62	17	62	E2
T	343	124	23	63	10	63	E3
U	344	125	24	64	11	64	E4
V	345	126	25	65	12	65	E5
W	346	127	26	66	13	66	E6
X	347	130	27	67	04	67	E7
Y	350	131	30	70	05	70	E8
Z	351	132	31	71	06	71	E9
0	360	060	12	00	74	00	F0
1	361	061	01	01	75	01	F1
2	362	062	02	02	76	02	F2
3	363	063	03	03	77	03	F3
4	364	064	04	04	70	04	F4
5	365	065	05	05	71	05	F5
6	366	066	06	06	72	06	F6
7	367	067	07	07	73	07	F7
8	370	070	10	10	64	10	F8
9	371	071	11	11	65	11	F9

KEYBOARD	EBCDIC ₈	ASC11	BCD	H-2000	ICL-7	H-6000	EBCDIC ₁₆
SP	100	040	20	15	54	20	40
¢	112	(^) 136	72	77	(£) 50	37	4A
.	113 [\$]	056	73	33	42	33	4B
<	114	074	74	60	60	36	4C
(115	050	75	74	44	35	4D
+	116	053	76	20	47	60	4E
	117	(/) 134	—	(CR) 75	(↑) 02	12	4F
&	120	046	60	17	52	32	50
!	132	041	52	57	55	77	5A
\$	133 [£]	044	53	53	00	53	5B
*	134	052	54	54	46	54	5C
)	135	051	55	34	45	55	5D
:	136	073	56	32	67	56	5E
⌋	137	(j) 135	—	(≠) 56	(j) 01	40	5F
—	140	055	40	40	41	52	60
/	141	057	21	61	43	61	61
≠	152			56			
,	153	054	33	73	40	34	6B
%	154	045	34	35	51	73	6C
—	155	137	35	(□) 76	(←) 03	72	6D
>	156	076	36	16	62	16	6E
?	157	077	37	37	63	17	6F
:	172	072	—	14	66	15	7A
#	173	043 [£]	13	52	57	13	7B
@	174	100	14	72	34	14	7C
'	175	047	15	12	53	57	7D
=	176	075	16	13	61	75	7E
”	177	042	17	55	56	76	7F
(ϕ)	300	053	76	20	47	60	
(σ)	320	055	40	40	41	52	

() = Corresponding character
[] = U.K. Version

APPENDIX C

ABL LOG CODES AND DEFINITIONS

APPENDIX C
ABL LOG CODES AND DEFINITIONS

APPENDIX C. ABL LOG CODES AND DEFINITIONS

NUMBER	DEFINITION
1	ABL DATA TAPE GENERATOR MAY NOT HAVE RECOVERED ALL BATCHES.
2	ABL DATA TAPE GENERATOR MAY NOT HAVE RECOVERED ALL OPERATOR ID'S AND STATISTICS.
3	BATCH WAS SKIPPED BY ABL DATA TAPE GENERATOR.
4	AN OPERATOR'S ID AND STATISTICS WERE SKIPPED BY ABL DATA TAPE GENERATOR.
5	BATCH MAY NOT HAVE BEEN COMPLETELY WRITTEN BY ABL DATA TAPE GENERATOR.
6	AN OPERATOR'S STATISTICS MAY NOT HAVE BEEN COMPLETELY WRITTEN BY ABL DATA TAPE GENERATOR.
7	TAPE IS NOT AN ABL TAPE.
8	STANDARD JOB IS NOT DEFINED IN STANDARD JOB LIBRARY.
9	INPUT FORMAT IS NOT DEFINED IN INPUT FORMAT LIBRARY.
10	BATCH END EDIT ROUTINE IS NOT DEFINED IN THE BATCH END EDIT LIBRARY OR CONTAINS ONE OR MORE COMPILATION ERRORS.
11	RECORD END EDIT ROUTINE NOT DEFINED IN THE RECORD END EDIT LIBRARY OR CONTAINS ONE OR MORE COMPILATION ERRORS.
12	NO INPUT FORMAT FOUND TO INITIATE BATCH.
13	BATCH OR OPERATOR ID ALREADY EXISTS.
14	ABL TAPE INPUT HAS BEEN TERMINATED DUE TO TAPE READ ERROR.
15	DISK IS 98% FULL. ALL FURTHER BATCHES AND OPERATOR STATISTICS ON TAPE WILL BE BYPASSED, AND THE NAMES WILL BE LISTED.

APPENDIX C. ABL LOG FILES AND DEFINITIONS

NUMBER	DEFINITION
1	ABL DATA TAP GENERATOR MAY NOT HAVE RECOVERED ALL BATCHES
2	ABL DATA TAP GENERATOR MAY NOT HAVE RECOVERED ALL OPERATOR ID'S AND STATISTICS
3	BATCH WAS SKIPPED BY ABL DATA TAP GENERATOR
4	AN OPERATOR'S ID AND STATISTICS WERE SKIPPED BY ABL DATA TAP GENERATOR
5	BATCH MAY NOT HAVE BEEN COMPLETELY WRITTEN BY ABL DATA TAP GENERATOR
6	AN OPERATOR'S STATISTICS MAY NOT HAVE BEEN COMPLETELY WRITTEN BY ABL DATA TAP GENERATOR
7	TAP IS NOT AN ABL TAP
8	STANDARD JOB IS NOT DEFINED IN STANDARD JOB LIBRARY
9	INPUT FORMAT IS NOT DEFINED IN INPUT FORMAT LIBRARY
10	BATCH END EDIT ROUTINE IS NOT DEFINED IN THE BATCH END EDIT LIBRARY OR CONTAINS ONE OR MORE COMPILE ERRORS
11	RECORD END EDIT ROUTINE NOT DEFINED IN THE RECORD END EDIT LIBRARY OR CONTAINS ONE OR MORE COMPILE ERRORS
12	NO INPUT FORMAT FOUND TO INITIATE BATCH
13	BATCH OR OPERATOR ID ALREADY EXISTS
14	ABL TAP INPUT HAS BEEN TERMINATED DUE TO TAP READ ERROR
15	DISK IS OFF FULL. ALL FURTHER BATCHES AND OPERATOR STATISTICS ON TAP WILL BE BYPASSED AND THE NAMES WILL BE LISTED

APPENDIX D
CENTRAL PROCESSOR CONTROLS

APPENDIX D
CENTRAL PROCESSOR CONTROLS

APPENDIX D CENTRAL PROCESSOR CONTROLS

All systems manufactured after June, 1977 are equipped with a different Central Processor from earlier models. The architecture, programming, and response of both computers are identical; only the switches available to the user are different. Figure D-1 illustrates the front panel layout for the new Central Processor.

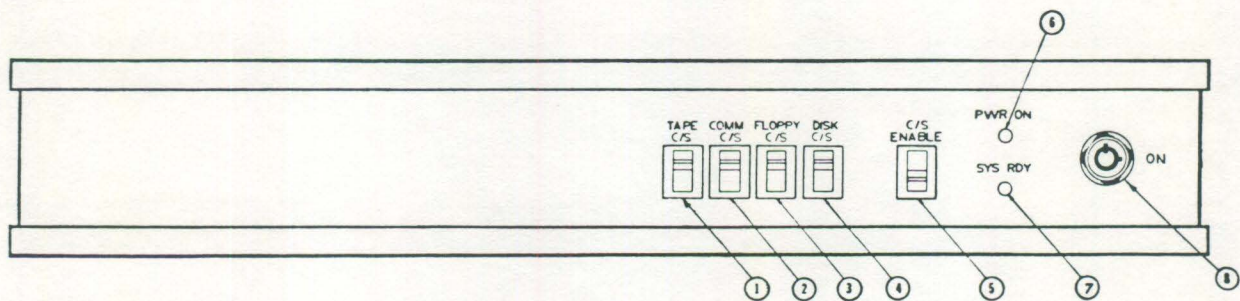

- | | |
|-------------------------------------|-----------------------------|
| 1. TAPE COLD START SWITCH | 5. COLD START ENABLE SWITCH |
| 2. COMMUNICATIONS COLD START SWITCH | 6. POWER ON INDICATOR |
| 3. DISKETTE COLD START SWITCH | 7. SYSTEM READY INDICATOR |
| 4. DISK COLD START SWITCH | 8. POWER LOCKING SWITCH |

Figure D-1. Central Processor Control Panel

All switches are spring loaded. Therefore, if any cold start operation is to be performed, both the Cold Start Enable Switch and the tape or disk cold start switch must be held in place at the same time. The operation of the cold start operations are otherwise unchanged.

There are no maintenance indicators on the front panel for supervisory reference. There are also no toggle switches to set the control for ECHO mode.

APPENDIX B - CENTRAL PROCESSOR CONTROLS

All systems manufactured after June 1977 are equipped with a different Central Processor from earlier models. The air resistance, programming and a series of built-in components are located into the system available to the user on the front panel. Figure B-1 illustrates the front panel layout for the new Central Processor.

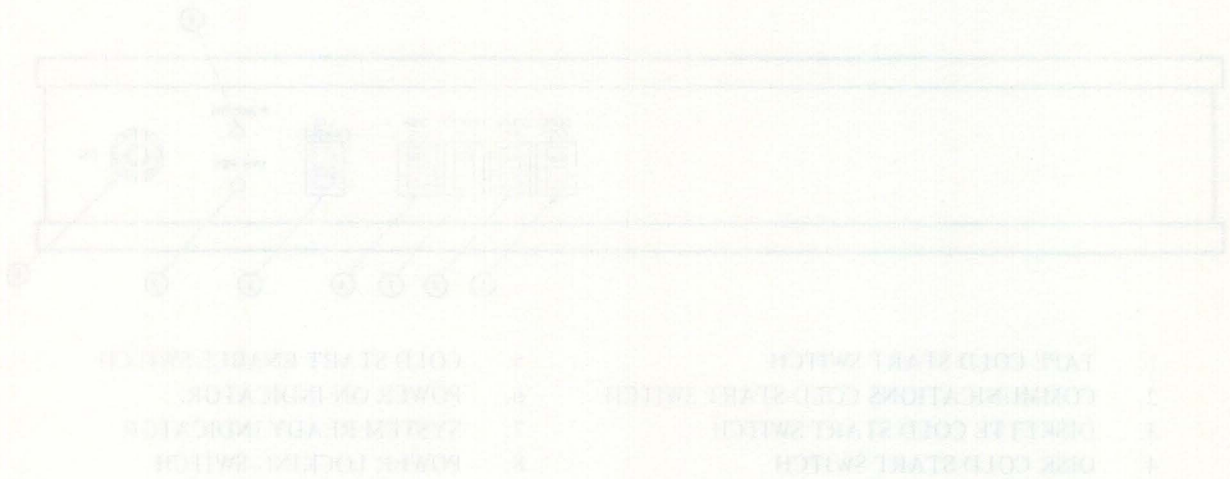

Figure B-1 - Central Processor Control Panel

All switches are spring loaded. Therefore, a single contact operation is to be performed, push the Cold Start Switch and the tap cold start switch must be held in place at the same time. The operation of the cold start signal is not a continuous condition.

There are no maintenance indicators on the front panel for the processor. However, the logic switches to set the control for the logic.

INDEX

INDEX

INDEX

- Accumulators, 5-5, 7-2
- Append, 3-6, 3-9
- Ascending Order
 - Indexed Value Tables, 2-9
 - Sort, 2-6
 - Value Tables, 2-9
- Asterisk Processor, 2-1, 5-11, 5-38
- AT Sign Convention, 2-1
- AUTO Functions, 1-5
- Automatic Batch Load (ABL)
 - Batch Recovery, 6-19
 - Cold Start, 6-19, 6-21
 - General Operating Parameters, 6-19
 - Generator Tapes, 6-25
 - Log, 6-20, 6-24, C-1
 - Multi-Reel Generation/Load, 6-25
 - Procedure for Generation/Load, 6-20ff
 - System Malfunction, 6-26, 6-27
 - Upgrading of Software, 6-19
- Batch
 - Append, 3-6, 3-9
 - Balancing, 5-5
 - Delete, 2-4
 - Display Status, 2-2
 - Edit, 2-4
 - End Edit, 2-4, 5-7
 - I/O Operations, Section 3
 - Log, 2-4, 3-4
 - Protection, 2-13
 - Read, 2-6
 - Read with Standard Job Header, 3-9
 - Rename, 2-5
 - Sort, 2-6
 - Status Tape Layout, 3-4
 - Write, 3-1
 - Write Status, 3-3
- Bids, 4-35
- Binary Synchronous Communications, 4-15
- BISYNC ANALYZER, 4-37ff, 6-10
- Block Size, 3-2, 4-26
- Blocked Records, 3-2
- Buffer, 4-32
- Central Disk, 1-9, 7-5
- Central Processor Unit (CPU), 1-8, Section 7
- Character(s)
 - Count, 3-3
 - Fill Mode, 4-8
 - Fill, 5-5
 - Padding/Skip, 3-3
- Check Digits, 5-28
- Code Sets
 - ASCII, 5-18
 - BCD, 5-18
 - Conversion Table, 5-19
 - Entering in Library, 5-17
 - File Mode, 4-8
 - Hexadecimal/Octal, 5-17
 - Specifying for Batch Output, 3-3
 - System Tape, 5-18, 6-6
 - Tape, 4-8
- Cold Start
 - Disk Pack, 6-10
 - Disk Switch, 7-3, 7-11
 - Enable Indicator, 7-4

- Enable Switch, 7-3, 7-11
- Tape, 7-10
- Tape Switch, 7-3
- Command Sequence
 - Asterisk Processor, 2-1, 5-11
 - Coding, 5-12, 5-14
 - Execution, 5-15
 - Instructions, 5-14
 - Layout Form, 5-13
 - Library Maintenance, 5-16
 - Operational Features of Performance, 5-11, 5-12
 - With Display Batch Status Feature, 2-2
 - With Sort, 2-7
 - Write Libraries Feature, 5-38
- Communications
 - Binary Synchronous, 4-15
 - Code Sets, 4-25
 - Control Characters, 4-26ff, 4-37ff
 - Data Access Arrangement, 4-15
 - Data Compression, 4-25
 - Data Record, 4-15
 - Data Transmission Block, 4-16
 - Dynamic Trace, 4-37ff
 - Error Recovery, 4-39
 - Nixdorf To/From Nixdorf, 4-13, 4-25
 - Nixdorf To/From non-Nixdorf, 4-25
 - Extended Enquiry, 4-25, 4-26
 - Extended Handshaking, 4-25, 4-39
 - Horizontal Tab, 4-26
 - IBM Emulation, 4-25
 - Leased Line Conditioning, 4-16
 - Leased Private Service, 4-16
 - Line Bids, 4-35
 - Line Speed Transmission, 4-25
 - Modems, 4-16
 - Operations, 4-18ff
 - Overview, 4-13
 - Parameterized Communications, 4-14, 4-27, 6-6
 - Record Size, 4-15, 4-25
 - Remote Entry, 4-14, 4-25
 - Retries, 4-36
 - Switched Network, 4-16
 - Transmission Lines, 4-17
 - Transmission/Reception, 4-19ff, 4-40
 - Utilities, 4-17
 - Vocabulary, 4-15
- Compression, 4-29, 4-33
- Control Characters, 4-26, 4-27
- Cyclic Redundancy Checking (CRC), 7-5
- Cursor
 - Backspace, 1-5
 - Definition, 1-4
 - Forward, 1-5
 - Left/Right, 1-5
 - With LOC RET, 1-7
- Data
 - Compression, 4-29, 4-33
 - Discipline, 4-33
 - Display, 1-3
 - Formatting in Communications, 4-31
 - Reformatting, 5-8
 - Presentation, 1-4
 - Record, 4-15
 - Set, 4-15
 - Terminal, 4-16
 - Transmission Blocks, 4-16
- DATA/TERMINAL
 - Description, 1-1
 - Maintenance, 7-9
- Delimiter, 1-4
- Descending Order
 - Indexed Value Tables, 2-9
 - Sort, 2-6
 - Value Tables, 2-9
- Device, I/O
 - Specifying for Batch Output, 3-2, 3-3
 - Utility Operations Options, 4-1, 4-6

Diagnostic Mode

- Communications Dynamic Trace, 6-10
- ECHO, 6-8
- Feature Defined, 6-8
- Replace Disk Pack Option, 6-10

Disk

- Bytes of Storage, 7-5
- Cartridge, 6-2
- Central, 1-9, 7-5
- Cold Start, 7-3, 7-4
- Controls, 7-5
- Pack, 6-2
- Pack 33 MB Operation, 6-10
- Pack Replacement Option, 6-10
- Status Warnings, 6-1
- Types, 6-10

Display Presentation, 1-3

ECHO

- Data Switch Arrangement, 6-9
- Description, 6-8

Editor

- AUTO Functions, 5-11
- Coding, 5-5ff

Edits

- Batch, 2-4
- Batch End, 2-4
- Coding, 5-9
- Record End, 5-5

Enter Date, 6-1

Environmental Conditions, 7-8, 7-9

Error Messages

- CRT Display, 1-3
- With Code Sets, 5-17
- With Command Sequence, 5-16

Error Recovery Procedures, 4-39

Error Tone, 1-5

Field

- Count, 1-3
- Input Specifications, 5-5

Key, with Value Tables, 2-10

Tag/Delimiter, 1-4

Format

- Linkage Selection, 3-5
- Record, 5-5

Format Disk, 6-25

Handshaking, 4-25, 4-39

Hardware, Section 7, 8

Malfunction, 6-3

HELP Lists, 1-7, 1-8

Horizontal Tab, 4-29, 4-33

Indexed Value Tables, 2-10

Indicators (CPU), 7-3ff

Input Format

- Coding Form, 5-10
- Format Number, 1-3

Key(s)

- AUTO, 1-5
- Function, 1-6, 1-7
- Sort, 2-6
- Value Table Field, 2-10

Keyboard

- Description, 1-5
- Function Keys, 1-5
- Illustration, 1-7

Keystation

- Characteristics, 1-1
- Illustration, 1-2

Leading Graphics, 4-29, 4-36

Libraries

- Batch End Edit, 5-7
- Check Digit, 5-26
- Code Set Conversion, 5-16
- Command Sequence, 5-12, 5-16
- Individual Editor Input, 5-9
- Input Format, 5-4
- Operator Statistics, 5-18
- Output Program, 5-7
- Read All Libraries, 5-37

- Record End Edit, 5-5
- Sort Program, 5-9
- Standard Job, 5-22
- Write All Libraries, 5-38
- Line(s)
 - Bids, 4-35
 - Feeds, After/Before Print, 4-9
 - Leased, Conditioning, 4-16
 - Number Per Page, 4-10
 - Private, 4-16
 - Speed Transmission, 4-25
- Linkage, 3-5
- Log
 - ABL, 6-20, 6-24, C-1
 - Batch, 2-4, 3-4
- Magnetic Tape
 - BOT and EOT Marks, 4-2
 - Conventions, 4-2
 - Drive Operation, 7-6
 - General Description, 1-9
 - Record Format, 4-2
 - Specifications, 7-6
- Modems, 4-15
- Multi-Reel Tapes, 6-4, 6-25
- Numeric Only Exceptions, 6-7, 6-8
- Operator Statistics, 5-18ff
- Optimize System
 - Description, 6-15, 6-16
 - Illustration, 6-17, 6-18
- Output
 - Batch Protection, 2-13
 - Coding, 5-7
 - Program, 5-7
 - Reformatting, 5-8
 - Specifications, Section 3
 - Standard Job, 3-1
- Oversign, 6-14
- Parameterized Communications
 - Buffer, 4-32, 4-33
 - Code Set, 4-33
 - Data Compression, 4-29, 4-33
 - Data Discipline, 4-33
 - Data Formatting, 4-31
 - Definition, 6-8
 - Dynamic Trace, 4-37ff
 - Horizontal Tab, 4-29, 4-33
 - IBM Emulation, 4-30, 4-31, 4-33, 4-34
 - Intermediate Record Separators, 4-29, 4-34
 - Leading Graphics, 4-29, 4-36
 - Line Bids, 4-35
 - Operating Parameters, 4-27ff
 - Overview, 4-14
 - Polling/Addressing Sequence, 4-29, 4-36
 - Record(s), 4-31
 - Retries, 4-36
 - Transparency, 4-29, 4-33
- Password, 6-7
- Peripheral Devices, Section 8
- PGM-HELP
 - Description, 2-2
 - In Communications, 4-26
- Polling Sequence, 4-29, 4-36
- Printer, 8-3ff
- Product Line Features, Appendix A
- Random
 - Access Disk, 7-5
 - Value Table, 2-8
- Read
 - All Libraries, 5-37
 - Batch, 3-6
 - Standard Job, 3-5
 - With Standard Job Header, 3-9
- Record
 - Blocked for Output, 3-2
 - Coding, 5-5

- Count, 1-3
- End Edit, 3-5
- Fixed Length for Output, 3-2
- Length, 4-8
- Linkage, 3-5
- Number/Buffer, 4-31, 4-32
- Separators, 4-34, 4-35
- Size, 3-2, 4-25
- Variable Length, 3-2
- Registers, 7-2
- Remote Entry, 4-14, 4-25
- Rescue, 6-21
- Save
 - Multi-Reel Generation/Load, 6-4
 - Procedure, 6-2ff
 - System, 6-2
 - System Save Tapes, 7-10
- Search
 - Ascending/Descending for Value Tables, 2-9
 - For Tape Mark, 4-1, 4-4
 - For Tape Sequence, 4-1, 4-4
 - Random for Value Tables, 2-11
- Software
 - Master System Tape, 7-10
 - Upgrading Level of, 6-19
- Sort
 - Batch, 2-6
 - Execution, 2-7
 - File, 2-6
 - Keys, 2-6, 5-9
 - Order, Ascending/Descending, 2-6
- Standard Job
 - Definition, 5-2ff
 - Output, 3-1
 - Read with Standard Job Header, 3-9
 - Write/Read, 5-4
- Storage, 4-32, 7-5
- Supervisor Functions
 - Description, 1-9
 - HELP List, 1-9
 - Options, 1-10, 1-11
 - Password, 1-8, 6-7
- Switched Network, 4-16
- Switches, CPU, 7-3
- System
 - Malfunction, 6-3
 - Operations, 7-2ff
 - Overview, 1-1
 - Tape(s), 7-10
 - Tape Code, 6-6
- Tag, 1-4
- Tape(s)
 - ABL Generator, 6-25
 - Assign Unit, 6-5
 - Batch Processing, 3-6
 - Blocks, 4-3
 - Cold Start, 7-10, 7-11
 - Drive, 7-6
 - Four-by-Three Packing, 6-6
 - Handling Options, 4-1, 4-3
 - Input Operations, 3-7
 - Loading/Unloading Procedures, 7-7
 - Magnetic, 4-2, 7-6, 7-10
 - Mark, 4-3
 - Master Library, 7-10
 - Master System, 7-10
 - Octal/Hexadecimal Notation, 5-17
 - Output Codes, 4-8
 - Record Backspace, 4-4
 - Record Format, 4-8
 - Rewind, 4-4, 4-5
 - Scratch, 7-10
 - Search, 4-1, 4-4
 - Selective Input, 3-6

- System Save, 7-10
- System Tape Code, 7-10
- System Software, 7-10
- To Print Operation, 4-12
- To Print Restrictions, 4-11
- Types, 7-6
- Unit Maintenance, 7-9
- Utility Operations, 4-1ff
- Value Table Rescue, 6-21
- With ABL, 6-22
- Write, 4-3
- Write Mark, 4-1
- Trace, 4-37ff
- Transaction File, 3-8
- Transparency, 4-29, 4-33
- Typewriter
 - Keyboard Styles, 1-5, 1-6
 - Oversign, 6-14
- Utilities Options, 4-1
- Valid/Invalid Entries, 2-8

Valid/Invalid Matching Names

- Definition, 2-1
- In Sort, 2-7

Value Tables

- Ascending/Descending/Random Search, 2-8, 2-9
- Batch Format, 2-10
- Feature Description, 2-7ff
- Format Entries, 2-10
- Operating Procedures, 2-10, 2-11
- Reference Numbers, 2-12
- Rescue Tapes with ABL, 6-18
- Valid/Invalid Entries, 2-9

Warm Start

- Disk Pack, 6-13
- General Features, 7-11
- Procedure, 7-11, 7-12

Write

- All Libraries, 5-38
- To Print, 3-2
- To Tape, 3-2

Technical Publications Remarks Form

Please use this form to submit your suggestions for revisions, corrections, or additions to this publication. Your comments will be promptly investigated by appropriate technical personnel, and action will be taken as required. If your answer to any of the questions is 'NO' or requires qualification, please include any additional comments on a separate sheet and enclose it inside this pre-addressed form.

TITLE :

ORDER No.

DATED

YES NO

DOES THIS DOCUMENT MEET YOUR NEEDS? _____

IS THE MATERIAL CONTAINED IN THIS DOCUMENT :

ACCURATE? _____

EASY TO READ AND UNDERSTAND? _____

ORGANIZED FOR CONVENIENT REFERENCING? _____

WELL ILLUSTRATED WITH USEFUL EXAMPLES? _____

COMPLETE? _____

ERRORS IN THE PUBLICATION

SUGGESTIONS FOR IMPROVEMENT

(Please Print)

FROM : NAME _____ DATE _____

ORGANIZATION _____

ADDRESS _____

TITLE _____

MARKET RESEARCH
TECHNICAL PUBLICATIONS
CORPORATION

Technical Publications Reply Form

Thank you for taking the time to complete this form. Your response will be used to help us better serve you. We will not share your information with anyone else. If you have any questions, please contact us at 1-800-343-7272.

ORDER NO. _____ TITLE _____
DATED _____

YES _____ NO _____
DOES THIS DOCUMENT MEET YOUR NEEDS?
IS THE MATERIAL CONTAINED IN THIS DOCUMENT
ACCURATE?
EASY TO READ AND UNDERSTAND?



NO POSTAGE
NECESSARY
IF MAILED
IN THE
UNITED STATES

BUSINESS REPLY MAIL
FIRST CLASS PERMIT NO. 228 BURLINGTON, MA

POSTAGE WILL BE PAID BY ADDRESSEE

NIXDORF COMPUTER CORPORATION
Attn: Marketing Technical Publications
168 MIDDLESEX TURNPIKE
BURLINGTON, MASSACHUSETTS 01803

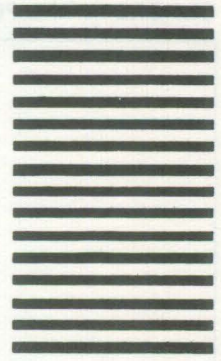

SUGGESTIONS FOR IMPROVEMENT

FROM _____ NAME _____
ORGANIZATION _____
ADDRESS _____
TITLE _____

NIXDORF
COMPUTER