

HP 88780B Tape Drive User's Guide

HP 88780B Tape Drive User's Guide

HP Part No. 88780-90010

Edition 2
E0590
May, 1990
Printed in U.S.A. 05/90

Notice

Hewlett-Packard makes no warranty of any kind with regard to this printed material, including, but not limited to, the implied warranties of merchantability and fitness for a particular purpose. Hewlett-Packard shall not be liable for errors contained herein or for incidental or consequential damages in connection with the furnishing, performance, or use of this material.

© Copyright 1989, 1990 Hewlett-Packard

This document contains proprietary information, which is protected by copyright. All rights are reserved. No part of this document may be photocopied, reproduced, or translated to another language without the prior written consent of Hewlett-Packard Company. The information contained in this document is subject to change without notice.

Greeley Storage Division
700 71st Avenue
Greeley, CO 80634

FCC Radio Frequency Interference Statement (USA Only)

Warning: This equipment generates, uses, and can radiate radio frequency energy and, if not installed and used in accordance with the instruction manual, may cause interference to radio communications. It has been tested and found to comply with the limits for a Class A computing device pursuant to Subpart J of Part 15 of FCC Rules, which are designed to provide reasonable protection against such interference when operated in a commercial environment. Operation of this equipment in a residential area is likely to cause interference, in which case the user at his own expense will be required to take whatever measures may be required to correct the interference.

German Electromagnetic Interference Regulations

Manufacturer's Declaration (English translation)

This is to certify that the HP 88780B is in accordance with the Radio Interference Requirements of Directive FTZ 1046/84. The German Bundespost was notified that this equipment was put into circulation, and the right to check the series for compliance with the requirements was granted. If this equipment is to be operated with a system

- and if the General License is being claimed, the complete system has to comply with the General Licensing requirements.
- which has its own FTZ-Serial License, and for which an operating license has been granted or requested, usually no further steps are necessary.

Funkentstörung Deutschland

Herstellerbescheinigung

Hiermit wird bescheinigt, daß das Gerät HP 88780B in Übereinstimmung mit den Bestimmungen von Postverfügung 1046/84 funkentstört ist. Der Deutschen Bundespost wurde das Inverkehrbringen dieses Gerätes angezeigt und die Berechtigung zur Überprüfung der Serie auf Einhaltung der Bestimmungen eingeräumt. Wird das Gerät innerhalb einer Anlage betrieben

- so muß bei Inanspruchnahme der Allgemeinen Genehmigung FTZ 1046/84 die gesamte Anlage der oben genannten Genehmigung entsprechen.
- die mit einer FTZ-Serienprüfnummer gekennzeichnet ist, und für die eine Betriebsgenehmigung vorliegt oder beantragt wird, so sind in der Regel keine weiteren Schritte notwendig.

Japanese VCCI Statement

この装置は、第一種情報装置(商工業地域において使用されるべき情報装置)で商工業地域での電波障害防止を目的とした情報処理装置等電波障害自主規制協議会(VCCI)基準に適合しております。

従って、住宅地域またはその隣接した地域で使用すると、ラジオ、テレビジョン受信機等に受信障害を与えることがあります。

取扱説明書に従って正しい取り扱いをして下さい。

About This Guide

This guide is written for operators trained in systems, and assumes a familiarity with computer terms and tape drive operation.

The guide is organized so that the information needed to get the drive up and running quickly is generally in the front. More detailed information about drive operation, troubleshooting, and installation is placed more towards the back of the guide.

The following chart is a brief overview of where information can be found.

If you would like to	Read	And then move to
Review drive features and characteristics	<i>Chapter 1</i>	<i>Appendix B</i>
Power-up quickly	<i>Chapter 2, page 2-1</i>	
Follow detailed operating steps	<i>Chapter 2, page 2-3</i>	<i>Chapter 3</i>
...and autoloading instructions	<i>Chapter 2, page 2-5</i>	
Understand the Control Panel	<i>Chapter 2, page 2-9</i>	
Troubleshoot the drive	<i>Chapter 3</i>	
Run a diagnostic	<i>Chapter 3, page 3-3</i>	
Study tape path guidelines	<i>Chapter 4, page 4-2</i>	
...or tape library management	<i>Chapter 4, page 4-4</i>	
Select an installation site	<i>Appendix A, page A-1</i>	
Configure the drive	<i>Appendix A, page A-2</i>	
Learn or review system commands	<i>System manuals</i>	

Safety Considerations

Please be familiar with the following safety markings and instructions before operating the tape drive.

WARNING

WARNING calls attention to a procedure or practice which could result in personal injury if not correctly performed. Do not proceed beyond a **WARNING** sign until you fully understand and meet the indicated conditions.

CAUTION

CAUTION calls attention to an operating procedure or practice which could result in damage to the product or magnetic tape if not correctly performed. Do not proceed beyond a **CAUTION** sign until you fully understand and meet the indicated conditions.



This international caution symbol indicates that the operator should refer to the product instruction manual before beginning a procedure.



This symbol indicates hazardous voltages.



This symbol indicates an earth (ground) terminal.

WARNING



(Documents) Calls attention to a procedure or practice which could result in personal injury if not correctly performed. Do not proceed beyond this symbol until you fully understand and meet the indicated conditions.

CAUTION



(Documents) Calls attention to an operating procedure or practice which could result in damage to the product or magnetic tape if not correctly performed. Do not proceed beyond this symbol until you fully understand and meet the indicated conditions.

NOTE



(Documents) Calls attention to information which can be helpful in understanding the operation of the product.

Power and Grounding

This is a Safety Class I product and is provided with a protective earthing terminal. An uninterruptible safety earth ground must be provided from the main power source to the product input wiring terminals, power cord, or supplied power cord set. Whenever it is likely that this protection has been impaired, be certain that you do not operate the drive until the unit is repaired.

Verify that the product is configured to match the available main power source. If this product is to be operated with an autotransformer, make sure that the common terminal is connected to the earth terminal of the main power source.

Servicing

Any servicing, adjustment, maintenance, or repair of this product, other than that described within this document, must be performed only by service personnel trained by Hewlett-Packard.

Table of Contents

	Notice	i
	Regulatory Statements	ii
	About This Guide	iii
	Safety Considerations	iv
Chapter 1		
Introduction	Before You Begin	1-1
	About The HP 88780B	1-1
	Extra Capacity Data Storage (Option 400)	1-2
	Ordering Options on the HP 88780B	1-4
Chapter 2		
Operation	Quick Start	2-1
	Procedures	2-3
	Poweron	2-3
	Loading Tape	2-4
	Unloading Tape	2-9
	The Control Panel	2-9
Chapter 3		
Troubleshooting and Diagnostics	Overview	3-1
	Error Messages	3-1
	Displaying the Error Logs	3-2
	Internal Diagnostics	3-3
	Available Tests	3-4
	Running Tests	3-5
	Other Corrective Actions	3-6
	Tape Does Not Autoload	3-6
	Control Panel Lights Do Not Come On	3-8
	Density and Unload/Rewind Keys Do Not Operate Correctly	3-9
	Power Failure Recovery Incomplete	3-10
	BOT/EOT Markers Must Be Replaced	3-12
	Tape and Tape Path Not Clean	3-12
Chapter 4		
Tape Management	Overview	4-1
	Tape and Tape Path Problems	4-1
	Tape Path Care	4-2
	Cleaning Schedule	4-2
	Cleaning Supplies	4-3
	Cleaning Procedure	4-3
	Tape Library Care	4-4
	Storage	4-5
	Transportation	4-5
	Handling	4-5
	Winding	4-5
	Evaluation	4-6
	Labeling	4-6
	Resources	4-7

**Appendix A
Set up and
Configuration**

Site Selection A-1
Setting the ADDRESS/ID Number A-2
Configurations A-2
Setting a Configuration Option A-7
Customizing Drive Operation A-8
 Changing Rewind Speeds A-8
 Monitoring the Extra Capacity Data Storage Rate (Option 400) A-11
Changing the Voltage Configuration A-12

**Appendix B
Technical
Specifications**

Drive Specifications B-1
Tape Specifications B-2
Environmental Specifications B-2
Using 1-Mil Tape B-4

Glossary G-1

1

Introduction

Before You Begin

Inspect the new tape drive and its packaging. Does anything on the shipping container indicate rough handling? Is the drive damaged in any way? If you see or suspect any damage, call your HP products distributor. Also, contact the carrier that delivered the drive.

Appendix A explains setting up and configuring the drive.

About The HP 88780B

The HP 88780B is an autoloading, horizontally-mounted, 1/2-inch reel-to-reel tape drive. This drive is designed for superior performance with simple operation, and features the latest in storage technologies:

- compact, ergonomic design
- front autoload
- simplified control panel
- versatile handling of all standard-sized reels (6 to 10 1/2-inch)
- 125 ips nominal tape speed for maximum streaming performance
- density configuration as needed: the drive supports both 1600 cpi Phase Encoded (PE) and 6250 cpi Group-Coded Recording (GCR). Also, 800 cpi Non-Return to Zero Inverted (NRZI) is supported if the drive is equipped with Option 800.
- 512-Kbyte cache buffer for fast transfers during start-stop applications
- easy-to-use diagnostics
- custom operating features, selected by the operator from the control panel
- low power consumption

If you have Extra Capacity (XC) capability (Option 400) you also have:

- operator, or Host, choice of data storage method at 6250 cpi; standard or Extra Capacity. Extra Capacity data storage at 6250 cpi increases DATA storage per tape (not BIT storage) by a factor of from two to five times.

Extra Capacity Data Storage (Option 400)

(NOT SUPPORTED ON DRIVES WITH THE PERTEC-COMPATIBLE INTERFACE.) With Option 400, Extra Capacity Data Storage, the 88780B not only writes and reads industry-standard 1600 PE and 6250 GCR densities, it is capable of increasing your data storage per tape by a factor of from two to five times.

The Extra Capacity format IS AN OPTION IN 6250 CPI DENSITY ONLY, and is known as 6250XC (6250 Extra Capacity).

How It's Done

The large increase in data storage per tape is achieved by

- 1) a combination of a sophisticated compression algorithm implemented in VLSI (Very Large Scale Integration) circuits and
- 2) an efficient utilization of the tape.

The compression algorithm –

The compression algorithm of Option 400, implemented in VLSI, recognizes repetitive data, whether this data is contiguous or appears intermittently throughout the total stream. The high-speed compression algorithm of Option 400 is much more than a simple replacement of multiple zeros or blanks with special code. The data compression operation adapts to the data. The algorithm of Option 400 is effective with any kind of data, as long as any pattern repeats—anywhere.

Instead of writing repetitive data to tape, a special code is assigned to each pattern of repeating data and this code is written to the tape instead. All writing to tape is done in industry-standard 6250 cpi GCR format.

Because the data compression algorithm of Option 400 is implemented in VLSI circuitry of the tape drive, all compression and decompression of the data occurs separate from the host.

When the tape is read back and the special, Extra Capacity format is encountered, the tape drive automatically expands the data and returns it to the host just as it was originally written. The host computer sees only what appears to be an extra-long 6250 cpi tape.

Any tape drive capable of reading 6250 GCR can read a tape created by an 88780B with Option 400 that used Extra Capacity (6250XC) storage. But because of the 6250XC codes embedded in the data, the host cannot interpret this data.

When the drive creates an Extra Capacity tape, it places a special, uncompressed header in the first block written on the tape. Any host can read this header and determine that the tape is an Extra Capacity tape.

Efficient use of the tape –

When writing in 6250XC format, the drive combines several blocks of incoming data into one “superblock” containing approximately 60 Kbytes of compressed data. Writing these large “superblocks” reduces the number of gaps needed on

a tape. Each length of tape saved by not turning it into a gap can now be filled with approximately 5 Kbytes of compressed data. Depending on file sizes and record sizes, the additional usable length of tape can be very significant.

The End Result The combination of compression and efficient utilization of the tape gives the Option 400 an extra tape capacity capability which is independent of the host's file size, and record size. Benchmarks on a wide variety of data indicate that HP 3000 (commercial system) tapes typically hold four to five times as much data as previously possible, and HP 9000 HP-UX (technical system) tapes hold approximately two to three times as much. The only variable which affects the ability to compress is the amount of repetition in the data. Text files, for example, can usually be compressed more than object code files because text data is generally more repetitive.

A standard (2400-ft) reel of tape at 6250 cpi density can hold approximately 140 megabytes of data. Extra Capacity (Option 400) can increase this amount to about 280-400 megabytes, depending on the data. If 3600-ft (1-mil) tapes are being used, the approximately 210 megabytes of available storage is increased to about 400-1000 megabytes (please see restrictions on using 1-mil tape in Appendix B).

Data Integrity The data integrity of the readback process in standard 6250 GCR is at least 100 Gigabytes of data per unrecoverable read error. Because a drive equipped with Option 400 writes data on less tape per backup, the chance of an error is much less. If an error were to occur however, it could involve more data because each block contains much more data than is contained in standard 6250 format. These factors cancel each other, and the 6250XC format has the same effective error rate as the standard 6250 format.

Suggested Tape Library Management The use of the extra capacity feature needs to be indicated on tape reels. The host does not recognize any difference between 6250 and 6250XC tapes. Tapes written in 6250XC must be read on an 88780B with Option 400 (or an HP 7980XC); if they are mounted on any other 6250-cpi-capable tape drive, the drive will recognize them as 6250 tapes, but it is very unlikely that the host will be able to process the data and will return an error message.

If a tape library is managed manually, the density should be marked as "6250XC" or "XC" on the tape label. If an automated tape library manager system is used, the marking should be entered into the comment field of the tape label generation program.

Some Questions and Answers About Using Data Compression

- Q. Why, when doing Extra Capacity writes or reads, does the drive start and stop more frequently than when doing non-compressed writes and reads?
- A. Compression/expansion occurs quickly and BEFORE the data reaches the 512-Kbyte buffer. When the tape stops streaming on a write, it shows that the host is unable to transfer bytes fast enough to keep the *effectively much larger* buffer filled and keep the tape streaming.

When the tape stops while reading, this shows that the host is unable to accept data as fast as drive buffer fills with data expanded from code on the tape.

-
- Q. Why does each Extra Capacity tape take longer to read or write than a non-data-compressed tape?
- A. Each tape contains much more data than previously possible. The time required to transfer a given amount of data to or from the host is approximately the same for an 88780B/Option 400 using Extra Capacity procedures and an 88780B reading or writing non-compressed data. When Extra Capacity procedures are used, the amount of data written or read back is from two to five times greater, so the time required (determined by the transfer rate) will be approximately two to five times greater.

Time savings are a result of reduced rewinds, tape loads and operator time.

- Q. Are tapes written in 6250XC readable on tape drives that do not have Extra Capacity capability?
- A. Other drives will recognize 6250XC tapes as 6250 GCR and be able to read the data back. But although this data is READABLE by the drive, it cannot be INTERPRETED by the host because the data remains in the compressed, Extra Capacity format.
- Q. Why is Extra Capacity not available for 1600 PE?
- A. The extra capacity feature is not available for 1600 PE because this density is most commonly used for interchange.

Ordering Options on the HP 88780B

HP 88780B – 1600/6250 cpi
Interface, accessories, mounting hardware, and cabinet are not included. An order must include an interface selection.

Order an interface by specifying Option 007 plus the Interface Kit desired (HP 88752A, 88754A, or 88755A).

The following options are available:

Option 007 – Interface Preparation

Provides both SCSI and Pertec-compatible interface firmware. The applicable firmware is mounted on the PCA included in the Interface Kit ordered with the drive (HP 88752A, 88754A, or 88755A).

Option 132 – Desktop Enclosure

Standalone cabinet for tape drive. Designed for desktop use. If ordered as an add-on, order HP 88706A described below.

Option 142 – Rotating Rack Slides

Rotating Rack Slides for mounting in a 19-inch rack enclosure. If ordered as an add-on, order HP 88709A Rotating Rack Slide Kit.

Option 400 – Data Compression (SCSI-interface drives only)

Adds data compression. Applies to 6250 GCR format only. Compressed 6250 density is called 6250XC (Extra Capacity).

Option 800 – 800 cpi NRZI

Adds 800 cpi density Non-Return to Zero Inverted (NRZI) format.
Not offered in kit form. Must be ordered with the drive.

HP 88752A Kit – Pertec-compatible Kit

Pertec Interface Kit. Includes Pertec-compatible interface PCA
and mounting hardware. Cables not included.

HP 88754A Kit – Single-Ended SCSI Kit

Single-Ended Small Computer Systems Interface (SCSI) Kit. Includes
Single-Ended SCSI Interface PCA and mounting hardware. Cables not
included.

HP 88755A Kit – Differential SCSI Kit

Differential Small Computer Systems Interface (SCSI) Kit. Includes
Differential SCSI Interface PCA and mounting hardware. Cables not
included.

HP 88706A Kit – Desktop Enclosure

Standalone cabinet. Designed for using the HP 88780B on a desktop.

HP 88709A – Rack Slide Kit

Rotating Rack Slide Kit for the HP 88780B.

2

Operation

This chapter is divided into two sections: **Quick Start** and **Procedures**.

■ **Quick Start** offers few details and explanations and is placed here as a reference for experienced operators.

■ **Procedures** offers a detailed review of the drive's operation, providing complete instructions and explanations. Tasks you perform less frequently, such as enabling specific features, are described in Appendix A.



Some operations required specific options to be installed in the drive. Option 400 enables the drive to store data in an "Extra Capacity" format (6250XC), Option 800 enables the drive to read and write in 800 cpi NRZI format. These options are specified in the text where they apply.

To start the drive for the first time, use the "Procedures" section of this Chapter. If your drive has Option 400, Extra Capacity, read "Extra Capacity Data Storage (Option 400)" in Chapter 1 before operating the drive.

Quick Start

These instructions are a reminder of the basic loading procedure. It is assumed here that the drive is "active": configured, connected to power, and the rear panel Main AC Power Switch is ON.

1. Press IN the **Standby Switch** on the lower left of the front panel. When the drive passes selftests, *READY* appears in the display.

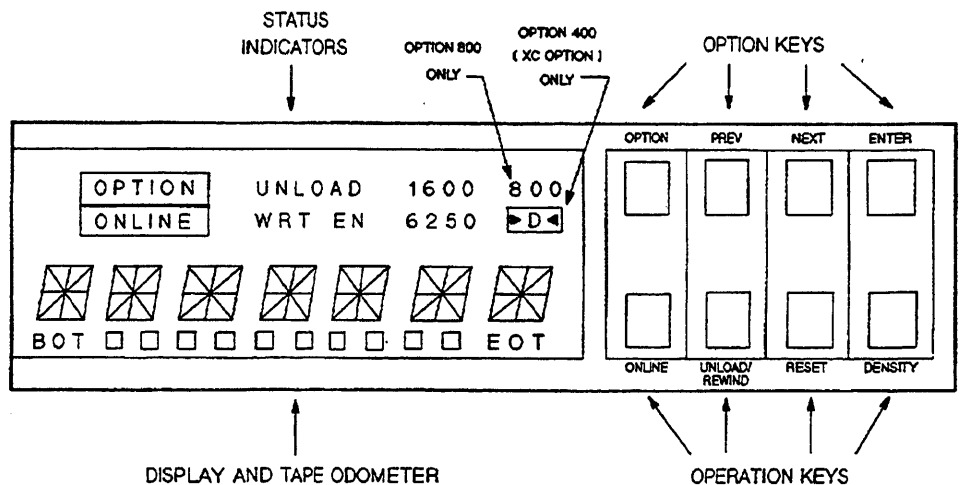

Control Panel

2. Set the write density, if required.
3. Press the **UNLOAD** key to open the tape door.
4. Slide a tape through the tape path door, making sure the loose end of the tape is on the right and is not caught under the reel.
5. Close the tape path door.
The drive begins the **LOADing** sequence.
6. Press **ONLINE** (if the drive is not configured for Auto Online).

O p e r a t i o n O p t i o n I n d i c a t o r s	K e y s	ONLINE UNLOAD/ REWIND RESET DENSITY	Selects ONLINE or OFFLINE . Toggle key. One press - rewinds tape to BOT . Two presses - rewinds tape to BOT and UNLOADs tape. Aborts an operation. Selects write density.
	K e y s	OPTION PREV NEXT ENTER	Enters or exits the OPTION select mode. Displays the previous OPTION choice. Displays the next OPTION choice. Selects the displayed OPTION and choices within the OPTION .
	I n d i c a t o r s	OPTION ONLINE UNLOAD WRT EN 800 1600 6250 >D< TAPE ODOMETER	Lit when OPTION mode is selected. Lit when the drive is ONLINE . Flashes if the ONLINE command is queued. Lit when an UNLOAD operation is in progress. Flashes if the UNLOAD command is queued. Lit when a write-enabled tape is loaded into the drive. Remains on until tape is UNLOADed . Lit when a 800 cpi write density is selected (Option 800 required). Lit when a 1600 cpi write density is selected. Lit when a 6250 cpi write density is selected. Lit when a 6250 write density with Extra Capacity is selected (Option 400 required). Segments show the relative position of the tape between the Beginning of Tape (BOT) and the End of Tape (EOT).

Control Panel Keys and Indicator
(Quick Reference to Basic Functions)

Procedures

The following sections describe drive operations in more detail and are especially useful for first-time start-up. A full explanation of the Control Panel keys, status indicators, and display messages is at the end of this Chapter, after these procedures.

NOTE  If you have a drive capable of Extra Capacity storage (has Option 400), please read "Extra Capacity Data Storage (Option 400)" in Chapter 1, before reading these operational procedures.

Power on After the drive has been installed, follow these steps:

NOTE  When transferring the tape drive from a very cold environment to a warm environment, or vice versa, it is very important to let the drive adapt to the new conditions to obtain maximum autoloader performance.

Apply power to the drive for at least one hour before autoloading (**Main AC Power Switch** on the rear panel "1", **Standby Switch** on the front panel IN—see next NOTE). If the new environment is extremely humid or cold, allow at least two hours.

Tapes should also be acclimatized. Remove storage rings or cases and let the tapes set for at least one hour. If extremely humid or cold, allow at least two hours. This procedure allows temperatures to equalize and allows the tapes to dry out sufficiently to insure optimum autoloading.

For optimum read/write performance, allow the tapes to acclimate for 24 hours. This provides enough time for the tape humidity to equalize with that of the environment.

NOTE  Two switches must be in the ON position to operate the drive; the **Main AC Power Switch**, located on the rear panel of the drive unit, and the **Standby Switch**, located on the lower left of the front panel.

The **Main AC Power Switch** controls input power to the drive and should remain ON continuously during normal operations. The **Standby Switch** allows input power to be passed to the electronics of the drive (and should also remain ON as much as possible to gain maximum life from the electronics).

After installation, all that is normally necessary is to start at Step 3 below. Steps 1 and 2 are here in case power is removed from the drive.

-
1. Make sure the **Standby Switch** on the lower left of the front panel is out (OFF). This is a toggle IN/OUT switch.
 2. On the rear panel of the drive unit, press the top of the **Main AC Power Switch** ("1" on the rocker switch) to apply power.
 3. Make sure the tape door is closed.
-

NOTE



INITIAL STARTUP

These steps assume the drive is being started up FOR THE FIRST TIME. We will cycle the drive to a point where, if a tape had been loaded, normal interaction with the host could begin.

After this initial checkout, you will insert a tape and enter an explanation of normal operating procedures.

4. Press the **Standby Switch** on the lower left of the front panel IN (ON).

If no display is obtained when both switches are in the correct position, refer to Chapter 3, "Control Panel Lights Do Not Come On."

NOTE



If you have a drive capable of Extra Capacity storage (has Option 400), please read "Extra Capacity Data Storage (Option 400)" in Chapter 1, before reading these operational procedures.

When the drive is powered up, **TESTING** and then *TESTING* appears in the Control Panel display. As the drive runs through the poweron sequence of tests, all lights on the panel are individually flashed.

When the drive passes selftest, the *READY*** message appears in the display. This message means that the drive is ready to load a tape or to accept commands from the Control Panel.

***Depending on the selection made in the Language Configuration (48), the initial message will be READY, NO TAPE, or UNIT #. See Appendix A, "Configurations", Language Configuration (48) for more information on your display options.*

Loading Tape

NOTE



The 88780B can accept 1-mil tape (3600-foot reels). But before using this thickness of tape, please review "Using 1-Mil Tape" in Appendix B.

NOTE



Prevent Edge Damage!

Use care when handling the tape reels. If reels are gripped in any way that presses the flanges together, there is a possibility of damaging the edge of the tape.

The hub is the strongest, least flexible portion of the reel. **ALWAYS HOLD THE TAPE REEL BY THE HUB OR AS CLOSE TO THE HUB AS POSSIBLE.**

There is a greater danger of mishandling tape reels when using a horizontal-mount tape drive. The figure on the right below shows how a reel could be held in a horizontal position with one hand without pressing the flanges together.

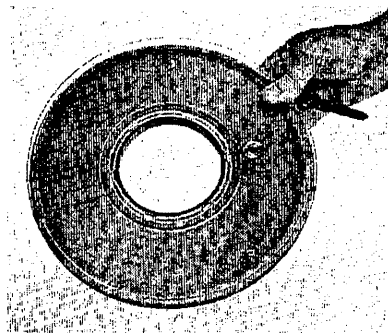

NO

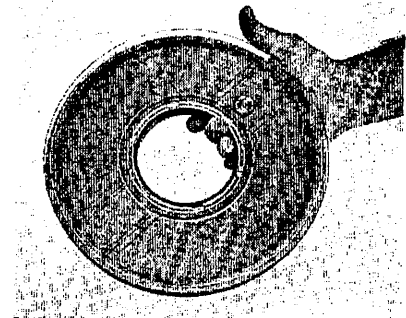

YES

NOTE



- a) For consistent, optimum tape performance, the end of the of the tape should be rounded and crimped. (Most new tapes come from the manufacturer with the tape end prepared this way.)

Autoloading should not be affected by small folds or irregularities in the last couple of feet of the leader, but if the leader has folds that run lengthwise along the tape or if that portion is definitely “crumpled”, you should cut that part of the tape off. For best results use a tool made for this purpose—like the tape cutter/crimper from Pericomp Corporation.

If the end of the tape is damaged, cut off only what is necessary to remove the damage.

To ensure that the tape can be loaded on any drive that conforms to ANSI standards, do not shorten the tape leader to less than 14 feet. (The tape leader is the portion of tape between the physical end of the tape and the BOT Marker.)

- b) Ensure that the tape end is free to move.
-

-
5. Check for tape write-enable capability, as desired.

Write-enable rings are installed on the back of a tape reel. When these rings are in place, you may record data on the tape. To PROTECT data from being over-written, REMOVE THE RING. You may then read data from the tape but are prevented from writing to the tape.

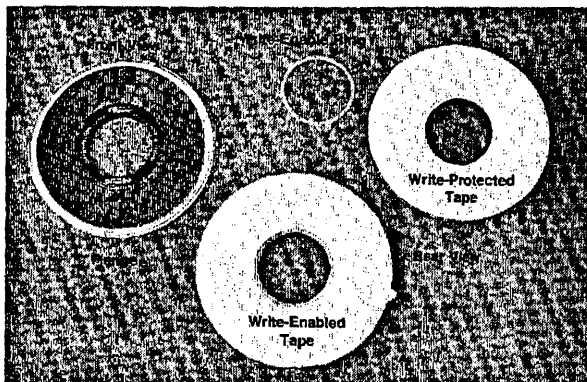

Write-Enabled and Write-Protected Tapes

6. Press the UNLOAD/REWIND Key to open the tape path door.

CAUTION



Always press the UNLOAD/REWIND Key to open the door or to stop a LOAD operation. **Do not try to force the tape door open.**

NOTE



Reminder—

If the tapes you are going to use have recently been stored in a place that had a much different temperature and/or humidity level, the tapes should be acclimatized before use. Remove storage rings or cases and let the tapes set for at least one hour. If the difference in environments is “extreme”, allow at least two hours. This procedure allows temperatures to equalize and allows the tapes to dry out sufficiently to insure optimum autoloading.

For optimum read/write performance, allow the tapes to acclimate for 24 hours. This provides enough time for the tape humidity to equalize with that of the environment.

7. Slide a tape, free end to the right, into the center of the tape door opening. If inserting a small tape, it is best to insert the tape either to the center or a little to the right of center of the tape door.

Make sure the tape leader is free on the right side of the reel, not trapped under the reel or by the tape path door.

8. Close the tape path door.

Closing the door initiates the next part of the sequence.

NOTE



—The operator will see *LOADING* appear in the display.

When the drive senses a tape, the supply hub rotates to center the reel on the hub. Once the reel is correctly seated, the hub locks the reel. The autoloader blower then turns on and blows the tape end off the supply reel as the supply motor feeds the tape out into the path. While the blower is on, the drive searches for the free tape end.

When the tape end is found, the blower blows the tape through the tape path with the supply motor feeding out tape. The tape is sucked onto the rotating take-up reel until the sensor detects tape motion. The drive then properly tensions the tape and advances the tape to the BOT marker. The density of the tape is determined.

—The operator will see the density of the tape in the display (*800, 1600, 6250, BLANK, or UNKNOWN*). To detect and show the 800 cpi density, Option 800 must be installed.

—The operator will then see *BOT* in the display.

If the autoloader operation fails (no error message given), try the above steps two or three times. If it continues to fail, refer to “Tape Does Not Autoload” in Chapter 3.

If the autoloader operation fails and you see *NO BOT* in the display, refer to “BOT/EOT Markers Must Be Replaced” in Chapter 3.

9. Set the write density, if required.

NOTE



If the drive is configured to execute Auto Online immediately after *LOADING* tape (Configuration 41 set to ON), the drive must be brought offline before tape density can be set. Press the **ONLINE** Key to bring the drive offline (this key toggles the drive between **ONLINE** and **OFFLINE**).

An explanation of configurations, their default settings, and how you may change these settings is in Appendix A, “Configurations.”

Density may be set either before the tape is loaded (*READY, NO TAPE, or UNIT #* displayed - see Language Configuration (48) in Appendix A, “Configurations”), or after the tape is loaded and *BOT* is showing in the display. In both cases, the drive must be **OFFLINE**.

a) Press the **DENSITY** Key.

The message *DENSITY* appears in the display and the density indicator light for the current, selected density comes on (800, 1600, 6250, or 6250 along with the >D< INDICATOR).

Option 400 must be installed for the >D< INDICATOR to light. Option 800 must be installed for the 800 INDICATOR to light. This applies in the next step also.

b) Press the **DENSITY** Key again to light the desired density indicator.

Each keypress lights the next indicator, in turn. The sequence is: 1600, 6250, 6250 with the >D< INDICATOR (means 6250XC), and then 800.

c) Press **ONLINE**.

The drive selects the density of the density indicator currently lit.

If the **DENSITY** Key is not pressed within approximately five seconds, the drive automatically selects the density shown by the density indicator currently lit. The *DENSITY* message goes off.

10. Press **ONLINE**. (If not pressed during Density Selection.)

You may press the **ONLINE** Key anytime after closing the door. You may queue the command to go **ONLINE** immediately after closing the door or wait until the drive finds the BOT marker.

You would press the **ONLINE** Key immediately after closing the door if either 1) you knew that the current selection for write density was correct for your next write operation or 2) write density was not a concern for you at that time (i.e. you were only going to read a tape, not write).

If you press **ONLINE** *before* loading has finished, the **ONLINE** INDICATOR flashes and the drive waits to go **ONLINE** until loading is finished.

If you press **ONLINE** *after* loading has finished, the drive goes **ONLINE**.

When the drive goes **ONLINE** the displays and indicators are as follows:

- the **ONLINE** INDICATOR remains lit
- the **TAPE DENSITY** INDICATOR remains lit and shows the current selection for write density.

Option 800 is required to use and display 800 cpi density, Option 400 is required to use and display 6250 cpi density with Extra Capacity ability (i.e. light the >D< INDICATOR).

- the **WRITE-ENABLE STATUS** INDICATOR remains lit and shows the write enable/disable status of the tape

– the message in the display generally corresponds to the command the host is currently sending to the tape drive.

Unloading Tape

1. Take the drive offline by pressing **ONLINE**.
2. Press the **UNLOAD/REWIND** Key. The drive **UNLOADS** the tape and opens the tape door.
3. Remove the tape.

The Control Panel

The Control Panel allows the operator to select operating, diagnostic, addressing, and configuring functions.

During normal operation, you will use the four **OPERATION KEYS** located on the bottom row of the Control Panel. You will select other functions using the **OPTION KEYS** on the top row. The **STATUS INDICATORS** do just that — indicate the status of the drive.

Operation, option, and error messages appear in the seven-character display under the **STATUS INDICATORS**. A tape odometer that shows the relative position of the tape during operation is located under this display.

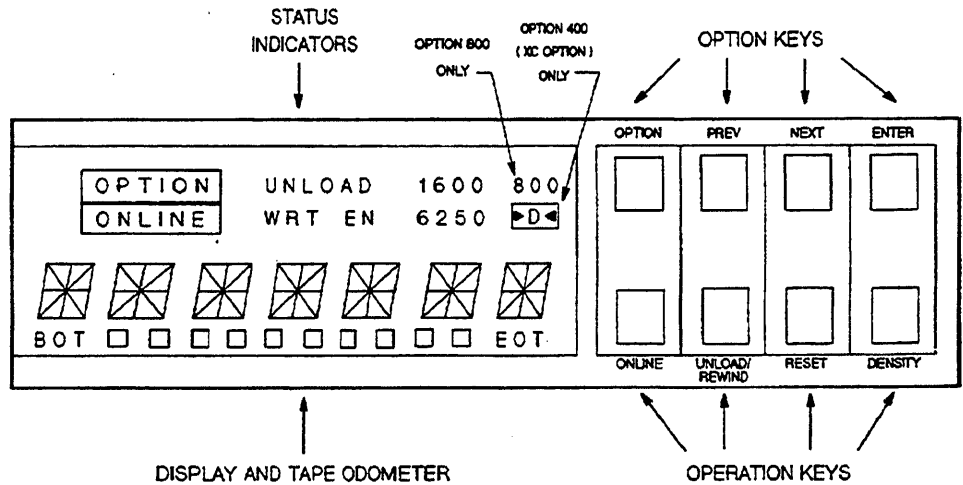

Control Panel

The following list describes the purpose and response of each key and indicator:

OPERATION KEYS **ONLINE.** A toggle key that selects either ONLINE or OFFLINE operation of the drive. When the drive is ONLINE, it can accept and execute commands from the host. When the drive is OFFLINE, only local commands from the Control Panel can be executed.

The ONLINE STATUS INDICATOR lights when the drive goes ONLINE.

The ONLINE command may be queued; that is, you may press the key before the command can be performed, and the drive waits until the current operation is finished before going ONLINE. To indicate that the command is queued, the ONLINE STATUS INDICATOR flashes.

You may cancel a queued ONLINE command by pressing the ONLINE Key a second time.

UNLOAD/REWIND. If a tape is between BOT and EOT and the drive is OFFLINE with the tape door closed, pressing this key *once* positions the tape at BOT.

When the BOT Marker is reached, "BOT" appears in the display.

Pressing the key *twice* (before the tape has rewound to BOT), initiates the REWIND sequence and queues the UNLOAD command. The tape continues past BOT, UNLOADs, and the tape door opens.

If the tape is at BOT when the UNLOAD/REWIND Key is pressed, the tape UNLOADs and the tape door opens.

If no tape is in the drive, the door opens immediately when this key is pressed.

This key is inoperative if the drive is ONLINE or if the tape door is open.

RESET. RESET aborts operations; both those from the Control Panel and those under control of the host (if *BUSY* is being displayed).

CAUTION



Pressing the RESET Key while *BUSY* is displayed causes the data in the drive buffer to be lost.

If the RESET Key is pressed during a tape LOAD, the LOAD will be aborted — the tape door remains closed.

While in OPTION mode, pressing RESET backs up the selection process (and display) to the previous level.

DENSITY. Used to change the write density.

This key is active before a tape is loaded or when a loaded tape is at BOT and the drive is OFFLINE. When pressed, *DENSITY* appears in the display (the density indicator corresponding to the current density selection is already on). (The density indicators which may be lit depend on the Options installed in the drive.)

The *DENSITY* Key can be used to change the write density entered into the drive only while the *DENSITY* message is in the display.

While *DENSITY* is in the display, repeatedly pressing the *DENSITY* Key causes the next density indicator, in turn, to flash.

If the *ONLINE* Key not pressed within four seconds (to "enter" the density shown by the current flashing indicator) or if the *DENSITY* Key is not pressed again to select a different density choice, the drive automatically accepts the density shown by the currently-lit density indicator.

OPTION KEYS **OPTION.** *OPTION* activates the Option mode, lights the *OPTION INDICATOR*, and disables the Operation Keys.

While in this mode, you may select options of *TEST*, *CONFIguration*, *INFORmation*, or *ADDRess* (or *ID*).

Pressing the *OPTION* Key while in any state except running a test or within the *INFO* display, returns the drive to normal, *OFFLINE* operation.

PREV. Pressing *PREV* decrements the number in the display or returns to the previous option.

NEXT. Pressing *NEXT* increments the number in the display or advances to the next option.

ENTER. Selects the *OPTION* currently shown in the display (*TEST*, *CONFIguration*, *INFORmation*, *ADDRess/ID*).

Once an *OPTION* is selected, the *NEXT* and *PREV* Keys are used to step through possible values for that *OPTION* and the *ENTER* Key is used to select the value.

STATUS INDICATORS

OPTION. The OPTION INDICATOR is lit when the drive is in OPTION mode and remains lit while you are accessing a particular option.

The OPTION INDICATOR turns off if you press the OPTION Key a second time.

ONLINE. The ONLINE INDICATOR remains on while the drive is ONLINE. This indicator flashes if the ONLINE command is in a queued state; caused by pressing the ONLINE Key immediately after starting a LOAD sequence. When the LOAD sequence is finished, the drive will automatically go ONLINE and the ONLINE INDICATOR will remain on continuously.

The ONLINE INDICATOR turns off when you place the drive OFFLINE by pressing the ONLINE Key second time.

UNLOAD. Lights when an UNLOAD operation is in progress. Goes out after the tape door opens in the UNLOAD sequence; *UNLOAD* appears in the display.

This indicator flashes if the UNLOAD command is queued (the UNLOAD/REWIND Key was pressed immediately after pressing the UNLOAD/REWIND Key).

WRT EN. The WRT EN (Write-Enable) INDICATOR lights, and remains on, when a tape with a write-enable ring is LOADED into the drive.

The WRT EN INDICATOR turns off when the write-enabled tape is UNLOADED.

800. (Option 800 required) Continually lit to show that a 800 cpi write density has been selected.

During the density selection process, this indicator is flashed to show that 800 cpi density was selected.

1600. Continually lit to show that a 1600 cpi write density has been selected.

During the density selection process, this indicator is flashed to show that 1600 cpi density was selected.

6250. Continually lit to show that a 6250 cpi write density has been selected.

During the density selection process, this indicator is flashed to show that 6250 cpi density was selected.

This indicator is used along with the **»D«** INDICATOR to show 6250XC selection. See description of the **»D«** INDICATOR below.

»D«. (Option 400 required) Continually lit to show that a 6250 cpi write density using Extra Capacity data storage procedures has been selected.

During the density selection process, this indicator, when flashed along with the 6250 INDICATOR described above, shows that 6250XC (Extra Capacity) was selected.

TAPE ODOMETER. Located under the seven-character display, the ODOMETER odometer consists of the BOT reference, a row of fluorescent segments, and an EOT reference. This display shows the relative position of the tape during operation.

The following list describes the messages and prompts which you may see in the display.

MESSAGES



A question mark at the end of the message description means that the message is a prompt; what is shown in the display will be selected if the ENTER Key is pressed.

MESSAGES DURING NORMAL OPERATION

XXXXXXXX The drive is powering up. All segments of all digits light.

TESTING Displayed during poweron selftest sequence.

LOADING The drive is **LOADING** a tape.

UNLOAD The drive is **UNLOADING** a tape.

READING The host is reading data from the tape.

RETRY The drive is retrying an operation.

WRITING The host is writing data to the tape.

REWIND The drive is **REWINDING** tape.

RESET The drive is **RESETTING** (commanded from either the Control Panel or the host).

DENSITY The drive is waiting for a density selection from the front panel.

6250 The tape **LOADED** into the drive has a density of 6250 cpi.

1600 The tape **LOADED** into the drive has a density of 1600 cpi.

800 The tape **LOADED** into the drive has a density of 800 cpi. (Requires Option 800.)

BLANK The tape **LOADED** into the drive is blank.

UNKNOWN A tape of unknown density was **LOADED**.

WARNING AND ERROR MESSAGES

<i>BUSY</i>	The drive is completing commands from the host. This display appears if the ONLINE or RESET Key is pressed while the drive is completing host commands.
<i>WAIT</i>	The drive is waiting for the interface to complete a request from the host. This message is displayed briefly.
<i>ONLINE</i>	A keypress on the front panel was received but cannot be accepted because the drive is ONLINE.
<i>INVALID</i>	The keypress received from the Control Panel cannot be executed in the present mode.
<i>DISABLE</i>	The host has disabled capability to remove the tape from the drive (SCSI only).
<i>MISLOAD</i>	An attempt to LOAD a tape failed.
<i>NO BOT</i>	The drive could not find a Beginning-of-Tape (BOT) Marker.
<i>INVERT</i>	The tape was inserted upside down.
<i>DOOR</i>	The tape door or the top cover has been opened. This message is displayed if a front panel operation is attempted.

IDLE OPERATION AND TAPE POSITION MESSAGES

<i>READY</i>	The drive is ready to accept commands or LOAD a tape. Whether this phrase or one of the next two phrases (NO TAPE or UNIT #) appears in the display depends on the values stored in the Language Configuration (48). See NO TAPE and UNIT # described below.
<i>NO TAPE</i>	This message may be used instead of the READY message. See Appendix A, "Configurations", Language Configuration (48).
<i>UNIT #</i>	The "#" is the current bus address or ID. This message may be used instead of the READY message. See Appendix A, "Configurations", Language Configuration (48).
<i>BOT</i>	The tape is at the Beginning-of-Tape (BOT) Marker and is ready to accept commands.
<i>EOT</i>	The tape is beyond the End-of-Tape (EOT) Marker.
[]	The drive is waiting for a command. The tape is between BOT and EOT (but not at either one). If a command is not received in five seconds, the display changes to "IDLE" (see the next message description). This is not an error message.

-
- IDLE* The drive is waiting for a command. The tape is between BOT and EOT (but not at either one) and a command has not been received in the last five seconds. This is not an error message.
- CHECK* An excessive "soft" error rate has been detected by the drive. A "soft" error is anything that causes the drive to retry reading or writing a record. This message usually indicates that the tape path and head should be cleaned.

MESSAGES WHEN ENTERING OPTION SELECTION

- TEST** Selecting TEST Option?
- CONF** Selecting CONFIGURATION Option?
- INFO** Selecting INFORMATION Option?
- ADDR** Selecting Pertec-Compatible Interface ADDRESS number?
- ID** Selecting SCSI Interface Bus ID number?

MESSAGES WHEN WITHIN OPTIONS

- TEST###* Selecting Test <###>? (### = test number)
- CONF###* Selecting Configuration <###>? (### = configuration number)
- INFO###* Selecting Information <###>? (### = information number)
- SET ###* Configuration has been set to <###>.
- SET OFF* Configuration has been set to OFF.
- ADR OFF* PERTEC-compatible interface is set to OFF.
- ID OFF* SCSI interface is set to OFF.

MESSAGES WHEN WITHIN TEST OPTION MODE

- ONCE** Run the selected test once?
- 10** Run the selected test 10 times?
- 100** Run the selected test 100 times?
- 1000** Run the selected test 1000 times?
- ⋮
- LOOP** Run the selected test until an error or until stopped by the operator?
- RUN ###* The drive is executing Test <###>. (### = test number)
- PASS###* Test <###> passed. (### = test number)

FAIL### Test <###> failed. (### = test number)



YOU SHOULD NOT SEE THE NEXT FOUR MESSAGES DURING NORMAL OPERATIONAL USE. These prompts appear during selection of diagnostic tests that should only be executed by trained service personnel. See Chapter 3, "Troubleshooting and Diagnostics" for descriptions of the tests available to all operators.

Press **RESET** at least two times to return to the *TEST <###>* display. If you were not attempting to run a test, press **RESET** one more time to return to the *TEST ** display (which is the Option Select level). Then use the **NEXT** or **PREV** Keys to select the desired Option.

A ##### Selecting parameter A <#####>? (##### = selected value)

B ##### Selecting parameter B <#####>? (##### = selected value)

C ##### Selecting parameter C <#####>? (##### = selected value)

SEQ39 User-defined sequence of tests is being defined.

MESSAGES DURING DIAGNOSTICS

OPTION OPTION Key name.

[] ENTER Key name.

NEXT NEXT Key name.

PREV PREVIOUS Key name.

BOTEOT BOT EOT sensor test message.

* Sensor seen.

*KEY** Key test.

CONFIGURATION VALUE MESSAGES

** Configuration value is unknown.

OFF Select Configuration value of "OFF"?

ON Select Configuration value of "ON"?

<i>###</i>	Select Configuration number value of <###>?
<i>CLEAR</i>	Select Configuration value of "CLEAR"?
<i>SAVE</i>	Select Configuration value of "SAVE"?
<i>HOST</i>	Select Configuration value of "HOST"?
<i>REW*</i>	Select normal, high-speed rewind?
<i>ATC*</i>	Select Archival Tape Conditioning rewind?

3

Troubleshooting and Diagnostics

Overview

This chapter describes some problems you may encounter during operation and also offers steps to solve those problems.

This chapter also describes diagnostics you may use as confidence tests. Most of the drive's diagnostics, however, are useful only to service personnel. **You should not run any tests other than those described here.**

CAUTION



If you see an error code not described here, call your nearest authorized Hewlett-Packard Distributor. If you run a test not described in this Guide, you risk losing data or changing the characteristics of the tape drive.

Error Messages

Error messages can occur in three situations:

- at poweron, when the drive runs a series of diagnostics,
- after you run a diagnostic test from the Control Panel, and
- during normal operation.

You can respond to many of the messages which occur from the poweron and other diagnostic tests. You cannot respond to some runtime errors however, because the tape drive only notifies the host of these errors and may continue running. Anytime an error occurs, the error is entered into an error log maintained by the drive. If the error is caused by a hardware failure, the error is reported to the host.

The following chart lists error messages you may see on the Control Panel display and the steps to take when you see them.

	MESSAGES	ACTION
T E S T	RUN <###>	Test <###> is running. No action necessary.
	PASS <###>	Test <###> has passed. No action necessary.
	FAIL <###>	Test <###> has failed. Press ENTER to display error code.
	ERR 01	Test needs a tape to execute. Mount tape.
	ERR 04	Tape is write protected. Remove write-enable ring or use a new scratch tape.
	ERR 06	Close top cover.
	ERR 20 ERR 31 ERR <###>	Select valid test number. Wait until system is available. Call Hewlett-Packard distributor.
O P E R A T I O N	MISLOAD	Follow tape loading steps in Chapter 2. If message persists, read "Tape Does Not Autoload" in Chapter 3.
	BUSY	Drive completing online functions. No action necessary. Pressing RESET aborts host operations but may cause data loss. This indication stops when host is finished.
	INVALID	Select valid key. Chapter 2 explains the functions of the keys.
	NO BOT	UNLOAD tape and manually check for proper location and placement of the BOT marker. Refer to "BOT/EOT Markers Must Be Replaced" at the end of Chapter 3.
	CHECK	Excessive soft error rate. Clean the tape path. Tape path cleaning procedures are in Chapter 4.

Error Messages and Actions

Displaying the Error Logs

A number of logs are maintained by the drive. These logs contain errors detected during operation, drive performance information, drive usage information, and various other statistics.

THESE LOGS ARE PRIMARILY FOR THE USE OF TRAINED SERVICE PERSONNEL, but you may be asked to access the log(s) at some time to retrieve information (possibly prior to a service call).

To display the error log(s), follow these steps:

1. Take the drive OFFLINE (press the ONLINE key, if necessary).
2. Press OPTION. TEST * appears in the display.
3. Press NEXT twice to bring INFO * into the display.
4. Press ENTER. The display will show INFO 0.

This log contains the last 30 errors that occurred during operation of the drive.

5. If this is *not* the log you want, go to Step 7. If this *is* the log you want, press **ENTER** again to begin showing the information.

6. Step through the entries as necessary.**

Pressing **NEXT increments the log entry by 1, pressing **PREV** decrements the log entry by 1.

The first digit of the error code in the log entry indicates the order in which the errors occurred (e.g. *E01*, *E02*, etc.). The *greater* the number in the log, the *more recent* the error.

7. If you are requested to read a different log than Log 0 (*INFO 0* is in the display), bring that **INFO** number into the display.**

Pressing **NEXT increments the number by 1, pressing **PREV** decrements the number by 1. Pressing the lower right key on the panel, the **DENSITY** Key, increments the number by 10s, pressing the lower left key on the panel, the **ONLINE** Key, decrements the number by 10s.

8. Press **ENTER** to begin showing the information.**

Pressing **NEXT increments the log entry by 1, pressing **PREV** decrements the log entry by 1.

The first digit of the error code in the log entry indicates the order in which the errors occurred (e.g. *E01*, *E02*, etc.). The *greater* the number in the log, the *more recent* the error.

9. When finished reading the log(s), press **ENTER**. The display returns to *INFO **.

10. Press **OPTION** or **RESET** to leave Option mode.

Internal Diagnostics

Two sets of diagnostic tests are available to the operator; a series of power on selftests and a series of confidence tests.

If a test fails, check the chart in the front of this chapter. If the error is not listed in the chart notify your nearest authorized Hewlett-Packard Distributor.

CAUTION



Execute ONLY the tests described in this Guide. Take care when you are selecting test numbers. Some tests will overwrite data on the tape.

Available Tests **TEST 0** calls all poweron diagnostics. Run automatically at poweron or manually by the operator, **TEST 0** calls a sequence of tests that checks all data paths and normal machine operation. **TEST 0** also sequences through all the Control Panel lights and indicators. This test should take no more than 45 seconds.

CAUTION



You must use a write-enabled "scratch" tape for the next test, **TEST 1**. The test overwrites any data on the tape.

TEST 1 completely checks out the drive. The test first runs all poweron tests, then loads a tape and checks out all sensors. The test causes a write to EOT, a rewind, and then a read from the tape at each of the densities your drive is capable of writing. On a 2400-ft tape, with 800, 1600, and 6250 cpi densities, this test takes about 35 minutes.

TEST 70 lights all of the Control Panel indicators and displays.

TEST 71 tests the keys on the Control Panel. The name of each key is displayed for one second after that key is pressed. The test is terminated by pressing **RESET** twice.

TEST 72 is an interactive test that checks control panel functions. After selecting this diagnostic, press the keys in the following order:

1. **OPTION** This function is tested by selecting the next language in Configuration 48. The Tape Odometer shows the languages as positions on the left end of the row of indicators. Repeatedly pressing the **OPTION** Key cycles the selection through **ENGLISH** (no light), **GERMAN** (one light), **FRENCH** (two lights), and **SPANISH** (three lights).
2. **PREV** This function is tested by selecting the display message stored in memory that "precedes" the message currently in the display. Repeatedly pressing this key steps "backwards" through the available list of messages in the current language.
3. **NEXT** This function is tested by selecting the display message stored in memory that "follow" the message currently in the display. Repeatedly pressing this key steps "forward" through the available list of messages in the current language.
4. **ONLINE** Resets the message pointer back to the first message shown when this test was started.
5. **ENTER** or **RESET** Stops **TEST 72**.

Running Tests To run a diagnostic test, follow these steps. **TEST 1**, "General Checkout" is used as an example:

1. Insert a write-enabled "scratch" tape.
2. Close the tape door.
3. After the drive positions the tape at BOT, take the drive OFFLINE (press ONLINE, if necessary).
4. Press **OPTION**. *TEST ** appears in the display.
5. Press **ENTER**.
6. Bring the test number you want into the display.

For this example, *TEST 1*, press the **NEXT** key once to bring "1" into the display. If you go past the number "1", press **PREV** to decrement the number.

When selecting tests with much higher numbers (e.g., Test 72), you may want to use the **DENSITY** key to increment the display by 10s or the **ONLINE** key to decrement the display by 10s until you get close to the number and then use the **NEXT** or **PREV** key to increment or decrement the display to the proper units digit.

7. Press **ENTER**.
8. The display prompts *ONCE **, asking you if you want the test to be run only once.

If you would like to run the test more than once (perhaps checking for intermittent problems), use **NEXT** and **PREV** to display your other choices. Your other choices are: 10 times, 100 times, 1000 times, or **LOOP** (run continuously until **RESET** is pressed).

9. Press **ENTER** to run the test.

The drive displays *RUN <test number>*, indicating which individual test in the sequence is running. (These individual tests are not described in this Guide because they have meaning only for those trained to service this product. You will want to know only if the sequence completes successfully or not.)

10. When the test is over, either *PASS <test number>* or *FAIL <test number>* is displayed.

If the test passed and you want to repeat the test or to select another test, press **ENTER** or **RESET**. The display will return to the level that displays the test number (in this case it will display *TEST 1*).

If you want to select the same test, press **ENTER** and then repeat Steps 8 and 9.

If you want to select another test, use the **NEXT** and **PREV** keys (and/or the **DENSITY** and **ONLINE** keys to select the test number.**

Pressing **NEXT increments the number by 1, pressing **PREV** decrements the number by 1. Pressing the lower right key on the panel, the **DENSITY** key, increments the number by 10s, pressing the lower left key on the panel, the **ONLINE** key, decrements the number by 10s.

11. If the test fails, press **ENTER** to display the error that caused the failure. If you cannot find the error listed in the chart in the front of this chapter, call your nearest authorized Hewlett-Packard Distributor. Press **RESET** three times to completely exit through the test selection and Option Select levels.
12. To abort a test (*TEST 1* in this case), press **RESET**. Press **RESET** one more time to come back to the Option Select level (*TEST ** appears in the display).
13. Press **OPTION** or **RESET** to leave Option Mode.

Other Corrective Actions

Tape Does Not Autoload

Not all problems are diagnostic failures or result in Control Panel messages. Follow these guidelines when something out of the ordinary occurs.

If the drive is having difficulty **LOADing** a tape and you are seeing a *NO BOT* message, go to the end of this Chapter to "**BOT/EOT Markers Must Be Replaced.**"

If you do not see *NO BOT* in the display, begin by reading the following **NOTE** and then, if necessary, do the steps that follow the **NOTE**.

NOTE



When transferring the tape drive from a very cold environment to a warm environment, or vice versa, it is very important to let the drive adapt to the new conditions to obtain maximum autoload performance.

Apply power to the drive for at least one hour before autoloading (**Main AC Power Switch** on the rear panel to "1", **Standby Switch** on the front panel IN). If the new environment is extremely humid or cold, allow at least two hours.

Tapes should also be acclimatized. Remove storage rings or cases and let the tapes set for at least one hour. If extremely humid or cold, allow at least two hours. This procedure allows temperatures to equalize and allows the tapes to dry out sufficiently to insure optimum autoloading.

IF A CHANGE IN ENVIRONMENT DOES NOT SEEM TO BE THE PROBLEM:

1. Press **UNLOAD** to release the tape and open the door. Remove the tape.

-
2. (If the drive is mounted on rails in a cabinet)—pull the release handle on the bottom middle of the front panel to release the drive, then slide the drive out on its rails until the rail lock buttons snap into position.
 3. Lift the top cover.
 4. Clear any debris off the tape path. If the tape progressed to the takeup reel hub during the LOAD sequence but did not attach to the hub, check to see that the small air inlet holes on the hub are not blocked by debris.
 5. Close the top cover.
 6. Cut off any wrinkled tape from the end of the tape leader. Use a tape crimper (like the one from Pericomp Corporation) to ensure that the end of the tape is cut, crimped and rounded properly. Ensure that the tape that is cut off does not contain the BOT Marker. If the BOT Marker must be cut off, go to "BOT/EOT Markers Must Be Replaced" at the end of this chapter.
 7. Slide the tape reel in—place the reel in the center or to the right of the tape path opening. (If you insert the reel in to the left, the supply hub cannot always find the reel.)

Make sure the tape leader is free on the right side of the reel; not trapped or pinched by the reel or by the tape path door.

8. Close the tape door. A LOAD sequence begins automatically.

If the tape does not autoloading, try removing and re-inserting the tape a couple of times. If the drive still does not autoloading, you may manually LOAD the tape using the following steps. Also, contact your nearest authorized Hewlett-Packard Distributor.

MANUAL TAPE THREADING (see the following figure):

9. Lift the top cover.
10. Place the tape reel, with the leader free and on the right side, onto the supply hub.
11. (Note the finger hole for the Hub Release Lever to the right of the supply reel bed.) Pull the Hub Release Lever toward you and rotate the supply hub clockwise at the same time. This causes the tape reel clamps in the hub to raise, locking the reel onto the hub.
12. Thread the tape leader through the tape path. Follow the diagram at the end of these instructions or the diagram on the metal plate to the right of the tape path.

Hold the tape onto the takeup reel hub with a finger and wrap the leader around the hub three or four times. Take any slack out of the tape.

13. Close the top cover. A LOAD sequence begins automatically.
14. (If the drive is mounted on rails in a cabinet)—slide the drive back into the cabinet.

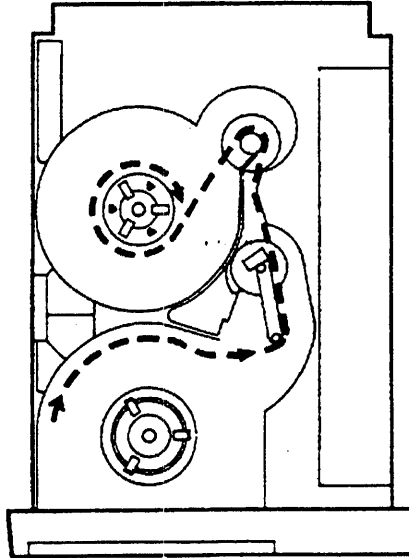

Tape Threading

**Control Panel Lights
Do Not Come On**

If your power outlets are functioning and the lights are still not operating, follow these steps:

1. Check that all power connections are secure.
2. Check that the **Main AC Power Switch** on the rear of the drive assembly is in the "1" (ON) position and the **Standby Switch** on the lower left of the front panel is in (ON).
3. If both the **Main AC Power Switch** and the **Standby Switch** were in their ON positions, try recycling power by switching them both OFF and then both ON again.
4. Check/replace the fuses.
 - a) Toggle the front panel **Standby Switch** to the out (OFF) position.
 - b) Access the rear of the drive and press the "0" side on the **Main AC Power Switch** to remove power from the drive.
 - c) Disconnect the power cable.

-
- d) Slide the fuse module out. The fuse module is located directly under the power cable receptacle. When the power cable is removed, a small slot on the top edge of the module can be accessed. Insert your fingernail or a small screwdriver into this slot to break the module free from its flush-mounted position.

Slide the module all the way out and inspect the fuse. Check for correct rating. The fuse in use is on the lower side of the module; the side where the module and receptacle arrows face each other.

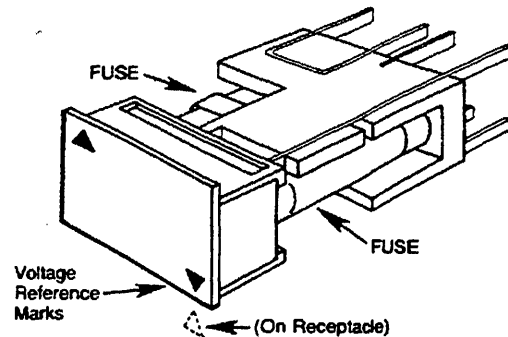

- e) Replace the fuse if necessary.

WARNING



Replace a blown fuse with one of the same type and rating. The fuse for 120V operation is 6 Amperes, the fuse for 240V operation is 3 Amperes (3.15 Amperes in Europe).

-
- f) Slide the fuse module back in, *making sure that the arrow on the edge of the fuse module case points to the correct voltage number on the fuse module (120V or 240V).*
- g) Reconnect the power cable.
- h) Apply power by pressing the "1" on the **Main AC Power Switch** in.
- i) Press the **Standby Switch** on front panel in (ON).

If the Control Panel lights still do not function properly, call your nearest authorized Hewlett-Packard distributor.

**Density and Unload/
Rewind Keys Do Not
Operate Correctly**

If the operation of the DENSITY Key and the UNLOAD/REWIND Key seems improper, check the value set into the Language Configuration (48). The value must be at least 32 to allow the drive to properly identify the functions of the DENSITY and UNLOAD/REWIND Keys. To check the value in Configuration 48:

1. Take the drive offline (press the **ONLINE** Key, if necessary).

2. Press **Option** to enter the Option Mode. *TEST ** appears in the display.

3. Press **NEXT** until *INFO ** appears.

4. Press **ENTER**. *INFO 0* appears in the display.

5. Use **NEXT** or **PREV** to bring *INFO 48* into the display.**

Pressing **NEXT increments the number by 1, pressing **PREV** decrements the number by 1. Pressing the lower right key on the panel, the **DENSITY** Key, increments the number by 10s, pressing the lower left key on the panel, the **ONLINE** Key, decrements the number by 10s.

6. Press **ENTER**.

The current value of the Language Configuration (48) now shows in the display. This number must be *at least 32*.

If the number is not *at least 32*, refer to the description of Configuration 48 and then use the procedure in "Setting a Configuration Option" (also in the Appendix) to change the setting in Configuration 48 to the value you want.

If the value is 32 or more, recycle power on the tape drive and do Steps 1 to 6 again. If the value is confirmed to be 32 or more contact your authorized Hewlett-Packard distributor.

7. When through reading the Language value, press **ENTER**. The display returns to *INFO **.

8. Press **OPTION** or **RESET** to leave the Option mode.

Power Failure Recovery Incomplete

When power is restored after a power failure, the drive automatically runs its poweron selftests and re-tensions the tape.

The most probable reason the drive may not recover from a loss of power is that the tape has spooled completely off the supply reel onto the takeup reel. When power is re-applied, the drive runs selftests and then searches forward about 25 feet looking for the BOT Marker. If power was lost when the tape was beyond EOT, the drive will pull the tape completely off the supply reel in its search for the BOT Marker.

If the automatic reLOAD fails after a power failure—and the selftest has passed (does *NOT* display *FAIL 0*), follow these steps:

1. (If the drive is mounted on rails in a cabinet)—pull the release handle on the bottom middle of the front panel to release the drive, then slide the drive out on its rails until the rail lock buttons snap into position.

2. Lift the top cover. Check to see if the tape has spooled completely off the supply reel onto the takeup reel. If it has, go to Step 3. If not, go to Step 5.

-
3. Manually thread the tape back through the tape path and wind it around the hub of the supply reel approximately 25 times, or until the EOT Marker passes through the tape path. (It helps to lightly moisten the last inch of the tape to help it initially cling to the supply reel hub.)

To ensure that the drive sees the EOT Marker, wind the Marker all the way back to the supply reel. This gives the drive room to re-tension and ramp up before the EOT Marker passes the BOT/EOT Sensor, located at the base of the Tension Arm.

4. Close the top cover. A LOAD sequence begins automatically.
5. If the tape door opened during the failure, close the tape door to re-initiate the LOAD sequence and then go to Step 8. If the tape door remained closed, go to the next step.
6. Lift the top cover.
7. Wind the takeup reel clockwise until the slack in the tape is removed.
8. Close the top cover. A LOAD sequence begins automatically.
9. (If the drive is mounted on rails in a cabinet)—slide the drive back into the cabinet.
10. Press **ONLINE** to resume ONLINE operations (if desired).

MANUAL TAPE UNLOADING

If you cannot wait for power to be restored before removing a tape from the drive, use the following steps:

1. (If the drive is mounted on rails in a cabinet)—pull the release handle on the bottom middle of the front panel to release the drive, then slide the drive out on its rails until the rail lock buttons snap into position.
2. Lift the top cover.
3. Rotate the supply reel counterclockwise to rewind the tape.
4. (Note the finger hole for the Hub Release Lever to the right of the supply reel.) Pull the Hub Release Lever toward you and rotate the supply hub counterclockwise at the same time. This causes the tape reel clamps in the hub to lower, unlocking the reel from the hub.
5. Remove the tape reel.
6. Close the top cover.
7. (If the drive is mounted on rails in a cabinet)—slide the drive back into the cabinet.

BOT/EOT Markers Must Be Replaced

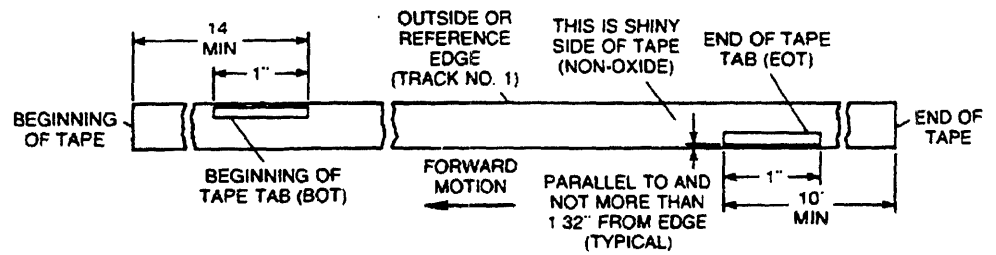

BOT/EOT Marker Locations

If a BOT Marker comes off, or the section on which it is mounted is cut off, replace the Marker using the diagram above for a guide. Place the BOT Marker a maximum of 16 feet from the physical beginning of the tape. Do not place the BOT Marker less than 14 feet from the beginning of the tape.

Tape and Tape Path Not Clean

Guidelines for maintaining your tape and tape path are in Chapter 4.

4

Tape Management

Overview

This chapter is divided into three sections: "Tape and Tape Path Problems", "Tape Path Care" and "Tape Library Care." Understanding and preventing the symptoms and problems presented here will significantly enhance the performance of your tape drive.

Taking preventative measures is in your best interest, since a clean tape path and clean tapes reduce read/write errors, shorten read/write times, lengthen tape life, and translate into less work for you.

Tape and Tape Path Problems

There are several sources of tape and tape path problems: contamination, tapes that leave oxide and binder on the tape path, high temperatures and humidity, and improper operating practices. To help you identify problems, here's a list of the most common symptoms:

Clear Filming and Brown Staining

A tape sheds binder and oxide during normal tape operations. Usually, debris from the tape can be removed by periodic cleaning. However, some combinations of humidity, temperature, tape tension, tape speed, and chemical composition of the binder in certain brands of tape may cause a deposit to be formed on the head that can not be removed by normal cleaning procedures. An additional problem is that these deposits can not even be seen. If allowed to accumulate, the head will have to be replaced.

If cleaning the head does not correct a high read error rate, contact your authorized Hewlett-Packard distributor. "Clear filming" and "brown staining" can be verified by a drop in read signal levels across all tracks. If this is the problem, further actions can then be worked out with regard to your particular site environment, procedures, and requirements.

Cinching

When you suddenly stop a spinning reel, the outer layers of tape continue to spin. This will cause loose windings within the tape pack to bunch.

Edge Damage

Pressing the reel flanges together may damage the edge of the tape. Edge damage may also occur if the tape is caught by the reel flange or tape path guide edges.

Pack slip

Slip appears as "steps" in an otherwise smooth winding. If you forget to place a vinyl strip or foam pad on a tape, sections of the tape may shift if you handle the tape roughly or subject it to impact, vibration, or thermal stress. Pack slip also causes uneven winding and rewinding.

Tape Stick and Blocking

High temperatures and humidity cause tape binder to soften and stick to the drive head or may cause tape layers to stick together. Either of these may remove the oxide coating.

Tape Path Care

For optimal performance, follow these suggestions for cleaning schedules, materials, and procedures.

Cleaning Schedule

How often you clean the tape path depends on usage, operating environment, and tape quality.

Most users find that they need to clean the tape path once every eight hours. However, if the error message *CHECK* begins to occur regularly, you should clean the tape path more frequently. If frequent cleaning does not improve reliability, check your tapes. Are the tapes old, worn, or kept in a dirty area? All old and worn tapes should be copied immediately and then discarded. You should evaluate tapes regularly.

The definitions in the following chart should help you develop an appropriate cleaning schedule.

MINIMUM	Clean the tape path thoroughly EVERY EIGHT HOURS if:
	<ul style="list-style-type: none">■ less than ten reels are used in eight hours■ you see no particles on the tape head after each reel of tape■ you do not suspect abnormal dust in the computer center from increased traffic or vacuuming.
NORMAL	Clean the tape path thoroughly EVERY ONE TO TWO HOURS of continuous running if:
	<ul style="list-style-type: none">■ more than ten reels are used in eight hours■ you see no particles on the tape head after each reel of tape■ you do not suspect abnormal dust in the computer center.
HEAVY	Clean the tape thoroughly AFTER EACH REEL of tape if:
	<ul style="list-style-type: none">■ particles appear on the tape head after each reel of tape■ you are reading interchange tapes from outside your computer center■ you are using new or little-used tapes (new tapes usually contain debris from the slitting process during their manufacture).
SPECIAL	Clean the tape path IF:
	<ul style="list-style-type: none">■ you suspect abnormal dust in the computer center because of custodial activity, equipment moves, supply delivery, or if the drive has not been used for several days.

Cleaning Schedule Guidelines

Read "Tape Library Care" in this chapter for general guidelines on tape use and storage and to determine whether environmental problems exist in your computer center.

Cleaning Supplies Use these materials to clean the tape path:

■ **CLEANING SOLVENT**

Hewlett-Packard supports only high-quality electronic-grade isopropyl alcohol of at least 90% concentration. The isopropyl mixture must consist of alcohol and distilled water only.

■ **NON-ABRASIVE, LINT-FREE CLOTHS AND/OR SWABS**

Please follow these precautions:

CAUTION



Do not use cleaner solutions which contain lubricants. Lubricants deposit on the tape head and impair performance.

Do not use alcohol cleaning solutions on the rubber gripping fingers on the takeup reel.

Do not use aerosol cleaners. The spray is difficult to control and may contain metallic particles that can damage the tape head.

Do not use soap and water on the tape path. Soap leaves a thick film, and water may damage electronic parts.

Discard the cloths and swabs after use. Even if they appear clean, they are contaminated.

Do not use facial tissues. Although they may seem effective, they leave highly abrasive lint in the tape path.

Cleaning Procedure

1. Pour a small amount of alcohol cleaner into a clean container, such as a small **UNWAXED** paper cup or, if the cleaner comes in a squeeze bottle, squeeze a small amount on a lint-free cloth or swab.
-

CAUTION



Alcohol dissolves wax. If you use a waxed cup, the wax transfers to the tape path.

DO NOT dip your cloths and swabs into the cleaner container or touch the cloths or swabs to the lip of the open container during pouring. This contaminates the solvent.

-
2. Applying gentle pressure in one direction, use a lint-free swab or cloth to clean the following surfaces (refer to the following figure for locations):
 - 1 – Read/Write/Erase Head
If swab appears dirty, repeat with new swab.
 - 2 – Tape Cleaner Block
If swab appears dirty, repeat with new swab.
 - 3 – Buffer Arm Movable Roller
 - 4 – Buffer Arm Fixed Guide
 - 5 – Speed Encoder
 - 6 – Use a lint-free wipe to brush out debris in the Supply Reel bed (depression) in the casting
 - 7 – Periodically check and wipe off the rubber gripping fingers on the Supply Reel hub. Use a dry or damp swab or cloth. **DO NOT USE ISOPROPYL ALCOHOL TO CLEAN THESE FINGERS.**

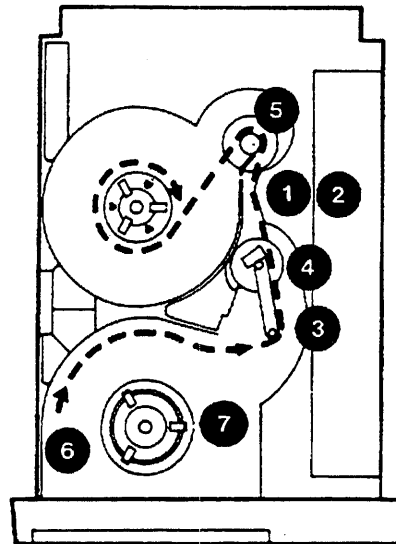

Cleaning Points

Tape Library Care

Using high quality tapes and following these guidelines prevents errors and lengthens the life of your tapes. Poor tape practices cause many failures.

NOTE The selection and use of media, supplies, and consumables are the customer's responsibility. Hewlett-Packard reserves the right to exclude from the warranty or service agreement any repairs for damage to HP products which HP reasonably determines or believes was caused by use of non-HP media or cleaning supplies. Hewlett-Packard will, upon request, repair such damage on a time and material basis.

-
- Storage**
- You may choose to use the Archival Tape Conditioning feature to improve tape stacking for storage. Refer to Appendix A, "Changing Rewind Speeds" in "Customizing Drive Operation" for the sequence of keystrokes.
 - Keep tapes in a clean environment at all times. Exposure to dust and other particles such as food and cigarette smoke impairs tape performance. Choose storage areas away from office activity to reduce contamination.
 - Maintain a constant temperature around 70°F (21°C) and a relative humidity around 40%. Tapes subjected to extremes in temperature or humidity may become sticky or brittle.
 - Do not stack tapes horizontally unless they are in metal canisters.
 - Secure the end of the tape by a vinyl strip or a foam pad to prevent tension loss. DO NOT use adhesive tape because it can leave a sticky residue.
 - During long-term storage, reduce contamination by sealing canisters in plastic bags. BE SURE TO REMOVE DUST ON THE OUTSIDE OF THE BAGS BEFORE REMOVING THE CANISTERS.

- Transportation**
- Avoid physical shock and extreme temperature changes.
 - Pack tapes in water-resistant containers when you are moving tapes from one location to another.
 - Secure the ends of the tape to maintain proper tension.
 - Avoid metal detection equipment (such as the kind in airports), because electromagnetic fields can be strong enough to cause data loss.

- Handling**
- Hold the tape reel by the hub or as close to the hub as possible.
 - Do not pick up the reel by the flanges; they are easily bent. If the flanges are bent, the tape may unwind unevenly, which can eventually cause edge damage.
 - Do not shake the tape. Shaking causes pack slip.
 - Prevent sharp blows to the reels. The reel could fracture and damage the tape.

- Winding**
- Proper tension is necessary to ensure smooth movement of the tape and accurate data transfer. Excessive tension permanently distorts the backing, while loose tension causes cinching. A properly maintained tape drive will wind tapes at the correct tension.
- To prevent the pack from losing its tension, secure the end of the tape with either a vinyl strip or a foam pad when you remove it from the drive.
 - Tapes can be contaminated if they are wound onto dirty reels. Clean empty reels before using them.

- Adopt a program of regular inspection, winding, and rewinding of stored tapes every six to nine months to ensure wind quality.

Evaluation You can stop your system from wasting valuable time retrying and skipping bad sections of tape by evaluating your tapes regularly. Reels of tape should be discarded once they reach one or more of the following levels:

- 150 single-track errors every 2400 feet
- 10 total (in any combination) two- and three-track errors every 2400 feet
- 1 permanent write error every 2400 feet.

These are maximum error rates. Please evaluate your tapes using whatever system or program is available to you, but set your levels low to prevent data loss and retries.

Labeling To run a well-managed tape library, you must keep accurate records of each tape's condition and adopt a regular schedule of evaluation. This will help you ensure reliability, lengthen tape life, and spot problems quickly.

Use reliability labels, similar to the one in the following figure, to reduce paperwork and increase your efficiency. The labels eliminate files, since they allow you to record a tape's history on the reel itself. You need only glance at the label to identify the condition of the tape and determine when maintenance is required.

The diagram shows a curved rectangular label divided into several sections. On the left side, there are two rows for 'SERIAL No.' and 'FILE No.', followed by a larger section for 'NOTES:'. At the bottom left, it specifies 'DENSITY = 800 1600 6250'. On the right side, there are two rows for 'CREATED' and 'PURGED', each with a line for 'DATE' and 'OPERATOR'. At the bottom right, there is a section for 'RETENTION PERIOD'.

Example of a Tape Reliability Label

Special care must be taken with tapes written in 6250XC format (Option 400). This format is intended for large backups and is not generally used for interchange unless the interchange party has an 88780B with Extra Capacity storage capability (Option 400 installed). One other tape drive that may be used by the interchange party is an HP 7980XC. We recommend that you mark tape labels with "6250XC" if the Extra Capacity feature is used.

This labeling can be done manually on the tape label or placed in the "Comments" field of an automated tape library manager.

Labeling tapes is especially important in an installation that uses several different types of tape drives. Although the 88780B with Option 400 recognizes and is able to correctly expand the data automatically, other tape drives only recognize that the tape is a 6250 cpi tape; a host error will be returned when reading is begun.

Operators should be trained to mount 6250XC tapes only on Extra-Capacity-capable tape drives when data is to be read back. (Of course, ANY tape may be mounted on ANY tape drive for a write.)

SERIAL No. _____	DATE _____	OPERATOR _____
FILE No. _____	CREATED _____	PURGED _____
NOTES:		
DENSITY = 800 1600 6250 6250 XC		RETENTION PERIOD

Suggested Extra Capacity Reel Label

Resources If tape and tape path problems persist after following all the suggested procedures and practices in this chapter, call your nearest Hewlett-Packard distributor. The tape drive may need to be repaired by a service engineer.

The following publications are available for those who wish to learn more about tape care and library management:

- *Care and Handling of Computer Magnetic Storage Media*, Sidney Geller, National Bureau of Standards Special Publication #500-101, 1983.

Contact:

Superintendent of Documents
U.S. Government Printing Office
Washington, D.C. 20402

-
- *The Handling and Storage of Computer Tape*, 3M Company.

Contact:

Technical Service
Data Recording Products Division
3M Company
3M Center
St. Paul, Minnesota 55101

- *Success With Magnetic Tape*, Hewlett-Packard Company, HP P/N 5953-7131, 1986.

Contact:

Hewlett-Packard Direct Marketing Division
1320 Kifer Road
Sunnyvale, CA 94084
(800) 538-8787 in U.S.
(406) 738-4133 in Alaska, California, or Hawaii

Appendix A Set Up and Configuration

Site Selection

The 88780B tape drive is designed to function within a wide range of temperature and humidity conditions. You should, however, maintain a clean, climate-controlled operating area to maximize the drive's performance.

Actual operating range is limited by the magnetic tape. Because the tape path and the tape are susceptible to contamination and are sensitive to changes in temperature and humidity, tape handling procedures should include the suggestions outlined in Chapter 4.

For optimal performance, follow these guidelines when selecting a site:

- the area does not have to be air conditioned, but the temperature should fall between 65°F and 75°F, non-condensing (18°C to 24°C)
- position the drive away from frequently-used doors and walkways, stacks of supplies that collect dust, and smoke-filled rooms
- leave a minimum of 3 inches (70 to 80 mm) behind the rear of the drive to allow air to circulate.

NOTE



Follow the most stringent environmental specifications for any device within your system. Adhere to any restrictions listed for that device to maximize system performance.

WARNING



Do not operate the drive until a your authorized Hewlett-Packard distributor has installed it and thoroughly checked its operation. If the system is configured incorrectly or there are signs of damage, you could injure yourself or the drive when the drive is powered up. Repairs necessitated by the misuse or improper operation of the drive are not covered under warranty.

Setting the ADDRESS/ID Number

Your authorized Hewlett-Packard distributor will set the Address or ID number during installation. Use the following instructions should you ever need to change it.

1. Take the drive offline.
2. Press **OPTION** to enter the Option Mode. *TEST ** appears in the display.
3. Press **NEXT** until *ADDR ** or *ID ** appears in the display. *ADDR ** appears if you have a Pertec-compatible interface, *ID ** appears if you have a SCSI interface.
4. Press **ENTER**.
5. Using **NEXT** or **PREV**, bring the ADDRESS/ID number desired into the display.
6. Press **ENTER**.

The ADDRESS/ID you selected appears as *SET <#>*. The “#” is the address number (Pertec-compatible) or the ID number (SCSI). This display lasts for one second and then returns to the *ADDR ** or *ID ** display (depending on interface installed).

7. Leave the Option Mode by pressing **OPTION** or **RESET**.

Configurations

The following tables show the configurations set into the non-volatile memory of the drive when the SCSI or Pertec-compatible interface is installed.

You may, at any time, change the setting for any configuration that is designated “Unlocked.”

If you want to change any configuration that is designated “Locked”, you will have to contact your Hewlett-Packard distributor. Most of the “Locked” configurations determine basic parameters of the tape drive and, in almost every case, are not something you would want to change.

You will find the procedure for changing an “Unlocked” configuration after the table of configurations, under “Setting a Configuration Option.”

You should keep a tape record of the configurations you are using in the drive. This enables you to restore your configurations after any service that requires power to be removed from the non-volatile memory. Saving configurations to tape should be done by the distributor at the time of installation, but you may also do it yourself at any time.

Configurations are saved to tape by running Test 128. Configurations are reloaded into the non-volatile memory by running Test 129. Use the procedures outlined in Chapter 3, “Running Tests.”

Drives with SCSI Interface (Kits HP 88754A or HP 88755A)
– Initial Configurations –

Configuration Name	Default Setting	Config. Number	Lock/Unlock
Enable Non-Volatile change	OFF	40	Unlock
Auto Online	ON	41	Unlock
Media Removal	ON	42	Lock
Operator Timeout	10	43	Lock
Archival Rewind	REW *	44	Unlock
Operator Select Archive	OFF	45	Unlock
Manual Density	6250	46	Unlock
Operator Select Density	OPEN	47	Lock
Language	48	48	Unlock
Recovered Error Report	1	49	Lock
Immediate Response	ON	50	Lock
Tape Marks to disable			
Immediate Reporting	OFF	51	Lock
Write Retry Count	17	52	Lock
Low Density Gap Size	6	53	Lock
High Density Gap Size	4	54	Lock
Stop at EOT	0	55	Lock
Write Holdoff Time (seconds)	20	56	Lock
Write Startup Point	OFF	57	Lock
Retry Before Skip	1	58	Lock
Write Auto-Hitch	1	59	Lock
Readaheads	ON	60	Lock
Tape Marks to terminate			
readaheads	OFF	61	Lock
Read Retry Count	9	62	Lock
Trailing Buffer	0	63	Lock
Read Startup Point (eighths)	2	64	Lock
Max. Physical Record Size	15	65	Lock
Max. Files per Physical Record	OFF	66	Lock
Max. Bytes per Physical Record	OFF	67	Lock
Max. Accumulated Tape Marks	0	68	Lock
Max. Accumulated Bytes	99	69	Lock
Expansion Protection	ON	70	Lock
Performance Option	OFF	71	Lock
Record Optimization Threshold	OFF	72	Lock
Data Comp. Optimization Sample			
Period	2	73	Lock
Data Comp. Optimization Threshold	32	74	Lock
Gauge Usage	0	75	Lock

Configuration Name	Default Setting	Config. Number	Lock/Unlock
No Break on Failure	OFF	76	Lock
Activity Indicator	OFF	77	Unlock
Lock Interface Density Select	OFF	78	Lock
Lock Interface Address	OFF	79	Lock
Interface Non-Volatile RAM change	OFF	80	Lock
Block Length	0	81	Lock
Bus Inactivity Limit	1	82	Lock
Disconnect Time Limit	0	83	Lock
Disconnect Length	0	84	Lock
Inquiry Field	0	85	Lock
Reset Method	ON	86	Lock
Read EOM Reported	OFF	87	Lock
SCSI II Compatible	1	88	Lock
Report EOT at Early EOT	OFF	89	Lock
Check Incoming Parity	ON	90	Lock
Vendor-Unique Density	ON	91	Lock
Suppress Illegal Length	OFF	92	Lock
Reserved	—	92-96	Lock

**Drives with Pertec-compatible Interface (88752A Kit)
- Initial Configurations -**

Configuration Name	Default Setting	Config. Number	Lock/Unlock
Enable Non-Volatile change	OFF	40	Unlock
Auto Online	ON	41	Unlock
Media Removal	ON	42	Lock
Operator Timeout	10	43	Lock
Archival Rewind	REW*	44	Unlock
Operator Select Archive	OFF	45	Unlock
Manual Density	6250	46	Unlock
Operator Select Density	OPEN	47	Lock
Language	48	48	Unlock
Recovered Error Report	OFF	49	Lock
Immediate Response	ON	50	Lock
Tape Marks to disable Immediate Reporting	2	51	Lock
Write Retry Count	17	52	Lock
Low Density Gap Size	6	53	Lock
High Density Gap Size	4	54	Lock
Stop at EOT	0	55	Lock
Write Holdoff Time (seconds)	5	56	Lock
Write Startup Point	OFF	57	Lock
Retry Before Skip	0	58	Lock
Write Auto-Hitch	1	59	Lock
Readaheads	ON	60	Lock
Tape Marks to terminate readaheads	OFF	61	Lock

Configuration Name	Default Setting	Config. Number	Lock/Unlock
Read Retry Count	9	62	Lock
Trailing Buffer	0	63	Lock
Read Startup Point (eighths)	2	64	Lock
Max. Physical Record Size	15	65	Lock
Max. Files per Physical Record	OFF	66	Lock
Max. Bytes per Physical Record	OFF	67	Lock
Max. Accumulated Tape Marks	0	68	Lock
Max. Accumulated Bytes	99	69	Lock
Expansion Protection	ON	70	Lock
Performance Option	OFF	71	Lock
Record Optimization Threshold	OFF	72	Lock
Data Comp. Optimization Sample Period	2	73	Lock
Data Comp. Optimization Threshold	32	74	Lock
Gauge Usage	0	75	Lock
No Break on Failure	OFF	76	Lock
Activity Indicator	OFF	77	Unlock
Lock Interface Density Select	OFF	78	Lock
Lock Interface Address	OFF	79	Lock
Interface Non-Volatile RAM change	OFF	80	Lock
PERTEC flavors 1 = Cipher 990, 2 = CDC	1	81	Lock
1 = read rev w/data, 2 = space rev	2	82	Lock
1 = fast read, 2 = ramped read	1	83	Lock
1 = offline on hard error, 2 = online	1	84	Lock
Report BOT Write	OFF	85	Lock
Write Transfer Rate	9	86	Lock
Read Transfer Rate	9	87	Lock
Write Delay	0	88	Lock
Read Delay	2	89	Lock
Density on NRZI	0	90	Lock
Report EOT at Early EOT	OFF	91	Lock
IDEN Selects Density	OFF	92	Lock
Special Options	0	93	Lock
Reserved	—	94-95	Lock
Hardware Check Address	OFF	96	Lock

NOTE

The following descriptions show what settings are available if you want to change an "Unlocked" configuration from its default setting.

Most of the "Locked" configurations change basic drive parameters and are not included in this Guide. If your application requires changing a "Locked" configuration from its default value, contact your authorized Hewlett-Packard distributor.

(CONF 40) – ENABLE CHANGE TO THE NON-VOLATILE MEMORY
Choices: ON or OFF.

Allows changes to the non-volatile configuration options to be made from the Control Panel. This configuration must be set to "ON" if you want to store changes in non-volatile RAM. If this configuration is not set to "ON", any changes to configurations made from the Control Panel will be lost if power is cycled to the drive.

If this configuration is set to "ON" to save configuration changes, it should be reset to "OFF" when you are through changing configurations.

(CONF 41) – AUTO ONLINE
Choices: ON or OFF.

Causes the drive to automatically place itself ONLINE when the tape LOAD sequence completes.

(CONF 44) – ARCHIVAL TAPE CONDITIONING REWIND
Choices: REW * or ATC *.

When ON, the drive performs all rewinds at the slower Archive Tape Conditioning speed of approximately 50 ips.

(CONF 45) – OPERATOR SELECT ARCHIVE
Choices: ON or OFF.

When set to ATC *, the drive prompts the operator to select either the Archive Tape Conditioning speed or the normal speed for rewind. The drive prompts the operator before each loading operation.

(CONF 46) – MANUAL DENSITY
Choices: 800 (Option 800 installed), 1600, and 6250.

Sets the default density of the tape drive. This density will be used for writes when the tape is positioned logically at BOT. The default density may also be more easily set by using the DENSITY Key on the front panel (see Step 9, "Set the write density", in "LOADING TAPE", Chapter 2).

(CONF 48) – LANGUAGE
Choices: see description below

NOTE: Default configurations may differ, depending on your agreement with your distributor.

The default language configuration is formed by adding *at least* 32 to the base value for your chosen language (0,1,2,or 3 as shown in the table below). The value 32 enables the proper identification of Control Panel keys. **IF THE VALUE IN CONFIGURATION 48 IS NOT AT LEAST 32, THE DENSITY AND UNLOAD/REWIND KEYS WILL NOT OPERATE PROPERLY.**

- 0 – English + 32 (Control Panel) + <other>
- 1 – German + 32 (Control Panel) + <other>
- 2 – French + 32 (Control Panel) + <other>
- 3 – Spanish + 32 (Control Panel) + <other>

The default value for English in your drive may, therefore, be 32 (0 + 32). The default value for German may be 33 (1 + 32), for French may be 34 (2 + 32), and for Spanish may be 35 (3 + 32).

Depending on the agreement you have made with your distributor, your default setting may also include the addition of “other” language configurations as follows:

- adding 4 replaces the READY message with NO TAPE
- adding 8 replaces the READY message with UNIT #
- adding 16 replaces the READING message with RETRY during retries.

Hewlett-Packard ships the 88780B with a default setting of 48. This means

English language	= 0
Control Panel	= 32
RETRY Message	= 16
	<hr/>
Total	48

(CONF 77) – ACTIVITY INDICATOR
Choices: OFF, 1,2,3

Displays an indicator in the right-most digit of the front panel when host commands are being processed.

- 1 – indicator = -
- 2 – indicator = --
- 3 – indicator = *

Setting a Configuration Option

1. Take the drive offline.
2. Press **OPTION** to enter the Option Mode. *TEST ** appears in the display.
3. Press **NEXT** until *CONF ** appears.
4. Press **ENTER** to select the configuration set mode.

-
5. Using **NEXT** or **PREV**, brings *40* into the display. This configuration must be set before any others; it is the *Enable Change to the Non-Volatile Memory*.
 6. Press **ENTER**.
 7. Press **NEXT** or **PREV** to display **ON**.
 8. Press **ENTER**.
 9. Using **NEXT** or **PREV**, bring the number of the desired configuration into the display.

Pressing **NEXT increments the number by 1, pressing **PREV** decrements the number by 1. Pressing the lower right key on the panel, the **DENSITY** Key, increments the number by 10s, pressing the lower left key on the panel, the **ONLINE** Key, decrements the numbers by 10s.
 10. Press **ENTER**.
 11. A "VALUE" of the configuration will appear in the display. Use **NEXT** or **PREV** to display the "VALUE" desired (used when selecting a **LANGUAGE**; i.e. 0 [English], 1 [German], 2 [French], or 3 [Spanish]).
 12. Press **ENTER** to select the "VALUE". The display will show *SET <value>*.
 13. Press **RESET** to return to the "ready" offline state.

Customizing Drive Operation

Changing Rewind Speeds

Two rewind speeds may be selected; high-speed (standard) or Archival Tape Conditioning speed.

When Archival Tape Conditioning is selected, rewind speed is slowed to approximately 50 inches per second so that air pockets, which can cause uneven tape stacking, are eliminated. For additional tape storage guidelines see "Tape Library Care" in Chapter 4.

Three methods of using the two rewind speeds are available:

- Regular, high-speed rewind always
- Archival tape conditioning rewind always
- Regular/Archival Tape Conditioning choice always—
Prior to loading tape, the drive flashes the current rewind speed (REW or ATC). Press **NEXT** or **PREV** until desired speed is displayed, then press **ENTER**. If no selection is made in 10 seconds, the drive defaults to the current speed selection in Configuration 44.

To set any of the three rewind configurations, do the following nine steps and then continue under the heading of what you want to do; SELECT HIGH-SPEED (REGULAR) REWIND ALWAYS, SELECT ARCHIVAL TAPE CONDITIONING REWIND ALWAYS, or SELECT REWIND CHOICE MODE.

1. Take the drive offline. (Press **ONLINE**, if necessary.)
2. Press **OPTION** to enter the Option Mode. *TEST ** appears in the display.
3. Press **NEXT** to bring *CONF ** into the display.
4. Press **ENTER** to select the configuration set mode.
5. Bring the number *40* into the display.**

Pressing **NEXT increments the number by 1, pressing **PREV** decrements the number by 1. Pressing the lower right key on the panel, the **DENSITY** Key, increments the number by 10s, pressing the lower left key on the panel, the **ONLINE** Key, decrements the number by 10s.

Configuration 40 must be set before any others; it is the *Enable Change to the Non-Volatile Memory*.

6. Press **ENTER**. The display shows the current setting for Configuration 40. This configuration should normally be **OFF**.
7. Use **NEXT** or **PREV** to bring **ON** into the display.
8. Press **ENTER**. Values currently in non-volatile memory may now be changed.

The display will show *SET 40* for about 1 second to confirm that it has placed the value for **ON** in Configuration 40. Then, *CONF ** re-appears in the display.

9. Press **ENTER** to select the configuration set mode again.

TO SELECT HIGH-SPEED (REGULAR) REWIND ALWAYS:

10. Bring *44* into the display. (Press the **NEXT** Key four times.)

Configuration 44 is Archival Tape Conditioning Rewind.

11. Press **ENTER** to select the configuration.
12. The display will show your current setting for Configuration 44. Use **NEXT** or **PREV** to choose the type of rewinds you want.

When you press either **NEXT** or **PREV**, the choices alternate between the following:

*REW ** – Normal (high-speed) rewind

*ATC ** – Archival Tape Conditioning (slow-speed) rewind.

13. When *REW ** shows in the display, press **ENTER**.

The display will show *SET 44* for about 1 second to confirm that it has placed the selection in Configuration 44. Then, *CONF ** re-appears in the display.

14. Press **OPTION** or **RESET** to leave the **OPTION** mode and return to *READY*.

TO SELECT ARCHIVAL TAPE CONDITIONING REWIND ALWAYS:

10. Bring *44* into the display. Use keys as in Step 5.

Configuration 44 is Archival Tape Conditioning Rewind.

11. Press **ENTER** to select the configuration.
12. The display will show your current setting for Configuration 44. Use **NEXT** or **PREV** to choose the type of rewinds you want.

When you press either **NEXT** or **PREV**, the choices alternate between the following:

*REW ** – Normal (high-speed) rewind

*ATC ** – Archival Tape Conditioning (slow-speed) rewind.

13. When *ATC ** shows in the display, press **ENTER**.

The display will show *SET 44* for about 1 second to confirm that it has placed the selection in Configuration 44. Then, *CONF ** re-appears in the display.

14. Press **OPTION** or **RESET** to leave the **OPTION** mode and return to *READY*.

TO SELECT REWIND "CHOICE MODE":

10. Bring 45 into the display. Use keys as in Step 5.

Configuration 45 is Operator Select Archive..

11. Press **ENTER** to select the configuration.

12. The display will show your current setting for Configuration 45. Use **NEXT** or **PREV** to display your choices.

When you press either **NEXT** or **PREV**, the choices alternate between the following:

ON – The operator will be given the opportunity to choose between normal and Archival Tape Conditioning rewinds after each tape is **LOAD**ed.

OFF – No choice will be presented to the operator. Rewind speed will be determined by the setting of Configuration 44, Operator Tape Conditioning Rewind (see previous procedure).

13. When *ON* shows in the display, press **ENTER**.

The display will show *SET 45* for about 1 second to confirm that it has placed the selection in Configuration 45. Then, *CONF ** re-appears in the display.

14. Press **OPTION** or **RESET** to leave the **OPTION** mode and return to *READY*.

Monitoring the Extra Capacity Data Storage Rate (Option 400)

1. Take the drive **OFFLINE** (press the **ONLINE** Key, if necessary).

2. Press **OPTION**.

3. Press **NEXT** until *INFO ** appears in the display.

4. Press **ENTER**. The display will show *INFO 0*.

5. Bring *INFO 30* into the display.**

Pressing **NEXT increments the number by 1, pressing **PREV** decrements the number by 1. Pressing the lower right key on the panel, the **DENSITY** Key, increments the number by 10s, pressing the lower left key on the panel, the **ONLINE** Key, decrements the number by 10s.

6. Press **ENTER**.

The tape write compression rate for the **LAST** compressed (Extra Capacity format) tape written is displayed. The number displayed shows the amount of tape that would have been required for a normal **GCR** format tape **COMPARED** to the amount of tape actually used to write the Extra Capacity tape. For example, a value of 240 means 240% or a 2.4-to-1 tape compression ratio.

Changing the Voltage Configuration

7. When through reading the compression rate, press **ENTER**. The display returns to *INFO **
8. Press **OPTION** or **RESET** to leave the Option mode.

REMOVE POWER FROM THE DRIVE UNIT

1. Toggle the front panel **Standby Switch** to the out (OFF) position.
2. Press the "0" side on the **Main AC Power Switch** on the rear panel to remove power from the drive.
3. Disconnect the power cable.

CHANGE THE VOLTAGE CONFIGURATION

4. Slide the fuse module out.

The fuse module is located directly under the power cable receptacle on the rear of the drive unit. When the power cable is removed, a small slot on the top of the module can be accessed. Insert your fingernail or a small screwdriver into this slot to help slide the module out from its flush-mounted position. Pull the fuse module all the way out.

WARNING



The correct fuse for the selected voltage must be in the proper receptacle in the holder.

For 110-120V operation, the fuse is 6 Amperes. For 220-240 V operation, the fuse is 3 Amperes (3.15 Amperes in Europe). Viewed from the end of the fuse holder as the holder is being inserted, the "active" fuse will be on the right side of the holder—the same side as the Voltage Reference Mark.

5. Rotate the fuse module so that the desired voltage rating arrow ("110-120 V" or "220-240 V") aligns with the arrow on the lower edge of the receptacle. Ensure that the correct fuse is in on the right side (see WARNING).

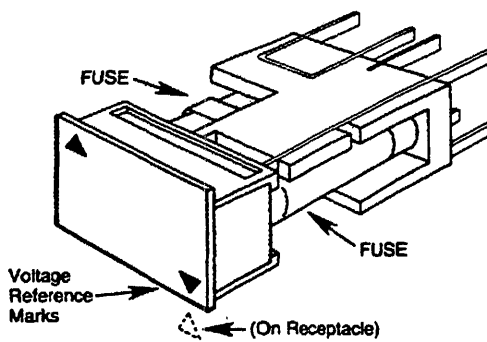

Fuse Module

-
6. Connect the appropriate power cable to the power receptacle (110-120 V or 220-240 V cable).
 7. Apply power by pressing the “1” on the **Main AC Power Switch**.
 8. Press the **Standby Switch** on the front panel in (ON).

Appendix B Technical Specifications

Drive Specifications

Transfer Rate to Tape (max.)	
6250 GCR	769 Kbytes/s
1600 PE	208 Kbytes/s
800 NRZI	104 Kbytes/s

Transfer Rate to Tape (avg.)	
6250 GCR	747 Kbytes/s
	(64K blocks - 0.3-inch gap)
1600 PE	198 Kbytes/s
	(16K blocks - 0.5-inch gap)
800 NRZI	99 Kbytes/s
	(8K blocks - 0.5-inch gap)

Burst Transfer Rate to Buffer (max.)	
SCSI	1.5 Mbytes/s
Perfec-compatible	0.33-1.6 Mbytes/s

Speed (nominal)	
Read/Write	
GCR	123 ips
PE/NRZI	130 ips
Rewind	320 ips average, 450 ips maximum (90 seconds to rewind a 2400-ft tape)

Density/Format	
Density	6250 cpi GCR 6250 cpi Extra Capacity (Opt.400) 1600 cpi PE 800 cpi NRZI (Opt.800)
Formatted Data Capacity (2400-ft reel)	140 Mbytes (typ. 6250 cpi) 200-700 Mbytes (typ. 6250 cpi Extra Capacity—Opt.400) 40 Mbytes (typ. 1600 cpi) 20 Mbytes (typ. 800 cpi—Opt.800)

Maximum Physical Block Size On Tape*	
6250 GCR	256 Kbytes
1600 PE	64 Kbytes
800 NRZI	64 Kbytes
*block size may be limited by host operating system	

Reliability	
Hard Error Rate* (will not exceed)	
GCR Read	1 in 10 ¹¹ *
Write	1 in 10 ¹⁰

PE Read	1 in 10 ¹⁰ *
Write	1 in 10 ⁹
NRZI Read	1 in 10 ¹⁰ *
Write	1 in 10 ⁹

*at 90% statistical confidence

Reliability

Hard Error Rate* (will not exceed)	
GCR Read	1 in 10 ¹¹ *
Write	1 in 10 ¹⁰
PE Read	1 in 10 ¹⁰ *
Write	1 in 10 ⁹
NRZI Read	1 in 10 ¹⁰ *
Write	1 in 10 ⁹

*at 90% statistical confidence

FUNCTIONAL CHARACTERISTICS

Internal Buffer Size	512 Kbytes
Operating Mode	Streaming
Interface	SCSI, PERTEC-compatible

POWER REQUIREMENTS

Line Voltage (+/-10%)	100-120 VAC
	200-240 VAC
Line Frequency (+ 10% -4%)	50-60 Hz
Power Consumption	
Maximum	250 Watts
Standby	20 Watts
Idle	170 Watts

PHYSICAL SPECIFICATIONS

Mechanism	
Height	222 mm (8.75 in.)
Width	483 mm (19.0 in.)
Depth	681 mm (26.8 in.)
Weight	31 kg (68 lbs)
Shipping Weight	47 kg (93 lbs)

Tape Specifications

Width	12.7 mm (0.5 in.)
Thickness*	0.038 mm (1.5 mils)
	Tape should meet or exceed ANSI X3.40-1983)

*see "Using 1-Mil Tape" at the end of these specifications

Tension	283 g (10 oz ±2.5 oz)
Reel Sizes	267 mm (10.5 in.)
	216 mm (8.5 in.)
	178 mm (7.0 in.)
	152 mm (6.0 in.)

Environmental Specifications

Temperature	
Operating	15-32 C
Non-Operating	0-55 C
Storage	-40 to 70 C
Rate of Change	20 C per hour
Relative Humidity	
Operating	Tape medium limited to 20%-80% at 25 C maximum wetbulb temperature
Storage/Shipment	90% at 40 C
Altitude	
Operating	3000 m (10,000 ft)
Non-Operating	15,300 m (50,000 ft)
Shock	
Transportation	Trapezoidal pulse, 188 ips, 30 G
End-Use	Half-sine pulse, 57 ips, <3 ms duration approx. 150 G
Vibration	
Operating Random	5-500 Hz, 0.21 G RMS
Non-Operating Random	5-500 Hz, 2.0 G RMS
Non-Operating Swept Sine	5-500 Hz, 0.5 G (0-peak)
Audible Noise (weighted sound power)	
Read Write	
Operation	6.6 Bels (A)
Tape Loading	
Operation	7.2 Bels (A)
Heat Dissipation	1280 BTU/hr maximum, 850 BTU/hr typical
Safety	
Underwriters Laboratories	UL 478, 5th Edition (UL listed)
Canadian Standards Association	C22.2 No. 154-M1983 (CSA certified)
International Electrotechnical Commission	IEC 380, 435 (complies)
Technischer Uberwachungs-Verein Bayern Inc. (TUV certified)	DIN IEC 380/VDE 0806/08.81 IEC 435/VDE 0805/11.84
Emissions	
Federal Communications Commission	FCC-A
Fernmeldetechnisches Zentralamt (Telecommunications Central Office, West Germany)	FTZ 1046/84 (with level B Controller) VDE-B
Voluntary Control Council for Interference by Data Processing Equipment and Electronic Office Machines (VCCI)	Class 1 0dB

Using 1-Mil Tape

Hewlett-Packard supports the use of 1-mil (3600-ft reel) tapes on the HP 88780B tape drive only under certain conditions. These conditions are stated at the end of the following background information.

Electrically and magnetically, 1-mil tapes are equivalent to ANSI-standard 1.5-mil tapes, but do not meet ANSI thickness specifications due to their thinner Mylar substrate. Thin tape was designed for low-speed datalogging operations.

Two characteristics of 1-mil tape must be taken into account before this tape is used; 1-mil tapes are more susceptible to deformation and breaking, and thin tapes conform to the read/write heads differently and therefore wear the heads differently than 1.5-mil tapes.

With regard to tape deformation, the HP 88780B will physically handle 1-mil tapes without deforming or breaking them. All tape operations are supported, including autoload.

With regard to different head wear patterns, the HP 88780B heads are affected by use of 1-mil tape in the same way as heads on any other tape drive; the critical read/write area of the head wears at an increased rate and forms a different profile from that made by 1.5-mil tape.

When a 1.5-mil tape is mounted on a drive in which the read/write area of the head has been worn by frequent use of 1-mil tape, the thicker 1.5-mil tape cannot conform to the wear profile caused by the 1-mil tape and will pass over the read/write area of the head at a greater distance. This increased tape-to-head distance causes signal loss. The effect of signal loss can be an increase in read and write errors. This effect is true for all industry-standard half-inch tape drives.

Because of the incompatibility of the head wear profiles, Hewlett-Packard can support the use of 1-mil tapes on the HP 88780B drive only if the following guidelines are used:

- * if a significant portion (more than 1 tape in 10) of the tapes used on the drive are 1-mil tapes, we recommend that a drive be dedicated to the use of the thinner tapes
- * if less than 1 tape in 10 used on the drive is a 1-mil tape, AND at least 10 1.5-mil tapes are mounted between the mountings of the 1-mil tapes, the two tape types can be used on the same drive.

Glossary

- ADDRESS** A number that identifies the location to which the CPU (or "host") can send data or from which the CPU receives data.
- ARCHIVAL TAPE CONDITIONING** An optional method of rewinding a tape which is going into long-term storage. The tape is rewound back onto the original (supply) reel at a reduced speed which prevents air from being trapped between tape layers; resulting in a smooth, even tape stack on the reel.
- AUTOLOAD** Capability of a tape drive to perform a LOAD operation automatically (see LOAD).
- BACKUP** The process of copying data from one mass storage device to another.
- BLOCK** A group of data handled as a single unit.
- BOT** Reflective marker that indicates the beginning of the space available for data storage on the tape.
- BPI** Bits-Per-Inch (when considering one track). Is also known as Bytes-Per-Inch or Characters-Per-Inch (CPI) if one inch of the full width of the tape is considered. (Bits are recorded in parallel.)
- BUFFER** A block of memory that temporarily stores data being transferred from one device to another; the buffer compensates for the different processing rates of the devices. This drive has a 512 kbyte buffer. A high-speed buffer is also called a cache.
- BUS** A bundle of wires over which computer devices can communicate. The bus allows connection of multiple devices which can communicate with the host simultaneously.
- CACHE** A high-speed buffer used to store sequences of instructions from the main memory. When the CPU needs an instruction, it first searches cache memory instead of the slower main memory.
- CONFIDENCE TEST** A diagnostic or series of diagnostics that assures the operator or service personnel that the drive is functioning correctly. A confidence test, for example, may test all of the control panel indicators by lighting them in sequence.
- CPI** Characters-Per-Inch; a measurement of tape density. Density is expressed using this term when all tracks in one inch of tape are looked at in cross-section (eight data tracks plus one track containing parity). When only one track is considered, the term bpi is used. (See BPI.)
- CPU** Central Processing Unit; also called "host." The CPU is where instructions or programs are decoded and executed.
- CRIMPER** A small instrument that cuts and rounds the tip of the tape.
- DATA COMPRESSION** The process of maintaining the same information in fewer bits.
- DIAGNOSTICS** Tests that "diagnose" or detect hardware problems or errors.
- DENSITY** The number of characters or bits that can be recorded in a given length of tape; expressed in characters-per-inch (cpi) or bits-per-inch (bpi).
- DIRECTORY** The table of contents for the files stored on a tape or disc.

EOT	Reflective marker that indicates the end of the space allowed for data recording. This marker is usually placed about 10 feet from the physical end of the tape.
ERROR LOG	A block of memory in the drive that logs recent errors.
EXTRA CAPACITY	The term used when referring to data compression on a HP 88780B EXTRA CAPACITY tape drive. Standard-length tapes are able to store more information when written to in "Extra Capacity" format and can, therefore, be viewed as having an "extra capacity" for information. Extra Capacity is also known as "6250XC."
GCR	Group-Coded Recording format. Enables a drive to store 6250 characters per inch and includes the ability to detect and correct simultaneous errors in up to two tracks.
HEAD	The assembly that writes electromagnetic bits onto tape and/or reads previously written bits from tape.
IMAGE BACKUP	(Usually applied to backing up of a random-access device; i.e. disc). All sectors and cylinders of a disc are copied, serially, to the backup device without any attempt to assemble complete files. Fragmented files remain fragmented files.
IPS	Inches Per Second; a measurement of tape speed.
KBYTE	A unit of measurement for memory storage, also called "k" or "kilobyte." One kilobyte is equal to 1,024 bytes.
LOAD	To move tape from the supply reel, through the tape path to the takeup reel, establish tension, and position the Beginning of Tape point (BOT) at the "start" point with respect to the head.
MBYTE	A unit of measurement for memory storage, also called "Mb" or "megabyte." One megabyte is equal to 1,024,000 bytes (approximately one million).
MTBF	Mean Time Between Failures; the Mean of the number of power-on hours between hardware failures that necessitate repair.
NRZI	Nonreturn-To-Zero Inverted format. Enables a drive to store 800 characters per inch and includes the ability to detect (but not correct) errors.
OFFLINE	Tape drive mode in which the drive will not execute read and write commands for the CPU.
ONLINE	Tape drive mode in which the drive is able to communicate with the CPU.
PE	Phase-Encoded recording format; allows 1600 cpi and single-track error detection and correction.
PROTOCOL	The set of commands which manages the transfer of data from one device to another.
QUEUE	A lineup of operations or commands waiting to be executed.
READ/WRITE HEAD	See <i>HEAD</i> .
SELFTEST	A sequence of small test programs the drive executes when you turn it on. These programs check that the drive is functioning correctly.
START/STOP OPERATION	Intermittent data flow, as opposed to streaming operation.
STREAMING OPERATION	Continuous data flow to or from the tape drive, as OPERATION opposed to start/stop operation.

SUPERBLOCK	A block size of approximately 60 kilobytes used by the HP 7980XC when writing in "Extra Capacity" format. The normal block size is 16 kilobytes.
TAPE COLLAR	A protective, plastic circle that fastens around the tape and holds the tape in place.
TRANSFER RATE	The rate at which data is transferred from one device to another.
UNLOAD	A rewind sequence where all the tape is wound back onto the supply reel.
WRITE ENABLE	To enable writing to tape; the tape is not write-protected.
WRITE ENABLE RING	A ring installed on the back of tape reels. When the ring is in place, you may record data on the tape; when the ring is removed, data may not be written to the tape (tape is write-protected).
WRITE-PROTECT	To protect data on the tape from being erased or overwritten; the tape is write-protected if the write-enable ring is removed from the back of the tape reel.
6250XC	Another term used for EXTRA CAPACITY. See EXTRA CAPACITY.



Order Part Number

88780-90010

E0590

Printed in USA

Manufacturing Part Number

88780-90010

