

# MDCP88

## CO-PROCESSOR

---

USER'S GUIDE  
& INSTALLATION  
INSTRUCTIONS

# MORROW

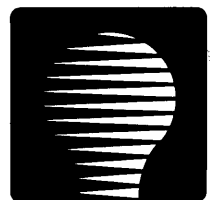

Copyright (C) 1984 by Morrow Designs, Inc.

All rights reserved.

---

No part of this publication may be reproduced, transmitted, transcribed, stored in a retrieval system, or translated into any language or computer language, in any form or by any means, electronic, mechanical, magnetic, optical, chemical, manual or otherwise, without prior written permission of Morrow Designs.

---

**DISCLAIMER**

No representations or warranties, express or implied, are made with respect to the contents hereof, including, but not limited to, the implied warranty of merchantability or fitness for a particular purpose. Further, Morrow Designs Inc. reserves the right to revise this publication and to make changes from time to time in the content hereof without obligation to notify any person of such revision.

---

Morrow  
600 McCormick St.  
San Leandro, CA 94577

## **IMPORTANT WARRANTY INFORMATION**

### **LIMITED WARRANTY**

Morrow Designs, Inc. warrants its products to be free from defects in workmanship and materials for the periods indicated below. This warranty is limited to the repair and replacement of parts only.

This warranty is void if, in the sole opinion of Morrow Designs, Inc., the product has been subject to abuse or misuse, or has been interconnected to other manufacturer's equipment for which compatibility has not been established in writing.

Circuit boards - Parts, including the printed circuit board, purchased as factory assemblies, are warranted for a period of ninety (90) days from the original invoice/purchase date.

Electro-mechanical peripherals - Peripheral equipment such as floppy or hard disk drives, etc., not manufactured by Morrow Designs, Inc., are included in the limited warranty period of 90 days from the original invoice date when sold as part of a Morrow system.

Exception - Expendable items such as printer ribbons, software media, and printwheels are not covered by any warranty.

Software/Firmware - Morrow Designs, Inc. makes no representations or warranties whatsoever with respect to software or firmware associated with its products and specifically disclaims any implied or expressed warranty of fitness for any particular purpose or compatibility with any hardware, operating system, or software/firmware. Morrow Designs, Inc. reserves the right to alter or update any program, publication or manual without obligation to notify any person of such changes.

**LIMITATION OF LIABILITY:** THE FOREGOING WARRANTY IS IN LIEU OF ALL OTHER WARRANTIES, EXPRESSED OR IMPLIED, INCLUDING, BUT NOT LIMITED TO, THE IMPLIED WARRANTIES OF MERCHANTABILITY AND FITNESS FOR A PARTICULAR PURPOSE. IN NO EVENT WILL MORROW DESIGNS, INC. BE LIABLE FOR CONSEQUENTIAL DAMAGES EVEN IF MORROW DESIGNS, INC. HAS BEEN ADVISED OF THE POSSIBILITY OF SUCH DAMAGES.

### **WARRANTY RETURN PROCEDURE**

Should a buyer experience a defect in either workmanship or materials during the warranty period, any Morrow Authorized Service Center will replace or repair the product at its expense only if the product is promptly returned to the dealer or Service Center with dated proof of purchase.

Should factory repair be necessary, the Service Center shall contact Morrow Customer Service for a Return Materials Authorization (RMA) number.

# T A B L E   O F   C O N T E N T S

---

NOTE: The Appendix (Installing the Coprocessor Board) has its own Table of Contents following page 26.

1.	<b>INTRODUCTION: WHAT THIS MANUAL IS AND ISN'T.</b>	1
2.	<b>TWO WAYS TO GO</b>	1
3.	<b>START WITH A COPY.</b>	2
4.	<b>RAMDISK: MEMORY USED AS A DISK (MD-3 ONLY)</b>	3
4.1	Trying Out Ramdisk	4
4.2	<u>EXAMPLE:</u> Using Ramdisk as a NewWord Working Disk	5
4.2.1	Creating a new file directly on a floppy	5
4.2.2	Revising an existing file on the ramdisk	6
4.2.3	If your coprocessor board has only 128K.	7
4.3	RAMDISK's Options.	8
4.3.1	Drive Name to Assign to Ramdisk.	8
4.3.2	RAMDISK and Morrow's Virtual Drive	9
4.3.3	Erase File Directory?.	10
4.3.4	RAMDISK Load Address	10
4.3.5	Loading RAMDISK Above CP/M	11
4.3.6	Co-Power 88 Port Address	12
4.3.7	Command Line Shortcuts for Options	13
4.3.8	If Things Don't Work	13
5.	<b>MS-DOS AND THE MICRO DECISION.</b>	15
5.1	What You CAN Do.	15
5.2	What You CAN'T Do.	15
5.3	What's In This Section of the Manual	15
5.4	How to Load MS-DOS	15
5.4.1	The TIME and DATE Prompts.	17
5.5	Backing Up Diskettes with MD-3's	17
5.6	Copying the Software to the <u>Hard Disk</u> .	19
5.6.1	Copying SuperCalc 2 to the Hard Disk	19
5.7	Exiting from MS-DOS.	20
5.7.1	Hard Disk Users: REMEMBER TO PARK	20
5.8	Differences in MS-DOS.	20
5.8.1	Missing Programs	20
5.8.2	Command Editing Keys	21
5.8.3	ROM Function Keys.	22
5.8.4	Additional Options for FORMAT.	22
5.9	Finding Software for Your Coprocessor.	22
5.9.1	Coprocessor Software Currently Available	23
5.9.2	Installing MS-DOS Software for Your Terminal	26
5.10	Installing SuperCalc-2	26
5.11	Running SuperCalc-2.	26

# SOFTWARE GUIDE FOR USING THE MDCP88 COPROCESSOR BOARD

## 1. INTRODUCTION: WHAT THIS MANUAL IS AND ISN'T

This documentation was produced by Morrow for use with the MDCP88 Coprocessor Board. This section covers booting and running MS-DOS, and the use of the Coprocessor as a ramdisk (MD-3 only).

Appendix A, which follows, describes installing the Coprocessor Board. It is intended primarily for Morrow dealers. (There are no other appendices, as the "A" might suggest.)

You will have also received one or two MS-DOS manuals, depending on who printed them. They provide the complete details on MS-DOS. This manual gives only a brief introduction. Finally, you should have a SuperCalc 2 manual as well.

## 2. TWO WAYS TO GO

There are two ways that you can use your coprocessor board: as a ramdisk with CP/M (MD-3's only) and as a 16 bit processor with MS-DOS. Using your coprocessor board either way is as simple as typing one CP/M command at your terminal.

When used as a ramdisk, a coprocessor board with 256K of ram provides as much storage as two-thirds of a double sided floppy disk, but with much faster access.

Second, while using the coprocessor board as a 16 bit processor, your Micro Decision becomes operating system compatible with IBM PC's running MS-DOS. This means that you can use any of the software written for PC's that does not rely on special hardware, that is, bit-mapped graphics or IBM's proprietary ROM. A list of one vendor's software for the Coprocessor is given in section 5.9.

**NOTE:** You can not use the coprocessor board as a ramdisk AND run MS-DOS simultaneously. Also, since the MD-5/11/16/34 hard disk series already employ an "intelligent" ramdisk, the ramdisk has not been designed to work with hard disk Micro Decisions.

- o The first portion of this guide explains how to use the coprocessor board as a ramdisk. There are several subtle differences in how you can use the ramdisk which are explained here.
- o The second portion of the guide demonstrates how to use the coprocessor board with MS-DOS. This information is a necessary supplement to the MS-DOS manual that you received.

If you have an MD-3, we suggest that you start by learning about the ramdisk before trying MS-DOS. The ramdisk has the advantage of being almost completely familiar territory. MS-DOS 2.1 is presumably new for you, so it has a higher frustration potential and is better handled last. However, if you really want to start with MS-DOS, or have a hard-disk Micro Decision, follow the directions in "Start with a Copy", then skip ahead to "MS-DOS and the Micro Decision".

### 3. START WITH A COPY

Before you start using your ramdisk or MS-DOS, we want you to run a "submit" program that copies some files onto your current system disk from one of the Coprocessor disks.

Copying distribution diskettes is the Standard Operating Procedure for any new software. With MD-3's, the files will go on your normal CP/M System diskette. With hard-disk MD's, the files will go in user number 0 of your hard disk.

Locate the MDCP88 Diskette whose label reads:

#### **MDCP88 MS-DOS Loader / Ramdisk Distribution Diskette**

1. To start off, turn on your Micro Decision and load the CP/M operating system in the usual way. If you are using the Co-Pilot Menus, please ESCape to CP/M by pressing the ESC key at the Co-Pilot Main Menu. The screen should show "A>", without any numbers next to the A. (Type user 0 and RETURN if there is a number present.)
2. Insert the MS-DOS / Ramdisk Distribution diskette in your B: drive and close the door. For MD-3 owners, this is the upper drive. The lower drive holds the normal CP/M System diskette.

3. At the "A>" prompt, type the appropriate command below, followed by RETURN:

MD-3's - **submit B:3**

Hard-disk MD's - **submit B:HD**

4. When the "A>" reappears, take the MS-DOS / Ramdisk Distribution Diskette out of drive B: and put it away in a safe place.

\* \* \* \* \*

NOTE TO HARD-DISK OWNERS: A few moments after entering "SUBMIT B:HD", you'll be told to switch to the MS-DOS Distribution Disk. MS-DOS is automatically loaded and some copying occurs. When that's done, "A>" appears on the screen. This is MS-DOS's System Prompt, NOT CP/M's. You could now proceed to copy SuperCalc to the hard disk (section 5.6) or run other MS-DOS utilities. To return to CP/M, type:

**z80**

and hit RETURN. Ignore the message that tells you to insert a CP/M system disk. Just hit RETURN again and you're back to CP/M.

\* \* \* \* \*

The most probable thing that can go wrong during this phase is a failure due to running out of space on your CP/M System disk. This wouldn't normally happen, but if it does, you'll have to make room on it by erasing unneeded files. If you're familiar with CP/M, you'll know that there are several alternative solutions which we won't go into.

#### **4. RAMDISK: MEMORY USED AS A DISK (MD-3 ONLY)**

Depending on the option you've selected, the coprocessor board in your Micro Decision has either 256K or 128K of memory. This memory is available for use by running the CP/M RAMDISK program. The RAMDISK program prepares the coprocessor board and makes small changes to CP/M that add the coprocessor board's memory as if it were an extra ultra-fast disk drive.

These changes to CP/M remain in effect until you reset or turn off your Micro Decision.

The most noticeable change after running RAMDISK is that you have one more drive. This drive differs from your floppy drives in that it is very fast. There are no heads to move over a track, no slowly spinning disks to wait for. Information is stored in Random Access Memory, ram.

**NOTE:** There is no way to permanently save files on the ramdisk. The ramdisk forgets everything when the power goes off unless you remember to copy its files to other "real" disks.

#### 4.1 Trying Out Ramdisk

With a copy of the RAMDISK.COM program now present on your CP/M System disk (thanks to the "submit 3" command), you're ready for a test drive. Next to the "A>", type:

```
ramdisk * (hit RETURN)
```

The RAMDISK program will first display a copyright notice, and then will silently prepare the coprocessor board and CP/M for use as a ramdisk. When this process has been successfully completed, RAMDISK produces a report briefly explaining what has been done:

```
Logical drive#.....M:  
CoPower_88 port#...0E,0F  
Load address.....D800  
File directory.....erased
```

You now have a ramdisk with logical drive name M:. The last line of the report tells you that the ramdisk's directory has been erased. Type the commands in bold below (screen responses are shown without bold):

```
A>dir m:  
NO FILE  
A>stat m:  
Bytes Remaining On M: 252k  
A>
```

Well, CP/M obviously believes that there's a drive called "M:" out there with no files presently on it. These are exactly the responses you'd get from a blank medium-capacity floppy disk.

Coprocessor boards with 256k of memory installed have 252 kilobytes available for file storage. If your coprocessor board has only 128K of memory, 124K is available as a ramdisk, but you'll find that the usefulness of a 124K ramdisk is fairly limited.

Next, try copying something onto the ramdisk:

```
A>pip m:=pip.com  
A>dir m:  
M: PIP      COM  
A>
```

This copies the PIP.COM program onto ramdisk drive M:.



One good way to use your ramdisk is for temporary storage of programs or data. For example, you can copy NewWord programs from your NewWord Working disk onto the ramdisk. You will then notice a significant increase in speed while using NewWord.

Remember, if you create or edit any files on your ramdisk, you MUST "pip" them onto a regular floppy in drive A: or B: before you turn off your Micro Decision.

#### 4.2 **EXAMPLE:** Using Ramdisk as a NewWord Working Disk

NOTE: This example will work satisfactorily only for coprocessor boards with 256K ram.

This procedure will have an enormous impact on the speed of many aspects of word processing. You'll still be limited by your typing speed, of course. But operations that normally require disk accesses will now be nearly instantaneous.

1. Insert a NewWord Working Diskette in drive B: (upper drive), and your CP/M System Diskette with RAMDISK.COM in drive A:.
2. If you've been using the menus, escape to CP/M by pressing the ESC key. "A>" should be on your screen.
3. Type **RAMDISK \*** and press RETURN.
4. When the "A>" reappears, type **PIP M:=B:NW\*.\*** and press RETURN.
5. With systems that use an MDT-60 / MT-70 terminal and KEY.COM for function keys, also type **PIP M:=B:KEY.COM**.

The NewWord programs have now been loaded onto the ramdisk. Coprocessor boards with 256K RAM will have about 120K left for documents (those with only 128K will not have room even for NewWord programs). If you want to create or revise documents on the ramdisk, you'll have room for about 25 pages of single-spaced text.

Your next step depends on a couple of things. If you want to edit an existing file, you can work on it directly on its diskette or copy it onto the ramdisk too and work on it there. Likewise with a new file: You can create it on a diskette or create it on the ramdisk. Just be aware that if you create or edit a file on the ramdisk you must copy (pip) it onto a floppy after saving it!

#### 4.2.1 Creating a new file directly on a floppy...

6. Insert the diskette that should hold the new file into drive B: (upper drive). Close the latch.

7. At the "A>" prompt, type

A>M: (and RETURN)  
M>NW (and RETURN) or KEY NW

The command you use at the "M>" prompt depends on whether you're using KEY.COM to program your function keys.

8. NewWord now begins, much faster than normal. At its Opening Menu, select D. At the file name prompt, respond B:FILENAME.

Your new file will now be placed onto the diskette in drive B: whenever you save it with a CTRL-K command.

9. When you're all done with NewWord on the ramdisk, press the Micro Decision's RESET button.

#### 4.2.2 Revising an existing file on the ramdisk...

Editing files on the ramdisk has definite speed advantages when scrolling, finding and replacing, and saving. The down side is that the file is completely temporary until you copy it from the ramdisk onto a floppy. The procedure below covers all the necessary steps.

6. Insert the diskette with the file to be edited into the B: (upper) drive. Close the latch.

7. At the "A>" prompt, type these commands, following each with a RETURN:

A>PIP M:=B:FILENAME (substitute actual file name)  
A>M:  
M>NW or KEY NW

8. NewWord now begins. Your file should appear in its directory list. Type D to open the file for editing.

9. Eventually you'll save the edited file on the ramdisk. Use ^KX.

10. At the "M>" prompt, type A:PIP B:=FILENAME. This replaces the older version of the file on the floppy in drive B: with the newly revised version. The file is now safely and permanently saved.

11. You can continue performing other ramdisk operations, or you can press the Micro Decision's RESET button to return to normal non-ramdisk operation.

### 4.2.3 If your coprocessor board has only 128K...

For one thing, you can always upgrade it later if you find that you really like using RAMDISK. But in the meantime, you can still put it to use.

A typical application would be similar to what we did in the examples above, namely, you could RUN NewWord from a floppy without copying it onto the ramdisk. But you would work on documents that are on the ramdisk. There is plenty of room for just documents (25 pages or so). You'll note great speed advantages when moving around in the file, finding/replacing, and saving.

1. Follow steps 1 - 3 from the example above. Every command is followed by a RETURN.
2. If you'll be editing an existing file that's on the NewWord Working disk in drive B:, type:

**PIP M:=B:FILENAME** (substitute actual filename)

- OR -

If you will be editing an existing file that is NOT on either the CP/M System disk OR the NewWord Working disk, type this command:

**PIP M:=C:FILENAME** (substitute actual filename)

You'll be told to switch diskettes in the lower drive twice. Put in the disk that holds the file to be edited; after it's been copied onto the ramdisk, switch back to the CP/M System disk. "A>" reappears.

3. Use this sequence of commands. Your typing is shown in bold; screen responses are shown without bold.

**A>B:**

**B>NW** or **KEY NW** for MDT-60/MT-70 systems with KEY.COM

4. NewWord's Opening Menu appears. Type **L** to log onto a different disk. Give **M** (ramdisk) as the drive to log onto. If you're working on an existing file that you pipped in step 2, it will now appear in the directory list.
5. Type **D** to open a new or existing file. Proceed with editing as usual. Save the file when finished with **^KX**. "**B>**" appears.
6. The file is now saved on the ramdisk only. For permanent storage on a diskette, type **PIP B:=M:FILENAME** to copy it onto the NewWord Working disk in drive B:, or **PIP C:=M:FILENAME** to save it on some other disk.

### 4.3 RAMDISK's Options

By typing an asterisk (\*) after the RAMDISK command, you selected RAMDISK's default options. You can also run RAMDISK interactively by entering the command without the asterisk, and select your own options.

The RAMDISK program will allow you to choose: the logical drive name, whether to erase the directory, the ramdisk driver load address and the port address. The sections that follow explain what all this means. If you aren't interested in RAMDISK's options, you can skip ahead to "MS-DOS and the Micro Decision."

You can select the default for any of RAMDISK's four options by pressing RETURN after the question instead of typing an answer.

#### 4.3.1 Drive Name to Assign to Ramdisk

RAMDISK allows you to assign the ramdisk to any legal CP/M drive name, that is, from A: to P:.

As you have noticed, the default drivename is M:. You can even use the drive name of an existing disk drive, in which case a (possibly) confusing thing occurs. The drive names of disk drives that come "after" the drive name you have chosen are moved up one place alphabetically. For example, if you decide to make the ramdisk your B: drive, then your current B: drive is reassigned to be drive C:. Your floppy disk drives are now named A: and C:, and the ramdisk is named B:.

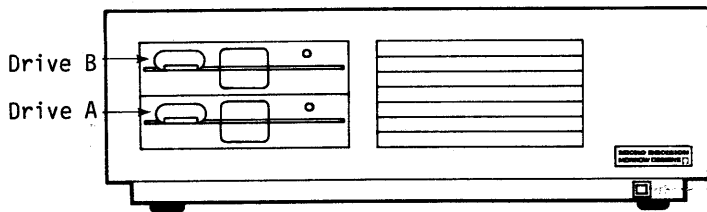

Ramdisk as Drive M:

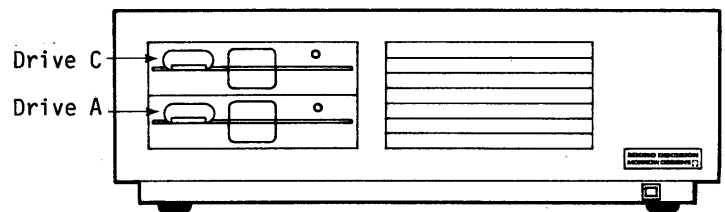

Ramdisk as Drive B:

If you assign the ramdisk to be drive A:, an even more interesting thing occurs. Your current drive A: becomes drive B: and drive B: becomes drive C:. The ramdisk is named drive A: AND the CP/M operating system is copied to the ramdisk. This means that all future warm boots (the thing your computer does when you type control-C and programs do when they end) are done from the ramdisk instead of floppy drive A:, greatly speeding up warm boot operations.

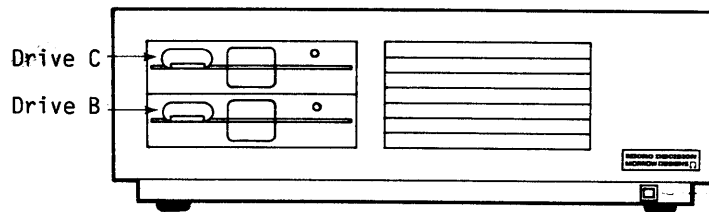

MD-3 with Ramdisk as Drive A:

#### 4.3.2 RAMDISK and Morrow's Virtual Drive

The Micro Decision is designed so that you can define virtual drives. If you ask for the directory of the fourth drive, D:, of a two drive MD-3, the Micro Decision will ask you to insert a disk into the lower drive and press RETURN. From now until you request something from drive A:, your lower drive will be drive D:, an imaginary fourth drive. (You should read the Micro Decision User's Guide if you want to find out more about virtual drives).

When you use the RAMDISK program, CP/M is modified to work with the ramdisk. In particular, if you make your ramdisk drive A: or B:, your disk drives' names are reassigned as far as CP/M goes. But, Morrow's virtual drive is NOT a part of CP/M. Running RAMDISK and reassigning your disk drive names does NOT affect the part of the Micro Decision that handles virtual drives. So, the messages that you get when you use a virtual drive are not changed by the use of the ramdisk as drive A: or B:.

This is best shown by trying an example.

Suppose you've run the RAMDISK program on your MD-3, and made the ramdisk Drive A:, and RAMDISK reassigns your two floppy drives as B: (bottom drive) and C: (top). So, "dir a:" shows the directory of the ramdisk, "dir b:" displays the directory of the bottom floppy disk, and "dir c:" of the top one. What happens when you try to use virtual drive D: by entering "dir d:"?

Without ramdisk, your Micro Decision would respond:

Your lower drive is being re-assigned as drive D.  
Exchange diskettes and press [RETURN] to continue

With ramdisk as drive A:, your Micro Decision responds:

Your lower drive is being re-assigned as drive C.  
Exchange diskettes and press [RETURN] to continue

Your Micro Decision is unaware of the changes made by the RAMDISK program. Even though you typed "dir d:", the Micro Decision interprets this as "get the directory of the THIRD drive" which is usually drive C:.

This may be still confusing to you, but the best remedy is to try it out yourself. Just remember: the messages that you see about virtual drives will refer to the drive name that is one letter "before" the one you requested.

#### **4.3.3 Erase File Directory?**

The first time you run RAMDISK after turning on your Micro Decision, the coprocessor board's memory is full of random bits. Erasing the file directory cleans up the directory of the ramdisk, making it ready for use. You will ALWAYS want to erase the ramdisk's file directory after turning on your Micro Decision. Erasing the directory of the ramdisk is the default which you get by using the asterisk or pressing RETURN.

The reason for this option is that it allows you to press the RESET button on your Micro Decision without automatically erasing your ramdisk. For example, if you have written a program that crashes, the way that you regain control of the Micro Decision is by pressing reset.

By specifying "No" to the erase file directory option, the contents of your ramdisk will be intact after resetting the Micro Decision. Your ramdisk will retain its memory until you: 1) erase its directory, 2) turn off the Micro Decision, or 3) run MS-DOS.

#### **4.3.4 RAMDISK Load Address**

The Load Address is the physical address in the Micro Decision's ram where the RAMDISK program is loaded. Unless you are familiar with the internal workings of CP/M, you should use the default address provided by the RAMDISK program. However, you may profit by reading this section if you want to know more about CP/M and one of your programs complains that it's "Out of Memory" after you run RAMDISK.

The default value for the Load Address in an MD-3 is D800. This address is 1k below the bottom of the Console Command Processor, or CCP. CP/M is designed so that the CCP, which interprets keyboard commands until a program is run, can be overwritten by that program. Warm booting CP/M reads the CCP back into memory. With the RAMDISK program loaded below the CCP, the CCP can no longer be overwritten by programs. This reduces the space available to programs (called the TPA) by the size of the CCP (2k) and the size of RAMDISK (1k). So, with RAMDISK, the TPA is 3k smaller.

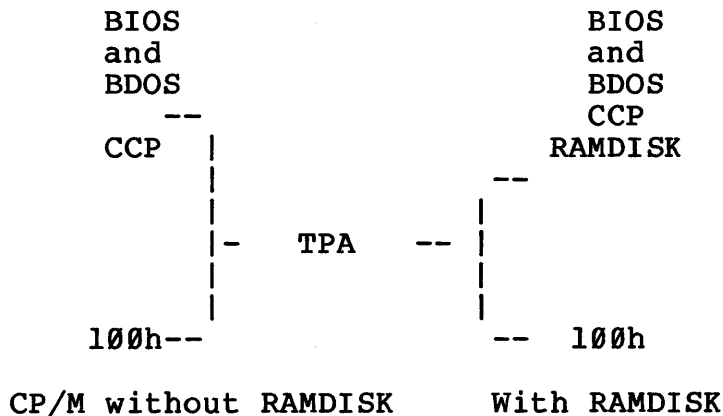

If you want to use RAMDISK, you must lose at least 1k for the RAMDISK program itself. But, you can avoid the loss of the additional 2k of the CCP by loading RAMDISK above CP/M. You do this by creating a CP/M system disk that has 1k of free space above the BIOS and specifying the RAMDISK load address there.

#### 4.3.5 Loading RAMDISK Above CP/M

There are many steps in doing this the first time, but once you've created the special CP/M system diskette, things get much easier. Essentially, you create a 63k CP/M system, copy it to a diskette and initialize the CP/M system. Once this diskette is prepared, you use it, or a copy of the CP/M system on it, to load RAMDISK above CP/M.

1. You will need two diskettes, one blank, the other with a CP/M system on it. On the diskette with the system, you also need the following programs: MOVCPM, SYSGEN, RAMDISK and PIP. Put this diskette in your A: drive and reset the Micro Decision.
2. Find the master CP/M Distribution diskette that came with your Micro Decision (or MD-3 upgrade kit) and insert it into your B: drive. This diskette has several programs on it that you probably do not have anywhere else. To copy these programs to the diskette in drive A:, type

```
pip a:=b:init.*
```

Once this operation has completed, remove the Distribution diskette and return it to a safe location.

3. Next, the MOVCPM program is used to create a 63k CP/M. Type

```
movcpm 63 *
```

and the MOVCPM program will create an uninitialized CP/M system in memory.

4. The SYSGEN program is used to copy the 63k CP/M from memory to a diskette. Simply type

#### **sysgen**

When you are asked which drive to read the system from, (SOURCE), press RETURN because the system you want is already in memory. Type an "A" for the destination drive. When the process is complete, press the reset button to restart the Micro Decision.

5. You now have an uninitialized 63k CP/M system on the diskette in drive A. You might have noticed that the copyright line has changed to reflect this. To initialize this diskette, insert your blank diskette in drive B, type

#### **init**

and follow instructions. The INIT programs format the blank diskette, copy the diskette in drive A to it, allow you to configure it for the number of disk drives and type of terminal, and finally erase themselves from it. This is why you must copy the INIT programs from the master diskette.

6. Remove the diskette from drive A and label it: 63K Configuration Diskette. Remove the diskette from drive B and label it "63K CP/M". Now you can pip RAMDISK.COM onto this diskette, and load RAMDISK above CP/M by typing the command

#### **ramdisk ,,FC00**

Anytime you want to load ramdisk above CP/M, boot your Micro Decision with the 63k CP/M diskette, and type "ramdisk ,,FC00". Don't forget the commas. We'll explain them later.

#### **4.3.6 Co-Power 88 Port Address**

This is one option that you will NEVER use. The port address is physically wired into your coprocessor installation as 0E hexadecimal, and cannot be changed. If you select another port address, the coprocessor will not work.



### 4.3.7 Command Line Shortcuts for Options

We've actually shown you several examples where we included options on the command line, for example:

```
    ramdisk *
    ramdisk a
and  ramdisk ,,FC00
```

The RAMDISK program will interpret the command line that you give it, allowing you to select options without answering the four questions. A comma by itself means "use the default value". If you specify less than four values, the defaults are used for the remaining options.

When you use this shorthand method, the order of the questions remains the same, that is:

```
    Drivename (A thru P) to assign to ramdisk
    Erase contents of ramdisk file directory (Y/N?)
    Ramdisk driver load address
    CO-POWER-88 port address
```

In our first example, `ramdisk *`, the asterisks means "use all the defaults". The second example, `ramdisk a`, means assign the drivename "A" to the ramdisk and use the other three defaults. The final example, `ramdisk ,,FC00`, means select the defaults for the first two questions, use `FC00` as the load address, and use the default for the port address.

### 4.3.8 If Things Don't Work ...

The RAMDISK program has been successfully loaded when you see the report that tells you which drivename was selected, etc. If you don't see this report, you probably got an error message instead. The RAMDISK program has three error messages to cover types of errors that it can detect, which are explained below.

#### **\*\*\* invalid parameter in command line \*\*\***

This message is produced when you included something on the RAMDISK command line (see Command Line Shortcuts) that RAMDISK can't understand. The legal parameters for the four questions are:

1. Drivenames can only be the letters A thru P;
2. Erase directory can only be answered with Y or N;
3. The load address must be a valid hexadecimal number, that is, the digits 0 thru 9 and the letters A thru F. The load address must also be on a 256 byte boundary and be greater than the address of the beginning of the BIOS;

4. The port address must be a valid hexadecimal number less than 256. You should always use the default value, 0E, with your Micro Decision. A comma on the command line is sufficient, or a RETURN when answering interactively.

If RAMDISK has trouble accessing the coprocessor board, you will get the message

**\*\*\* cannot load, 8088 does not respond \*\*\***

You may get this message if you have previously been using the coprocessor with MS-DOS, or have tried to load the ramdisk and failed. The solution in this case is to reset the Micro Decision with the RESET button. This also resets the 8088, curing the problem. (Dealers: if this occurs immediately after the coprocessor is installed, check the data and power cable connections).

The third message can only occur when you try to use the ramdisk as drive A. The RAMDISK program locates your copy of CP/M in memory and attempts to copy it to the ramdisk. Then, it checks this copy for correctness. If the test for correctness fails, you will see the message

**\*\*\* not standard CP/M system, cannot load \*\*\***

You should only get this message if you have directly modified CP/M, or run a program that modifies CP/M. Of course, the RAMDISK program itself does this, and running RAMDISK a second time without resetting will produce this message. Always reset your system after getting this message if you intend to use the ramdisk.

## **5. MS-DOS AND THE MICRO DECISION**

The Coprocessor board turns your Micro Decision into a 8088-based MS-DOS system with the use of a single CP/M command.

### **5.1 What You CAN Do**

While using MS-DOS, your Micro Decision can format, read, and write MS-DOS diskettes, and run software written for MS-DOS. For example, files generated by a wordprocessor on an IBM PC can also be edited on the Micro Decision.

### **5.2 What You CAN'T Do**

You cannot use programs written specifically for PC DOS, IBM's version of MS-DOS. These are programs that assume you have a bit-mapped monitor, and/or programs that make PC ROM calls.

You also cannot read or write CP/M diskettes while operating MS-DOS. This is because the organization of CP/M and MS-DOS diskettes is as great as the difference between English and Japanese.

### **5.3 What's In This Section of the Manual**

This guide will explain in detail the two steps involved in loading MS-DOS. We will also explain how to make backups of your master diskettes, and the differences between MS-DOS for the Coprocessor and general-purpose MS-DOS.

The last part of this section tells you how to run SuperCalc II, which come preinstalled for your Micro Decision, and how to select and install other MS-DOS software for the Coprocessor.

### **5.4 How to Load MS-DOS**

Loading MS-DOS begins in a totally familiar way: you turn on your Micro Decision and load the CP/M operating system. If you have a hard-disk Micro Decision, this process is automatic.

For those of you with MD-3's, you must insert your CP/M System diskette or other "bootable" diskette into the A: drive first. Use the system diskette that contains the program MSDOS.COM, which you copied back in section 3, "Start With A Copy".

If any of you skipped that section of the Guide, turn back a few pages and do it now. Then, with a copy of MSDOS.COM on your A: drive, you are ready to begin.

1. At the "A>" prompt, type **msdos**, followed by a RETURN.

If you get the response "File not found", MSDOS.COM must not be on the diskette in drive A (or user 0 of your hard disk). Please go back to "Start with a Copy".

If you hear some disk activity, but nothing happens on your screen, press the RESET button on your Micro Decision and try typing **msdos** at the "A>" prompt again.

2. Some instructions have appeared on your screen, beginning with

Place MSDOS disk in drive

What you need to do next is based on whether you have an MD-3 or a hard-disk MD.

MD-3:

Remove any CP/M diskettes that you may have in either disk drive. Then insert into the lower (A) drive the diskette labeled

**Microsoft MS-DOS version 2.11  
Copyright 1981,82,83 Microsoft Corp.**

Close the drive door, and press RETURN. This tells the MSDOS.COM program to boot MS-DOS from drive A.

The same two lines that appear on the diskette label will be displayed on your terminal. If they aren't, you are probably using the wrong diskette. Find the correct one, and start over by resetting your Micro Decision, booting with the CP/M System disk containing MSDOS.COM, and then typing **msdos** followed by a RETURN.

Hard-disk models:

No disk swapping is required for booting MS-DOS. Just hit RETURN.

### 5.4.1 The TIME and DATE Prompts

After it's loaded by MSDOS.COM, MS-DOS first asks you to enter the current date and time. The date and time are used by MS-DOS to stamp disk files with the time and date they were most recently changed. Your Micro Decision does not, unfortunately, contain a clock, so all files will be stamped with whatever time and date you have most recently typed; the time is not updated until you boot MS-DOS again and re-enter the time and date. Entering the date and time is explained in section 2.2 of the MS-DOS 2.0 User's Guide, but here is an example you can use:

```
Command v. 2.11
Current date is Tue 1-01-1980
Enter new date: 5-30-84 (press RETURN)
Current time is 0:00:00.00
Enter current time: 16:00 (press RETURN)
```

A> <--- This is now MS-DOS's system prompt, NOT CP/M's.

**NOTE:** Unless you have a practical reason for date-stamping files (like using a backup program that looks for such information), you can simply press RETURN at the DATE and TIME prompts.

### 5.5 Backing Up Diskettes with MD-3's

If you're using a hard-disk MD, skip ahead to the next section.

Once you have the MS-DOS "A>" prompt on the screen, you are ready to make backup copies of the MS-DOS diskettes that came with your Coprocessor.

Formatting and copying MS-DOS diskettes can only be done while you are running MS-DOS. MS-DOS has its own set of routines for formatting and copying, similar to but distinct from those used by CP/M. The CP/M copy programs, PIP.COM and BACKUP.COM, won't work here. Likewise, CP/M's FORMAT.COM that you've been using for Micro Decision diskettes will NOT work for MS-DOS diskettes.

CP/M program/command = MS-DOS program/command

DIR  
STAT.COM or SHOW.COM  
PIP.COM  
BACKUP.COM  
FORMAT.COM

DIR  
DIR and CHKDSK.COM  
COPY  
DISKCOPY.COM  
FORMAT.COM

Before you can continue with this section, you will need two new blank soft-sectored diskettes. **These diskettes are exactly the same type as those you already use with your Micro Decision.** Add one of the following labels to these diskettes:

**MS-DOS System Diskette**

and

**MS-DOS SuperCalc-2 Working Diskette**

Keep these straight in your mind - don't confuse them with your CP/M System diskette that has the CP/M programs RAMDISK.COM and MSDOS.COM on it.

With these labeled diskettes at hand, you are ready to begin.

1. Insert the blank diskette labeled "MS-DOS SuperCalc-2 Working Diskette" into drive B: (your upper drive), and at the "A>" prompt, type

**format b: /d** (press RETURN)

You will be instructed to insert a disk in drive B: and press any key. Go ahead and press one, since you've already inserted the diskette.

2. When the first diskette has been formatted, you will be asked if you want to "Format another (Y/N)?" You do. Remove the diskette from drive B:, insert the diskette you labeled "MS-DOS System Diskette", answer "Y" and press any key to start.
3. Once again, you have the option to format another diskette. This time, answer "N" to quit formatting. Leave the MS-DOS System Diskette in drive B:.
4. Now you are ready to copy the Microsoft MS-DOS Distribution diskette (now in drive A:) onto the freshly-formatted MS-DOS System diskette in drive B:.. Enter:

**diskcopy a: b:** (and RETURN)

and strike any key to begin the copy.

5. When the first copy completes, you will be asked if you want to "Copy another (Y/N)?" Press "Y" for yes, and remove BOTH diskettes from the drives. Insert the blank diskette labeled "MS-DOS Super Calc-2 Working Diskette" in drive B: (upper), and the SuperCalc-2 Distribution diskette in drive A:.. **Make sure the diskettes are in the correct drives.** Then press any key to begin the copy.

6. Remove the SuperCalc Distribution diskette from drive A: when the diskcopy completes, and answer "N" to the "Copy another" prompt. Insert the "MS-DOS System Diskette" diskette into drive A: and you are ready to go.

You now have working copies of all of the software that you received with your Micro Decision. Take the Distribution diskettes and put them away in the safe place where you keep your other one-of-a-kind master diskettes. For running and installing SuperCalc, see sections 5.10 and 5.11.

You may wish to make more copies of the two working diskettes at this time. Just follow the six steps outlined above, using the working diskettes as the source instead of the masters.

## 5.6 Copying the Software to the Hard Disk

When you first load MS-DOS files onto your hard disk with the HD.SUB submit program, a CP/M file is created. It appears in the directory as "MSDOS.FIL." What CP/M doesn't know is that this file is really a bunch of MS-DOS files, like COMMAND.COM and FORMAT.COM.

When you boot MS-DOS, what appeared as a single file to CP/M is now shown to be your whole MS-DOS file system. When you create new MS-DOS files or COPY others onto the hard disk, they'll appear as distinct entries with an MS-DOS DIR command. When you're back in CP/M, the only apparent effect is that MSDOS.FIL has grown in size.

How much space is available for MS-DOS files? In other words, how big can MSDOS.FIL be? There is no limit beyond the storage capacity of your hard disk.

### 5.6.1 Copying SuperCalc 2 to the Hard Disk

In this operation, you will copy the SuperCalc 2 files from the SuperCalc Distribution Diskette onto the hard disk. When you're running MS-DOS, a DIR command will show specific files like SC2.EXE. When you're running CP/M, the only evidence of SuperCalc's presence is an enlarged MSDOS.FIL.

The commands used below apply to any MS-DOS software.

1. Start MS-DOS by typing `msdos` at the CP/M "A>" prompt (section 5.4). Proceed through the time and date prompts, until MS-DOS's "A>" prompt appears.
2. Insert the **SuperCalc 2 Distribution Diskette** into the floppy drive and close the latch.
3. At the A> prompt, enter `copy B:*. * A:` and hit RETURN. When the copying is finished (A> returns), put the SuperCalc disk away with the other masters. You can now run SuperCalc 2 by typing `sc2` and RETURN. See also "installing" SuperCalc in section 5.10.

## 5.7 Exiting from MS-DOS

There is a special MS-DOS command used for returning to CP/M. Hard disk owners **MUST** return to CP/M before turning off the Micro Decision so they can PARK the hard disk. Type:

**z80** (press RETURN)

at the MS-DOS A> prompt. You will be asked to place a CP/M system disk in drive A: and to press any key. MD-3 users should insert any bootable CP/M diskette in drive A: Hard-disk MD users can simply press any key.

Alternatively, you can simply push the Micro Decision's RESET button to return to CP/M. MD-3 owners need to insert a bootable CP/M diskette before or after pressing reset.

### 5.7.1 Hard Disk Users: REMEMBER TO PARK

You must return to the CP/M operating system before you turn off your computer. We want you to take care of your hard disk by using the PARK command. Follow the instructions above to return to CP/M, and enter

**park** (press RETURN)

(or select PARK from the Co-Pilot Main Menu). You may now turn off your computer.

## 5.8 Differences in MS-DOS

The version of MS-DOS that comes with the Coprocessor varies slightly from version of MS-DOS explained in the MS-DOS User Guide. In the next several sections we will tell you what those differences are. We suggest that you read these sections before going on to learn more about MS-DOS from the User's Guide. We'd also like to point out to you that there are other, friendlier books about MS-DOS available at your local computer dealer.

### 5.8.1 Missing Programs

The MS-DOS 2.0 User's Guide lists a few programs in the Package Contents list that are not part of this version. This version of MS-DOS does not come with the assembler, so the assembler's files and the Assembler and Programmer's Reference Manuals are not included. These files are named

CREF.COM    LIB.EXE    MASM.EXE



The hidden SYSTEM files are not simply hidden: they're not there. They have been replaced by the MSDOS.COM program on the CP/M disk. The MSDOS.COM program handles both the modification of CP/M and the loading of the entire MS-DOS system into the Coprocessor. The two missing system files are

IO.SYS            MSDOS.SYS

The background printing program, PRINT.COM, is also not included.

### 5.8.2 Command Editing Keys

The most recently entered MS-DOS command is saved in a storage area called the template. You can recall or edit the command saved in the template by using the command editing keys. Command editing is explained in section 6.1 of the User's Guide.

On page 6.4 of the User's Guide is a table labeled "Table 6.1 Special Editing Functions". This table has a blank column labeled "Your Keyboard". You should copy the entries in the first column of the following table to the column labeled "Your Keyboard" in the User's Guide.

Entering these keys	Performs this editing function
ESC S	Copies one character from the template to the command line.
ESC T	Copies characters up to the character specified in the template and puts these characters in the command line.
ESC U	Copies all remaining characters in the template to the command line.
ESC V	Skips over (does not copy) a character in the template.
ESC W	Skips over the characters in the template up to the character specified.
ESC E	Erases current command line without changing the template.
ESC P	Enter insert mode.
ESC Q	Exit insert mode.
<RETURN>	Enters the new command line into the template
<CTRL-Z>	Puts an end of file character (Control Z, 01AH) in the command line.

Please notice that CAPITAL letters are used with the ESCape key to perform most editing functions. If you try to use small letters, nothing will happen.

### 5.8.3 ROM Function Keys

Your MS-DOS systems supports the use of the substitution of the following keys for the IBM-PC function keys if the program uses PC ROM calls to access the keys. This is not something that you can usually find out about before buying MS-DOS software, so please don't count on this working. We include it in case it does work with your program.

<u>IBM-PC</u>	<u>USE</u>	<u>IBM-PC</u>	<u>USE</u>
F1	ESC 1	F6	ESC 6
F2	ESC 2	F7	ESC 7
F3	ESC 3	F8	ESC 8
F4	ESC 4	F9	ESC 9
F5	ESC 5	F10	ESC 0

### 5.8.4 Additional Options for FORMAT

The MS-DOS format command is explained in the User's Guide beginning on page 5-33. The following switches (options) are available in addition to the ones described in the MS-DOS User's Guide.

Switch	Function
/D	This switch is necessary for formatting double-sided diskettes. You will normally include this in your format commands.
/8	The default format has 9 sectors per track, which is standard for MS-DOS 2.0. The standard format for MS-DOS 1.25 is 8 sectors per track. Adding this switch (and the /O switch) to the FORMAT command makes the diskette MS-DOS 1.25 compatible.

## 5.9 Finding Software for Your Coprocessor

Your Coprocessor running MS-DOS has a lot in common with IBM-PC look-alikes. That is to say that you don't have the same hardware as an IBM-PC. What's not there? Well, you don't have bit-mapped graphics. And you don't have the keyboard ROM. As mentioned earlier, some of the PC ROM calls are handled correctly by this version of MS-DOS, but not all of them.

You need to look for MS-DOS (not PC-DOS) software. Some software that will work with IBM-PC look-alikes will also work for you. MS-DOS versions of CP/M programs will probably work. Anything that offers bit-mapped graphics will definitely NOT work.

On the following pages is a list of programs offered by one software vendor for use on the Coprocessor. Call Westico directly for further information. This list is provided for your convenience only; it is not a guarantee of the vendor's or the software's performance.

### 5.9.1 Coprocessor Software Currently Available

Contact:

Westico (The Software Express Service)  
 25 Van Zant St.  
 Norwalk, CT 06855  
 (203) 853-6880                      Telex 643-788

<u>Product</u>	<u>Author</u>	<u>Version</u>	<u>Item #</u>	<u>Requirements</u>
<b>ACCOUNTING</b>				
Income A/P	MC	2.4B	A034.PC	*D,I
Income A/R	MC	2.5C	A023.PC	*D,I
Income G/L	MC	2.1B	A010.PC	*D,I
Income Order Entry	MC	1.1B	A015.PC	*D,I+A032.PC
Income Purchasing	MC	1.1B	A013.PC	*D,I+A032.PC
Income Inv. Control	MC	3.2B	A032.PC	*D,I
Income Job Cost/WIP	MC	1.1A	A014.PC	*D,I+A032.PC
Inmass B.O.M.	MC	3.2C	A012.PC	*D,I+A032.PC
Inmass Materials	MC	1.0B	A016.PC	*D,I+A032.PC
TOTAL A/P	TCS	2.36	A027.MS	*I
TOTAL A/R	TCS	2.36	A026.MS	*I
TOTAL A/R(rev.3)	TCS	3.36	A071.MS	*I+A073.MS
TOTAL G/L	TCS	2.36	A025.MS	*I
TOTAL Inventory	TCS	2.36	A029.MS	*I
TOTAL Inv.(rev.3)	TCS	3.36	A073.MS	*I
TOTAL Materials	TCS	3.36	A053.MS	*I+A073orA071.MS
TOTAL Payroll	TCS	2.36	A028.MS	*I
TOTAL Sales	TCS	3.36	A057.MS	*I+A073orA071.MS
Simple	TCS	2.36	A031.MS	I
Q/Label	TCS	2.36	A055.MS	I
Total Utilities	TCS	3.36	A058.MS	I
Client Ledger Sys.	TCS	3.36	A030.MS	*I
Fixed Assets	Origin	3.94	A068.MS	*I
<b>BUSINESS MANAGEMENT</b>				
Billkeeper	Micro Craft	1.2F	B009.PC	*J
Verdict	Micro Craft	3.2F	B006.PC	*J
Audit	Mciro Craft	1.3	B015.PC	*+B006 or B009
Professional G/L	Micro Craft	2.0	B011.PC	*J
Pas-3 Medical	AI	2.1	B001.PC	*I
Pas-3 Dental	AI	1.75	B002.PC	*I
Bidsheet	Comp ForConstr	2.1	B008.MS	*I
Market Pro	AIM		B004.MS	

<u>Product</u>	<u>Author</u>	<u>Version</u>	<u>Item #</u>	<u>Requirements</u>
----------------	---------------	----------------	---------------	---------------------

### LANGUAGE PROCESSORS

BASIC MS	Microsoft	5.28	L006.MS	
IAR/6502	IAR	1.0	L045.MS	
IAR/8085	IAR	1.0	L015.MS	
IAR/6809	IAR	1.0	L014.MS	
IAR/8086	IAR	1.0	L046.MS	
IAR/AT7000	IAR	1.0	L042.MS	
IAR/A1802	IAR	1.0	L013.MS	
IAR/A6801	IAR	1.0	L025.MS	
IAR/A6805	IAR	1.0	L027.MS	
IAR/A68K	IAR	1.0	L033.MS	
IAR/A804X	IAR	1.0	L012.MS	
IAR/A8501	IAR	1.0	L011.MS	
IAR/AZ80	IAR	1.0	L026.MS	
IAR/AT99	IAR	1.0	L043.MS	
IAR/AZ6	IAR	1.0	L036.MS	
IAR/XLINK + 3	IAR	1.0	L037.MS	
IAR/XLINK + 5	IAR	1.0	L038.MS	
IAR/XLIB	IAR	1.0	L035.MS	
IAR/XLINK	IAR	1.0	L030.MS	
C Compiler MS	Microsoft	1.04	L067.MS	
M2CBASIC	Buzzwords	1.3	L004.MS	*
BASIC Compiler	Microsoft	5.35	L007.MS	
Business BASIC	Microsoft	1.0	L066.MS	
COBOL MS	Microsoft	1.07	L029.MS	
FORTRAN MS	Microsoft	3.13	L028.MS	
Janus/ADA	RR Software	1.47	L044.MS	
Pascal MS	Microsoft	1.0	L059.MS	
CB-86 Compiler	DRI	2.0	L039.IP	
Pascal/MT+86	DRI	3.2	L005.IP	
PL/I-86	DRI	1.0	L002.IP	
muLISP/muSTAR	Microsoft	2.15	L032.MS	
muMATH/muSIMP	Microsoft	2.15	L031.MS	
Macro-MS	Microsoft	1.25	L034.MS	
C86	Comp Innovations	1.32D	L047.MS	

### DATABASE MANAGEMENT

R:base 4000	MicroRim		D015.MS	*
Formula II	DMA	2.22	D004.MS	
dBase II	Ashton-Tate	2.4	D018.MS	
Condor 20-1	Condor	2.11	D022.MS	*J
Condor 20-3	Condor	2.11	D024.MS	*J
Infostar	MicroPro		D038.MS	
Datastar	MicroPro	1.41	D009.MS	

<u>Product</u>	<u>Author</u>	<u>Version</u>	<u>Item #</u>	<u>Requirements</u>
----------------	---------------	----------------	---------------	---------------------

**MISCELLANEOUS**

Electronic Circuit	Tatum Labs	1.73	E002.MS	
EM80/86 MS	DMA	1.6	M011.MS	
Conv/CP	DMA	1.3	M002.MS	
SuperSort MS	MicroPro	1.65	M001.MS	
TypeQuick MS	AID	3.14	M014.MS	

**DEVELOPMENT TOOLS**

Display Manager	DRI	1.0	T052.IP	
Access Manager	DRI	1.1	T037.IP	
Quick Code	Fox & Geller	2.2	T005.PC	+D018.MS
Assembler + Tools	DRI	1.0	T002.IP	
Vedit	CompuView	1.38	T009.MS	

**WORD PROCESSING**

WordStar	MicroPro	3.30	W003.MS	
MailMerge	MicroPro	3.30	W004.MS	+W003.MS
SpellStar	MicroPro	3.30	W009.MS	+W003.MS
WordStarProf'l.	MicroPro	3.30	W010.MS	
StarIndex	MicroPro	1.01	W001.MS	+W003.MS
Final Word	Unicorn	1.15	W022.MS	J

**PLANNING & ANALYSIS**

MicroGANTT	Earth Data	1.94A	P018.MS	
Multiplan	Microsoft	1.10	P034.MS	
ProFin	Business Soft	3.12	P067.MS	+L006.MS
PlanFin	Business Soft	3.12	P066.MS	+L006.MS
RealEst. An.	Real Data	1.1B	P156.MS	+P034.MS
RE Comm/Indtrl.	Real Data	1.1B	P155.MS	+P034.MS
StatPak	NWA	3.1	P002.MS	J+L006.MS
T/Maker III	T/Maker	3.02A	P036.MS	*

**Notes:**

(\*) low-cost demo available (I) 132-column printer required  
 (+item #) another product required (D) MD-11 required  
 (J) 80-column printer required

## 5.9.2 Installing MS-DOS Software for Your Terminal

You were asked to select a terminal from a list of terminals when you installed CP/M for the first time on your Micro Decision. If your terminal was on the list (as opposed to your having to pick "None of the above"), terminal emulation was added to your CP/M system. This means that your Micro Decision software thinks it's talking to one of one of the following three terminals:

ADM-31  
Soroc IQ-120  
ADM-3A

When you buy additional MS-DOS software, you will likely need to install it for one of these terminals, regardless of the model terminal you actually have. If you don't remember which of these terminals is being emulated, try the fanciest first. Install the software for the **ADM-31** and try it out. If your screen looks funny, or "G4" appears in strange places, you need to try the "medium" level terminal, the **Soroc IQ-120**. And, if this doesn't work, there's always the "minimal" terminal, the **ADM-3A**.

If your terminal wasn't on the list of terminals that you saw when setting up your Micro Decision, i.e. you picked "None of the above," your Micro Decision isn't using terminal emulation. Thus software must be installed for your specific terminal. If you want to create a bootable CP/M diskette without terminal emulation, copy the INIT programs from your Master diskette and run INIT (see the earlier section "Loading RAMDISK Above CP/M").

## 5.10 Installing SuperCalc-2

Here is some good news: SuperCalc-2 comes pre-installed. It assumes you have a Morrow MDT-60 or MT-70 terminal. If you have any other type of terminal, you will probably have to re-install SuperCalc.

To re-install SuperCalc-2, load MS-DOS and put the SuperCalc working disk in drive A (MD-3 only). Then type:

```
install (press RETURN)
```

Then follow the instructions for selecting a terminal as described in Appendix D of the SuperCalc-2 manual. HINT: Read "Installing MS-DOS Software for Your Terminal" above. Avoid selecting ADM-31 - go right to Soroc IQ-120.

## 5.11 Running SuperCalc-2

Load MS-DOS. Insert the SuperCalc-2 working disk in drive A: (MD-3 only). At MS-DOS' "A>" prompt, type **sc2** and press RETURN. The rest is up to you and the SuperCalc-2 manual.

A P P E N D I X    A  
C O P R O C E S S O R    B O A R D  
I N S T A L L A T I O N

NOTE: The instructions in this document were written at a very elementary level. As a result, highly experienced technicians may become annoyed at what seems like overkill. But BE AWARE that there are several places where overconfidence can seriously damage the Micro Decision. Such sections have been marked with appropriate "Caution" flags.

A.1	Qualified Installers . . . . .	1
A.2	Which Micro Decisions Can Use the Coprocessor? . . .	2
A.3	What Tools Do You Need? . . . . .	2
A.4	What's in the Box. . . . .	2
A.5	Hardware Installation Overview . . . . .	3
A.6	Park Hard Disks! . . . . .	3
A.7	Disconnect All Cables. . . . .	3
A.8	Remove the Chassis Cover . . . . .	3
A.9	Remove the Power Supply. . . . .	4
A.10	Remove the Disk Drives . . . . .	5
A.10.1	Remove The Disk Drive Cables . . . . .	5
A.10.2	Drive Removal. . . . .	6
A.11	Remove the Motherboard . . . . .	7
A.11.1	Disconnect a Few More Wires. . . . .	8
A.11.2	Motherboard Removal. . . . .	9
A.12	Install the 40 Pin Header. . . . .	11
A.13	Replace Motherboard. . . . .	12
A.14	Installing the Expansion Board . . . . .	14
A.15	Connecting the Expansion Board to the 40 Pin Header. . . . .	15
A.15.1	MD-3 Motherboard by Kohjinsha. . . . .	15
A.15.2	MD-3 Motherboard "Made in Korea" . . . . .	16
A.15.3	MD-11. . . . .	16
A.15.4	MD-3's Again . . . . .	18
A.16	Replace Disk Drives. . . . .	18
A.17	Installing the Coprocessor Board . . . . .	19
A.18	Replace Power Supply . . . . .	20
A.19	Replace the Cover and Cables . . . . .	20
A.20	Check-out Time . . . . .	21

## L I S T   O F   F I G U R E S

---

A-1	Hardware Block Diagram . . . . .	1
A-2	Bottom of Micro Decision Chassis . . . . .	4
A-3	Korean Assembled Motherboard With 40-Pin Header. . . . .	5
A-4	Disk drive mounting bracket, left side . . . . .	6
A-5	L shaped brackets securing drives. . . . .	6
A-6	Revision A chassis back panel. . . . .	7
A-7	Revision B chassis back panel. . . . .	8
A-8	Revision C chassis back panel. . . . .	8
A-9	Motherboard removal, Revision A and B chassis. . . . .	10
A-10	Motherboard removal, Revision C chassis. . . . .	10
A-11	40-pin header orientation. . . . .	11
A-12	MD-11 fan wire connection to motherboard . . . . .	13
A-13	Expansion Board and cables . . . . .	14
A-14	Installation of Expansion Board: Kohjinsha MD-3 . . . . .	15
A-15	Connection of Expansion Board: Korean MD-3. . . . .	16
A-16	Assembly of Expansion Board, MD-11 . . . . .	17
A-17	Installation of cables, Coprocessor Board. . . . .	20

## L I S T   O F   C A U T I O N S

---

Park hard disks (MD-11). . . . .	3
Avoid damage to motherboard through static discharge . . . . .	9
Inspect soldering of 40-pin header carefully . . . . .	12
Inspect connection of power wires to Expansion Board . . . . .	14
Check Expansion Board / motherboard connection (MD-3). . . . .	15,16
Inspect connection between cable and 40-pin header (MD-11) . . . . .	17
Inspect connection between cable and Expansion Board (MD-11) . . . . .	17

THE SERVICE PROCEDURES DESCRIBED IN THIS DOCUMENT ARE TO BE PERFORMED ONLY BY AUTHORIZED MORROW DESIGNS DEALERSHIPS. ONLY QUALIFIED SERVICE PERSONNEL SHALL PERFORM THE INSTALLATION. QUALIFICATION MAY BE OBTAINED BY SATISFACTORY COMPLETION OF A MORROW DESIGNS SERVICE SEMINAR OR EQUIVALENT TRAINING AND EXPERIENCE IN PERSONAL COMPUTER SERVICE.



## APPENDIX A. INSTALLING THE COPROCESSOR BOARD

The Coprocessor Board is mounted inside the Micro Decision cabinet as if it were a half height floppy drive. The connection between the coprocessor board and the motherboard is made via a smaller board called the Expansion Board. Installing these two boards can be done in less than an hour the first time through, and is a cinch for anyone experienced in Micro Decision Service.

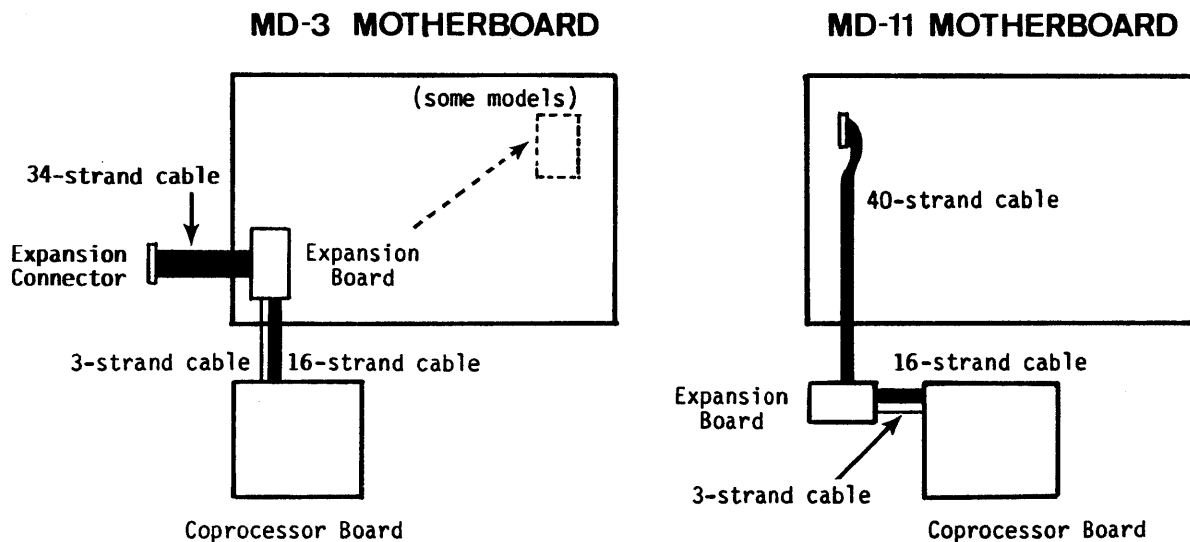

Figure A-1: Hardware Block Diagram

For those of you without much Micro Decision experience, we will do everything possible to make it easy for you to do the right things. We will also demonstrate to everyone the points where making a mistake can be fatal to the motherboard or coprocessor board.

### A.1 Qualified Installers

Qualified service personnel are Morrow dealers or their employees who have attended the Morrow Service Seminar, or have equivalent training and experience in the servicing of personal computers. This still doesn't guarantee flawless installation, but mistakes are then the dealer's responsibility, not the owner's.

## **A.2 Which Micro Decisions Can Use the Coprocessor?**

The Coprocessor board can be added to MD-3 and MD-11 Micro Decisions. Owners of MD-1's and MD-2's that wish to add the coprocessor must first upgrade their Micro Decision to the level of the MD-3 (Upgrade kit #MD2-MD3). In the case of "old" Micro Decisions that do not have the Centronics parallel port (Revision 1.1), the motherboard must be upgraded also (to Revision 2.0, with Upgrade kit #MDR1-MDR2).

## **A.3 What Tools Do You Need?**

- o phillips head screwdriver, size number 2 is perfect
- o soldering iron, 25-40 watt, (650-750 degrees F)
- o rosin core solder

## **A.4 What's in the Box**

Besides this manual, you should have also discovered an MS-DOS manual, a SuperCalc II manual, and several diskettes. The parts included are slightly different for MD-3 kits and MD-11 kits:

- o Coprocessor board and mounting bracket (about 6"x7" or 14.5 x 18 cm.);
- o Expansion board (about 1.75" x 3.25", or 4.5 x 8.5 cm.), with attached data cable;
- o Two sets of screws, nuts and lockwashers;
- o Two sets of screws and lockwashers;
- o Two hex standoffs, like bolts with long heads (MD-11 expansion kit only);
- o Flat 34 strand cable (MD-3 expansion kit only);
- o Flat 40 strand cable (MD-11 expansion kit only);
- o Power cable with three wires; and
- o 40 pin header: two rows of 20 pins in a plastic holder, or the equivalent (a 34 and a 6 pin header, for example).

## **A.5 Hardware Installation Overview**

These are the steps involved during installation of the hardware:

- Park Hard Disks!
- Disconnect all cables, power cord first
- Remove chassis cover
- Remove power supply
- Remove disk drives
- Remove motherboard
- Install 40-pin header (solder carefully)
- Replace motherboard
- Install Expansion Board (check carefully)
- Replace disk drives
- Install Coprocessor Board
- Replace power supply
- Replace chassis cover and cables

The software is already set up for your hardware (assuming you have a Morrow terminal), and will be used to test the hardware. A guide to the use of the software forms the first part of this manual.

## **A.6 Park Hard Disks!**

On MD-11's, you'll be disconnecting and removing the hard disk, so be sure to run the PARK.COM program before preparing to disassemble the Micro Decision.

## **A.7 Disconnect All Cables**

1. Unplug the Micro Decision power cord and remove it from the back of the Micro Decision.
2. Disconnect any peripheral cables that may be attached to the back of the Micro Decision.

## **A.8 Remove the Chassis Cover**

1. Turn the Micro Decision upside down. Remove the four screws shown in Figure A-2.
2. Stand the chassis up on its back panel, and slide the cover up and off.

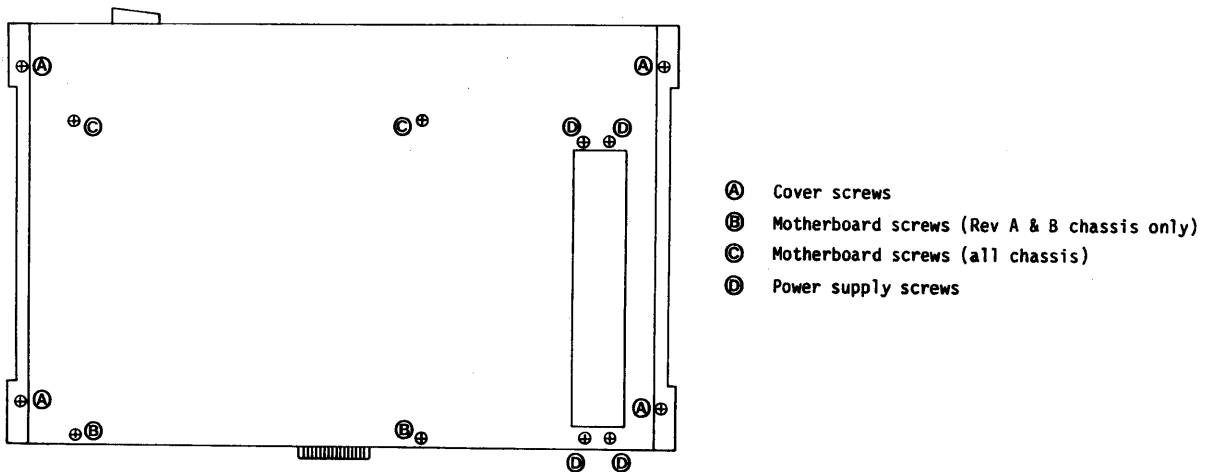

**Figure A-2: Bottom of Micro Decision Chassis**

### **A.9 Remove the Power Supply**

1. Set the Micro Decision right side up. The power supply is the ventilated box located on the right side of the chassis.
2. Disconnect the power supply cables:

MD-3's:

- o Motherboard power supply, right edge of motherboard, and
- o Pilot lamp, in the front panel reset switch.

MD-11's:

- o Two disk drive power cables from back of drives;
- o Pilot lamp, in the front panel reset switch.

On MD-11's, you can't remove the connection to the motherboard until you remove the hard disk, (and you can't remove the hard disk without removing the power supply).

3. Lay the Micro Decision upside down again. Remove the four screws, two at each end of the power supply and the power supply will fall to the table.
5. Turn the chassis right side up again and set the power supply aside.

## A.10 Remove the Disk Drives

But before you do, there is a slight chance that you can skip this step and the next (Remove The Motherboard). Some MD-3's have motherboards that were assembled in Korea. The layout of these boards is different than MD-11 motherboards, and MD-3 motherboards assembled in Japan.

Look on the MD-3 motherboard, along the right edge (power supply side) and the motherboard will be labeled either "ASSEMBLED IN KOREA" or "KOHJINSHA ... MADE IN JAPAN". If your motherboard is Korean-assembled, the 40-pin header is located just to the left of the power connector, and is labeled J5. If you have an MD-11 or Kohjinsha-made MD-3, skip the next paragraph.

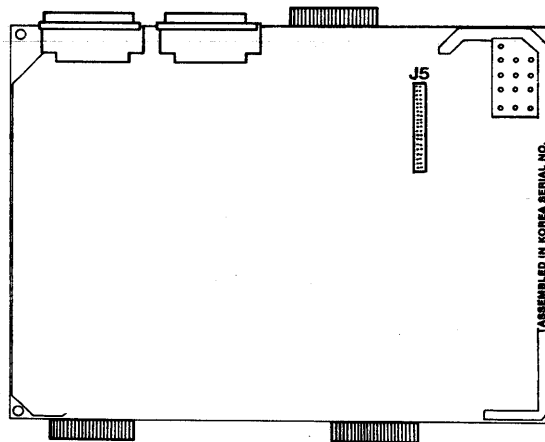

**Figure A-3: Korean Assembled Motherboard**  
(with 40-pin header already installed)

Okay, now that you have found where connector J5 should be, is there anything there? Some Korean motherboards have the 40 pin header (two rows of 20 little square pins) installed, but most do not. If you see two rows of holes, you're out of luck. If the 40-pin header is already installed, skip ahead to "Installing the Expansion Board".

### A.10.1 Remove The Disk Drive Cables

1. Remove the power cables from your disk drives (MD-3's only; you've already removed them from MD-11 drives).
2. Take a permanent marking pen or some tape that you can write on and label the top of each remaining drive connector:

MD-3's:

Label the top of the connector to the top drive "TOP", and the bottom drive's connector, "BOTTOM".

MD-11's:

Label the top of the connector to the floppy drive "FLOPPY". The hard disk has two connections. Label the wider one "CONTROL" and the narrow one "DATA". Actually, it is impossible to confuse the control and data lines because of their different sizes, but the floppy cable and the hard disk control cable are identical in size, so take heed.

3. Once you have labeled your cables you can safely remove them by sliding them toward the back of the chassis.

#### A.10.2 Drive Removal

1. Remove the two screws securing the drive(s) to the left hand mounting bracket (the side without the power supply);

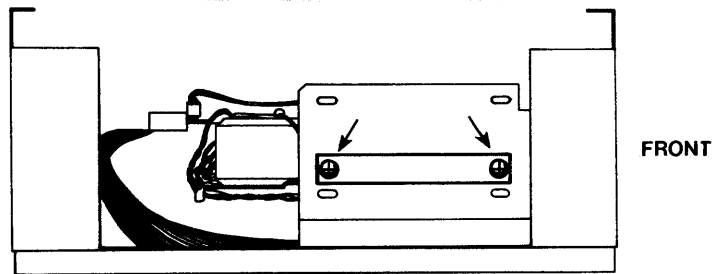

Figure A-4: Disk drive mounting bracket, left side

2. Remove the two screws that secure the "L" shaped support brackets (Figure A-5). These two screws go through the short leg of the "L" in the middle of the drive shelf.

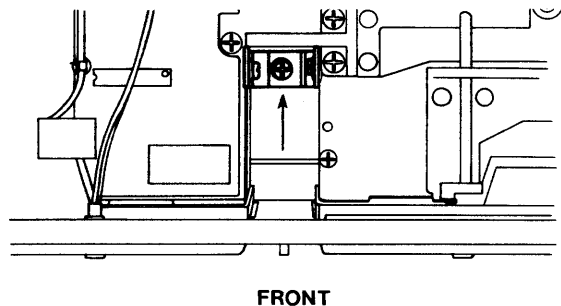

Figure A-5: L-shaped brackets securing drives

3. Slide the drive(s) back into the chassis an inch or two and lift them up and out. You do not need to separate the two drives in MD-3's from each other. Just set them safely aside.
4. If you are working on an MD-11, the hard disk may still be secured by two screws attached to the right of the drive through the right hand shelf support bracket. Remove these two screws, slide the drive an inch or two back into the chassis, lift it out and put it gently aside.

### A.11 Remove the Motherboard

In the course of Morrow's history, there have been three different Micro Decision chassis. The small differences between the chassis affect the removal of the motherboard in little ways.

But, before removing the motherboard, be sure the 40-pin header has not been installed already, as discussed above under "Remove the Drives."

The place for the 40 pin header is located along the edge of both the MD-11 and the Kohjinsha MD-3 motherboards. If you see forty holes neatly arranged in twenty pairs, continue working through this section. If you have forty little square pins in location F through K (for MD-3's, Kohjinsha), or J-5 (MD-11's), please skip this section, and the two that follow it. Pick up this narrative again at "Installing the Expansion Board".

- A. The Revision A chassis is identified by the little box set in the back panel (cord pan). Remove this box (it's held on by screws) before removing the motherboard and replace it after the motherboard is reinstalled.

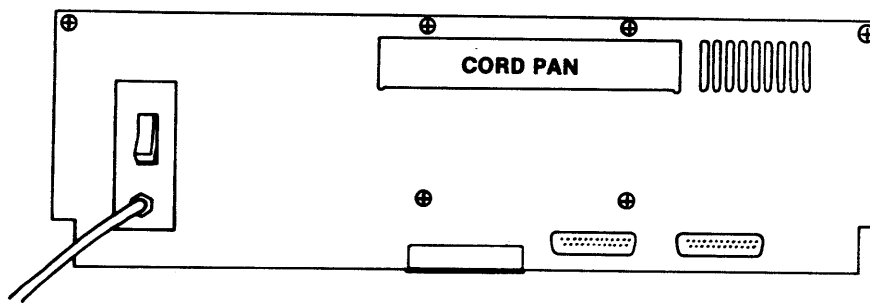

**Figure A-6: Revision A chassis back panel**

- B. The Revision B chassis is identified by a rectangular knock-out above the parallel port connector. Remove this knockout by prying out the corners that are not attached, and twisting it back and forth until the two connections get tired (fatigued) and break off.

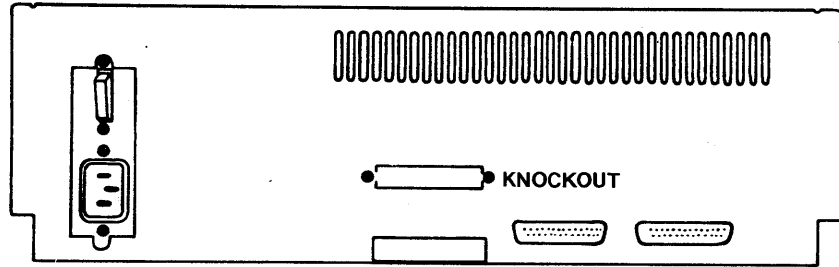

**Figure A-7: Revision B chassis back panel**

C. The Revision C chassis has two knockouts: a circular one, on the left of the back panel, for the MD-11's fan, and a rectangular one, running up and down at the right edge of the back panel.

1. Remove the rectangular knockout, as described for the Revision B chassis;
2. Remove the two motherboard backplate screws.

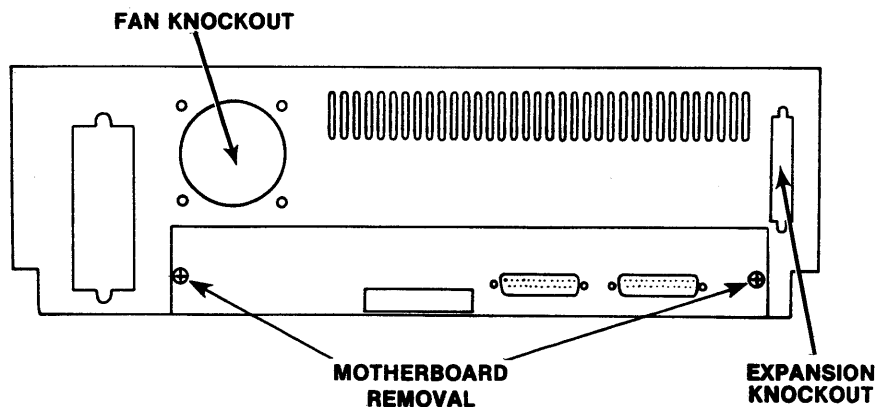

**Figure A-8: Revision C chassis back panel**

#### **A.11.1 Disconnect a Few More Wires**

There are one or two more wires to remove before pulling out the motherboard.

MD-3's:

Two wires come from the reset switch and attach to two pins in the region of the power connection, labeled either JR (Kohjinsha) or E5 (Korean). Unplug these wires from the motherboard.



MD-11's:

Two wires connect the reset switch to the motherboard at JP5 (near board center). Unplug these wires.

Two more wires attach to the motherboard from the fan (labeled J10 on motherboard). Unplug these wires.

Disconnect the motherboard power supply.

### A.11.2 Motherboard Removal

The motherboards of ALL chassis types are attached to the bottom of the chassis by four screws. Lay the chassis on its left side (end opposite the space for the power supply) and remove the four screws holding the motherboard. These screws are the only ones left, so you can't miss them. As you unscrew the last screw, hold the motherboard gently in place so that it doesn't fall ungracefully. Lay the chassis right side up again.

If any of these screws seem stripped, it is probable that the standoffs that are glued to the bottom of the motherboard have come loose. These standoffs are visible on top of the motherboard as white plastic pins, about 1/2" (2 cm) long, sticking through plated metal holes. You can try holding these pins with pliers while you unscrew the screws.

Most likely, you will wind up breaking them off. If this happens, use pliers to hold the plastic pieces while you unscrew them (after removing the motherboard), and use epoxy to reattach them to the bottom of the motherboard in the old locations. These pieces are essential: they separate the bottom of the motherboard from the metal chassis. Failure to replace these plastic pieces will likely result in a smoking Micro Decision (guaranteed fatal for the motherboard).

### C A U T I O N !

To avoid damage to the motherboard from static electricity discharge:

- o wear a grounded wriststrap, OR
- o discharge yourself frequently by touching the chassis, AND
- o spray carpets in the immediate area with a fine mist of water.

Revision A and B Chassis:

1. Slide the motherboards forward until the cable connections (RS 232 and parallel port) are clear of the back panel.
2. Tilt the board up at the back, sliding the front edge of the board out from under the disk drive shelf. Lift the board out and set it on a convenient work surface.

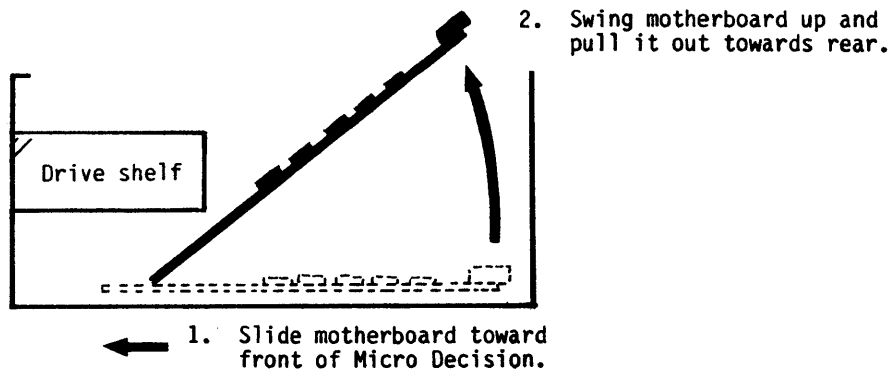

**Figure A-9: Motherboard removal, Revision A and B chassis**

Revision C Chassis:

1. Slide the motherboard out through the back panel.

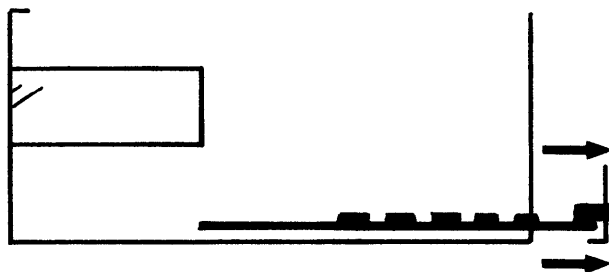

**Figure A-10: Motherboard removal, Revision C chassis**

## A.12 Install the 40 Pin Header

You are now ready to solder in place the 40 pin header (Figure A-11). You should already know where the header goes, but in case you've forgotten:

On the MD-3's assembled in Korea, the header goes in the forty holes labeled J-5, near the motherboard's power connection;

On the MD-3's assembled in Japan, the header goes in the forty holes located along the edge furthest from the power connection, locations F through K;

And, on MD-11's, the header goes in the forty holes located at the edge furthest from the power supply connection, near the terminal RS 232 connection, and is labeled J-5.

The header fits on the same side of the board as all of the other components.

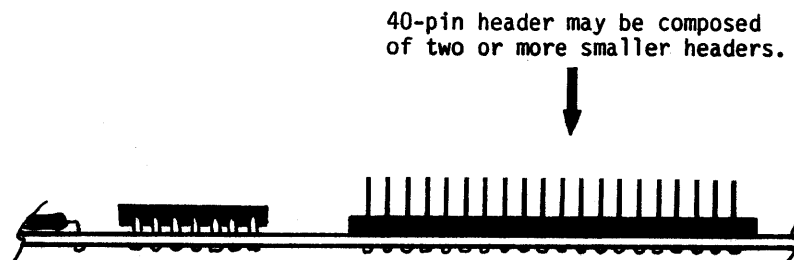

**Figure A-11: 40-pin header orientation**

1. Put the header in place with the short pins through the board. If you have several headers that collectively make up one 40 pin header, install the headers one at a time, and start with the pair of holes nearest the front edge of the motherboard.
2. Hold the header in place while you turn the board upside down. Start by soldering two opposing corners in place. Turn the motherboard back over and check that the black plastic of the header is snug against the motherboard at both ends. If not, resolder the corners while pushing the header against the motherboard until the header is properly positioned.
3. Solder the remaining pins.

### Tips on soldering

Use a temperature-controlled or other suitable (25-40 watt) pencil-type soldering iron;

Use rosin-core solder... do NOT use acid core solder;

Touch the soldering tip to one side of the pin while holding the solder on the other; wait for the solder to form a shiny bubble around the pin; if the bubble looks dull, hold the soldering tip against the pin until the bubble looks shiny;

Use only enough solder to make a small "bubble" around the pin; too much solder will "bridge" pins together.

### **C A U T I O N !**

When you have finished soldering, examining your work carefully: even experts can make mistakes. THIS IS ONE OF THE POINTS WHERE A MISTAKE WILL DESTROY THE MOTHERBOARD. Look at each of the pins and check to see that none of the pins have been connected together by excess solder (bridging). Use a magnifying glass if necessary. Also check to see that each bubble is shiny. Dull appearing bubbles indicate a cold solder joint, essentially a connection with built-in high resistance. Clean up any bridges, reheat cold soldered joints, then double-check your work. A little extra attention now will save time and money later.

4. If you have several header pieces, please finish installing them, filling all forty holes.

### **A.13 Replace Motherboard**

First, check the bottom of the motherboard to be certain that all four white plastic standoffs are securely in place. Remember, these plastic pieces insulate the motherboard from the chassis and are vitally important. If any are missing, locate them and epoxy them back in place. They should not spin in their mounting holes. If they do, you'll have a hard time tightening the motherboard's screws.

**Revision A and B chassis:** slide the front edge of the motherboard (the side without the RS 232 connectors) in under the disk drive shelf. When the motherboard is resting against the bottom of the chassis, slide the motherboard toward the back so that the RS 232 connectors protrude through the back panel.

**Revision C chassis:** If you have a chassis with the removable lower back panel, slide the motherboard back into the chassis.

1. Set the chassis up on its left side again, while gently holding the motherboard in place. Replace the four screws (with lockwashers) that hold the motherboard to the chassis bottom. These screws can be identified by the small cuts at their tips (self-tapping screws). On chassis with removable back panels, replace the two screws and lockwashers (also self-tapping) that hold the panel in place.
2. Replace the two wires that come from the reset switch. These yellow and black wires end in a connector that attaches to: E5 on the Korean MD-3, JR on the Kohjinsha MD-3 and J5 on the MD-11.
3. The two fan wires must also be attached to the MD-11 board at J-10. There are three pins, and a three hole connector, but only TWO wires. The two wires are connected to the BACK two pins (this controls fan direction, blowing air into the chassis).

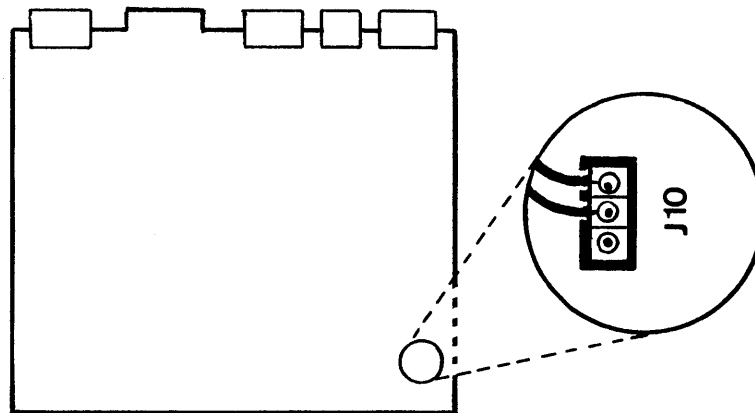

**Figure A-12: MD-11 fan wire connection to motherboard**

## A.14 Installing the Expansion Board

The installation of the expansion board is another critical point. If you install the board so that two pins are missed (and this is easy to do), the motherboard will be destroyed when you turn the power on. Fortunately, it is very easy to check for this, and we'll remind you when the time comes.

Before installing the expansion board, you must add the power cord (three wires with connectors at both ends) and the data cable (the 16-strand flat ribbon cable with chip-like connectors at both ends) to the expansion board.

1. Attach the three-hole connector at one end of the power cord (A of Figure A-13) to the three prongs on the expansion board.

### C A U T I O N

Be certain that the connector is attached to ALL three prongs. If you miss one, you will reverse the power to the coprocessor board, destroying it.

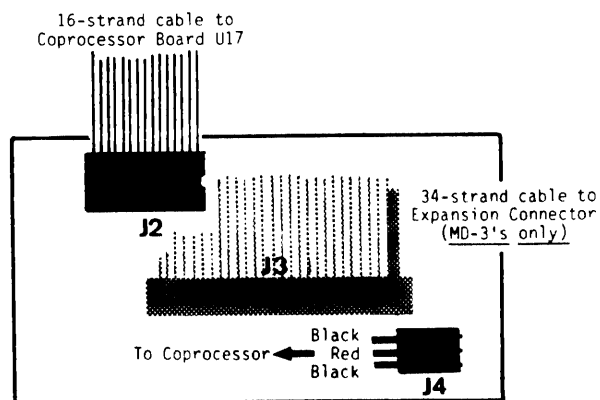

Figure A-13: Expansion Board and cables

2. Attach the data cable (B of Figure A-13) to the empty chip socket (C) so that the cable extends over the nearest edge of the board without being folded. On some expansion boards, this cable will already be soldered in place. On earlier boards, the chip socket may be missing. In this case, solder the data cable into the 16 holes.
3. Hold the board up to eye level so that you can be certain that all data cable pins are in the socket. Missing a pair of pins won't destroy anything; but the coprocessor won't work.

4. For MD-3 installations, attach the 34 strand flat cable to the expansion board so that the cable extends over the data cable without being folded. The stripes on the cables corresponds to pin 1 of the sockets. **Having the stripe correspond to pin 1 is a Morrow convention that is followed throughout Micro Decision assembly.**

### A.15 Connecting the Expansion Board to the 40 Pin Header

Each style of motherboard requires a slightly different installation procedure, so select one section of the three that follow. For MD-3's, there is an additional section for both chassis types, ("MD-3's Again").

#### A.15.1 MD-3 Motherboard by Kohjinsha

This is the motherboard assembled in Japan. The 40-pin header is at the left edge of the motherboard.

1. Hold the expansion board so that the power cable extends toward the rear of the chassis and the data and 34-strand cables toward the right.
2. Line the connector on the bottom of the expansion board up with the 40-pin header by peeking in through the side of the chassis so you can see under the expansion board.
3. Press the connector into place.

### C A U T I O N

Look carefully at the connector by looking between the motherboard and the Expansion Board. If you can see any of the header pins, you have misconnected the Expansion Board and will DESTROY THE MOTHERBOARD. Remove the Expansion Board and try again.

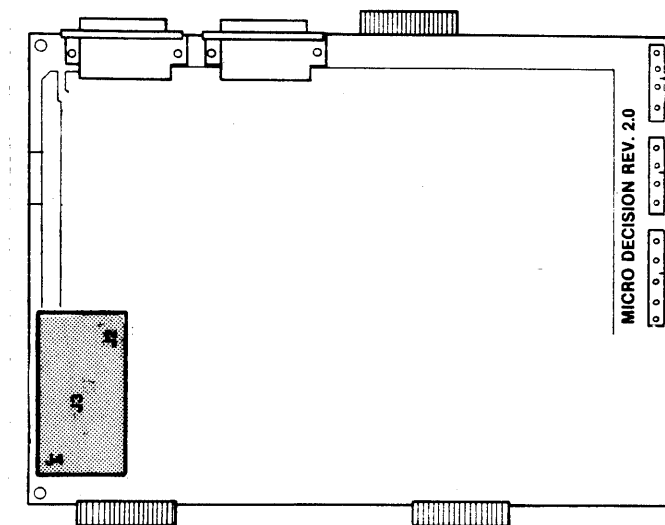

Figure A-14: Installation of Expansion Board: Kohjinsha MD-3

### A.15.2 MD-3 Motherboard "Made in Korea"

The Korean-assembled motherboard has the 40-pin header located near the power supply connection, and labeled J5.

1. Hold the expansion board with the power cord pointing toward the rear of the Micro Decision and the data and expansion cables to the right.
2. Line the connector on the bottom of the expansion board up with the 40 pins on the motherboard carefully.
3. Press the connector on the bottom of the expansion board over ALL 40 pins.

#### C A U T I O N

Look carefully at the connector by looking between the motherboard and the Expansion Board. If you can see any of the header pins, you have misconnected the Expansion Board and will DESTROY THE MOTHERBOARD. Remove the Expansion Board and try again.

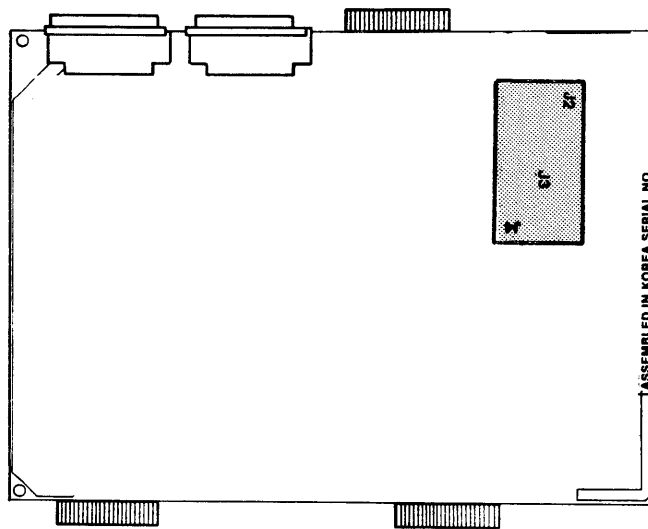

Figure A-15: Connection of Expansion Board: Korean MD-3

### A.15.3 MD-11

The expansion board is NOT connected directly to the MD-11 motherboard. Instead, a pre-folded 40-strand cable is carefully attached to the 40-pin header that is on the left edge of the motherboard.

1. Attach the female end of the cable to the header so that the cable extends first to the right, then takes a turn toward the rear.



## CAUTION

Carefully examine the connection between the cable and the 40-pin header. If any pins are visible, you have misconnected the cable and will destroy the motherboard. Remove the cable and try again.

2. Look at the Expansion Board. There are two holes located at either end of a 34-pin connector. Take the hex standoffs and attach them to the top (side with chips) of the Expansion Board. Use the nuts and lockwashers provided, but don't tighten the nuts yet.

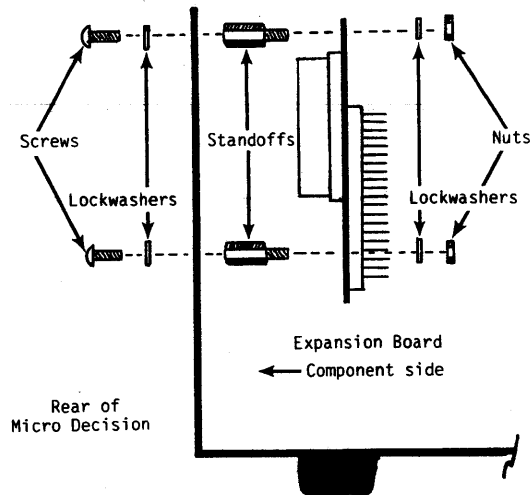

**Figure A-16: Assembly of Expansion Board, MD-11**

3. Line the Expansion Board up with the slot (our rectangular knockout) in the back left-hand corner of the chassis (all MD-11's have Revision C chassis). Using the two screws and lockwashers, fasten the expansion board to the inside of the back panel. The 34 pin connector on the expansion board should fit out the slot (it may be a tight fit, but it will work). Once the 34 pin socket has been fitted into the slot, tighten the two screws, then the nuts on the standoffs.
4. Plug the male end of the cable onto the rear of the expansion board. The red stripe will be on top.

## CAUTION

Carefully examine the connection of the cable to the Expansion Board. The cable connector must be centered on the Expansion Board socket. If you miss any pins, the motherboard will be destroyed.

#### **A.15.4 MD-3's Again**

The 34-strand flat cable attached to the top of your expansion board is for connecting the expansion board to the back panel. The Morrow Network, for example, would be connected to this cable through the knockout.

1. Fold the cable so that it heads toward the knockout in your back panel. If you have a Revision A chassis, route the cable out the cord pan opening and ignore the rest of these instructions.
2. Revision B Chassis (Center knockout): Orient the free end of the cable so that the stripe, that is, pin 1, is on the left when looked at from the front of the chassis. Use the two screws, lockwashers and nuts to fasten the connector in the knockout opening. The nuts should be inside the chassis.

Revision C chassis, (knockout on the left when viewed from the front): Arrange the connector in the knockout opening so that the stripe, pin 1, is up. Fasten the connector in place with the two screws, lockwashers and nuts. The nuts should be inside the chassis. Fold the excess cable so that it stays neatly in the corner.

There are now several layers of flat cable heading away from the expansion board. In the case of Kohjinsha motherboards, there are three cables: the floppy drive cable, the data cable and the 34-strand cable to the back panel. Arrange these cables so that they lie as flat as possible because a moving part of the floppy drive (the motor) will be installed immediately above these cables. If the cables rub against the motor, you will be able to hear it, and the Micro Decision may fail to boot.

#### **A.16 Replace Disk Drives**

The disk drives are replaced in the same order that they were removed.

##### MD-11 only:

1. If you have a full-height hard disk (half-height hard disks are mounted together with half-height floppies), first attach the power supply to the motherboard. Then, set the drive inside the chassis, on the disk shelf on the right side, and slide it forward into the front panel. The disk's circuit board will be on the bottom.
2. Attach the drive with two screws and lockwashers to the right hand shelf bracket, but don't tighten the screws yet.

### MD-3 and MD-11:

3. Set the floppy drive(s) on the inside of the chassis on the disk shelf and slide the drive(s) forward into the front panel. The floppy drive circuit boards will be on top. Make certain that the ends of the power and data cables from the expansion board are not covered. Attach the drives to the left shelf bracket with two screws and lockwashers, but don't tighten them yet.
4. Line up the "L" brackets with the holes in the disk shelf and install the last two screws and lockwashers. Tighten all the screws holding the drives.
5. Reconnect the various disk cables. On MD-3's, also connect the disk drive power cables to the drives. The white connectors for these cables only fit one way.

If you didn't label the cables, the left hand cable goes to the bottom drive on MD-3's. **The stripe on all disk drive cables lines up with the slit cut in the edge connector of the drive's circuit board.** The disk cables of MD-11's are connected to the motherboard with: the floppy cable nearest the left edge, the hard disk control cable next, and the hard disk data cable (the small one) last.

### **A.17 Installing the Coprocessor Board**

The Coprocessor Board comes attached to a "U" shaped bracket that is designed to attach to a disk shelf bracket.

#### 1. MD-11's:

Install the board above the floppy drive. Fasten the bracket to the inside of the left shelf bracket with two screws and lockwashers. The PC board must be on top.

#### MD-3's:

Fasten the coprocessor bracket inside the empty right hand shelf bracket, also with two screws and lockwashers, so that the circuit board is on top.

2. Plug the data cable, (both MD-3' and 11's), into the empty chip socket so that the cable hangs out over the edge of the circuit board without being folded. Check to see that you've attached all of the pins. A mistake here will not destroy anything, but the coprocessor won't work either.

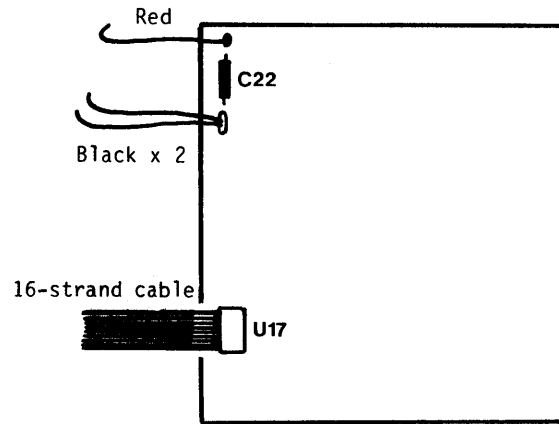

**Figure A-17: Installation of cables, Coprocessor Board**

3. Connect the power cable to two metal tabs located on the same edge of the Coprocessor Board as the data cable. The connectors are two different sizes to eliminate mistakes. The red wire has the smaller connector and slides onto the tab labeled "+". The two black wires have a larger connector, and slide onto the larger tab.

#### **A.18 Replace Power Supply**

1. Set the chassis up on its right side, hold the power supply in place (the switch goes out the back panel, screw holes on the bottom) and fasten it in place with the four screws and lockwashers.
2. Connect the two little wires to the two prongs above the reset switch.
3. Connect the power to the motherboard with a group of four wires. The connector on the end of the wires is designed so that it can only be installed the right way, but make sure that you don't miss any pins anyway.
4. **MD-11 only** - Connect the two groups of four wires with solid white plastic connectors to the disk drives' circuit boards. The matching connectors are molded such that you can only plug them in the right way.

#### **A.19 Replace the Cover and Cables**

Stand the Micro Decision up on its back panel and slide the cover in place. You may fasten the cover with the screws now, if you're feeling confident, or wait until you've checked things out.

## A.20 Check-out Time

Hook up a terminal, plug in the Micro Decision and turn it on. Any smoke? Shouldn't be, since you've been careful.

### Checkpoints:

1. If the usual ROM message doesn't appear on the terminal (which is turned on, warmed up and properly connected), you have made one of those terrible mistakes we've been so worried about. There is a slight chance that you haven't destroyed the motherboard, so go back and correct your mistake (connection to the 40 pin expansion header) and try again before replacing the motherboard.
2. If the usual ROM message appears, but the Micro Decision fails to boot, check and see if you're using the correct diskette. If you are, listen for any unusual noises, like those cables we warned you about rubbing against the drive motor. When you hear the noise, you know that you need to remove the floppy drives and flatten out those cables.

Everything works like it should? Great! You're ready to try out the coprocessor board, so go to the software guide. Also, fasten the cover in place if you haven't already done so.