

TECHNICAL SERVICE MANUAL FOR



PHASE ENCODED STREAMING TAPE TRANSPORTS

Qualstar Corporation
9621 Irondale Avenue
Chatsworth, CA 91311

Easylink: 6289-9796
Telex: 510-600-2569
Fax: 818-882-4081
Phone: 818-882-5822

*Copyright © 1990 By Qualstar Corporation
Qualstar® is a registered trademark of Qualstar Corporation
Cipher® is a registered trademark of Cipher Corporation*

DOCUMENT CHANGE HISTORY

REVISION	DESCRIPTION	DATE	BY	AP-PROVED
A	Initial release.	7/31/89	JS	WG
B	Corrections and additions; reformat; update FRU list; ECN 051, 067; change warranty statement.	5/14/90	CY	

Table of Contents

1. GENERAL DESCRIPTION	1-1
1.1. APPLICABILITY.....	1-2
1.2. RELATED DOCUMENTS.....	1-3
1.3. MAINTENANCE PHILOSOPHY	1-3
1.4. FUNCTIONAL DESCRIPTION	1-3
1.5. EQUIPMENT REQUIRED FOR SERVICE	1-4
2. OPERATING INSTRUCTIONS.....	2-1
2.1. CONTROLS & INDICATORS	2-1
2.2. TAPE OPERATION.....	2-2
2.3. PRIMARY POWER CONNECTIONS	2-4
2.4. ERROR INDICATIONS.....	2-5
2.5. FIELD SELECTABLE OPTIONS	2-5
3. INTERFACE SIGNALS	3-1
3.1. OVERVIEW.....	3-1
3.2. CONNECTIONS.....	3-1
3.3. LOGIC LEVELS & ELECTRICAL SPECIFICATIONS.....	3-4
3.4. SIGNAL NAME MNEMONICS.....	3-4
3.5. DETAILED INTERFACE DESCRIPTION	3-4
3.6. DIRECT ACTION LINES.....	3-6
3.7. COMMAND INITIATION.....	3-7
3.8. COMMAND BUS SIGNAL LINES	3-9
3.9. WRITE DATA LINES.....	3-10
3.10. TAPE DRIVE TO HOST INTERFACE SIGNALS.....	3-12
3.11. SPECIAL STATUS LINES.....	3-13
3.12. REGULAR STATUS AND CONFIGURATION LINES.....	3-14
3.13. WRITE STROBE LINE (IWSTR)	3-18
3.14. READ DATA LINES	3-20
3.15. READ STROBE LINE (IRSTR)	3-20
3.16. COMMAND DESCRIPTIONS.....	3-20
3.17. OPERATIONAL CONSIDERATIONS.....	3-24
4. THEORY OF OPERATION	4-1
4.1. POWER PCBA (Schematic 500088)	4-1
4.2. READ FORMATTER PCBA (Schematic 500048)	4-4
4.3. WRITE CONTROLLER PCBA (Schematic 500058)	4-7
5. MAINTENANCE.....	5-1
5.1. ROUTINE PREVENTATIVE MAINTENANCE	5-1
5.2. TROUBLESHOOTING AND FAULT ISOLATION	5-1
5.3. GENERAL ADJUSTMENTS.....	5-7
6. FRU REPLACEMENT INSTRUCTIONS	6-1
6.1. OPENING AND CLOSING THE DRIVE	6-1
6.2. READ/FORMATTER PCBA REPLACEMENT	6-1
6.3. WRITE/CONTROLLER PCBA REPLACEMENT	6-4
6.4. POWER SUPPLY PCBA REPLACEMENT	6-5
6.5. SWITCH PCBA REPLACEMENT.....	6-6
6.6. EOT/BOT SENSOR ASSEMBLY REPLACEMENT	6-7

6.7. TACHOMETER SENSOR REPLACEMENT	6-7
6.8. REEL MOTOR REPLACEMENT	6-9
6.9. HALL SWITCH PCBA REPLACEMENT	6-9
6.10. HEAD REPLACEMENT	6-10
6.11. TAPE GUIDES.....	6-13
7. DIAGNOSTICS	7-1
7.1. EOT/BOT SENSOR CHECK FUNCTION	7-1
7.2. TAPE MOTION EXERCISE FUNCTION	7-1
7.3. BUILT-IN SERVICE DIAGNOSTIC AIDS.....	7-2
7.4. DIAGNOSTIC TESTS.....	7-3
7.5. ERROR INDICATIONS.....	7-5
APPENDIX A: GLOSSARY OF TERMS	A-1
APPENDIX B: FRU SPARE PARTS LIST	A-5

1. GENERAL DESCRIPTION

This manual describes the operating instructions, theory of operation, maintenance, replacement of the major circuit boards, field adjustments, error conditions and diagnostics for the Qualstar Phase Encoded Tape Drives. The basic tape drive in each of the models is functionally identical. This manual provides maintenance and service instructions for the basic tape drive. Included in the appendices is a glossary of tape drive terminology to assist persons unfamiliar with the essential principals of tape drives.

Before beginning any procedures, please note the setting of the DIP switches on the Write/Controller PCBA so it will be easy to restore them to their original settings.

Before servicing the tape drive, read the User's Manual and know how to an oscilloscope and voltmeter. All of the operating instructions and maintenance procedures must be followed to prevent personal injury or damage to the equipment. For safety reasons, please be aware of the three kinds of warnings found in this document:

DANGER

PERSONAL INJURY MAY RESULT IF THE HANDLING, OPERATING OR SERVICE INSTRUCTIONS FOUND IN A DANGER BOX ARE NOT FULLY OBSERVED.

CAUTION

EQUIPMENT DAMAGE OR DATA LOSS MAY RESULT IF THE HANDLING, OPERATING OR SERVICE INSTRUCTIONS FOUND IN A CAUTION BOX ARE NOT FULLY OBSERVED.

NOTE

SPECIAL ATTENTION to explanatory statements found in the NOTE box will help prevent mistakes.

1.1. APPLICABILITY

This document is applicable to the following phase encoded (PE) tape transport models:

- 1052
- 1052/1600
- 1053
- 1053B
- 1053R
- 1054

These models feature a built-in phase encoded formatter. Only the phase encoded recording (PE) format is supported by these models.

1.1.1. Model 1052

Model 1052 tape transport reads and writes magnetic tape at 1600 Bpi (bytes per inch) and 3200 Bpi.

1.1.2. Model 1052/1600

Model 1052/1600 is identical to the 1052, except that 3200 Bpi operation is not provided.

1.1.3. Model 1053

Model 1053 tape transport reads and writes magnetic tape at 1600 Bpi and 3200 Bpi and has additional room for add-in cards. Special purpose interface PCBAs are available for this model.

1.1.4. Model 1053B

Model 1053B is identical to the 1053, except that it includes a 256 KB (Kilobyte) data buffer used with systems that require emulation of start/stop operation to improve performance.

1.1.5. Model 1053R

Model 1053R tape transport reads and writes magnetic tape at 1600 Bpi and 3200 Bpi. This unit is identical to the 1053, but equipped with mounting brackets adapted for use in a E.I.A. standard 19" rack.

1.1.6. Model 1054

Model 1054 is identical to the 1053, except that it includes a SCSI (Small Computer Systems Interface) used on many popular computers.

The basic tape transports in each of the above models are functionally identical. This manual is directed at providing maintenance and service instructions for this basic tape transport mechanism.

Special interfaces such as the buffered interface PCBA and the SCSI interface PCBA are not addressed in this manual. See related documents for subjects not included in this service manual.

1.2. RELATED DOCUMENTS

- 500098 = Model 1052 Product Specification
- 500100 = User's Manual
- 500131 = Model 1054 Product Specification
- 500200 = Buffered Interface Supplement
- 500243 = SCSI Interface Supplement

1.3. MAINTENANCE PHILOSOPHY

This service manual has been written such that inoperative tape transports can be repaired and returned to service by replacement of FRU's (Field Replaceable Units). The recommended FRU spare parts list is found in the Appendix.

Replacement of parts below the FRU level are generally beyond the intent of this manual. References to sub-FRU components in the theory of operations are included for information only.

Every attempt has been made by Qualstar to assure the accuracy of this technical manual. However, Qualstar is not responsible for errors or omissions in this document.

1.4. FUNCTIONAL DESCRIPTION

The Qualstar nine-track streaming tape drive reads and writes half inch tapes in the PE format at 1600 or 3200 Bpi. The drive contains an embedded formatter which is compatible with the industry standard tape formatter interface.

The tape drive will handle 6 through 10.5 inch diameter tape reels with tape lengths up to 3600 feet. It is completely self-contained and operates from 100, 120, 220 or 240 Volts, 50/60 Hz power lines.

The Qualstar tape drive can be interfaced most microcomputers or minicomputers via a host of standard interface adapters (couplers) currently on the market.

The Qualstar tape drive is one of the smallest and lightest nine-track drives available. It was intended primarily to be used in a desk-top environment, though it can be installed into a 19 inch rack.

Three push-button switches provide the operator with the ability to load and unload tapes, to protect the tape from accidental erasure of data (File Protection) and to select the data density of 1600 Bpi(default) or 3200 Bpi.

The drive electronics are accessible for service or modification by swinging out the hinged bottom chassis.

The particular performance specifications for each tape drive model can be found in the User's Manual shipped with each unit.

1.5. EQUIPMENT REQUIRED FOR SERVICE

In order to maintain and periodically service the tape drive, some or all of the following equipment is required:

1.5.1. Test Equipment

- Dual channel Oscilloscope (100MHz or better)
- Working Tape (will be overwritten)
- Digital D.C. Voltmeter (VOM) 3 1/2 digits or better

1.5.2. Tools

- Phillips screwdriver, Number 1
- Phillips screwdriver, Number 2
- Small blade screwdriver for adjusting Trimpots
- 3/32 inch hex ball driver
- 9/64 inch hex driver
- 1600 Bpi Skew tape
- Skew adjustment wire harness (PN 500260-01-3)
- Starrett Dial Indicator No.665JZ
- Mitutoyo Carbide Dial Indicator Tip No.131259

2. OPERATING INSTRUCTIONS

2.1. CONTROLS & INDICATORS

2.1.1. POWER Switch

The POWER switch is located on the rear of the drive next to the fuse holder. Depress the upper side of the switch to apply power. Listen for the fan. If the fan does not operate, all three LED indicators will flash and the drive will be rendered inoperable. Try turning the power off and back on again. If this fails, the drive will require servicing. After a normal power up sequence, the FPT indicator should be illuminated.

CAUTION

IT IS POSSIBLE TO CREATE AN UNDESIRED FLUX TRANSITION ON A TAPE IF THE TAPE IS IN CONTACT WITH THE HEAD WHEN POWER IS APPLIED. THIS DOES NOT HAPPEN WHEN POWER IS LOST OR TURNED OFF. THIS IS NOT NORMALLY A PROBLEM, SINCE THE TAPE IS NOT USUALLY LOADED WHEN POWER IS APPLIED. IF TAPE IS THREADED PAST THE BOT TAB, BE SURE THERE IS AT LEAST 1/8 INCH GAP BETWEEN THE TAPE AND HEAD BEFORE APPLYING POWER.

2.1.2. LOAD Switch and Indicator

The LOAD switch is used to load, rewind and unload tapes. The LOAD indicator is illuminated when the tape is at the load point (beginning of tape). When tape is unloaded (no tension), the LOAD indicator will flash rapidly when a BOT reflector is sensed, thus providing a means of testing the BOT sensing circuits.

2.1.3. FPT Switch and Indicator

FPT is an abbreviation for File Protect. This switch provides a means of preventing accidental writing on or erasure of a tape. The drive will not allow writing or erasing when the FPT indicator is illuminated.

CAUTION

In many tape transports, a write enable ring on the tape reel is used to protect files. THE PRESENCE OR ABSENCE OF THIS RING IS IGNORED BY THE QUALSTAR TAPE DRIVE.

The drive automatically sets the file protected state when a tape is first loaded. The user may change the FPT state only when the tape is loaded and at the load point (LOAD indicator illuminated) by pressing the FPT switch. The FPT indicator serves as a power indicator when tape is not loaded.

2.1.4. 3200 Switch and Indicator

The data density for both writing and reading is indicated by the 3200 indicator. When illuminated, the 3200 Bpi density has been selected. If extinguished, 1600 Bpi is indicated. This 3200 Bpi function has been disabled on 1600 Bpi only models. The density may be selected by the user only when the tape is loaded and at the load point by pressing the 3200 switch. The controller may also select either density when a tape is loaded and at the load point. When tape is unloaded (no tension), the 3200 indicator will flash rapidly when an EOT reflector is sensed, thus providing a means of testing the EOT sensing circuits.

2.2. TAPE OPERATION

2.2.1. Load Tape

To load a tape, depress the inside of the three reel clamps on the supply reel hub. Place the tape reel over the hub (label side out). Depress the outside of all three reel clamps to lock the reel to the hub.

Thread the tape as indicated by the raised ridges on the surface of the casting. Wrap the end of the tape around the take up hub such that a clockwise rotation winds the tape onto the hub. Rotate the hub clockwise until at least three layers of tape are on the take up hub. Hold the supply reel and further rotate the take up hub until all slack is removed.

With power applied, press the LOAD switch to initiate the load sequence. There will be a slight pause before the tape begins moving forward. It will then run forward past the BOT reflective marker, whereupon it will reverse and run until the BOT marker is ahead of the head. The LOAD indicator will then illuminate indicating the tape is at BOT.

Should the tape fail to load properly because of an operator error, the drive will normally terminate the load sequence and display a load fault by flashing the LOAD indicator. Reload the tape properly and press the LOAD switch for 1 second to resume the load sequence.

Once the tape has stopped at BOT and the LOAD indicator is illuminated, the drive automatically sends ONLINE and READY to the host, indicating that the unit is ready to operate.

It is sometimes necessary to re-load a tape near the end of a reel (after a power interruption or running off the end of tape). Prior to loading, make certain the EOT tab is on the supply reel and that all slack is removed. Hold the FPT switch before pressing the LOAD switch. This will change the load operation to compensate for the large amount of tape on the take up reel.

2.2.2. File Protection

To enable recording, press the FPT switch (File Protect) to extinguish the FPT indicator. The FPT status may only be changed when the tape is at the load point. Repeated operation of the FPT switch will toggle the FPT status.

2.2.3. Data Densities

To read pre-recorded tape, the density of the tape must match the density set on the drive. If uncertain of the tape density, start with 1600 Bpi.

When recording a new tape or rewriting a pre-recorded tape, the recording density may be selected at the drive. If the tape is to be used for interchange purposes, use the 1600 Bpi density unless it is certain that the receiving facility has 3200 Bpi capability.

Before appending data to a tape which presently contains data, select the same density at which the tape was originally written. The most common data density is 1600 Bpi.

2.2.4. Unloading Tape

If the tape is not at BOT, press the LOAD switch to rewind it. When the tape reaches BOT, press the LOAD switch again to initiate an unload sequence. The tape will unwind until it leaves the take up hub, whereupon it will automatically stop.

2.2.5. Aborting Runaways (Offline)

Occasionally it may be necessary to abort a tape operation. This is preferably done at the host via methods specified by the user's application program. If the application program is unable to abort a read or write once in progress, then an offline operation is required. The tape drive may be forced offline by depressing the 3200 switch until the tape comes to a complete stop. This should cause the application program to terminate.

If the 3200 switch is not held down until tape motion completely stops, the drive will reposition and resume executing the next command supplied by the application program.

If the application program fails to terminate by depressing the 3200 switch, the operator may abort by depressing both the FPT and 3200 switches until the tape comes to a complete stop. The drive will then go offline for 5 seconds. This procedure will truncate the writing of any data block, possibly causing loss of data.

2.2.6. Cleaning the Head and Tape Path

The head and tape path components should be cleaned regularly to maintain maximum data reliability. To clean the head, use a lint free cloth or cotton swab moistened in 91% isopropyl alcohol. Wipe the head carefully to remove all accumulated oxide and dirt. Do not use rough or abrasive cloths to clean the head. Only isopropyl alcohol or an approved head cleaning solution should be used. Other solvents may damage the head lamination adhesive.

The tape guides, tape rollers and tape cleaner should also be cleaned with a cloth or swab moistened with the head cleaning solution. Do not spill any solution which could seep into the tape guide bearings, as it may damage their lubricant.

2.3. PRIMARY POWER CONNECTIONS

DANGER

DANGEROUS VOLTAGES ARE PRESENT IN THE POWER SUPPLY. DISCONNECT THE PRIMARY AC LINE CORD BEFORE REMOVING THE TERMINAL BLOCK COVER.

The primary connections to the power supply are shown in the table below. Nominal line voltages of 100V, 120V, 220V, and 240V at 50 or 60 Hz can be used as primary input power. Units will normally be wired at the factory for either the low series (100-120) or the high series (220-240). Units can be converted in the field only within a given series by changing the transformer connections at a terminal block located within the power supply chassis.

2.3.1. Voltage Jumpers

VOLTS	JUMPERS	POWER	BODY	FUSE RATING
100	1-4,3-5	2 and 5	3AG	2.0A Slow Blow ⁽¹⁾
120	1-4,3-5	1 and 5	3AG	2.0A Slow Blow ⁽¹⁾
220	3-4	2 and 5	5X20 MM	1.0A Slow Blow ⁽²⁾
240	3-4	1 and 5	5X20 MM	1.0A Slow Blow ⁽²⁾

¹ Model 1053B requires a 2.5 A slow blow, Qualstar p/n 626-0007-7.
² Model 1053B requires a 1.25A slow blow, Qualstar p/n 626-0008-5.

Table 2-1. Voltage Jumpers

2.3.2. Fuse Information

RATING	QUALSTAR P/N	LITTLEFUSE P/N	BUSSMAN P/N
2.0 Amp	626-0003-6	313002	MDL 2
1.0 Amp	626-0004-4	218001	GDC 1.0

Table 2-2. Fuse Ratings

2.4. ERROR INDICATIONS

Errors can be caused by operator error, controller error, or by drive faults. The Qualstar tape drive detects these error conditions and disables further operation until they are corrected (if possible) or acknowledged by the operator. All error conditions are indicated by a combination of one or more flashing indicators.

The following table summarizes the error conditions. Following the table, each error condition and possible remedies are described in detail.

LOAD	FPT	3200	FAULT/ERROR CONDITION
ON	off	off	Load Error
off	ON	off	File Protect Error
off	off	ON	Read after Write Fault
ON	ON	off	Start/Position Fault
ON	off	ON	Write/Erase Power Fault
off	ON	ON	Write/Erase Power Fail
ON*	ON*	off	Motion Fault
ON	ON	ON	Fan Failure Fault

* indicates alternately flashing

Table 2-3. Error Indications

For further discussion of errors, refer to the section entitled Diagnostics.

2.5. FIELD SELECTABLE OPTIONS

Several operating options may be selected in the field. These are effected by changing push-on jumpers or DIP switches on the Write/Controller PCBA which is located on the hinged chassis of the drive.

To open the drive, turn the power off and stand the drive up vertically (switches up). Remove the five number 8 Phillips screws around the periphery of the chassis bottom and swing the chassis open. The Write/Controller PCBA will be on the right (the top PCBA on the power supply chassis).

An 8 position DIP switch is located in the upper right corner of the PCBA. The switches are numbered S1 through S8. The switch is on when the slider is up.

CAUTION

SWITCHES 5 THROUGH 8 CONTROL THE OPERATION OF THE REEL MOTORS. THEY ARE SET AT THE FACTORY AND SHOULD NEVER BE CHANGED IN THE FIELD.

There are two groups of jumpers: W1-W8 at the bottom of the PCBA and W9-W16 in the middle of the PCBA. A jumper is considered installed when a shorting bar is installed at the specified location.

2.5.1. Read While Write Threshold (S2)

This switch has no effect on current production models.

2.5.2. Write Inter Block Gap Extension (S3 & S4)

The nominal interblock gap (IBG) is 0.6 inches. This distance can be extended during writing to allow the host more time to fetch the next block. Doing so reduces the amount of data which will fit on a tape but keeps the tape streaming, greatly increasing system throughput.

If the IBG is extended and the host does not issue another write command within the specified distance (see Specifications for corresponding times), the drive will stop and reposition the tape. The next IBG will then be the nominal 0.6 inches. If the host issues the write command in less than the maximum selected distance, the drive will immediately start writing and the write IBG will be less than the maximum selected.

Four write IBG lengths can be selected by switches S3 and S4:

S3	S4	IBG LENGTH
off	off	0.6 inch max.
off	ON	1.8 inches max.
ON	off	5.4 inches max.
ON	ON	16.2 inches max.

The drive is shipped with the 0.6 inch setting. These switch settings do not affect the maximum read IBG of 25 feet. Exercise caution when extending the write IBG as it can affect the maximum amount of data that will fit onto a tape. Generally speaking, use the smallest setting which keeps the tape streaming during writing.

2.5.3. Internal/external Parity Generation

The nine-track tape format specifies 8 data tracks (supplied by the host) and a parity track. The parity data can be either generated by the drive (default setting) or sent by the host.

The advantage of generating the parity data externally (at the host) is that any errors which occur in the Write Data line drivers, cables or line receivers will be detected during writing. With internal parity generation, the parity will be correct regardless of the incoming data. Internal parity generation is provided because many host coupler PCBAs cannot generate write parity.

To select external parity generation, move the jumper from W2 to W3. To select internal parity generation, move the jumper from W3 to W2.

2.5.4. Formatter Address

The drive's formatter can respond to any one of eight addresses (0 through 7). As shipped, the drive responds to address 0. To change the address, move the jumper from W9 to W10 through W16. The drive address is equal to the W number minus 9. Only one jumper is allowed on W9 to W16.

2.5.5. Control Of Status Signals

Three of the drive status signals can be enabled by two possible conditions. These signals are:

- IRWD (drive is rewinding)
- IFPT (drive is File Protected)
- IONL (drive is online)

The signals are normally (as shipped) enabled when the drive is selected, the tape is loaded, and the tape is not rewinding. They may be enabled whenever the drive is selected, regardless of the loaded or rewinding states by moving the jumper from W6 to W5.

3. INTERFACE SIGNALS

3.1. OVERVIEW

This section describes the details of a device level formatted phase encoded tape drive interface which is compatible with the industry de facto standard. Each tape drive contains a built-in formatter which performs the format related tasks required to write and read IBM/ANSI phase encoded (PE) 9 track tape.

3.2. CONNECTIONS

The formatter interface uses two 50-pin printed circuit edge connectors referred to as J1 and J2. The interface connections at J1 and J2 require a 3M brand connector, part number 3415-0001, or equivalent.

The length of the cables between the tape drive and the host must not be more than 15 feet (4.57 meters) total. Table 3- 1 on page 3-2 lists the interface signals from the host to the tape drive, and Table 3-2 on page 3-3 lists the interface signals from the tape drive to the host.

SIGNAL PIN	GROUND PIN	SIGNAL NAME	DEFINITION
J1	J1		
4	3	ILWD	Last Word (terminates write command)
6	5	IW4	Write Data, Chanel 4
8	7	IGO	Go pulse (command strobe)
10	9	IW0	Write Data, Channel 0 (MSB)
12	11	IW1	Write Data, Channel 1
14	13		Reserved
16	15		Reserved
18	17	IREV	Reverse
20	19	IREW	Rewind
22	21	IWP	Write Data, Parity (optional)
24	23	IW7	Write Data, Channel 7
26	25	IW3	Write Data, Channel 3
28	27	IW6	Write Data, Channel 6
30	29	IW2	Write Data, Channel 2
32	31	IW5	Write Data, Channel 5
34	33	IWRT	Write
36	35		Reserved
38	37	IEDIT	Edit
40	39	IERASE	Erase
42	41	IWFM	Write Filemark
44	43		Reserved
46	45	ITAD0	Transport Address 0
J2	J2		
18	17	IFEN	Formatter Enable
24	23	IRWU	Rewind/Unload
46	45	ITAD1	Transport Address 1
48	47	IFAD	Formatter Address
50	49		Reserved

Table 3-1. Host To Tape Drive Interface Signals

SIGNAL PIN	GROUND PIN	SIGNAL NAME	DEFINITION
J1	J1		
2	1	IFBY	Formatter Busy
48	47	IR2	Read Data, Channel 2
50	49	IR3	Read Data, Channel 3
J2	J2		
1	-	IRP	Read Data, Parity
2	-	IR0	Read Data, Channel 0
3	-	IR1	Read Data, Channel 1
4	-	ILDPA	Load Point
6	5	IR4	Read Data, Channel 4
8	7	IR7	Read Data, Channel 7
10	9	IR6	Read Data, Channel 6
12	11	IHER	Hard Error
14	13	IFMK	Filemark
16	15	IDENT	Identification Burst
20	19	IR5	Read Data, Channel 5
22	21	IEOT	End Of Tape
26	25	IHIDEN	3200 Bpi selected (optional)
28	27	IRDY	Ready
30	29	IRWD	Rewinding
32	31	IFPT	File Protected
34	33	IRSTR	Read Strobe
36	35	IWSTR	Write Strobe
38	37	IDBY	Data Busy
40	39	ISPEED	Early EOT Indicator (approx. 50 feet)
42	41	ICER	Correctable Error
44	43	IONL	Online

Table 3-2. Tape Drive To Coupler Interface Signals

3.3. LOGIC LEVELS & ELECTRICAL SPECIFICATIONS

All interface signals are configured as low true signals. That is, the condition represented by the signal name descriptor is true when the signal line is at the low logic level. The low true signal arrangement results in signals being false (at the high logic level) if the signal conductor inadvertently opens or is disconnected.

3.3.1. Logic Level Specifications

True = Low = 0.0 to +0.5 Volts
False = High = +2.5 to +5.0 Volts

3.3.2. Line Receivers (Input Signals)

TTL compatible, Schmitt Trigger
Terminated by 220 ohms to +5 volts and 330 ohms to ground.

3.3.3. Line Drivers (Output Signals)

TTL compatible, type 74LS240.
Sink current = 24 milliamps maximum.
Minimum pulsewidth = 1 microsecond.

3.4. SIGNAL NAME MNEMONICS

Each of the signals in the interface is assigned a descriptor name. The descriptor name is also assigned a logic term mnemonic which serves as an abbreviation of the full descriptor name and assists in remembering the function associated with a particular interface line.

Each logic term mnemonic has an "I" character prefix which denotes that the signal is an interface signal with a negative true characteristic.

3.5. DETAILED INTERFACE DESCRIPTION

The interface architecture is a combination of dedicated signal lines and unidirectional buses. Certain groups of lines act as a bus and information on those lines is qualified by the logic state of one (or more) of the dedicated lines. Some of the dedicated signals have the ability to cause immediate action, overriding the states on other lines.

3.5.1. Host To Tape Drive Interface Signals

3.5.1.1 Unit Address

The formatter is addressed as a physical unit. Its address is selected by a jumper position inside the tape drive. A physical unit address of 0 through 7 may be set by the jumpers.

The tape drive is normally shipped with the jumper installed at W9, such that the formatter responds to unit address 0. The address may be changed by moving the jumper.

Jumper positions are numbered W9 through W16. (The drive address is therefore equal to the W number minus 9).

UNIT ADDRESS	JUMPER INSTALLATION							
	W9	W10	W11	W12	W13	W14	W15	W16
0	I	O	O	O	O	O	O	O
1	O	I	O	O	O	O	O	O
2	O	O	I	O	O	O	O	O
3	O	O	O	I	O	O	O	O
4	O	O	O	O	I	O	O	O
5	O	O	O	O	O	I	O	O
6	O	O	O	O	O	O	I	O
7	O	O	O	O	O	O	O	I
DISABLED	O	O	O	O	O	O	O	O

Table 3-3. Address Jumpers

3.5.2. Address Lines and Formatter Select

Three interface lines are dedicated to the unit address and formatter select function.

- IFAD (Formatter Address)
- ITAD0 (Transport Address bit 0)
- ITAD1 (Transport Address bit 1)

IFAD	ITAD0	ITAD1	SELECTED DRIVE
H	H	H	0
H	H	L	1
H	L	H	2
H	L	L	3
L	H	H	4
L	H	L	5
L	L	H	6
L	L	L	7

Table 3-4. ITAD/IFAD Decoding

The states on the address lines are decoded and will select the formatter if they match the physical unit address set by W9 through W16. Refer to Table 3-4 on page 3-5 for address line decoding.

IFAD and ITAD must be in the desired state before IGO goes low, and must remain at the desired state to keep the formatter selected. When selected, the formatter is logically connected to the host and all formatter receivers and drivers are activated. Unless otherwise specified, the description of all signal lines assume that the formatter is selected.

3.6. DIRECT ACTION LINES

3.6.1. IFEN (Formatter Enable)

This signal enables the formatter when held true. It must be held true during normal operation. When the line is pulsed false for a minimum of 1 microsecond, the formatter is reset. This resetting action is intended for use in clearing Read, Write, Search, Erase Variable or Security Erase command runaway (i.e. a hung-up operation) during Data Busy (IDBY = True). The resetting action pulse is ignored when IDBY is false. Termination of a command occurs within 50 milliseconds and is indicated by the following normal sequence:

IDBY goes false, then IFBY goes false

Pulsing IFEN high can not be used to terminate Rewind, Unload, Erase Fixed and Write Filemark operations. This limitation is intentionally imposed to provide for orderly termination with no loss of tape data.

Any command initiated by the IGO pulse while IFEN is false will be ignored.

3.6.2. IREW (Rewind)

The Rewind operation is initiated by a 1 microsecond minimum pulse on the IREW line, provided that the formatter is Ready, Online and the tape is not at BOT.

If the tape is at BOT, the Rewind signal will be ignored. A Rewind operation does NOT cause IDBY or IFBY to go true. true level on the IFBY or IDBY. When the Rewind operation is initiated, the IRWD status line will go true within 1 microsecond and the IRDY line will go false. Subsequent commands should NOT be issued until IRWD goes false and IRDY goes true.

The Rewind operation moves the tape in the reverse direction at the rewind speed. When the BOT marker is reached, the tape is decelerated, positioned ahead of the BOT marker, and then stopped. The ILDP and IRDY lines are set true and the IRWD line is set false to indicate the end of the Rewind operation.

3.6.3. IRWU (Rewind/Unload)

The rewind/unload operation is similar to the rewind operation, except that when IRWU goes true, the tape drive goes off line and unloads the tape. If the tape is not at BOT, it will be rewound before the unload operation begins.

Some of the industry literature calls the IRWU line by the name IOFL (Off-Line). The function is essentially the same. Host designs which use the IOFL terminology should operate satisfactorily with their IOFL line connected to the IRWU input of the Qualstar tape drive.

3.7. COMMAND INITIATION

3.7.1. IGO (Command Strobe)

On the low-to-high transition of IGO, the formatter samples the states of the command bus lines into its command latch. To provide for proper recognition of the command, the command bus must be stable at least 1 microsecond prior to the rising trailing edge of the IGO pulse. The minimum pulsewidth for IGO is 1 microsecond.

To facilitate streaming while writing and thereby avoid the time penalty of repositioning, the IGO line may also be used to extend the IBGs. During a write operation, if successive write commands cannot be issued within the normal reinsert times, the Qualstar tape drive can be directed to continue running forward at the same speed and NOT enter a repositioning cycle. This method extends the IBG to a maximum of 100 inches, which is equivalent to a reinsert time of 2 seconds for 1600 Bpi (50 ips) and 4 seconds for 3200 Bpi (25 ips).

To extend the IBG, set the command bus for a normal write operation, then assert and hold IGO true until the data to be written is available at the interface. If an extension of the IBG is to be cancelled without a new write command, a No-Operation command should be placed on the command lines before the IGO line is placed false. When cancelled in this manner the IFBY and IDBY lines will sequence in the normal manner but an actual command will not be initiated.

When a command is issued to the formatter from the host, the formatter responds by asserting the IFBY line true. The formatter then performs all of the functions involved with execution of the command. Any errors that are detected during the execution of the command are reported to the host on the IHER or ICER interface lines, as appropriate for that type of command. Upon completion of the command, IDBY goes false. That change of state on the IDBY line notifies the host that it may then issue the next command.

To continue streaming (i.e. avoid a reposition cycle), a new command must be of a similar nature as the previous command. (Example: A Read Forward followed by another Read Forward.) The new command must be received by the formatter after IDBY goes high but before IFBY goes high (i.e., within the reinsert time.)

NOTE

Due to the nature of the Erase Variable and Write Edit operations, repositioning is required regardless of those commands being received during the reinsert time.
--

3.7.2. Command Bus

There are five interface lines for commanding operations involved with writing, reading and erasing the tape. These lines, taken as a group, are known as the "command bus".

The formatter samples the command bus on the low-to-high transition of IGO. The command lines must be stable at least 1 microsecond prior to the low-to-high transition of the IGO pulse, and must remain stable until IGO has fully risen to the high logic level.

Table 3-5 on page 3-8 lists the legal commands and the corresponding states on the command bus. A detailed explanation of the commands is given in the portion of this document which follows the explanation of interface lines.

	IWRT	IREV	IERASE	IWFM	IEDIT
Read Forward Group:					
Read Forward	F	F	F	F	F
Space Forward	F	F	T	F	F
Filemark Search Fwd with Data	F	F	F	T	F
Filemark Search Fwd without Data	F	F	T	T	F
Read Reverse Group:					
Read Reverse (Normal) ¹	F	T	F	F	F
Space Reverse	F	T	T	F	F
Filemark Search Rev with Data	F	T	F	T	F
Filemark Search Rev without Data	F	T	T	T	F
Write/Erase Group:					
Write	T	F	F	F	F
Write Filemark	T	F	T	F	F
Erase Fixed Length	T	F	T	T	F
Erase Variable Length	T	F	T	F	F
Erase Security	T	F	T	T	T
Non-Streaming Group:					
Read Reverse (Edit)	F	T	F	F	T
Write Edit	T	F	F	F	T
No Operation	F	F	T	F	T
Select 1600 Bpi	F	F	T	T	T
Select 3200 Bpi	F	T	T	T	T
T = true, F = false					

Table 3-5. Valid Commands

3.8. COMMAND BUS SIGNAL LINES

3.8.1. IREV (Reverse)

The state of this line specifies the direction of tape motion.

- True = Reverse, False = Forward

3.8.2. IWRT (Write)

The state of this line specifies the mode of operation and data transfer.

- True = Write, False = Read

3.8.3. IWFM (Write Filemark)

A true state on this line specifies that a filemark is to be written on the tape. The IWRT line must also be true in order to write a filemark.

3.8.4. IEDIT (Edit)

This line is a multi-purpose line used to command Edit mode operation, Security Erase, No-Operation and the selection of the recording density. The state of the IEDIT line is taken in conjunction with the states of the other command bus lines, to determine the particular type of command. Refer to Table 3-5 on page 3-8 for a listing of the applicable states of the lines.

The Edit mode allows a block of data to be overwritten for the purpose of revising the data content of the block.

The proper sequence of events for performing the edit of a block is as follows:

1. Perform a Read Reverse Edit command to move back over the block to be edited. This will result in a position in front of the block to be edited with the head positioning optimized for editing.
2. Perform a Write Edit command, writing the revised data in the block being edited. The formatter and tape drive will automatically optimize the turn-off of write current upon completion of the edit, thus avoiding the possibility of recording a transient in the IBG.

To avoid creating problems when using the Edit mode of operation the following precautions are recommended:

1. The revised block should be equal in character count to the record (block) being replaced. The preferred method for determining the character count is for the host to count read strobe pulses (IRSTR line) during the Read Reverse Edit command execution.
2. Avoid attempting a Write Edit command if errors, detected during the execution of the Read Reverse Edit command, imply a loss of character count integrity.
3. Do NOT attempt to edit the same block more than three times. (This helps assure that the IBG will meet tolerances.)

4. Do NOT attempt an editing function using an ordinary Write command.

3.8.5. IERASE (Erase)

This line is a multi-purpose command line used primarily to command the Erase mode of operation. The IERASE line is also used for space operations, filemark search operations, No-Operation and the selection of recording density. The state of the IERASE line is taken in conjunction with states of the other command bus lines to determine the particular type of command. Refer to Table 3-5 on page 3-8 for a listing of the applicable states of these lines.

The erase commands are discussed in more detail in the portion of this document which follows the explanation of interface lines.

At initiation of Space Forward, Space Reverse, File Search Forward without Data and File Search Reverse without Data commands, the assertion of IERASE inhibits Read Strobe (IRSTR) pulses.

3.9. WRITE DATA LINES

The write data lines transfer data to be recorded from the host to the tape drive. One of those lines is dedicated to flagging the last word (character) in a block.

The write data lines consist of:

IW0	Write data, channel 0
OW1	Write data, channel 1
OW2	Write data, channel 2
OW3	Write data, channel 3
IW4	Write data, channel 4
IW5	Write data, channel 5
IW6	Write data, channel 6
IW7	Write data, channel 7
IWP	Write data, channel P
ILWD	Last Word

Table 3-6. Write Data Lines

The eight data bits on those lines plus a parity bit are written in parallel onto the corresponding tracks on tape. IW7 corresponds to the least significant bit of the character. The relationship of data channels to ANSI track numbers and of write data lines to read data lines is shown in Table 3-6 on page 3-10.

QUALSTAR INTERFACE CHANNEL	WRITE DATA LINE	BINARY WEIGHT	ANSI TRACK NUMBER	READ DATA LINE
7	IW7	2^0	2	IR7
6	IW6	2^1	8	IR6
5	IW5	2^2	1	IR5
4	IW4	2^3	9	IR4
3	IW3	2^4	3	IR3
2	IW2	2^5	5	IR2
1	IW1	2^6	6	IR1
0	IW0	2^7	7	IR0
P	IWP	Odd Parity	4	IRP

Table 3-7. Data Channel Correlation

3.9.1. Internal/External Parity Selection

The parity bit information is obtained either from the IWP line (external parity generation) or by a parity generator in the formatter (internal parity generation). The method used is determined by a jumper position inside the tape drive as follows:

PARITY GENERATION METHOD	W2	W3	COMMENTS
External	omit	use	
Internal	use	omit	FactoryDefault

When external parity generation is used, the odd parity information on the IWP line must be generated correctly by the host. The odd parity is generated from the states on the IW0 through IW7 lines.

When internal parity generation is used, the information on the IWP line is ignored by the formatter and parity information is generated by the parity generator on the formatter. This is the parity method configuration normally shipped from the factory.

The ILWD line is a flag bit utilized to indicate the last write data character of a block. (The time for termination of a Write command operation.) This flag is also used to indicate the time for termination of the Erase Variable Length command operation.

The states of ALL of the write data group lines are strobed into the formatter by IWSTR which is generated by the formatter. Therefore, ALL of the write data group signals must adhere to certain setup and hold time requirements. Those requirements are specified in the description of the IWSTR line.

3.10. TAPE DRIVE TO HOST INTERFACE SIGNALS

Two response signals are provided to indicate the stages of formatter activity during execution of commands. The changes of state of these busy signals are used by the host to determine that the formatter has received a command and to initiate the next command.

3.10.1. IFBY (Formatter Busy)

The formatter will place this signal true within 1 microsecond following the rising edge of the IGO pulse. The signal remains true during execution of the command, and goes false upon completion of the command. (The foregoing description applies to legal command situations.) If the type and direction of the next command is different from the command just completed, the drive will reposition the tape.

To maximize streaming, the next command should be issued as soon as IDBY goes false. It is NOT desirable to wait until IFBY goes false before issuing the next command. Streaming avoids the time penalty of repositioning. (Also refer to the explanation of IDBY which follows.)

3.10.2. IDBY (Data Busy)

IDBY goes true after the tape has reached operating speed and, for write commands, when the formatter ready to receive data from the host. It remains true for the duration of the command. IDBY will go true at least 100 microseconds before any data transfer or block detection. The host should inhibit the issuing of commands while the IDBY signal is true.

IDBY goes false immediately after the read head has finished reading the block, or after completion of the appropriate delay required for non-read/write tasks. The host may issue the next command as soon as IDBY goes false. To maintain streaming, the next new command (of the same type and direction as the last previous command) must be received by the formatter within the command reinstruct time following the rising edge of the IDBY signal.

NOTE

Due to the nature of the Erase Variable and Write Edit Operations, repositioning is required regardless of those commands being received during the reinstruct time.
--

A special consideration for the IDBY line is involved with respect to File Search operations (any File Search type of command). Two variations of IDBY line characteristics are prevalent in the industry for File Search operations. The original de facto standard provided for the IDBY line to go from true to false and back to true as each IBG was passed over during the search. This provided a way to count blocks without using read strobes.

The second standard is to leave IDBY true until the filemark is found. This allows IDBY to indicate "end-of-operation" to the host. The Qualstar tape drive may be configured to provide either version of IDBY. The choice is made by a jumper position. This is specified in Table 3-6.

Other industry literature has erroneously referred to the IDBY line with an IDBSY mnemonic. IDBSY is functionally equivalent to the IDBY line description given here.

3.10.3. IDBY Toggling

IDBY TOGGLES DURING FILE SEARCH (AT EACH IBG)	INTERFACE STANDARD	CORRESPONDING JUMPER INSTALLATION	QUALSTAR NORMAL SETTING
Yes	Pertec [®]	W3	Yes
No	Cipher [®]	W4	No

NOTE

The foregoing busy signal descriptions assume the IFEN line is true at the time of the IGO pulse and that it remains true during the command operation. If the formatter is NOT enabled by IFEN, but instead that line is held false, then the IGO pulse is ignored and the IFBY and IDBY lines will remain false.

3.11. SPECIAL STATUS LINES

3.11.1. IDENT (Identification)

This line is pulsed true while an identification (ID) burst is detected on a tape when the drive is set to the 1600 Bpi density. Tapes that comply with the ANSI/IBM requirements for 1600 Bpi will have an ID burst recorded in the BOT area of the tape. The IDENT signal is inactive when the drive is set to the 3200 Bpi density. The presence or absence of an ID burst will NOT prevent the tape drive from reading an otherwise valid tape.

3.11.2. IHER (Hard Error)

This signal will be pulsed true when the formatter determines that one or more of the uncorrectable read error conditions have occurred. This status will be placed on the IHER line while IDBY is true.

The following conditions are considered uncorrectable error conditions:

1. More than one dead track. A dead track is detected when the analog read signal envelope becomes less than the normal threshold value for an excessive time. Dead tracks are normally caused by one or more of the following: media flaw, damaged tape, contaminated tape, debris in the tape path. When this condition occurs, IHER will remain true until the end of the block is read.
2. Detection of a read parity error with NO detection of a dead track. This constitutes an uncorrectable error. When external generation of write data parity (for IWP) is used, this type of error may be more prevalent.
3. Detection of invalid postamble which can be caused by a variety of error situations.

4. Detection of a format error. An example of this type of error is an erroneous preamble.

The IHER indication is inhibited when a filemark is read or for any operation resulting from a command in which the IERASE signal is true. IHER and ICER can be simultaneously true.

3.11.3. ICER (Corrected Error)

This signal is placed true when a single track error correction is performed by the formatter (while IDBY is true). ICER will remain true until IDBY rises (goes false). Only a single dead track is allowed for a read error to qualify as a correctable error. If a true indication is given on the ICER line during a write operation, then that block should be rewritten.

The ICER indication is inhibited when a filemark is read or for any operation resulting from a command in which the IERASE signal is true. IHER and ICER can be simultaneously true.

If a true indication is given on the IHER line during a write operation, then that block should be rewritten.

3.11.4. IFMK (Filemark)

This signal is placed true whenever the formatter reads a valid ANSI/IBM compatible filemark from the tape. This status will be placed on the IFMK line while IDBY is true. If a filemark detection is NOT indicated on the IFMK line during a Write Filemark operation, then the filemark should be rewritten.

3.12. REGULAR STATUS AND CONFIGURATION LINES

NOTE

One of two possible choices for enabling four of the status signals may be chosen according to a jumper position in the formatter.
--

The four signals affected by this arrangement are:

- IONL (On-Line)
- IRWD (Rewinding)
- IFPT (File Protect)
- ISPEED (Used as a special optional signal)

The jumper positions affecting those signals are W5 and W6. The jumper position corresponding to a particular enabling condition is shown in Table 3-7.

JUMPER POSITION	Corresponding enable conditions required to assert a true on status lines (IONL, IRWD, IFPT, ISPEED)	FACTORY DEFAULT
W5	Formatter selected	yes
W6	Formatter selected, tape loaded and not rewinding	no

Table 3-8. Enable Choices for Status Lines

3.12.1. IRDY (Ready)

This is a signal that is true only when the tape is loaded and not rewinding or unloading, and the formatter is ready to receive commands.

The IRDY signal will be placed false for any of the following conditions or events:

- The tape is rewinding.
- The tape is NOT loaded or is being unloaded.
- Detection of a failure which causes the tape drive and/or formatter to be unusable.

It is recommended that the host utilize a true on the IRDY line as a necessary requirement for initiating any operation except Unload.

3.12.2. IONL (On-Line)

This signal, when true, indicates that the tape drive may be commanded by the interface lines. It is provided to assure compatibility with those hosts which expect the IONL signal.

One of two possible choices for the enabling of this signal may be chosen according to a jumper position in the formatter. This was described in a preceding portion of this document. The following description assumes that the applicable enabling condition exists.

There is no front panel switch specifically dedicated to placing the tape drive online. The tape drive firmware emulates an operator placing the tape drive online when a loading operation is successful.

NOTE

IONL may be terminated from the front panel switches. There is also a method of placing the tape drive back online after an operator aborts a runaway situation. This is described in a following section of this document.

The IONL signal will be placed true when the formatter firmware determines that the online condition can be asserted.

The IONL signal will be placed false when an unload operation is initiated or when the enabling condition ceases to exist. (Example: The formatter is deselected by the interface. That will disable the IONL signal, causing it to become false.)

When the formatter may not be commanded by the interface lines (i.e. loss of the online condition), then the IRDY signal will also be placed false.

3.12.3. IRWD (Rewinding)

One of two methods for the enabling of this signal may be chosen according to a jumper position in the formatter. This was described in a preceding portion of this document. The following description assumes that the applicable enabling condition exists.

The IRWD signal will be true when the tape drive is rewinding the tape. IRWD will go true within 1 microsecond after IREW goes true, and will remain true until the tape is positioned at BOT.

Whenever the tape is rewinding, the IRDY signal is false.

3.12.4. IFPT (File Protect)

One of two methods for the enabling of this signal may be chosen according to a jumper position in the formatter. This was described in a preceding portion of this document. The following description assumes that the applicable enabling condition exists.

A true level on this signal line indicates that the tape drive has been placed in the File Protect state by the operator. When the tape drive is in the File Protect state, the write and erase capability is disabled. If Write or Erase commands are issued to the formatter while in the File Protect state, then a File Protect Error is indicated on the front panel of the tape drive (except at Load Point). Refer to the Qualstar User's Manual for information regarding File Protect error indications and recovery.

The FPT switch on the tape drive front panel is used to change the File Protect state of the tape drive. Changing the File Protect state is possible only when the tape is at load point (Load indicator illuminated). Upon loading the tape, the tape drive is protected (i.e. in the File Protect state). Pressing the FPT switch toggles the File Protect state. The indicator associated with the FPT switch is illuminated when the tape drive is in the File Protect state.

3.12.5. ILDP (Load Point)

This signal line is placed true whenever the BOT marker on the tape is logically at the reflective marker sensor. This condition is referred to as Load Point or BOT. The Qualstar streaming tape drive uses repositioning. When a command is executed with the tape physically at BOT, the ILDP status will remain true during the required repositioning. When the repositioning has been completed, and the tape is up to speed with the physical BOT marker moving away from the reflective marker sensor, the ILDP signal will go false.

If a Reverse direction command occurs causing tape to move to BOT, at the BOT point the command execution is completed and the ILDP line is placed true.

If a Reverse direction command is issued with the tape already at BOT (an illegal attempt), the ILDP line will remain true. The command execution will only occur to the extent of quickly sequencing the IFBY and IDBY signals. This is done to maintain compatibility with other commands and with existing host designs.

The ILDP signal goes true only at the very end of a rewind operation. During rewind, it will not be pulsed true momentarily as the physical BOT marker is first detected by sensor. Only when positioning has been completed and the tape is logically at BOT will the ILDP line be placed true.

The formatter firmware automatically compensates for the small physical distance between the physical reflective marker sensor and the physical read/write head.

3.12.6. IEOT (End of Tape)

This signal line is placed true to indicate that the end-of-tape (EOT) marker has passed by the reflective marker sensor while moving tape in the forward direction.

This signal line is placed false either during a rewind or reverse direction operation when the EOT marker passes the reflective marker sensor while the tape is moving in the reverse direction.

The formatter firmware does NOT automatically compensate for the small physical distance between the physical reflective marker sensor and the physical read/write head.

3.12.7. ISPEED (Early EOT - A Special Signal)

This signal has very little use in most drives as it simply confirms the drive has been commanded to operate at the higher of two speeds for a given data density. Qualstar tape drives operate at only one speed for any given density. We therefore have no need for this signal (nor do most controllers since they know what speed the drive was commanded to operate at).

Qualstar has chosen to provide some very useful information on this line. The ISPEED signal is used to indicate the proximity of the end of tape. This signal will be set true whenever there is approximately fifty feet or less of tape remaining on the supply reel. This is without regard to data density or reel size. The indication is based on the diameter of the tape pack on the supply reel. The fifty feet is based on standard 1.5 mil thick tape. There is some hysteresis built into the logic so that the signal will not oscillate when repositioning near the 50 foot threshold.

This signal can be used by hosts and/or programs which buffer large amounts of data to be written to the tape drive. It is possible that a full buffer of data will not fit on the tape remaining after the physical EOT tab passes (indicated by IEOT). The presence of the Early EOT signal (ISPEED true) should be used to limit the size of the write data buffer from that point on to prevent writing off the end of the tape (the drive must allow the user to do this).

This feature is not an industry standard and is unique to Qualstar Products.

3.12.8. IHIDEN (High Density)

This signal line is an optional feature that may be enabled by installation of a jumper inside the tape drive. When W9 is installed, the signal is enabled and the following description is applicable. When W9 is omitted the signal line is an open circuit.

This signal line is placed true whenever the 3200 Bpi data density is selected. The IHIDEN line is placed false whenever the 1600 Bpi data density is selected.

The IHIDEN line uses the same connector pins that are assigned to the INRZ signal in other industry products. Since the INRZ signal is used to indicate a type of data density, most host designs and device driver software can readily accommodate this optional feature.

3.13. WRITE STROBE LINE (IWSTR)

This output signal is a true going pulse with a nominal duration of 1.56 microseconds. The purpose of the signal is to strobe the write data (lines IWD0-IWD7) into the formatter. The data is transferred (strobed) by the low-to-high transition of the pulse. The repetition rate of the IWSTR pulse is 12.5 microseconds (80 kilohertz).

Character data on the Write Data lines (IW0 through IW7, IWP) and the last Word flag (ILWD) must be stable at least 300 nanoseconds before the rising edge of the IWSTR pulse. The Write Data lines and the Last Word flag must then be held stable at least until the rising edge of the IWSTR pulse has fully risen to the high logic level. (i.e., the hold time is 0 nanoseconds.)

3.13.1. Write Strobe Timing Diagram

Write strobe timing is shown in Figure 3-1 on page 3-19.

NOTE

The last Word flag bit on the ILWD line is only placed true for the last write data character of a block. At the strobing time of all other write data characters the ILWD line must be held false. Undesirable transitions (spikes) on the ILWD line will be ignored provided that the previously specified set-up and hold times are met.

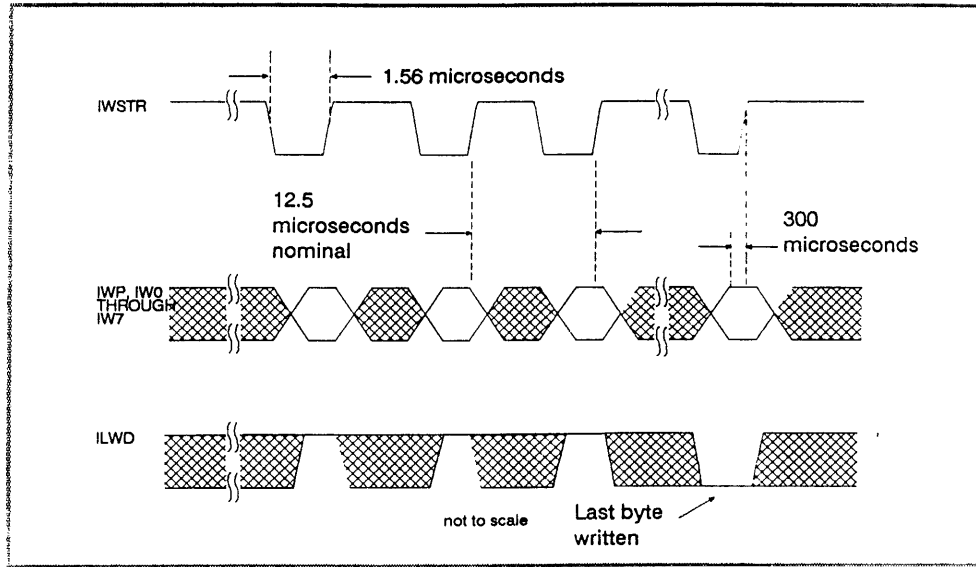

Figure 3-1. Write Strobe Timing Diagram

IR0 (MSB)	Read data, channel 0
IR1	Read data, channel 1
IR2	Read data, channel 2
IR3	Read data, channel 3
IR4	Read data, channel 4
IR5	Read data, channel 5
IR6	Read data, channel 6
IR7 (LSB)	Read data, channel 7
IRP	Read data, channel P

Table 3-9. Read Data Signals

3.14. READ DATA LINES

There are a total nine output lines that are devoted to conveying the character data read from the tape. The Read data lines are shown in Table 3-9 on page 3-19.

Lines IR0 through IR7 transmit read data from the formatter to the host. IR7 corresponds to the least significant bit of the character. The odd parity information read from the tape is transmitted from the formatter to the host on the IRP line. The information on the read data lines during an erase operation.

3.15. READ STROBE LINE (IRSTR)

The purpose of this output signal is to strobe the read data (IR0 through IR7, IRP) into the host. The signal is a true going pulse with a nominal duration of 2.36 microseconds.

The repetition rate of pulses on the IRSTR line is affected by pulse jitter related to the instantaneous speed variation (ISV) of the tape while the data was recorded, tape ISV during readback, and jitter introduced by the read electronics. ISV and dynamic skew result in short-term variations in the IRSTR pulse repetition rate. The read strobe period varies from 10 to 15 microseconds, with a nominal of 12.5 microseconds.

A loss of read strobe should NOT be used to define the end of a command, and doing so will cause problems. Some types of hard errors can result in loss of read strobe pulses. Also, some types of commands do not result in the output of any read strobe pulses. Only the low-to-high transition of the IDBY line should be used to determine the end of a command.

3.16. COMMAND DESCRIPTIONS

3.16.1. Read Forward

This command instructs the tape drive to read the next block in the forward direction. If no data is present on the tape after 25 feet, the drive will automatically terminate the operation and stop the tape.

The data and parity read from the tape is sent to the host along with Read Strokes (IRSTR). During read operations, ID bursts, errors, and filemarks may be detected.

Note that it is possible to read right off the end of the tape.

The read threshold is automatically optimized to provide for the best data reliability.

3.16.2. Read Reverse

This command is identical to the read forward command except that the tape moves in the reverse direction. If this command were executed after an erase security operation (entire tape is blank), the drive would continue reading until the BOT tab is encountered.

A read reverse into BOT terminates the read operation. However, ILDP is set true before IDBY goes false so that the host can determine this condition has arisen.

3.16.3. Read Reverse Edit

This command instructs the tape drive to read one block in the reverse direction and prepare itself for an Edit mode (editing) rewrite of that block.

Edit operations apply only to Read Reverse. The Read Reverse Edit operation is the same as a Read Reverse except the positioning of the tape is optimized to allow for a Write Edit as the next command.

3.16.4. Write

The Write command instructs the tape drive to write a block in the forward direction. The block is terminated by setting the ILWD signal true during the last character of the data to be written on the tape. The block length can be from one character to the full length of the tape. If ILWD is held true from the time IDBY goes true, the drive will write a one-character block.

Data from the host is written onto the tape. The formatter automatically generates the required interblock gaps plus the preamble field and the postamble field. During write operations, the erase head is also energized to assure complete erasure of previously written data. Writing is possible only in the forward direction.

When writing from BOT at 1600 Bpi, the drive automatically records an ANSI/IBM compatible ID burst.

If the host ignores the end of tape signal (IEOT), it is possible to record until all the tape has come off the supply reel.

During Write operations, the read circuitry is enabled to allow on-the-fly error checking. Because the read head gap is 0.3 inch down tape from the write head, the read data will be delayed approximately 6 milliseconds at 1600 Bpi. During write operations, the read threshold is set high to minimize the effects of write/read crosstalk.

3.16.5. Write Edit

This command instructs the tape drive to rewrite the block just read by the preceding Read Reverse Edit command. The Write Edit command must always be preceded by a Read Reverse Edit command. The number of characters in the revised (edited) block must equal the number of characters in the block read by the Read Reverse Edit operation. The revised block is terminated by setting the ILWD signal true during the last character of the data to be written on the tape.

This command appears to be identical to a normal write operation but it does differ significantly. Because it must not destroy the following data block, streaming is disabled, and the drive will immediately remove erase and write power after the postamble has been written. It will execute pending commands only after repositioning the tape.

3.16.6. Write Filemark

This command causes the drive to erase 3.5 inches of tape and record a special mark on the tape (the filemark). The formatter does not generate write strobes (IWSTR) and no data is transferred from the host. In addition to the filemark gap, an ANSI/IBM

compatible IBG of 0.6 inch is generated. During a Write Filemark operation, the read circuits detect the filemark.

NOTE

If IFMK does not go true at the end of this command, then the filemark must be rewritten. Erase the defective portion of the tape media and attempt to write the filemark on a different (forward) portion of the tape.

3.16.7. Variable Length Erase

This command instructs the tape drive to erase a length of tape as determined by the host. This command is identical to the write command except that only the erase head is energized. During a variable length erase operation, the formatter generates write strobes which the host may use to determine the length of the erased area on the tape.

The command is terminated by setting the ILWD signal true at the particular Write Strobe pulse that corresponds with the desired length of erased tape.

3.16.8. Fixed Length Erase

This command causes the tape drive to erase a fixed length of tape of about 3.5 inches. The formatter does not generate write strobes. At the end of the command, the formatter generates a normal IBG of 0.6 inch.

3.16.9. Security Erase

This command instructs the tape drive to erase all of the tape from the point where the command is received to 15 feet beyond the end-of-tape (EOT) marker.

NOTE

The Erase Fixed and Erase Variable operations cannot be performed from BOT. The only erase operation permitted at BOT is Erase Security, which will erase the Identification (ID) burst.

3.16.10. Space Forward (Reverse) Commands

These commands instruct the tape drive to skip over the next data block. The Space Forward and Space Reverse commands are identical to Read Forward and Read Reverse except that read strobes (IRSTR) and error indications (IHER, ICER) are inhibited. These commands are intended for moving tape forward or reverse one block per command, thereby positioning the tape to a new data block. Filemarks are reported when detected during space commands.

3.16.11. Filemark Search Forward (Reverse) With Data

These commands instruct the tape drive to move tape forward (or reverse) until a filemark is detected. During the search, read data, read strobes, IHER and ICER are enabled.

A forward filemark search will continue reading the tape until a filemark is detected, even if it means running off the end of the tape. Reverse filemark searches will automatically terminate at BOT.

Filemark Search commands are automatically terminated by the following:

- A filemark is found;
- BOT is encountered while running in the reverse direction.

Upon completion of the search, the tape will be positioned as if a read forward or read reverse operation had just been performed over the filemark. A forward search will leave the tape positioned downstream from the filemark and a reverse search will leave the tape positioned upstream of the filemark.

3.16.12. Filemark Search Forward (Reverse) Without Data

These commands are identical to the Filemark Search With Data commands except that IRSTR, IHER and ICER are disabled.

3.16.13. No-Operation

This command instructs the tape drive to perform a “No-Operation”. After receiving this command, the formatter toggles the IFBY and IDBY signals. If tape motion is in progress, such as would occur if the No-Operation command were received during the reinstruct time, the tape will be repositioned.

This operation, also called a NOP, has two purposes:

1. When the IGO line is being used to obtain extended IBG, the NOP provides a means to cleanly escape from the situation where the IGO line has been asserted and held true, but write data did NOT become available when expected.
2. The NOP command allows drive compatibility with hosts sending Write Sync commands to tape drives with built-in cache buffers. The Write Sync command format is the same as the NOP format, and is used to empty the cache buffer onto tape. Non-cache tape drives must be able to respond with a NOP to avoid compatibility problems.

3.16.14. Select 3200 Bpi

This command instructs the tape drive to select the 3200 Bpi data density and the 25 ips tape speed. The command will be accepted only while the tape is positioned at BOT.

3.16.15. Select 1600 Bpi

This command instructs the tape drive to select the 1600 Bpi data density and the 50 ips tape speed. The command will be accepted only while the tape is positioned at BOT.

The 1600 Bpi data density is the default density unless the tape drive is instructed otherwise by a command or the 3200 front panel switch.

3.17. OPERATIONAL CONSIDERATIONS

This section discusses various items related to interface characteristics and operational considerations.

3.17.1. Illegal Command Situations

Not all states of the command bus are valid commands. Refer to Table 3-5 on page 3-8. If the tape drive receives an undefined command, then it will respond to that situation the same as if it were a NOP command.

A common illegal command situation is the receipt of a Write or Erase command when the tape drive is file-protected. When this occurs, the IFBY line will be reset. The FPT indicator will flash on and off until the operator presses the FPT switch. If the tape is not at BOT, the drive will rewind the tape. If a subsequent command is received, the IFBY line will remain true until the fault is reset by the operator. After resetting the fault, the drive will remain write protected. Pressing the FPT switch a second time will then unprotect the drive and enable writing.

The drive responds to other illegal commands by toggling IFBY true for about 50 milliseconds. Tape motion or toggling of IDBY will not occur.

3.17.2. Escape From Runaway Situations

3.17.2.1 Using IFEN

The IFEN line will clear certain types of runaway situations as discussed in a preceding section of this document.

An occasion where IFEN is not applicable is when the software program (controlling the host plus tape drive) is doing the wrong thing and does not respond to interruption. This is a common problem with poorly designed software. Taking the tape drive offline is usually the only clean method of dealing with such a situation. Host runaway can also occur with some designs.

3.17.2.2 Aborting from the Front Panel

Any operation may be cleanly interrupted by the operator at reinstruct time by pressing and holding the 3200 front panel switch. This causes the tape drive to reposition the tape upon completion of the current operation. If the 3200 switch is still pressed when the tape stops, the drive will go offline for five seconds, and then come back online. During this five second interval, the IRDY and IONL signals will go false. In most cases, this will interrupt the software. This will also work for some types of host runaway.

A File Search operation will only terminate when a filemark is found. Thus, a reinstruct time may not occur for a File Search runaway (e.g., no filemark on a tape.) Pressing and holding both the FPT and 3200 front panel switches until the tape stops will abort a Filemark Search operation cleanly between data blocks.

3.17.2.3 Aborting Read Operations

There is no method for manually aborting read operations in the middle of a block, as this would destroy the positioning information needed to read or write the next block. Read and Space Forward operations will automatically abort after 25 feet of blank tape. Read reverse operations are automatically terminated at the BOT marker.

3.17.2.4 Aborting Write, Variable Erase, and Security Erase Operations

Write, Erase Variable Length and Security Erase operations can be manually aborted in the middle of their operation. This gives the operator a means to terminate a runaway condition in which Last Word (ILWD) is never sent. To accomplish this, the operator must hold both the FPT and 3200 front panel switches until the tape begins repositioning. If the 3200 switch is held depressed as the tape comes to a complete stop, the tape drive will go offline for five seconds before going back online.

Aborted write operations always write the proper IBM/ANSI postamble so that the aborted block does not cause subsequent read errors. Its block length will, however, be less than expected.

Whenever the tape drive is in the idle state with tape loaded but at BOT, pressing the 3200 switch will place the tape drive offline for five seconds. The 3200 switch must be released before the tape drive will accept another command.

There is no visual indication that the tape drive is offline. The tape drive will go back online automatically in five seconds, assuming that no other faults or problems exist.

3.17.3. Operating Error Situations

The tape drive detects certain operator errors, host errors and tape drive faults. Refer to the Qualstar User's Manual for a full discussion of these error situations and the front panel indications.

The tape drive will make three attempts before reporting a position fault.

Read after write faults are reported on the IHER and ICER lines as described in a preceding section of this document.

3.17.4. Power On Transients

If the tape is in contact with the head at the time the tape drive power is applied, there is a possibility of writing a transient onto the tape. If the tape is threaded and past the BOT marker, make certain that there is at least 1/8 inch air gap between the tape and head before applying power. Normally the tape is NOT loaded at the time power is applied.

There is NO concern regarding inadvertent writing of a transient on the tape if power is lost or shut off while tape is loaded.

3.17.5. Extended Interblock Gaps

The use of IBGs longer than 0.6 inch (valid only during write operations) is a method of avoiding the time penalty of repositioning. This is of value only for situations where the host computer and host can not handle commands and data quickly enough to maintain streaming with the standard IBG length.

The disadvantage of extended IBG use is that the total storage capacity of a reel of tape is reduced.

If the host cannot issue commands plus data with sufficient speed to maintain streaming with the maximum length IBG selected, then an extended IBG should not be used. If throughput of the tape drive is unimportant, then the time required for repositioning is also of no concern.

One method for writing extended gaps is discussed in the detailed description of the IGO line in a preceding section of this document. Another method of obtaining extended IBG is described in the following paragraph.

There are two switches located on the Write PCBA for setting the length of the IBG that will be written on tape. The minimum IBG is the standard 0.6 inch nominal. The maximum allowed IBG is determined by the switch settings. The actual IBG is determined by the host's response time from IDBY going false to the issuance of the next Write command by an IGO pulse. Table 3-10 on page 3-26 lists the available choices of maximum write IBGs and the corresponding maximum reinsert times.

MAXIMUM WRITE IBG	SWITCHES		MAXIMUM REINSTRUCT TIME AT SW-A	
	S3	S4	1600Bpi, 50 ips	3200 Bpi, 25 ips
INCHES				
0.6	off	off	6	12
1.8	off	ON	30	60
5.4	ON	off	102	240
16.2	ON	ON	318	636

Table 3-10. Extended Gap Switch Settings

NOTE

The indicated times are the maximum time which can elapse between the end of a write operation (IDBY going FALSE) and the issuance of a new WRITE command (by an IGO pulse) without entering into a reposition cycle.

4. THEORY OF OPERATION

This section is designed to provide an in-depth description of the functional sub-modules comprising the Qualstar Tape Drive. References are made to circuit element designators to be found on the respective schematics as found in the Appendix of this Manual.

4.1. POWER PCBA (Schematic 500088)

The Power PCBA (Schematic 500088) contains the following circuits:

- ± 15 volt regulators;
- +5 volt regulators;
- +19 volt unregulated supply;
- +32 volts unregulated supply.
- Power Failure Detect
- Motion Control

The power transformer has one center-tapped secondary winding for the ± 15 volt regulator and the +19 volt unregulated supply, and a second center-tapped winding which is used to for the +5 volt regulator and for the +32 volts unregulated supply.

4.1.1. ± 15 Volt Supplies

The secondary AC power is full-wave rectified by bridge network BR1. The unregulated outputs are connected to two, three-terminal regulators, U1 and U2. These devices will provide regulated ± 15 volts to the complete system. The common ground from the transformer center tap is designated as Analog Ground. The Analog and Digital grounds are tied together by a 15 ohm, 1/2 watt resistor.

4.1.2. +19 Volts

The positive output from BR1 is routed through Zener diode VR1 as raw +19 volts to the Read PCBA where it is regulated down to +12 volts.

4.1.3. +32 Volts

The other transformer secondary outputs are rectified via diodes CR5 and CR6 to generate the unregulated +32 volts used as primary power for the brushless DC Motors used in the servo system.

4.1.4. +5 Volts

The unregulated +32 volts is also used to power a switching regulator which provides the primary +5 volts required for the digital section of the system. The +32 volts is connected through fuse F1 into a sub-regulator comprised of R3, C8 and VR2. This

provides the + 15 volt power required for the switching regulator chip U3. Transistor Q6 provides the start-up signal necessary for the switch. Once the switch is running, Q6 is no longer required.

The network Q4, R4 and R5 provide overcurrent sensing for the supply. If the supply load draws too much current, the voltage drop across R4/R5 increases V_{be} of Q4, resulting in the collector of Q4 rising toward 32 volts. This signal is connected via R16 to pin 6 of the switching circuit U3, and causes the device to shut down. The switch operates at a frequency of 20 - 22 KHz.

Transistors Q2 and Q3 provide the level shifting and buffering for the series pass transistor Q1, providing sufficient current drive to meet the load requirements for the supply. The output of the series pass element is connected to a fast recovery diode (necessary for efficient operation) through the swinging inductor L1. The output of the inductor is the + 5 volt output from the supply, with low inductance capacitors C14 and C15 providing the main output filtering.

The output level is adjusted by means of potentiometer R24. U4 and Q5 provide crowbar protection against high voltages being sustained at the supply output. If V_{out} is detected higher than 6.2 to 6.5 volts, U4 pin 2 will fire SCR Q5 which will short the output of the supply. The switch also receives the output from U4 pin 2 which will cause it to shut down. If the failure mode is such that Q1 cannot shut down, then the fuse F1 will blow.

4.1.5. Power Failure Detect

The transformer secondary taps used to provide the + 32 volts are or'ed via diodes CR3 and CR4. The output, BRAKEPWR, is currently not used but is available in the event that external motor braking is ever required. The signal is also summed, through R25 in amplifier U5B, with the output of U5A. The input to comparator U5A is connected to the fan return signal, and detects whether the fan is operational or not by monitoring the fan return current through resistor R1. The output of U5B, conditioned through U5C, then provides a POWERFAIL indication. This signal is detected by the microprocessor, and results in the drive being shut down.

4.1.6. Motion Control

The motion control or servo control circuitry is also located on the Power PCBA, and is shown on sheet 2 of the schematic. The servo system for the tape drive is made up of two brushless DC Motors – one for the take up and the other for the supply reel. Each motor rotor contains eight magnets arranged around their circumferences. Three Hall Effect sensors are mounted beneath the rotors in such a manner as to generate a three-phase signal. With the eight magnets and three sensors, each rotor revolution is divided into twenty four discrete time slices. The time slices are used to control the commutation of the motor.

4.1.6.1 Hall Sensors

Three Hall sensors are mounted on each Hall PCBA. One Hall PCBA is mounted beneath the supply motor, and one beneath the take up motor. Each sensor is a three terminal device powered by + 15 volts, and each has an open collector output. Because the circuitry is the same for the supply and take up motors, only the take up circuitry will be described.

The take up motor is used to control the speed of the tape, and the supply motor is used to maintain a tension of eight ounces (as measured at the head). When the tape is in motion, the microprocessor computes the amount of tape on each reel by counting the number of tachometer pulses per quarter turn of the tape hubs. From this, the microprocessor computes a number which causes the supply motor to maintain the specified tape tension. The motors are always driven to oppose one another and thus prevent tape spillage.

The outputs of the Hall sensors are terminated by 2.2K pull-up resistors in RN1. In the take up circuitry, the signals are then connected to the A0 - A2 lines of the PROM U11. A3 of the PROM is connected to a signal TUMCW (take up motor clockwise) which is dependent on the direction of rotation of the motor. A4 is connected to the wire-or'ed outputs of the open collector comparators U8B and U8C. The input TUMON/ is controlled by the Microprocessor, such that whenever it is on, it will cause the output on U8C pin 14 to be low and inhibits any power to the motor. When the TUMON/ signal is low, U8C pin 14 goes open state, allowing U8B pin 1 to control the input to pin 14 of the PROM U11.

These signals, together with position data from the Hall sensors, directional data from TUMCW, and an On/Off signal, are decoded by the PROM to provide six signals which determine which transistors in the three phase bridge are to be energized to apply current to the motor.

4.1.6.2 Motor Control

The three phase bridge comprises the series transistor pairs: Q13- Q14, Q15-Q16 and Q17-Q18. Only one transistor in each of these pairs may be switched on at any one time or else they will burn out. The algorithm is derived such that at any given time, only one transistor from the top trio (Q13, Q15, Q17) and one from the bottom trio (Q14, Q16, Q18) will energized. Thus, the three motor signals will always be in different states – one high, one low, and one floating (both transistors turned off). The device U12 is six Darlington pair level shifters which convert the TTL outputs from the PROM to the 32 volts required for the transistor drive.

Protection is provided in the form of flyback diodes (CR20 through CR25) in series with the transistor collectors, and shunt diodes (CR26 through CR31) to the power supply rails to shunt off the flyback currents resulting from the windings being turned off. The emitters of the three lower transistors are not returned directly to ground, but are connected to ground through a 1/2 ohm, 5 watt resistor R70.

This resistor senses the amount of current flowing in the motor. When the motor is shut off, a flyback current exists as the inductor tries to maintain current flow. The current stops flowing through the NPN transistors and starts to flow through the clamp diodes. This results in an opposite polarity current flowing through resistor R120, a 1/2 ohm, 1 watt resistor to ground. While the motor is actively turned on, a voltage is developed across R70 which is directly proportional to the motor current.

While the motor is off, or “coasting”, an equal and opposite voltage is developed across R120. The duty cycle of the motor varies depending on how much torque is required from the motor. The ratio of the on/off times of both R70 and R120 is directly proportional to this duty cycle. The resistor voltages are summed in U6B and filtered. This signal is available at TP2 and has a sensitivity of -3.33 volts per ampere.

The control signal TUCMD (take up motor command) is a 0 to 10 volt signal which is generated by a D/A converter on the Write PCBA. This is the Demand signal which specifies the amount of motor current required. A voltage of + 3.33 volts at TUCMD demands a motor current of 1 ampere. This signal is summed with the measured motor current at the input to Integrator U7B, and provides a current error signal for the closed loop servo.

The output of U7B is clamped by diode CR33 to prevent the output from swinging negative. The output of Integrator U7B is applied to the negative input of Comparator U8B. The positive input is driven by the signal RAMP. This is a 15 KHz, 0 to 10 volt sawtooth signal. The resultant output from U8B pin 1 will be a 15 KHz pulse train the duty cycle of which is proportional to the amplitude of the error signal.

The ground pin for U8 is connected to -15 volts through diode CR34 and resistor R123, to provide a -0.7 volt bias on the ground of the device. This ensures that inputs 4 and 6, which are clamped to a minimum of -0.7 volts, will not traverse below the device ground level.

4.2. READ FORMATTER PCBA (Schematic 500048)

This card contains all the circuitry to sense and decode the read data from the read head. The read circuitry comprises nine identical sets of circuits to decode the eight data channels plus the parity channel. The circuitry on the card is divided vertically according to the track.

4.2.1. Read Channels

As all nine channels are identical, only one channel will be described. The designators assigned RX02, UX03 etc., are representative of all designators.

The read head signals are routed to the PCBA through connector J10 and are received into the differential amplifier UX01. The differential output from the amplifier is passed through some AC coupling and low pass filtering into the differential amplifier UX02. UX02A output is differentiated by the passive differentiator CX07 and RX13, which provides a 6 db per octave slope, increasing with frequency. This causes a 90 degree phase shift. The gain of the stage is set by the feedback resistor RX11 which also rolls off the high frequencies in order to reduce the noise. This signal is AC coupled through CX11 and RX17 to TPX02. This test point is used to verify signal presence.

The signal is filtered through the noise snubber RX18 and CX12 to the input of a comparator which is referenced to digital ground. The comparator is configured as a zero crossing detector, whose hysteresis is compensated for by CX13 and RX20. The output is pulled up to +5v by RNX. The squarewave output is available at TPX03.

The output from UX02 is also connected through a low pass filter comprised of RX15 and CX10. The signal at TPX01 is used to set the gain of the amplifiers via trimpot RX04. This signal is connected in parallel to both inputs of a dual comparator configured as a threshold detector. Whenever the signal is more positive than + threshold and more negative than - threshold, the ENvelope signal goes low, indicating sufficient signal is present to make the output of the zero crossing detector valid.

All the operational amplifiers are connected between +12 volts and ground, requiring an input bias of +6v as the half voltage. The signals at TPX01 and TPX02 are clamped

to 3.6 volts by diodes CRX01 through CRX04 to prevent damage to the comparator inputs should excessive signal be detected.

4.2.1.1 Threshold Generation

The threshold generation circuitry is made up of a CMOS 1 of 8 decoder (U39) with a high true output which will settle at five volts. One of the outputs Y0 through Y7 will always be true. Which one is determined by the state of three signals:

Hidden

This is true when 3200 bps is selected.

Threshold

This is dependent on the sensitivity selected.

Read

This signal is true during read operations.

The outputs of U39 are summed into the input of U28 through resistors which are hand-selected to provide the precise threshold voltages required for each of the selected conditions.

The output signal is filtered by R9, C7 and C31, and is limited by Zener diode VR3 to 3.6 volts.

MODE	Y#	R#	OHMS	VOLTS
1600 Write	0	R17	10.0K	500mV
	1	R16	10.0K	500mV
1600 Read	2	R15	12.1K	413mV
	3	R14	23.2K	216mV
3200 Write	4	R13	33.2K	150mV
	5	R12	33.2K	150mV
3200 Read	6	R11	40.0K	100mV
	7	R10	100K	50mV

Table 4-1. Threshold Voltages

4.2.1.2 Envelope Detection

The ENV output signals for each channel are wire-or'ed together with the exception of two channels. These channels, 0 and 5, are used to verify when the Envelope has truly gone away. The wire-or'ed outputs from the other channels go to the front end decoders to indicate data valid.

4.2.1.3 Data Discrimination

The zero crossing detect outputs from the analog section are clocked into registers U17 and U19 by the signal TRACKCLK. This signal is generated by a tracking VCO operating at 24 times the data rate. The first level of buffering is to ensure that the data meets the set up time requirements of the PED chip. There are two versions of the PED chip depending on which version of FIFO is used:

- **B** - used with the 74HCT4105 FIFO
- **B2** - used with the 3341 FIFO

The differences are primarily in the manner they are controlled, as shown in Table 4-2.

	74HC4105	3341
Master Reset	High	Low
Output Enable	Ground	-12 volts
Tri-state	Yes	No
Shift out	Low	High

Table 4-2

The zero crossing detect signal is the data in and is clocked through another flip-flop to create data out. The input and output are then exclusive-or'ed. If there is any change on the input for a period of one track clock, a pulse of duration one track clock period is generated. The ACQUIRE input modifies the operation to only detect a zero data bit from the tape. This is used for synchronization to the preamble which is comprised of forty zeros and a one.

4.2.2. PED Chip Signals

4.2.2.1 Direction

Forward or reverse tape motion.

4.2.2.2 Trackclk

Used internally to prevent glitching on some of the outputs due to the speed of the FIFO.

4.2.2.3 Datavalid (output)

Envelope has occurred during a window time. Input from Envelope indicates that the zero crossing being received is valid. Zero crossing can fluctuate but if not associated with Envelope is not valid. This eliminates noise.

4.2.2.4 Output Enable (not used)

4.2.2.5 Window

The window signal tracks the 24X signal to determine that the data cell size is between the cell size limits of 75% to 125% of nominal cell size.

4.2.2.6 Error Out

This is set if the window size is not within the specified tolerance.

4.2.2.7 Transition Detect

If the window is valid, there will be a transition detect signal.

4.2.2.8 Data Strobe

This is the inverted transition detect and'ed with MR/.

4.2.2.9 Data Out

Data in delayed by 1 register D strobe used to shift the data plus error to the FIFO. When in the Acquire mode, only zeros are locked on until it is certain that data is locked on. At this time the ACQUIRE signal is removed so that the preamble can be detected.

4.3. WRITE CONTROLLER PCBA (Schematic 500058)

The Write Formatter PCBA contains all the write formatter circuitry plus the digital section, which is the control center for the complete drive.

4.3.1. Microprocessor

The controller for the Qualstar Tape Drive is an Intel 8085 microprocessor U45. The clock for the microprocessor is provided by crystal Y1 which oscillates at a frequency of 5.12 MHz. This is divided internally in the microprocessor and provides the System clock at a frequency of 2.65 MHz. This is further divided by flip-flop U38B to provide a 16XCLK signal of 1.2 MHz, which is sixteen times the data rate. The composite Address/Data lines are demultiplexed through U26 using the ALE signal from the microprocessor to create the lower eight address lines. The control firmware resides in U39, a 2764 8K x 8 bit PROM.

4.3.2. Address Decode

Address decoding is done at 1 of 8 decoders U9, U10, and U11 (74LS138). The high order address bits are used to select 4K segments, enabling functional blocks of addressing. The first two segments, decoded as CE0 and CE2 (Chip Enable 0 and 2), are and'ed together to create CEP, which is Chip Enable PROM. CE8 enables the U40 which contains three I/O ports, PA, PB, and PC, and 256 bytes of RAM. This is the only RAM in the entire drive, and it is used for temporary buffers and "scratch pad" memory. CEA is used to enable U25, an 8254, a programmable interval timer. The Read and Write strobes are generated using the address lines A0 - A2 in conjunction with the RD and WR signals from the microprocessor.

4.3.3. Input Port

Signals from the interface are strobed into the Command latch by the GO signal. This is derived from the IGO received from the interface. All the signals received at the interface are terminated by a resistor network. There should only be one terminator, no matter how many drives are daisy chained together. The input signals are buffered before being latched into the eight way D-Flop U28. The clock for this device is GO. The GO signal is applied to the clock input of FF U43A.

If the formatter is selected (i.e., FAD, TAD0 and TAD1 match the address selected by Formatter Address jumpers W9 - W16), then the FSEL signal will be true. FSEL is clocked into U43A and will create the signal GOL. GOL is low true, and flags the microprocessor that a command is ready to be processed. The microprocessor will then enable the outputs of U28 and read the command. The toggling of the RDCO (read command) signal is also used to reset the command latch. The system is then ready to receive the next command while the microprocessor continues to process the previous command. If the drive does not respond at any commands, it is probably due to the Formatter Select.

4.3.4. IFEN (Formatter Enable)

IFEN is a signal which when low, enables the formatter. When IFEN transitions from high to low, the formatter is reset. The signal is inverted and passed to the microprocessor. It is used to clock FF U7A which generates an ABORT signal based on the condition of the FSEL signal. This is used to abort any runaway condition based on a requirement of the industry standard interface specification which defines that any runaway condition must be able to be stopped from the interface by pulsing IFEN. If an abort is necessary during a write operation, then the microprocessor will generate its own Last Word signal internally and execute a normal write terminate, plus a postamble. It would then be ready to write another block.

4.3.5. ENV (Envelope)

This signal is generated on the Read PCBA and is described elsewhere in this section. The signal is applied to the clock input of FF U7B; thus, a loss of envelope signal will toggle the FF and generate an EOR (end of record) signal. This signal will be cleared by the toggling of DBY. When the microprocessor is done writing, it will interrogate for either Envelope or end of record. If it finds neither, it will assume that no data was written, and will flash the 3200 LED to indicate a read after write fault.

4.3.6. TACH A & B

These are signals from the Switch PCBA. They are squarewave signals whose phase relationship to each another depends upon the direction of motion of the tape. The signals are connected to FF U43B which is configured as a quadrature detector. The output may be monitored at TP11, and will be low if the motion is forward, and high if the motion is reverse.

4.3.7. HIDEN (High Density)

This signal is used on the Read PCBA and is not usually at the interface.

4.3.8. IDBY (Data Busy)

This signal goes up and down for every data operation for both Read and Write. The signal is available at TP12.

4.3.9. IRDY (Ready)

This signal goes directly to the interface, and is not used internally within the drive.

4.3.10. IFPT (File Protect)

This signal goes directly to the interface.

4.3.11. ILPT (Load Point)

This signal goes directly to the interface.

4.3.12. IEOT (End of Tape)

This signal goes directly to the interface.

4.3.13. ISPEED (Speed)

This signal indicates that the tape is at the correct speed. It goes directly to the interface.

4.3.14. IFBY (Formatter Busy)

This signal can be set by either the microprocessor directly, or by the GO latch. This will compensate for any delay of the microprocessor in recognizing a command. This could be until the completion of the previous command.

4.3.15. IONL (On Line)

This signal goes directly to the interface and can be reset directly by a pulse on the RWU line. If the tape is not at BOT, then it will also preset flip-flop U16B and will issue a

rewind command. If the tape is at BOT, U16B cannot be preset, but the ONL FF U16A will be set. The microprocessor will interpret this as an Unload command and will unload the tape.

4.3.16. OLS (On Line Select)

This signal controls all the drivers on the Read PCBA to the host interface. By means of jumpers W5 or W6, the signal can also be used for the Status Enable. OLS indicates that the drive is selected by the formatter, online and not rewinding the tape.

4.3.17. D/A Converters

The two D/A converters, U12 and U13 produce a 0 to 10 volt signal at TP3 and TP2 respectively. These provide the supply and take up motor command voltages. 3.3 volts is equal to a 1 ampere command to the motors.

4.3.18. Peripheral Interface Chip (U40)

An 8155 PIC provides three I/O ports plus 256 bytes of RAM (Random Access Memory). The port output signals are primarily targeted to the write operations.

4.3.19. WRITE

This signal is used only by the Write Formatter to enable the formatter to write data.

4.3.20. WRTPWR/

This signal enables power to the write heads.

4.3.21. ERASE/

This signal indicates erase status which is connected to the interface on the Read PCBA.

4.3.22. ERASEPWR/

The Erase Power enable signal turns on power to the erase heads.

4.3.23. TLWD/

The Test Last Word signal provides an override for the generation of the internal Last Word operation in the event of a write abort. Last Word is asserted by the host during the writing of the last byte of data, and is clocked into the PIC by the IWRSTR. Recognition of this signal will initiate the generation of postamble.

4.3.24. WFMK/

Write File Mark is a control signal to the Write encoder chips U17, 18 and 19.

4.3.25. WIDENT/

Write Ident is a control signal to the Write encoder chips U17, 18 and 19.

4.3.26. IDENT

This is an interface signal indicating that a PE (phase encoded) tape has been detected.

4.3.27. TUMON/

This is a control signal used to enable the take up motor servo.

4.3.28. TUMCW

Take up motor clockwise control signal.

4.3.29. SPMON/

This is a control signal used to enable the supply motor servo.

4.3.30. SPMCW

Supply motor Clock Wise control signal.

4.3.31. CDBY -Cipher Data Busy

This signal is used on the Read PCBA and is the same as Data Busy except that during Search File Mark commands it will stay true for the entire command, whereas DBSY toggles with every block.

4.3.32. TUSEL

This is a signal for gating of RST 5.5. from the take-up Hall sensor.

4.3.33. SPSEL

This is a control signal for gating of RST 5.5. from the supply motor Hall sensor.

4.3.34. IDSEL

This is a control signal for gating of counter clock.

4.3.35. LOWRTH

Low read threshold is a control signal used on the Read PCBA to set the read threshold level.

4.3.36. READ

READ is a control signal sent to the Read PCBA.

4.3.37. FWD

Forward is used on the Read PCBA to determine tape direction.

4.3.38. LOADLED/

This is a buffered control signal for control of the Load LED on the Switch PCBA.

4.3.39. FPTLED/

This is a buffered control signal for control of the File protect LED on the Switch PCBA.

4.3.40. 3200LED/

This is a buffered control signal for control of the 3200 Bpi indicator on the Switch PCBA.

4.3.41. TIMER

The timer on the 8155 accepts the 16X clock as its input and generates the Ramp reset signal to the ramp generator on the servo control PCBA.

4.3.42. Counter Timer Chip

U25 is an 8254 programmable Counter Timer chip, comprised of three sixteen bit counters.

1. COUNTER 0 provides a microprocessor interrupt every other pulse of the Tach B signal. The Tach B signal is applied directly to the clock input of flip-flop U42A. The Q/ output is connected to the D input, thus creating a divide by two of the Tach B signal. When the Int 7.5 goes true, Q/ disables the gate to counter 0 and stops the counter. The microprocessor then reads the counter value and clears it. The next Tach B pulse will enable the counter again, permitting a new cycle. Thus, every other Tach B pulse is alternately a count cycle and a read cycle.
2. COUNTER 1 uses the constant 16X clock from the microprocessor and generates Int 6.5 to the microprocessor every sixteenth pulse. This 1X clock is used on the Read PCBA. Int 6.5 is always masked.
3. COUNTER 2 is used to measure the diameters of the reels and to record ID bursts at BOT. The functions are selected by the state of IDSEL.

4.3.43. Tape Reel Measurement

The Hall effect sensors TUS1 (take up sensor) and SPS1 (Supply sensor), are selected at gate U44A and U44B by the control signal from the 8155. The Hall sensors generate

a signal for every 90 degrees of rotation of either reel. This signal is gated to the clock of FF U42B which will enable the counter to be clocked by the TACHB signal. The counter will then record the number of tach pulses for 90 degrees of rotation of each tape reel in turn, and will be able to calculate the diameter of each spool respectively.

4.3.44. ID Burst Recognition

When IDSEL is true, then the clock input to the counter is provided by IDCLK. When the counter is enabled from FF U42B then the counter will record the transitions of IDCLK and permit recognition by the microprocessor.

4.3.45. Write Formatter

All of the circuitry for the write formatter is displayed on sheet two of schematic 500058. The write data, plus command signals from the user interface, are terminated on the PCBA by RN1 and RN2, and applied to the input of the receivers U1A, U1B, and U2A. The data is connected to the inputs of the three Write Encoder chips, U17, U18, and U19. These chips perform the phase encoding of the data and generate two outputs per channel, one high true and the other low true. These outputs go to individual open collector buffers feeding unequal resistors to drive either side of the nine channels of the write head.

4.3.45.1 Parity Generation

Each of the Write Encoder chips has an internal parity tree, providing three channel parity at pin 6 of the IC. The parity outputs of U18 and U19 are exclusive-or'ed together at U4D. The parity output of U17 is not used as the parity signal. The CH0 and CH5 signals are exclusive-or'ed together by U4B. The outputs of U4D and U4B are then exclusive-or'ed through U4C to create a parity signal at U4C pin 8. The parity output is connected to jumper W2. If this jumper is in place, then parity is generated internally, but if W3 is connected, the host must provide the parity.

4.3.45.2 Formatter Control

The write formatter is enabled when the WRITE signal is high. If TP13 is not high, there can be no writing of data. WFMK and WIDENT are normally high for writing. If WIDENT is low, requesting the writing of an ID burst, it will force U17 pin 19 low and disable U18 and U19 pin 8, thus disabling everything except the parity. In order to write a File Mark, WFMK is low, disabling channels 1,3, and 4. This forces the creation of a File Mark by erasing tracks 1,3 and 4, and writing 40 zeros on all other channels. Write control chip U20 counts the number of cells written. The ENA signal from U20 enables the Write encoder to write data to the heads. The SYNC command forces the writing of an all ones sync byte. The D/Z term is used to write preambles and postambles. The polarity of the PHASE input controls the polarity of the heads.

4.3.45.3 Timing

The timing of the write is controlled by U36 and U20. U36 generates timing based on the 16X clock into pin 8. The output is divided by two by FF U5B, generating the TOGGLE signal which defines the two phases of the write signal. The signal results in a square wave of 1F or 2F, where $2F = 80\text{KHz}$. U20 provides the master timing for the

writing of the 40 zero preamble and postamble, and continues to generate sync bytes to write data until LAST is set. The D/Z term is also and'ed with one of the decodes from U36 to create the write strobes (WSTR). WSTR can be monitored as a stream of evenly spaced pulses at TP14.

4.3.45.4 Last Word Generation

The LAST signal is generated either in response to ILWD from the user interface, or by the microprocessor in the form of TLWD/. These signals are or'ed at U21B, the output of which is gated at U8C with the HOLD signal. The output of U8C is applied to the D input of FF U5A. The output of U5A is the LAST signal and controls the writing of the Last word. The HOLD signal will not permit LAST to be set until after in data zone.

4.3.45.5 Write Power

One output from the write formatter provides power to the write head center tap, and another provides power to the erase head.

WRITE CENTER TAP goes to two pins on the write head which are tied in parallel, and provide the center tap for each of the write heads. The WRTPWR/ signal is inverted by U35C and wire-or'ed with the UNSAFE/ signal out of U35B. If UNSAFE/ is true, then neither write power nor erase power can be applied to the heads. When the input to U35A is high, the output is low, turning on transistor Q1. A Miller capacitor C6 across the collector/base junction slows the rise time in order to prevent writing unwanted transitions onto the tape.

R36 controls the current into the network. C15 is required to prevent oscillations, and the 10K resistor R38 is used to discharge C15 and to hold the base of Q2 off whenever Q1 is off. The two Zener diodes are required to change the center-tap voltages dependent on the recording density. They provide 10 volts at 1600 Bpi, and 7 volts at 3200 Bpi. These are selected by the HIDDEN signal enabling either VR2 a 12 volt zener, or VR1 a 7.5 volt zener. Q2 is a power emitter follower which drives the head center taps.

4.3.45.6 Erase

When ERASEPWR/ is true, and UNSAFE is false, Q3 is turned on. The collector of Q3 is connected directly through R44 and C10 to the Erase head. The RC network provides a time constant to the signal. If either write power or erase power is on, Q4 generates WRISON/. This signal is monitored by the microprocessor and anytime WRISON/ is true, the microprocessor will inhibit tape motion.

5. MAINTENANCE

5.1. ROUTINE PREVENTATIVE MAINTENANCE

The Qualstar Tape Drive has been designed to minimize the requirements for routine PM (preventive maintenance). If the directions for location and mounting of the drive have been followed, there should be no problems with air circulation through the drive. The ventilation openings on the drive should be inspected to ensure that no foreign object is impeding air flow through the unit.

The head and tape path components should be cleaned regularly to maintain maximum data integrity and reliability. The recommended period between cleaning should be eight operating hours or one week, whichever is less.

To clean the head, use a lint free cloth or cotton swab moistened with 91 percent isopropyl alcohol. Wipe the head carefully to remove all accumulated oxide and dirt. Do not use rough or abrasive cloths to clean the head. Only isopropyl alcohol or an approved head cleaning solution should be used; other solvents may damage the head lamination adhesive.

The tape guides, tape rollers and the tape cleaner should also be cleaned with a cloth or swab moistened with the head cleaning solution. Caution should be taken to ensure that no cleaning solution be spilled which might seep into and damage the tape guide bearings.

5.2. TROUBLESHOOTING AND FAULT ISOLATION

There are three primary types of failure that will be encountered in operating the Qualstar tape drive. These consist of:

- Power-on failures.
- Tape loading failures.
- Operational failures.

5.2.1. Power On Failures

These failures will usually occur when power is first applied to the drive. It is possible however, for the problem to occur during normal operation of the drive. There are three common indications that a Power fault has occurred:

- No indicators illuminated;
- All indicators flashing;
- All indicators dimly illuminated;
- Fan inoperative.

5.2.1.1 No Indicators Illuminated

This indicates a catastrophic failure that requires immediate removal of the AC power from the drive. Failure of the microprocessor or its ancillary circuitry would still result in at least one indicator being on, based on the design of the Interrupt structure of the drive. The following checks should be made before re-applying power to the drive:

Fuse

The fuse holder adjacent to the Power switch on the rear of the drive should be checked to verify the presence of a fuse. If a fuse is present, it should be tested to ensure continuity across the fuse. If the fuse is defective, it should be replaced and power re-applied to the drive. If the symptoms remain, further investigation is required to determine the cause of this problem.

Input Voltage

If the problem occurs upon initial application of power to the drive, the drive may not be properly configured for the AC input voltage. The drive should be disassembled and the settings of the power selection jumpers on TB-1 should be verified in accordance with the system interconnect diagram (DN 500030 in the Appendix). If the settings are incorrect, they should be changed appropriately.

Power Supply

It is possible that the power supply itself could have failed. In this case, it will be necessary to replace the Power Supply PCBA. Follow the steps as defined in Section 6 of this manual.

After the power supply has been replaced, apply power to the drive. The fan should run and the FPT indicator should illuminate. Measure the +5 volt supply on the Write/Controller PCBA with a VOM. Connect the probes between TP4 (+5V) and TP5 (GND). Adjust R24 on the Power PCBA for 5.00 volts ± 0.01 volt. This completes the replacement procedure for the Power PCBA.

5.2.1.2 All Indicators Flashing

This is commonly an indication that either the fan driver circuitry or the fan unit itself has failed. If the fan is running, check the following:

Power Supply

If the +5V supply is out of adjustment, it can result in all the indicators flashing. The +5 volt supply should be measured on the Write/Controller PCBA with a VOM. Connect the probes to TP4 (+5V) and TP5 (Gnd). If the supply is out of adjustment, then adjust R24 on the Power PCBA for 5.00 volts ± 0.01 volt.

5.2.1.3 All Indicators Dimly Illuminated

Fan Sense Circuit

The fan sense circuit consists of a resistor network and a comparator U5A (LM339) on the Power Supply PCBA. If this circuit fails, it will result in an erroneous fan failure indication. This symptom indicates that some form of load on the power supply is causing a reduction in the +5 volts. This load could be either internal or external.

Internal Short

Remove power and disconnect all external cabling from the drive. With the drive completely isolated, reapply power. If the indicators are still dim, there is probably an internal short loading down the power supply, or the supply itself has failed.

External Load

External shorts are usually due to installed interface cables. If all cabling is correct and the problem persists, then a short may exist in the host equipment. Disconnect the cables at the host end and restore power to the drive. If the fault indication is no longer present, the problem is in the host. If the problem persists, the cables themselves are probably defective. Remove the cables from the drive and restore power to the drive. If the problem is gone, the cables need to be tested for possible shorts. Correct any problems detected and resume operation of the drive.

5.2.1.4 Fan Inoperative

This can be caused either by a defective the fan or a defective -15V supply, which drives the fan.

Power Supply

The fan is powered by -15V DC (generated on the Power Supply PCBA by regulator chip U2). If no -15V is present, replace the Power Supply PCBA.

Fan

If the fan is not running, check the blades to ensure no mechanical interference exists. If the fan turns freely by hand, replace it.

5.2.2. Tape Loading Failures

Assume that power has been applied to the drive and the LOAD indicator is illuminated. A tape is mounted on the drive, and the LOAD switch has been pressed. Any one of the following symptoms may be observed:

- The tape motion continues beyond BOT;
- Fast rewind after BOT;
- Slow rewind after BOT;
- Tape motion is erratic.

5.2.2.1 Tape Motion Continues Beyond Bot

This problem is caused when the BOT marker is not detected by the drive. In order to troubleshoot the problem, open the drive to obtain access to the Switch PCBA. Connect a VOM between TP7 and ground on the Switch PCBA. With a tape mounted, and no EOT or BOT markers near the sensors, measure +4 volts $\pm 10\%$ with the VOM. Manually move the tape until the BOT marker is over the sensor. The voltage should switch to 1 volt $\pm 10\%$. When the tape is moved on, the voltage should return to the 4 volt level.

If these levels are correct, the problem is in the signal detection logic on the Write/Controller PCBA. If the levels are correct, with no marker over the sensors, the voltage between TP1 and ground 2.50 volts $\pm 10\%$. If out of tolerance, adjust R1 for 2.50 volts.

If this does not correct the problem, replace the sensor. This procedure is described in Section 6. See Section 7 for additional diagnostic procedures for the EOT/BOT sensing circuits.

5.2.2.2 Fast Rewind After Bot

The tape moves to BOT, stops, and the LOAD indicator illuminates. However, instead of remaining at BOT until commanded to move, the tape goes into a high speed rewind mode and is eventually "whipped" from the drive. This can be caused by either the drive not detecting the BOT tab, or by the drive mistaking the BOT marker for an EOT marker.

Non Detection Of Bot

If the drive does not detect BOT, the firmware permits the tape to proceed 25 feet before it decides that it is in the middle of a tape. It will then command a high speed rewind in order to search for BOT. This can be caused by either a missing or incorrectly positioned BOT marker or by a defective EOT/BOT sensor.

Bot Marker

The BOT marker should be placed on the tape within 25 feet of the physical beginning of the tape. Check the tape to ensure the presence and location of a BOT marker.

Bot Sensor

The BOT sensor function can be verified by manually moving the tape to a position where the BOT marker is physically over the sensor. If the BOT marker is sensed correctly, the LOAD indicator will flash rapidly. If the marker is incorrectly sensed as an EOT marker, then the 3200 indicator will flash rapidly. See Section 7 for additional details.

It is also possible that the EOT signal could be malfunctioning and causing the drive to function as though it were at the end of the tape. To verify that the EOT sensor is functioning correctly, connect the VOM between TP6 and ground Switch PCBA. With a tape mounted, and no EOT or BOT marker near the sensors, verify +4 volts $\pm 10\%$ with the VOM. Manually move the tape until the EOT marker is over the sensor. The voltage should switch to +1 volt $\pm 10\%$. When the tape is moved on, the voltage should return to the 4 volt level.

5.2.2.3 Slow Rewind After Bot

The tape proceeds logically to BOT, stops, and the LOAD indicator illuminates. However, instead of remaining at BOT until commanded to move, the tape slowly rewinds until it spools off the take up hub. This failure is caused by the drive detecting an Unload signal at the interface (IRWU is low). This can be the result of several conditions:

Coupler or Host Power Off

If power is removed from the coupler or the host, it will pull down the IRWU signal and cause the drive to sense a Rewind/Unload signal. If this is the case, re-apply power to the computer system, and reload the tape.

Power Cycled To The Computer

If power is applied to all units in the system, a power transient or momentary disruption at the host may cause a true signal to be latched into the drive, forcing recognition of a Rewind/Unload signal. Reloading the tape should rectify the problem.

Cables

The cables could be reversed or swapped. This problem is readily confirmed by removing all cables from the drive and reloading the tape. If the tape loads properly, reconnect each cable to the correct connector, being sure to observe the pin 1 orientation. If this does not rectify the problem, replace or repair the cables.

5.2.2.4 Erratic Tape Motion

If the tape motion becomes erratic, (i.e., the tape intermittently moves too fast, too slow, or irregularly), a problem is developing in the servo control loop which controls the tape motion.

The servo control loop is based on a tachometer sensor. The sensor is made up of a disk and a pair of optical sensors. By counting the pulses from the two sensors, the drive calculates the position and velocity of the tape. The two sensors are precisely located with a slight offset between them. By determining the phase relationship between the two pulse trains, the direction of motion of the tape is determined. The offset between the two sensors is a mechanical adjustment and is extremely critical.

It is possible that the relative positions of the sensors may have changed due to mechanical or thermal shock to the system.

Mechanical or electrical drift in the outputs from the sensors can be of such a magnitude that the discriminator will not be able to reliably determine the direction of the tape. This will result in irregular tape motion. If the error is of such a magnitude that the tachometer fails to properly count the pulses, then the system will lose track of position and velocity of the tape. This will cause the servo to overcompensate and cause further motion problems.

If the tachometer sensors are defective, or out of adjustment, follow the procedure outlined in Section 6. This repair and/or adjustment should be made by skilled personnel only.

5.2.3. Operational Failures

5.2.3.1 Slow Operation

If the drive has been operating correctly and then begins to take an undue amount of time to perform writes, reads, or both, the system may be experiencing an excessive amount of correctable data errors. If the errors occur during both read and write, then the problem is probably in the read circuitry. If the errors occur only while writing, the write circuitry is suspect. There are several possible causes for this error.

5.2.3.2 Dirt On The Head

The most common cause for data errors is a dirty head. Over a period of time, oxide particles accumulate on the head. The head should be periodically examined and cleaned to maintain maximum data integrity.

5.2.3.3 Bus Conflict

A component in one or more of the data channels may have degraded to the point of affecting data reliability. This kind of problem can be corrected by changing the Read PCBA or the Write PCBA.

5.2.3.4 Defective Media

Over extended periods of use, tapes will deteriorate to the extent that the data recorded on them can no longer be reliably recovered. Care should be taken not to use old or excessively worn media.

5.2.3.5 Worn Head

Though it is very unlikely, excessive data errors can be caused by a defective or excessively worn head. In this case, the head must be replaced. After replacement, a mechanical adjustment will be required to deskew the tape path and the read amplitudes will require adjustment. See Section 6 for detailed instructions.

5.2.3.6 Power Supply

The integral 5 volt regulator is a switching regulator. The switching circuit is dependent on a 100 uH coil (L1). The coil consists of wire wrapped on two cores with a precise air gap. The mechanical positioning of the coil could change either from thermal or mechanical shock, thus causing this circuit to start oscillating at a frequency between 30 and 40 Khz. This will inject noise into the system resulting in correctable errors. Correctable errors caused by power supply problems will be evident in both read and write operations. This problem calls for replacement of the power supply.

5.2.3.7 Motor Clamping

If either of the motors acts as though it is seizing up in one position, there is a problem in the servo loop associated with that motor. The drive uses brushless D.C. motors with Hall Effect sensors in the magnetic fields between the poles of the permanent magnets on the rotor. There are three Hall effect sensors in each motor. The signals from these sensors are transmitted over a ribbon cable to the servo circuitry on the Power PCBA. Any failure in either the Hall sensors, the cable, or the servo drivers can be determined by applying power to the system, and rotating the reel hub by hand. It will move freely up to a point and will then "seize" up.

For further discussion of operational errors, refer to Section 7.

5.3. GENERAL ADJUSTMENTS

There are several adjustments on the drive. The power supply adjustment has already been covered; the others are associated with read sensitivity, and data tracking.

5.3.1. Read Sensitivity

Generally, the read sensitivity does not require adjustment in the field. If the head is replaced, all read channel gains and sensitivities will need to be recalibrated. This procedure is given in Section 6.

5.3.2. Tracking Clock

An inability to consistently read data may be caused by a problem with the tracking clock. The data will read either intermittently or not read at all. In this case, the tracking clock will need to be readjusted. See Section 6 for details.

6. FRU REPLACEMENT INSTRUCTIONS

A Qualstar FRU (Field Replaceable Unit) is intended to be used as the preferred method of field repair. FRU's include major PCBAs and selected sub-assemblies. These replacement instructions include procedures for field replacement of FRUs.

Opening and closing the drive is always required. After that, select the necessary FRU procedure(s).

CAUTION

Always disconnect the power cord from the drive before removing or replacing any components.

6.1. OPENING AND CLOSING THE DRIVE

6.1.1. Opening the Drive

Place the drive on end with the push-button switches at the top. Remove the cable entry cover (two Phillips screws) and the interface cables. Remove the five screws holding the bottom chassis to the frame. These screws are located approximately 1/4" from the edges of the bottom chassis. Swing the chassis open. The Read/Formatter PCBA is on the left and the Write/Controller PCBA and Power PCBA are on the right.

6.1.2. Closing the Drive

After all maintenance procedures have been completed, verify that all PCBAs are securely fastened and that all DIP switches on the Write/Controller PCBA have been returned to their correct positions. Pull the large ribbon cable between the Read/Formatter and Write/Controller PCBAs towards you as you close the drive. Check all wires in the hinge area to be sure that none are trapped in the hinge as it closes.

Install the screws on the back chassis and replace the interface cables (J2 to the Read PCBA, J1 to the Write PCBA, pins 1 towards the bottom of the drive). Replace the cable entry cover and install the two cover retaining screws.

6.2. READ/FORMATTER PCBA REPLACEMENT

6.2.1. Read/Formatter Removal

The Read/Formatter PCBA is the large PCBA mounted directly to the base casting.

1. Disconnect the two power cables from J8B and J9B, the read head ribbon cable from J10, the read head ground wire from E1, and the control ribbon cable from J3B.

2. Remove the PCBA by removing six Phillips head screws from the four corners and two sides. The aluminum shield beneath the PCBA may drop as the last of the top four screws are removed.

6.2.2. Read/Formatter Reinstallation

1. Place the shield over the motor with the standoff side facing away from the base casting. The large clearance hole must be centered over the motor screw.
2. Route the head cable over the shield, making certain the cable does not cover any portion of the motor clearance hole. The cable will end up between the PCBA and the shield with its connector protruding above the top of the PCBA (note there is a 90 degree fold in the cable).
3. Place the Read/Formatter PCBA on the shield standoffs and install one of the long screws in the upper left corner and another in the right center hole (lower right corner of the shield).
4. Tighten these two screws. Manually spin the take up hub to verify nothing has come in contact with the motor. It should turn freely and quietly. If any rubbing is detected, remove the PCBA and correct the error.
5. Install the remaining four screws. The two short screws go to the bottom, directly into the casting bosses.
6. Fold the head cable over the top of the PCBA and plug it into J10. Install the black head ground wire onto terminal E1, making certain it is fully inserted.
7. Install the power cable onto J8B and the power cable from the Write PCBA onto J9B. These connectors are keyed. Plug the control cable onto J3B. Do not reconnect the interface cables J1 and J2 at this time.

6.2.3. Read/Formatter Adjustments

The following procedure sets the read channel gains to a preset level for maximum read data reliability.

6.2.3.1 Read Channel Gain Adjustment

There are nine identical channels of read electronics on the top half of the Read PCBA. They are identified from right to left as circuits 100 through 900, corresponding to data channel numbers: P,3,7,5,2,1,0,6,4. Two test points in each of the nine circuits are located in a horizontal row just above the write power connectors. They are labeled "1" and "2" with 1 being the upper test point. There is an analog ground test point AG2 adjacent to the power connector J9B.

1. Connect oscilloscope channel 1 to TP101 (channel P) with its ground lead (must have local ground lead) to AG2.
2. Connect the second channel to TP12 on the Write/Controller PCBA (left center of PCBA) and attach its ground lead to TP5.

3. Set the channel 1 gain to 1 Volt DC/division (including probe attenuation) and the channel 2 gain to 2 Volts DC/division.
4. Set the trigger to Normal (not Auto) on channel 2, DC-Positive. The time base should be set to 5 milliseconds/division. Set the channel 1 baseline to the center of the screen.

NOTE

A familiarity with the Diagnostic Mode section of this document is recommended before proceeding.

5. Set DIP Switches 1 and 2 on the Write/Controller PCBA to the ON (up) position. This will place the drive in the Diagnostic Mode of operation. Mount a working tape (will be over-written) on the drive.

NOTE

The type of tape will affect the read amplitude. Use the brand of tape most likely to be used on your drive. Qualstar uses Scotch 700 to set the gains at the factory.

6. Apply power and press the LOAD switch, the tape should run forward. Let it run past the BOT tab, then press the FPT switch (motion should stop).

It should be noted that in the diagnostic mode (Test 4), the LOAD switch causes the drive to write in the forward direction. The FPT switch stops motion and toggles the data density when the drive is at rest. The 3200 switch causes the drive to read in the reverse direction. The 3200 indicator illuminates when the 3200 Bpi data density is selected by the FPT switch. Make certain the 3200 indicator is off.

7. Press the LOAD switch. The drive will now run forward and simultaneously write and read data blocks of all zeroes data approximately 2K long. It will continue writing until the FPT switch is pressed or until the EOT tab is encountered, whereupon it will begin reading in reverse.
8. Adjust the scope trigger level to start on the rising edge of the channel 2 signal.
9. Adjust the trimpot R104 (R4 in circuit 100, Channel P) for 2.0 volts zero-to-positive peak (not peak-to-peak) at TP101. Make certain the probe lead is not touching the adjacent test point, as this will cause erroneous readings.
10. Move the channel 1 probe to TP201 and adjust trimpot R204 for the same reading. Repeat this procedure for the remaining 7 circuits. There should be no more than 0.25 volt of amplitude modulation on the read envelope (due to tape irregularities). Excess amplitude modulation indicates worn tape, a dirty or defective head, poor tape tracking, or excessive tape guide runout.

6.2.3.2 Tracking Oscillator Center Frequency Adjustment

1. Connect the channel 1 probe to TP5 located at the lower left corner of the Read PCBA.
2. Increase the scope gain to 200 millivolts/division.

3. Adjust R28 so the transition from the free-running state to the locked state is of equal amplitude. This occurs approximately 5 milliseconds (1 division) after the beginning of the sweep. This adjustment should already be very close and require little change. If two different levels between data blocks are seen, continue writing for a minute, then stop the tape using the FPT switch and start reading in reverse using the 3200 switch. This should eliminate the second level which is an artifact of the write/read crosstalk (and which does not adversely affect read data reliability).
4. Stop the tape using the FPT switch.
5. Turn S1 and S2 to the OFF (down) positions.
6. Rewind the tape using the LOAD switch. The drive will now rewind the tape to BOT.
7. Unload the tape using the LOAD switch to unload the tape. Remove the scope probes.

6.3. WRITE/CONTROLLER PCBA REPLACEMENT

6.3.1. Write/Controller Removal

The Write/Controller PCBA is the large PCBA on the power supply chassis.

1. Remove the three ribbon cables attached to the PCBA at J3A, J4 and J5.
2. Remove the write head cable at J6A (this will also require removal of the two cable ties on the bottom of the PCBA).
3. Remove the six screws holding the PCBA to the standoffs and remove the PCBA.
4. Remove the power cable on the rear side of the PCBA at J8A.

6.3.2. Write/Controller Reinstallation

1. Verify that all the jumper plugs on the new PCBA are set to the same positions as those on the PCBA removed. The 8 DIP switches should be off.
2. The firmware contained in the PROM at U39 must be the latest version. If the replacement PCBA has a lower version number (older), the PROM from the removed PCBA should then be installed into the replacement PCBA.
3. Install the power cable on the back side of the new PCBA at J8A.
4. Install the PCBA and secure with the six screws.
5. Replace the four cables and two tie wraps removed above.

NOTE

Pin 1 goes to the bottom of the PCBA (near U38 or C35).

6.3.3. Write/Controller Adjustments

No adjustments are required after replacement of the Write/Controller PCBA.

6.4. POWER SUPPLY PCBA REPLACEMENT

6.4.1. Power Supply Removal

Remove the Write/Controller PCBA as previously described. Remove the wires and cables described in Table 6-1 on page 6-5.

CONNECTOR	CABLE/WIRE-COLOR	DESTINATION
E1	Orange	Power Transformer
E3	Red	Power Transformer
E4	Black	Power Transformer
E5	Violet	Power Transformer
E7	Yellow	Power Transformer
E8	White	Power Transformer
E9	Black (or Blue)	Fan
E10	Red	Fan
E11	Red	Supply Motor
E12	Brown	Supply Motor
E13	Orange	Supply Motor
E14	Red	Take Up Motor
E15	Brown	Take Up Motor
E16	Orange	Take Up Motor
E17	Green	Chassis Ground (see warning below)
E18	Red	Second Fan on 1053/4 only
E19	Black (or Blue)	Second Fan on 1053/4 only
J9A	White Cable	Read PCBA Power
J12	Ribbon Cable	Motor Hall Sensor PCBA
J4B	Ribbon Cable	Write/Controller PCBA

Table 6-1. Wiring and Cables

WARNING

The green wire connects to E17 only. If the terminal is connected to TP2 which is adjacent to E17, severe damage can result if power is applied.

Remove the four mounting screws (from the bottom of the chassis) with a Phillips screwdriver. This may require holding the hexagonal standoffs to prevent their turning.

6.4.2. Power Supply Reinstallation

1. Check to be sure that the replacement board has the same part number as the one just removed. Three versions of this board are used in different model transports. See the FRU spare parts list for correct numbers.
2. Install the new board with the four screws and standoffs. Be careful not to pinch the primary power leads from the power transformer.
3. Reinstall the wires and cables as indicated in the above table.
4. Replace the Write/Controller PCBA as previously described.

6.4.3. Power Supply Adjustments

1. Apply power. The fan should run and the FPT indicator should illuminate.
2. Connect a VOM between TP4 (+ 5 Volts) and TP5 (GND) on the Write/Controller PCBA.
3. Adjust R24 on the Power PCBA for 5.0 Volts ± 0.01 Volt.

6.5. SWITCH PCBA REPLACEMENT

6.5.1. Switch Board Removal

The Switch PCBA is mounted to the base casting and contains the three push-button switches and signal conditioning electronics for the optical sensors (Tachometer and EOT/BOT).

1. Remove the Read/Formatter PCBA as described previously.
2. Remove the two cables at J16 and P5.
3. Remove the three screws holding the board to the casting and remove the board.

6.5.2. Switch Board Reinstallation

Replace the board and secure it with the three screws and the two cables.

NOTE

The connector at J16 has only 12 of 16 possible pins. The colored wire in the corner of the connector goes to pin 1 (lower left corner).
--

6.5.3. Switch Board Adjustments

Adjust the tachometer gain and phasing and EOT/BOT balance per Section 6.

6.6. EOT/BOT SENSOR ASSEMBLY REPLACEMENT

6.6.1. EOT/BOT Sensor Removal

1. Remove the 4-wire cable from the EOT/BOT circuit PCBA.
2. Remove the two Phillips screws and lift the assembly out from the front of the drive.

6.6.2. EOT/BOT Sensor Reinstallation

Install the new assembly with the two screws and reinstall the 4-wire cable.

NOTE

The colored wire goes nearest to the casting.

6.6.3. EOT/BOT Sensor Adjustments

Adjust EOT/BOT balance per Section 6.7.4.

6.7. TACHOMETER SENSOR REPLACEMENT

6.7.1. Tachometer Sensor Removal

CAUTION

Both tape guide rollers are precisely centered in their bearings at the factory for minimum radial runout. The screws on the back of these shafts are securely locked after this adjustment. Do not loosen the screws (on the tape guide roller shafts) as it will upset this adjustment.

There are two Tachometer Sensors (optical switches) mounted on either side of the slotted Tachometer Disk. The one on the left of the disk is referred to as TACHB, and the one on the right is TACHA.

1. Remove the connector from the optical switch to be replaced.
2. Remove the two mounting screws with a 3/32 inch Hex Ball Driver being extremely careful not to dent or bend the delicate tachometer disk.

6.7.2. Tachometer Sensor Reinstallation

1. Replace the sensor and install the two screws and washers and tighten them until they just begin to clamp the optical switch housing.
2. Reinstall the connector with the colored wire(s) nearest the casting.

6.7.3. Tachometer Sensor Gain Adjustment

1. Connect the oscilloscope probe to TP5 on the Switch PCBA, and connect the ground lead to the test point marked "G".
2. Set the oscilloscope to 2 volts DC/Div and 20 microseconds/Div.
3. Manually spin the top Tape Guide Roller and observe the approximate duty cycle of the waveform at TP5.
4. Adjust R3 for 50% duty cycle (a symmetrical square wave).
5. Set DIP Switch 1 on the Write/Controller PCBA to the ON position.
6. Load a scratch tape and press the LOAD switch to start the tape running forward at 50 IPS.
7. Readjust R3 for a 50% duty cycle or a width of 100 microseconds ± 5 microseconds.
8. Connect the oscilloscope probe to TP4.
9. Adjust R2 for 50% duty cycle or a width of 100 microseconds ± 5 microseconds.
10. Stop the tape by pressing the FPT switch.

6.7.3.1 TACHOMETER SENSOR Phasing Adjustment

The two optical switches must be mechanically aligned so that their signals will be in quadrature (90 degrees apart). The TACHB signal is used to determine tape velocity, while the phase relationship between TACHA and TACHB signals (positive or negative quadrature) determines the direction of actual tape motion.

1. Set both oscilloscope channels to 2 V/cm and the time base to 20 microseconds/cm.
2. Connect the ground lead to the test point on the Switch PCBA marked "G".
3. Connect channel 1 to TP4 and channel 2 to TP5.
4. Trigger on the rising edge of channel 1.
5. Firmly tighten the screws on the TACHB sensor (left of tachometer disk) and loosen the screws on the TACHA sensor (right of tachometer disk).
6. Start the tape moving by pressing the LOAD switch (DIP Switch 1 must be on).
7. Move the TACHA sensor until the channel 2 signal (TP5) falls 90 degrees (50 microseconds) after the rise of the channel 1 signal (TP4).
8. Tighten the screws on the sensor and verify the falling edge of channel 2 is within 10 degrees (5.6 microseconds) of the desired 90 degrees (50 microseconds) lag from the rising edge of channel 1 (TP4).
9. Repeat the procedure until the phasing is within tolerance. Verify correct quadrature by checking for a low logic signal on TP11 of the Write/Controller PCBA (located beneath the DIP Switches). The signal should be high for reverse tape motion.

10. Stop the tape by pressing the FPT switch.
11. Turn DIP switches S1 through S4 off to exit the diagnostic mode.
12. Rewind and unload the tape by pressing the LOAD switch once, and again after the tape has reached BOT.

6.7.4. EOT/BOT Balance Adjustment

1. Load a tape and press the LOAD switch to apply tension.
2. Connect a VOM between TP1 and "G" on the Switch PCBA.
3. With neither the EOT or BOT reflective strips under the EOT/BOT sensor assembly, adjust R1 for 2.5 volts.

6.8. REEL MOTOR REPLACEMENT

6.8.1. Reel Motor Removal

1. Remove the Read/Formatter PCBA.
2. Grasp the supply or take up hub and loosen the #10 screw in the center of the motor shaft.
3. Remove this screw and the motor rotor. The motor armature can now be replaced by removing the two screws at the motor pilot hole.

6.8.2. Reel Motor Reinstallation

Reassemble in the reverse order. Be sure to apply sufficient torque to the motor screw to prevent slippage.

6.9. HALL SWITCH PCBA REPLACEMENT

6.9.1. Hall Switch Removal

1. Remove both motors as previously described.
2. Remove the four screws which hold the Hall PCBA to the base casting.

6.9.2. Hall Switch Reinstallation

Install the replacement Hall Switch PCBA in the reverse order.

6.10. HEAD REPLACEMENT

6.10.1. Head Removal

1. Note the position of all three cables and the manufacturer's name on the head. These cables are specific for each type of head. Do not replace a Hamilton with a Nortronic or vice versa.
2. Remove the head cover and unplug connectors at the rear of the head.
3. Using a 3/32 hex driver, loosen the two head retaining screws (4-40 x 11/16) with one hand and carefully remove the head with the other hand. Save the head shim for reinstallation.

NOTE

The head shim is a .005" thick mylar shim installed between the head and the base casting. This shim must be used as it is required to maintain the electrical isolation of the head and proper head spacing above the casting surface.

6.10.2. Head Reinstallation

1. Install the appropriate replacement head and head shim in the reverse order.
2. Before tightening the screws completely, adjust the head such that it is centered within its rotational play range. When properly located, the head is at a 85.0 ± 0.5 degree angle with the tape drive housing. Use a protractor to orient the head and secure screws.
3. Do not over tighten.
4. Reinstall read, write, and the erase head connector(s) in the original positions. Be sure that the red wire on write cable is towards the drive and the blue wire of the erase head connector(s) is towards the drive.

NOTE

Once a head has been replaced, the read amplitude, tracking oscillator, and skew must be adjusted.

6.10.3. Adjustment Of Read Amplitudes

1. Load the drive with tape, but do not press the LOAD switch at this time.

CAUTION

This procedure will destroy any information on the tape.

2. Set oscilloscope settings for dual trace/DC, display = chop, channel 1 = 100mv/Div (with 10:1 probe), channel 2 = 50mv/Div (with 10:1 probe), and time /division control to 5msec/Div.

3. Connect channel 2 of scope to read board TP-10 (or TP-5 for drives configured at level 8 or lower) and analog ground. Connect channel 1 of scope to channel P (TP-01) of read board and analog ground.
4. Set the switches on the write board S1 and S2 to the on position.
5. Start the tape reading forward at 1600 Bpi by pressing the LOAD switch once.
6. Stop the tape by pressing the FPT switch once.
7. Write and read at 1600 Bpi by pressing the LOAD switch again.
8. A block of data should be seen on the oscilloscope. Adjust the trigger level on the scope to lock in one block.
9. Adjust RX04 of channel P to 2.00 volts peak (4.00 volt peak to peak).
10. Repeat for all channels (P thru 4).

NOTE

Whenever the read gains are adjusted, the adjustment of the tracking oscillator should be checked.

6.10.4. Verification of 3200 Bpi Amplitudes

NOTE

The following steps may be skipped for drives with only 1600 Bpi capability.

11. After adjusting all the channels up to channel 4, stop the tape by pressing the FPT switch once.
12. After the tape has come to a complete stop, press the FPT switch once more.
13. Press the LOAD switch to start drive writing and reading at 3200 Bpi.
14. Change the setting of channel-1 of the scope to 50mvolts/Div.
15. Check all the channels on the Read board. The head output signal should now read between 0.52v and 0.82v peak.

NOTE

Do not readjust the trimpots on the read board, unless the primary mode of operation is to be at 3200 Bpi.

Once the drive has passed all the adjustments press the FPT switch once, then turn both S1 and S2 of the write board off, and press the LOAD switch once. This will rewind the tape to BOT. Unload and remove the tape.

6.10.5. Write Head Skew Adjustment

Write head skew is observed by connecting the write head to the read circuitry and reading a standard skew tape, and is adjusted by adding or removing shims under the tape reference guides.

1. Turn the drive power off, disconnect the read cable from the Read board (J10), and disconnect the write cable and erase connector(s) from the head.
2. Install a special skew cable from the Read board (J10) to the write head, and connect the red wire to ground. The special skew cable is available from Qualstar as P/N 500260-01-3.
3. Connect scope channel 1 to channel 4 of TP1 on the Read board and scope channel 2 to channel 5 of TP1.
4. Channels 4 and 5 represent the outside edge tracks on the tape. Set both channels to 50 millivolts/Div, and set both channels in the center of the display.
5. Set the Time/Div to 5 usec/Div.
6. Turn S1 on the Write board on and mount the skew tape.
7. Turn the drive on and begin reading the skew tape at 1600 Bpi by pressing the LOAD switch once.
8. Observe the two waveforms on the scope. If the skew is in specification, they will be in phase with each other. They can lead or lag each other up to 5 microseconds before adjustment is required.
9. If adjustment is necessary, stop the tape and remove one of the guides by loosening it with an allen wrench while holding the nut that is located behind it inside the drive.
10. Carefully unscrew the guide and remove it, being sure not to drop the guide or guide spring. Do not allow the nut to fall inside the drive, as it may be attracted to and stick to one of the magnets in the motors.
11. If channel 4 leads channel 5, add shims to the upper guide, or remove shims from the lower guide. If channel 5 leads channel 4, add shims to the lower guide, or remove shims from the upper guide.
12. Add or remove shims until both sine waves on the scope are in phase within 5 microseconds.

NOTE

The individual shims may be .001 or .004 inch thick, and any combination may be used to achieve proper alignment. However, the total thickness of shims under each tape guide must be at least .002 inch and must not exceed .006 inch.

13. Reinstall the guide by mounting it back on the base casting and reinstalling the nut, being careful not to pinch any wires. Do not overtighten the screw.
14. With the scope probe, check to see that the rest of the channels are also within the 5 microsecond limit with respect to channel 4.
15. Once the skew is adjusted, press the FPT switch to stop the tape.

16. Press the 3200 switch to rewind the tape. The tape will not stop at BOT, so turn the power off and unload the tape manually. Do not rewind the skew tape at high speed, as this will shorten its life.
17. Turn S1 off. Remove the skew cable, reconnect the read cable to the read board (J10), and the erase connector(s) and the write cable to the head. Remove the scope probes.
18. Replace the head cover, close the chassis assembly, reconnect the drive to the computer and test to see that it works properly.

6.11. TAPE GUIDES

6.11.1. Tape Guide Removal

NOTE

Both tape guide rollers are precisely centered in their bearings at the factory for minimum radial runout. The screws on the back of these shafts are securely locked after this adjustment. Once the locking screw has been loosened, mechanical adjustment will be required to restore the radial runout to 0.0005 inches maximum.

1. Open tape drive to expose the back side of the tape guide assemblies.
 2. Determine which roller is to be replaced.
- A full set of replacement parts should be available before disassembly. The top tape guide assembly includes additional parts required for the tachometer. Both guides are housed in sets of bearings that are retained in place with Loctite.
3. In order to replace either tape guide, remove the attachment screw located on the back of the roller shaft.
 4. Restrain the tape guide end with hand pressure, while turning the other end with a 3/32 hex driver.
 5. Note the location of internally assembled parts during removal of roller shaft. The parts required for the bottom shaft assembly are: one tape guide, one spring, one large spacer, two spring spacers, one washer and one retaining screw. The top roller assembly is similar, but includes one smaller spacer, one spring spacer, one tach disk and two disk clamps.

If the tape guide can not be adjusted within tolerance, or if excessive noise persists, then the guide bearings must be replaced also. In order to remove these bearings, force must be applied to break the Loctite adhesive. A small hammer and a knockout punch applied in the direction of the center of rotation will provide sufficient force to loosen the bearings.

CAUTION

Do not allow the bearing to cock in the hole. The steel bearing housings are much harder than the aluminum and may damage the inside diameter of the bored hole.

After removing the bearings, the machined surfaces which locate the bearing must be cleaned of Loctite residue and sized prior to reinstallation. This normally is accomplished with light rotational pressure using a bearing scraper. Use care to prevent the removal of any base metal from the bore.

6.11.2. Tape Guide Reinstallation

1. Before reinstalling roller shafts, it may be necessary to replace the roller bearings. Roller bearings must be located properly and installed with an axial preload. In order for this to be accomplished, the machined surfaces which contact the bearing must be clean and the inside diameter must allow a slip fit of the inside bearing during installation. Check that these conditions are met and correct if necessary.
2. Prepare the outside bearing by cleaning and applying a small amount of Loctite adhesive to the outside diameter of the bearing. No more than three spots located 120 degrees apart are recommended. Excess adhesive may leak into the bearing race and damage performance.
3. Insert the bearing squarely against the flat machined casting surface using hand pressure. Do not force the bearing with use of tools.
4. Allow adhesive to set for 30 minutes before starting tape guide assembly.
5. Gather parts to complete the final installation of the tape guide assembly. Refer to notes during removal for list and location of parts depending on top or lower tape guide. If inside roller bearing is being reinstalled at this point, the outside bearing surface must be prepared in the same manner as the outside bearing described earlier in this section.
6. Insert the tape guide shaft through outside bearing to full depth.
7. Lightly coat the outside diameter of the bearing with Loctite.
8. Reinstall the parts in the reverse order of removal. The inside roller bearing is installed after spring and spring spacers, but before the tach parts (top tape guide), flat washer and retaining screw.
9. After securing screw for the first time, check that inside bearing is free to move along shaft against and return under spring pressure. This assures a good preload on the bearing.
10. In order to assure that all components are stacked securely square, loosen the screw about a quarter turn and then retighten it. Repeat this process (10) times in rapid fashion before adhesive is allowed to set.

6.11.3. Tape Guide Adjustments

Use a 0.0001" dial indicator set to zero to adjust roller runout to within 0.0005".

This adjustment normally takes more than one iteration of the following:

1. Loosen screw slightly providing some tension in the tape guide assembly.
2. Rotate roller shaft to indicate runout.

3. Apply small amount of hand pressure in line with the maximum reading.
4. Repeat the two previous steps until desired tolerance is achieved.

If all attempts fail, remove roller shaft and rotate 90 degrees relative to bearings and reinstall shaft assembly. Then repeat adjustment procedure.

7. DIAGNOSTICS

All Qualstar Tape Drives have a set of diagnostic modes built into the microprocessor control firmware. The first two of these functions are available without having to open the drive. The remaining functions require opening the drive and setting one or more of DIP Switches (S1 through S4 on the Write/Controller PCBA).

7.1. EOT/BOT SENSOR CHECK FUNCTION

The first diagnostic function displays the state of the EOT/BOT sensor circuits. This is automatically enabled whenever the drive is in its standby state (tape has not been tensioned). This standby state exists when the drive is first powered up or whenever a tape is unloaded. When in the standby state, the LOAD indicator will rapidly flash whenever the BOT sensor output is true, and the 3200 indicator will rapidly flash whenever the EOT sensor output is true.

The circuits can be tested by threading a tape with both a BOT and EOT tab on the leader and manually positioning each tab in front of the BOT/EOT sensor assembly. The LOAD or 3200 indicators should rapidly flash when the appropriate tab is in front of the sensor. This indicates proper operation of the EOT/BOT sensors and circuits.

7.2. TAPE MOTION EXERCISE FUNCTION

The second diagnostic function exercises tape motion indefinitely. It is invoked only when the drive is in the standby state. The standby state is indicated by illumination of the FPT indicator only. The drive enters the standby state after power is applied and when a tape is unloaded. To invoke the tape motion exercise function:

1. Thread a tape.
2. Hold the FPT and 3200 switches pressed.
3. Press the LOAD switch.

The tape will load and then proceed to "shoe-shine" to the EOT tab, rewind to the BOT tab, and repeat the sequence indefinitely. The process may be terminated by holding the LOAD switch pressed until the drive begins a rewind cycle. It will then rewind to the BOT tab and become ready for normal operation.

This function also checks the forward and reverse start distances. It will illuminate the LOAD indicator if the drive ever exceeded the allowable forward start distance and the 3200 indicator if it ever exceeded the reverse allowable start distance. It can therefore be concluded that a properly operating drive should run indefinitely without either of LOAD or 3200 indicators ever illuminating. The FPT indicator will remain illuminated for the duration of the test.

It should be noted that this test only exercises tape motion. It does not write on the tape and it does not check any of the data electronics.

7.3. BUILT-IN SERVICE DIAGNOSTIC AIDS

There is a series of built-in service diagnostic aids which can be used to check the motion and data transfer electronics. The drive must be opened to gain access to the DIP Switches, on the Write/Controller PCBA, which control these functions. The first four DIP Switches (S1 through S4) control all the diagnostic aid functions. All four of these switches must be in the off position (down) to restore normal drive operation. S1 selects the diagnostic mode, and S2, S3 and S4 select specific diagnostic functions.

The diagnostic mode can be entered from either the standby state (tape is not tensioned) or from any error condition state (one or more flashing LEDs). To initiate the diagnostic mode:

1. Set S1 on.
2. Thread a tape.
3. Press the LOAD switch.

The tape will begin reading forward. This will continue until the EOT tab is reached whereupon it will commence reading in the reverse direction. The diagnostic mode is now set.

In several of the diagnostic tests the tape motion is controlled by the three front panel switches. They function in the following manner:

- LOAD Initiates forward reading or writing
- FPT Stops all tape motion, toggles the data density (tape speed) when the tape is stopped
- 3200 Initiates reverse reading

The LOAD and FPT indicators should not illuminate in the diagnostic mode except when an error condition occurs. Error conditions are indicated by one or more flashing LEDs. The 3200 indicator illuminates when 3200 Bpi is selected (25 ips) and is off for 1600 Bpi (50 ips).

To terminate the diagnostic mode, turn S1 through S4 off. Press the LOAD switch. The tape will rewind to the load point. Press LOAD again to unload the tape.

7.4. DIAGNOSTIC TESTS

Table 7-1 summarizes the diagnostic tests available:

TEST	S1	S2	S3	S4	TEST FUNCTION
0	ON	off	off	off	Read Mode (Fwd/Stop/Rev)
1	ON	off	off	ON	Read Mode (Fwd/Stop/Rev)(duplication of test 0)
2	ON	off	ON	off	Motor Calibration Test
3	ON	off	ON	ON	Motor Amplifier Linearity Ramp Check
4	ON	ON	off	off	Write approximately 2K records (data = IWDn lines)
5	ON	ON	off	ON	Write Filemarks
6	ON	ON	ON	off	Write/Erase Power Timing Cycle Test (no motion)
7	ON	ON	ON	ON	Write/Erase Power Timing Cycle Test (no motion-duplication of test 6)

Table 7-1. Diagnostic Test Switch Settings

7.4.1. Tests 0 & 1

The read mode allows one to read forward or reverse at 1600 or 3200 Bpi. All Read Formatter signals operate as though a normal read operation were being performed via the interface. The DBY signal (Write/Controller PCBA TP12) goes true before each data block and pulses low for 0.3 inches after each data block read. Tape motion reverses at the EOT and BOT tabs. Press the FPT switch to stop the test.

7.4.2. Test 2

This mode is used at the factory to verify motor torque output. When the LOAD switch is pressed, 1 ampere of current is supplied to the takeup motor. Pressing the FPT switch stops either motor. When the 3200 switch is pressed, 1 ampere of current is supplied to the supply motor.

7.4.3. Test 3

This mode ramps the current on the selected motor from 0 to full scale. The LOAD switch selects the takeup motor and the 3200 switch selects the supply motor. The FPT

switch turns off both motors. The appropriate motor current can be observed with an oscilloscope on the power PCBA test points. TP1 for the supply motor, TP2 for the takeup motor. The voltage at these two test points is equal to -3.33 volts per ampere of motor current.

7.4.4. Test 4

This write test is used to calibrate the read amplifier gains and set the tracking oscillator center frequency. Refer to the "Read/Formatter FRU Procedure" in Section 6 of the manual. The drive will start reading in reverse when the EOT tab is encountered and will continue until it reaches the BOT tab, whereupon it will stop. It should be noted that the drive will not write if the diagnostic mode is entered with S1 and S2 on. First stop the reading (press FPT switch) before initiating writing with the LOAD switch. Writing takes place only in the forward direction.

7.4.5. Test 5

The Filemark test writes standard filemarks until the EOT tab is encountered whereupon it will begin reading in reverse until stopping at the BOT tab. This test can be used to verify write and read channel operation but is not used for calibration purposes.

7.4.6. Tests 6 & 7

The Write/Erase Power Timing Cycle test continuously cycles write and read power for verification of the circuits. The write voltage is selected by the data density and is visible on W8 on the Write/Controller PCBA. The erase power is to be found on W7 (adjacent to W8).

7.5. ERROR INDICATIONS

Operating error conditions can arise from three possible sources: operator error, controller error, and drive faults. The tape drive detects these errors and stops operation until they are corrected (if possible) or acknowledged by the operator. All error conditions are indicated by a combination of one or more flashing indicators. Table 2-3 summarizes the error conditions. Following the table, each error condition and possible remedies are described in detail.

The following is a list of error and fault conditions and possible remedies:

7.5.1. Load Error

- **Indicated By:** flashing LOAD indicator
- **Caused By:** excessive tape slack, improper threading or failure to properly clamp the tape reel.
- **Corrective Action:** correct the situation and press the LOAD switch for 1 second to resume the load sequence.

7.5.2. File Protect Error

- **Indicated By:** flashing FPT indicator
- **Caused By:** the controller attempting to write on a file protected tape.
- **Corrective Action:** correct problem with control program if any, then press FPT switch for 1 second to resume operation.

7.5.3. Read After Write Fault

- **Indicated By:** flashing 3200 indicator.
- **Caused By:** failure to read the data being written. This could occur if the tape is incorrectly threaded or by an internal drive error.
- **Corrective Action:** press the 3200 switch to resume operation. The last data written will not be recoverable. There will probably be some operator action required to inform the program of this condition.

7.5.4. Start/Position Fault

- **Indicated By:** flashing LOAD & FPT indicators
- **Caused By:** failure to reach operating speed within a specified time or inability to properly position the tape for a read or write operation. This can be caused by improper threading, excessively low primary line voltage or an internal drive fault.
- **Corrective Action:** press the LOAD switch to return to the pre-loaded state. Then perform a load operation. If the tape is past the load point, it will automatically reverse and return to the load point. If this fault remains, check the primary line voltage.

7.5.5. Write/Erase Power On Fault

- **Indicated By:** flashing LOAD & 3200 indicators
- **Caused By:** Write or Erase power detected when it should be off. This is an internal drive fault.
- **Corrective Action:** press the LOAD switch for 1 second to initiate an unload sequence. Reset the power and retry to operate the drive. If the fault remains, the drive will require servicing.

7.5.6. Write/Erase Power Failure/fault

- **Indicated By:** flashing LOAD or FPT & 3200 indicators
- **Caused By:** failure of Write or Erase power to energize during a write operation. This is an internal drive fault.
- **Corrective Action:** press the LOAD switch for 1 second to initiate an unload sequence. Reset the power and retry to operate the drive. If the fault remains, the drive will require servicing.

7.5.7. Motion Fault

- **Indicated By:** alternately flashing LOAD & FPT indicators
- **Caused By:** tape running off the end of the reel or by an internal drive fault. Running off the end of the reel can be attributed to one of three possible causes; controller failure to recognize End-of-Tape signal, missing End-of-Tape tab on tape, or failure of the drive to sense the EOT tab.
- **Corrective Action:** press the LOAD switch to return to the pre-loaded state. Then perform a load operation. If the tape is past BOT, it will automatically reverse and return to BOT.

If the end of the tape has come off the supply reel, moisten the end and lay it over the top of the reel. Then turn the reel counter-clockwise so that the tape winds onto the reel. Continue winding the tape onto the reel for five feet past the reflective EOT (end-of-tape) marker. Press the LOAD switch for one second to initiate the load sequence. The tape will load, then rewind to the load point.

7.5.8. Fan Failure Fault

- **Indicated By:** flashing LOAD & FPT & 3200 indicators
- **Caused By:** failure of cooling fan.
- **Corrective Action:** press the LOAD switch for 1 second to initiate an unload sequence. Reset the power and retry to operate the drive. If the fault remains, the drive will require servicing. Do not leave the power on if this fault persists as overheating may result.

APPENDIX A: GLOSSARY OF TERMS

Various terminology has evolved in the industry, much of which consists of synonyms. The industry at times misused some terms which has led to confusion. To avoid further confusion, selected terms are defined in this appendix. The terminology definitions which follow are for the purpose of this document only.

BOT

Synonymous with the term "Load Point", Beginning of Tape defines the point at which data begins on the tape. It is indicated by the reflective BOT marker (BOT Tab) which is placed along the reference edge of the tape (nearest the label on the reel), on the uncoated side, 16 feet from the physical beginning of the tape.

CHARACTER

Nine data bits written in parallel from one edge of the tape to the other. This consists of 8 data bits (a byte) and an odd-parity bit. Record or Block - a group of data characters recorded on the tape. The number of characters in a record is determined by the user. A record is the minimum amount of data that can be written or read by the drive.

COUPLER

A hardware device, usually packaged as a circuit PCBA assembly, which is required to interface a peripheral to a particular type of host computer. This device has also been called a host interface adapter or host adapter. Some industry literature has (somewhat incorrectly) referred to the coupler as a controller.

Since tape drives containing built-in formatters have the majority of the controller function resident within the drive, the use of the term controller is somewhat of a misnomer.

The coupler typically contains all of the circuitry necessary to convert the signals of the formatted tape drive interface to the form necessary to couple the tape drive to the host computer backplane bus. In most cases, the coupler design will be host- and peripheral device-specific. In some cases the coupler may also be application-specific.

EDITING A RECORD

Most nine-track drives also permit editing a data record. This means a record can be rewritten without destroying the data on either side of it. Of course the rewritten (edited) records must not change in length.

EOT

End of Tape, as indicated by the reflective EOT marker (EOT Tab) nominally 25 feet from the physical end of tape on the bottom side of the tape.

FILE

A group of one or more records ending with a Filemark. The number of records in a file is determined by the user. There may be one or more files on a tape.

FILEMARK

A special control record which is uniquely distinguished from any possible data record. Filemarks are often referred to as Tapemarks. The primary purpose of a filemark is to separate data records belonging to different files. Two successive Filemarks are frequently used to indicate a "logical EOT".

FORMATTER

That portion of the tape drive electronics which is devoted to format-related tasks and which interfaces directly to the coupler.

INTERRECORD GAP

An erased portion of tape between two records. Typically 0.6 inches long between data records and after a filemark and 3.75 before a filemark. The IRG is required by start/stop drives and is implemented by streamers to maintain compatibility. The IRG is also referred to as the InterBlock Gap.

NINE-TRACK, HALF-INCH, REEL TO REEL TAPE

This is the standard medium of archival data storage and interchange for mainframe and minicomputers.

Nine-track formats differ from most other tape formats in that they record an entire byte of data (8 bits) in parallel across the width of the tape along with a parity bit which is used to check and correct any errors encountered during reading of the data. There are four formats presently in use:

DENSITY	DATA ENCODING SCHEME
800Bpi	Non-Return-to-Zero Inverted (NRZI)
1600 Bpi	Phase Encoded (PE)
3200 Bpi	Phase Encoded (Double PE, or DPE)
6250 Bpi	Group Code Recording (GCR)

PHASE ENCODED (PE)

PE records 1600 characters per inch (CPI) and is the most widely used format. It is considerably more reliable than 800 CPI NRZI because the read decoding of each track is self-clocking. The read circuitry is very tolerant of tape skew and can compensate for the failure of any single track by reconstructing its data from that of the remaining 8 tracks.

RECORDS

All nine-track formats record data in records (blocks) with gaps between the records (interrecord gaps). This scheme allows the data to be read in small increments (one record minimum). The drive may be stopped between records to allow the host computer to digest the data. Record sizes can vary from a single byte to the length of the tape. There are several good reasons, however, for using records in the range of 256 to 64K bytes.

READ AFTER WRITE HEAD

Many nine-track tape drives employ separate write and read heads and are capable of simultaneously reading the data from the tape as it is being written. The big advantage of reading while writing is that any defects in the media can be detected immediately without spending additional time for a second verification pass. In addition, most read while write drives increase the read threshold (minimum read signal amplitude required for a valid data bit) during writing to detect any tape defects which are considered marginally acceptable. This enhances the reliability of subsequently reading the same data.

When errors are detected while writing data, the drive is instructed to backspace across the record and erase that portion of the tape (containing the defect). The record is then re-written over the following portion of the tape. This scheme is analogous to mapping and de-allocating bad sectors on disk drives, but instead of occurring only upon the initial formatting of the media, it is performed every time data is written to the tape.

REINSTRUCT TIME

A time window during which new commands will be accepted. If the new command accepted during this window is of a like direction and function of the previous command, the drive will continue with the new command without any interruption in tape motion.

The reinstruct time window begins upon reading the end of the present data block or filemark (as indicated by the rising edge of the IDBY signal) and continues for approximately 0.3 inches for write operations and 0.43 inches for read operations.

REPOSITION (Repositioning)

This terminology is defined here in the context of streaming tape drives.

Repositioning is the process of slowing the tape to a stop, then accelerating the tape back up to speed in the opposite direction (passing back over the IBG usually) and finally stopping the tape ahead or behind the desired position of the next block to be read or written. The tape is intentionally positioned well in advance of the IBG, in order to allow sufficient distance to accelerate the tape up to full speed before the start of the next block.

Streaming tape drives achieve a cost/performance improvement over "start/stop" drives by eliminating the capstan motor and tape loop storage devices. Start/Stop drives can start or stop in typically 0.2 inches (1/3 of an IBG) while streamers take several inches. To compensate for the longer start ramps, the tape must be positioned ahead of the desired starting position by at least the expected start distance. This will assure the desired speed will be reached before the beginning of the next data block.

Consider the following example:

Assume that the tape is moving at a constant velocity in the forward direction. As the end of the block passes the read head the tape position is noted, IDBY is raised and the reinspect time begins. If a new command is received before the reinspect time elapses, then tape motion will be maintained in the forward direction.

If a command is NOT received before the reinspect time elapses (i.e. a command overrun), then the tape transport automatically starts a repositioning cycle. The tape is stopped, then restarted in the opposite direction. When the noted position is in front of the read head (supply reel side of head) by a small cushion distance (safety factor), the tape is stopped and will remain so until another command is received.

It is permissible to issue a new command at any time during the reposition cycle. However, it will not be acted upon until repositioning is complete. Access time is defined as the time from the issuance of a command to the true-going edge of IDBY.

STREAMING

In the general sense, streaming means the handling of data with essentially continuous flow (i.e. a stream).

The more specific case applicable to streaming tape drives involves more than the general definition. Streaming is defined as the process of maintaining a continuous flow of data without incurring the delay (time overhead) of a reposition cycle.

Streaming is obtained by having the host computer and/or coupler issue the next command during the reinspect time. Doing so allows continuous tape motion to occur between the writing or reading of successive data blocks which are separated by IBG's (inter-block gaps).

TAPE DRIVE

This means the same thing as tape transport. The mechanism and associated electronics for handling, writing, erasing and reading tape. In the case of the Qualstar tape drive, the formatter is built into the tape drive.

VOM

Volt Ohm Meter

APPENDIX B: FRU SPARE PARTS LIST

PART NO.	FIELD REPLACEABLE UNIT	QUANTITY	REMARKS
500002-01-9	Tach Disk	1	
500015-01-1	Tape Guide	2	
500039-01-1	EOT/BOT Sensor Assembly	1	
500047-01-4	Read/Formatter PCBA	1	
500057-01-3	Write/Controller PCBA	1	
500071-02-2	Cable Assembly, Read	1	1052
500087-01-0	Power Supply PCBA	1	1052/1600, 1052, 1053R
500087-02-8	Power Supply PCBA	1	1053, 1054
500087-03-6	Power Supply PCBA	1	1053B
500107-01-6	Hall Switch PCBA	1	
500117-01-5	Switch Interconnect PCBA	1	
500177-01-9	Buffered Interface PCBA	1	1053B
500214-01-0	Supply Reel Hub Assembly, PE	1	
500214-03-6	Take Up Hub Assembly, PE	1	
600-0022-1	Motor	2	
604-0010-8	Fan, 21 CFM, DC	1	
610-0004-8	Switch, Rocker, 2 pole	1	
613-0001-8	Switch, "LOAD"	1	
613-0002-6	Switch, "FPT"	1	
613-0004-8	Switch, "3200"	1	
626-0001-0	Fuse, 3 Amp, 3AG, Slo-Blo, 250V	1	1053B
626-0002-8	Fuse, 1.5 Amp, 3AG, Slo-Blo, 250V	1	1053B
626-0003-6	Fuse, 2 Amp, 3AG, Slo-Blo, 250V	1	100/120 VAC
626-0004-6	Fuse 1 Amp, Slo-Blo, 250V, 5X20mm	1	220/240 VAC
630-0011-1	Transformer	1	All models except 1053B
630-0012-9	Transformer	1	1053B
632-0835-9	Optical Switch	2	
633-0002-4	Filter, Line	1	
645-0001-0	Head, nine-track	1	
712-1410-0	Shim, .001 Thick, .147 ID, .380 OD	As required	Skew adjust
712-1411-8	Shim, .004 Thick, .148 ID, .375 OD	As required	Skew adjust
716-2501-6	Bearing, .250 ID	4	
738-0004-7	SCSI Interface PCBA	1	1054

COPYRIGHT 1987 BY QUALSTAR CORPORATION

The information herein is the property of Qualstar Corporation. No portion of this data shall be released, disclosed, used, or duplicated for procurement or manufacturing purposes without specific written consent from Qualstar Corporation.

LTR.	CHANGES	D
A	RELEASED	10/
B	REVISED & REDRAWN	03/

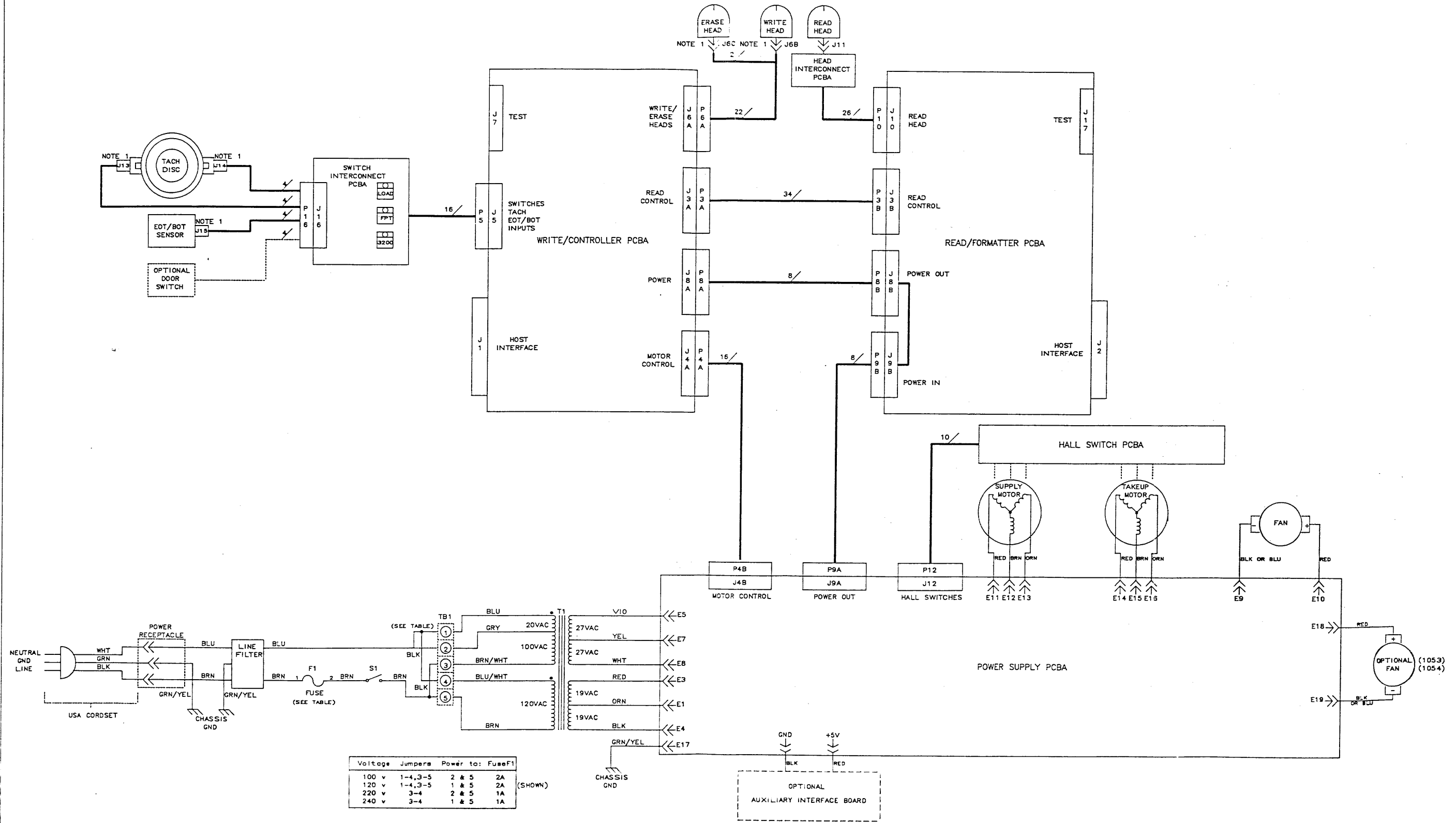

1. CONNECT WITH COLORED WIRE CLOSEST TO CASTING. NOTES UNLESS OTHERWISE SPECIFIED:

DESIGN: R. NELSON	09/09/85	QUALSTAR CORPORATION
DRAWN: R. NELSON	09/09/85	TITLE SYSTEM INTERCONNECT DIAGR
CHECK:		MODELS: 700,701,1052,1053,105
APPROV:		SIZE CODE NUMBER
		D CED 500030
DATE SEP 09, 1985		SHEET 1 OF

REVISIONS			
ZONE	LTR	DESCRIPTION	DATE
ALL	E1	REDESIGNED & REDRAWN	9-25-86
ALL	F1	ADDED R36 & C77 EN COG	9-9-88

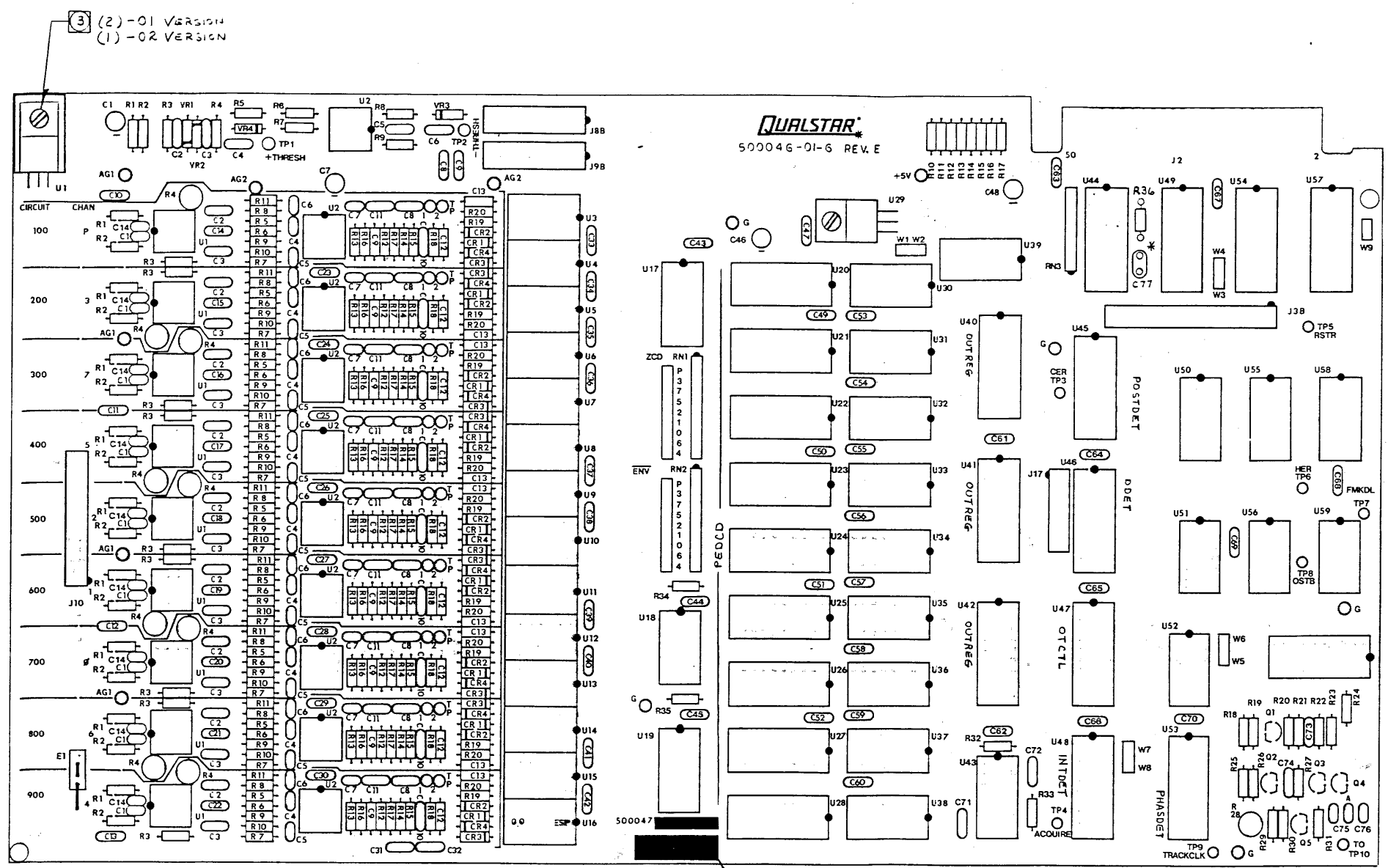

2 CENTERS
1 CENTERS
* POSITION FOR C77

- ③ INSTALL HOW AFTER SOLDERING.
- ② ID WITH L.M. DASH NO'S AND REV. LETTER, BLACK INK.
- ① FOR -2 VERSION, ONLY; CUT TRACE W1, FAR SIDE; INSTALL JUMPER WIRE W0, NEAR SIDE; CUT TRACE W5, FAR SIDE; INSTALL JUMPER WIRE W6, NEAR SIDE.

NOTE: UNLESS OTHERWISE SPECIFIED

UNLESS OTHERWISE SPECIFIED: DIMENSIONS ARE IN INCHES. TOLERANCES ON: FRACTIONS .X .XX .XXX ± DECIMALS .X .XX .XXX ± ANGLES ± ± ± ±		CONTRACT NO.	QUALSTAR
DR BY: <i>S. J. Adams</i> 9/25/86	CHK BY:	APPROVED BY:	
MATERIAL:	FINISH:	SCALE 1/2"=1"	SIZE PROD. CODE DWG. NO. REV.
NEXT ASSY:	USED ON:	APPLICATION:	D 500047 F1
DO NOT SCALE DRAWING			SHEET 1 OF 1

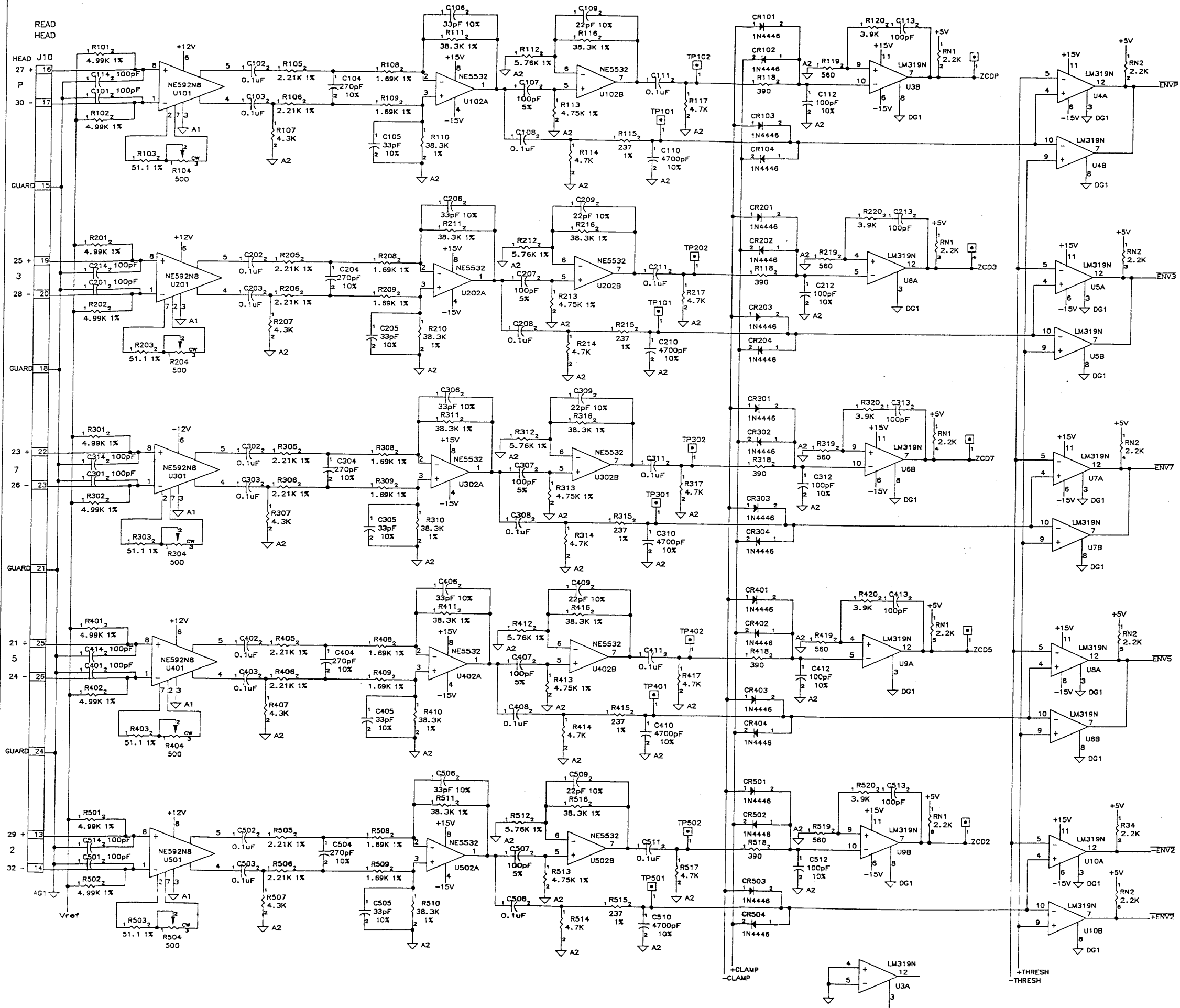

LTR.	CHANGES	DATE
C	RELAYOUT & PRODUCTION RELEASE	05/21
C1	NO CHANGE THIS SHEET	09/21
D1	NO CHANGE THIS SHEET	10/21
E1	COMMON ENV/ SIGNALS	09/21
F1	NO CHANGES THIS SHEET	09/01
F2	EN025 NO SCH. CHANGES	09/21
F3	EN051 - WRITE THRESHOLD REDUCTIONS	03/21

COPYRIGHT 1986 BY QUALSTAR CORPORATION
 The information herein is the property of Qualstar Corporation. No portion of this data shall be released, disclosed, used, or duplicated for procurement or manufacturing purposes without specific written consent from Qualstar Corporation.

DESIGN: R. NELSON	07/08/86	QUALSTAR CORPORATION	
DRAWN: R. NELSON	07/08/86	TITLE SCHEMATIC DIAGRAM	
CHECK:		READ / FORMATTER BOARD	
APPROV:		SIZE	CODE NUMBER
APPROV:		D	CED 500048
		DATE	SHEET 1 OF 3

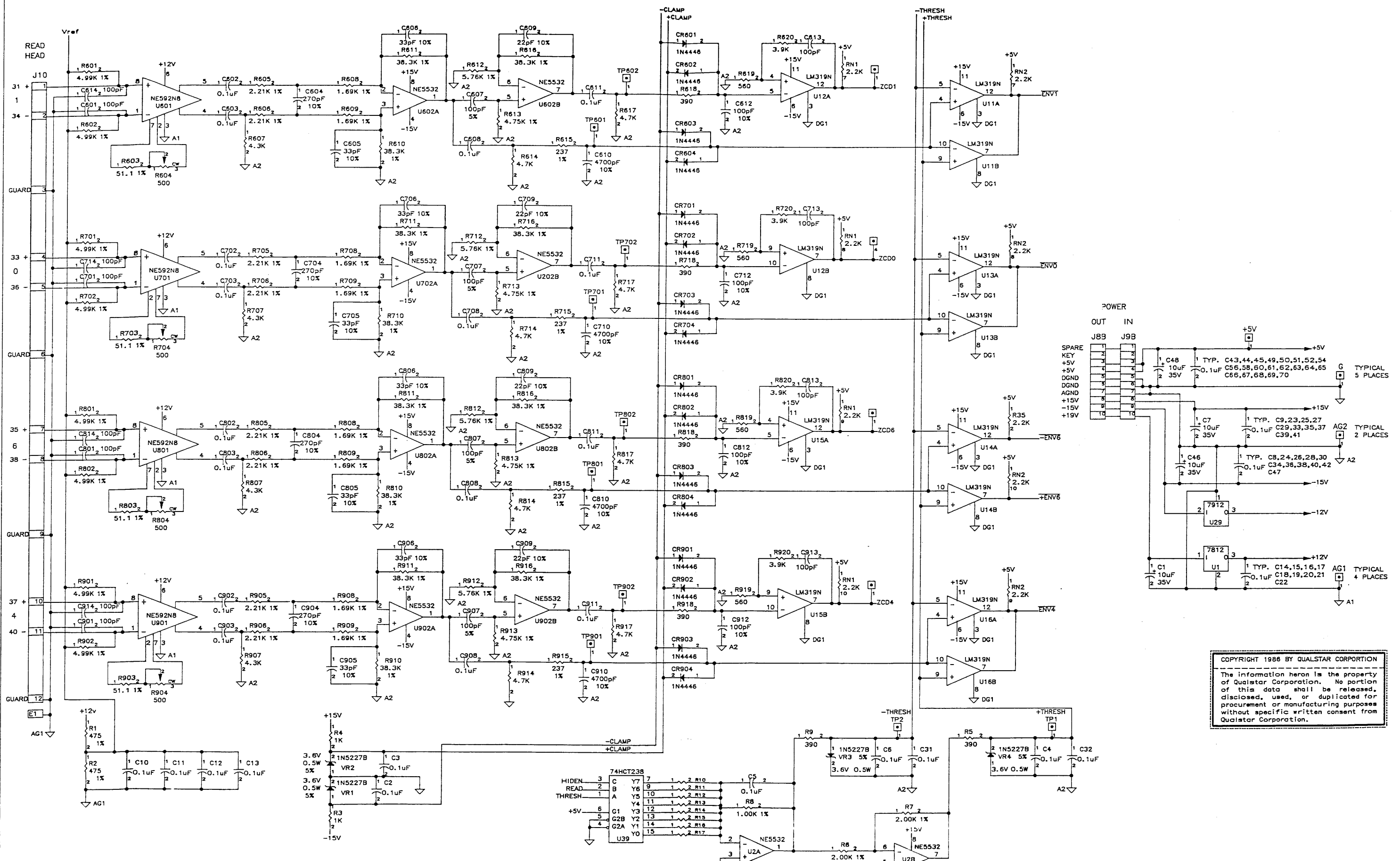

COPYRIGHT 1986 BY QUALSTAR CORPORATION
 The information herein is the property of Qualstar Corporation. No portion of this data shall be released, disclosed, used, or duplicated for procurement or manufacturing purposes without specific written consent from Qualstar Corporation.

MODE	Y#	R#	OHMS	VOLTS
1600 WRITE	0	R17	10.0K	500mV
1600 READ	2	R15	12.1K	413mV
3200 WRITE	4	R13	33.2K	150mV
3200 READ	6	R11	49.9K	100mV
	7	R10	100.0K	50mV

DESIGN: R. NELSON	07/08/86	QUALSTAR CORPORATION	
DRAWN: R. NELSON	07/08/86	TITLE SCHEMATIC DIAGRAM	
CHECK:		READ / FORMATTER BOARD	
APPROV:		SIZE	CODE NUMBER
APPROV:		D	CED
			500048
			REV F3
		DATE	SHEET 2 OF 3

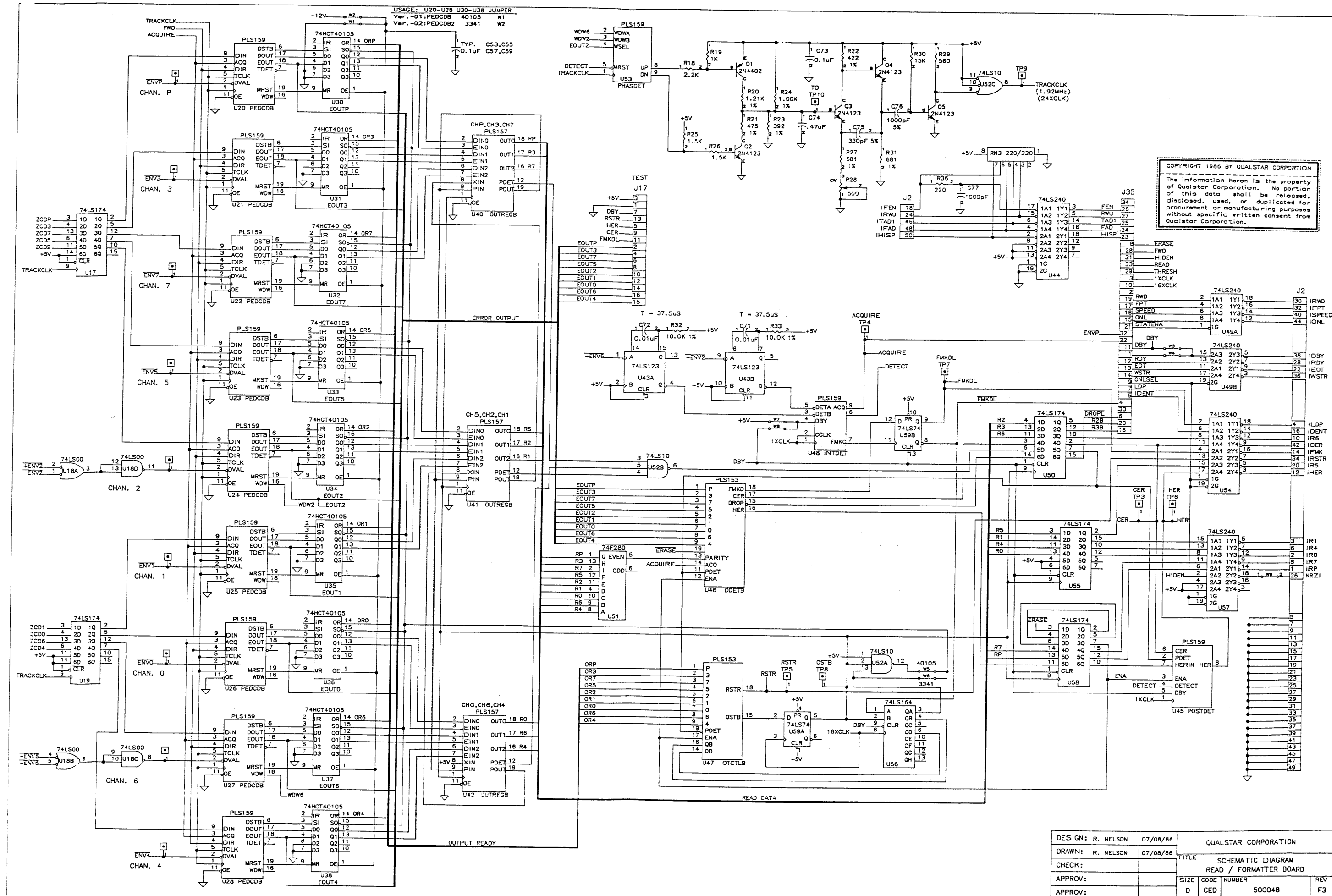

COPYRIGHT 1986 BY QUALSTAR CORPORATION
 The information herein is the property of Qualstar Corporation. No portion of this data shall be released, disclosed, used, or duplicated for procurement or manufacturing purposes without specific written consent from Qualstar Corporation.

DESIGN: R. NELSON	07/08/86	QUALSTAR CORPORATION
DRAWN: R. NELSON	07/08/86	TITLE
CHECK:		SCHEMATIC DIAGRAM
APPROV:		READ / FORMATTER BOARD
APPROV:		SIZE CODE NUMBER
		D CED 500048
		REV F3
		DATE SEP 09, 1988
		SHEET 3 OF 3

REVISIONS				
ZONE	LTR	DESCRIPTION	DATE	APPROV

L
C
B
A

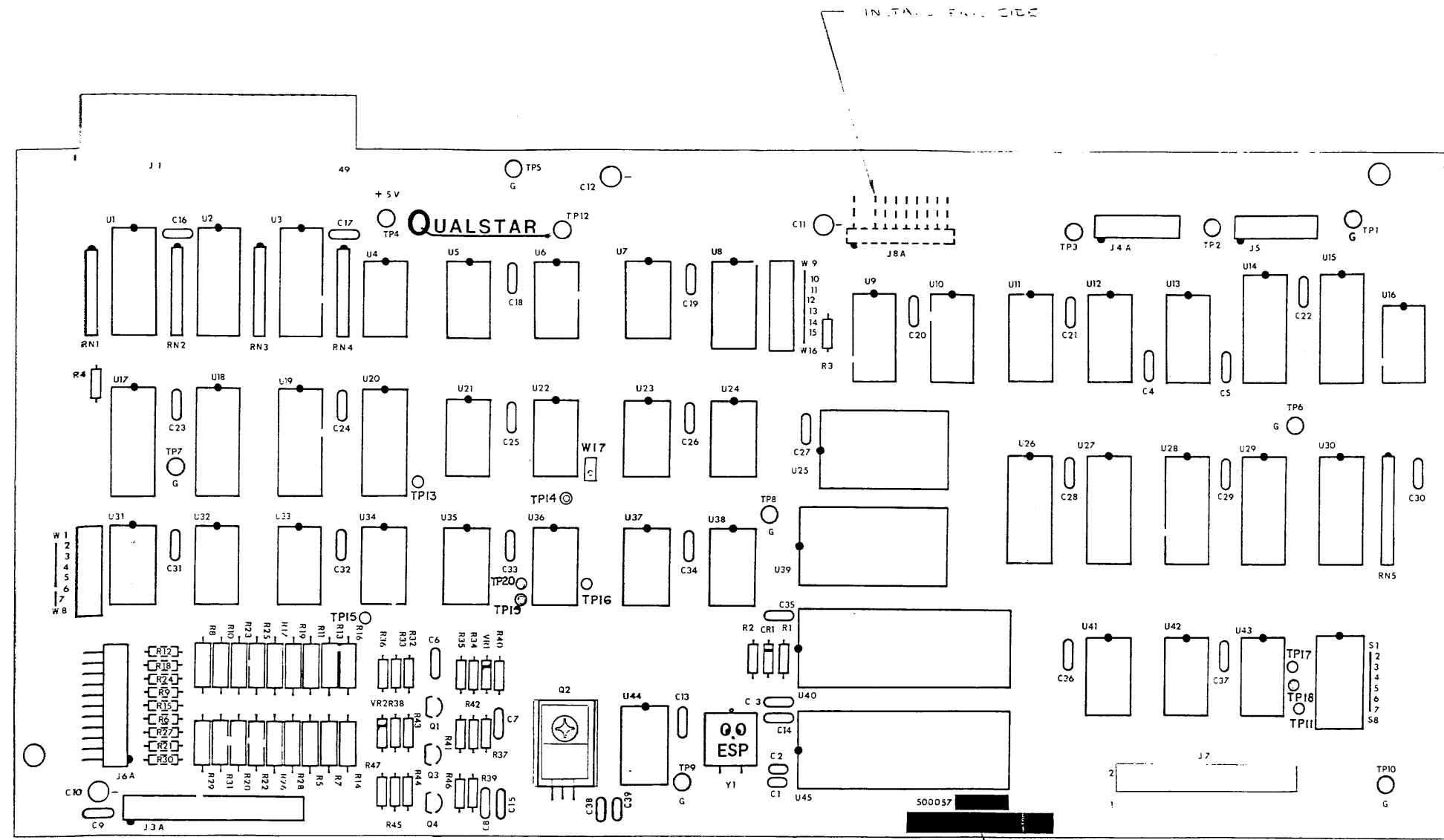

NOTE: UNLESS OTHERWISE SPECIFIED

UNLESS OTHERWISE SPECIFIED: DIMENSIONS ARE IN INCHES. TOLERANCES ON: FRAC. DECIMALS ANGLES TIONS X XX XXX ±		CONTRACT NO.		QUALSTAR	
MATERIAL		DR BY			
FINISH		CHK BY		REVISIONS	
NEXT ASSY		APPROVED BY		SIZE PROD. CODE DWG. NO. RE	
USED ON				D 500057 01	
APPLICATION		DO NOT SCALE DRAWING		SCALE SHEET OF	

LTR.	CHANGES	DATE
A1	PRELIMINARY RELEASE	01/18/85
B1	MAJOR REVISION	04/15/85
C1	HOLE SIZE CHANGES, NO SCHEM. CHGS.	
D1	ADD CDBY TO J3A-1, TP13-TP20, W17	10/02/86

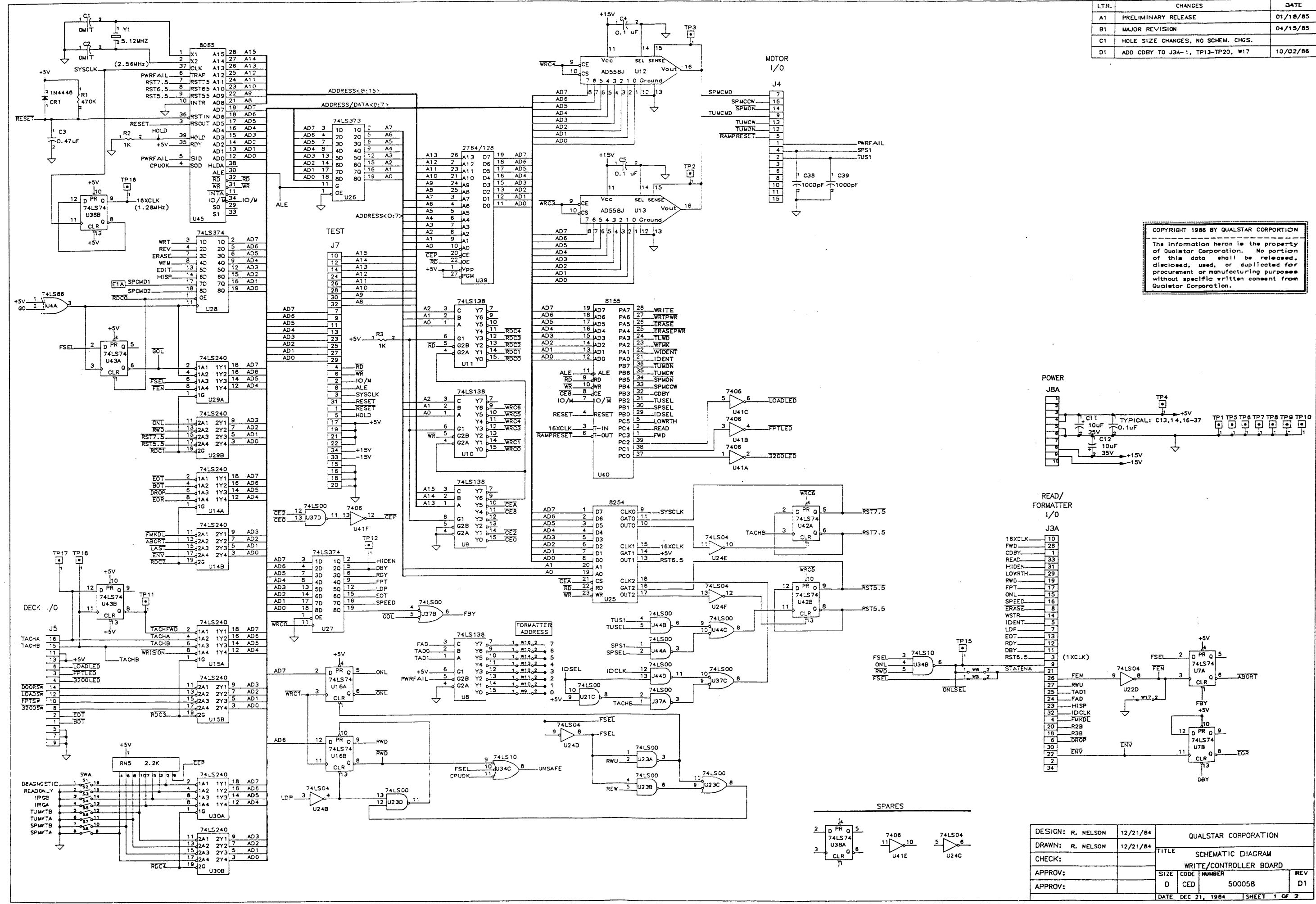

COPYRIGHT 1986 BY QUALSTAR CORPORATION
 The information herein is the property of Qualstar Corporation. No portion of this data shall be released, disclosed, used, or duplicated for procurement or manufacturing purposes without specific written consent from Qualstar Corporation.

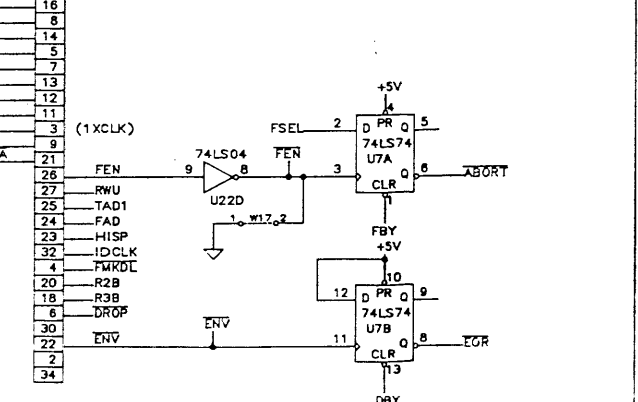
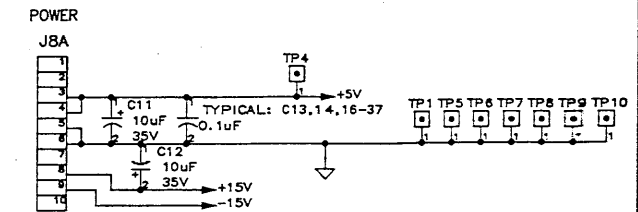

DESIGN: R. NELSON	12/21/84	QUALSTAR CORPORATION	
DRAWN: R. NELSON	12/21/84	TITLE SCHEMATIC DIAGRAM	
CHECK:		WRITE/CONTROLLER BOARD	
APPROV:		SIZE D	CODE CED
APPROV:		NUMBER 500058	REV D1
DATE DEC 21, 1984		SHEET 1 OF 2	

LTR.	CHANGES	DATE
A1	PRELIMINARY RLL LAGE	01/18/85
B1	MAJOR REVISION	04/15/85
C1	CHANGE HOLE SIZES, NO SCHEM. CHGS.	
D1	ADD CDBY TO J3A-1, TP13-20, W17	10/02/86

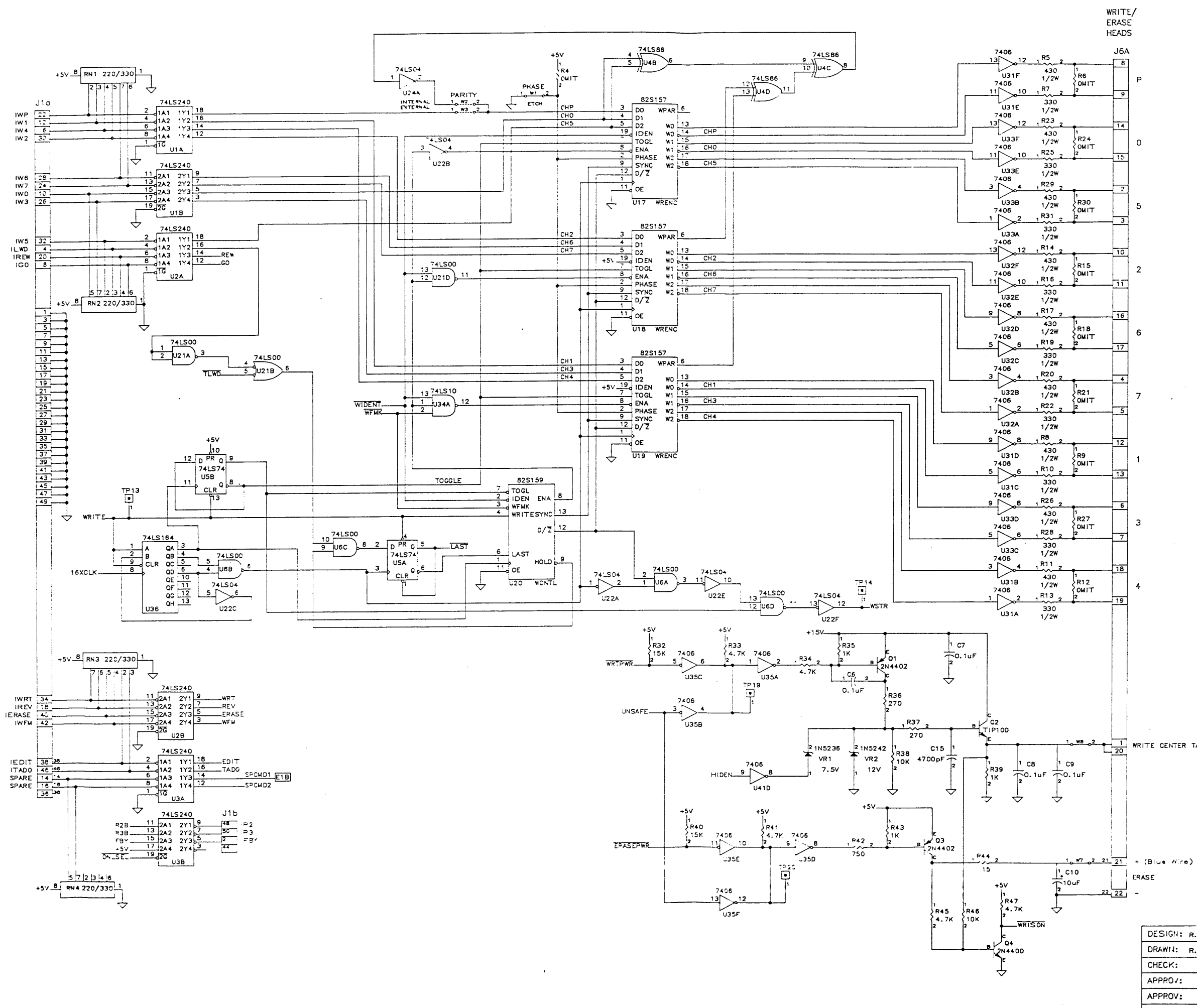

COPYRIGHT 1986 BY QUALSTAR CORPORATION
 The information herein is the property of Qualstar Corporation. No portion of this data shall be released, disclosed, used, or duplicated for procurement or manufacturing purposes without specific written consent from Qualstar Corporation.

DESIGN: R. NELSON	12/21/84	QUALSTAR CORPORATION			
DRAWN: R. NELSON	12/21/84	TITLE SCHEMATIC DIAGRAM			
CHECK:		WRITE/CONTROLLER BOARD			
APPROV:		SIZE	CODE	NUMBER	REV
APPROV:		D	CE	500058	D1
		DATE DEC 21, 1984		SHEET 2 OF 2	

REVISIONS				
ZONE	LTR	DESCRIPTION	DATE	APPROV
ALL	E1	REVISED & RE-DRAWN	10-10-65	

D
C
B
A

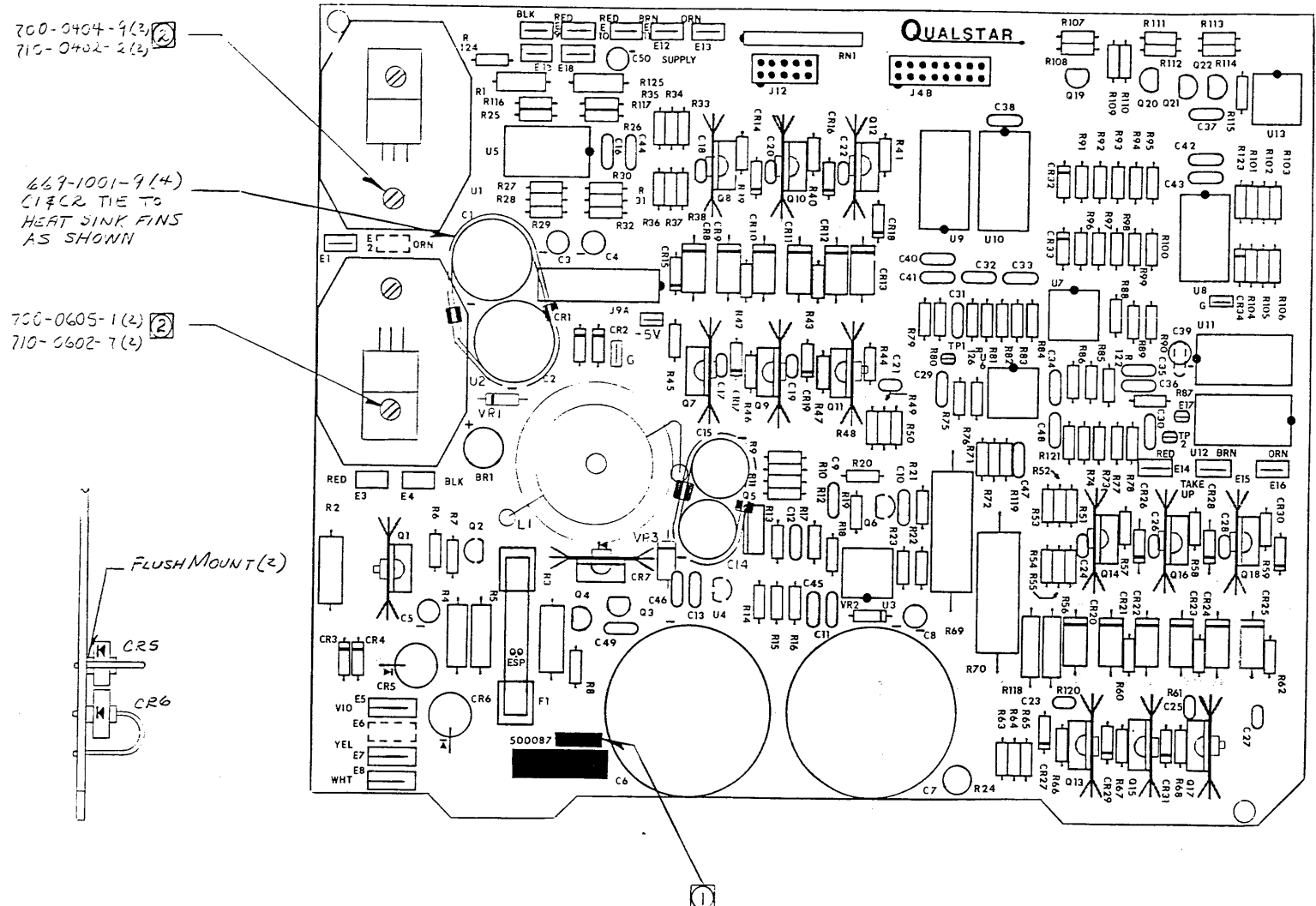

700-0404-9(2)
710-0402-2(2)

669-1001-9(4)
C1&C2 TIE TO
HEAT SINK FINS
AS SHOWN

700-0605-1(2)
710-0602-7(2)

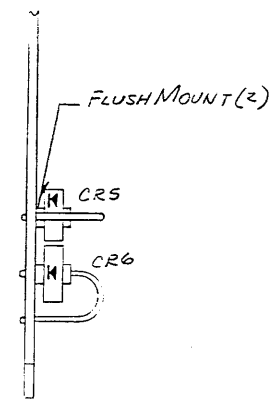

- ② HDW ON FAR SIDE TO BE FREE OF SOLDER
- ① ID WITH LM DASH NO'S AND REV LETTER IN BLACK INK.

NOTE: UNLESS OTHERWISE SPECIFIED

UNLESS OTHERWISE SPECIFIED: DIMENSIONS ARE IN INCHES. TOLERANCES ON: FRAC. DECIMALS ANGLES TIONS X XX XXX ± ± ± ± ±		CONTRACT NO.		QUALSTAR	
MATERIAL		DR BY <i>Swick</i> / <i>10/10/65</i>			
FINISH		CHK BY		POWER SUPPLY PCBA	
NEXT ASSY		APPROVED BY			
APPLICATION		DO NOT SCALE DRAWING		SIZE	REV.
				D	E1
				SCALE 1/2"	SHEET 1 OF 1

8 7 6 5 4 3 2 1

LTR.	CHANGES	DATE
A	PRELIMINARY RELEASE	02/11/85
B	MAJOR REVISION - PRODUCTION RELEASE	05/20/85
C	MINOR REVISIONS	06/18/85
D1	ADD BRAKE PWR, CHANGE FAN POWER	10/01/85
E1	CHANGE L1 LAYOUT, ADD VR3, -02 OPTION	09/26/86
E2	VOID	
E3	CHANGE R85 & R126 FROM 4.99K TO 20.0K	02/07/87
E4	REVISED PER EN042	12/08/89
E5	REVISED PER EN039	01/27/90
E6	REVISED PER EN083	03/29/90
E6A	REVISED PER EN095	05/16/90
E7	REVISED PER EN108	05/16/90

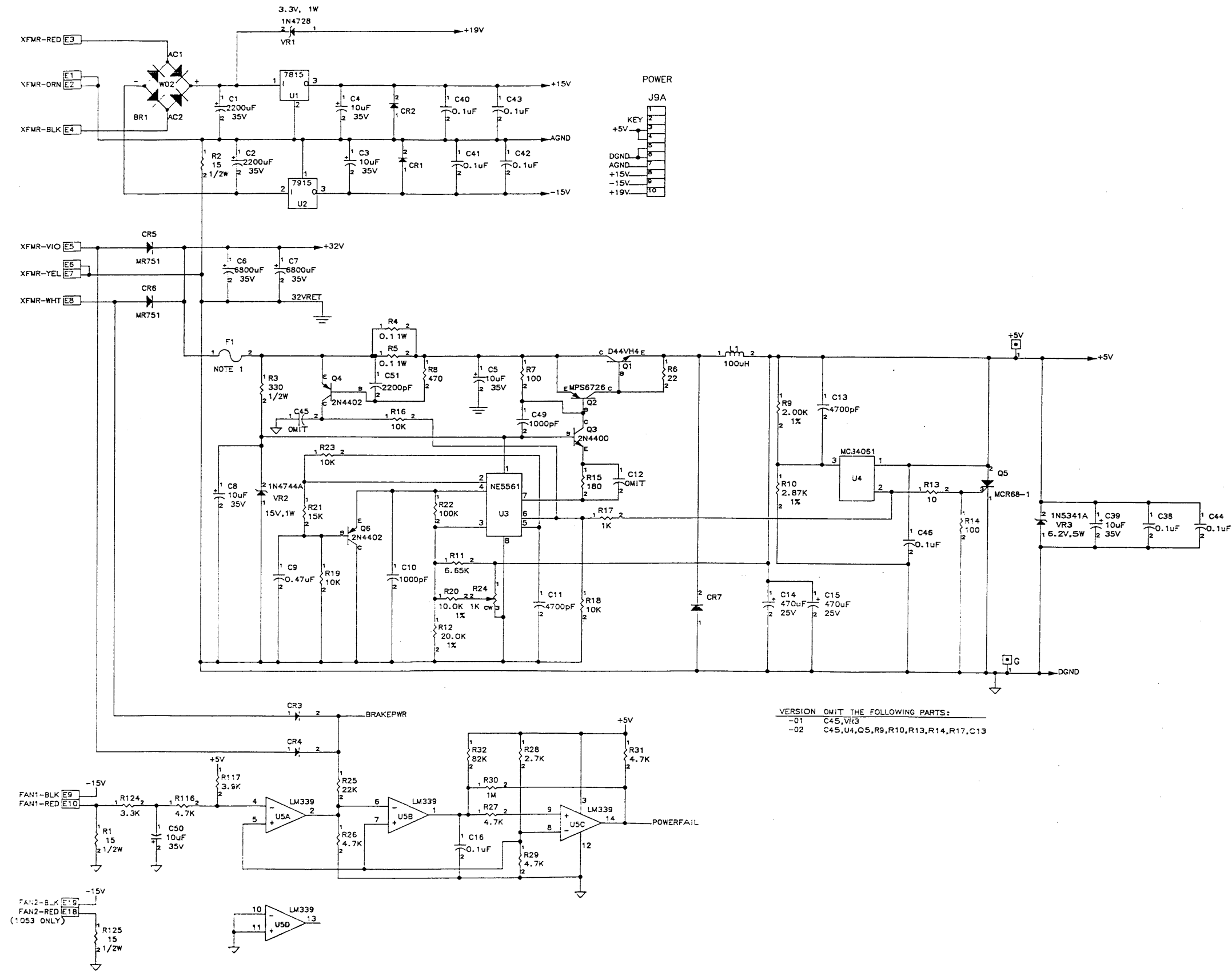

VERSION OMIT THE FOLLOWING PARTS:
 -01 C45,VR3
 -02 C45,U4,Q5,R9,R10,R13,R14,R17,C13

COPYRIGHT 1986 BY QUALSTAR CORPORATION
 The information herein is the property of Qualstar Corporation. No portion of this data shall be released, disclosed, used, or duplicated for procurement or manufacturing purposes without specific written consent from Qualstar Corporation.

2 FOR 500087-01-0 & -02-R5 = 0.05 OHMS, 1 WATT, FOR -03-R5 = 0.1 OHM, 1 WATT
 1. FOR 500087-01-0 & -02-F1 = 4A, 32V; FOR -03-F1 = 6A, 32V
 NOTES UNLESS OTHERWISE SPECIFIED:

DESIGN: R. NELSON	01/07/85	QUALSTAR CORPORATION		
DRAWN: R. NELSON	01/07/85	TITLE SCHEMATIC DIAGRAM		
CHECK:		POWER BOARD		
APPROV:		SIZE D	CODE CED	NUMBER 500088
APPROV:		REV E7		
DATE JAN 07, 1985		SHEET 1 OF 2		

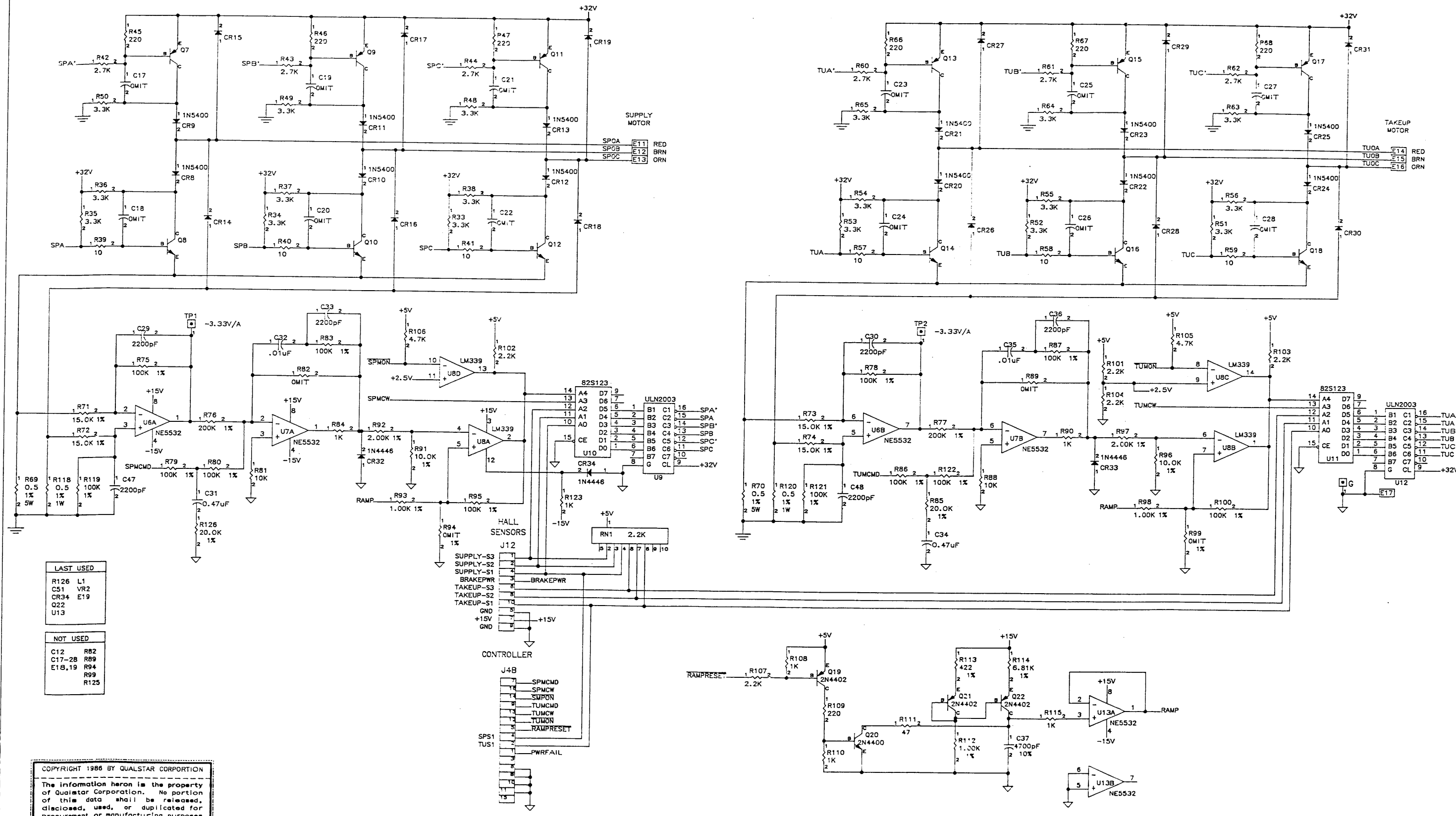

- LAST USED**
- R126 L1
 - C51 VR2
 - CR34 E19
 - Q22
 - U13

- NOT USED**
- C12 R82
 - C17-28 R89
 - E18,19 R94
 - R99
 - R125

COPYRIGHT 1986 BY QUALSTAR CORPORATION
 The information herein is the property of Qualstar Corporation. No portion of this data shall be released, disclosed, used, or duplicated for procurement or manufacturing purposes without specific written consent from Qualstar Corporation.

DESIGN: R. NELSON	01/07/85	QUALSTAR CORPORATION	
DRAWN: R. NELSON	01/07/85	TITLE SCHEMATIC DIAGRAM	
CHECK:		POWER BOARD	
APPROV:		SIZE CODE NUMBER	REV
APPROV:		D CED 500088	E7
DATE JAN 07, 1985		SHEET 2 OF 2	

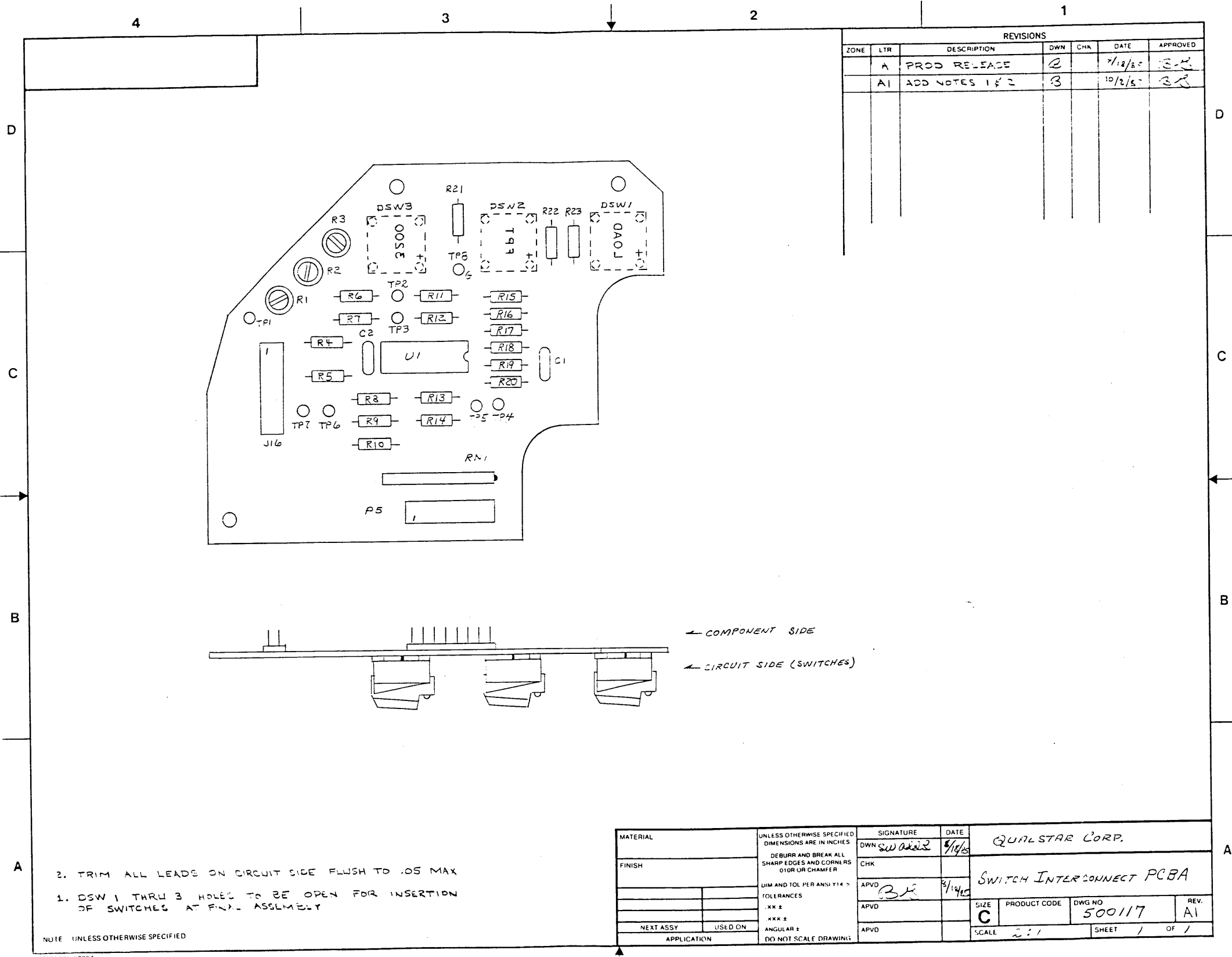

REVISIONS						
ZONE	LTR	DESCRIPTION	DWN	CHK	DATE	APPROVED
	A	PROD RELEASE	2		7/18/85	BR
	A1	ADD NOTES 1 & 2	3		10/2/85	BR

2. TRIM ALL LEADS ON CIRCUIT SIDE FLUSH TO .05 MAX
1. DSW 1 THRU 3 HOLES TO BE OPEN FOR INSERTION OF SWITCHES AT FINAL ASSEMBLY

NOTE: UNLESS OTHERWISE SPECIFIED

FORM NO. 10322A

MATERIAL	UNLESS OTHERWISE SPECIFIED DIMENSIONS ARE IN INCHES	SIGNATURE	DATE	QUALSTAR CORP.	
FINISH	DEBUR AND BREAK ALL SHARP EDGES AND CORNERS 0.10R OR CHAMFER	DWN swakar	8/1/85	SWITCH INTERCONNECT PCBA	
	DIM AND TOL PER ANSI Y14.5	CHK		SIZE	PRODUCT CODE
	TOLERANCES	APVD BR	8/1/85	C	500117
	.XX ±			DWG NO	REV.
	.XXX ±				A1
NEXT ASSY	USED ON			SCALE	SHEET
APPLICATION				2:1	1 OF 1
	DO NOT SCALE DRAWING				

LTR.	CHANGES	DATE
A	INITIAL RELEASE	09/16/85
A6	CHANGED RESISTOR VALUES	01/27/86

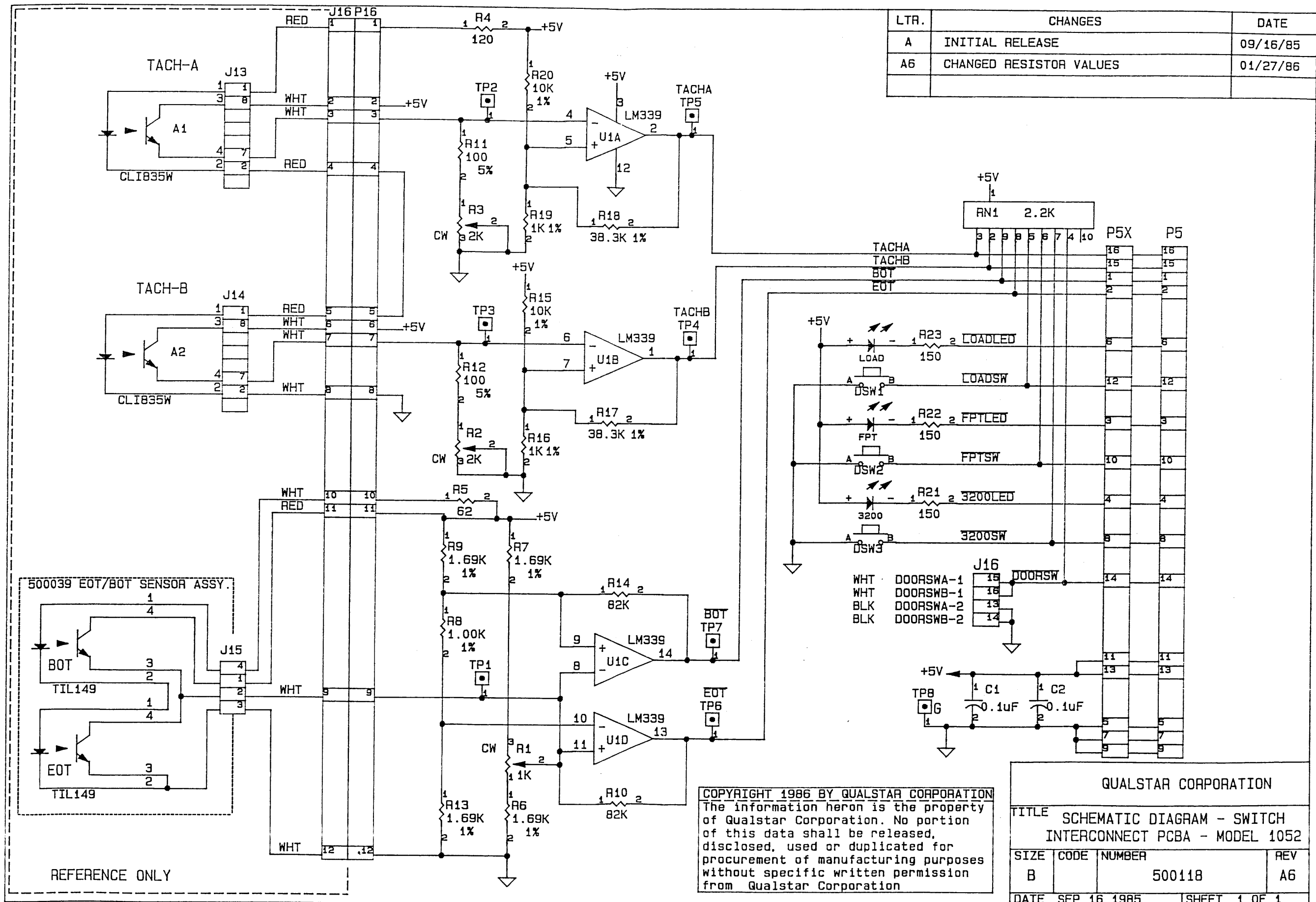

COPYRIGHT 1986 BY QUALSTAR CORPORATION
 The information herein is the property of Qualstar Corporation. No portion of this data shall be released, disclosed, used or duplicated for procurement of manufacturing purposes without specific written permission from Qualstar Corporation.

QUALSTAR CORPORATION			
TITLE SCHEMATIC DIAGRAM - SWITCH INTERCONNECT PCBA - MODEL 1052			
SIZE	CODE	NUMBER	REV
B		500118	A6
DATE SEP 16 1985		SHEET 1 OF 1	

REFERENCE ONLY

REVISIONS						
ZONE	LTR	DESCRIPTION	DWN	CHK	DATE	APPR
	A	PRODUCTION RELEASE	BJS		1/2/87	CS
	B	COMPLETELY REVISED	BJS		1/23/88	CS

D
C
B
A

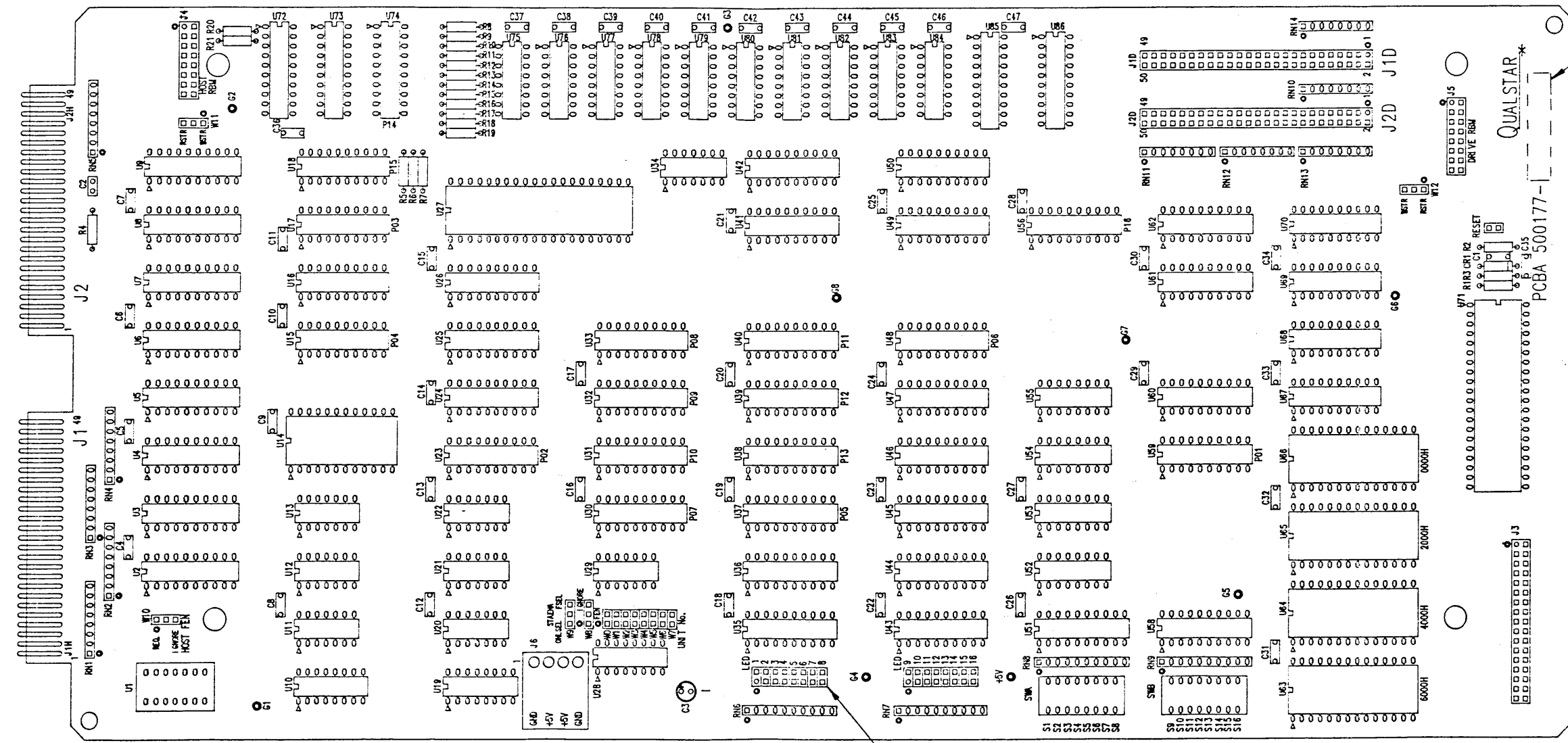

ANNODE SIDE 16 PLCS
(LONG LEAD)

LED 1
THRU 16
TYPICAL

ANNODE
(LONG LEAD)

IDENTIFY WITH VERSION AND REVISION LTR IN BLOCK SHOWN.

NOTE, UNLESS OTHERWISE SPECIFIED

MATERIAL	UNLESS OTHERWISE SPECIFIED DIMENSIONS ARE IN INCHES DEBURR AND BREAK ALL SHARP EDGES AND CORNERS 0.10R OR CHAMFER DIM AND TOL PER ANSI Y14.5. TOLERANCES XX ± XXX ± ANGULAR ±	SIGNATURE	DATE	 BUFFERED INTERFACE PCBA			
FINISH		CWN	BJS 1/2/87				
		CHK					
		APVD					
		APVD					
NEXT ASSY	USED ON			SIZE	PROD CODE	DWG NO.	RE
APPLICATION				D		500177	2
	DO NOT SCALE DRAWING			SCALE	1/2 TO 1	SHEET	1 OF 1

LTR.	CHANGES	DATE
A	INITIAL PCB RELEASE	09/14/87
B1	REVISED AND REDRAWN	03/17/88

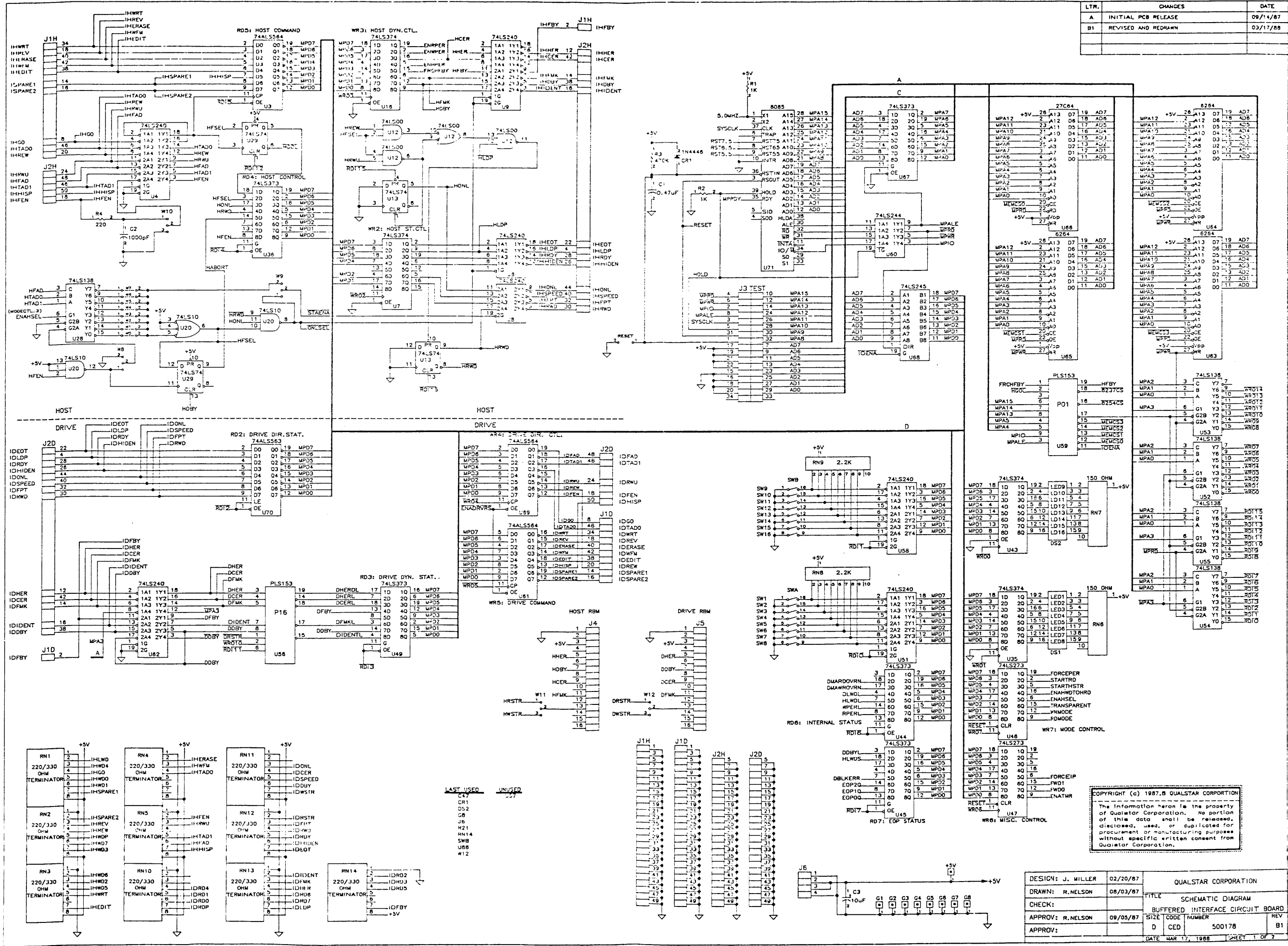

COPYRIGHT (c) 1987, QUALSTAR CORPORATION
 The information herein is the property of Qualstar Corporation. No portion of this data shall be released, disclosed, used, or duplicated for procurement or manufacturing purposes without specific written consent from Qualstar Corporation.

DESIGN: J. MILLER	02/20/87	QUALSTAR CORPORATION	
DRAWN: R. NELSON	08/03/87	TITLE	SCHEMATIC DIAGRAM
CHECK:		BUFFERED INTERFACE CIRCUIT BOARD	
APPROV: R. NELSON	09/05/87	SIZE CODE	NUMBER
APPROV:		D	CED
		500178	B1
		DATE MAR 17, 1988	SHEET 1 OF 2

LTR.	CHANGES	DATE
A	INITIAL PCB RELEASE	09/16/87
B1	REVISED AND REDRAWN	03/17/88

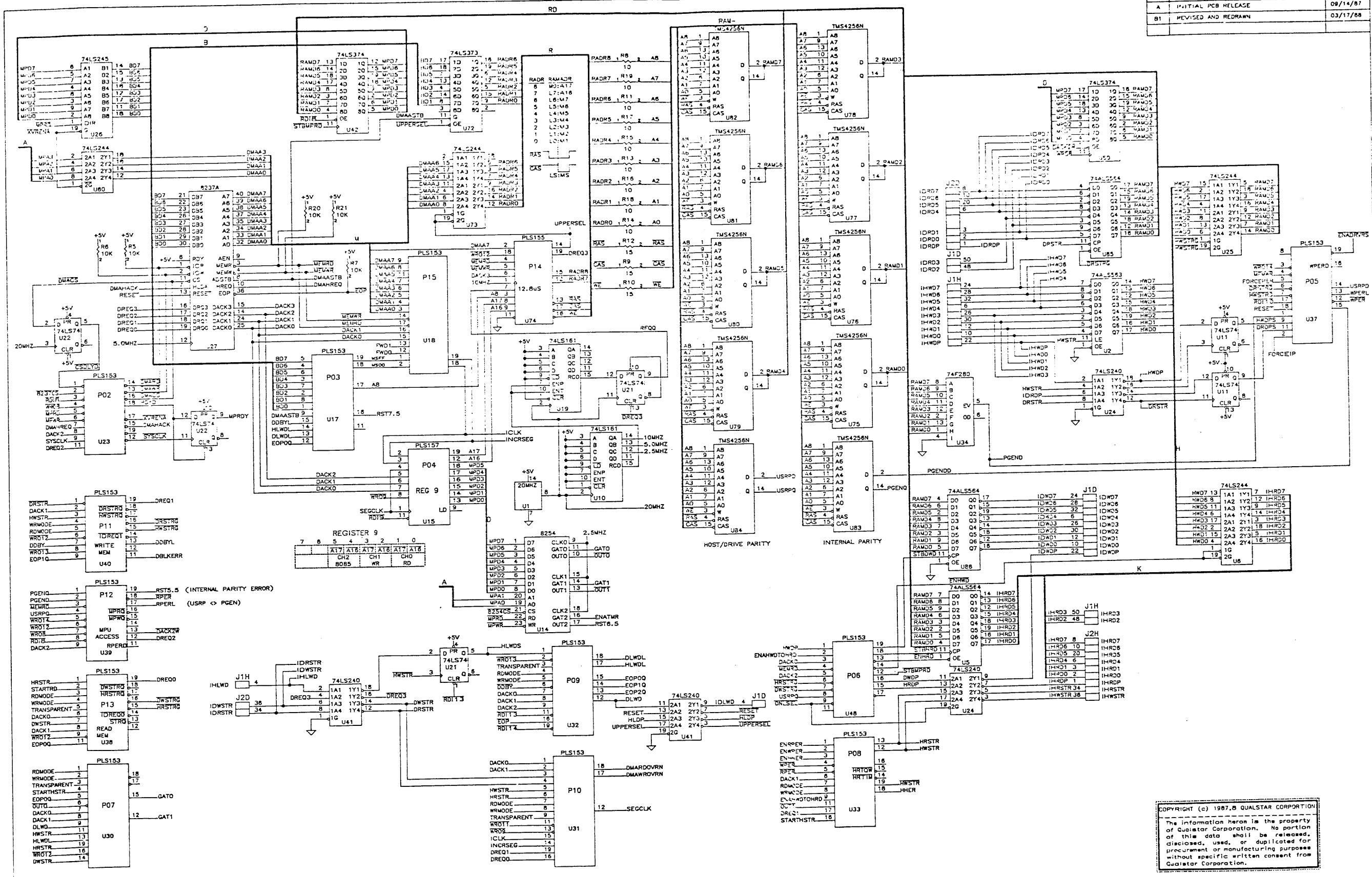

COPYRIGHT (c) 1987, QUALSTAR CORPORATION
 The information herein is the property of Qualstar Corporation. No portion of this data shall be released, disclosed, used, or duplicated for procurement or manufacturing purposes without specific written consent from Qualstar Corporation.

DESIGN: J. MILLER	02/20/87	QUALSTAR CORPORATION	
DRAWN: R. NELSON	08/03/87	TITLE	SCHEMATIC DIAGRAM
CHECK: R. NELSON	08/05/87	APPROVED	BUFFERED INTERFACE CIRCUIT BOARD
APPROV:		SIZE	CODE NUMBER
		D	CED
			500178
		DATE	MAR 17, 1988
		SHEET	2 OF 2