

Qume
A Subsidiary of **ITT**

QVT

119™

Setup Guide

FCC WARNING

This equipment generates, uses, and can radiate radio frequency energy and if not installed, maintained, and used in accordance with instructions contained in Qume manuals, may cause interference with radio communications. This equipment has been tested and found to comply with the limits for a Class A computing device pursuant to Subpart J of Part 15 of FCC Rules, which are designed to provide reasonable protection against such interference when operated in a commercial environment. Operation of the equipment in a residential area is likely to cause interference in which case the user, at his own expense, will be required to take whatever measures may be required to correct the interference.

WARNING

The ROM resident software incorporated in this product is protected by copyright and may not be copied or duplicated without the written authorization of Qume Corporation.

Reorder Number 35103-10
August 1985

© 1985 Qume Corporation, Printed in Taiwan, R. O. C.
DocuMinder, LetterPro, MicroDrive, Multistrike, PHD, ProFeeder, Q, QPW, Quickload, Qume, QumeTrak, QVT, Sprint, SprintFeed, Stockpak, SuperStrike, The Qume Connection, TriGimbal, Twintellect, TwinTrack, Wedge, and WideTrack are trademarks of Qume Corporation.

ADDS and ADDS A2 are registered trademarks of Applied Digital Data Systems, Inc. WYSE and WY-50 are registered trademarks of Wyse Technology.

QUME CORPORATION MAKES NO REPRESENTATION OR WARRANTIES OF ANY KIND WHATSOEVER WITH RESPECT TO THE CONTENTS HEREOF AND SPECIFICALLY DISCLAIMS ANY IMPLIED WARRANTIES OF MERCHANTABILITY OR FITNESS FOR ANY PARTICULAR PURPOSE. Qume Corporation shall not be liable for errors contained herein or for incidental or consequential damages in connection with the furnishing, performance, or use of this material. Qume Corporation reserves the right to revise this publication from time to time and to make changes in the content hereof without obligation to notify any person of such revision or changes.

Contents of this publication may be preliminary and/or may be changed at any time without notice and shall not be regarded as a warranty.

Qume
A Subsidiary of **ITT**

2350 Qume Drive, San Jose, California 95131, U.S.A., TWX 910-338-0232, Phone (408) 942-4000

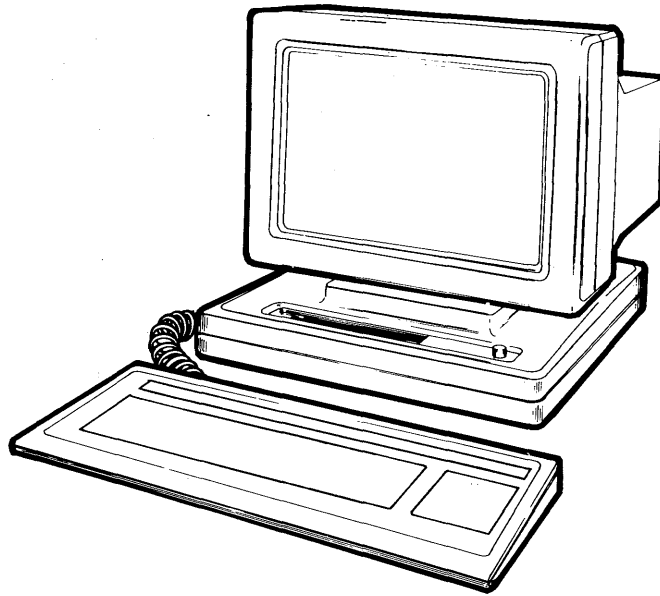

The QVT 119 Alphanumeric Display Terminal

PREFACE

The QVT 119™ Alphanumeric Display Terminal is command set compatible with ADDS A2 and Wyse 50 terminals.

Ergonomically designed, standard features of the QVT 119 terminal include an adjustable height, low-profile, detached keyboard, and a 14 inch non-glare monitor, housed in a display unit that features full tilt and swivel.

In performance, standard features of the QVT 119 terminal include: a bi-directional printer port; conversational and local mode operation; soft set non-volatile setup menus; green display with screen-saver; 80 columns displayable, 132 columns with horizontal scroll; double-high, double-wide characters; choice of special graphic character sets; and, compliance to the RS 232 Standard. Available as optional features, the terminal may be ordered with an amber display screen, current loop capability, or RS 422 Standard compliance.

ORGANIZATION

The purpose of the QVT 119 Setup Guide is to describe to users of the terminal, how to install the unit, and then configure it for compatibility with their host system.

The QVT 119 Setup Guide is organized as follows:

Section 1. **Installation, Connectors, and Controls** describes unpacking and installing the terminal, connecting it into your system, and user controls.

Section 2. **Getting Started** describes the ergonomic features of the terminal, powering On the terminal, the keyboard, setup mode, and using the status line.

Appendix

RELATED PUBLICATIONS

| | |
|--------------------------------------|-------------------------|
| QVT 119 Programmers Reference Manual | Reorder Number 35103-20 |
| QVT 119 Maintenance Guide | Reorder Number 35103-30 |
| QVT 119 Quick Reference Card | Reorder Number 35103-40 |

TABLE OF CONTENTS

| | Page |
|---|------------|
| SECTION 1. INSTALLATION, CONNECTORS, and CONTROLS..... | 1-1 |
| Installation..... | 1-1 |
| Unpacking..... | 1-1 |
| Selecting a Suitable Installation Site..... | 1-2 |
| Connectors..... | 1-3 |
| Controls | 1-5 |
| | |
| SECTION 2. GETTING STARTED..... | 2-1 |
| Ergonomic Features..... | 2-1 |
| Powering On the Terminal..... | 2-3 |
| Power ON..... | 2-3 |
| Observe the Following Sequence of Events..... | 2-3 |
| To Begin Using the Terminal..... | 2-3 |
| The Keyboard..... | 2-4 |
| Main Keyboard Keys..... | 2-5 |
| Function Keys..... | 2-5 |
| Auxiliary Keys..... | 2-7 |
| Setup Mode and the Setup Menus..... | 2-8 |
| The Setup Menus..... | 2-9 |
| Set 1 Setup Menu..... | 2-9 |
| Set 2 Setup Menu..... | 2-11 |
| Set 3 Setup Menu..... | 2-13 |
| Set 4 Setup Menu..... | 2-15 |
| Set 5 Setup Menu..... | 2-17 |
| Set 6 Setup Menu..... | 2-19 |
| Set 7 Setup Menu..... | 2-20 |
| Using the Status Line..... | 2-22 |
| | |
| APPENDIX | |
| A. Command Set Summary..... | A-1 |
| B. Programming the Function Keys and Cursor..... | B-1 |
| Arrow Keys | |
| C. Cursor Addressing..... | C-1 |
| D. Graphics Mode Character Sets..... | D-1 |
| E. ASCII Code Chart..... | E-1 |
| F. EIA and AUX Connector Pin Assignments..... | F-1 |

LIST OF ILLUSTRATIONS

| Figure | | Page |
|--------|--|------|
| 1-1 | Unpacking the Terminal..... | 1-1 |
| 1-2 | The Rear Panel of the Display Unit..... | 1-3 |
| 1-3 | Keyboard Connection to the Display Unit..... | 1-4 |
| 1-4 | Brightness Control..... | 1-5 |
| 2-1 | Display Unit Tilt and Swivel..... | 2-1 |
| 2-2 | Adjusting Keyboard Elevation..... | 2-2 |
| 2-3 | The Keyboard..... | 2-4 |
| 2-4 | The Set 1 Setup Menu..... | 2-9 |
| 2-5 | The Set 2 Setup Menu..... | 2-11 |
| 2-6 | The Set 3 Setup Menu..... | 2-13 |
| 2-7 | The Set 4 Setup Menu..... | 2-15 |
| 2-8 | The Set 5 Setup Menu..... | 2-17 |
| 2-9 | The Set 6 Setup Menu..... | 2-19 |
| 2-10 | The Set 7 Setup Menu..... | 2-20 |
| 2-11 | Status Line Parameters..... | 2-22 |

LIST OF TABLES

| Table | | Page |
|-------|--|------|
| 2-1 | Set 1 Setup Menu Parameter Blocks Description..... | 2-9 |
| 2-2 | Set 2 Setup Menu Parameter Blocks Description..... | 2-11 |
| 2-3 | Set 3 Setup Menu Parameter Blocks Description..... | 2-13 |
| 2-4 | Set 4 Setup Menu Parameter Blocks Description..... | 2-15 |
| 2-5 | Set 5 Setup Menu Parameter Blocks Description..... | 2-17 |
| 2-6 | Set 6 Setup Menu Parameter Blocks Description..... | 2-19 |
| 2-7 | Set 7 Setup Menu Parameter Blocks Description..... | 2-20 |
| 2-8 | Status Line Parameters Display Interpretation..... | 2-22 |

SECTION 1**INSTALLATION, CONNECTORS, and CONTROLS**

This section describes installation, connectors, and controls.

INSTALLATION**Unpacking**

Before unpacking the terminal, inspect the carton for any signs of damage. If damage to the carton is apparent, have the delivery agent note the damage on the shipping document. Note: Some shippers may wish to be present when the carton is opened, if external damage is apparent.

Unpack and inspect the terminal as follows: Refer to Figure 2-1.

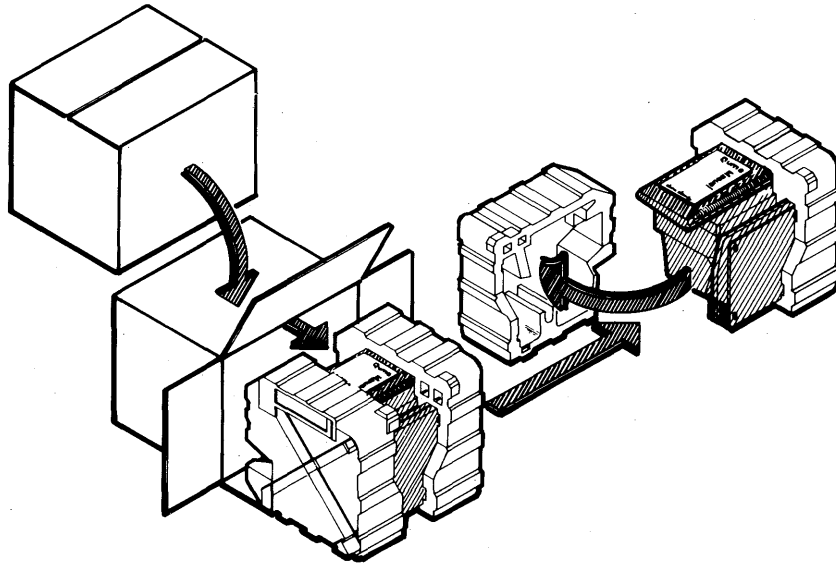

Figure 1-1. Unpacking the Terminal

1. Open the carton and place it on its side on a table top or flat working surface.
2. Slide the terminal with its Styrofoam packing buns from the carton.
3. Remove the packing buns, being careful not to jostle the keyboard or display unit. Do not allow either to fall.

INSTALLATION, CONNECTORS, and CONTROLS

4. Remove the plastic wrap from both the keyboard and the display unit.
5. Retain all packaging materials. When repacking the terminal for shipment, or to protect it during long storage periods, use only the original packaging materials.
6. Inspect both the keyboard and display unit for scratches, loose parts, and damage from rough handling. If there is evidence that any damage to the terminal might impair its proper operation, contact your service representative for advice and further instructions.

Selecting a Suitable Installation Site

To install your terminal, first select a suitable site.

A suitable site may be characterized as follows:

- A clean, well-lighted environment, with proper ventilation
- Convenient access to a power outlet with ground
- A stable platform to support the terminal at a comfortable height
- Adequate room for cable routing. Always use shielded cable

CONNECTORS

After a site has been selected and the terminal properly located, make the following connections.

At the rear of the display unit: Refer to Figure 1-2.

- Connect the host computer cable to the connector labeled **EIA** (refer to Appendix F for connector pin assignments).
- If a printer is available, connect it to the connector labeled **AUX** (refer to Appendix F for connector pin assignments).
- Verify that the **Power ON/OFF** switch is in the OFF position. Then connect the power cord to a grounded AC outlet. Power requirements of the terminal are: 120 VAC, 0.5 A, 45 W, and 60 Hz.

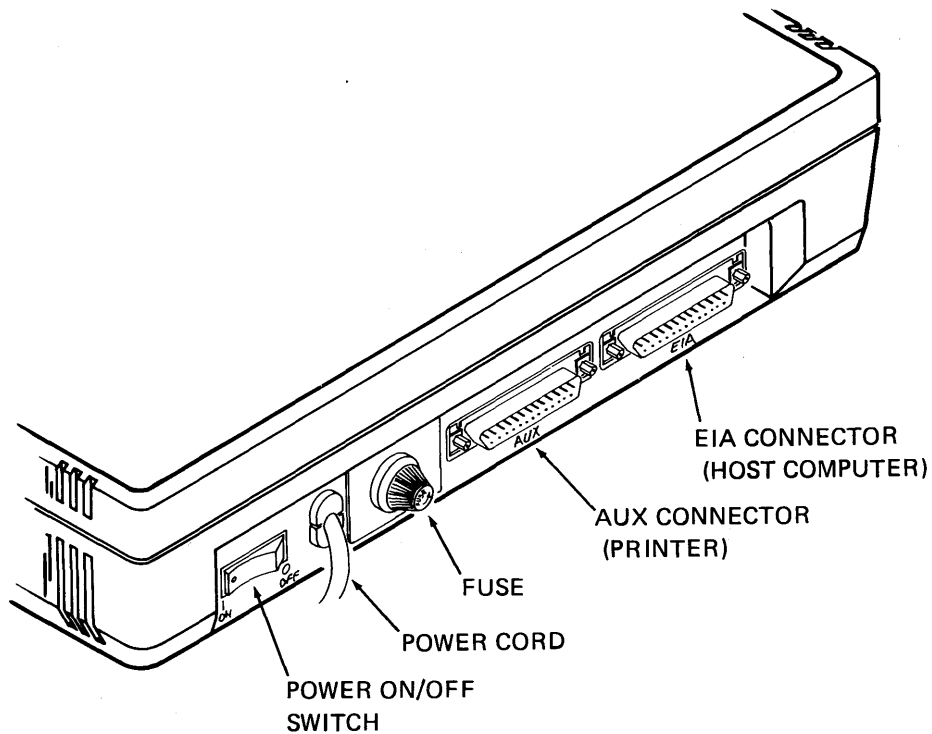

Figure 1-2. The Rear Panel of the Display Unit

INSTALLATION, CONNECTORS, and CONTROLS

At the left side of the display unit: Refer to Figure 1-3.

- Connect the keyboard to modular telephone style connector.

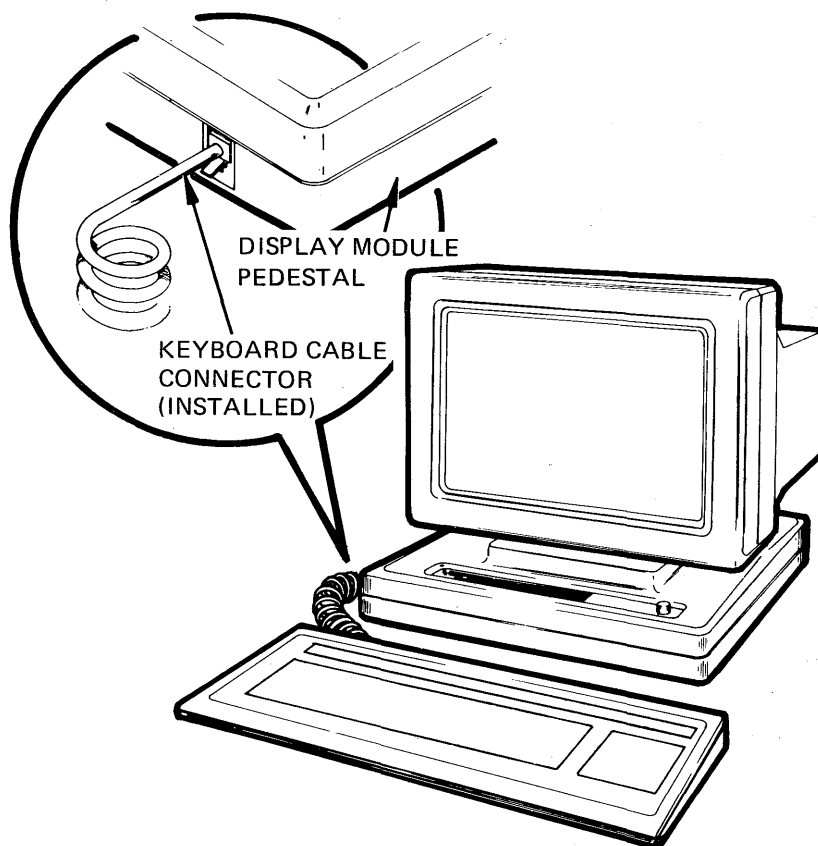

Figure 1-3. Keyboard Connection to the Display Unit

CONTROLS

Basic terminal controls are:

- Power ON/OFF The Power ON/OFF switch is a rocker type switch located on the rear panel (refer to Figure 1-2).
- Brightness The Brightness control is used to adjust display intensity. The rotating knob on the right front corner of the display unit is used for this purpose. Refer to Figure 1-4.

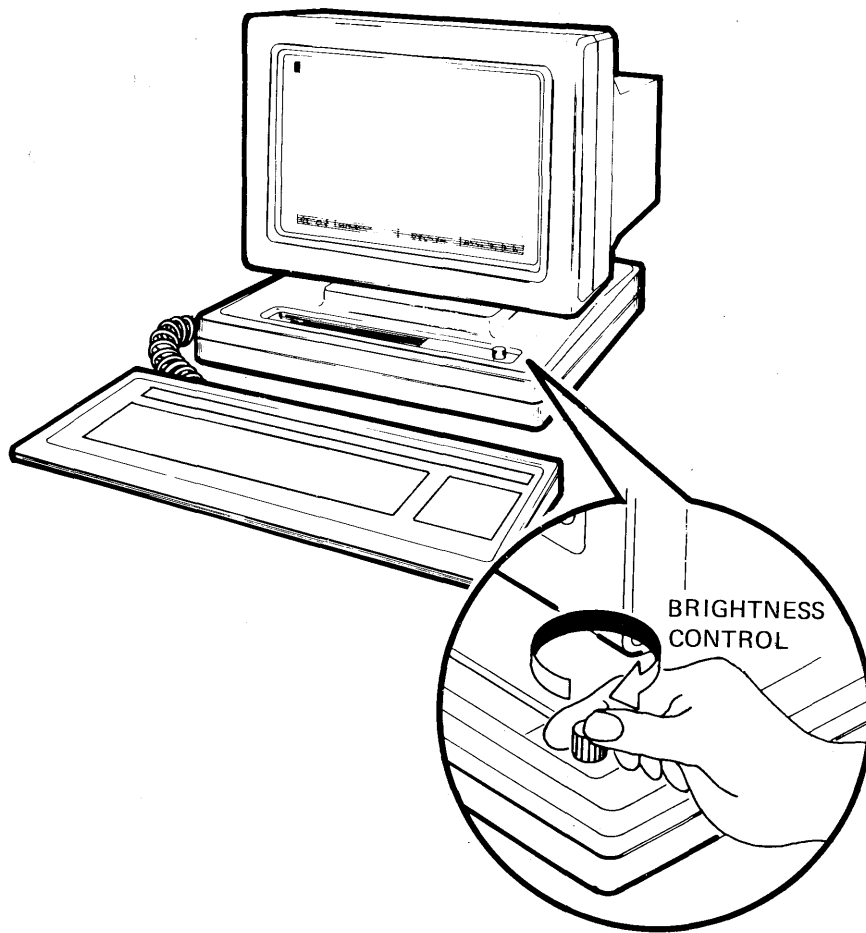

Figure 1-4. Brightness Control

SECTION 2**GETTING STARTED**

This section describes the ergonomic features of the terminal, powering On the terminal, the keyboard, setup mode, and using the status line.

ERGONOMIC FEATURES

The terminal features the following ergonomic design considerations for accommodating individual comfort.

Display Unit Tilt and Swivel. The display unit is ball mounted to its pedestal for easy rotation into an optimum viewing position. Refer to Figure 2-1.

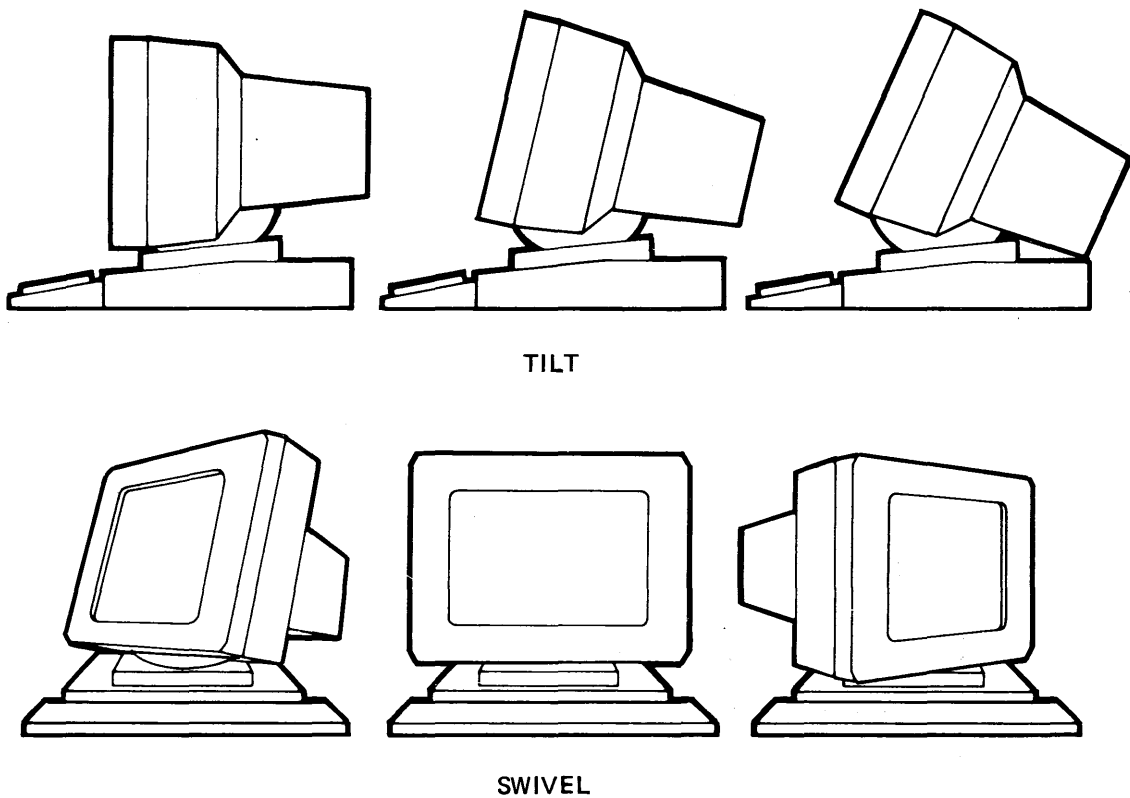

Figure 2-1. Display Unit Tilt and Swivel

GETTING STARTED

Keyboard Elevation. The keyboard is adjustable to any one of three elevations by rotating two recessed feet outward from the base. Refer to Figure 2-2.

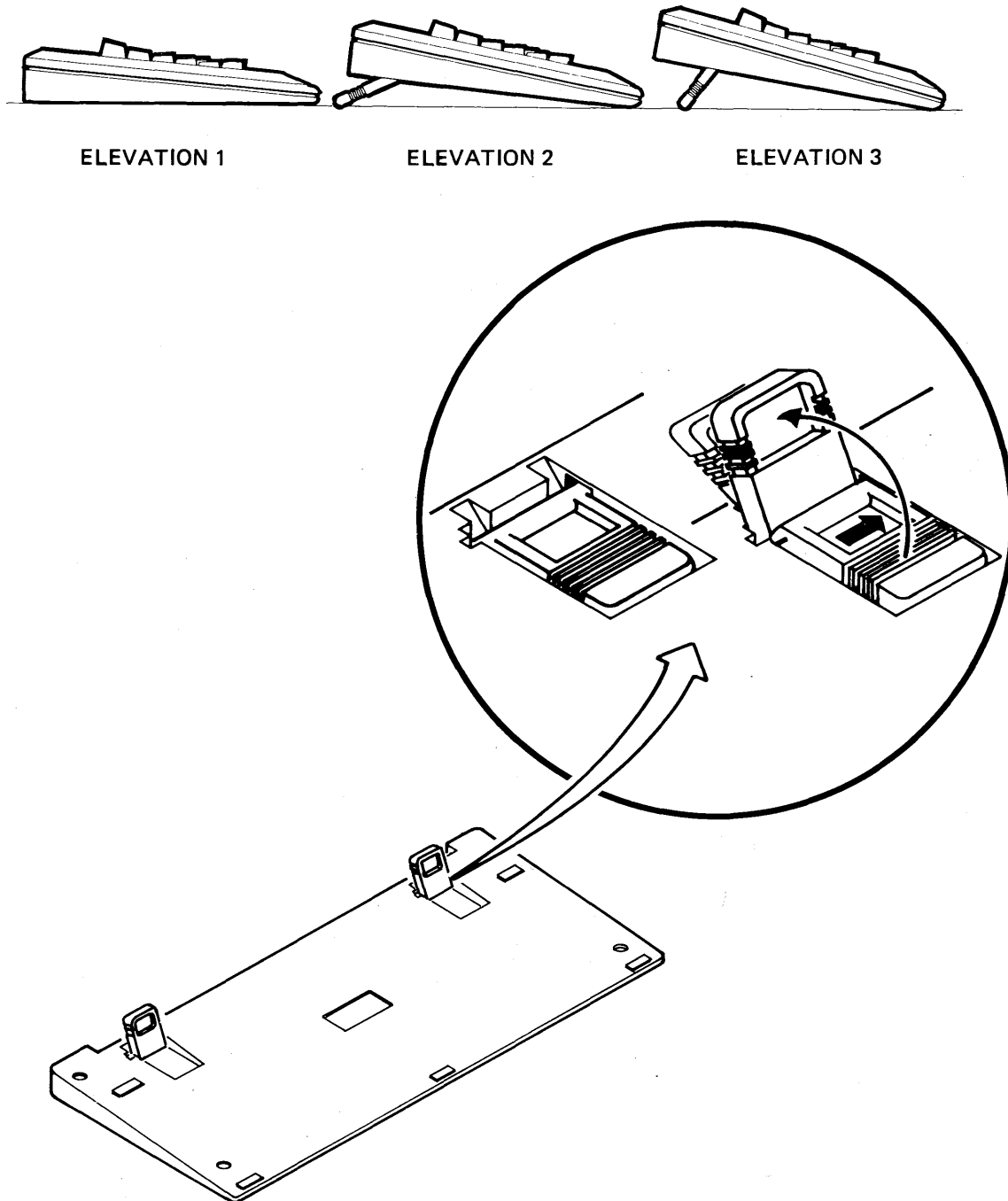

Figure 2-2. Adjusting Keyboard Elevation

POWERING ON THE TERMINAL

To power On the terminal and begin using it, proceed as follows:

Power ON

- Move the Power ON/OFF switch to the ON position (refer to Figure 1-2).

Observe the Following Sequence of Events

- The terminal beeps
- The Caps Lock indicator on the keyboard blinks
- Across the top of the screen display, note the Status Line and directly below on the next line, the blinking underline cursor. Refer to the paragraph **USING THE STATUS LINE** for a full explanation of the Status Line and its use.

To Begin Using the Terminal

Note: The terminal is now in On Line Mode; to use the terminal in a local application, it must be configured for Local Mode. Refer to the paragraph **SETUP MODE and the SETUP MENUS** for a full explanation about how to configure your terminal.

GETTING STARTED

THE KEYBOARD

The keyboard, illustrated in Figure 2-3, may be divided into the following functional groups:

- Main Keyboard Keys
- Function Keys
- Auxiliary Keys

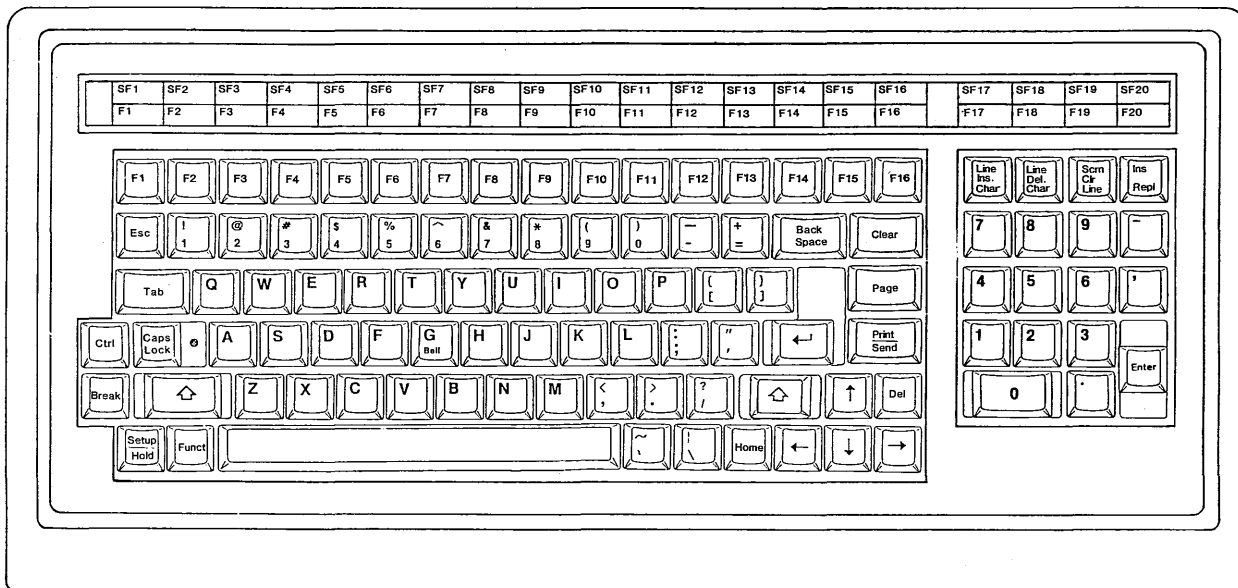

Figure 2-3. The Keyboard

Main Keyboard Keys

The Main Keyboard keys are the dark color keys in the large key cluster. Most of these keys function like those of any standard typewriter. However, some of the Main Keyboard keys are unique to the terminal, and these are described as follows:

| | |
|------------|---|
| Tab | Depressing the Tab key transmits the HT (Horizontal Tab) character to the host, and moves the cursor to the next tab stop. |
| Caps Lock | Capitals Lock. This key performs like a typewriter Shift Lock key, and causes the alpha keys to generate uppercase characters. When this feature is active the Caps Lock indicator light displays on the key top. |
| Back Space | Depressing the Back Space key transmits the BS (Back Space) character to the host, and moves the cursor one character position to the left. |
| Return | According to Setup Menu Number 3 selection, depressing the Return key causes either a carriage return, or a carriage return with line feed to be performed (the corresponding CR or CR + LF characters are sent to the host). |

Function Keys

The Function keys are the light color keys in the large key cluster.

| | |
|-------------|--|
| Esc | Escape. A special function key that is used to introduce an escape sequence. |
| Ctrl | Control. A special function key that is always used with another key to invoke a special control code. |
| Break | Depressing the Break key transmits a 200- to 250-millisecond space pulse to the host. |
| Set Up/Hold | Set Up / Hold Screen. This key may be used by itself to enable and disable the hold screen feature, or in combination with the Shift key to enter and exit Setup Mode. When the hold screen feature is enabled, all screen updating ceases until the feature is disabled. During this time the Hold Indicator in the Status Line displays. Setup Mode and the use of the Setup key is described in the paragraph SETUP MODE and the SETUP MENUS . |

Function Keys (Cont)

- Funcnt** Function. The Function key is a special application key that can be used to transmit a user-selected character bracketed by a start of header (SOH) code and a Carriage Return (CR) code. Also, in Setup Mode the Function key is used to initiate a Function key or Arrow key programming session.
- Clear** Depressing the Clear key erases all screen data and returns the cursor to the Home position.
- Page** Depressing the Page key, causes the terminal to display the next page in screen memory; depressing the Shift and Page keys causes the terminal to display the previous page in screen memory.
- Print/Send** Depressing the Send key causes data on the screen to be transmitted to the host; depressing the Print key (Shift - Print/Send) causes data on the screen to be output to the printer.
- Del** Delete. Depressing the Delete key transmits the ASCII DEL (delete) character to the host.
- Arrow Keys** The arrow keys control the movement of the cursor, by moving the cursor in the direction indicated by the arrow on the key top. The Arrow keys, like the Function keys, are programmable.
- Home** Depressing the Home key returns the cursor to the screen Home position, or Column 1, Line 1.
- F1 - F16** Top Row Function Keys. When pressed, these keys transmit to the host a user-selected ASCII character or a sequence of characters, bracketed by a Ctrl-A (SOH) code and a Carriage Return (CR) code. A Function key may be used by itself or in combination with the Shift key to generate a total of 40 code sequences. The Function keys and Arrow keys share 380 bytes of dynamically allocated memory; 255 bytes of this amount is the maximum capacity available to any one of these keys. Key contents are savable.

Use the Function Key Identifier Strip on the top edge of the keyboard to note the normal and shifted contents of keys F1 through F20.

Auxiliary Keys

The Auxiliary keys are those keys in the small key cluster.

Number Keys The number keys are used to enter numeric data in calculator fashion.

Enter According to Setup Menu selection, depressing the Enter key causes either a carriage return, or a carriage return with line feed to be performed (the corresponding CR or CR + LF characters are sent to the host). The Enter key is also used to temporarily store Function key and Arrow key contents, specified during programming sessions.

SETUP MODE and the SETUP MENUS

Setup Mode is used to tailor the operating parameters of the terminal to match the requirements of the system into which it is integrated.

To enter Setup Mode depress the Shift and Hold/Setup keys. Notice that a line displays on the last line of the screen; this is the Set 1 Setup Menu. In Setup Mode there are seven setup menus.

Each setup menu is separated into a series of parameter blocks. Each block contains all the possible values that may be assigned to that particular block.

To specify a parameter assignment, depress the cursor arrow keys to advance through the blocks of the setup menu. Observe that the block where a parameter assignment is to be made displays in Bold Reverse Video. To view the possible values within a parameter block, depress the Space Bar until the desired value displays, then move from the block by again depressing a cursor arrow key. Note, there are some parameter blocks, called Text Parameter Blocks, that are empty; into these you may enter text, as in the Here Is Block.

To save new Setup Mode parameters that have been selected from the setup menu lines, depress the Shift-S keys to write these values into memory. Should it ever be necessary to restore the Setup Mode parameters to their default values, depress the Shift-D keys; to restore these parameters to their previous values, depress the Shift-R keys. To terminate a Setup Mode session, depress the Hold/Setup key a second time (when exiting Setup Mode it is not necessary to depress the Shift key in combination with the Hold/Setup key).

The Setup Menus

Set 1 Setup Menu

The Set 1 Setup Menu is the first menu displayed after depressing the Shift and Setup keys to enter Setup Mode. This menu allows access to the other setup menus, by depressing the Down or Up Arrow keys to advance through the other setup menu lines. Figure 2-4 illustrates the Set 1 Setup Menu and Table 2-1 offers a description of the parameter blocks within this menu.

| | | | | | | | | |
|-------|------------|---------------|-------------------|--------------------|-------|----------------------------------|---------|-----------|
| SET 1 | FDX | CONV | 80 COL | EM:QVT 119 | KB ON | PRINT OFF | MON OFF | GRAPH OFF |
| | HDX LOC | MESG BLOCK | 132 COL 132 HS | WYSE 50 ADDS A2 | LOCK | COPY XCOPY BCOPY XBCOPY | ON | ON |

Figure 2-4. The Set 1 Setup Menu

Table 2-1. Set 1 Setup Menu Parameter Blocks Description

| PARAMETER BLOCK | DESCRIPTION |
|--------------------|---|
| TRANSMISSION MODE | <p>Possible Values: . (FDX) Full Duplex Mode (Default) . (HDX) Half Duplex Mode . (LOC) Local Mode</p> <p>Specifies the transmission mode in which the terminal communicates with the host system. In Full Duplex Mode, data from the terminal is processed to the host; unless the host echos this data, it can not be viewed on the display. Conversely, data processed in Half Duplex Mode is processed to both the host, and internally to the terminal display. In Local Mode, the terminal is OFF LINE, and does not communicate data with the host; data is only processed to the display.</p> |
| DATA TRANSMIT MODE | <p>Possible Values: . (CONV) Conversational Mode (Default) (MESG) Message Mode (BLOCK) Block Mode</p> <p>This parameter specifies the method of data transmission from the terminal to the host. In Conversational Mode, data is transmitted as it is entered on the keyboard; in Message Mode, the cursor line is transmitted when the Send key is pressed; in Block Mode, the entire screen is transmitted when the Send key is pressed.</p> |

Table 2-1. Set 1 Setup Menu Parameter Blocks Description (Cont)

| PARAMETER BLOCK | DESCRIPTION |
|------------------------------|---|
| COLUMN MODE | <p>Possible Values: . 80 Columns (Default) . 132 Columns . 132 HS (Horizontal Scroll)</p> <p>Specifies the number of columns displayed: 80 columns, 132 columns, or 80 columns out of a viewable 132 columns (QVT 119 and ADDS A2 Modes only; the display scrolls horizontally to keep the cursor in view).</p> |
| EMULATION MODE | <p>Possible Values: . QVT 119 (Default) . WYSE 50 . ADDS A2</p> <p>Specifies the command set emulation mode of the terminal: Native Mode (QVT 119), Wyse 50, or ADDS A2.</p> |
| KEYBOARD | <p>Possible Values: . ON (Default) . LOCK</p> <p>This feature can be used to disable the keyboard as a data entry device until a Keyboard Unlock command is received from the host, or one of the following key combinations pressed: Control-Shift-Setup/Setup, or Shift-Break.</p> |
| PRINTER INTERFACE (PRINT) | <p>Possible Values: . PRINT OFF (Default) . COPY . BCOPY . XCOPY . XBCOPY</p> <p>This feature is used to specify the operation of the Auxiliary or Printer port. When PRINT OFF is selected, the printer interface is disabled; COPY enables the Auxiliary port so that displayed data can be output to a printer; XCOPY, also enables the Auxiliary port, but causes all data processed for display to be copied to the Auxiliary port without being displayed; BCOPY, causes all data processed for display to be copied to the Auxiliary port, and allows data received on Pin 2 of the AUX connector to be transmitted to the host via the EIA connector; XBCOPY, causes all data processed for display to be copied to the Auxiliary port and not displayed, and allows all data received on Pin 2 of the AUX connector to be transmitted to the host via the EIA connector.</p> |

Table 2-1. Set 1 Setup Menu Parameter Blocks Description (Cont)

| PARAMETER BLOCK | DESCRIPTION |
|-----------------|--|
| MONITOR MODE | <p>Possible Values: . OFF (Default) . ON</p> <p>Monitor Mode is a feature that enables the display of all control codes and escape sequences in addition to the alphanumeric character set. Commands are only displayed and not interpreted when Monitor Mode is selected. For proper operation, the Line Wrap feature should also be enabled.</p> |
| GRAPHICS MODE | <p>Possible Values: . OFF (Default) . ON</p> <p>Graphics Mode is a special applications feature that reconfigures the normal keyboard character set to 15 thin-line graphics symbols and 64 block graphics symbols.</p> |

Set 2 Setup Menu

The Set 2 Setup Menu is illustrated in Figure 2-5; Table 2-2 offers a description of the parameter blocks within this menu.

| SET 2 | JUMP | REPEAT ON | CLICK ON | MARGIN BELL OFF | E.O.M.: | NUL |
|-------|--|-----------|----------|-----------------|---------|------------------|
| | SMOOTH 1, 2, 5, 10, 15, 30, or 60 | OFF | OFF | ON | | ETX EOT CR |

Figure 2-5. The Set 2 Setup Menu

Table 2-2. Set 2 Setup Menu Parameter Blocks Description

| PARAMETER BLOCK | DESCRIPTION |
|-----------------|--|
| SCROLL MODE | <p>Possible Values: . JUMP (Default) . SMOOTH 1, 2, 5, 10, 15, 30, or 60</p> <p>Specifies the method of scrolling data across the display: Jump Scroll or Incremental Smooth Scroll.</p> |

Table 2-2. Set 2 Setup Menu Parameter Blocks Description (Cont)

| PARAMETER BLOCK | DESCRIPTION |
|--------------------------|---|
| KEY REPEAT | <p>Possible Values: . ON (Default) . OFF</p> <p>Specifies whether or not the 30 character per second key repeat feature is enabled (ON) or disabled (OFF).</p> |
| KEY CLICK | <p>Possible Values: . ON (Default) . OFF</p> <p>Specifies whether or not the audible key click sound is generated when keys are pressed.</p> |
| MARGIN BELL | <p>Possible Values: . ON (Default) . OFF</p> <p>Specifies whether or not the margin bell sounds when the cursor passes through column 73 in 80 Column Mode, or column 124 in 132 Column Mode.</p> |
| END OF MESSAGE CHARACTER | <p>Possible Values: . NUL (Default) . ETX . EOT . CR</p> <p>Specifies the End of Message (E.O.M.) character used to terminate a transmission from the terminal to the host.</p> |

Set 3 Setup Menu

The Set 3 Setup Menu is illustrated in Figure 2-6; Table 2-3 offers a description of the parameter blocks within this menu.

| | | | | | |
|--------------|----------------------------|-------------------------|-------------------------|--|-------------------------------|
| SET 3 | LINE WRAP ON OFF | CR = CR CR,LF | SCROLL ON OFF | X-ON & DTR X-ON ONLY DTR ONLY NO HANDSHAKE | LIMITED XMIT OFF ON |
|--------------|----------------------------|-------------------------|-------------------------|--|-------------------------------|

Figure 2-6. The Set 3 Setup Menu

Table 2-3. Set 3 Setup Menu Parameter Blocks Description

| PARAMETER BLOCK | DESCRIPTION |
|------------------------------------|--|
| LINE WRAP MODE | Possible Values: . ON (Default) . OFF Specifies whether or not the cursor wraps around to the next line as the current line is completed, or if the screen scrolls as the current 24 line display is filled. |
| CARRIAGE RETURN/ LINE FEED MODE | Possible Values: . CR (Default) . CR + LF Specifies whether or not the receipt of a carriage return code implies a carriage return only, or a carriage return with line feed. |
| SCROLL MODE | Possible Values: . ON (Default) . OFF Specifies whether or not the screen display should automatically scroll. |

Table 2-3. Set 3 Setup Menu Parameter Blocks Description (Cont)

| PARAMETER BLOCK | DESCRIPTION |
|-----------------------|---|
| HANDSHAKE MODE | <p>Possible Values: . X-ON & DTR (Default) . X-ON ONLY . DTR ONLY . NO HANDSHAKE</p> <p>Specifies the kind of handshake protocol to be used to control communications: X-ON & DTR implies both X-ON/X-OFF and DTR protocol; X-ON ONLY, implies only X-ON/X-OFF protocol; DTR ONLY, implies only DTR protocol; and NO HANDSHAKE implies no communications control. Note: NO HANDSHAKE may be used to increase throughput, but only with Scroll Mode OFF and with a low baud rate.</p> |
| LIMITED TRANSMIT MODE | <p>Possible Values: . OFF (Default) . ON</p> <p>Specifies whether or not Limited Transmit Mode is enabled or disabled. Limited Transmit Mode ON has priority over baud rate, and acts to limit transmit speed to 100 to 120 character per second. This mode is used to minimize interrupts to the host.</p> |

Set 4 Setup Menu

The Set 4 Setup Menu is illustrated in Figure 2-7; Table 2-4 offers a description of the parameter blocks within this menu.

| | | | | | | | | |
|-------|----------|--------|--------|---------|---------|--------|---------------|--------------|
| SET 4 | EIA=HOST | 8 BITS | BIT8 0 | PAR OFF | PAR ODD | STOP 1 | RX BAUD: = TX | TX BAUD:9600 |
| | | 7 | 1 | ON | EVEN | 2 | 50 --> 38.4K | 50 --> 38.4K |

Figure 2-7. The Set 4 Setup Menu

Table 2-4. Set 4 Setup Menu Parameter Blocks Description

| PARAMETER BLOCK | DESCRIPTION |
|-------------------------|--|
| EIA PORT CONFIGURATION | Possible Values: . HOST (Default) . PRNT Configures the EIA Port as either the Host or Printer interface. |
| DATA BITS PER CHARACTER | Possible Values: . 8 Bits (Default) . 7 Bits Specifies the number of data bits used to encode ASCII characters as either 7 or 8 bits. |
| BIT 8 SET | Possible Values: . \emptyset (Default) . 1 When DATA BITS PER CHARACTER is set to 8, the BIT 8 SET parameter offers the option to set the eighth bit to either \emptyset or 1. |
| PARITY SELECT | Possible Values: . OFF (Default) . ON Configures the terminal to check (ON) or ignore (OFF) the parity bit of both received and transmitted data. |
| PARITY MODE | Possible Values: . ODD (Default) . EVEN When PARITY SELECT is set to ON, the PARITY MODE selection may be used to configure the terminal for either ODD or EVEN parity. |

Table 2-4. Set 4 Setup Menu Parameter Blocks Description (Cont)

| PARAMETER BLOCK | DESCRIPTION | | | | | | | | | | | | | | | | | | |
|--------------------|--|------|--------|------|--------|-------|--------|---------|--------|-------|--------|-------|---------|-------|---------|--------|--------------------|--------|--|
| STOP BITS | <p>Possible Values: . 1 (Default) . 2</p> <p>Configures ASCII encoded characters for one or two stop bits.</p> | | | | | | | | | | | | | | | | | | |
| RECEIVE BAUD RATE | <p>Possible Values: . TX (Default)</p> <table> <tr><td>. 50</td><td>. 2400</td></tr> <tr><td>. 75</td><td>. 3600</td></tr> <tr><td>. 110</td><td>. 4800</td></tr> <tr><td>. 134.5</td><td>. 7200</td></tr> <tr><td>. 150</td><td>. 9600</td></tr> <tr><td>. 300</td><td>. 19.2K</td></tr> <tr><td>. 600</td><td>. 38.4K</td></tr> <tr><td>. 1200</td><td>. Same as Transmit</td></tr> <tr><td>. 1800</td><td></td></tr> </table> <p>Specifies the baud rate for received data.</p> | . 50 | . 2400 | . 75 | . 3600 | . 110 | . 4800 | . 134.5 | . 7200 | . 150 | . 9600 | . 300 | . 19.2K | . 600 | . 38.4K | . 1200 | . Same as Transmit | . 1800 | |
| . 50 | . 2400 | | | | | | | | | | | | | | | | | | |
| . 75 | . 3600 | | | | | | | | | | | | | | | | | | |
| . 110 | . 4800 | | | | | | | | | | | | | | | | | | |
| . 134.5 | . 7200 | | | | | | | | | | | | | | | | | | |
| . 150 | . 9600 | | | | | | | | | | | | | | | | | | |
| . 300 | . 19.2K | | | | | | | | | | | | | | | | | | |
| . 600 | . 38.4K | | | | | | | | | | | | | | | | | | |
| . 1200 | . Same as Transmit | | | | | | | | | | | | | | | | | | |
| . 1800 | | | | | | | | | | | | | | | | | | | |
| TRANSMIT BAUD RATE | <p>Possible Values: . 9600 (Default)</p> <table> <tr><td>. 50</td><td>. 1800</td></tr> <tr><td>. 75</td><td>. 2400</td></tr> <tr><td>. 110</td><td>. 3600</td></tr> <tr><td>. 134.5</td><td>. 4800</td></tr> <tr><td>. 150</td><td>. 7200</td></tr> <tr><td>. 300</td><td>. 19.2K</td></tr> <tr><td>. 600</td><td>. 38.4K</td></tr> <tr><td>. 1200</td><td></td></tr> </table> <p>Specifies the baud rate for transmitted data.</p> | . 50 | . 1800 | . 75 | . 2400 | . 110 | . 3600 | . 134.5 | . 4800 | . 150 | . 7200 | . 300 | . 19.2K | . 600 | . 38.4K | . 1200 | | | |
| . 50 | . 1800 | | | | | | | | | | | | | | | | | | |
| . 75 | . 2400 | | | | | | | | | | | | | | | | | | |
| . 110 | . 3600 | | | | | | | | | | | | | | | | | | |
| . 134.5 | . 4800 | | | | | | | | | | | | | | | | | | |
| . 150 | . 7200 | | | | | | | | | | | | | | | | | | |
| . 300 | . 19.2K | | | | | | | | | | | | | | | | | | |
| . 600 | . 38.4K | | | | | | | | | | | | | | | | | | |
| . 1200 | | | | | | | | | | | | | | | | | | | |

Set 5 Setup Menu

The Set 5 Setup Menu is illustrated in Figure 2-8; Table 2-5 offers a description of the parameter blocks within this menu.

| | | | | | | | |
|-------|----------|--------|--------|------------|------------|--------|--------------------|
| SET 5 | AUX=PRNT | 8 BITS | BIT8 0 | PARITY OFF | PARITY ODD | STOP 1 | RX & TX BAUD: 9600 |
| | | 7 | 1 | ON | EVEN | 2 | 50 --> 38.4K |

Figure 2-8. The Set 5 Setup Menu

Table 2-5. Set 5 Setup Menu Parameter Blocks Description

| PARAMETER BLOCK | DESCRIPTION |
|-------------------------|---|
| AUX PORT CONFIGURATION | Possible Values: . PRNT (Default) . HOST Configures the AUX Port as either the Printer or Host interface. |
| DATA BITS PER CHARACTER | Possible Values: . 8 Bits (Default) . 7 Bits Specifies the number of data bits used to encode ASCII characters as either 7 or 8 bits. |
| BIT 8 SET | Possible Values: . 0 (Default) . 1 When DATA BITS PER CHARACTER is set to 8, the BIT 8 SET parameter offers the option to set the eighth bit to either 0 or 1. |
| PARITY SELECT | Possible Values: . OFF (Default) . ON Configures the terminal to check (ON) or ignore (OFF) the parity bit of both received and transmitted data. |
| PARITY MODE | Possible Values: . ODD (Default) . EVEN When PARITY SELECT is set to ON, the PARITY MODE selection may be used to configure the terminal for either ODD or EVEN parity. |

Table 2-5. Set 5 Setup Menu Parameter Blocks Description (Cont)

| PARAMETER BLOCK | DESCRIPTION | | | | | | | | | | | | | | | | |
|-----------------------------------|--|------|--------|------|--------|-------|--------|---------|--------|-------|--------|-------|---------|-------|---------|--------|--|
| STOP BITS | <p>Possible Values: . 1 (Default) . 2</p> <p>Configures ASCII encoded characters for one or two stop bits.</p> | | | | | | | | | | | | | | | | |
| RECEIVE AND TRANSMIT BAUD RATE | <p>Possible Values: . 9600 (Default)</p> <table> <tr> <td>. 50</td> <td>. 1800</td> </tr> <tr> <td>. 75</td> <td>. 2400</td> </tr> <tr> <td>. 110</td> <td>. 3600</td> </tr> <tr> <td>. 134.5</td> <td>. 4800</td> </tr> <tr> <td>. 150</td> <td>. 7200</td> </tr> <tr> <td>. 300</td> <td>. 19.2K</td> </tr> <tr> <td>. 600</td> <td>. 38.4K</td> </tr> <tr> <td>. 1200</td> <td></td> </tr> </table> <p>Specifies the baud rate for both received data and transmitted data.</p> | . 50 | . 1800 | . 75 | . 2400 | . 110 | . 3600 | . 134.5 | . 4800 | . 150 | . 7200 | . 300 | . 19.2K | . 600 | . 38.4K | . 1200 | |
| . 50 | . 1800 | | | | | | | | | | | | | | | | |
| . 75 | . 2400 | | | | | | | | | | | | | | | | |
| . 110 | . 3600 | | | | | | | | | | | | | | | | |
| . 134.5 | . 4800 | | | | | | | | | | | | | | | | |
| . 150 | . 7200 | | | | | | | | | | | | | | | | |
| . 300 | . 19.2K | | | | | | | | | | | | | | | | |
| . 600 | . 38.4K | | | | | | | | | | | | | | | | |
| . 1200 | | | | | | | | | | | | | | | | | |

Set 6 Setup Menu

The Set 6 Setup Menu is illustrated in Figure 2-9; Table 2-6 offers a description of the parameter blocks within this menu.

| SET 6 | PAGE MODE | STD VID | RET/ENTER = CR / CR | PROT = DIM | DISPLAY PE ON |
|-------|-----------|---------|---------------------|-------------|---------------|
| | SPLIT | REV | CRLF/TAB | REV NORM | OFF |

Figure 2-9. The Set 6 Setup Menu

Table 2-6. Set 6 Setup Menu Parameter Blocks Description

| PARAMETER BLOCK | DESCRIPTION |
|---------------------------|---|
| PAGE/SPLIT MODE | <p>Possible Values: . PAGE MODE (Default) . SPLIT MODE</p> <p>Specifies the interpretation of the Page key and the Next Page/Previous Page commands; that is, in PAGE MODE, the appropriate page is caused to display, in SPLIT MODE, the cursor is moved into the next segment if segments have been defined.</p> |
| VIDEO | <p>Possible Values: . STANDARD (Default) . REVERSE</p> <p>Specifies the display presentation of light characters on a dark background (STANDARD), or dark characters on a light background (REVERSE).</p> |
| RETURN / ENTER | <p>Possible Values: . CR / CR (Default) . CRLF / TAB</p> <p>Specifies the interpretation of the Return and Enter keys. When CR/CR is selected, pressing either the Return or Enter key, implies that a carriage return is to be performed. When CRLF/TAB is selected, pressing the Return key implies a carriage return with line feed; pressing the Enter key implies a forward tab.</p> |
| PROTECT MODE ATTRIBUTE | <p>Possible Values: . DIM (Default) . REV . NORM</p> <p>Specifies the display attribute of protected areas as NORMAL, DIM (reduced intensity), or REVERSE.</p> |

Table 2-6. Set 6 Setup Menu Parameter Blocks Description (Cont)

| PARAMETER BLOCK | DESCRIPTION |
|----------------------------------|---|
| PARITY ERROR DETECT CHARACTER | Possible Values: . OFF (Default) . ON Specifies whether or not the Parity Error Detect Character is to be displayed or ignored. |

Set 7 Setup Menu Line

The Set 7 Setup Menu is illustrated in Figure 2-10; Table 2-7 describes the parameter blocks within this menu.

| | | | | | | |
|-------|---------|--------------|---------|--------|-----------|---------|
| SET 7 | CURSOR: | UL BLINK | TIME 15 | KB: US | STATUS ON | FREQ 60 |
| | | BLOCK STEADY | 1 | UK | OFF | 50 |
| | | BLOCK BLINK | 5 | GM | | |
| | | UL STEADY | OFF | SP | | |
| | | | | FR | | |

Figure 2-10. The Set 7 Setup Menu

Table 2-7. Set 7 Setup Menu Parameter Blocks Description

| PARAMETER BLOCK | DESCRIPTION |
|------------------|---|
| CURSOR ATTRIBUTE | Possible Values: . UL BLINK (Default) . BLOCK STEADY . BLOCK BLINK . UL STEADY Specifies the display attribute of the cursor as either a steady or blinking underline or block. |

Table 2-7. Set 7 Setup Menu Parameter Blocks Description (Cont)

| PARAMETER BLOCK | DESCRIPTION |
|-----------------|--|
| TIME | <p>Possible Values: . 15 (Default) . 1 . 5 . OFF</p> <p>Specifies whether or not the screen-saver feature is active. This feature automatically blanks the display for 1, 5, or 15 minutes to preserve the screen phosphor during periods when the terminal is idle. Upon receipt of new data, the screen display is restored. This feature may be defeated by selecting OFF.</p> |
| KEYBOARD TYPE | <p>Possible Values: . US (Default) . UK . GM . SP . FR</p> <p>Specifies the active keyboard character set as United States, United Kingdom, German, Spanish, or French.</p> |
| STATUS | <p>Possible Values: . ON (Default) . OFF</p> <p>Specifies whether or not the setup lines are displayed or blanked.</p> |
| FREQUENCY | <p>Possible Values: . 60 (Default) . 50</p> <p>Electrically configures the terminal for use with either a 60 or 50 Hz power source to eliminate screen flicker.</p> |

USING THE STATUS LINE

The Status Line is the top line on the display. It serves as a reference line to note the status of the terminal's more common operating parameters. Figure 2-11 illustrates the Status Line and Table 2-8 describes these parameters.

| | | HDX | Q119 | | | 9600 | P 1-01-001 | | |
|------|-----|-----|-------|-----|------|--------|------------|-------|-------------|
| LOCK | MON | BLK | PROT | INS | WY50 | COPY | GRAPH | 50 | BUSY *THP S |
| | | FDX | *PROT | | ADDS | XCOPY | | thru | |
| | | LOC | | | | BCOPY | | 38.4K | |
| | | | | | | XBCOPY | | | |
| | | | | | | PRINT | | | |

Figure 2-11. Status Line Parameters

Table 2-8. Status Line Parameters Display Interpretation

| STATUS LINE PARAMETER | DISPLAY INTERPRETATION |
|-----------------------|---|
| KEYBOARD LOCK MODE | Blank (Default) = Keyboard enabled. LOCK = Keyboard disabled |
| MONITOR MODE | Blank (Default) = Monitor Mode not selected. MON = Monitor Mode selected. |
| TRANSMISSION MODE | HDX (Default) = Half Duplex Mode. BLK = Block Mode. FDX = Full Duplex Mode. LOC = Local Mode. |
| PROTECT MODE | Blank (Default) = Protect Mode not selected. PROT = Protect Mode selected. *PROT = Protect Mode with Write Protect selected. |
| INSERT MODE | Blank (Default) = Insert Mode not selected. INS = Insert Mode selected. |
| EMULATION MODE | Q119 (Default) = QVT 119 Mode. WT50 = Wyse 50 Emulation Mode. ADDS = ADDS A2 Emulation Mode. |
| AUXILIARY PORT MODE | Blank (Default) = Printer interface disabled. COPY = Printer interface enabled. XCOPY = Transparent Mode selected. BCOPY = Bidirectional Mode selected. XBCOPY = Bidirectional Transparent Mode selected. |
| GRAPHICS MODE | Blank (Default) = Graphics Mode not selected. GRAPH = Graphics Mode selected. |

Table 2-8. Status Line Parameters Display Interpretation (Cont)

| STATUS LINE PARAMETER | DISPLAY INTERPRETATION |
|-----------------------|--|
| RECEIVE BAUD RATE | 9600 (Default) = 9600 baud (EIA Port). 15 Possible: 50, 75, 110, 134.5, 150, 300, 600, 1200, 1800, 2400, 3600, 4800, 7200, 19.2K, or 38.4K. |
| BUSY STATUS | Blank (Default) = Terminal/Host/Printer ready. T = Terminal busy. *T = Hold key depressed; Terminal busy. H = Host busy. P = Printer busy. |
| CURSOR POSITION | P/S 1-01-001 (Default) = Cursor position in Page-Row- Column coordinates. P (Up Arrow) = Page Mode; cursor position in top segment or page. P (Down Arrow) = Page Mode; cursor position in bottom segment. S (Up Arrow) = Split Mode; cursor position in top segment. S (Down Arrow) = Split Mode; cursor position in bottom segment. |

APPENDIX A. COMMAND SET SUMMARY

| COMMAND | QVT 119 | ADDS A2 | WY-50 |
|----------------|--------------------------------------|----------------------------|----------------------------|
| CURSOR | | | |
| Home | CTRL- ^ HOME | CTRL- ^ HOME | CTRL- ^ HOME ESC { |
| Right | CTRL-L --> SHIFT/BS | CTRL-F --> | CTRL-L --> |
| Left | CTRL-H <-- BACKSPACE | CTRL-H <-- BACKSPACE | CTRL-H <-- BACKSPACE |
| Up | CTRL-K UP ARROW | CTRL-Z UP ARROW | CTRL-K UP ARROW |
| Move Up Scroll | | | ESC j |
| Down | CTRL-J | CTRL-J | CTRL-J |
| Return | CTRL-M RETURN ENTER | CTRL-M RETURN ENTER | CTRL-M RETURN ENTER |
| New Line | CTRL- <u> </u> | | CTRL- <u> </u> RETURN |
| Backspace | CTRL-H | CTRL-H | CTRL-H |
| TAB | | | |
| Set Tab | ESC 1 | [ESC 1] | ESC 1 |
| Clear Tab | ESC 2 | [ESC 2] | ESC 2 |
| Clear All Tabs | ESC 3 | | ESC 0 |
| Column Tab | CTRL-I TAB | | ESC-i |
| Field Tab | CTRL-I (Protect Mode only) TAB | | |
| Back Tab | ESC I SHIFT/TAB | [ESC I] | ESC I |

Note: Commands in "[]"s are QVT 119 commands honored in other emulations.

APPENDIX A. COMMAND SET SUMMARY (Cont)

| COMMAND | QVT 119 | ADDS A2 | WY-50 |
|---|-----------------------|---------------------|-----------------|
| EDIT | | | |
| Character Insert | ESC Q | [ESC Q] | ESC Q |
| Character Delete | ESC W | [ESC W] | ESC W |
| Line Insert | ESC E | [ESC E] | ESC E |
| Line Delete | ESC R | [ESC R] | ESC R |
| Clear from Cursor to end of line with spaces (or to protected when PROT is ON WY-50 Mode Only). | ESC T | ESC K or [ESC T] | ESC T |
| Clear from Cursor to end of line with nulls (or to protected when PROT is on WY-50 Mode only). | ESC t | [ESC t] | ESC t |
| Clear from Cursor to end of screen with spaces (unpro- tected only when PROT is on WY-50 Mode only) | ESC Y | | ESC Y |
| Clear from Cursor to end of screen/ segment with nulls (unprotected only when PROT is on WY-50 only) | ESC y | [ESC y] | ESC y |
| Clear all to Nulls | ESC *0 | [ESC *0] | ESC * |
| Clear all to Spaces | ESC *1 | [ESC *1] | ESC + |
| Clear Unprotected to Nulls | ESC *2 | [ESC *2] | ESC : |
| Clear Screen | CTRL-Z SHIFT/CLEAR | CTRL-L | |
| Clear Unprotected to spaces | ESC *3 | [ESC *3] | CTRL-Z ESC ; |
| Clear Unprotected to Attributes | | | ESC !<Attr> |
| Clear Unprotected with Codes | ESC ** <char> | ESC ** <char> | ESC .<code> |

Note: Commands in "[]"s are QVT 119 commands honored in other emulations.

APPENDIX A. COMMAND SET SUMMARY (Cont)

| COMMAND | QVT 119 | ADDS A2 | WY-50 |
|----------------------------|---------|--------------|--------|
| VIDEO ATTRIBUTES | | | |
| Set Tag Bit | | CTRL-N | |
| Reset Tag Bit | | CTRL-O | |
| Screen Attributes | | | |
| Cursor Visible | ESC .0 | CTRL-X | ESC `0 |
| Cursor Invisible | ESC .0 | CTRL-W | ESC `1 |
| Cursor Blinking Block | ESC .1 | [ESC .1] | ESC `5 |
| Cursor Steady Block | ESC .2 | [ESC .2] | ESC `2 |
| Cursor Blinking Underline | ESC .3 | [ESC .3] | ESC `3 |
| Cursor Steady Underline | ESC .4 | [ESC .4] | ESC `4 |
| Normal Protect Character | ESC .8 | [ESC .8] | ESC `A |
| Reverse Protect Character | ESC .9 | [ESC .9] | ESC `6 |
| Dim Protect Character | ESC .: | [ESC .:] | ESC `7 |
| Screen Display OFF | ESC n 2 | [ESC n 2] | ESC `8 |
| Screen Display ON | ESC n 3 | [ESC n 3] | ESC `9 |
| 80-column Mode | ESC n 4 | [ESC n 4] | ESC `: |
| 132-column Mode | ESC n 5 | [ESC n 5] | ESC `; |
| 132-Horizontal Scroll Mode | ESC n 6 | [ESC n 6] | |
| Jump Scroll | ESC n 8 | [ESC n 8] or | |
| | ESC j | [ESC j] | ESC `@ |
| Smooth Scroll 1 | ESC n 9 | [ESC n 9] | ESC `< |
| Smooth Scroll 2 | ESC n : | [ESC n :] | ESC `= |
| Smooth Scroll 5 | ESC n ; | [ESC n ;] | ESC `> |
| Smooth Scroll 10 | ESC n < | [ESC n <] | ESC `? |
| | ESC s | [ESC s] | |
| Smooth Scroll 15 | ESC n = | [ESC n =] | |
| Smooth Scroll 30 | ESC n > | [ESC n >] | |
| Smooth Scroll 60 | ESC n ? | [ESC n ?] | |
| Reverse Video | ESC j | [ESC j] | |
| Reverse Video | ESC n 0 | [ESC n 0] | |
| Normal Video | ESC n 1 | [ESC n/1] | |

Note: Commands in "[]"s are QVT 119 commands honored in other emulations.

APPENDIX A. COMMAND SET SUMMARY (Cont)

| COMMAND | QVT 119 | ADDS A2 | WY-50 |
|-------------------------------------|----------|-----------------------|---------|
| VIDEO ATTRIBUTES (Cont) | | | |
| Character/Display Attributes | | | |
| Normal Video: | | | |
| Full Intensity | ESC G 0 | ESC G @ [ESC G 0] | ESC G 0 |
| Half Intensity | ESC G sp | ESC 0 A [ESC g sp] | ESC G p |
| Invisible Normal Video: | | | |
| Full Intensity | ESC G 1 | ESC 0 D | ESC G 1 |
| Half Intensity | ESC G ! | [ESC G !] | ESC G q |
| Blink: | | | |
| Full Intensity | ESC G 2 | ESC 0 B | ESC G 2 |
| Half Intensity | ESC G " | ESC 0 C | ESC G r |
| Invisible Blink: | | | |
| Full Intensity | ESC G 3 | [ESC G 3] | ESC G 3 |
| Half Intensity | ESC G # | [ESC G #] | ESC G s |
| Reverse Current Background | | | |
| Full Intensity | ESC G 4 | ESC 0 P [ESC G 4] | ESC G 4 |
| Half Intensity | ESC G \$ | ESC 0 0 [ESC G \$] | ESC G t |
| Invisible Reverse: | | | |
| Full Intensity | ESC G 5 | [ESC G 5] | ESC G 5 |
| Half Intensity | ESC G % | [ESC G %] | ESC G u |
| Reverse and Blink: | | | |
| Full Intensity | ESC G 6 | ESC 0 R [ESC G 6] | ESC G 6 |
| Half Intensity | ESC G & | ESC 0 S [ESC G &] | ESC G v |
| Invisible Reverse and Blink: | | | |
| Full Intensity | ESC G 7 | [ESC G 7] | ESC G 7 |
| Half Intensity | ESC G ^ | [ESC G ^] | ESC G w |

Note: Commands in "[]"s are QVT 119 commands honored in other emulations.

APPENDIX A. COMMAND SET SUMMARY (Cont)

| COMMAND | QVT 119 | ADDS A2 | WY-50 |
|---|---------|----------------------|-----------|
| VIDEO ATTRIBUTES (Cont) | | | |
| Character/Display Attributes | | | |
| Underline: | | | |
| Full Intensity | ESC G 8 | ESC O / | ESC G 8 |
| Half Intensity | ESC G (| ESC O a | ESC G x |
| Invisible Underline: | | | |
| Full Intensity | ESC G 9 | [ESC G 9] | ESC G 9 |
| Half Intensity | ESC G) | [ESC G)] | ESC G y |
| Underline and Blink: | | | |
| Full Intensity | ESC G : | ESC O b [ESC G :] | ESC G : |
| Half Intensity | ESD G * | ESC O c [ESC G *] | ESC G z |
| Invisible Underline and Blink: | | | |
| Full Intensity | ESC G ; | [ESC G ;] | ESC G ; |
| Half Intensity | ESC G + | [ESC G +] | ESC G |
| Reverse and Underline: | | | |
| Full Intensity | ESC G < | [ESC G <] | ESC G < |
| Half Intensity | ESC G , | [ESC G ,] | ESC G |
| Invisible Reverse and Underline: | | | |
| Full Intensity | ESC G = | [ESC G =] | ESC G = |
| Half Intensity | ESC G - | [ESC G -] | ESC G - |
| Reverse, Underline and Blink: | | | |
| Full Intensity | ESC G > | [ESC G >] | ESC G > |
| Half Intensity | ESC G . | [ESC G .] | ESC ~ |
| Invisible Reverse, Underline and Blink: | | | |
| Full Intensity | ESC G ? | [ESC G ?] | ESC G ? |
| Half Intensity | ESC G / | [ESC G /] | ESC G DEL |
| Line Attributes | | | |
| Single High/Wide | ESC I 5 | | |
| Double Wide | ESC I 6 | | |
| Double High/Wide | ESC I 7 | | |
| Double High Tops | ESC I 3 | | |
| Double High Bottoms | ESC I 4 | | |

Note: Commands in "[]"s are QVT 119 commands honored in other emulations.

APPENDIX A. COMMAND SET SUMMARY (Cont)

| COMMAND | QVT 119 | ADDS A2 | WY-50 |
|---|--|--|---------------------------|
| PROGRAM | | | |
| Keyboard Disable | ESC # | ESC 5 or CTRL-D [ESC #] | CTRL-0 ESC # |
| Keyboard Enable | ESC " CTRL-SHIFT/ BREAK SHIFT/BREAK | ESC 6 CTRL-B CTRL/BREAK [ESC "] | ESC " CTRL- N SETUP |
| Address Cursor (80-Column) | ESC = Line # Col # | ESC Y Line # Col # [ESC=Line # Col #] | ESC = Line # Col # |
| Address Cursor (132-Column) | ESC=Line # Col # | [ESC=Line # Col #] | ESC a<rrRcccc> |
| Read Cursor (80-Column) | ESC ? | [ESC ?] | ESC ? |
| Read Cursor (132-Column) | ESC ? | [ESC ?] | ESC ? |
| Address Cursor Page Read Cursor Page | ESC-<PRC> ESC / | [ESC <PRC>] [ESC /] | ESC=<PRC> ESC / |
| Load Cursor Line | ESC [Line # | CTRL-K Line# | ESC [Line # |
| Load Cursor (80/132-Column) | ESC] Col # | CTRL-P Line# or [ESC] Col #] | ESC] Line # |
| Enter Graphic Character | | | ESC H<x> |
| Graphics Mode Enable | ESC \$ | [ESC \$] | ESC H CTRL-B |
| Graphics Mode Disable | ESC % | [ESC %] | ESC H CTRL-C |
| Monitor Mode Enable | ESC U CTRL-1* | CTRL-1 | ESC U CTRL-1* |
| Monitor Mode Disable | ESC X ESC u CTRL-1* | CTRL-2 | ESC X, SHIFT CTRL-1* |
| Protect Mode Enable | ESC & | [ESC &] | ESC & |
| Protect Mode Disable | ESC ' | [ESC '] | ESC ' |

* = "1" issued from the Numeric Keypad.

Note: Commands in "[]"s are QVT 119 commands honored in other emulations.

APPENDIX A. COMMAND SET SUMMARY (Cont)

| COMMAND | QVT 119 | ADDS A2 | WY-50 |
|---|---------------------------------|-------------------------------------|-------------------------------------|
| PROGRAM (Cont) | | | |
| Write Protect Mode ON | ESC) | [ESC)] | ESC) |
| Write Protect Mode OFF | ESC (| [ESC (] | ESC (|
| Auto Scroll ON | ESC H | [ESC H] | ESC O |
| Auto Scroll OFF | ESC H | [ESC H] | ESC N |
| Scroll Faster | SHIFT/CTRL Up Arrow | SHIFT/CTRL Up Arrow | SHIFT/CTRL Up Arrow |
| Scroll Slower | SHIFT/CTRL Down Arrow | SHIFT/CTRL Down Arrow | SHIFT/CTRL Down Arrow |
| Conversational Mode Enable | ESC C | [ESC C] | ESC C SHIFT/Break |
| Message Mode Enable | ESC D | [ESC D] | ESC D |
| Block Mode Enable | ESC B | [ESC B] | ESC B SHIFT/Break |
| Program Send Delimiter | ESC x N | [ESC x N] | |
| Display Select Control Character | ESC F N | ESC F N | |
| Ring Bell | CTRL-G | CTRL-G | CTRL-G |
| Load Top User Line | ESC Z data CR | [ESC Z data CR] | ESC F <dataCR> CR] |
| Load Bottom User Line | ESC f data CR | [ESC f data CR] | ESC f data CR |
| Display Bottom User/ Line/Function Key | ESC g | [ESC g] | |
| Display Bottom User/ Line/Function Key | ESC h | [ESC h] | |
| Request Unused Function Key Buffer Size | ESC > | [ESC >] | |
| Emulation Override Code | ESC DEL Q1 | ESC DEL A2 | ESC DEL W1 |
| Return Current Emu- lation | ESC DEL *E | [ESC DEL *E] | [ECS DEL *E] |
| Return Emulation List Select Emulation | ESC DEL *L ESC DEL Q1 DEL | [ESC DEL *L] [ESC DEL A2 DEL] | [ESC DEL *L] [ESC DEL W1 DEL] |

Note: Commands in "[]"s are QVT 119 commands honored in other emulations.

APPENDIX A. COMMAND SET SUMMARY (Cont)

| COMMAND | QVT 119 | ADDS A2 | WY-50 |
|--|------------------------------|--------------------------------|-------------------------------|
| PRINT | | | |
| Copy Mode ON | ESC @ | CTRL-R | CTRL-R SHIFT/CTRL Print |
| Print Mode OFF | ESC A | CTRL-T | CTRL-T SHIFT CTRL-Print |
| XCopy Mode ON | CTRL-R | ESC 3 | CTRL-X |
| XCopy Mode OFF | CTRL-T | ESC 4 | CTRL-T |
| Disable | | | SHIFT/PRINT/ SETUP |
| BCopy Mode ON | ESC ` | | |
| XBCopy Mode ON | ESC | | |
| Print from top of Screen to Cursor* | ESC N SHIFT/PRINT | [ESC N] SHIFT/PRINT | |
| Print from Cursor to End of Screen* | ESC O CTRL SHIFT/PRINT | CTRL/PRINT | |
| Print Unprotected* | | | ESC @ |
| Print Entire Screen* | ESC P SHIFT/PRINT | [ESC P] PRINT | ESC P PRINT |
| Print all Unfor- matted* | | | ESC L ESC p |
| Print Line* | ESC M CTRL-SHIFT PRINT | [ESC M] CTRL-SHIFT PRINT | |
| SEND FUNCTIONS | | | |
| Send Character | | | ESC M |
| Send Line (Unprotected Only) | ESC 4 | [ESC 4] | ESC 4 |
| Send Message | | | ESC s |
| Send Unprotected Message | | | ESC S |
| Send Page (Unprotected Only) | ESC 5 | | ESC 5 |

* Print Mode is automatically enabled during the execution of this command; then, disabled following its execution.

Note: Commands in "[]"s are QVT 119 commands honored in other emulations.

APPENDIX A. COMMAND SET SUMMARY (Cont)

| COMMAND | QVT 119 | ADDS A2 | WY-50 |
|---|------------------------|-----------------------|-------------------------|
| SEND FUNCTIONS (Cont) | | | |
| Send Line (All) | ESC 6 | ESC 6 | ESC 6 |
| Send Page (All) | ESC 7 | [ESC 7] | ESC 7 |
| Send from Top of Screen to Cursor | ESC 8 | [ESC 8] | |
| Send ID Message | CTRL-E | | CTRL-E |
| MISCELLANEOUS | | | |
| Self-Test Enable | ESC V | [ESC V] | |
| Self-Test Disable | SHIFT/CLEAR | | |
| Status Line: | | | |
| Display | ESC } | [ESC] | |
| Blank | ESC { | [ESC] | |
| "H" Pattern: | | | |
| Display | CTRL-SHIFT/ SETUP-0 | CTRL-SHIFT SETUP-0 | |
| Blank | SHIFT/CLEAR | SHIFT/CLEAR | |
| Next Page/Segment | ESC w + | [ESC w +] | ESC J/ Page Next |
| Previous Page/Segment | ESC w - | [ESC w -] | ESC K/ Page Previous |
| Select Page Mode | ESC w P | [ESC w P] | |
| Select Page Mode at Page n | ESC w n P | [ESC w n P] | |
| Select Split Mode | ESC w S | [ESC w S] | |
| Select Split Mode at Segment n | ESC w n S | [ESC w n S] | |
| Select Full Screen and Page Mode | ESC w s | [ESC w s] | |
| Select Full Screen and Split Mode | | | ESC x Ø |
| Select Segment Mode with Split Line Partition | ESC w n s | [ESC w n s] | ESC x 1 HRS |
| Skip to Specific Text Segment/Page | | | ESC - <nrc> |
| Activate Text Segment/Page 0 | | | ESC] |
| Activate Text Segment/Page 1 | | | ESC } |

Note: Commands in "[]"s are QVT 119 commands honored in other emulations.

APPENDIX A. COMMAND SET SUMMARY (Cont)

| COMMAND | QVT 119 | ADDS A2 | WY-50 |
|--|-----------------------------|-------------------------------|----------------------------|
| MISCELLANEOUS (Cont) | | | |
| Program Function Key | ESC Kn <ID> DLM DATA DLM | [ESC Knn<ID>] DLM DATA DLM | ESC z Value SEQ DEL |
| Program Function Key | ESC z n data | [ESC z n data CR] | ESC z n data CR |
| Program Function Key/ Arrow Keys | ESC Kn <ID> DLM DATA DLM | [ESC Kn <ID>] DLM DATA DLM | |
| Enter end of Message (EXT) | | | ESC 9 |
| Enter Start-of-(STX) | | | ESC 8 |
| Set Attributes for Message Field/Screen | ESC a<n ATTR> | [ESC a <n ATTR>] | ESC A<n ATTR> |
| Duplex Edit Submode ON | | | ESC 1(L) |
| Full Duplex Mode ON | | | ESC D F |
| Set Protect Column | | | ESC V |
| Half Duplex Block Mode ON | | | ESC D H then ESC B |
| Half Duplex Mode ON | | | ESC D H |
| Insert Submode OFF | ESC r | [ESC r] | ESC r REPL |
| Insert Submode ON | ESC q | [ESC q] | ESC q INS |
| Local Edit Submode ON | | | ESC k |
| No Scroll Submode OFF | | | ESC 0 |
| No Scroll;1 Submode ON | | | ESC N |
| Display Setup Parameters | | | SHIFT/SETUP |
| Identify Terminal Keyclick ON/OFF | | | ESC (SPACE) SHIFT/ENTER |
| Enable Transmission | | | CTRL-Q |
| Disable Transmission | | | CTRL-s |
| Initiate Escape Code Sequence | | | CTRL-[|
| Interrupt a Transmission | | | ESC BREAK |
| Return ACK | | | CTRL-E |
| Hard Reset | ESC ! 0 | | |
| Soft Reset | ESC ! 1 | | |
| Save | ESC ! 2 | | |

Note: Commands in "[]"s are QVT 119 commands honored in other emulations.

APPENDIX B. PROGRAMMING the FUNCTION KEYS and CURSOR ARROW KEYS

Function Keys: F1 - F20 (Default Selection)

Each of the Function keys transmits to the host computer an ASCII character bracketed by a CTRL-A (SOH) code and a Carriage Return (CR) code. A Function key may be used by itself, or with the Shift key, to generate a total of 40 codes. A maximum of 255 bytes can be dynamically allocated to a single function key out of the 380 bytes available in non-volatile RAM. Default Function key and Cursor Arrow key codes are listed below.

Default Function Key Codes

| KEY | IDENTIFIER | QVT 119 | ADDS A2 | WYSE 50 |
|-----------|------------|--------------------|--------------------|--------------------|
| | | DEFAULT CODE VALUE | DEFAULT CODE VALUE | DEFAULT CODE VALUE |
| F1 | @ | CTRL-A @ CR | CTRL-B 1 CR | CTRL-A @ CR |
| F2 | A | CTRL-A A CR | CTRL-B 2 CR | CTRL-A A CR |
| F3 | B | CTRL-A B CR | CTRL-B 3 CR | CTRL-A B CR |
| F4 | C | CTRL-A C CR | CTRL-A C CR | CTRL-A C CR |
| F5 | D | CTRL-A D CR | CTRL-A D CR | CTRL-A D CR |
| F6 | E | CTRL-A E CR | CTRL-A E CR | CTRL-A E CR |
| F7 | F | CTRL-A F CR | CTRL-A F CR | CTRL-A F CR |
| F8 | G | CTRL-A G CR | CTRL-A G CR | CTRL-A G CR |
| F9 | H | CTRL-A H CR | CTRL-A H CR | CTRL-A H CR |
| F10 | I | CTRL-A I CR | CTRL-A I CR | CTRL-A I CR |
| F11 | J | CTRL-A J CR | CTRL-A J CR | CTRL-A J CR |
| F12 | K | CTRL-A K CR | CTRL-A K CR | CTRL-A K CR |
| F13 | L | CTRL-A L CR | CTRL-A L CR | CTRL-A L CR |
| F14 | M | CTRL-A M CR | CTRL-A M CR | CTRL-A M CR |
| F15 | N | CTRL-A N CR | CTRL-A N CR | CTRL-A N CR |
| F16 | O | CTRL-A O CR | CTRL-A O CR | CTRL-A O CR |
| F17 | P | ESC Q | ESC Q | ESC Q |
| F18 | Q | ESC W | ESC W | ESC W |
| F19 | R | ESC T | ESC T | ESC T |
| F20 | S | ESC r | ESC r | ESC r |
| Shift-F1 | | CTRL-A CR | CTRL-B ! CR | CTRL-A ' CR |
| Shift-F2 | a | CTRL-A a CR | CTRL-B " CR | CTRL-A a CR |
| Shift-F3 | b | CTRL-A b CR | CTRL-B # CR | CTRL-A b CR |
| Shift-F4 | c | CTRL-A c CR | CTRL-A c CR | CTRL-A c CR |
| Shift-F5 | d | CTRL-A d CR | CTRL-A d CR | CTRL-A d CR |
| Shift-F6 | e | CTRL-A e CR | CTRL-A e CR | CTRL-A e CR |
| Shift-F7 | f | CTRL-A f CR | CTRL-A f CR | CTRL-A f CR |
| Shift-F8 | g | CTRL-A g CR | CTRL-A g CR | CTRL-A g CR |
| Shift-F9 | h | CTRL-A h CR | CTRL-A h CR | CTRL-A g CR |
| Shift-F10 | i | CTRL-A i CR | CTRL-A i CR | CTRL-A i CR |

APPENDIX B. PROGRAMMING the FUNCTION KEYS and CURSOR ARROW KEYS (Cont)

Default Function Key Codes (Cont)

| KEY | IDENTI- FIER | QVT 119 | ADDS A2 | WYSE 50 |
|-----------|-----------------|-----------------------|-----------------------|-----------------------|
| | | DEFAULT CODE VALUE | DEFAULT CODE VALUE | DEFAULT CODE VALUE |
| Shift-F11 | j | CTRL-A j CR | CTRL-A j CR | CTRL-A j CR |
| Shift-F12 | k | CTRL-A k CR | CTRL-A k CR | CTRL-A k CR |
| Shift-F13 | l | CTRL-A l CR | CTRL-A l CR | CTRL-A l CR |
| Shift-F14 | m | CTRL-A m CR | CTRL-A m CR | CTRL-A m CR |
| Shift-F15 | n | CTRL-A n CR | CTRL-A n CR | CTRL-A n CR |
| Shift-F16 | o | CTRL-A o CR | CTRL-A o CR | CTRL-A o CR |
| Shift-F17 | p | ESC E | ESC E | ESC E |
| Shift-F18 | q | ESC R | ESC R | ESC R |
| Shift-F19 | r | ESC Y | ESC Y | ESC Y |
| Shift-F20 | s | ESC q | ESC q | ESC q |

Default Cursor Arrow Key Codes

| KEY | IDENTI- FIER | QVT 119 | ADDS A2 | WYSE 50 |
|-------------|-----------------|-----------------------|-----------------------|-----------------------|
| | | DEFAULT CODE VALUE | DEFAULT CODE VALUE | DEFAULT CODE VALUE |
| Up Arrow | Space | CTRL-K | CTRL-Z | CTRL-K |
| Down Arrow | ! | CTRL-J | CTRL-J | CTRL-J |
| Left Arrow | " | CTRL-H | CTRL-F | CTRL-H |
| Right Arrow | # | CTRL-L | CTRL-U | CTRL-L |

APPENDIX B. PROGRAMMING the FUNCTION KEYS and CURSOR ARROW KEYS (Cont)

Function Keys (Programmable Selection): F1 - F16, F17 (Insert), F18 (Delete), F19 (Clear), F20 (Insert/Replace)

The Function Keys listed above may be user-programmed from either the keyboard or by command sequence. To program a Function Key from the keyboard, or to display its contents, proceed as follows:

1. Enter Setup Mode (Shift/Setup).
2. Depress the Funct key. Note that the Setup Line changes to display the contents of Function Key F1.
3. Depress the Function key (Normal or Shifted) whose contents you wish to view and/or program.
4. Specify the application (routing) of the contents of the Function key according to the following scheme: Enter \emptyset , or 1 through 7, where,
 - \emptyset directs the contents of the key for current (default) application.
 - 1 directs the contents of the key to the EIA Port.
 - 2 directs the contents of the key for local application only.
 - 3 combines 1 and 2 (application locally; routing to the EIA Port).
 - 4 directs the contents of the key to the AUX Port.
 - 5 combines 1 and 4 (routing to the EIA and AUX Ports).
 - 6 combines 2 and 4 (application locally; routing to the AUX Port).
 - 7 combines 1, 2, and 4 (application locally; routing to the EIA and AUX Ports).
5. Enter the desired data string. Use the cursor arrow keys to move the cursor within the contents of the key to perform any editing, or the Home key to return the cursor to the beginning of the key contents. When editing, new data replaces old data at the cursor position.
6. Depress the Enter key to temporarily store the contents of the key.
7. Repeat the above steps to program the contents of any of the remaining Function keys.
7. To "save" the programmed contents of the Function key(s), depress the Shift-S keys while still in Setup Mode.

Programming a Function key by Command Sequence.

| EMULATION | COMMAND |
|-------------------|---|
| QVT 119 & ADDS A2 | ESC Kn function key identifier DELIMITER DATA DELIMITER |

(where "n" specifies the routing scheme; refer to Step 4 above)

APPENDIX B. PROGRAMMING the FUNCTION KEYS and CURSOR ARROW KEYS (Cont)**Cursor Arrow Keys**

The cursor arrow keys may be user-programmed from the keyboard, or by command sequence.

To program a cursor arrow key from the keyboard proceed as follows:

1. Enter Setup Mode (Shift/Setup).
2. Depress Funct key.
3. Depress the Shift key along with the cursor arrow key whose contents you wish to view and/or program.
4. Specify the application (routing) of the contents of the Function key according to the following scheme: Enter \emptyset , or 1 through 7, where,
 - \emptyset directs the contents of the key for current (default) application.
 - 1 directs the contents of the key to the EIA Port.
 - 2 directs the contents of the key for local application only.
 - 3 combines 1 and 2 (application locally; routing to the EIA Port).
 - 4 directs the contents of the key to the AUX Port.
 - 5 combines 1 and 4 (routing to the EIA and AUX Ports).
 - 6 combines 2 and 4 (application locally; routing to the AUX Port).
 - 7 combines 1, 2, and 4 (application locally; routing to the EIA and AUX Ports).
5. Enter the desired data string. Use the cursor arrow keys to move the cursor within the contents of the key to perform any editing, or the Home key to return the cursor to the beginning of the key contents. When editing, new data replaces old data at the cursor position.
6. Depress the Enter key to temporarily store the contents of the key.
7. Repeat the above steps to program the contents of any of the remaining Cursor Arrow keys.
8. To "save" the programmed contents of the Cursor Arrow key(s), depress the Shift-S keys while still in Setup Mode.

Programming a Cursor Arrow key by command sequence.

| EMULATION | COMMAND |
|---|--|
| QVT 119 & ADDS A2 | ESC Kn arrow key identifier DELIMITER DATA DELIMITER |
| (where "n" specifies the routing scheme; refer to Step 4 above) | |

APPENDIX C. CURSOR ADDRESSING

Cursor addressing allows the capability of assigning the cursor to a specific location on the display screen; cursor reading is an enquiry function, used to request the coordinates of the cursor. Refer to the appropriate Cursor Addressing Coordinates list for the emulation in use.

QVT 119 Cursor Addressing Command Sequence

| EMULATION | COMMAND |
|----------------------|--|
| QVT 119 (80 Column) | ESC = Line # Column # |
| QVT 119 (132 Column) | ESC = Line # n Column # (where n = 70H or greater) |

QVT 119 Cursor Addressing Coordinates (Columns 1 through 80)

| LINE | | COLUMN | | | | | |
|------|-----------|--------|-----------|--------|-----------|--------|-----------|
| LINE | CHARACTER | COLUMN | CHARACTER | COLUMN | CHARACTER | COLUMN | CHARACTER |
| 1 | Space | 1 | Space | 28 | ; | 55 | V |
| 2 | ! | 2 | ! | 29 | < | 56 | W |
| 3 | " | 3 | " | 30 | = | 57 | X |
| 4 | # | 4 | # | 31 | > | 58 | Y |
| 5 | \$ | 5 | \$ | 32 | ? | 59 | Z |
| 6 | % | 6 | % | 33 | @ | 60 | [|
| 7 | & | 7 | & | 34 | A | 61 | \ |
| 8 | ' | 8 | ' | 35 | B | 62 |] |
| 9 | (| 9 | (| 36 | C | 63 | ^ |
| 10 |) | 10 |) | 37 | D | 64 | ~ |
| 11 | * | 11 | * | 38 | E | 65 | ` |
| 12 | + | 12 | + | 39 | F | 66 | a |
| 13 | , | 13 | , | 40 | G | 67 | b |
| 14 | - | 14 | - | 41 | H | 68 | c |
| 15 | . | 15 | . | 42 | I | 69 | d |
| 16 | / | 16 | / | 43 | J | 70 | e |
| 17 | 0 | 17 | 0 | 44 | K | 71 | f |
| 18 | 1 | 18 | 1 | 45 | L | 72 | g |
| 19 | 2 | 19 | 2 | 46 | M | 73 | h |
| 20 | 3 | 20 | 3 | 47 | N | 74 | i |
| 21 | 4 | 21 | 4 | 48 | O | 75 | j |
| 22 | 5 | 22 | 5 | 49 | P | 76 | k |
| 23 | 6 | 23 | 6 | 50 | Q | 77 | l |
| 24 | 7 | 24 | 7 | 51 | R | 78 | m |
| | | 25 | 8 | 52 | S | 79 | n |
| | | 26 | 9 | 53 | T | 80 | o |
| | | 27 | : | 54 | U | | |

APPENDIX

APPENDIX C. CURSOR ADDRESSING (Cont)

QVT 119 Cursor Addressing Coordinates (Columns 81 through 132)

Note: Use These Coordinates After Sending 70H or Greater to indicate extended column address.

| LINE | | COLUMN | | | |
|------|-----------|--------|-----------|--------|-----------|
| LINE | CHARACTER | COLUMN | CHARACTER | COLUMN | CHARACTER |
| 1 | Space | 81 | Space | 108 | ; |
| 2 | ! | 82 | ! | 109 | < |
| 3 | " | 83 | " | 110 | = |
| 4 | # | 84 | # | 111 | > |
| 5 | \$ | 85 | \$ | 112 | ? |
| 6 | % | 86 | % | 113 | @ |
| 7 | & | 87 | & | 114 | A |
| 8 | ' | 88 | ' | 115 | B |
| 9 | (| 89 | (| 116 | C |
| 10 |) | 90 |) | 117 | D |
| 11 | * | 91 | * | 118 | E |
| 12 | + | 92 | + | 119 | F |
| 13 | , | 93 | , | 120 | G |
| 14 | - | 94 | - | 121 | H |
| 15 | . | 95 | . | 122 | I |
| 16 | / | 96 | / | 123 | J |
| 17 | 0 | 97 | 0 | 124 | K |
| 18 | 1 | 98 | 1 | 125 | L |
| 19 | 2 | 99 | 2 | 126 | M |
| 20 | 3 | 100 | 3 | 127 | N |
| 21 | 4 | 101 | 4 | 128 | O |
| 22 | 5 | 102 | 5 | 129 | P |
| 23 | 6 | 103 | 6 | 130 | Q |
| 24 | 7 | 104 | 7 | 131 | R |
| | | 105 | 8 | 132 | S |
| | | 106 | 9 | | |
| | | 107 | : | | |

APPENDIX C. CURSOR ADDRESSING (Cont)

ADDS A2 Cursor Addressing Command Sequence

| EMULATION | COMMAND |
|-----------|-----------------------|
| ADDS A2 | ESC Y Line # Column # |

ADDS A2 Cursor Addressing Coordinates

| LINE | | COLUMN | | | | | |
|------|-----------|--------|-----------|--------|-----------|--------|-----------|
| LINE | CHARACTER | COLUMN | CHARACTER | COLUMN | CHARACTER | COLUMN | CHARACTER |
| 1 | @ | 1 | CTRL-@ | 28 | ' | 55 | T |
| 2 | A | 2 | CTRL-A | 29 | (| 56 | Y |
| 3 | B | 3 | CTRL-B | 30 |) | 57 | V |
| 4 | C | 4 | CTRL-C | 31 | 0 | 58 | W |
| 5 | D | 5 | CTRL-D | 32 | 1 | 59 | X |
| 6 | E | 6 | CTRL-E | 33 | 2 | 60 | Y |
| 7 | F | 7 | CTRL-F | 34 | 3 | 61 | \ |
| 8 | G | 8 | CTRL-G | 35 | 4 | 62 | a |
| 9 | H | 9 | CTRL-H | 36 | 5 | 63 | b |
| 10 | I | 10 | CTRL-I | 37 | 6 | 64 | c |
| 11 | J | 11 | CTRL-P | 38 | 7 | 65 | d |
| 12 | K | 12 | CTRL-Q | 39 | 8 | 66 | e |
| 13 | L | 13 | CTRL-R | 40 | 9 | 67 | f |
| 14 | M | 14 | CTRL-S | 41 | @ | 68 | g |
| 15 | N | 15 | CTRL-T | 42 | A | 69 | h |
| 16 | O | 16 | CTRL-U | 43 | B | 70 | i |
| 17 | P | 17 | CTRL-V | 44 | C | 71 | p |
| 18 | Q | 18 | CTRL-W | 45 | D | 72 | q |
| 19 | R | 19 | CTRL-X | 46 | E | 73 | r |
| 20 | S | 20 | CTRL-Y | 47 | F | 74 | s |
| 21 | T | 21 | SPACE | 48 | G | 75 | t |
| 22 | U | 22 | ! | 49 | H | 76 | u |
| 23 | V | 23 | " | 50 | I | 77 | v |
| 24 | W | 24 | # | 51 | P | 78 | w |
| | | 25 | \$ | 52 | Q | 79 | x |
| | | 26 | % | 53 | R | 80 | y |
| | | 27 | & | 54 | S | | |

APPENDIX

APPENDIX C. CURSOR ADDRESSING (Cont)

WY-50 Cursor Addressing Command Sequence

| EMULATION | COMMAND |
|-----------|---------------------------|
| WY-50 | ESC a Line # R Column # C |

WY-50 Cursor Addressing Coordinates

| LINE | | COLUMN | | | | | |
|------|-----------|--------|-----------|--------|-----------|--------|-----------|
| LINE | CHARACTER | COLUMN | CHARACTER | COLUMN | CHARACTER | COLUMN | CHARACTER |
| 1 | Space | 1 | Space | 28 | ; | 55 | V |
| 2 | ! | 2 | ! | 29 | < | 56 | W |
| 3 | " | 3 | " | 30 | = | 57 | X |
| 4 | # | 4 | # | 31 | > | 58 | Y |
| 5 | % | 5 | % | 32 | ? | 59 | Z |
| 6 | \$ | 6 | \$ | 33 | @ | 60 | [|
| 7 | & | 7 | & | 34 | A | 61 | \ |
| 8 | ' | 8 | ' | 35 | B | 62 |] |
| 9 | (| 9 | (| 36 | C | 63 | ^ |
| 10 |) | 10 |) | 37 | D | 64 | ~ |
| 11 | * | 11 | * | 38 | E | 65 | ` |
| 12 | + | 12 | + | 39 | F | 66 | a |
| 13 | , | 13 | , | 40 | G | 67 | b |
| 14 | - | 14 | - | 41 | H | 68 | c |
| 15 | . | 15 | . | 42 | I | 69 | d |
| 16 | / | 16 | / | 43 | J | 70 | e |
| 17 | 0 | 17 | 0 | 44 | K | 71 | f |
| 18 | 1 | 18 | 1 | 45 | L | 72 | g |
| 19 | 2 | 19 | 2 | 46 | M | 73 | h |
| 20 | 3 | 20 | 3 | 47 | N | 74 | i |
| 21 | 4 | 21 | 4 | 48 | O | 75 | j |
| 22 | 5 | 22 | 5 | 49 | P | 76 | k |
| 23 | 6 | 23 | 6 | 50 | Q | 77 | l |
| 24 | 7 | 24 | 7 | 51 | R | 78 | m |
| | | 25 | 8 | 52 | S | 79 | n |
| | | 26 | 9 | 53 | T | 80 | o |
| | | 27 | : | 54 | U | | |

APPENDIX D. GRAPHICS MODE CHARACTER SETS

Graphics Mode is a special applications feature of the terminal, that reassigns the alphanumeric codes of selected keystrokes, with thin-line and block style graphics symbols (refer to Graphics Mode Character Set listings below). Graphics Mode may be selected from the Set 1 Setup Menu or by command sequence.

Graphics Mode Command Sequences





































| EMULATION | COMMAND |
|--|--|
| To Enter Graphics Mode QVT 119 & ADDS A2 WY-50 | ESC \$ ESC H CTRL-B To display a single character: ESC H x |
| To Exit Graphics Mode QVT 119 & ADDS A2 WY-50 | ESC % ESC H CTRL-C |

Thin-Line Graphic Characters Set (QVT 119 and ADDS A2)

| KEY | GRAPHIC CHARACTER | KEY | GRAPHIC CHARACTER |
|-----|-------------------|-----|-------------------|
| a | | k | |
| b | | l | |
| c | | m | |
| d | | n | |
| e | | o | |
| f | | p | |
| g | | q | |
| h | | r | |
| i | | s | |
| j | | | |





























APPENDIX D. GRAPHICS MODE CHARACTER SETS (Cont)

Block Style Graphic Characters Set (QVT 119 and ADDS A2)

| KEY DEPRESSED | HEX | DISPLAY | KEY DEPRESSED | HEX | DISPLAY |
|---------------|-----|---|---------------|-----|---|
| Space | C0 |  | 2 | D2 |  |
| ! | C1 |  | 3 | D3 |  |
| " | C2 |  | 4 | D4 |  |
| # | C3 |  | 5 | D5 |  |
| \$ | C4 |  | 6 | D6 |  |
| % | C5 |  | 7 | D7 |  |
| & | C6 |  | 8 | D8 |  |
| ' | C7 |  | 9 | D9 |  |
| (| C8 |  | : | DA |  |
|) | C9 |  | ; | DB |  |
| * | CA |  | < | DC |  |
| + | CB |  | = | DD |  |
| , | CC |  | > | DE |  |
| - | CD |  | ? | DF |  |
| . | CE |  | @ | E0 |  |
| / | CF |  | A | E1 |  |
| 0 | DO |  | B | E2 |  |
| 1 | D1 |  | C | E3 |  |

APPENDIX D. GRAPHICS MODE CHARACTER SETS (Cont)

Block Style Graphic Characters Set (QVT 119 and ADDS A2)

| KEY DEPRESSED | HEX | DISPLAY | KEY DEPRESSED | HEX | DISPLAY |
|---------------|-----|---|---------------|-----|---|
| D | E4 |  | V | F6 |  |
| E | E5 |  | W | F7 |  |
| F | E6 |  | X | F8 |  |
| G | E7 |  | Y | F9 |  |
| H | E8 |  | Z | FA |  |
| I | E9 |  | [| FB |  |
| J | EA |  | \ | FC |  |
| K | EB |  |] | FD |  |
| L | EC |  | ^ | FE |  |
| M | ED |  | - | FF |  |
| N | EE |  | | | |
| O | EF |  | | | |
| P | FO |  | | | |
| Q | F1 |  | | | |
| R | F2 |  | | | |
| S | F3 |  | | | |
| T | F4 |  | | | |
| U | F5 |  | | | |

APPENDIX D. GRAPHICS MODE CHARACTER SETS (Cont)

Graphic Characters Set (WY-50)

| KEY | GRAPHIC CHARACTER |
|-----|-------------------|
| Ø | T |
| 1 | L |
| 2 | ┌ |
| 3 | ┐ |
| 4 | └ |
| 5 | ┘ |
| 6 | |
| 7 | ■ |
| 8 | + |
| 9 | ┆ |
| : | — |
| ; | ▒ |
| < | = |
| = | ┆ |
| > | |
| ? | ▒ |

APPENDIX E. ASCII CODE CHART

| Bits | | | | | Column | 0 | 1 | 2 | 3 | 4 | 5 | 6 | 7 | |
|------|----|----|----|----|--------|-----|-----|-----|----|---|---|---|-----|---|
| b7 | b6 | b5 | b4 | b3 | b2 | b1 | 0 | 1 | 2 | 3 | 4 | 5 | 6 | 7 |
| | | | | | Row | 0 | 1 | 2 | 3 | 4 | 5 | 6 | 7 | |
| 0 | 0 | 0 | 0 | 0 | 0 | 0 | NUL | DLE | SP | 0 | @ | P | ' | p |
| 0 | 0 | 0 | 1 | 1 | 1 | SOH | DC1 | ! | 1 | A | Q | a | q | |
| 0 | 0 | 1 | 0 | 1 | 0 | STX | DC2 | " | 2 | B | R | b | r | |
| 0 | 0 | 1 | 1 | 1 | 0 | ETX | DC3 | # | 3 | C | S | c | s | |
| 0 | 1 | 0 | 0 | 1 | 0 | EOT | DC4 | \$ | 4 | D | T | d | t | |
| 0 | 1 | 0 | 1 | 1 | 0 | ENQ | NAK | % | 5 | E | U | e | u | |
| 0 | 1 | 1 | 0 | 1 | 0 | ACK | SYN | & | 6 | F | V | f | v | |
| 0 | 1 | 1 | 1 | 1 | 0 | BEL | ETB | ' | 7 | G | W | g | w | |
| 1 | 0 | 0 | 0 | 1 | 0 | BS | CAN | (| 8 | H | X | h | x | |
| 1 | 0 | 0 | 1 | 1 | 0 | HT | EM |) | 9 | I | Y | i | y | |
| 1 | 0 | 1 | 0 | 1 | 0 | LF | SUB | * | : | J | Z | j | z | |
| 1 | 0 | 1 | 1 | 1 | 0 | VT | ESC | + | ; | K | [| k | { | |
| 1 | 1 | 0 | 0 | 1 | 0 | FF | FS | , | < | L | \ | l | | |
| 1 | 1 | 0 | 1 | 1 | 0 | CR | GS | - | = | M |] | m | } | |
| 1 | 1 | 1 | 0 | 1 | 0 | SO | RS | . | > | N | ^ | n | ~ | |
| 1 | 1 | 1 | 1 | 1 | 0 | SI | US | / | ? | O | _ | o | DEL | |

APPENDIX F. EIA and AUX CONNECTOR PIN ASSIGNMENTS

EIA Connector (Host Computer)

| PIN NUMBER | DESCRIPTION |
|------------|--|
| 1 | Chassis Ground |
| 2 | Transmit Data |
| 3 | Receive Data |
| 4 | Request to Send |
| 5 | Clear to Send |
| 6 | Data Set Ready |
| 7 | Signal Ground |
| 8 | Data Carrier Detect |
| 11 | Secondary Break (optional) |
| 15 | Current Loop, Receive +, or RS 422, Receive - |
| 17 | Current Loop, Transmit -. or RS 422, Transmit + |
| 20 | Data Terminal Ready |
| 24 | Current Loop, Receive -, or RS 422 Receive + |
| 25 | Current Loop, Transmit +, or RS 422, Transmit - |

AUX Connector (Printer)

| PIN NUMBER | DESCRIPTION |
|------------|-------------------------------|
| 1 | Chassis Ground |
| 2 | Receive Data |
| 3 | Transmit Data |
| 5 | Clear to Send (always active) |
| 6 | Data Set Ready |
| 7 | Signal Ground |
| 8 | Alternate Data Terminal Ready |
| 11 | Secondary Break (optional) |
| 20 | Data Terminal Ready |

REQUEST FOR READER'S COMMENTS

Qume Corporation wishes to provide documents that meet the needs of all QVT product users. Returning this form with your comments will help us to assure that we always produce quality manuals. Thank you.

1. Please specify by page, any errors you found in this manual.

2. Does the document offer the information you expect and require?

3. Is the document clearly written and to the proper level? Please note any areas where the wording is difficult to understand.

4. Is the information complete and organized so that topics can be easily located?

5. Please rate this document in the following categories:

| | Usability | Accuracy | Readability | Organization | Overall |
|-----------|-----------|----------|-------------|--------------|---------|
| Excellent | _____ | _____ | _____ | _____ | _____ |
| Very Good | _____ | _____ | _____ | _____ | _____ |
| Good | _____ | _____ | _____ | _____ | _____ |
| Fair | _____ | _____ | _____ | _____ | _____ |
| Poor | _____ | _____ | _____ | _____ | _____ |

6. May we have your suggestions for improvement.

7. Where did you purchase your QVT terminal?

Name _____ Title _____
Business _____
Address _____
City _____ State or Country _____ Zip Code _____

Fold Here

Fold Here

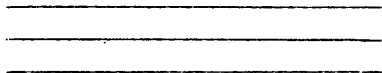

Postage

Qume Corporation
2350 Qume Drive
San Jose, California, U.S.A. 95131

Attn: Terminals Division,
Technical Publications