

**SA450**

**Double-sided Minifloppy™  
Diskette Storage Drive**

OEM Manual

 **Shugart**

# TABLE OF CONTENTS

1.0 Introduction	1
1.1 General Description	1
1.2 Specification Summary	2
1.2.1 Performance Specifications	2
1.2.2 Functional Specifications	2
1.2.3 Physical Specifications	3
1.2.4 Reliability Specifications	3
2.0 Functional Characteristics	4
2.1 General Operation	4
2.2 Read/Write and Control Electronics	4
2.3 Drive Mechanism	4
2.4 Positioning Mechanics	4
2.5 Read/Write Heads	4
2.6 Recording Formats	4
3.0 Functional Operations	7
3.1 Power Sequencing	7
3.2 Drive Selection	7
3.3 Motor On	7
3.4 Track Accessing	7
3.4.1 Step Out	7
3.4.2 Step In	8
3.5 Side Selection	8
3.6 Read Operation	9
3.7 Write Operation	10
3.8 Sequence of Events	12
4.0 Electrical Interface	13
4.1 Signal Interface	14
4.1.1 Input Lines	14
4.1.1.1 Input Line Terminations	15
4.1.1.2 Drive Select 1-4	15
4.1.1.3 Motor On	15
4.1.1.4 Direction Select	16
4.1.1.5 Step	16
4.1.1.6 Write Gate	16
4.1.1.7 Write Data	16
4.1.1.8 Side Select	17
4.1.1.9 In Use (Option)	17
4.1.2 Output Lines	17
4.1.2.1 Track 00	17
4.1.2.2 Index/Sector	17
4.1.2.3 Read Data	18
4.1.2.4 Write Protect	18
4.2 Power Interface	18
4.2.1 Frame Ground	19
5.0 Physical Interface	21
5.1 J1/P1 Connector	21
5.2 J2/P2 Connector	22
5.3 Frame Grounding	22

6.0 Drive Physical Specifications	23
6.1 Mechanical Dimensions	23
6.2 Mounting	23
7.0 Recording Format	24
7.1 General	24
7.2 Byte	24
7.3 Formats	25
7.3.1 Soft Sectored Recording Format	25
7.3.1.1 Track Layout	26
8.0 Operation Procedures	28
8.1 Minidiskette Loading	28
8.2 Minidiskette Handling	28

## LIST OF ILLUSTRATIONS

Figure 1.	SA450 Double Sided Minifloppy	III
2.	SA450 Functional Diagram	6
3.	Track Access Timing	8
4.	Read Initiate Timing	9
5.	Read Data Timing (FM)	10
6.	FM and MFM Code Comparisons	10
7.	Write Initiate Timing	11
8.	Write Data Timing (FM)	11
9.	General Control and Data Timing Requirements	12
10.	Interface Connections	13
11.	Interface Signal Driver/Receiver	14
12.	Step Timing	16
13.	Write Data Timing	17
14.	Index Timing (SA154 Media)	17
15.	Index/Sector Timing (SA155 Media)	18
16.	Index/Sector Timing (SA157 Media)	18
17.	Read Data Timing (FM)	19
18.	Interface Connectors-Physical Locations	21
19.	J1 Connector Dimensions	22
20.	J2 Connector	22
21.	SA450 Physical Dimensions	23
22.	Byte (FM Encoding)	24
23.	Data Bytes	24
24.	Recommended Soft Sector Singla Density (FM) (Even Boundaries)	25
25.	MFM Recommended Format - 256 Bytes/16 Records Per Track (IBM type)	25
26.	Recommended Hard Sector FM and MFM Formats	27

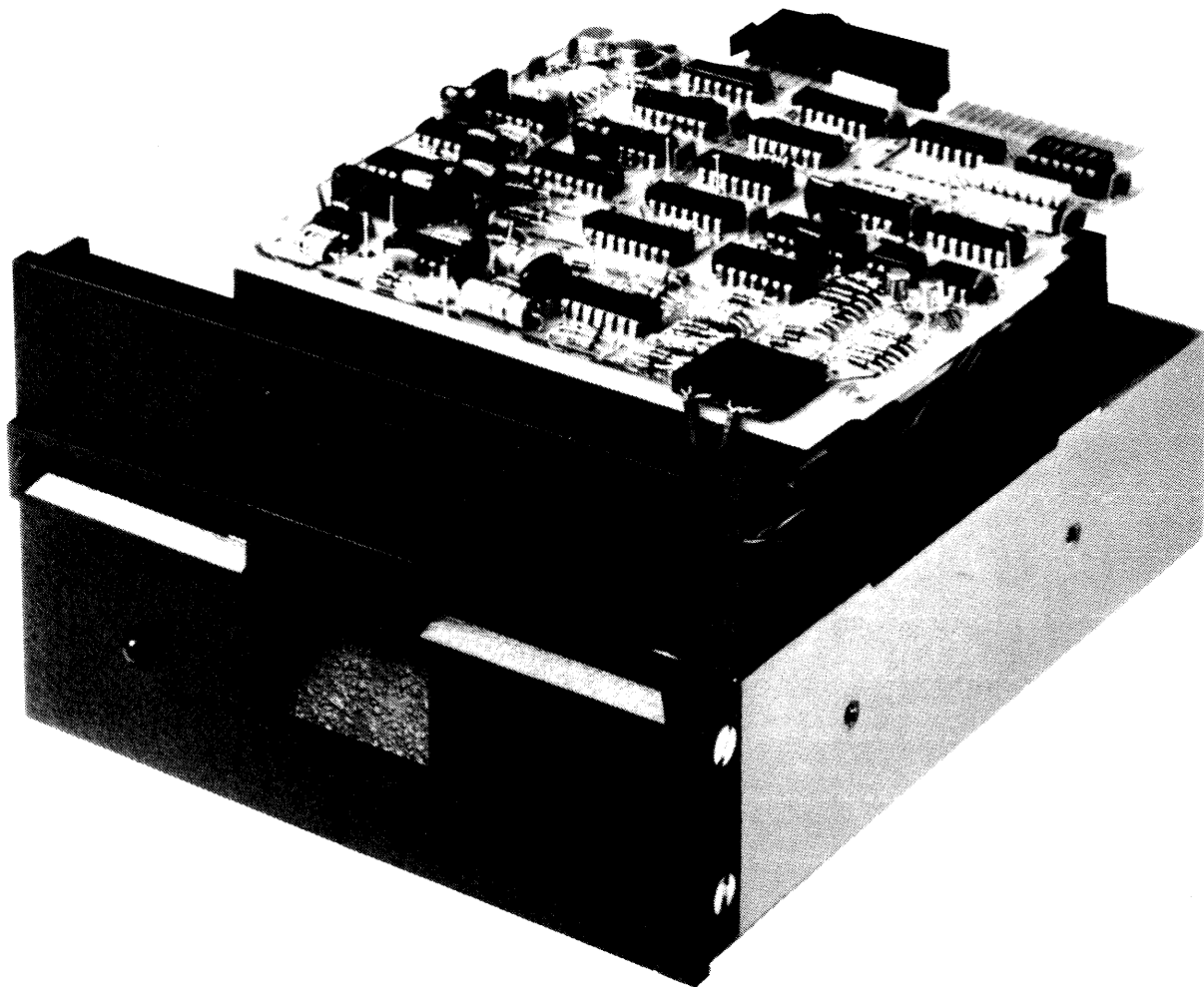

**FIGURE 1.** SA450 DOUBLE SIDED MINIFLOPPY

## 1.0 INTRODUCTION

### 1.1 General Description

The SA450 minifloppy Disk Drives are enhanced double-headed versions of the Shugart SA400 minifloppy drives. The SA450 provides up to four times the on-line storage capacity, and faster access time, along with improved reliability and maintainability.

SA450 drives read and write in single and double density on standard 5.25 inch diskettes and on both sides of two-sided diskettes. The new drives are exactly the same size as the Shugart SA400 and are plug compatible.

The compact SA450 minifloppy Disk Drive offers a reliable, low cost, high performance alternative to OEM data storage applications where tape cassette units would have been previously considered.

SA450 minifloppy drives have these standard features: compact size - 3.25" high × 5.75" wide × 8.0" deep, and weight of three pounds; lowest heat dissipation of any floppy drive; positive media insertion to keep the door from closing on media; DC drive motor with precision servo speed control and integral tachometer; unique stepping motor actuator with direct drive spiral cam and ball bearing V-groove positive detent; same proprietary glass bonded ferrite/ceramic read/write head as used in Shugart's large floppy drives; internal write protect circuitry; activity light, and solid die cast chassis.

Typical applications for the Shugart SA450 are word processing systems, entry level micro-processor systems, 'intelligent' calculators, program storage, hobby computer systems and other applications where low cost entry level random access data storage is a requirement.

#### Key Features

- Same compact size and weight as the SA400 - similar to most tape cassette units
- 440 Kbyte (unformatted) storage capacity
- SA400 I/O compatibility
- 125/250 Kbits/second transfer rate
- Single or double density capability
- Low heat dissipation
- Positive media insertion to avoid media damage
- DC drive motor (eliminates AC requirements)
- Proprietary Read/Write head; designed and manufactured by Shugart
- Write protect circuitry
- Activity light

## 1.2 Specification Summary

### 1.2.1 Performance Specifications

Capacity (in bytes)	Single Density (FM)	Double Density (MFM)
Unformatted		
Per Disk (40 Track)	250,000	500,000
(35 Track)	218,750	437,500
Per Surface (40 Track)	125,000	250,000
(35 Track)	109,375	218,750
Per Track	3,125	6,250
Formatted (16 Records/Track)		
Per Disk (40 Track)	163,840	327,680
(35 Track)	143,360	286,720
Per Track	2,048	4,096
Per Sector	128	256
Formatted (10 Records/Track)		
Per Disk (40 Track)	204,806	409,612
(35 Track)	179,200	358,400
Per Track	2560	5120
Per Sector	256	512
Formatted (18 Records/Track)		
Per Disk (40 Track)	N/A	N/A
(35 Track)	161,280	322,560
Per Track	2304	4608
Per Sector	128	256
Transfer Rate	125 kilobits/sec	250 kilobits/sec
Latency (avg.)	100 ms	100 ms
Access Time		
Track to Track	20 ms	20 ms
Average		
(40 Track)	275	275
(35 Track)	241	241
Settling Time	15 ms	15 ms

### 1.2.2 FUNCTIONAL SPECIFICATIONS

Rotational Speed	300 rpm	300 rpm
Recording Density		
(40 Track)	2938 BPI (FM)	5876 BPI (MFM)
(35 Track)	2728 BPI (FM)	5456 BPI (MFM)
Flux Density		
(40 Track)	5876 FCI (FM)	5876 FCI (MFM)
(35 Track)	5456 FCI (FM)	5876 FCI (MFM)
Track Density	48 tpi	48 tpi
Media Requirements		
SA154 (soft sectored)		
SA155 (16 sectors hard sectored)		
SA157 (10 sectors hard sectored)		
Industry standard flexible diskette		
Oxide on 0.003 in. (0.08mm) Mylar		
5.25 in. (133.4mm) square jacket		

### 1.2.3 Physical Specifications

<b>Environmental Limits</b>	<b>Operating</b>	<b>Shipping</b>	<b>Storage</b>
Ambient Temperature	40° to 115°F	-40° to 144°F	-8° to 117°F
Relative Humidity	20 to 80%	1 to 95%	1 to 95%
Maximum Wet Bulb	78°F	No Condensation	No Condensation

DC Voltage Requirements  
+ 12V ± 5% @ 1.80A Max.  
+ 5V ± 5% @ .70A Max.

#### Mechanical Dimensions (exclusive of front panel)

Width = 5.75 in. (146.1mm)

Height = 3.25 in. (82.6mm)

Depth = 8.0 in. (203.2mm) Nominal

Weight = 3 lbs. (1.36KG) Nominal

Power Dissipation = 11.5 Watts (40BTU/Hr) Continuous (typical)  
7.3 Watts (25BTU/HR) Standby (typical)

### 1.2.4 Reliability Specifications

MTBF: 8000 POH under typical usage

PM: Not required

MTTR: 30 minutes

#### Error Rates:

Soft Read Errors: 1 per  $10^9$  bits read.

Hard Read Errors: 1 per  $10^{12}$  bits read.

Seek Errors: 1 per  $10^6$  seeks.

#### Media Life:

Passes per Track:  $3.0 \times 10^6$

Insertions: 30,000 +

## **2.0 FUNCTIONAL CHARACTERISTICS**

### **2.1 General Operation**

The SA450 minifloppy Disk Drive consists of read/write and control electronics, drive mechanism, read/write head, and precision track positioning mechanism. These components perform the following functions:

- Interpret and generate control signals.
- Move read/write heads to the desired track.
- Read and write data.

The interface signals and their relationship to the internal functions are shown in Figure 2.

### **2.2 Read/Write and Control Electronics**

The electronics are packaged on one PCB which contains:

- Index Detector Circuits
- Head Position Actuator Driver
- Read/Write Amplifier and Transition Detector
- Write Protect
- Drive Select Circuit
- Drive Motor Control

### **2.3 Drive Mechanism**

The DC drive motor under servo speed control (using an integral tachometer) rotates the spindle at 300 rpm through a belt-drive system. An expandable collet/spindle assembly provides precision media positioning to ensure data interchange. A mechanical interlock prevents door closure without proper media insertion, thus eliminating media damage.

### **2.4 Positioning Mechanics**

The read/write head assembly is accurately positioned through the use of a precision spiral cam. This cam has a V-groove with a ball bearing follower which is attached to the head carriage assembly. Precise track location is accomplished as the cam is rotated in discrete increments by a stepping motor.

### **2.5 Read/Write Heads**

The proprietary heads are a single element ceramic read/write head with straddle erase elements to provide erased areas between data tracks. Thus normal interchange tolerances between media and drives will not degrade the signal to noise ratio and insures diskette interchangeability.

The read/write heads are mounted on a carriage which is located on precision carriage ways. The diskette is held in a plane perpendicular to the read/write heads by a platen located on the base casting. This precise registration assures perfect compliance with the read/write heads. The read/write heads are in direct contact with the diskette. The head surface has been designed to obtain maximum signal transfer to and from the magnetic surface of the diskette with minimum head/diskette wear.

### **2.6 Recording Formats**

The format of the data recorded on the diskette is totally a function of the host system, and can be designed around the users application to take maximum advantage of the total available bits that can be written on any one track.

For a detailed discussion of the various recording formats refer to Section 7.0.





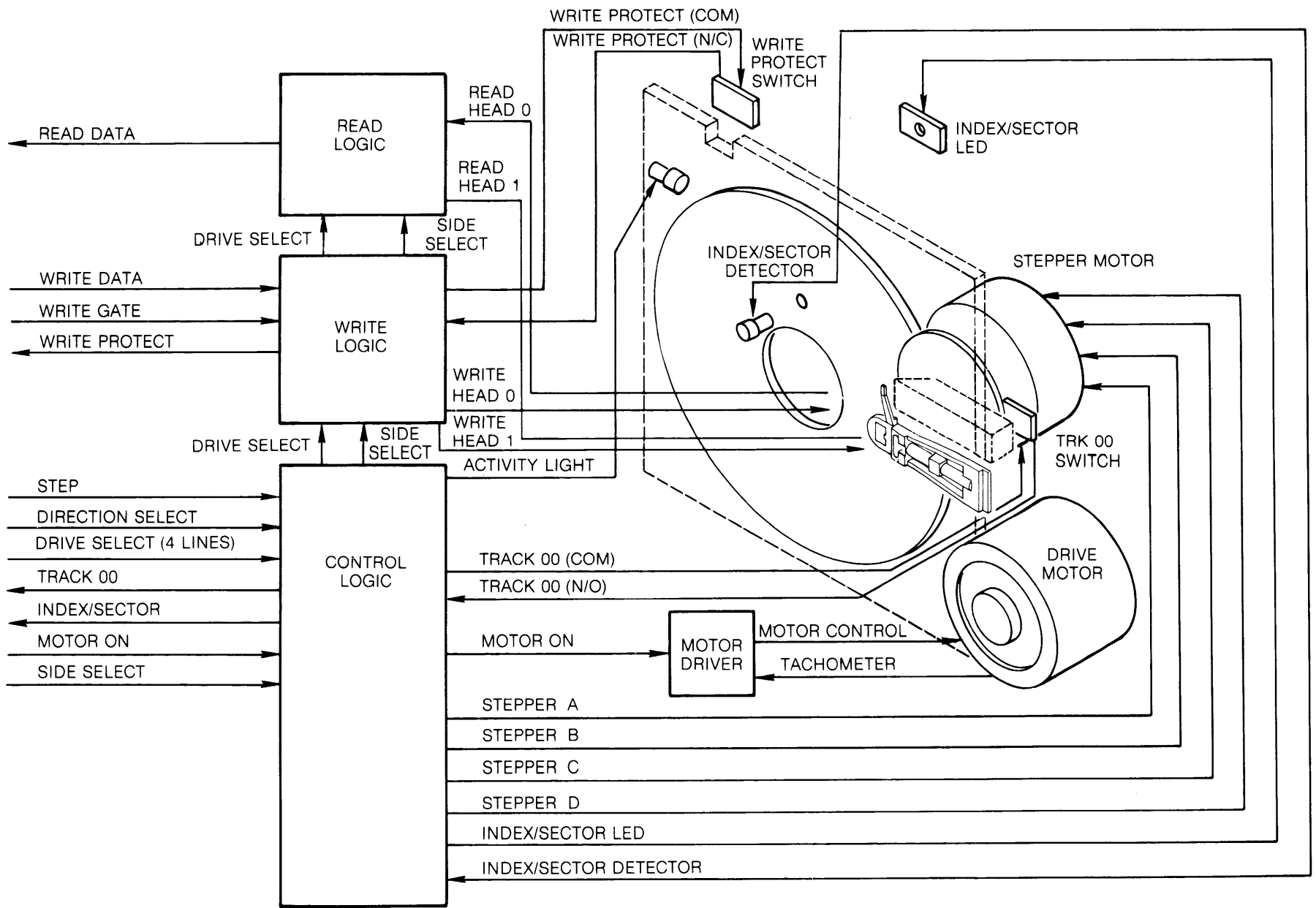

**FIGURE 2. SA450 FUNCTIONAL DIAGRAM**

## **3.0 FUNCTIONAL OPERATIONS**

### **3.1 Power Sequencing**

Applying DC power to the SA450 can be done in any sequence; however, during power up, the WRITE GATE line must be held inactive or at a high level. This will prevent possible "glitching" of the media. After application of DC power, a 100 ms delay should be introduced before any operation is performed. Also, after powering on, initial position of the read/write heads with respect to the data tracks on the media is indeterminate. In order to assure proper positioning of the read/write heads after power on, a Step Out operation should be performed until the Track 00 line becomes active (Recalibrate).

### **3.2 Drive Selection**

Drive selection occurs when a drive's DRIVE SELECT line is activated. Only the drive with this line active will respond to input lines or gate output lines.

### **3.3 Motor On**

In order for the host system to read or write data the DC drive motor must be turned on. This is accomplished by activating the line -MOTOR ON. A 0.5 second delay must be introduced after activating this line to allow the motor to come up to speed before reading or writing can be accomplished.

The motor must be turned off by the host system by deactivating the MOTOR ON line. This should be done if the drive has not received a new command within two (2) seconds (10 revolutions of diskette) after completing the execution of a command. This will insure maximum motor and media life.

### **3.4 Track Accessing**

Seeking the read/write heads from one track to another is accomplished by:

- a. Activating DRIVE SELECT line.
- b. Selecting desired direction utilizing DIRECTION SELECT line.
- c. WRITE GATE being inactive.
- d. Pulsing the STEP line.

Multiple track accessing is accomplished by repeated pulsing of the STEP line until the desired track has been reached. Each pulse on the STEP line will cause the read/write heads to move one track either in or out depending on the DIRECTION SELECT line. Head movement is initiated on the trailing edge of the STEP pulse.

#### **3.4.1 Step Out**

With the DIRECTION SELECT line at a plus logic level (2.4V to 5.25V) a pulse on the STEP line will cause the read/write heads to move one track away from the center of the disk. The pulse(s) applied to the STEP line must have the timing characteristics shown in Figure 3.

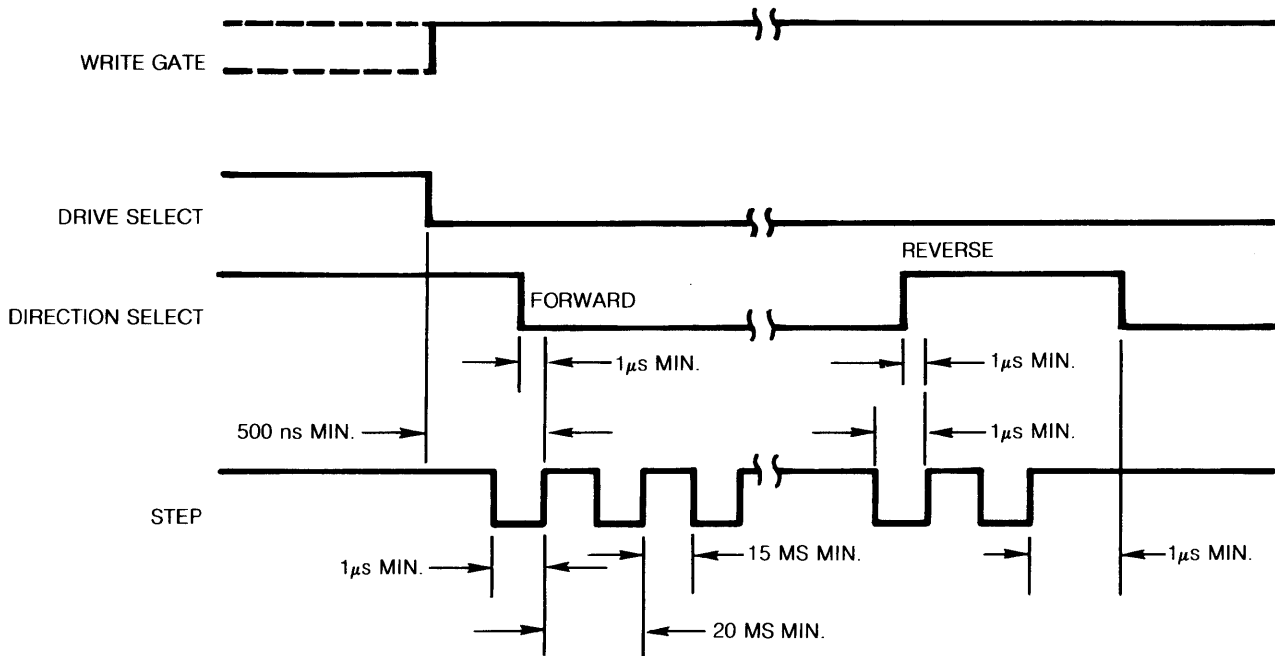

**FIGURE 3. TRACK ACCESS TIMING**

### 3.4.2 Step In

With the DIRECTION SELECT line at minus logic level (0V to .4V), a pulse on the STEP line will cause the read/write heads to move one track closer to the center of the disk. The pulse(s) applied to the STEP line must have the timing characteristics shown in Figure 3.

### 3.5 Side Selection

Head Selection is controlled via the I/O signal line designated SIDE SELECT. A plus logic level on the SIDE SELECT line selects the read/write head on the side 0 surface of the diskette. A minus logic level selects the side 1 read/write head. When switching from one side to the other, a 200 μs delay is required after SIDE SELECT changes state before a read or write operation can be initiated. Figure 4 shows the use of SIDE SELECT prior to a read operation.

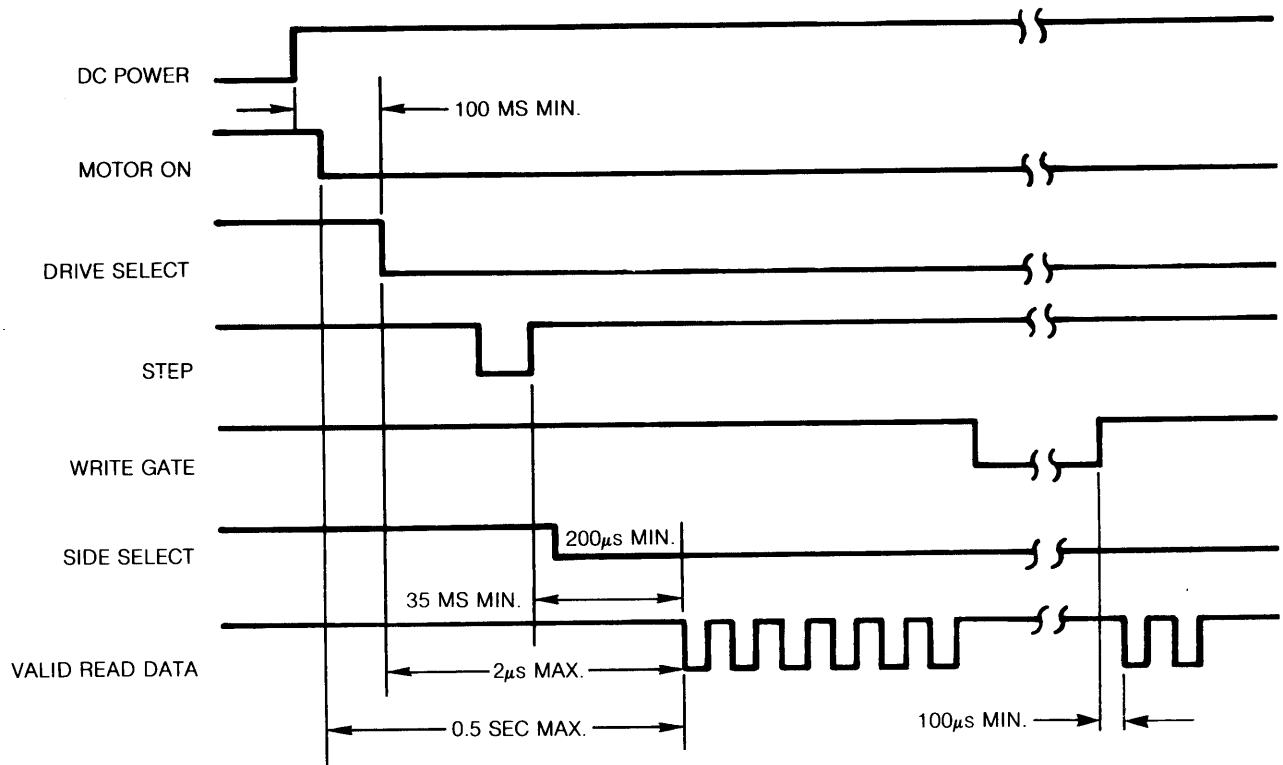

**FIGURE 4. READ INITIATE TIMING**

### 3.6 Read Operation

Reading data from the SA450 minifloppy drive is accomplished by:

- a. Activating DRIVE SELECT line.
- b. Selecting Head.
- c. WRITE GATE being inactive.

The timing relationships required to initiate a read sequence are shown in Figure 4. These timing specifications are required in order to guarantee that the read/write heads position has stabilized prior to reading.

The timing of Read Data (FM) is shown in Figure 5.

The encoding scheme of the recorded data can be either FM or MFM. FM encoding rules specify a clock bit at the start of every bit cell (Refer to Figure 6). MFM encoding rules allow clock bits to be omitted from some bit cells, with the following prerequisites

The clock bit is omitted from the current bit cell if either the preceding bit cell or the current bit cell contains a data bit. See Figure 6.

In the above mentioned encoding schemes, clock bits are written at the start of their respective bits cells and data bits at the centers of their bit cells.

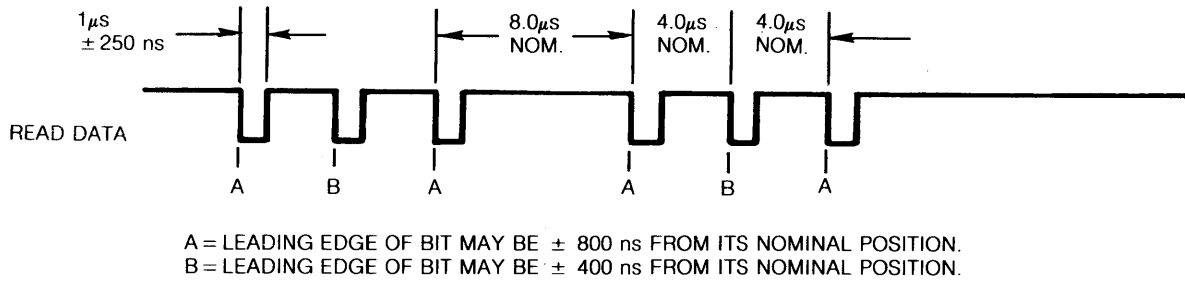

**FIGURE 5. READ DATA TIMING (FM)**

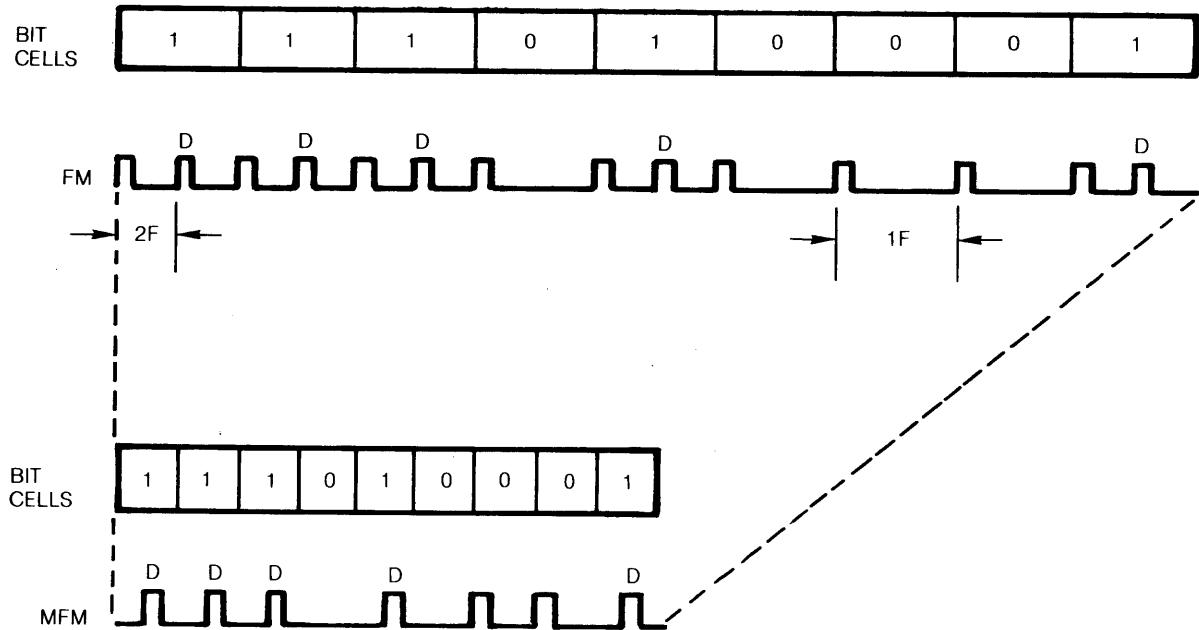

**FIGURE 6. FM AND MFM CODE COMPARISONS**

### 3.7 Write Operation

Writing data to the SA450 is accomplished by:

- Activating the DRIVE SELECT line.
- Selecting Head.
- Activating the WRITE GATE line.
- Pulsing the WRITE DATA line with the data to be written.

The timing relationships required to initiate a Write Data sequence are shown in Figure 7. These timing specifications are required in order to guarantee that the read/write heads position has stabilized prior to writing.

The timing specifications for the Write Data pulses are shown in Figure 8.

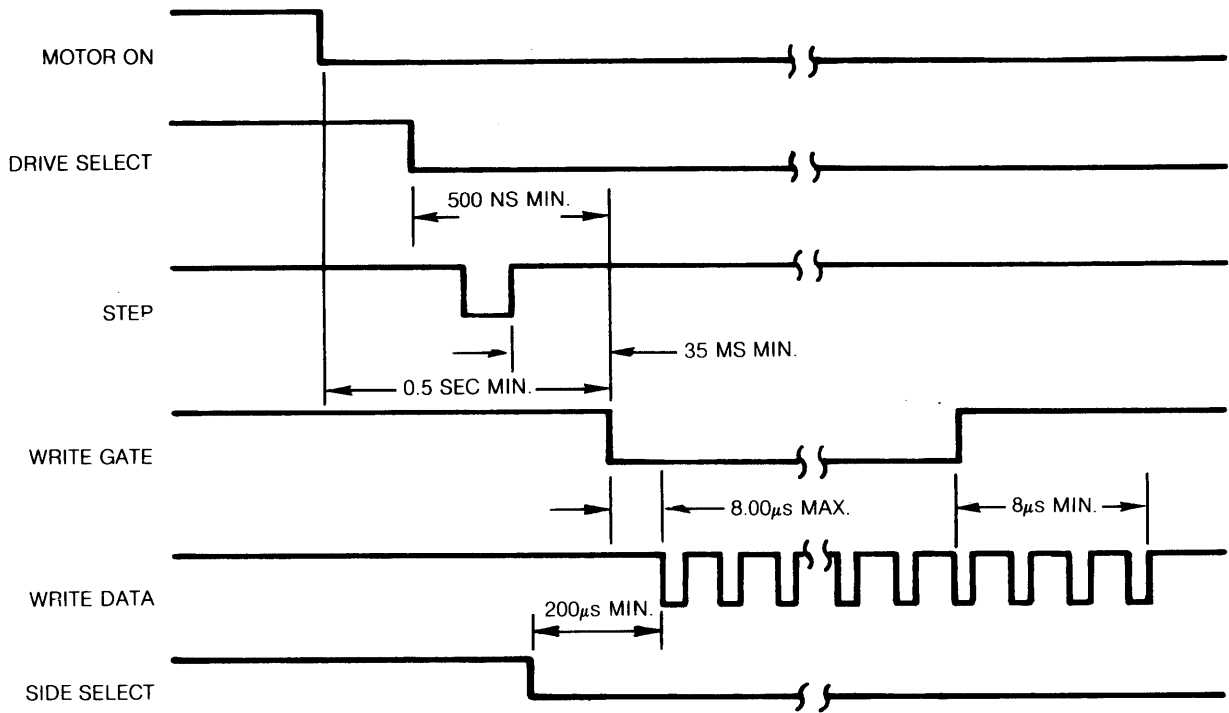

**FIGURE 7. WRITE INITIATE TIMING**

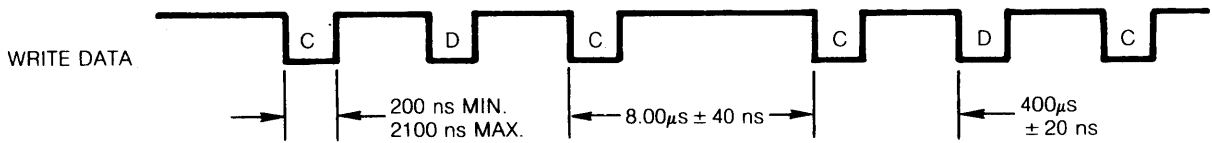
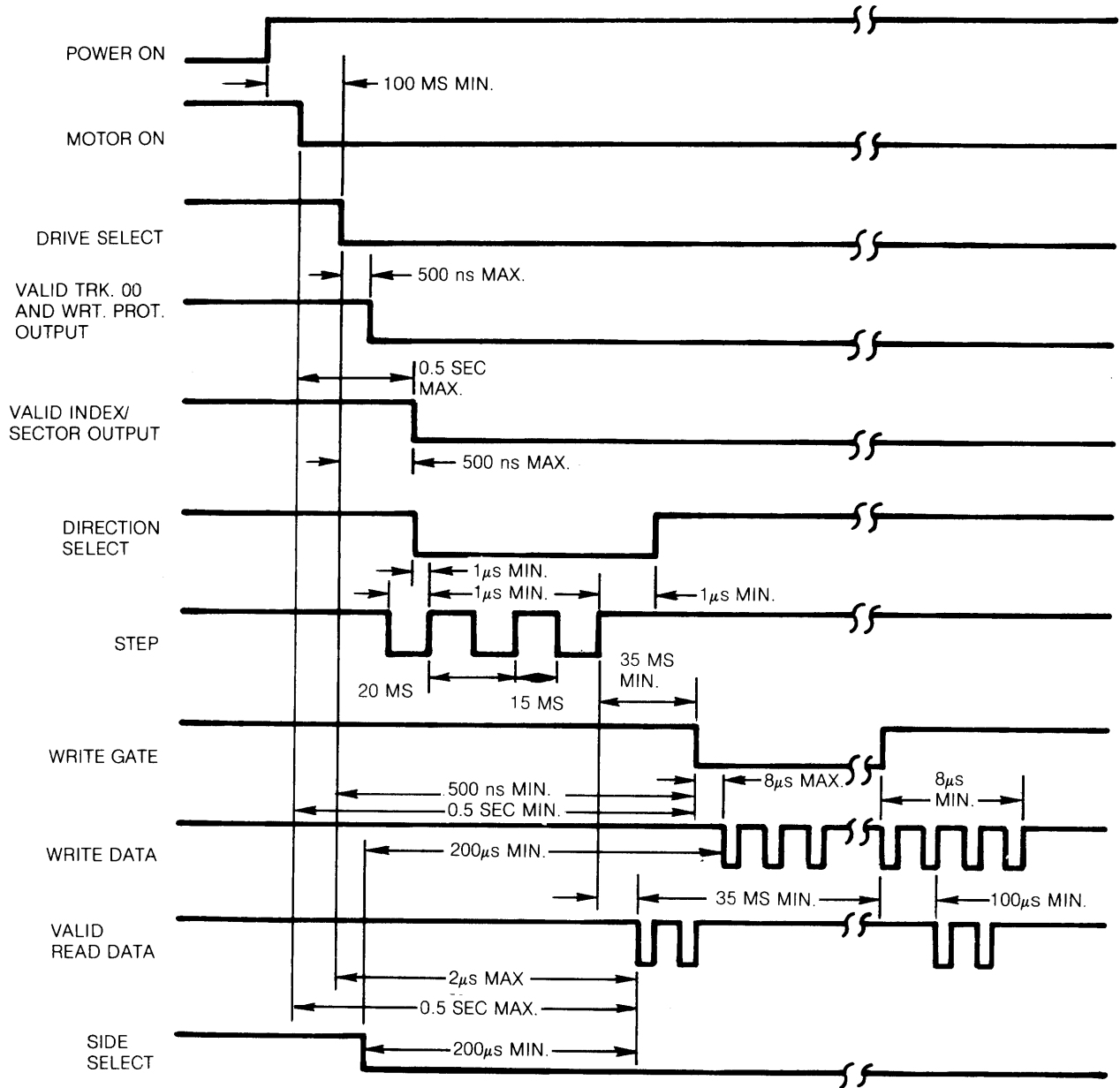

**FIGURE 8. WRITE DATA TIMING (FM)**

Write data encoding can be FM or MFM. The write data should be precompensated 100 ns on all tracks to counter the effects bit shift. The direction of compensation required for any given bit in the data stream depends on the pattern it forms with nearby bits.

### 3.8 Sequence of Events

The timing diagram shown in Figure 9 shows the necessary sequence of events with associated timing restrictions for proper operation.



**FIGURE 9. GENERAL CONTROL AND DATA TIMING REQUIREMENTS**



## 4.0 ELECTRICAL INTERFACE

The interface of the SA450 minidiskette drive can be divided into two categories:

1. Signal
2. Power

The following sections provide the electrical definition for each line.

Refer to figure 10 for all interface connections.

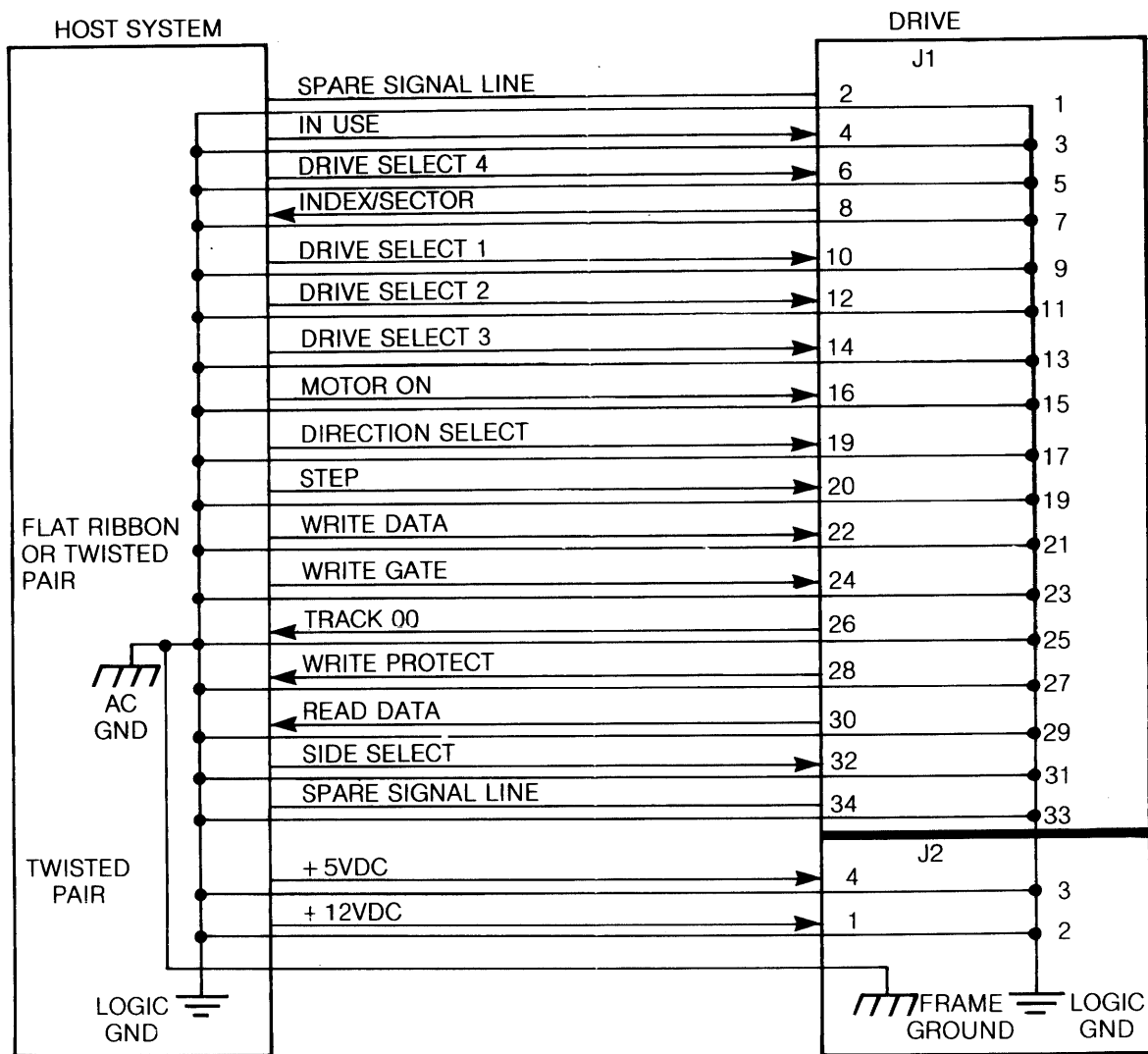

FIGURE 10. INTERFACE CONNECTIONS

## 4.1 Signal Interface

The signal interface consists of two categories:

1. Control
2. Data Transfer

All lines in the signal interface are digital in nature and either provide signals to the drive (input), or provide signals to the host (output), via interface connector P1/J1.

### 4.1.1 Input Lines

The input signals are of 3 types, those intended to be multiplexed in a multiple drive system, those which will perform the multiplexing and those signals which are not multiplexed and affect all the drives in a daisy chain system.

The input signals to be multiplexed are:

1. DIRECTION SELECT
2. STEP
3. WRITE DATA
4. WRITE GATE
5. SIDE SELECT

The input signals which are intended to do the multiplexing are:

1. DRIVE SELECT 1
2. DRIVE SELECT 2
3. DRIVE SELECT 3
4. DRIVE SELECT 4

The signals which are not multiplexed are IN USE and MOTOR ON.

The input lines have the following electrical specifications Refer to Figure 11 for the recommended circuit.

True = Logical zero =  $V_{in} \pm 0.0V$  to  $+4V$  @  $I_{in} = 40\text{ ma}$  (max)

False = Logical one =  $V_{in} + 2.5V$  to  $+5.25V$  @  $I_{in} = 250\mu a$  (open)

Input impedance = 150 ohms

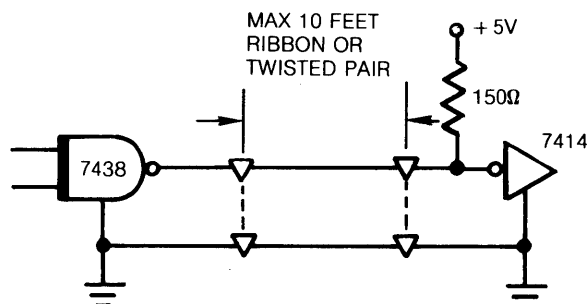

FIGURE 11. INTERFACE SIGNAL DRIVER/RECEIVER

#### **4.1.1.1 Input Line Terminations**

The SA450 has been provided with the capability of terminating the input lines listed below.

1. MOTOR ON
2. DIRECTION SELECT
3. STEP
4. WRITE DATA
5. WRITE GATE
6. SIDE SELECT

These lines are terminated through a 150 ohm resistor pack installed in a dip socket located at IC location 3D.

In a single drive system this resistor pack should be kept in place to provide the proper terminations.

In a multiple drive system (Program Shunt position MX open) only the last drive on the interface is to be terminated. All other drives on the interface must have the resistor pack removed. External terminations may also be used, then the user must provide the terminations beyond the last drive and each of the five lines must be terminated to +5VDC through a 150 ohm 1/4 watt resistor.

#### **4.1.1.2 DRIVE SELECT 1-4**

The SA450 as shipped from the factory is configured to operate in a single drive system. It can be easily modified by the user to operate with other drives in a multiplexed multiple drive system. The user can activate the multiplex option by cutting the MX position of the programmable shunt. This will allow the multiplexing of the I/O lines.

In a single drive system with program shunt positions MX shorted and MS shorted, DRIVE SELECT when activated to a logical zero level, will turn the motor on. Since MX is shorted, the I/O lines are always enabled.

In a multiple drive system (program shunt position MX open) the four input lines (DRIVE SELECT 1, DRIVE SELECT 2, DRIVE SELECT 3 and DRIVE SELECT 4) are provided so that the using system may select which drive on the interface is to be used. In this mode of operation only the drive with its Drive Select line active will respond to the input lines and gate the output lines. In addition, the selected drive will turn its motor on if the program shunt position MS is shorted.

#### **4.1.1.3 MOTOR ON**

This input, when activated to a logical zero level, will turn on the drive motor allowing reading or writing on the drive. A .05 second delay after activating this line must be allowed before reading or writing. This line should be deactivated, for maximum motor life, if no commands have been issued to the drives within two seconds (10 revolutions of the media) after completion of a previous command.

As discussed in section 4.1.1.2, when program shunt position MS is shorted the motor will turn on when the DRIVE SELECT line is activated or if the MOTOR ON line is activated. A user selectable option is available where by the motor will turn on only when the MOTOR ON line is activated. This is accomplished by moving the program shunt over one position in its socket so position MM is shorted.

#### 4.1.1.4 Direction Select

This interface line defines direction of motion the read/write heads will take when the STEP line is pulsed. An open circuit or logical one defines the direction as "out" and if a pulse is applied to the STEP line the read/write heads will move away from the center of the disk. Conversely, if this input is shorted to ground or a logical zero level, the direction of motion is defined as "in" and if a pulse is applied to the STEP line, the read/write heads will move towards the center of the disk.

#### 4.1.1.5 Step

This interface line is a control signal which causes the read/write heads to move with the direction of motion as defined by the DIRECTION SELECT line. This signal must be a logical low going pulse with a minimum pulse width of  $1\mu\text{s}$  and then logically high for 15 ms minimum between adjacent pulses. Each subsequent pulse must be delayed by 20 ms minimum from the preceding pulse.

The access motion is initiated on each logical zero to logical one transition, or the trailing edge of the signal pulse. Any change in the DIRECTION SELECT line must be made at least  $1\mu\text{s}$  before the trailing edge of the STEP pulse. The DIRECTION SELECT logic level must be maintained  $1\mu\text{s}$  after trailing edge of STEP pulse. Refer to Figure 12 for these timings.

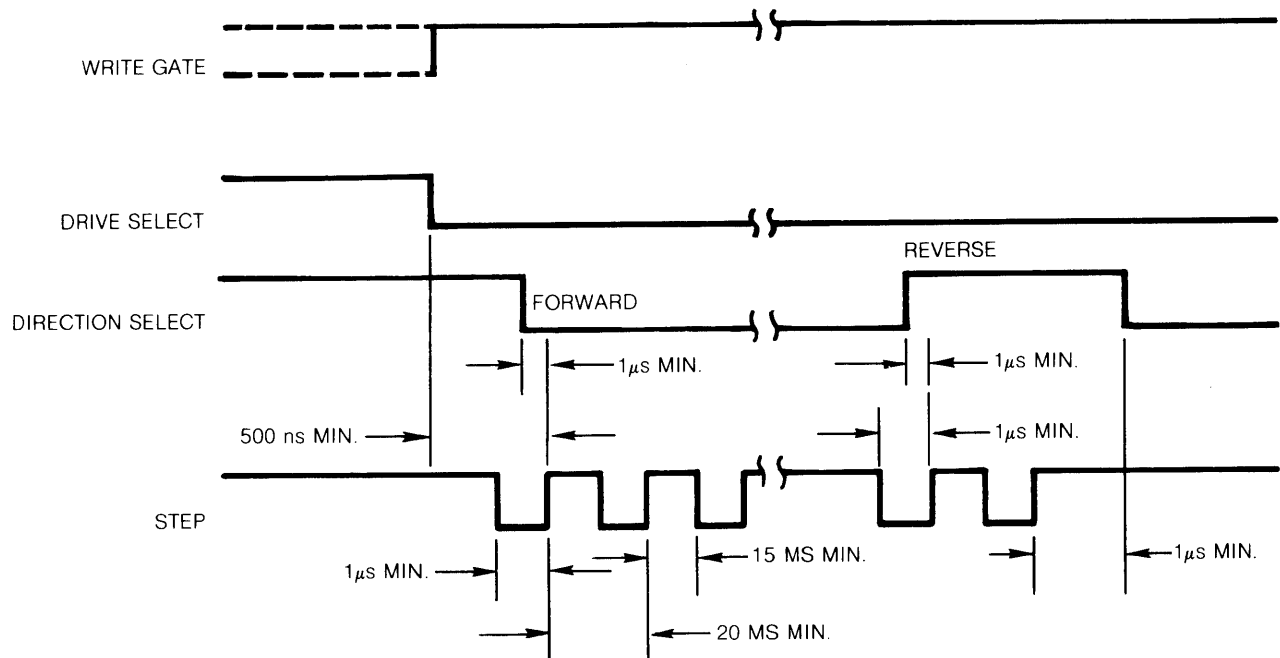

FIGURE 12. STEP TIMING

#### 4.1.1.6 Write Gate

The active state of this signal, or logical zero, enables Write Data to be written on the diskette. The inactive state or logical one, enables the read data logic and stepper logic. Refer to Figure 13 for timings.

#### 4.1.1.7 Write Data

This interface line provides the data to be written on the diskette. Each transition from a logical one level to a logical zero level, will cause the current through the read/write heads to be reversed thereby writing a data bit. This line is enabled by Write Gate being active. Write Data must be inactive during a read operation. A Write Data clamp is provided on the PCB at the interface which holds the WRITE DATA line at a logical zero whenever Write Gate is inactive. Refer to Figure 13 for timings.

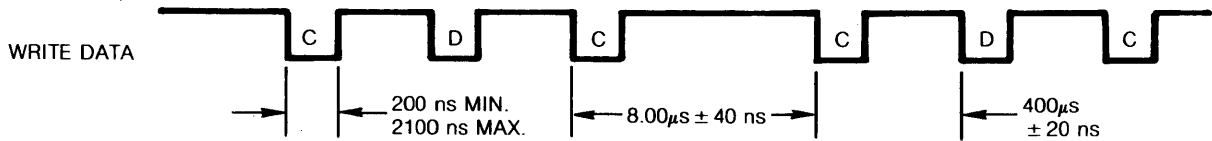

**FIGURE 13. WRITE DATA TIMING**

#### 4.1.1.8 Side Select

This signal defines which side of a two-sided diskette is to be written on to or read from. A logical one selects the side 0 head. When switching from one side to the other a  $200\mu\text{s}$  delay is required before a read or write operation can be initiated.

#### 4.1.1.9 In Use (Option)

Normally, the activity LED on the selected drive will turn on when the corresponding DRIVE SELECT signal is active. The IN USE input can alternately activate the LED on all the drives in a daisy chain or separately in a radial configuration.

#### 4.1.2 Output Lines

The output control lines have the following electrical specifications.

True = Logical zero =  $V_{\text{out}} + 0.0\text{V}$  to  $+ 0.4\text{V}$   
 @  $I_{\text{out}} = 40\text{ ma}$  (max)

False = Logical one =  $V_{\text{out}} + 2.5\text{V}$  (open collector)  
 @  $I_{\text{out}} = 250\mu\text{a}$  max)

#### 4.1.2.1 Track 00

The active or logical zero state of this interface signal indicates when the drive's read/write heads are positioned at track zero (the outermost track) and the access circuitry is driving current through phase "A" of the stepper motor. This signal is at a logical one level, or inactive state, when the drive's read/write heads are not at track zero. When the drive's read/write heads are at track zero and an additional step out pulse is issued to the drive, a mechanical stop will keep the read/write heads at track zero but the TRACK 00 signal will go inactive. This is because the stepper motor will go to phase "C" and not phase "A". One more step out pulse will put the stepper motor back into phase "A" and the TRACK 00 signal will go active again.

#### 4.1.2.2 Index/Sector

This interface signal is provided by the drive each time an index or sector hole is sensed at the Index/Sector photo detector. Normally, this signal is at a logical one level and makes the transition to the logical zero level each time a hole is sensed.

When using SA154 media (Soft Sectored), there will be one pulse on this interface signal per revolution of the diskette (200 ms). This pulse indicates the physical beginning of a track. Refer to Figure 14 for the timing.

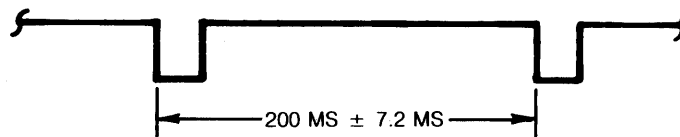

**FIGURE 14. INDEX TIMING (SA154 MEDIA)**

When using SA155 or SA157 media (Hard Sectored), there will be 17 or 11 pulses on this interface line per revolution (200 ms). To indicate the beginning of a track, once per revolution there is one index transition between 16 or 10 equally spaced sector transitions. The timing for these signals is shown in Figure 15 and 16.

When using the Index/Sector signal, look for an edge or transition rather than a level for determining its status. With no diskette inserted, this signal remains active or at a logical zero level which is an erroneous status.

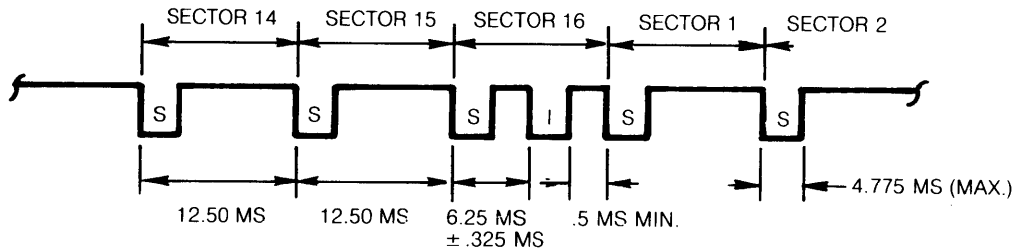

**FIGURE 15. INDEX/SECTOR TIMING (SA155 MEDIA)**

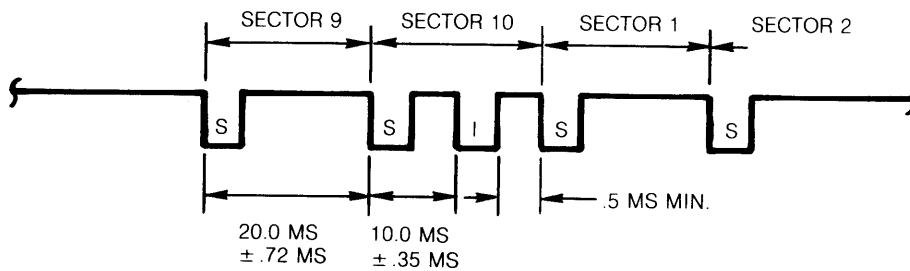

**FIGURE 16. INDEX/SECTOR TIMING (SA157 MEDIA)**

#### 4.1.2.3 Read Data

This interface line provides the "raw data" (clock and data together) as detected by the drive electronics. Normally, this signal is a logical one level and becomes a logical zero level for the active state. Refer to Figure 17 for the timing and bit shift tolerance within normal media variations.

#### 4.1.2.4 Write Protect

This interface signal is provided by the drive to give the user an indication when a Write Protected Diskette is installed. The signal is logical zero level when it is protected. Under normal operation, the drive will inhibit writing with a protected diskette installed in addition to notifying the interface.

### 4.2 Power Interface

The SA450 requires only DC power for operation. DC power to the drive is provided via P2/J2 located on the non-component side of the PCB near the spindle drive motor. The two DC voltages, their specifications and their P2/J2 pin designators are outlined in table 1. The specifications outlined on current requirements are for one drive. For multiple drive systems the current requirements are a multiple of the maximum current times the number of drives in the system.

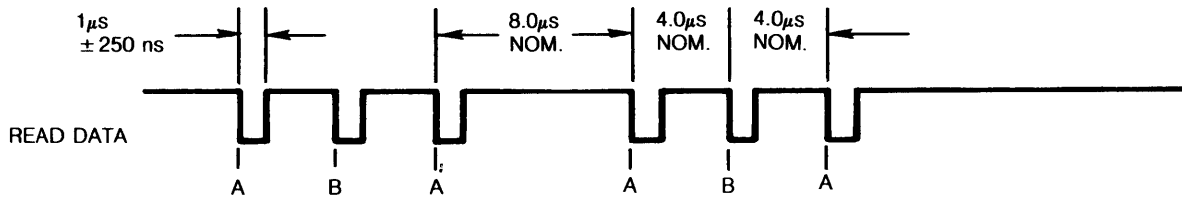

A = LEADING EDGE OF BIT MAY BE  $\pm 800$  ns FROM ITS NOMINAL POSITION.  
 B = LEADING EDGE OF BIT MAY BE  $\pm 400$  ns FROM ITS NOMINAL POSITION.

**FIGURE 17. READ DATA TIMING (FM)**

P2 PIN	DC VOLTAGE	TOLERANCE	CURRENT	MAX RIPPLE (p to p)
1	+ 12VDC	$\pm 0.6$ VDC	1.80 A MAX. .90 A TYP	100 mV max allowable
2	+ 12 Return			
3	+ 5 Return			
4	+ 5VDC	$\pm 0.25$ VDC	.70A MAX .50A TYP.	50 mV max allowable

**TABLE I. DC POWER REQUIREMENTS**

#### 4.2.1 Frame Ground

It is important that the drive be frame grounded to the host system AC or frame ground. Failure to do so may result in drive noise susceptibility.

\*The 12V current is composed of 3 components; Diskette Drive Motor Current, Read/Write stepper functions on the PCB, and Write Erase Current. In the multiplex mode, the drive motor is turned off when the Drive is deselected, but can be turned on by the MOTOR ON interface line.

Each of these functions has the following contribution to the + 12V current requirements:

- A. PCB Read/Write function and Stepper Motor (Drive "Standby" current) + 12V current is .55A typ. ; .7A max.
- B. Diskette Drive Motor Start + 12V current is 1.0A typ, 1.1A max. (motor stalled)
- C. Diskette Drive Motor Running + 12V current is .35A typ, 1.1A max. (motor stalled)





## 5.0 PHYSICAL INTERFACE

The electrical interface between the SA450 and the host system is via two connectors. The first connector, J1, provides the signal interface and the second connector, J2, provides the DC power.

This section describes the physical connectors used on the drive and recommended connectors to be used with them. Refer to Figure 18 for connector locations.

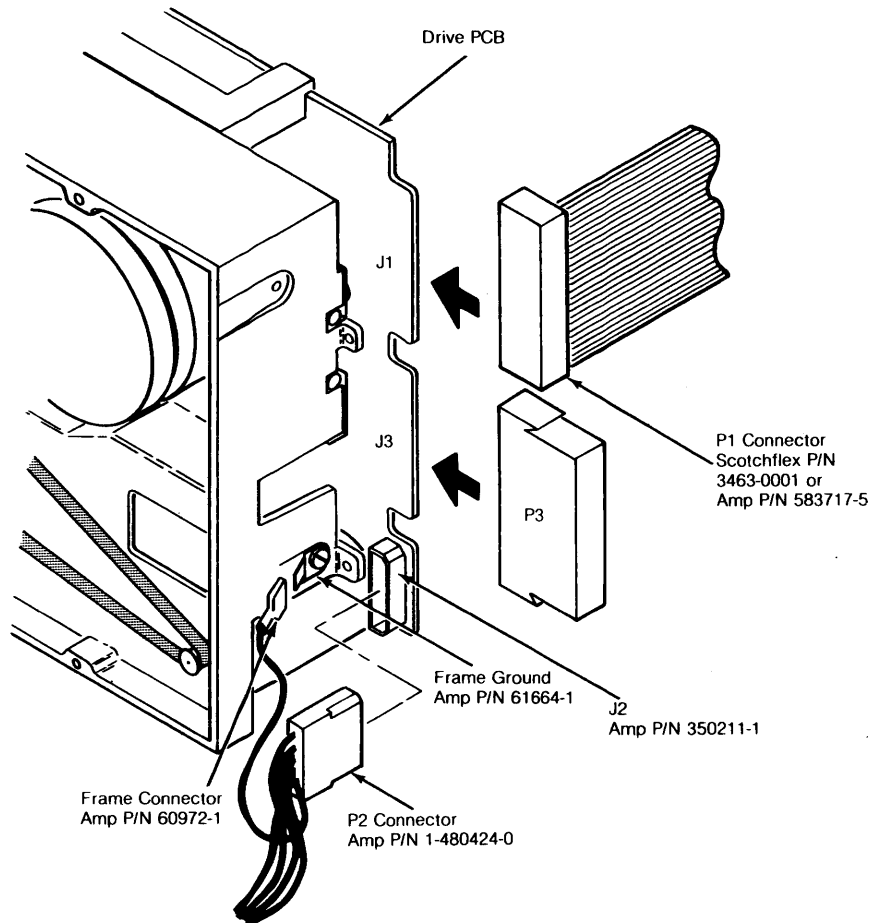

**FIGURE 18. INTERFACE CONNECTORS-PHYSICAL LOCATIONS**

### 5.1 J1/P1 Connector

Connection to J1 is through a 34 pin PCB edge connector. The dimensions for this connector are shown in Figure 19. The pins are numbered 1 through 34 with the even numbered pins on the component side of the PCB and the odd numbered pins on the non-component side. Pin 2 is located on the end of the PCB connector closest to the corner and is labeled 2. A key slot is provided between pins 4 and 6 for optional connector keying.

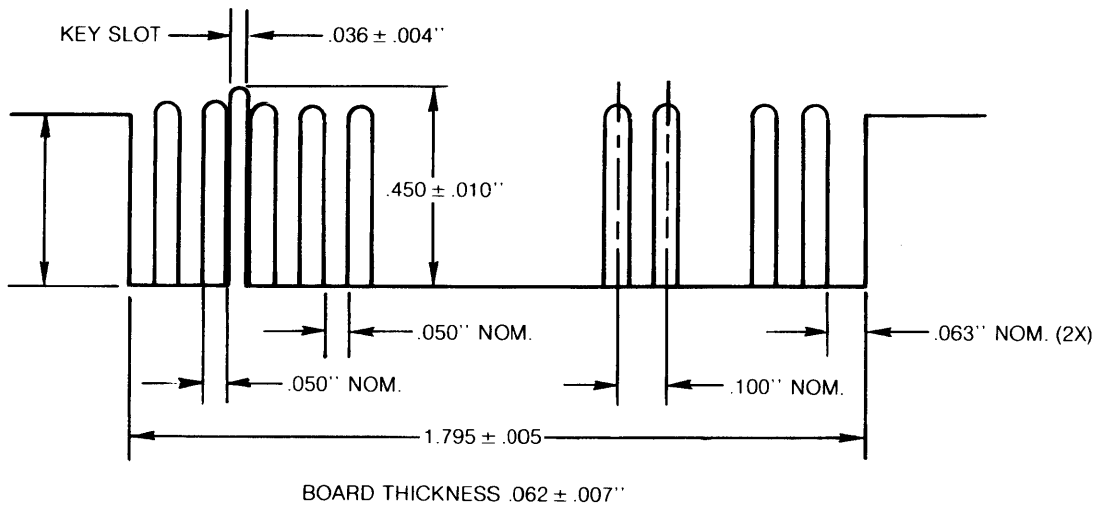

**FIGURE 19. J1 CONNECTOR DIMENSIONS**

### 5.2 J2/P2 Connector

The DC power connector, J2, is mounted on the non-component side of the PCB and is located near the spindle drive motor. J2 is a 4 pin AMP Mate-N-Lok connector P/N 350211-1. The recommended mating connector (P2) is AMP P/N 1-480424-0 utilizing AMP pins P/N 61473-1. J2, pin 1, is labeled on the component side of the PCB. Wire used should be #18 AWG. Figure 20 illustrates J2 connector as seen on the drive PCB from non-component side.

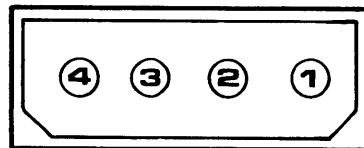

**FIGURE 20. J2 CONNECTOR**

### 5.3 Frame Grounding

The SA450 must be frame grounded to the host system to insure proper operation. If the frame of the drive is not fastened directly to the frame of the host system with a good AC ground, a wire from the system AC frame ground must be connected to the SA450. For this purpose, a faston tab is provided on the drive near the motor control PCB where a faston connector can be attached or soldered. The tab is AMP P/N 61664-1 and its mating connector is AMP P/N 60972-1.

## 6.0 DRIVE PHYSICAL SPECIFICATIONS

This section contains the mechanical dimensions and mounting recommendations for the SA450.

### 6.1 Mechanical Dimensions

Refer to Figure 21 for dimensions of the SA450.

### 6.2 Mounting

As shipped from the factory, the SA450 is capable of being mounted in one of the following positions:

1. Top Loading -mounted upright.
2. Front Loading -mounted vertical with door opening left or right.

-mounted horizontal with PCB up. DO NOT HORIZONTAL MOUNT WITH PCB DOWN.

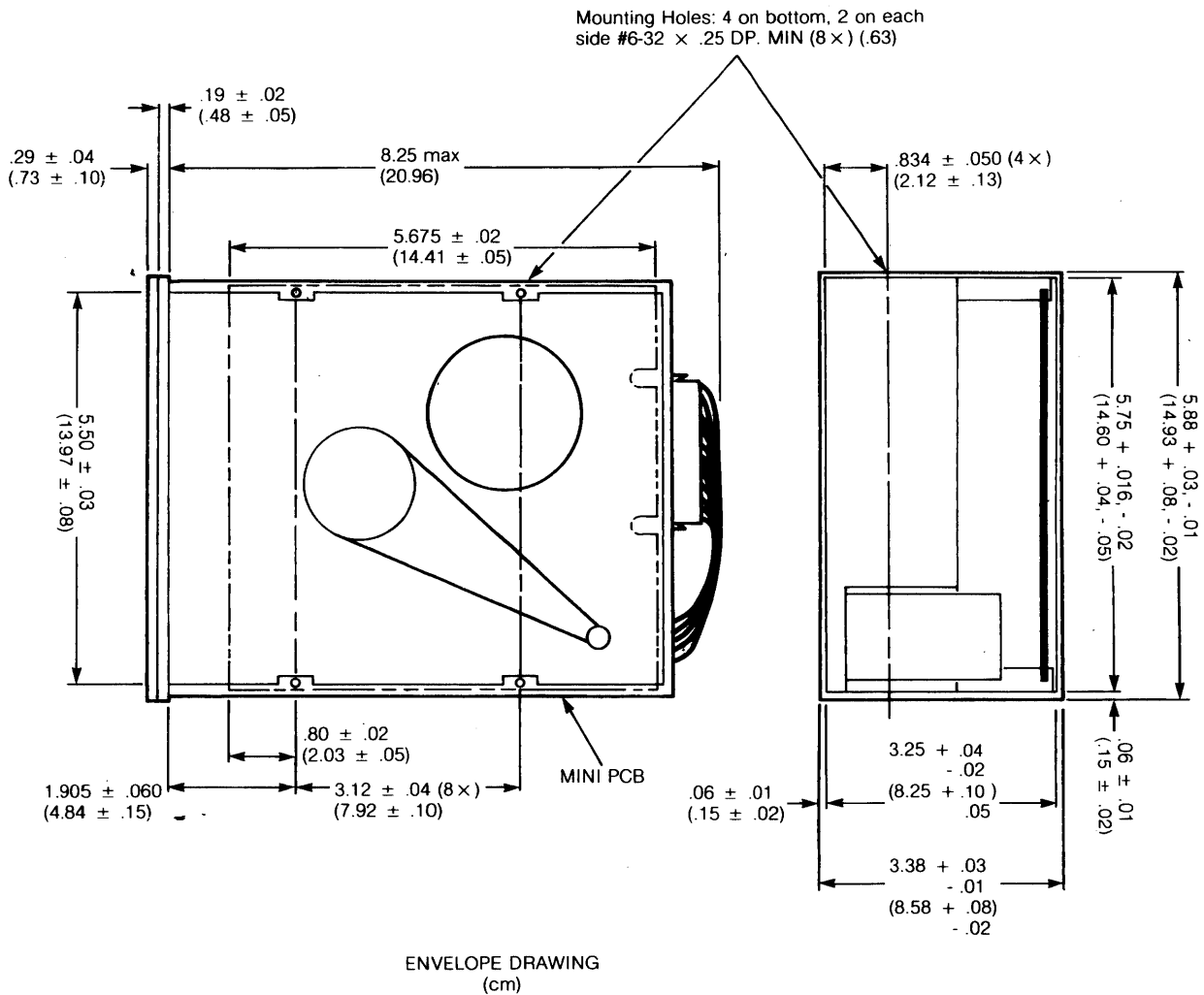

**FIGURE 21. SA450 PHYSICAL DIMENSIONS**

## 7.0 RECORDING FORMAT

### 7.1 General

The format of the data recorded on the diskette is totally a function of the host system. As discussed in Section 3.6, data can be recorded on the diskette using FM or MFM encoding. In these encoding techniques, clock bits are written at the start of their respective bit cells and bits at the centers of their bit cells.

### 7.2 Byte

A Byte, when referring to serial data (being written onto or read from the disk drive), is defined as eight (8) consecutive bit cells. The most significant bit cell is defined as bit cell 0 and the least significant bit cell is defined as bit cell 7. When reference is made to a specific data bit (i.e., data bit 3), it is with respect to the corresponding bit cell (bit cell 3).

During a write operation, bit cell 0 of each byte is transferred to the disk drive first with bit cell 7 being transferred last. Correspondingly, the most significant byte of data is transferred to the disk first and the least significant byte is transferred last.

When data is being read back from the drive, bit cell 0 of each byte will be transferred first with bit cell 7 last. As with reading, the most significant byte will be transferred first from the drive to the user.

Figure 22 illustrates the relationship of the bits within a byte and Figure 23 illustrates the relationship of the bytes for read and write data.

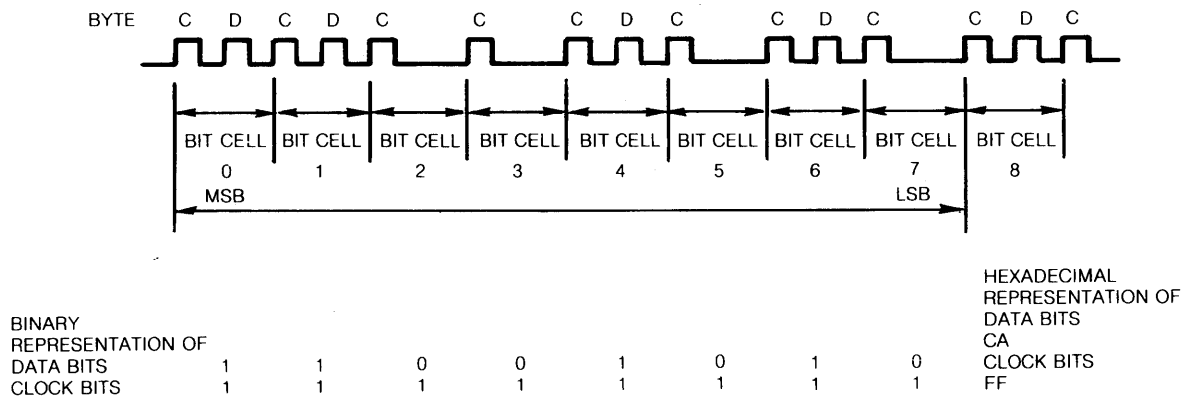

FIGURE 22. BYTE (FM ENCODING)

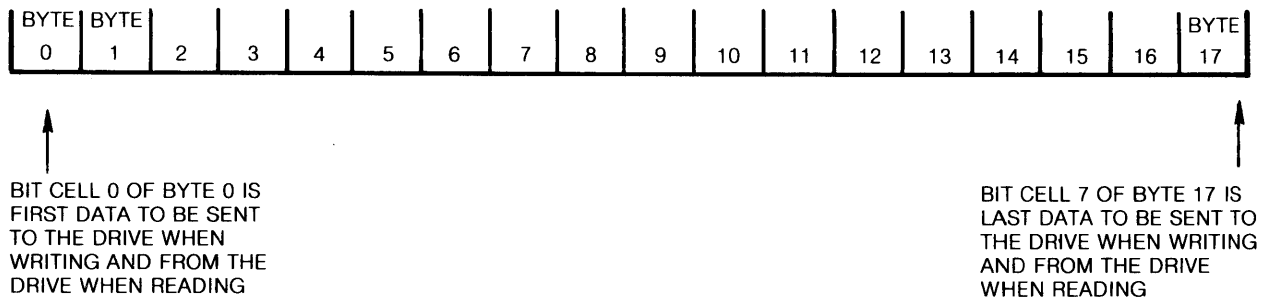

FIGURE 23. DATA BYTES

### 7.3 Formats

Tracks may be formatted in numerous ways and is dependent on the using system. The SA450 can use either hard or soft sectored formats.

#### 7.3.1 Soft Sectored Recording Format

In this format, the using system may record one long record or several smaller records. Each track is started by physical index pulse and then each record is preceded by a unique recorded identifier. This type of recording is called soft sectoring. Figure 24 illustrates the recommended single density (FM) formats. Figure 25 illustrates the recommended double density (MFM) formats.

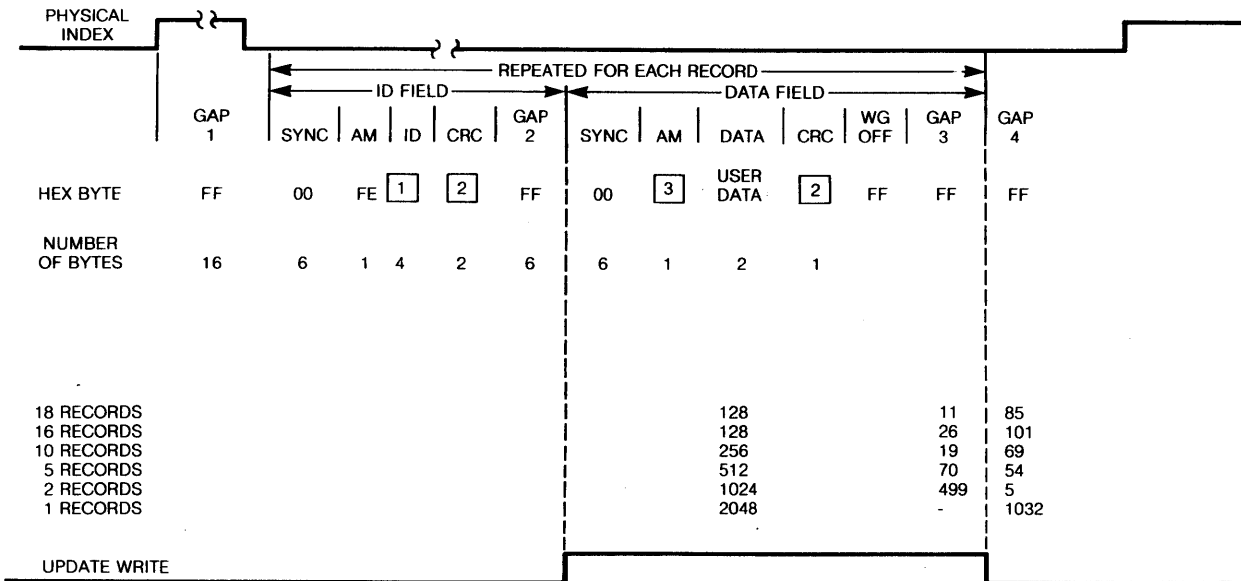

- NOTES: 1. Track Number, Head Number, Sector Number, Sector Length.  
 2. IBM or Equivalent CRC Generator.  
 3. FB for Data or F8 for Deleted Data.

**FIGURE 24. RECOMMENDED SOFT SECTOR SINGLE DENSITY (FM) (EVEN BOUNDARIES)**

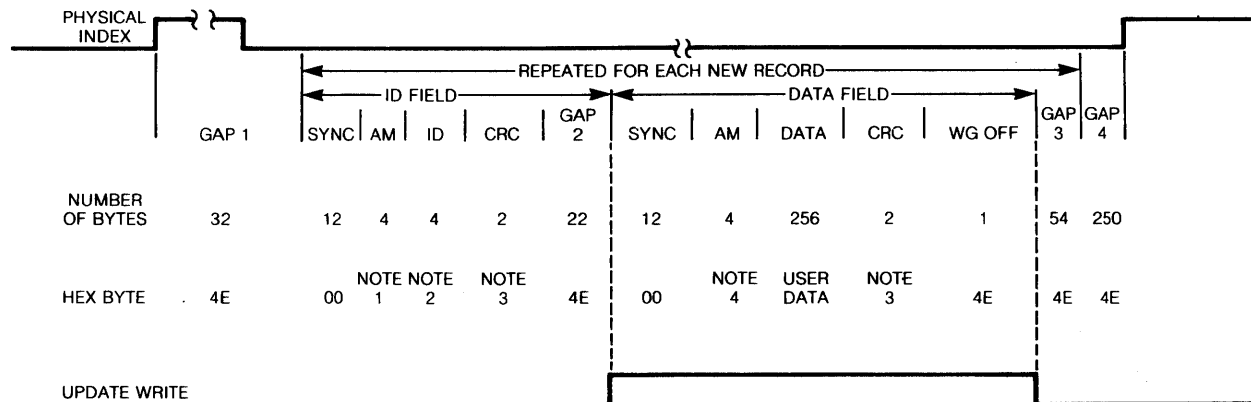

- NOTES: 1. First three bytes are Hex A1 with missing Clock Transitions between bits 4 and 5. Last byte is Hex FE.  
 2. Track Number, Head Number, Sector Number, Sector Length (Hex 01).  
 3. IBM or Equivalent CRC Generator.  
 4. Same as Note 1, except last byte = Hex FB.

**FIGURE 25. MFM RECOMMENDED FORMAT - 256 BYTES/16 RECORDS PER TRACK (IBM TYPE)**

### 7.3.1.1 Track Layout

Index is the physical detector indicating one revolution of the media and is used to initiate format operations, generate the Ready signal in the storage device, insure one complete revolution of the media has been searched, and for a deselect storage device signal after a certain number of revolutions.

- Gap 1-**G1** is from the physical index mark to the ID field address mark sync and allows for physical index variation, speed variation and interchange between storage devices.
- ID Field-**Sync** is a fixed number of bytes for Separator synchronization prior to AM. Includes a minimum of two bytes plus worst case Separator sync up requirements.
  - ID Pre Address Mark** (MFM)-Three bytes of A1 with unique clock bits not written per encode rules.
  - ID Address Mark** (FM)-is a unique byte to identify the ID field and not written per the encode rules.
  - ID Address Mark** (MFM)-is one byte of FE and it is written per the encode rules.
  - ID**-if a four byte address containing track number, head number, record number, and record length.
  - CRC**-is two bytes for cyclic redundancy check.
- Gap 2-**Gap** from ID CRC to data AM sync and allows for speed variation, oscillator variation and erase core clearance of ID CRC bytes prior to write gate turn on for an update write.
- Data Field-**Sync** is a fixed number of bytes for Separator synchronization prior to the AM. Includes a minimum of two bytes plus worst case separator sync up requirements.
  - Pre Data Address Mark** (MFM)-Three bytes of A1 with unique clock bits not written per the encode rules.
  - Data Address Mark**(FM)-is a unique byte to identify the Data Field and it is not written per the encode rules.
  - Data Address Mark** (MFM)-is one byte of FB or F8 and it is written per the encode rules.
  - Data**-is the area for user data.
  - CRC**-is two bytes for cyclic redundancy check.
  - WG OFF** (Write Gate Off)-is one byte to allow for Write Gate turn off after an update write.
- Gap 3-**Gap** from WG OFF to next ID AM sync and allows for erase core to clear the Data Field CRC bytes, speed and write oscillator variation, read preamplifier recovery time and system turn around time to read the following ID Field.
- Gap 4-**G4** is the last gap prior to physical index and allows for speed and write oscillator variation during a format write and physical index variation.

### 7.3.2 Hard Sector Recording Format

In this format, the using system may record up to 16 or 10 sectors (records) per track. Each track is started by a physical index pulse and each sector is started by a physical sector pulse. This type of recording is called hard sectoring. Figure 26 illustrates the hard sectored formats. The SA155 or SA157 minidiskette is to be used for these formats. All drive tolerances have been taken into account in developing these formats.

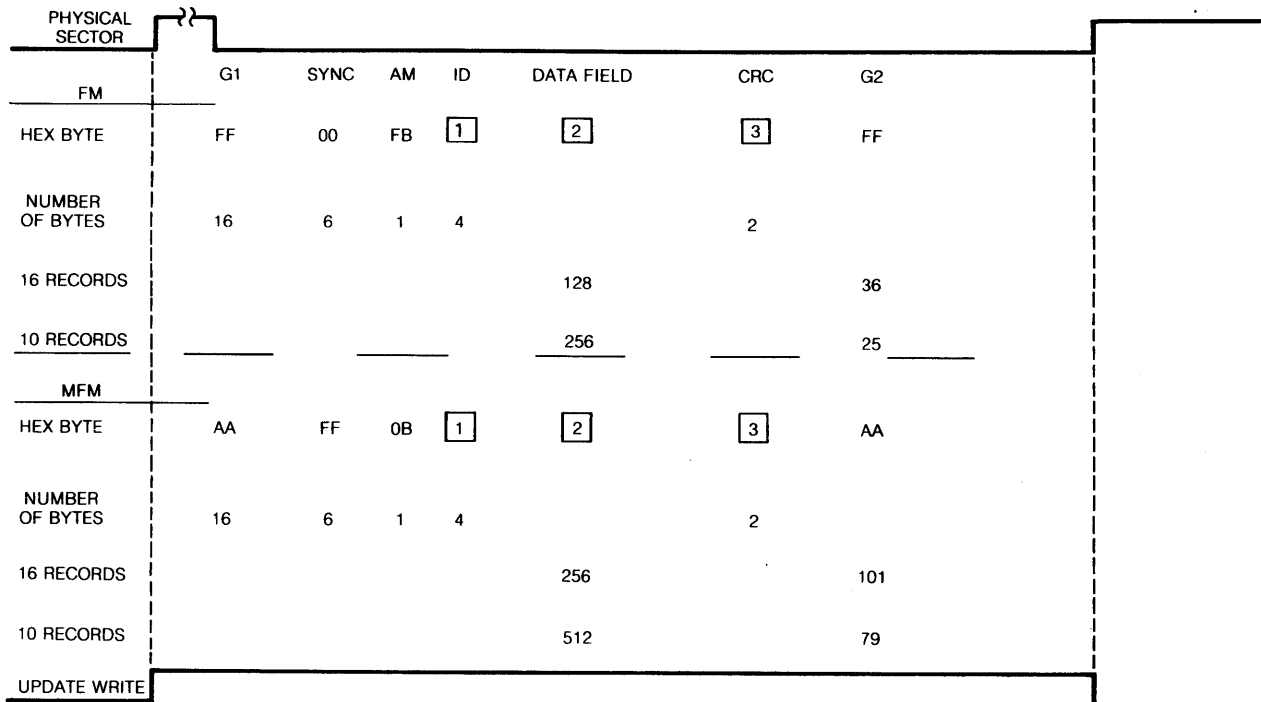

- NOTES: 1. Track Number, Head Number, Record Number, Record Length.  
 2. User Data.  
 3. Generated by CRC Generator (IBM or Equivalent).

**FIGURE 26. RECOMMENDED HARD SECTOR FM AND MFM FORMATS**

## **8.0 OPERATION PROCEDURES**

The SA450 was designed for ease of operator use to facilitate a wide range of operator oriented applications. The following section is a guide for the handling procedures on the minidiskette and minifloppy drive.

### **8.1 Minidiskette Loading**

To load the diskette, open the door on the front panel, insert the diskette with label towards the door handle and close handle. A mechanical interlock prevent door closure without proper media insertion, thus eliminating media damage.

### **8.2 Minidiskette Handling**

To protect the diskette, the same care and handling procedures specified for computer magnetic tape apply. These precautionary procedures are as follows:

1. Return the diskette to its storage envelope whenever it is removed from drive.
2. Do not bend or fold the diskette.
3. Store diskettes not for immediate use in their box.
4. Keep diskettes away from magnetic fields and from ferromagnetic materials which might become magnetized. Strong magnetic fields can distort recorded data on the disk.
5. Replace storage envelopes when they become worn, cracked or distorted. Envelopes are designed to protect the disk.
6. Place I.D. labels in the correct location, never use them in layers.
7. Do not write on the plastic jacket with a lead pencil or ball point pen. Use a felt tip pen.
8. Do not use erasers.
9. Heat and contamination from a carelessly dropped ash can damage the disk.
10. Do not expose diskette to heat or sunlight.





Copyright Shugart

475 Oakmead Parkway Sunnyvale, California 94086  
Telephone: (408) 733-0100 TWX: 910 339 9355 SHUGART SUVL

39013-1 10/80

PRINTED IN U.S.A.