

Assembly Instructions - CT-CA Computer Cursor Control Board

The CT-CA Computer Cursor Control Board is a plug-on option used with the CT-1024 terminal system that provides complete manual and/or computer control of cursor positioning. It is attached to the terminal system by simply plugging it onto jacks J3 and J4 of the main terminal system. Note that either the manual or computer controlled cursor boards may be plugged onto the cursor control jacks, J3 and J4, but only one board may be plugged on at a time. The function of the manual cursor board is to allow incremental positioning of the cursor up, down, left or right. It also provides home-up, erase to end of line (EOL) and erase to end of frame (EOF). The functions are enabled by depressing the appropriate pushbutton switch (7 each which are not being supplied with the kit). The Computer Cursor Control Board has the same functions, but may also be controlled by the computer with ASCII control characters.

The circuitry provides the switch debouncing necessary to prevent multiple cursor counting thus insuring the cursor jumps only one position each time a directional button is depressed. The control switches themselves are SPST normally open pushbutton switches. The debouncing delay provided is 100 milliseconds, but longer delays can be achieved by making electrolytic capacitor C1 larger. The entire circuit is built up on a 3 1/16" x 4 1/2" fibreglass circuit board which is plugged onto the main board on connector strips J3 and J4 just behind the memory board. Switch connections to the cursor board are provided on the nine pin connector attached to its circuit board.

PC Board Assembly

NOTE: Since all of the holes on the PC board have been plated thru, it is only necessary to solder the components from the bottom side of the board. The plating provides the electrical connection from the "BOTTOM" to the "TOP" foil of each hole. It is important that none of the connections be soldered until all of the components of each group have been installed on the board. This makes it much easier to interchange components if a mistake is made during assembly. Be sure to use a low wattage iron (not a gun) with a small tip. Do not use acid core solder or any type paste flux. We will not guarantee or repair any kit on which either product has been used. Use only the solder supplied with the kit or a 60/40 alloy resin core equivalent. Remember all of the connections are soldered on the bottom side of the board only.

(✓) Attach all of the resistors to the board. As with all other components unless noted, use the parts list and component layout drawing to locate each part and install from the "TOP" side of the board bending the leads along the "BOTTOM" side of the board and trimming so that 1/16" to 1/8" of wire remains. Solder.

(✓) Install all of the capacitors on the board. Be sure to orient the electrolytic capacitors correctly. The polarity is indicated on the component layout drawing. Solder.

- 1) Install the transistor and diode on the board. The diode must be turned so the banded end corresponds with that shown on the component layout drawing, and the transistor must be turned so its lead configuration matches with that of the board. Leave a 1/4" space between the transistor case and the circuit board. Solder.
- 2) Install all of the intergrated circuits on the board being very careful to install each in its correct position. Do not bend the leads on the back side of the board. Doing so makes it very difficult to remove the integrated circuits should replacement ever be necessary. The semicircle notch on the end of the package is used for reference and should match with that shown on the component layout drawing for each of the IC's. Make sure the integrated circuits are down firmly against the board and solder.
- 3) Now attach the two ten pin female connectors to the board. These must be installed from the "TOP" side of the board and pressed down so the connectors seat firmly against the board. Solder.
- 4) Attach the 9 pin connector JMC-1 to the circuit board from the "TOP" side making sure to orient it exactly as shown in the component layout drawing. Note that the connector already has the pins installed. Make sure all of the pins are firmly against the nylon support. They can work loose when pressing the connector onto the board. Solder.
- 5) Now that most of the components have been installed on the board, double check to make sure that all have been installed correctly in their proper location.
- 6) Now check very carefully to make sure that all components have been soldered. It is very easy to miss some connections when soldering which can really cause some hard to find problems later during the check out phase. Also check for solder "bridges" and "cold" solder joints which are also a common problem.
- 7) Looking at the board from the "TOP" side with the connectors at the bottom, press the nylon indexing plug into the second pin from the right on the left connector (J3 pin 9).
- 8) Do not install jumpers on the board at this time.
- 9) This completes the circuit board assembly phase of the instructions. This board should not be installed onto the main terminal board until the main board itself is working and has been completely checked out according to the checkout phase of the terminal assembly instructions.

Manual Cursor Control Switch Wiring

The following steps should be followed if you wish to wire in pushbutton switch to allow manual control of the cursor. If you do not wish to install the switches permanently you can ground the proper pins at JMC-1 one at a time for the checkout procedure described in the "Final Assembly" section.

- () All of the cursor control switches are connected to the cursor board through connector JMC-1. Mount your normally open SPST pushbutton control switches wherever you wish, preferably near the operator. Wire them so that when the switch is depressed, the appropriate control function pin is grounded. The #22 or heavier gauge wires terminating at the JMC-1 connector must have the appropriate connector pins attached and soldered as per the table below. All of the pins should be female except those connecting to pins 3, 4 and 9 which are male.

<u>PIN NUMBER</u>	<u>PIN TYPE</u>	<u>FUNCTION</u>
1	FEMALE	CURSOR RIGHT
2	FEMALE	CURSOR UP
3	MALE	CURSOR DOWN
4	MALE	ERASE TO EOF
5	FEMALE	ERASE TO EOL
6	FEMALE	CURSOR LEFT
7	FEMALE	NO CONNECTION
8	FEMALE	GROUND
9	MALE	HOME UP

- () Snap each of the above mentioned pins into the 9 pin nylon housing from the numbered side using the table above. Make sure to snap the correct pin into its correct location. Note that the nylon connector block is marked with the assigned pin numbers. The intermixed pins provide the indexing necessary for proper orientation.

Final Assembly

- () First of all remove power from your main terminal board.
- () Orient your cursor board so the "TOP" side of the board faces toward the main terminal's memory board, and press the board down onto connectors J3 and J4. If your indexing plug was installed correctly and the board is oriented correctly, the cursor board should go on easily.
- () Now plug on connector JMC-1 and apply power to the system. As each switch is depressed (or each respective pin of JMC-1 is grounded) the appropriate function should be executed. If not, disconnect power immediately, remove the board and check the cursor board over carefully for solder "bridges" and "cold" solder joints. If you do not find the problem here revert back

to the main terminal board instructions where the cursor positioning functions are tested and check to make sure the cursor circuitry on the main board is functioning properly. Install jumpers A through K after the manual cursor portion of the circuit is checked out and functioning properly. Read how it works before deciding on which jumpers to install.

Cursor Control Functional Descriptions

- CURSOR UP - Moves the cursor up one line each time the switch is depressed, unless the cursor is already on the top line in which case the cursor jumps to the bottom line.
- CURSOR DOWN - Moves the cursor down one line each time the switch is depressed, unless the cursor is already on the bottom line in which case the cursor jumps to the top line.
- CURSOR LEFT - Moves the cursor left one position each time the switch is depressed, unless the cursor is already in the left most character position in which case the cursor jumps to the right most character position.
- CURSOR RIGHT - Moves the cursor right one position each time the switch is depressed, unless the cursor is already in the right most character position in which case the cursor jumps to the leftmost character position.
- HOME UP - Positions the cursor to the upper leftmost position on the screen.
- ERASE EOF - Erases from the cursor position to the end of the screen on the page of data being displayed.
- ERASE EOL - Erases from the cursor position to the end of the line on the page of data being displayed.

To test your unit install the following jumpers:

A to <u>5</u>	F to 2
B to <u>4</u>	G to 5
C to 3	H to 4
D to 0	J to 6
E to 1	K to 7

Install the cursor board in your terminal and apply power. The following functions should be executed:

CTRL S gives HOME UP

CTRL P gives CURSOR RIGHT
 CTRL Q gives CURSOR DOWN
 CTRL R gives CURSOR LEFT
 CTRL U gives CURSOR UP
 CTRL T gives ERASE END OF LINE
 CTRL V gives ERASE END OF FRAME
 CTRL W gives START READ (if terminal is equipped with screen read)

When making the above tests with a serial interface installed be sure to have the terminal set up for an ECHO mode. (Either the serial interface jumpered for ECHO or an ECHO through a computer).

If the above functions are not implemented correctly remove power and discontinue use until the problem is found.

Programming the Computer Controlled Cursor

The computer control portion of this board has a BCD Decoder that activates the same control functions as the manual switches. It has an extra decoded output that is used for START READ, or for any other function that requires a negative pulse such as STOP READ. The START READ is implemented on the board. All other extra functions must be implemented by the user with jumpers to spare pins of J3 and J4.

All selected codes must fall within one of the four groups of control codes and selected by jumpers as follows:

<u>JUMPER</u>	<u>B TO $\bar{4}$</u>	<u>B TO 4</u>
A TO $\bar{5}$	"000" ₈ TO "007" ₈	"010" ₈ TO "017" ₈
A TO 5	"020" ₈ TO "027" ₈	"030" ₈ TO "037" ₈

A brief table of which jumpers to install for your particular needs is given on the next page. For example to generate the CURSOR UP command from a NAK command jumper A to 5, B to 4 and G to 5. A control U would then generate a CURSOR UP.

Remember that you can work only in one group of eight control commands at a time; you cannot mix them. Also note that there are two 4 and two 5 points on

Programming Table - Computer Controlled Cursor

JUMPERS		OCTAL	HEX	BINARY OUTPUT CODE B1 - B7	CHARACTER
A to <u>5</u> and B to <u>4</u>	FN to 0	000	00	0000000	NUL
	FN to 1	001	01	0000001	SOH <i>C/A</i>
	FN to 2	002	02	0000010	STX <i>C/B</i>
	FN to 3	003	03	0000011	ETX
	FN to 4	004	04	0000100	EOT
	FN to 5	005	05	0000101	ENQ
	FN to 6	006	06	0000110	ACK
	FN to 7	007	07	0000111	BEL
A to <u>5</u> and B to <u>4</u>	FN to 0	010	08	0001000	BS
	FN to 1	011	09	0001001	HT
	FN to 2	012	0A	0001010	LF
	FN to 3	013	0B	0001011	VT
	FN to 4	014	0C	0001100	FF
	FN to 5	015	0D	0001101	CR
	FN to 6	016	0E	0001110	SO
	FN to 7	017	0F	0001111	SI
A to <u>5</u> and B to <u>4</u>	FN to 0	020 →	<i>C/P</i> 10	0010000	DLE
	FN to 1	021 ↓	<i>C/Q</i> 11	0010001	DC1
	FN to 2	022 ←	<i>C/R</i> 12	0010010	DC2
	FN to 3	023 <i>H</i>	<i>C/S</i> 13	0010011	DC3 ← <i>H</i>
	FN to 4	024 <i>EEL</i>	<i>C/T</i> 14	0010100	DC4
	FN to 5	025 ↑	<i>C/U</i> 15	0010101	NAK
	FN to 6	026 <i>EEF</i>	16	0010110	SYN ← <i>EEF</i>
	FN to 7	027	START R. 17	0010111	ETB
A to <u>5</u> and B to <u>4</u>	FN to 0	030	18	0011000	CAN
	FN to 1	031	19	0011001	EM
	FN to 2	032	1A	0011010	SUB
	FN to 3	033	1B	0011011	ESC
	FN to 4	034	1C	0011100	
	FN to 5	035	1D	0011101	
	FN to 6	036	1E	0011110	
	FN to 7	037	1F	0011111	RS

FN is the respective point corresponding to the following:

POINT

- C HOME UP
- D CURSOR RIGHT *C/S* - *3*
- E CURSOR DOWN *C/X* - *LAW*
- F CURSOR LEFT *C/A* - *3*
- G CURSOR UP *C/W* - *3*
- H ERASE TO END OF LINE
- J ERASE TO END OF FRAME (PAGE)
- K START SCREEN READ

the board. The A and B jumpers go to the nearest 4 and 5 when a jumper to these points is required.

Notice to Serial and Parallel Interface Users

For those of you who have your CT-1024 connected to a computer through a serial or parallel interface please note the following comments:

Serial Interface: The ERASE functions take time to perform and could cause problems at 600 and 1200 baud. One RUB OUT following an erase command for 600 baud and two RUB OUTS for 1200 baud will help kill time for you. The RUB OUTS may cause a question mark to be displayed occasionally. If this is objectionable use two SPACES followed by two BACK CURSOR commands.

Parallel Interface: Program a 30 millisecond wait loop after each erase function. Do not send out either NULL or RUB OUTS to kill time.

How it Works (Manual Cursor Section)

Since all of the pushbutton control switches are normally open, the switch inputs are all tied high with resistors R1 - R7. The inputs are directed to the output NAND gates (IC1 and IC6A, IC6B, IC6C) through inverters IC5 and IC6D. Note that none of the control switches affect the output gates unless the gating from IC2 is high. IC4 monitors the control switches and goes high when any one of the seven switches is depressed. This immediately sets the Q output of IC2A low where it will remain for approximately 100 milliseconds at which time Q will go high again. This then fires IC2B forcing its Q output high for 1 microsecond gating the appropriate control command onto the TV typewriter circuitry. Transistor Q1 advances the cursor position horizontally when it is activated by the screen read option if it is used.

How It Works (Computer Control Section)

The ASCII code is a seven bit code with an eight bit that is normally used for parity check. This code is often defined in octal form as a three digit number. The null code is all zero's and defined in octal as "000"8. The rub out is all one's, and is defined as "177"8. The codes defined as control codes have both bits 6 and 7, as zero's, i.e. all codes from "000"8 to "037"8 are control codes. Some of these codes are; "012"8 line feed and "015"8 carriage return.

The "A" and "B" jumpers select bit "4" and bit "5" of the ASCII code respectively. IC-7 and IC-8 generate a 200 nanosecond pulse if both bits 6 and 7 equal "0" and bits "4" and "5" are as selected by jumpers "A" and "B". This pulse is used as an activate signal for IC-3. IC-3 monitors the bit 1, bit 2,

and bit 3 input line. It outputs a pulse on one of the eight decoded outputs for the duration of the activate signal on pin 12. The pulse may be connected to any control function pad by the use of jumpers. A suitable TTL data book should be consulted for a truth table for IC3. The numbered pads marked 0 through 7 correspond to the octal notation of the least significant digit of the control code.

In Case of Problems

If you have problems on some phase of operation of the manual cursor portion of the board, the best recommendation is to remove power and recheck your assembly over very carefully with the instructions. If you still cannot find the problem and feel secure in your understanding of digital circuits, you can troubleshoot the unit with an oscilloscope. This does, however, require a thorough understanding of how the unit works as is described in the "how it works" section. If you are still not able to locate the problem or prefer not to service the unit yourself, please consult us before sending the unit in for repairs.

Repairs will be done for a basic rate charge plus parts. The basic rate for the computer controlled cursor board CT-CA is \$5.00. If you must return your board send \$5.00 in the form of a money order or cashiers check along with the board. When repairs are finished the board will be returned to you COD for parts charges, if any. Do not send personal checks for repair work.

Pack all parts to be returned carefully and insure. We will not accept delivery on any parcels that arrive in damaged condition. Make check or money order payable to Southwest Technical Products Corporation.

Parts List - Computer Cursor Board

Resistors

R1 - R7, R9, R12 - R14	1K ohm 1/4 watt resistor
R10, R11	5.6K ohm 1/4 watt resistor
R8	2.2K ohm " " "

Capacitors

C1	33 mfd @6 VDC electrolytic capacitor
C2, C3, C4, C5	100 pfd polystyrene capacitor
C6	0.1 mfd disc capacitor

Semiconductors

D1	1N4148/1N914 silicon diode or equiv.
IC1, IC6	7403 quad NAND gate (open collector)
IC2	74123 dual one shot
IC4	7430 8 input NAND gate
IC5, IC8	7404 hex inverter
Q1	2N5129 silicon transistor
IC3	7445 BCD decoder
IC7	7400 quad NAND gate

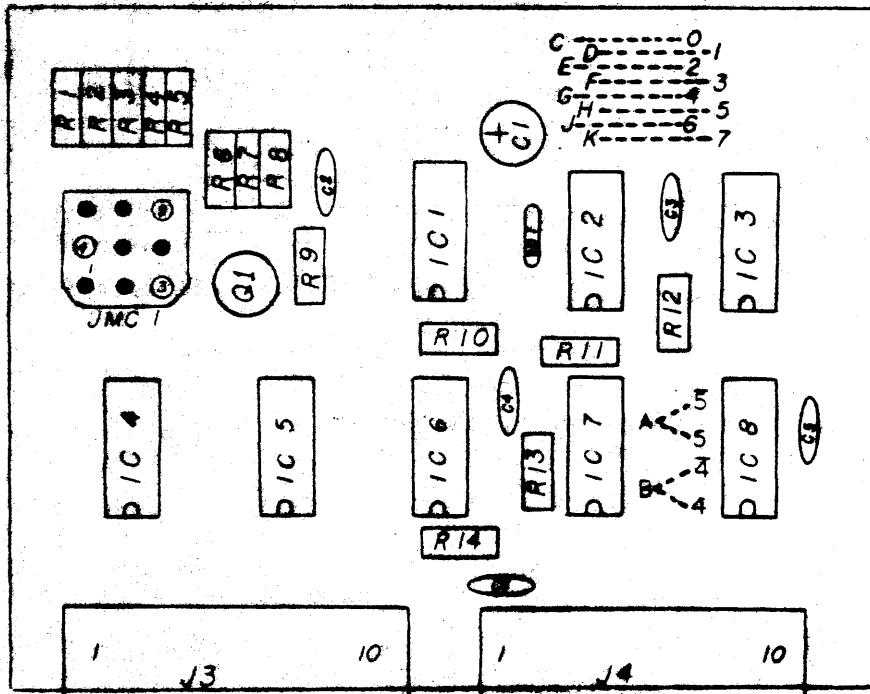

PC Top Layout - Computer Controlled Cursor Board

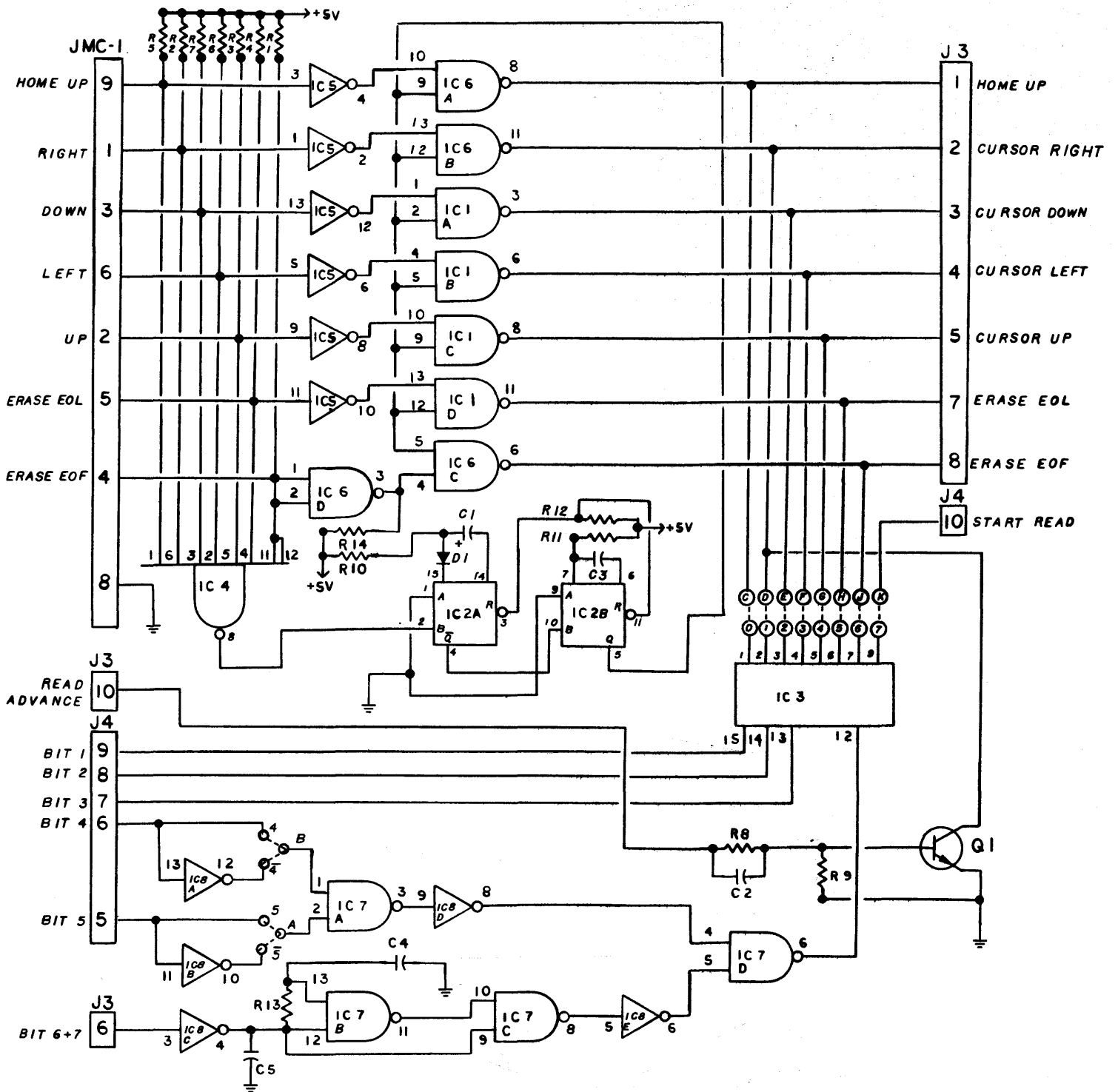

Schematic - Computer Controlled Cursor Board