

**DISK DRIVE
USER'S GUIDE
FCC COMPLIANT**

PB9901-9041-007

WARNING

This equipment generates, uses, and can radiate radio frequency energy and if not installed and used in accordance with the instructions manual may cause interference to radio communications. It has been tested and found to comply with the limits for a Class A computing device pursuant to Subpart J or Part 15 of FCC Rules, which are designed to provide reasonable protection against such interference when operated in a commercial environment. Operation of this equipment in a residential area is likely to cause interference in which the user at his own expense will be required to take whatever measures may be required to correct the interference.

This digital apparatus does not exceed the Class A limits for radio noise emissions from digital apparatus as set out in the Radio Interference Regulations of the Canadian Department of Communications.

Le present appareil numerique n'emt pas de bruits radioelectriques depassant les limites applicables aux appareils numeriques de Class A, prescrites dans le reglement sur le brouillage radioelectrique edicte par le Ministere des Communicatios du Canada.

PROPRIETARY STATEMENT

System Industries has prepared this manual for use by System Industries personnel, licensees, and customers. The information contained herein is the property of System Industries and shall neither be reproduced in whole nor in part without prior written approval from System Industries.

System Industries reserves the right to make changes, without notice to the specifications and materials contained herein, and shall not be responsible for any damages (including consequential) caused by reliance on the material as presented, including, but not limited to, typographical, arithmetic, and listing errors.

VAX, VMS, DEC, ULTRIX, MicroVAX, QBus, and UNIBUS are all trademarks of Digital Equipment Corporation.

REVISION RECORD

REVISION NUMBER	DATE	DESCRIPTION	EO NUMBER
01	07/19/84	Initial Release	2498
02	06/13/85	Addition of SI9722 and SI9798 disk drives	2997
03	05/15/86	Addition of SI9733, 9761, 9722/9733 disk drives	3739
04	12/04/86	Third Revision	4182
E	04/02/87	Change in illustrations (Figures 2-8 and 2-9)	4400
F	05/14/87	Change in setting (Section 7.4 onpage 7-7)	4493
007	12/22/89	Technical Corrections	6328

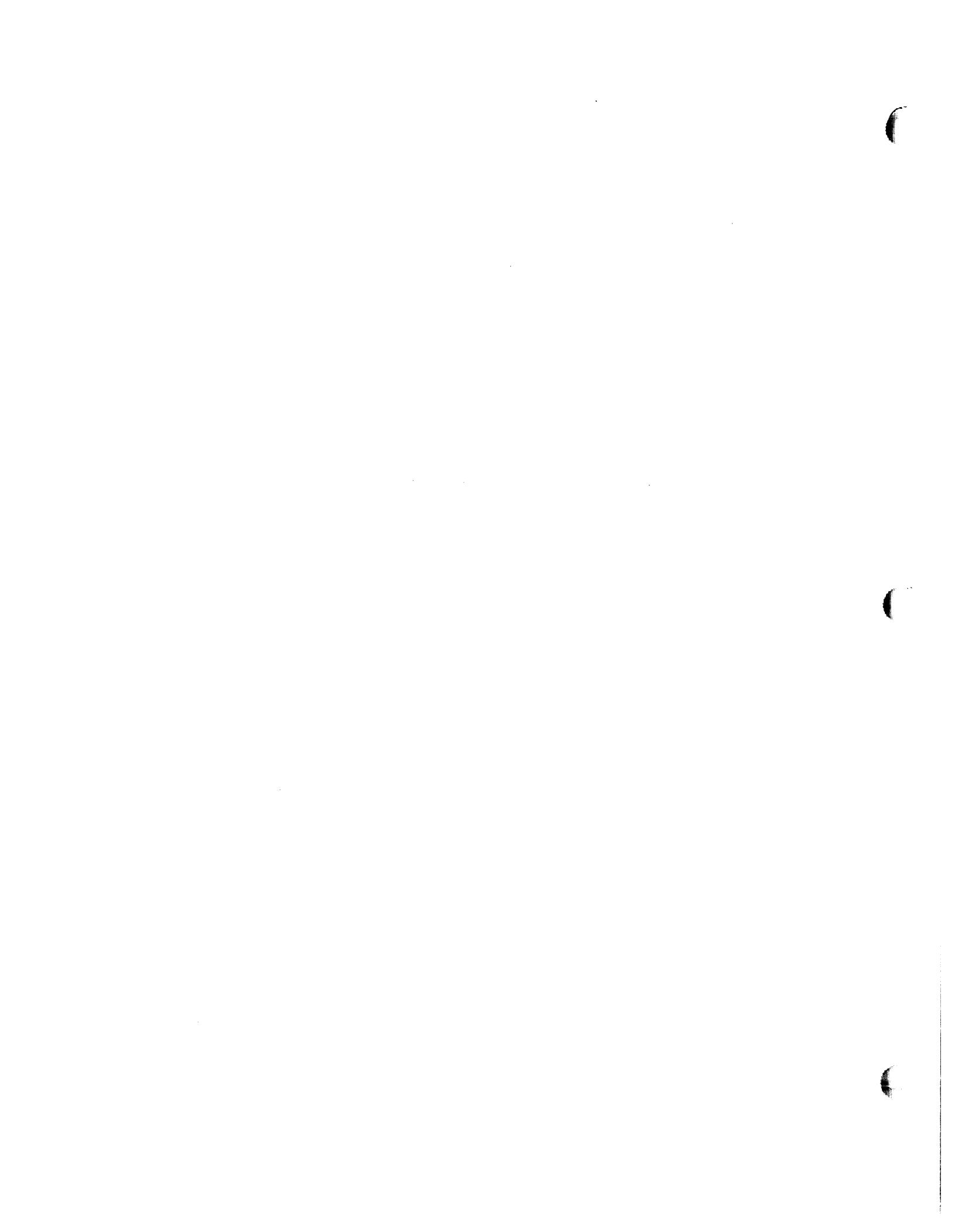

PREFACE

This manual contains sufficient information to connect and configure the drives supported by System Industries disk controllers. The manual consists of an Overview Section, several sections pertaining to current disk drives, and three appendices.

Other applicable System Industries' publications as follows:

Publication Number	Title
PB3100-9041	SI 3100 Series Disk Controller User's Guide
PB3400-9041	SI 3400 Series Disk Controller User's Guide
PB6100-9041	SI 6100 Disk Controller User's Guide
PB6200-9041	SDA50 Disk Controller User's Guide
PB9900-9041	SI 9000 Disk Controller User's Guide
PB9910-9041	SI 9910 UNIBUS™ CPA User's Guide
PB9920-9041	SI 9900 Cache Bus CPA User's Guide
PB9930-9041	SI 9900 SBI™ CPA User's Guide
PB9940-9041	SI 9900 CMI CPA User's Guide
PB9710-9041	SI 9700 UNIBUS MTA User's Guide
PB9720-9041	SI 9700 Cache Bus MTA User's Guide
PB9730-9041	SI 9700 SBI MTA User's Guide
PB9740-9041	SI 9700 CMI MTA User's Guide

Other applicable publications:

B03P-4580-0100A	Fujitsu M228X Fixed Disk Unit Customer Engineering Manual
BO3P-4655-0001A	Fujitsu M2351A/AF Mini-disk Drive Engineering Specifications
B03P-4760-0101A	Fujitsu M2331/M2333 Micro-Disk Drives OEM Manual
B03P-4740-0101A	Fujitsu M2321/M2322 Micro-Disk Drives Engineering Specifications
B03P-4580-0401A	Fujitsu M2298 Fixed Disk Unit Customer Engineering Manual
B03P-4825-0001A	Fujitsu M2361A Mini-Disk Drive Engineering Specifications
83322310	CDC Storage Module Drive BK6XX, BK7XX Hardware Maintenance Manual
83322150	CDC Storage Module Drive BK5XX Hardware Maintenance Manual
83323560	CDC Storage Module Drive BZ7XX Hardware Maintenance Manual

UNIBUS and SBI are trademarks of Digital Equipment Corporation.

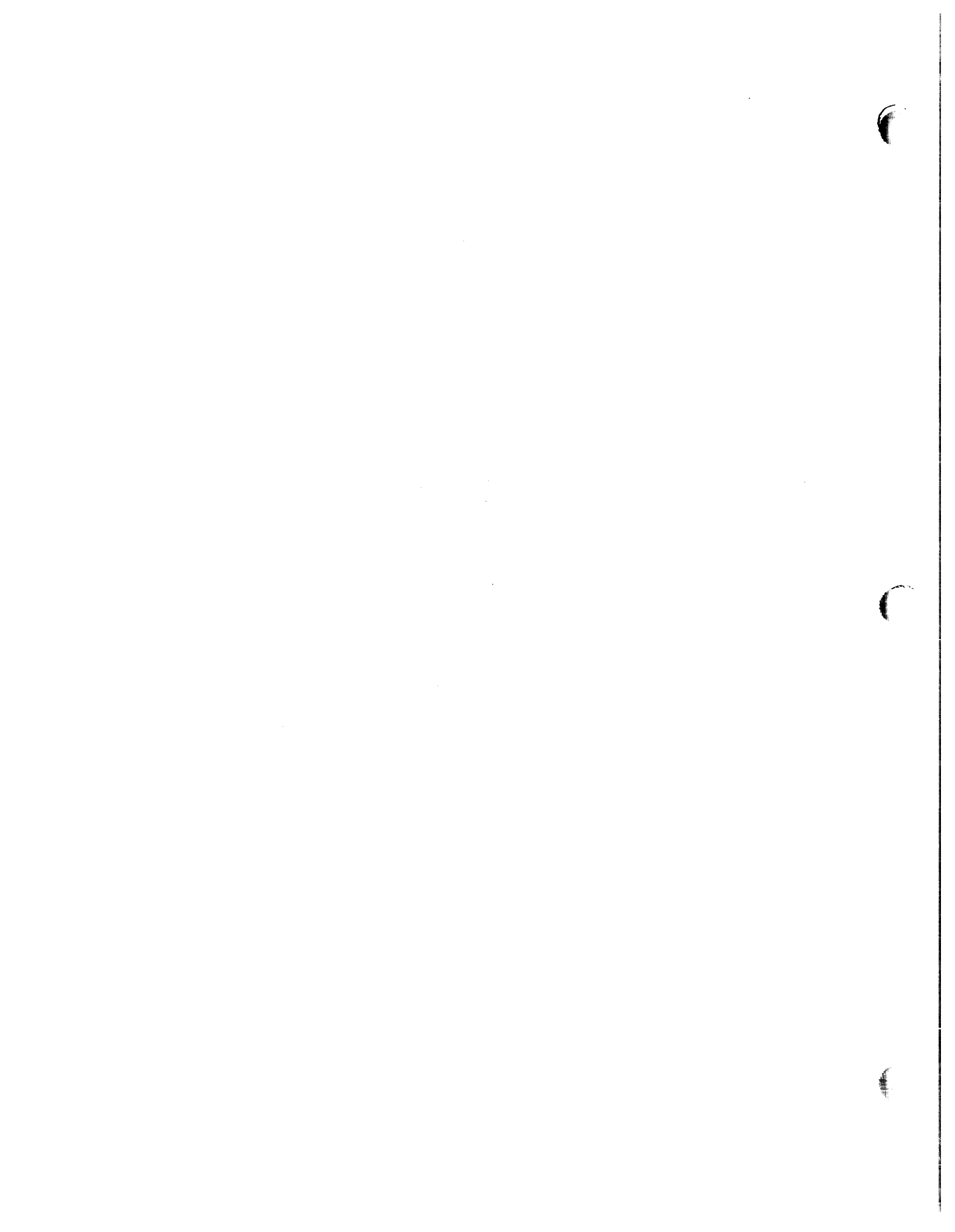

TABLE OF CONTENTS

Section	Page
1 Overview	
1.1 FCC Compliance	1-1
1.2 Cable Interface	1-2
1.2.1 Cable Transition Panel Assemblies	1-2
1.2.2 Shielded Cable I/O Bracket	1-7
1.3 Cabling	1-7
1.3.1 Radial Cabling	1-7
1.3.2 Daisy-chain Cabling	1-7
2 SI 9766 Disk Drive	
2.1 9766 Power requirements	2-1
2.2 9766 Grounding Requirements	2-1
2.3 9766 Address Selection	2-4
2.4 9766 Sector Count	2-4
2.5 9766 Drive Index and Sector Signals	2-5
2.6 9766 Radial Cabling	2-10
2.7 9766 Daisy-chain Cabling	2-13
3 SI 9775 Disk Drive	
3.1 9775 Power Requirements	3-1
3.2 9775 Grounding Requirements	3-1
3.3 9775 Address Selection	3-4
3.4 9775 Sector Count	3-5
3.5 9775 Drive with CFAX, DFAX, MFAX, WFAX, or AAFAX Card	3-5
3.6 9775 Radial Cabling	3-10
3.7 9775 Daisy-chain Cabling	3-13
4 SI 9751 Disk Drive	
4.1 9751 Power Requirements	4-1
4.2 9751 Grounding Requirements	4-3
4.3 9751 Address Selection	4-6
4.4 9751 Sector Count	4-7
4.5 9751 Drive Index and Sector Signals	4-9
4.6 9751 Cabling	4-9
4.6.1 9751 Radial Cabling	4-10
4.7 9751 Daisy-chain Cabling	4-10
5 SI 9722 Disk Drive	
5.1 9722 Power Requirements	5-1
5.1.1 9722 Power Supply Unit	5-1
5.1.2 AC Voltage Selection	5-2
5.1.3 9722 Power/Device Alarm Indicators	5-3
5.2 9722 Grounding Requirements	5-4
5.3 9722 Address Selection	5-7
5.4 9722 Sector Count	5-7
5.5 9722 Drive Index and Sector Signals	5-8

TABLE OF CONTENTS (Continued)

Section	Page
5.6 9722 Radial Cabling	5-8
5.7 9722 Daisy-chain Cabling	5-11
6 SI 9733 Disk Drive	
6.1 9733 Power and Grounding	6-1
6.1.1 9733 Power Requirements	6-1
6.1.2 9722 Power Supply Unit	6-1
6.1.3 9733 Grounding Specifications	6-4
6.2 9733 Address Selection	6-7
6.3 9733 Sector Count	6-8
6.4 9733 Drive Index and Sector Signals	6-8
6.5 9733 Radial Cabling	6-8
6.6 9733 Daisy-chain Cabling	6-11
7 SI 9798 Disk Drive	
7.1 9798 Power Requirements	7-1
7.2 9798 Grounding Requirements	7-5
7.3 9798 Address Selection	7-6
7.4 9798 Sector Count	7-7
7.5 9798 Drive Index and Sector Signals	7-8
7.6 9798 Radial Cabling	7-8
7.7 9798 Daisy-chain Cabling	7-9
8 SI 9761 Disk Drive	
8.1 9761 Power Requirements	8-1
8.1.1 AC Voltage Selection	8-2
8.2 9761 Grounding Requirements	8-3
8.3 9761 Address Selection	8-6
8.4 9761 Sector Count	8-7
8.5 9761 Drive Index and Sector Signals	8-8
8.6 9761 Radial Cabling	8-8
8.7 Daisy-chain Cabling	8-9
9 SI 9762 Disk Drive	
9.1 9762 Power Requirements	9-1
9.2 9762 Grounding Requirements	9-1
9.3 9762 Address Selection	9-4
9.4 9762 Sector Count	9-4
9.5 9762 Drive Index and Sector Signals	9-5
9.6 9762 Radial Cabling	9-8
9.7 9762 Daisy-chain Cabling	9-11
10 SI 9784 Disk Drive	
10.1 9784 Power Requirements	10-1
10.2 9784 Grounding Requirements	10-4
10.3 9784 Address Selection	10-5
10.4 9784 Sector Count	10-6
10.5 9784 Drive Index and Sector Signals	10-8

TABLE OF CONTENTS (Continued)

Section	Page
10.6 9784 Radial Cabling	10-8
10.7 9784 Daisy-chain Cabling	10-11
Appendix	
A Daisy-chain Adapter	
A.1 Configurations	A-1
A.2 Physical Description	A-1
A.3 Controller Interface	A-1
A.4 Disk Drive Interface	A-1
A.5 Functional Description	A-1
A.6 Installation	A-5
A.6.1 Visual Inspection	A-5
A.6.2 Daisy-chain Adapter Cabling	A-5
A.6.3 Drive Cabling	A-6
A.6.4 Adapter Cabling in Single-Channel Configuration	A-7
B Dual Channel Adapter for 9784 Drive	
B.1 Installing the Dual-Channel Adapter	B-2
B.2 Operation Switches and LEDs	B-3
C SI 9722/9733 Dual Port Option	
C.1 Installation	C-1
C.1.1 Assembling and Mounting the Dual Port Option	C-1
C.1.2 Cabling the Dual Port Option PCB	C-3
C.1.3 Dual Channel Option Controls and Indicators	C-4
C.2 SI 9722 Front Panel Controls and Indicators	C-5
D Quick Disconnect System	
D.1 Physical Description	D-1
D.2 Cabling	D-5
D.3 Drive Modifications	D-5
D.4 9722/33 Quick Disconnect Installation	D-5
D.5 Insertion and Removal of the Modified 9722/9733	D-6
D.6 Dual Channel Option Installation	D-7

LIST OF FIGURES

Figure	Page
1-1 Cable Distribution Assembly (9901-606X)	1-3
1-2 9901-6061 Connector Layout	1-5
1-3 9901-6062 Connector Layout	1-5
1-4 9901-6064 Connector Layout	1-6
1-5 9901-6065 Connector Layout	1-6
2-1 9766 Floor Grid System Grounding	2-2
2-2 9766 Daisy-chain System Grounding	2-2
2-3 9766 Grounding Block	2-3
2-4 9766 Sector Count Switch Location	2-4
2-5 ___TVV Card Jumpered for A-Cable Gated	2-6

LIST OF FIGURES (Continued)

Figure		Page
2-6	__TVV Card Jumpered for A- or B-Cable Continuous	2-7
2-7	9766 B-Cable Index and Sector Plugs	2-8
2-8	9766 Shielded Cable I/O Bracket	2-10
2-9	9766 Shielded Cable I/O Bracket Location	2-11
2-10	9766 Radial Cabling	2-12
2-11	9766 Daisy-chain Cabling	2-14
3-1	9775 Floor Grid System Grounding	3-2
3-2	9775 Daisy-chain System Grounding	3-2
3-3	9775 Grounding Block	3-3
3-4	9775 __LEX Board	3-4
3-5	__FAX Card Jumpered for A-Cable Gated	3-6
3-6	__FAX Card Jumpered for A-Cable Continuous	3-6
3-7	__FAX Card Jumpered for B-Cable Continuous	3-7
3-8	MFAX, WFAX, or AAFAX Card Jumpered for A-Cable Gated	3-8
3-9	MFAX, WFAX, or AAFAX Card Jumpered for B-Cable Continuous	3-9
3-10	9775 Shielded Cable I/O Bracket	3-10
3-11	9775 Shielded Cable I/O Bracket Location	3-11
3-12	9775 Radial Cabling	3-12
3-13	9775 Daisy-chain Cabling	3-13
4-1	9751 Power Supply Unit Control Panel	4-2
4-2	9751 Grounding Method 1	4-4
4-3	9751 Grounding Method 2	4-4
4-4	9751 Grounding Method 3	4-5
4-5	9751 Grounding Scheme for Shipping	4-5
4-6	9751 Interface PCB (DQEMU)	4-6
4-7	9751 Logic PCB	4-8
4-8	9751 Sector Jumper States	4-8
4-9	9751 Jumper Settings for 48 Sectors	4-9
4-10	9751 Interface Board (DQEMU), Daisy-chain, Single Channel	4-11
5-1	9722 Power Supply Control Panel	5-2
5-2	9722 Signal Ground to Frame Ground Jumper Strap	5-4
5-3	9722 Grounding Method 1	5-5
5-4	9722 Grounding Method 2	5-5
5-5	9722 Grounding Method 3	5-6
5-6	9722 Grounding Scheme for Shipping	5-6
5-7	9722 Address and Sector Count Switch Locations on CZFM	5-7
5-8	9722 Block Diagram, Radial Cabling, Single Channel	5-9
5-9	9722 Block Diagram, Radial Cabling, Dual Channel	5-9
5-10	9722 Dual Channel Interface PCB	5-10
5-11	9722 Block Diagram, Daisy-chain Cabling, Single Channel	5-11
5-12	9722 Block Diagram, Daisy-chain, Dual Channel	5-12
6-1	9733 AC Voltage Selection Switch and Retainer Plate	6-2
6-2	9733 Signal Ground to Frame Ground Jumper	6-4
6-3	9733 Grounding Method 1	6-5
6-4	9733 Grounding Method 2	6-5
6-5	9733 Grounding Method 3	6-6
6-6	9733 Grounding Scheme for Shipping	6-6
6-7	9733 Interface PCB (KGFM)	6-7
6-8	9733 Radial Cabling, Single Channel	6-9
6-9	9733 Radial Cabling, Dual Channel	6-9

LIST OF FIGURES (Continued)

Figure		Page
6-10	9733 Dual Channel Interface PCB	6-10
6-11	9733 Block Diagram, Daisy-chain Cabling, Single Channel	6-12
6-12	9733 Block Diagram, Daisy-chain Cabling, Dual Channel	6-12
7-1	9798 AC Voltage Selection	7-3
7-2	9798 + 24/ - 32 VDC Select Switch	7-3
7-3	Power Cable Connection for 9798 (50 Hz)	7-4
7-4	Power Cable Connection for 9798 (60 Hz)	7-4
7-5	9798 Drive Ground Terminal	7-5
7-6	9798 Auxiliary Ground Cable	7-6
7-7	9798 Address Switch Location on KGEM PCB	7-6
7-8	9798 Sector Count Switch Location on VOIM PCB	7-7
7-9	9798 Radial Cabling, Single Channel	7-9
7-10	Daisy-chain Cabling, Single Channel	7-10
8-1	9761 Power Supply Control Panel	8-2
8-2	9761 Grounding Method 1	8-4
8-3	9761 Grounding Method 2	8-4
8-4	9761 Grounding Method 3	8-5
8-5	9761 Grounding Scheme for Shipping	8-5
8-6	9761 Front Panel	8-6
8-7	9761 Switch Locations	8-7
8-8	9761 Radial Cabling, Single Channel	8-8
8-9	9761 Radial Cabling, Dual Channel	8-9
8-10	9761 Daisy-chain Cabling, Single Channel	8-10
8-11	9761 Daisy-chain Cabling, Dual Channel	8-10
9-1	9762 Floor Grid System Grounding	9-2
9-2	9762 Daisy-chain System Grounding	9-3
9-3	9762 Grounding Lug	9-3
9-4	9762 Sector Count Switch Location	9-4
9-5	__TVV Card Jumpered for A-Cable Gated	9-6
9-6	__TVV Card Jumpered for A- or B-Cable Continuous	9-6
9-7	9762 Backplane Slot B07 Grounding Plug	9-7
9-8	9762 Shielded Cable I/O Bracket	9-8
9-9	9762 Radial Cabling	9-10
9-10	9762 Daisy-chain Cabling	9-11
10-1	9784 AC Voltage Selection, 50/60 Hz	10-2
10-2	9784 + 24 or - 32 VDC Select Switch	10-3
10-3	Power Cable Connection for 9784, 50 Hz	10-3
10-4	Power Cable Connection for 9784, 60 Hz	10-3
10-5	9784 Drive Ground Terminal	10-4
10-6	9784 Auxiliary Ground Cable	10-5
10-7	9784 Address Switch Location on CQFM PCB	10-5
10-8	9784 Sector Count Switch Locations on VOFM PCB	10-7
10-9	9784 Radial Cabling, Single Channel	10-9
10-10	9784 Radial Cabling, Dual Channel	10-10
10-11	9784 Daisy-chain Cabling, Single Channel	10-12
10-12	9784 Daisy-chain Cabling, Dual Channel	10-13
10-13	9784 Daisy-chain Cabling, Dual Channel, (Side Detail)	10-14
A-1	Daisy-chain Adapter Housing	A-2
A-2	Daisy-chain Housing (Interior View)	A-3
A-3	Daisy-chain Adapter Interconnect Diagram	A-4
B-1	Dual Channel Adapter	B-1

LIST OF FIGURES (Continued)

Figure		Page
B-2	Location of Dual Channel Adapter Switches and LEDs	B-3
C-1	Dual Option PCB Installation	C-2
C-2	Power Supply Control Panel	C-3
C-3	Dual Channel PCB Layout	C-4
D-1	Quick Disconnect (Rear View)	D-2
D-2	Quick Disconnect (Interior View)	D-3
D-3	Modified 9722/9733 Drive	D-4
D-4	Dual Channel Option Installation	D-9

LIST OF TABLES

Table		Page
1-1	Supported SI Disk Drives	1-1
1-2	PCB Assembly Configurations	1-4
2-1	9766 Voltage Requirements	2-1
2-2	9766 Maximum Current Requirements	2-1
2-3	9766 Sector Count Switch Settings	2-5
3-1	9775 Voltage Requirements	3-1
3-2	9775 Maximum Current Requirements	3-1
3-3	9775 Address Selection Switch Settings	3-4
3-4	9775 Sector Count Switch Settings	3-5
4-1	9751 Voltage Requirements	4-1
4-2	9751 Maximum Current Requirements	4-1
4-3	9751 Voltage Selection Wire-to-Tap Configuration	4-3
4-4	9751 Address Selection Switch Settings	4-6
4-5	9751 Sector Selection Jumper Settings	4-7
5-1	9722 AC Voltage Specifications	5-3
5-2	9722 DC Voltage Specifications	5-3
5-3	9722 Maximum Current Requirements	5-3
5-4	9722 Address Selection Switch Settings	5-7
5-5	9722 Sector Count Switch Settings	5-8
6-1	9733 AC Voltage Specifications	6-3
6-2	9733 DC Voltage Specifications	6-3
6-3	9733 Maximum Current Requirements	6-3
6-4	9733 Address Selection Switch Settings	6-7
6-5	9733 Sector Count Settings	6-8
7-1	9798 Voltage Requirements	7-1
7-2	9798 AC Power Requirements	7-1
7-3	9798 DC Voltage/Current Requirements	7-2
7-4	9798 Address Selection Switch Settings	7-7
7-5	9798 Sector Count Switch Settings	7-8
8-1	9761 Voltage Requirements	8-1
8-2	9761 Maximum Current Requirements	8-1
8-3	9761 Address Selection Switch Settings	8-6
8-4	9761 Sector Count Switch Settings	8-7
9-1	9762 Voltage Requirements	9-1
9-2	9762 Maximum Current Requirements	9-1
9-3	9762 Sector Count Switch Settings	9-5
10-1	9784 Voltage Requirements	10-1
10-2	9784 Maximum Current Requirements	10-1
10-3	9784 Address Selection Switch Settings	10-6
10-4	9784 Sector Count Switch Settings	10-8
C-1	Dual Option PCB Switch Settings and Functions	C-5

SECTION 1 OVERVIEW

Currently supported SI disk drives are listed in Table 1-1.

Table 1-1. Supported SI Disk Drives

SI DRIVE MODEL	UNFORMATTED STORAGE CAPACITY (MBYTES)	TYPE
9766	300	RMD*
9775	675	FMD**
9751	474	FMD
9722	168	FMD
9733	337	FMD
9798	671	FMD
9761	689	FMD
9762	80	RMD
9784	160	FMD

*RMD = Removable Media Drive

**FMD = Fixed Media Drive

The following SI drives are rackmountable: SI 9798, 9761, 9784, 9751, 9733, 9722

The remaining sections of this manual are devoted to each supported drive and provide information about the following:

- Power requirements
- Grounding
- Address selection
- Sector count
- Index/sector signal options
- Cabling

1.1 FCC Compliance

To comply with Federal Communications Commission regulations covering class A computing devices (Part 15, Subpart J), it is necessary to reduce electromagnetic interference (EMI) to acceptable levels. The most common form of EMI in electronic computing systems is radio frequency interference (RFI), because computer systems use RF energy for timing and control functions and generate RFI.

RFI can be propagated in two ways: radiation and conduction. Radiated RFI travels through space; conducted RFI travels along power cords. These two kinds of RFI are controlled by shielding and filtering respectively.

Shielding prevents radiation of interference by containing electrical noise within the confines of a shielded structure, such as a cabinet or a cable assembly. In the case of cabinets, shielding techniques include metal to metal bonding, the elimination of large slots, and the use of substantial grounding conductors between the panels and the frame.

Cables which exit from a shielded enclosure must be shielded or filtered. Shielding is a technique that creates an extension of the cabinet environment to cover the entire cable, whereas filtering is a technique that prevents electrical interference from being conducted along a cable.

Generally, shielding is used on all signal handling cables and filtering is used on all power cables.

1.2 Cable Interface

There are two methods of interfacing external cables to compliant cabinets: a transition panel for an SI compliant cabinet and shielded cable I/O brackets in other compliant cabinets.

Installations in noncompliant cabinets require a transition panel or adapter bracket that can be mounted on a standard 19-inch EIA equipment rack.

NOTE

Shielded cable interface devices are referred to by a variety of terms: I/O distribution panel, IOCP (a DECTM mnemonic for input/output connector panel), transition panel, cable distribution panel, cable distribution assembly, transition modules, or I/O adapter brackets, e.g., they also exist in various configurations, but their basic function is the same: to provide a means to terminate shielded I/O cables.

1.2.1 Cable Transition Panel Assemblies

The configuration of a cable transition panel assembly is a function of the type of cabinet and the number and kinds of devices in the cabinet. Currently there are three types of cabinets for housing drives and controllers:

- 42-inch (107 cm) lowboy
- 60-inch (152 cm) highboy
- 28-inch (71 cm) tower

The tower cabinet is used in some DEC microcomputer installations.

Some panel assemblies may have feedthrough bulkhead or crossover connectors that were factory installed, while others may have ports with blanking plates that can be removed as required. Generally, the ports are 60-sized and 40-sized. There are adapter plates that allow these ports to accommodate 26-conductor cables.

Cabinets housing controllers and drives interfacing with HP CPUs have a specially designed transition panel to accommodate HPIBTM (Hewlett-Packard Interface Bus) cables.

An exception to the panel assemblies mentioned above is the SI Cable Distribution Assembly 9901-606X.

DEC is a trademark of Digital Equipment Corporation.
HPIB is a trademark of Hewlett-Packard Company.

1.2.1.1 Cable Distribution Assembly 9901-606X

This assembly is no longer factory installed in SI FCC-compliant disk storage subsystems. However, it can still be found in some installations, and a modified version of it will continue to be used in installations involving certain kinds of noncompliant CPU or expansion cabinets.

The assembly consists of three basic components (Figure 1-1).

- A transition panel
- A tray-mounted PCB assembly containing 60-, 40- and 26-pin male headers arranged in a four by eight array that can interface a maximum of 16 devices.
- A hinge on the lower edge of the panel allowing the complete assembly to be rotated 90 degrees to permit better access to the connectors on the PCB.

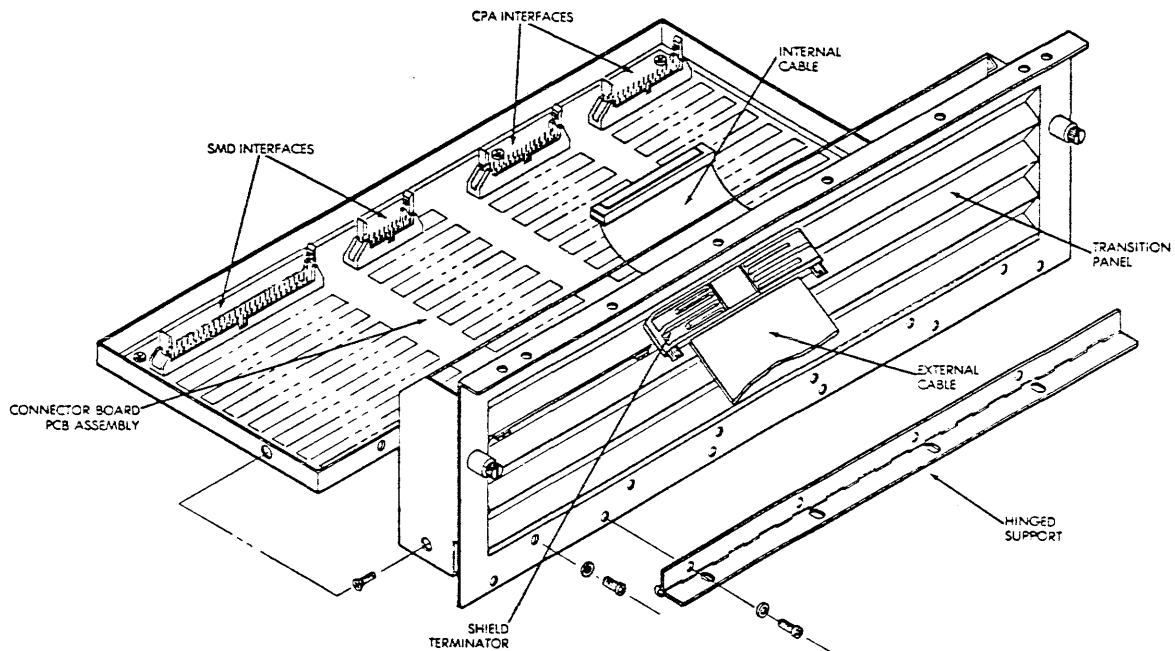

Figure 1-1. Cable Distribution Assembly (9901-606X)

There are four PCB assembly configurations. They are listed in Table 1-2 and illustrated in Figures 1-2 through 1-5. The connector columns are labeled from left to right, as viewed from the front of the assembly, J4B, J8B, J12B, and J16B (columns 1, 2, 3, and 4). The connectors are arranged and labeled as follows:

J4B	J8B	J12B	J16B
J3B	J7B	J11B	J15B
J2B	J6B	J10B	J14B
J1B	J5B	J9B	J13B
J1A	J5A	J9A	J13A
J2A	J6A	J10A	J14A
J3A	J7A	J11A	J15A
J4A	J8A	J12A	J16A

B connectors are mated to internal cables and A connectors to shielded external cables via the transition panel. This labeling is constant regardless of the PCB assembly configuration.

The connectors in each column are hard wired in pairs, e.g., J4B to J4A, J3B to J3A, J8B to J8A, etc.

Table 1-2. PCB Assembly Configurations

PART NUMBER	CONNECTORS		QUANTITY	NUMBER OF OUTGOING CABLES
	COLUMN	TYPE		
9901-6061	all	40-pin	32	16
9901-6062	1	60-pin	8	4
	2	26-pin	8	4
	3, 4	40-pin	16	8
9901-6064	1, 2	60-pin	16	8
	3, 4	26-pin	16	8
9901-6065	1	60-pin	8	4
	2*	60-pin	4	2
	2*	26-pin	4	2
	3	26-pin	8	4
	4	40-pin	8	4

*This configuration has a mixture of 60- and 26-pin connectors in column 2.

For further information refer to the SI FCC-compliant Cabinet User's Guides, PB9950-9041 and PB9951-9041.

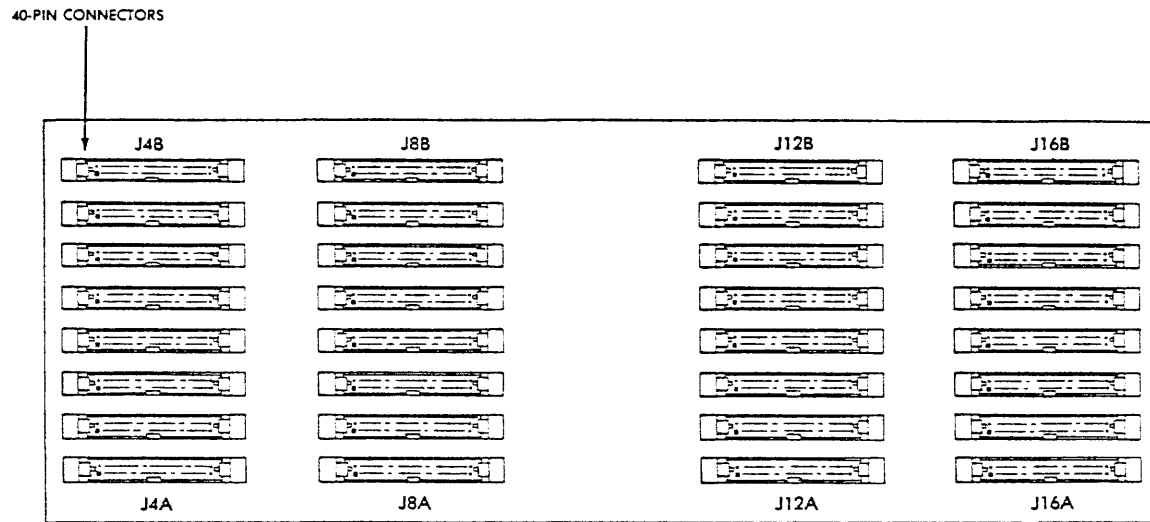

Figure 1-2. 9901-6061 Connector Layout

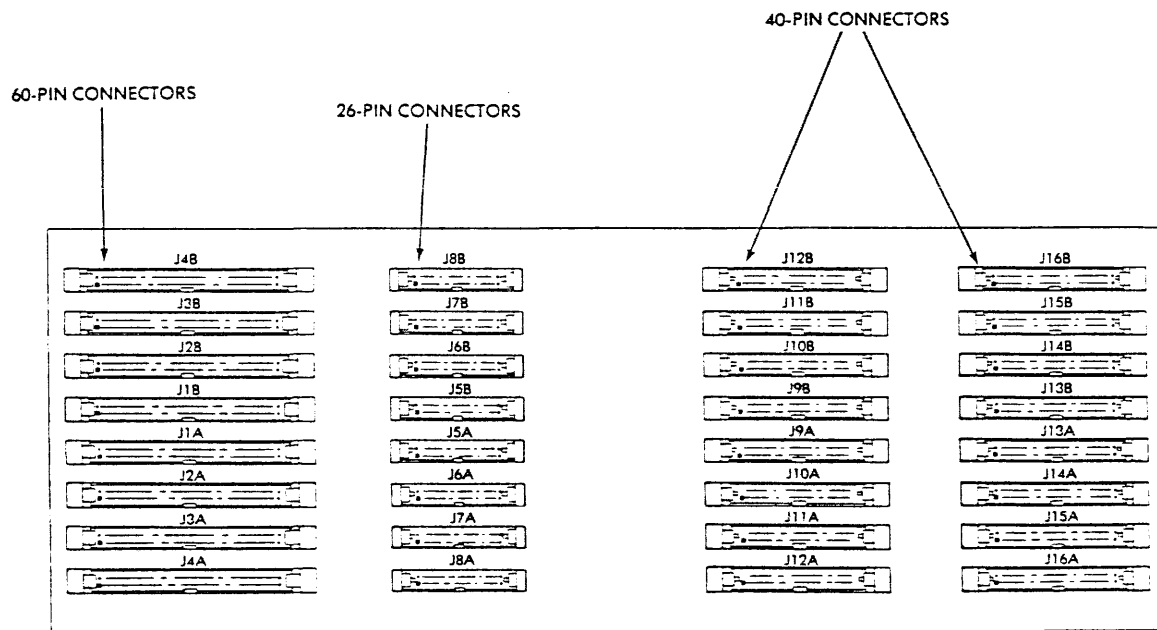

Figure 1-3. 9901-6062 Connector Layout

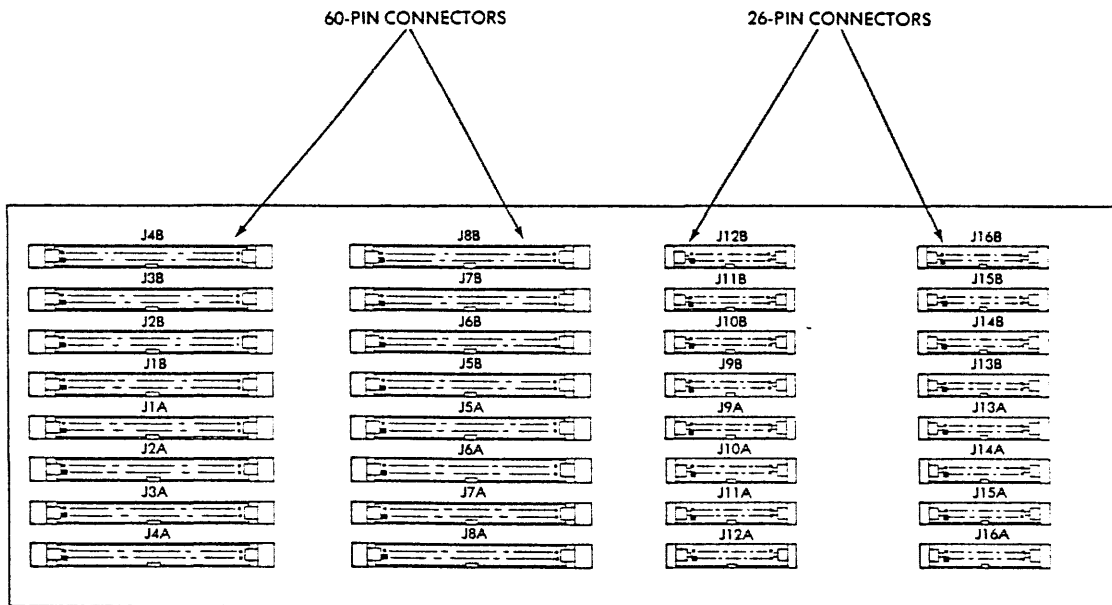

Figure 1-4. 9901-6064 Connector Layout

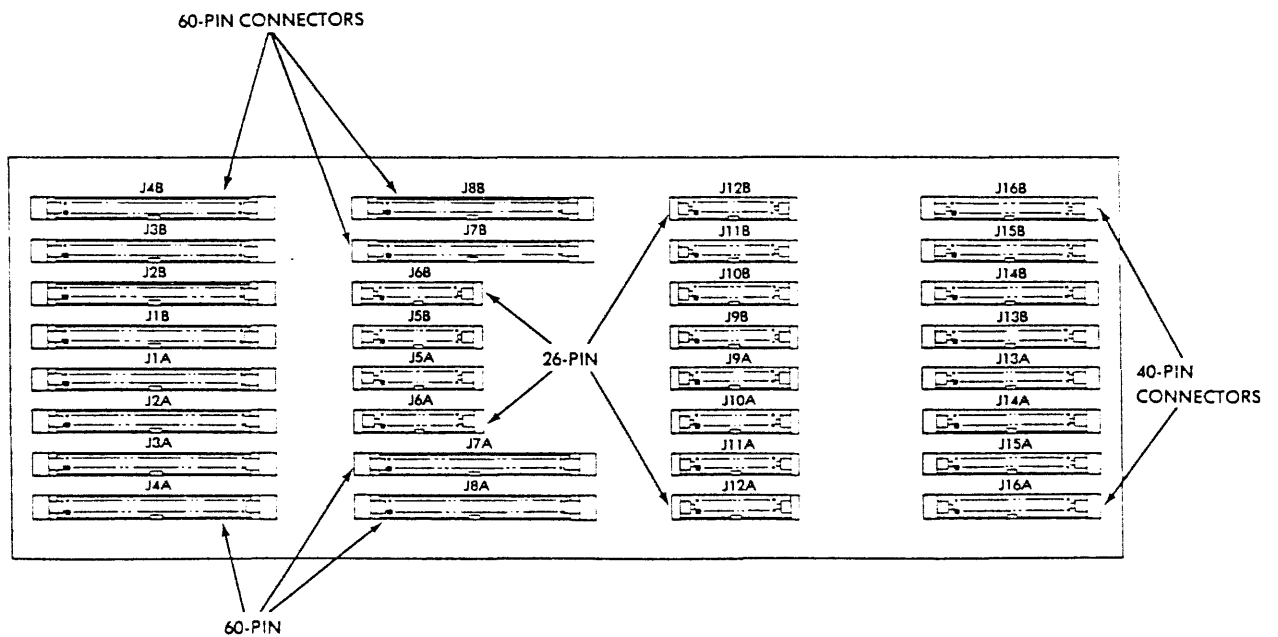

Figure 1-5. 9901-6065 Connector Layout

1.2.2 Shielded Cable I/O Bracket

When SI 9762, 9766, or 9775 drives, which are standalone units mounted in pedestal cabinets, are part of the storage subsystem, I/O adapter brackets serve as the shielded cable interfaces. These are illustrated in those sections pertaining to the above drives.

1.3 Cabling

The procedures in this manual describe both internal and external cabling, even though internal drive/controller cabling is usually done at the factory.

1.3.1 Radial Cabling

Each radially connected disk drive communicates with the controller via discrete A- and B-cables. Currently, only 99XX controllers support radial cabling.

1.3.2 Daisy-chain Cabling

In a daisy-chain configuration all drives communicate with the controller via a common A-cable and discrete B-cables.

The A-cable connects the disk interface board to the first drive in the chain. Each additional drive is connected by an A-cable to the drive preceding it. The last drive in the chain is then terminated.

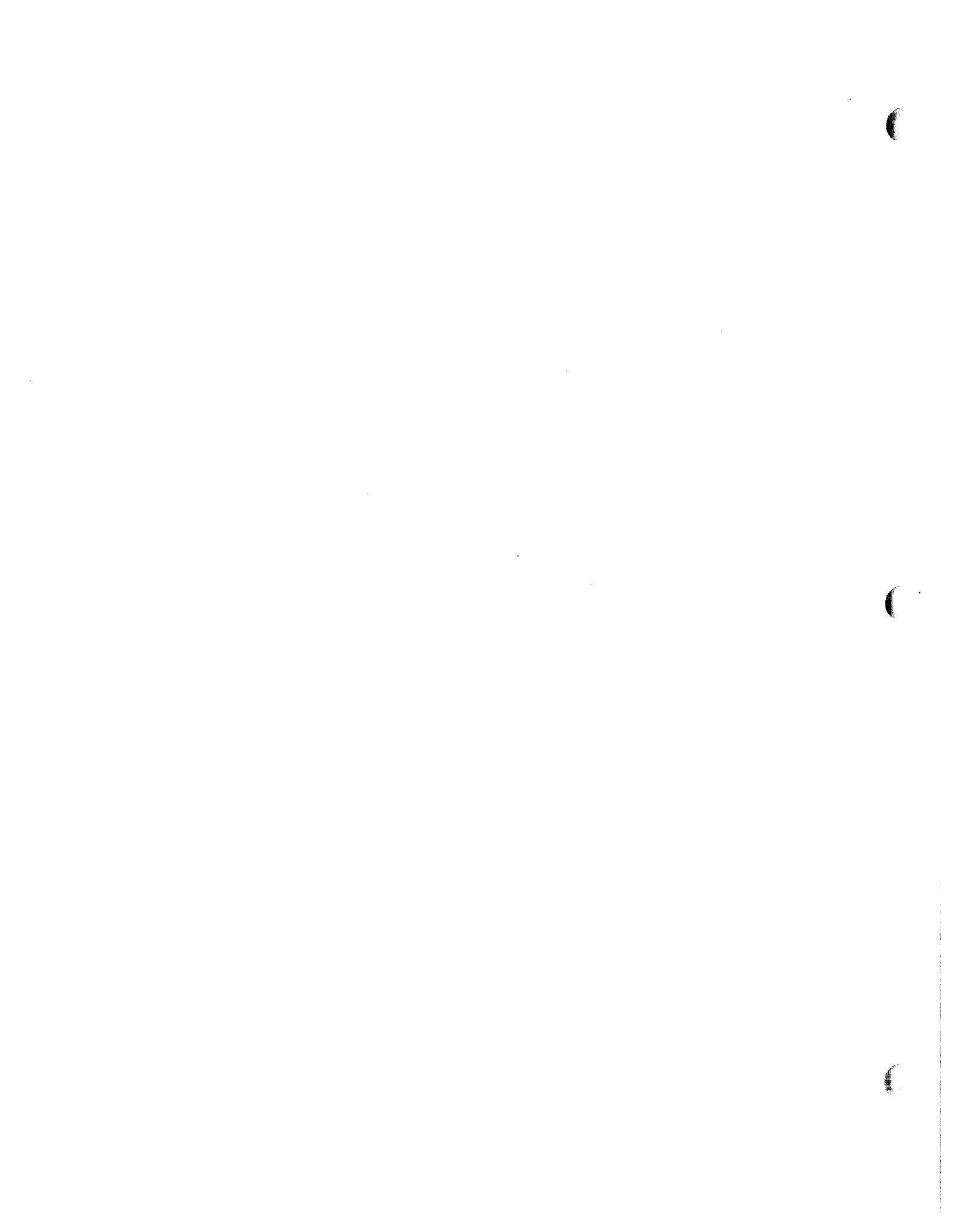

SECTION 2 SI 9766 DISK DRIVE

The SI 9766 is a 300 Mbyte RMD mounted in an FCC-compliant pedestal cabinet.

2.1 9766 Power Requirements

The site must have an AC power source for each drive. Each drive connects to the power source through a 6-foot cord provided with the drive.

Sixty-Hertz drives are supplied with a 3-pin, 20-amp, 240-volt locking power connector (NEMA configuration L6-20P). The mating receptacle must be NEMA configuration L6-20R (e.g., Hubbell 2320, 2323, or 2326; Bryant 70620, or Arrow 6210.)

Fifty-Hertz drives are not supplied with a power connector.

The voltage requirements and maximum current requirements are listed in Tables 2-1 and 2-2.

Table 2-1. 9766 Voltage Requirements

VAC	RANGE (VAC)	FREQUENCY (HZ)	RANGE (HZ)
208	179—222.6	60	59.0—60.6
230	198—244.5	60	59.0—60.6
220	195—235	50	49.0—50.5
240	213—257	50	49.0—50.5

Table 2-2. SI 9766 Maximum Current Requirements

VAC/HZ	CURRENT IN AMPS	
	OPERATING*	STANDBY**
208/60	8.0	2.0
230/60	7.2	1.8
220/50	9.5	2.5
240/50	8.7	2.3

*Carriage and disks in motion

**Disks not rotating

2.2 9766 Grounding Requirements

The site AC power source must provide two types of grounding: safety ground and system ground.

A safety ground is provided by an insulated green (or green with yellow stripe) grounding conductor in the AC power cord. This wire is connected to the drive frame and is grounded to earth through the AC circuit supplying power to the drive.

Adequate system grounding provides additional connections to earth ground. System grounding reduces radio frequency interference (RFI) radiation, and can be provided by any of the following methods (listed in preferred order):

Grounded Floor Grid The drives and the controller are connected to a grounded floor grid to ensure a constant ground potential at all connection points. The grid is connected directly to earth ground (Figure 2-1).

Ungrounded Floor Grid The drives and the controller are connected to an ungrounded floor grid. The controller is connected to earth ground which grounds the grid and the drives (Figure 2-1).

Daisy Chain The drive ground terminals are daisy-chained from drive to drive and then to the controller. The controller is connected to earth ground (Figure 2-2).

The system ground must provide earth ground connection for both AC (frame) ground and DC (logic) ground. Drives are shipped with the AC and DC grounds jumpered together at the grounding block. Only one system ground connection is required. If the installation requires AC and DC grounds to be isolated, the jumper must be removed and both grounds connected to earth ground by separate system ground connections. Figure 2-3 illustrates the grounding block, the jumper, and the placement of the groundstrap.

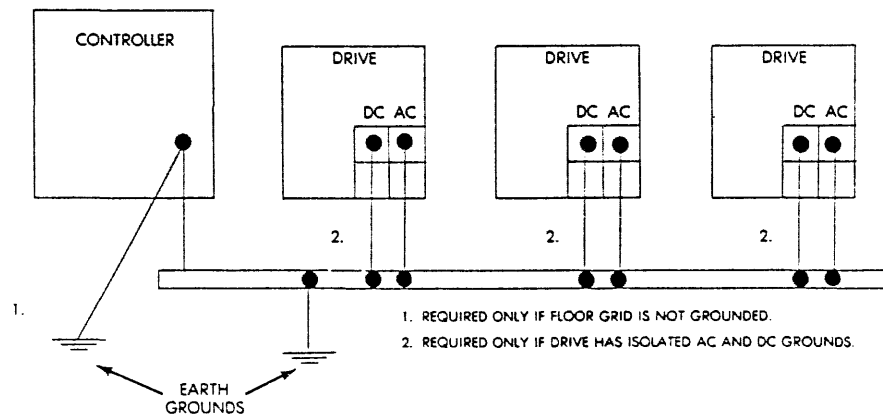

Figure 2-1. 9766 Floor Grid System Grounding

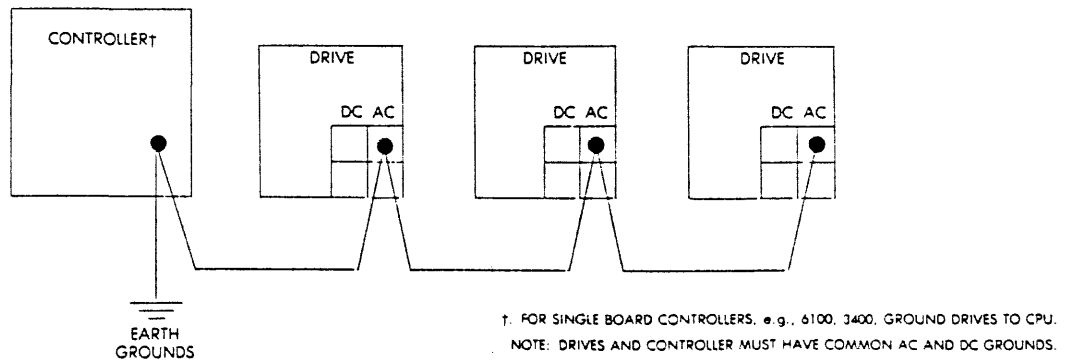

Figure 2-2. 9766 Daisy-chain System Grounding

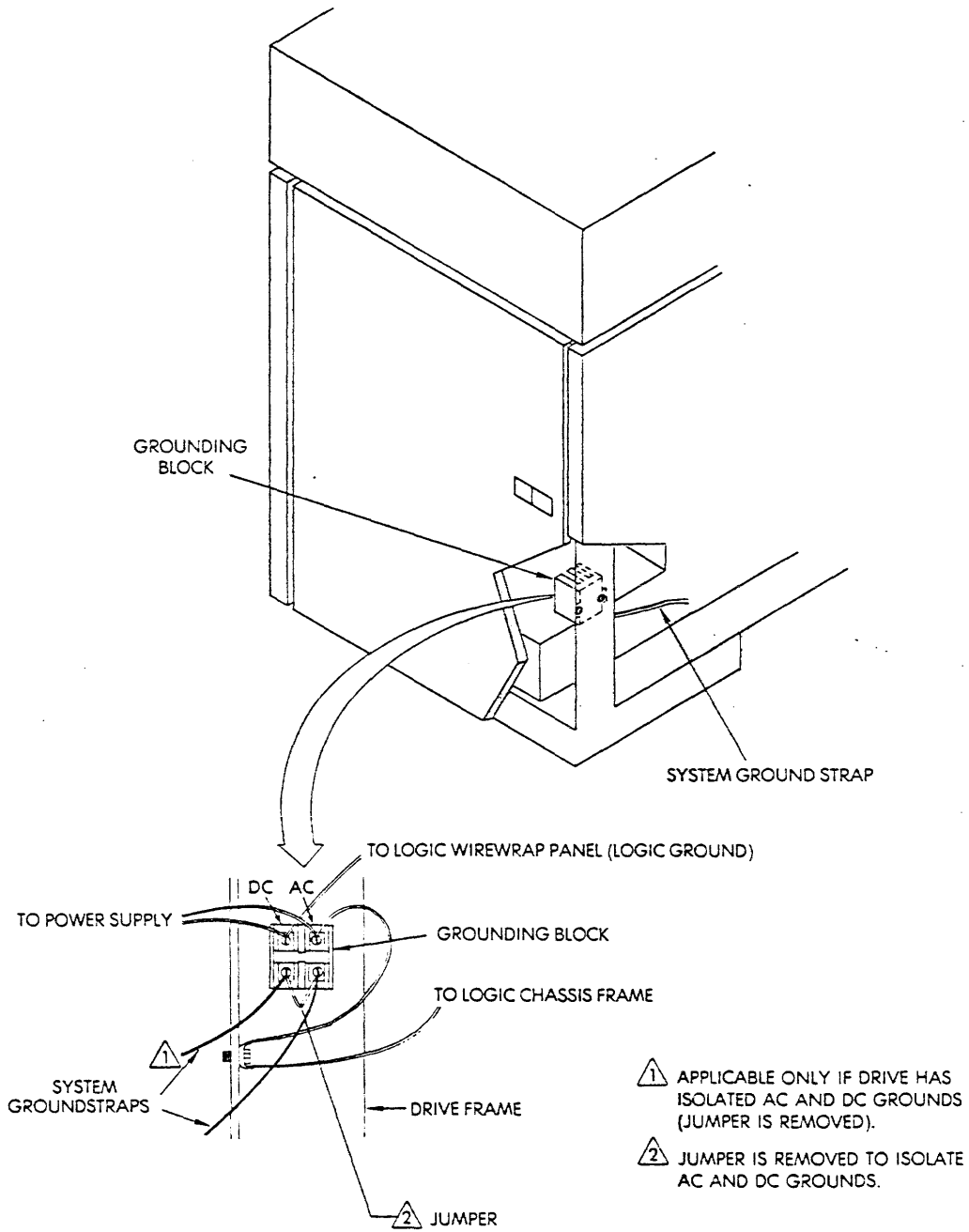

Figure 2-3. SI 9766 Grounding Block

2.3 9766 Address Selection

This drive is assigned an address by installing a drive identifier plug in the drive front panel.

2.4 9766 Sector Count

The sector switches are located on a card in the drive logic chassis. The card is the __LTV located in slot A06. Figure 2-4 illustrates the switch location. The switch settings for specific sector counts are listed in Table 2-3.

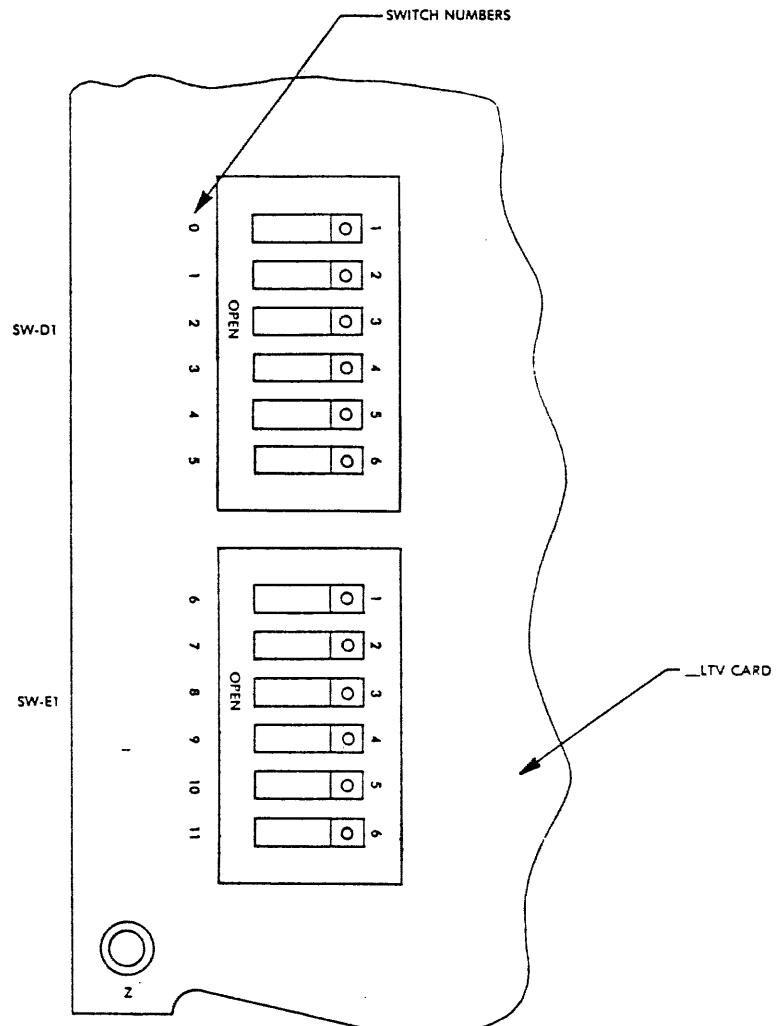

Figure 2-4. 9766 Sector Count Switch Location

Table 2-3. SI 9766 Sector Count Switch Settings

24 SECTORS		32 SECTORS		33 SECTORS		35 SECTORS		30 SECTORS*	
SWITCH#	SETTING	SWITCH#	SETTING	SWITCH#	SETTING	SWITCH#	SETTING	SWITCH#	SETTING
0	ON	0	ON	0	OFF	0	ON	0	ON
1	ON	1	ON	1	ON	1	ON	1	ON
2	ON	2	OFF	2	ON	2	ON	2	ON
3	ON	3	OFF	3	OFF	3	ON	3	ON
4	OFF	4	OFF	4	ON	4	ON	4	ON
5	ON	5	ON	5	OFF	5	ON	5	ON
6	OFF	6	OFF	6	OFF	6	OFF	6	OFF
7	OFF	7	ON	7	ON	7	ON	7	ON
8	OFF	8	ON	8	ON	8	OFF	8	ON
9	ON	9	OFF	9	OFF	9	OFF	9	OFF
10	OFF	10	OFF	10	OFF	10	OFF	10	OFF
11	OFF	11	OFF	11	OFF	11	OFF	11	OFF

*SDA and QDA controllers only.
 ON=Closed
 OFF=Open

2.5 9766 Drive Index and Sector Signals

Unless otherwise specified, this drive is supplied by System Industries with the A-cable gated option installed.

A jumper on the __TVV card (slot A01) changes the A-cable index and sector signals from gated to continuous.

Index and sector signals on older drives can be converted to B-cable continuous only by changing the position of signal wires in the I/O connectors. This physically moves the index and sector signal from the A-cable to the B-cable.

Newer drives have additional B-cable index and sector transmitters that are not gated with unit-selected signals within the drive, and are independent of the __TVV card jumper. These signals are made available by plugging a connector onto the drive logic card backplane.

NOTE

The position of the jumper on the __TVV card does NOT affect the B-cable signals on the newer drives. However, it should be in the gated position if B-cable index and sector signals are to be used.

Drive index/sector signal routing and gating options are as follows:

A-cable gated The jumper on the __TVV card (slot A01) must be in the gated position. The card should be identified as FTVV. Dual channel drives have a second card in slot A03 which must be similarly jumpered and identified (Figure 2-5).

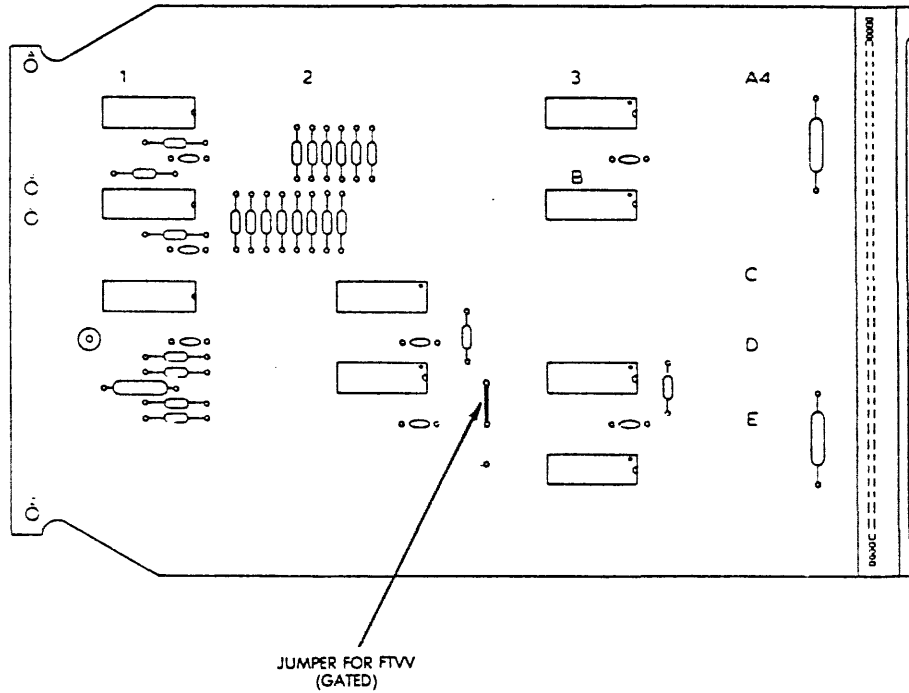

Figure 2-5. __TVV Card Jumpered for A-Cable Gated

A-cable continuous The jumper on the __TVV card (slot A01) must be in the continuous position. The card should be identified as GTVV. Dual channel drives have a second card in slot A03 which must be similarly jumpered and identified (Figure 2-6).

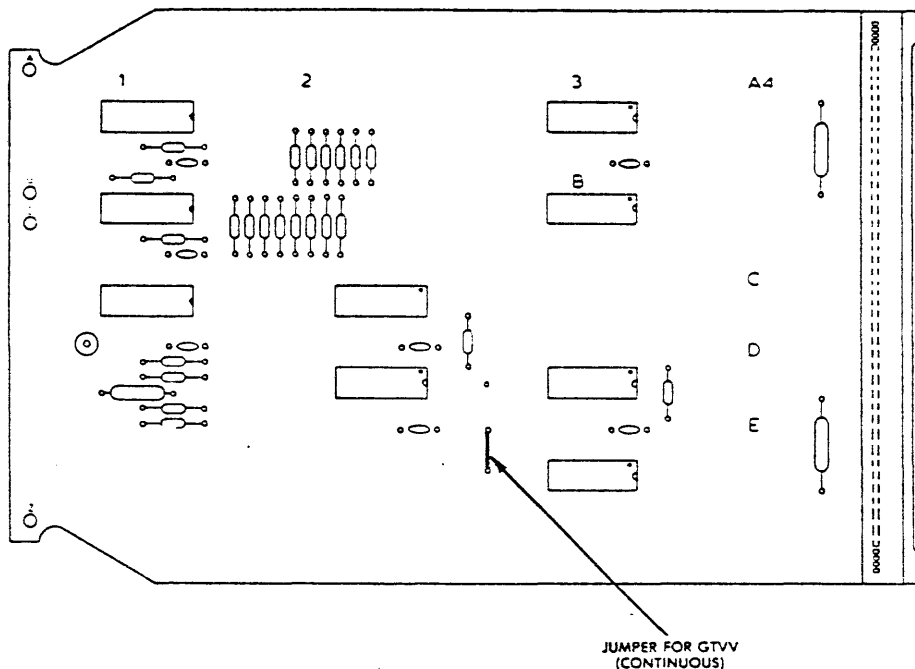

Figure 2-6. __TVV Card Jumpered for A- or B-Cable Continuous

B-cable continuous On newer drives (series code 27 and later), the B-cable signals must be enabled by plugging connector PD90-14, 13 into JD90-14, 13 on the lower right corner of the logic backplane. Dual channel drives have a second connector PD90-12, 11 which must be plugged into JD90-12, 11, immediately to the right of the first connector, (Figure 2-7).

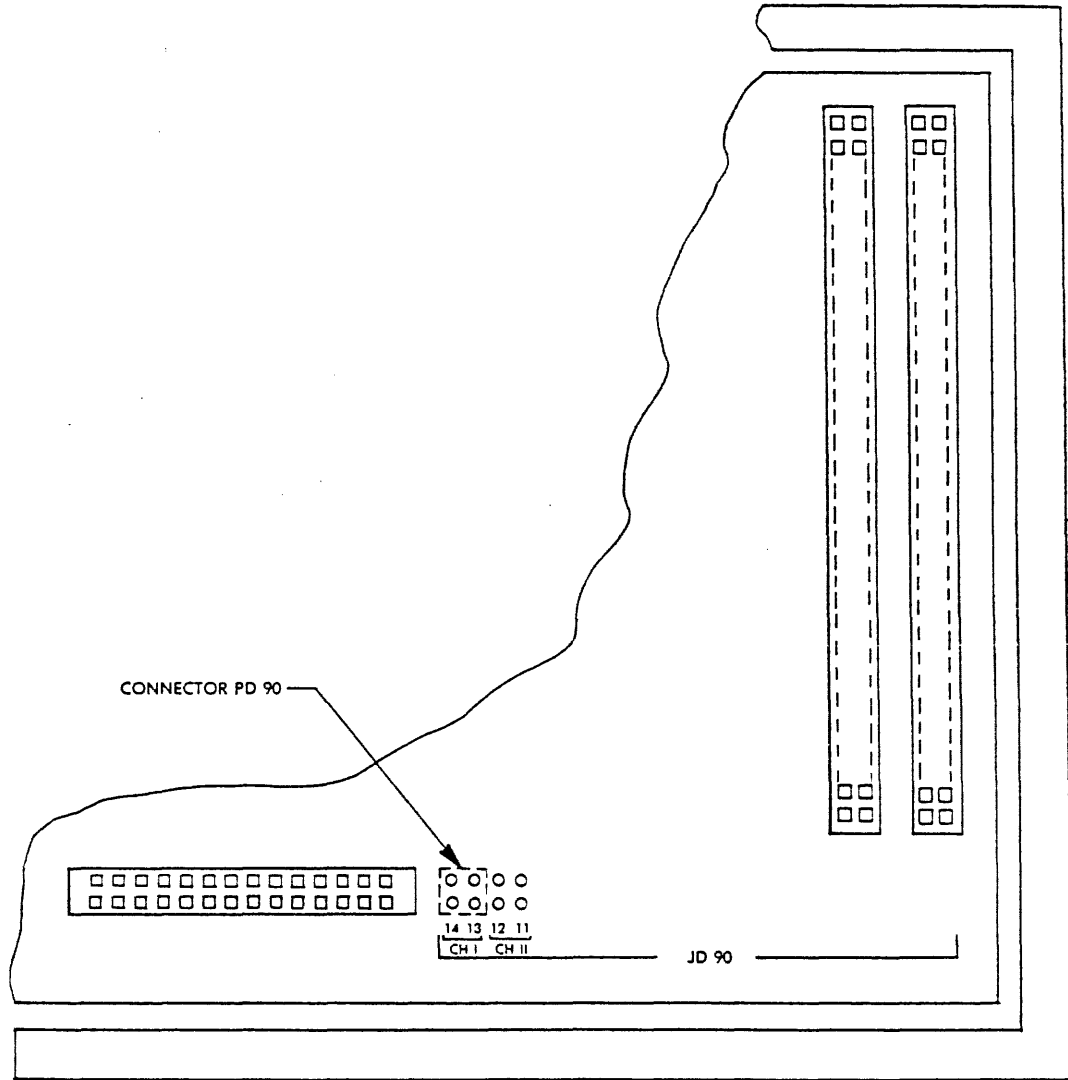

Figure 2-7. 9766 B-Cable Index and Sector Plugs

On older drives (prior to series code 27), the index and sector signals must be moved from the A-cable to the B-cable. To do this, remove the following wires from the channel IJ4 I/O connector and insulate them using a heat shrink cap:

IJ4-18, IJ4-48, IJ4-25, IJ4-55.

Relocate the following wires from the channel IJ3 connectors and insert them into the channel IJ2 connector:

FROM	TO
IJ3-18	IJ2-12
IJ3-48	IJ2-24
IJ3-25	IJ2-13
IJ3-55	IJ2-26

Dual channel drives require additional wiring changes. Remove the following wires from the channel IIJ4 I/O connector and insulate them using a heat shrink cap:

IIJ4-18, IIJ4-48, IIJ4-25, IIJ4-55

Remove the following wires from the channel IIJ3 connectors and insert them into the channel IIJ2 connector:

FROM	TO
IIJ3-18	IIJ2-12
IIJ3-48	IIJ2-24
IIJ3-25	IIJ2-13
IIJ3-55	IIJ2-26

Also, the jumper(s) on the __TVV card(s) (slots A01 and A03 for dual channel) must be in the continuous position and the card(s) are identified as GTVV (see Figure 2-6).

2.6 9766 Radial Cabling

The shielded cable I/O adapter bracket (Figure 2-8) is mounted on the left side of the drive (as viewed from the front). Figure 2-9 shows the location of this bracket. The internal A/B-cable assemblies should have been mounted on the bracket and connected to the IF card, in which case follow step 1 and steps 7–11 in the following procedure. If not, do steps 2–6 also. The installation of the internal cables requires the following hardware:

- 10-32 3/8 inch machine screws
- 10-32 hex nuts
- #10 split tooth lock washers
- Connector clip sets

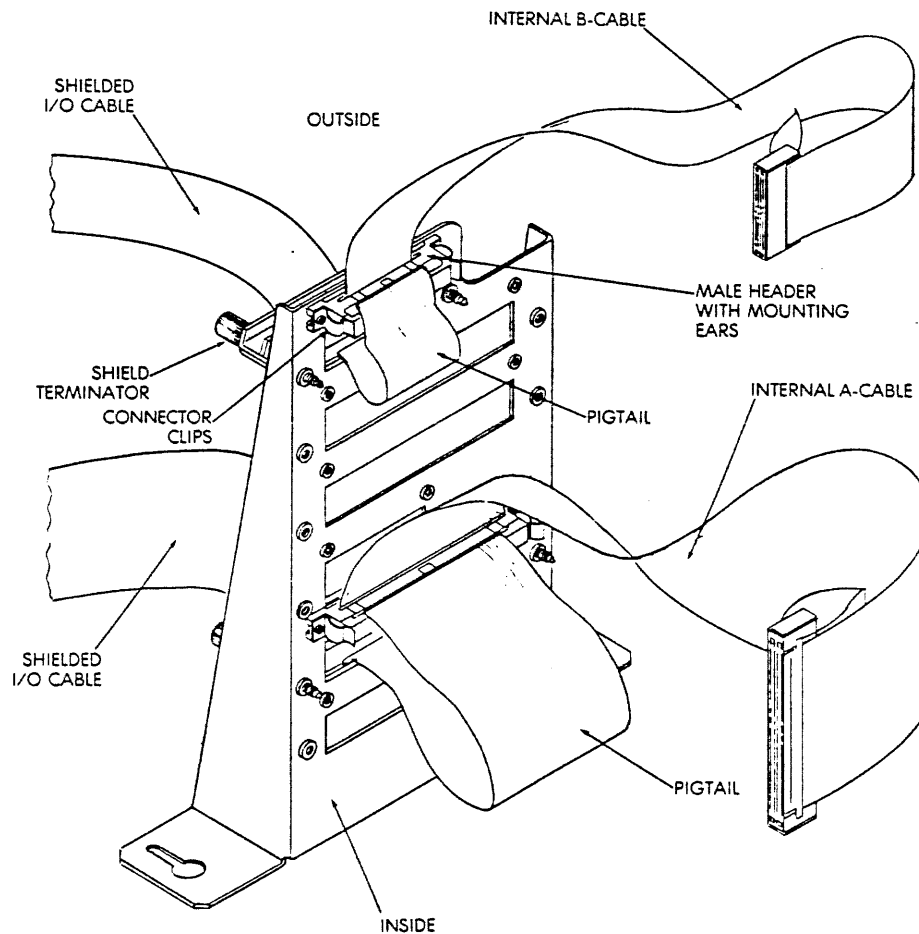

Figure 2-8. 9766 Shielded Cable I/O Bracket

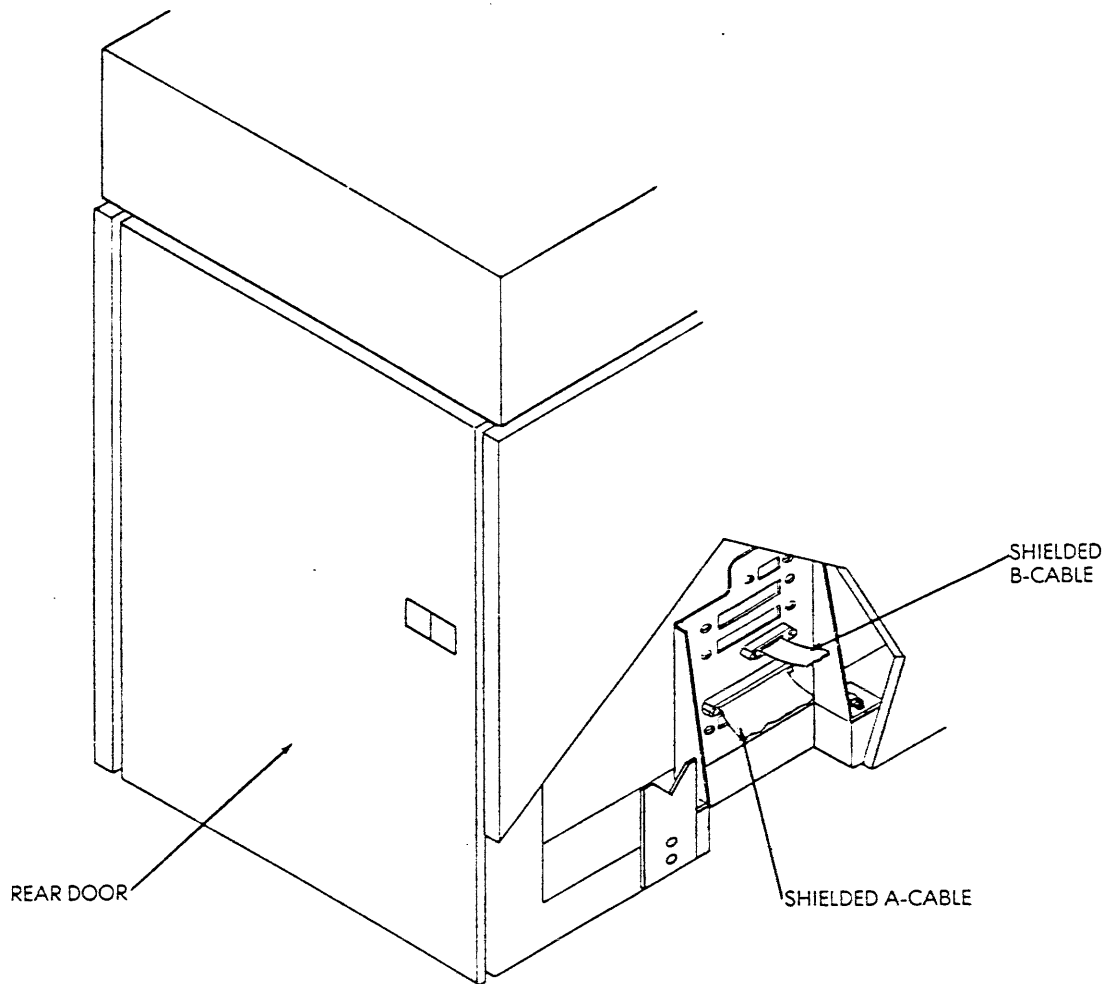

Figure 2-9. 9766 Shielded Cable I/O Bracket Location

1. Remove the left side panel and the adapter bracket.
2. Install a cable clip in each of the ears on the internal B-cable flanged connector. Using the screws, lock washers, and hex nuts provided, mount the header immediately above one of the 26-size ports at the top of the bracket on the inside.
3. Put a half twist in the internal B-cable and connect the other end to IJ2 on the drive interface card. The twist is necessary to maintain proper pin alignment.
4. Repeat steps two and three for the A-cable flanged connector using a 60-size port.
5. Install a terminator at IJ4.
6. Remount the I/O bracket.

7. Feed the pigtails of the external I/O cables through the appropriate slot and mount the shield terminators.
8. Loop the pigtails back and seat the connectors on the A/B-cable flanged connectors on the inside of the bracket.
9. Verify that the internal A/B-cables going to the drive IF card from the adapter bracket have half twists in them. The twist is necessary to maintain proper pin alignment.
10. Remount the bracket and side panel
11. Repeat this procedure until all drives have been connected.

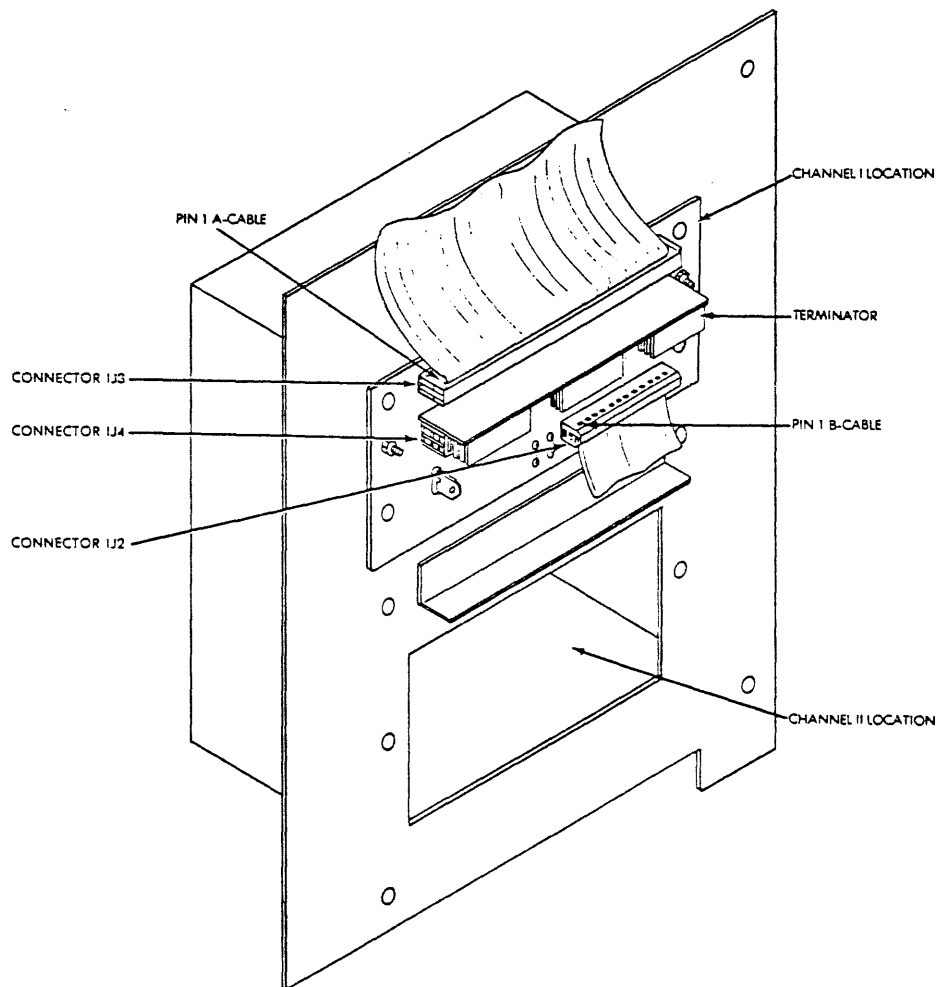

Figure 2-10. 9766 Radial Cabling

2.7 9766 Daisy-chain Cabling

The shielded cable I/O adapter bracket (Figure 2-8) is mounted on the left side of the drive (as viewed from the front). Figure 2-9 shows the location of this bracket. The internal A/B-cable assemblies should have been mounted on the bracket and connected to the IF card, in which case follow step 1 and steps 6—14 in the procedure below. If not, do steps 2—5 also. The installation of the internal cables requires the following hardware:

- 10-32 3/8 inch machine screws
- 10-32 hex nuts
- #10 split tooth lock washers
- Connector clip sets

1. Remove the left side panel and the adapter bracket.
2. Install a cable clip in each of the ears on the internal B-cable flanged connector. Using the screws, lock washers, and hex nuts provided, mount the header immediately above one of the 26-size ports at the top of the bracket on the inside.
3. Put a half twist in the internal B-cable and connect the other end to IJ2 on the drive interface card. The twist is necessary to maintain proper pin alignment.
4. Repeat steps two and three for the A-cable flanged connector using a 60-size port.
5. Remount the I/O bracket.
6. Feed the pigtailed ends of the external I/O cables through the appropriate slots and mount the shield terminators.
7. Loop the pigtailed ends back and seat the connectors on the A/B-cable flanged connectors on the inside of the bracket.
8. Verify that the internal A/B-cables going to the drive IF card from the adapter bracket have half twists in them. The twist is necessary to maintain proper pin alignment.
9. Repeat steps 1—5 for each additional drive if necessary.
10. Insert the pigtail of the outgoing shielded A-cable in the next 60-size port and mount the terminator.
11. Connect the pigtail to IJ4 on the IF card.
12. Replace the side panel.
13. Run the shielded A-cable to the next drive in the chain and repeat whichever of the above steps are applicable.
14. Install a terminator in IJ4 on the last drive in the chain.

For dual channel configurations, repeat the applicable steps in the above procedure. Verify that the internal A/B-cables going to IJ3 and IJ2, respectively, have half twists in them to maintain proper pin alignment. Install a terminator at location IJ4.

Figure 2-11 illustrates daisy-chain cabling for the 9766 drives (single channel shown for clarity).

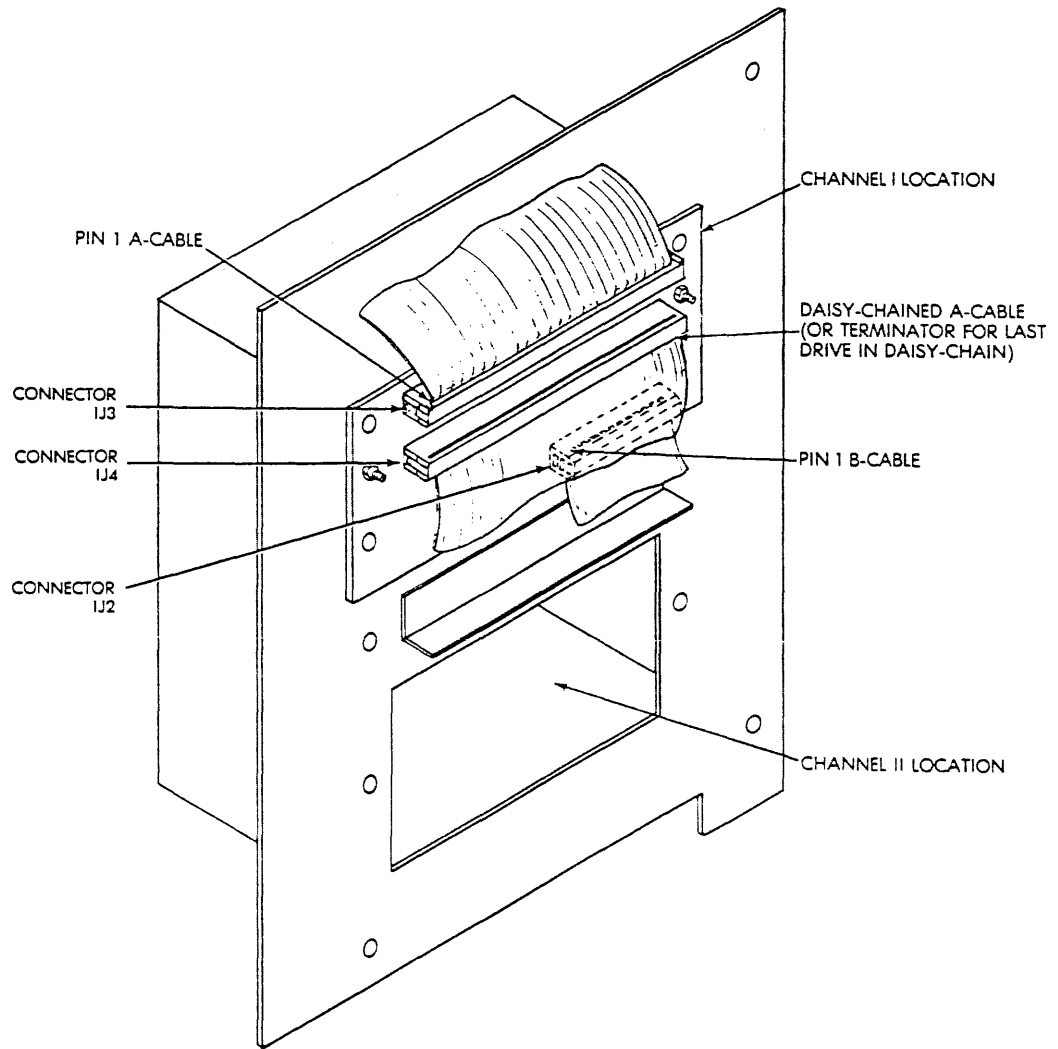

Figure 2-11. 9766 Daisy-chain Cabling

SECTION 3 SI 9775 DISK DRIVE

The SI 9775 is a 675 Mbyte FMD mounted in an FCC-compliant pedestal cabinet.

3.1 9775 Power Requirements

The site must have an AC power source for each drive. Each drive connects to the power source by a 6-foot cord provided with the drive.

Sixty-Hertz drives are supplied with a 3-pin, 20-amp, 240-volt locking power connector (NEMA configuration L6-20P). The mating receptacle must be NEMA configuration L6-20R (e.g., Hubbell 2320, 2323, or 2326; Bryant 70620, or Arrow 6210).

Fifty-Hertz drives are not supplied with a power connector.

The voltage requirements and maximum current requirements are listed in Tables 3-1 and 3-2.

Table 3-1. 9775 Voltage Requirements

VAC	RANGE (VAC)	FREQUENCY (HZ)	RANGE (HZ)
208	179—223	60	59.0—60.6
230	198—246	60	59.0—60.6
220	198—235	50	49.0—50.5
240	216—257	50	49.0—50.5

Table 2-2. 9775 Maximum Current Requirements

VAC/HZ	CURRENT IN AMPS	
	OPERATING*	STANDBY**
208/60	7.3	3.9
230/60	7.0	3.0
220/50	6.7	3.1
240/50	6.8	3.1

*Carriage and disks in motion

**Disks not rotating

3.2 9775 Grounding Requirements

The site AC power source must provide two types of grounding: safety ground and system ground.

A safety ground is provided by an insulated green (or green with yellow stripe) grounding conductor in the AC power cord. This wire is connected to the drive frame and is grounded to earth through the AC circuit supplying power to the drive. The circuit must include an insulated grounding conductor.

Adequate system grounding can be provided by any of the following methods (listed in preferred order):

Grounded Floor Grid The drives and the controller are connected to a grounded floor grid to ensure a constant ground potential at all connection points. The grid is connected directly to earth ground (Figure 3-1).

Ungrounded Floor Grid The drives and the controller are connected to an ungrounded floor grid. The controller is connected to earth ground, which grounds the grid and the drives (Figure 3-1).

Daisy-chain The drive ground terminals are daisy-chained from drive to drive and then to the controller. The controller is connected to earth ground (Figure 3-2).

The system ground must provide earth ground connection for both AC (frame) ground and DC (logic) ground. Drives are shipped with the AC and DC grounds jumpered together at the grounding block, and only one system ground connection is required. If the installation requires AC and DC grounds to be isolated, the jumper must be removed and both grounds must be connected to earth ground by separate system ground connections. Figure 3-3 illustrates the grounding block, the jumper, and groundstrap placement.

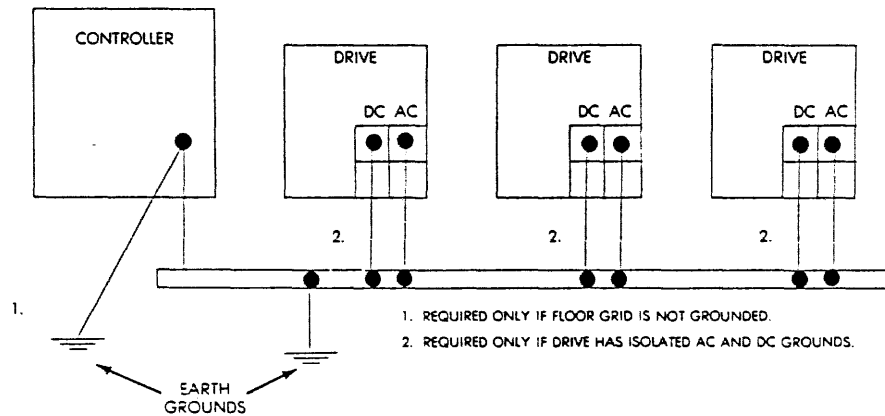

Figure 3-1. 9775 Floor Grid System Grounding

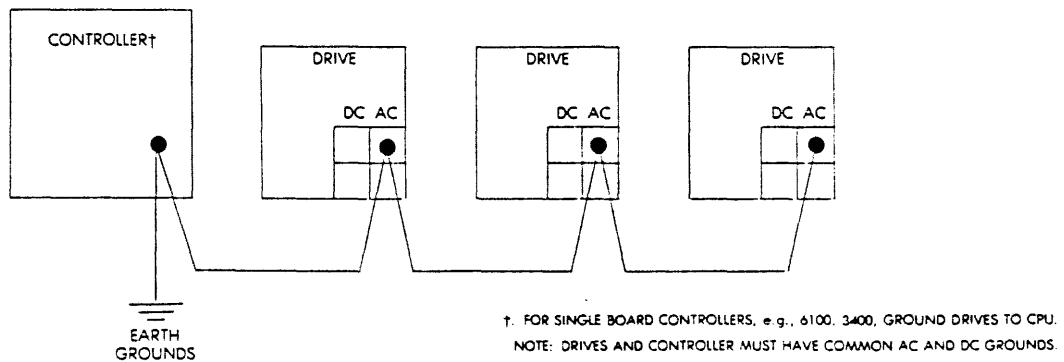
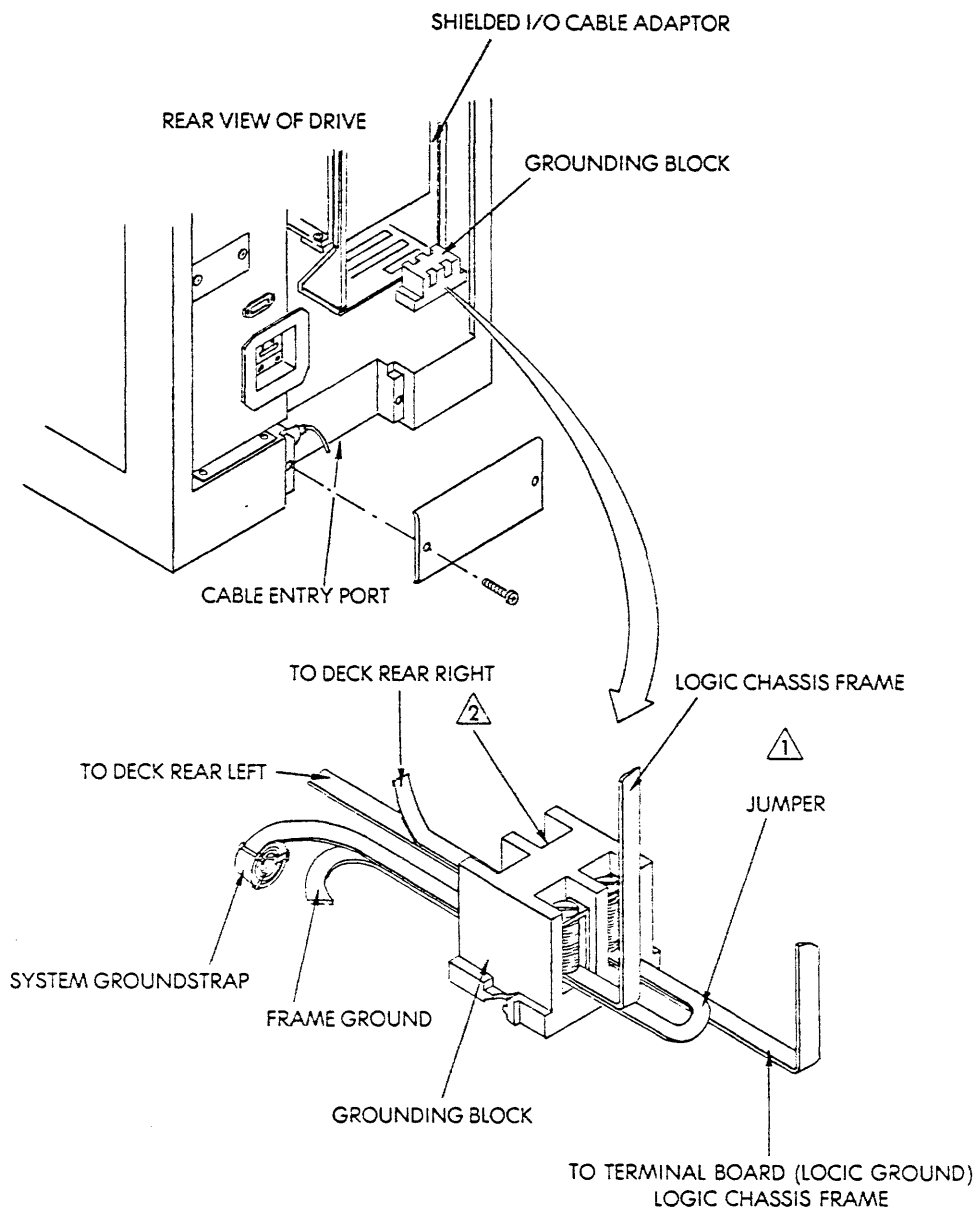

Figure 3-2. 9775 Daisy-Chain System Grounding



1 APPLICABLE ONLY IF DRIVE HAS ISOLATED AC AND DC GROUNDS (JUMPER IS REMOVED).

2 JUMPER IS REMOVED TO ISOLATE AC AND DC GROUNDS.

Figure 3-3. 9775 Grounding Block

3.3 9775 Address Selection

A unit number for this drive is assigned by setting the address selection switches. Numbered 1 through 4, these switches are located on the __LEX card at location B04/C04 (Figure 3-4). The desired address is selected as shown in Table 3-3.

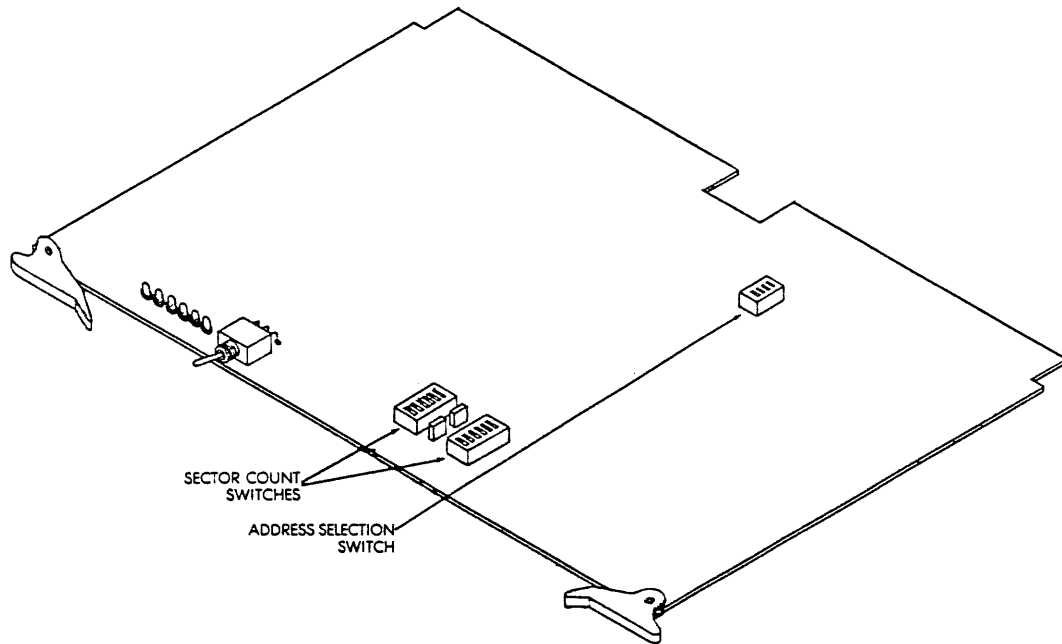

Figure 3-4. 9775 __LEX Board

Table 3-3. 9775 Address Selection Switch Settings

DISK ADDRESS	SWITCH NUMBERS AND SETTINGS			
	SW1	SW2	SW3	SW4
0	ON	ON	ON	ON
1	OFF	ON	ON	ON
2	ON	OFF	ON	ON
3	OFF	OFF	ON	ON
4	ON	ON	OFF	ON
5	OFF	ON	OFF	ON
6	ON	OFF	OFF	ON
7	OFF	OFF	OFF	ON

ON = Closed
OFF = Open

3.4 9775 Sector Count

Sector switches located on a card in the drive logic chassis must be set. On the SI 9775 drive, the card is the __LEX located in slot B04/C04. Figure 3-4 shows the switch location on the __LEX board. The switch settings for specific sector counts are listed in Table 3-4.

Table 3-4. SI 9775 Sector Count Switch Settings

24 SECTORS		32 SECTORS		33 SECTORS		35 SECTORS	
SWITCH#	SETTING	SWITCH#	SETTING	SWITCH#	SETTING	SWITCH#	SETTING
0	ON	0	ON	0	OFF	0	ON
1	ON	1	ON	1	ON	1	ON
2	ON	2	OFF	2	ON	2	ON
3	ON	3	OFF	3	OFF	3	ON
4	OFF	4	OFF	4	ON	4	ON
5	ON	5	ON	5	OFF	5	ON
6	OFF	6	OFF	6	OFF	6	OFF
7	OFF	7	ON	7	ON	7	ON
8	OFF	8	ON	8	ON	8	OFF
9	ON	9	OFF	9	OFF	9	OFF
10	OFF	10	OFF	10	OFF	10	OFF
11	OFF	11	OFF	11	OFF	11	OFF

ON=Closed
OFF=Open

3.5 9775 Drive with CFAF, DFAF, MFAF, WFAF, or AAFAX Card

Unless otherwise specified, this drive is supplied by System Industries with the A-cable gated. Jumpers on the __FAX card (slot A08) are used to change to A-cable continuous or B-cable continuous. Only one option is available at a time.

Drive (CFAF/DFAF card) index/sector signal routing and gating options are as follows:

- A-cable gated** The jumpers on the __FAX card (slot A08) must be configured as shown in Figure 3-5. The card should be labeled as CFAF. Dual channel drives have a second card in slot B08 which must be jumpered and labeled in the same way.
- A-cable continuous** The jumpers on the __FAX card (slot A08) must be configured as shown in Figure 3-6. The card should be labeled as CFAF. Dual channel drives have a second card in slot B08 which must be jumpered and labeled in the same way.
- B-cable continuous** The jumpers on the __FAX card (slot A08) must be configured as shown in Figure 3-7. The card should be labeled as DFAF. Dual channel drives have a second card in slot B08 which must be jumpered in the same way.

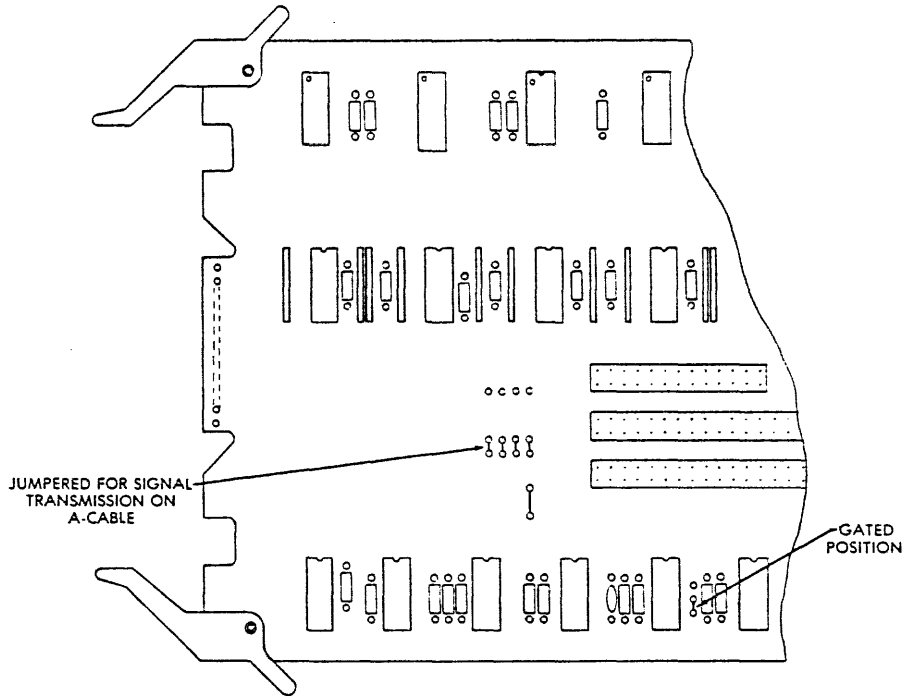

Figure 3-5. FAX Card Jumpered for A-Cable Gated

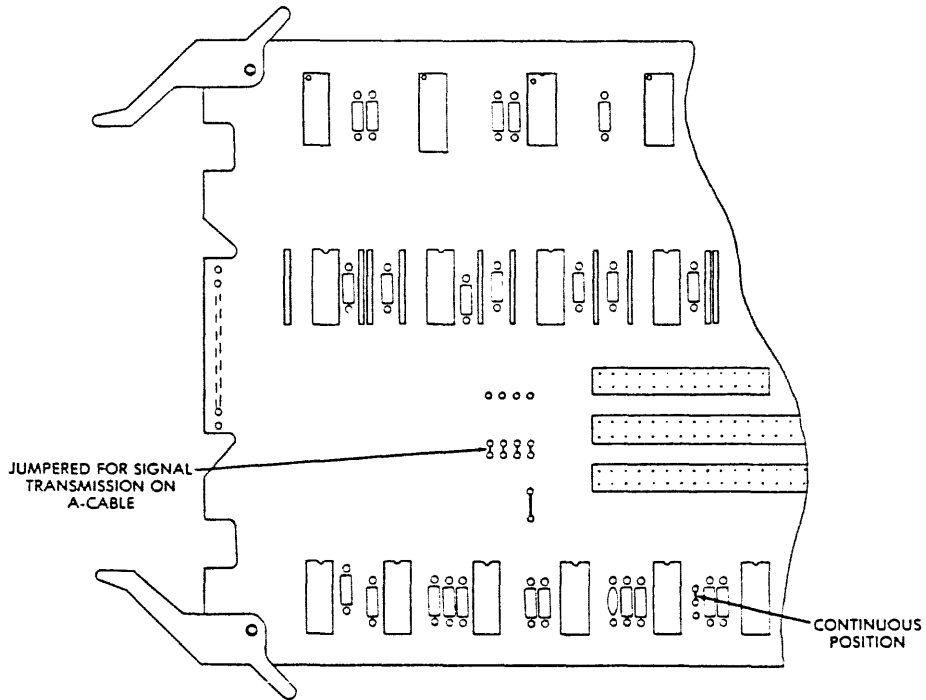

Figure 3-6. FAX Card Jumpered for A-Cable Continuous

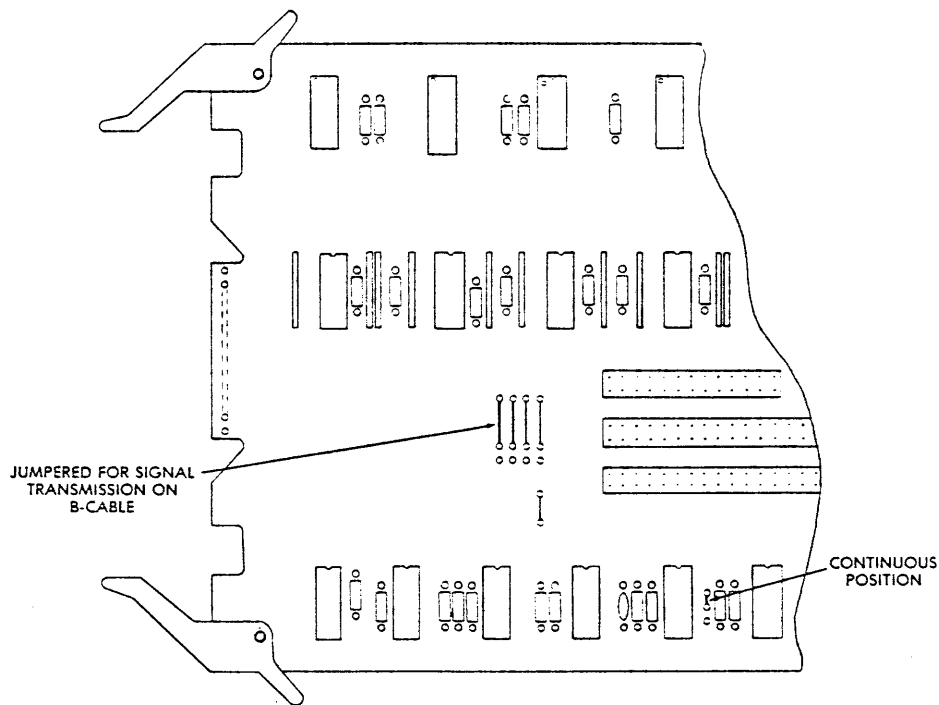

Figure 3-7. MFAFAX Card Jumped for B-Cable Continuous

Unless otherwise specified, the drive with MFAFAX card is supplied by System Industries with the A-cable gated and B-cable continuous options installed. A jumper on the MFAFAX card (slot A08) is used to disable the B-cable continuous option when it is in the 'A' position.

SI 9775 (MFAFAX, WFAFAX or AAFAX card) index/sector signal routing and gating options are as follows:

- A-cable gated** This option is always available. The jumper plug on the MFAFAX card (slot A08) can be in either position (see Figure 3-8).
- A-cable continuous** This option is not available.
- B-cable continuous** The jumper plug on the MFAFAX card (slot A08) must be in the 'A+B' position. Dual channel drives have a second card in slot B08 which must be similarly jumpered (see Figure 3-9).

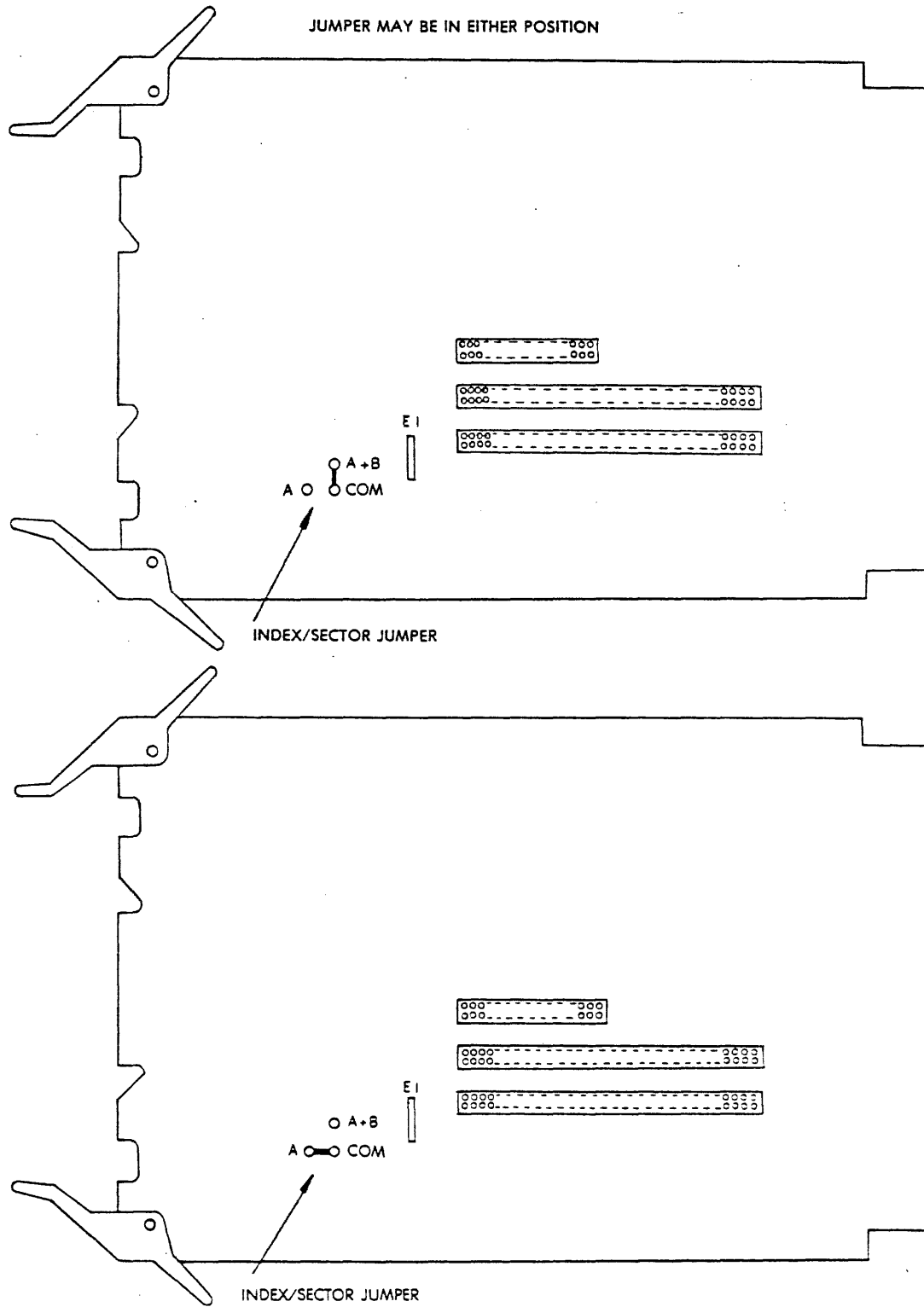

Figure 3-8. MFAX, WFAX, or AAFAX Card Jumpered for A-Cable Gated

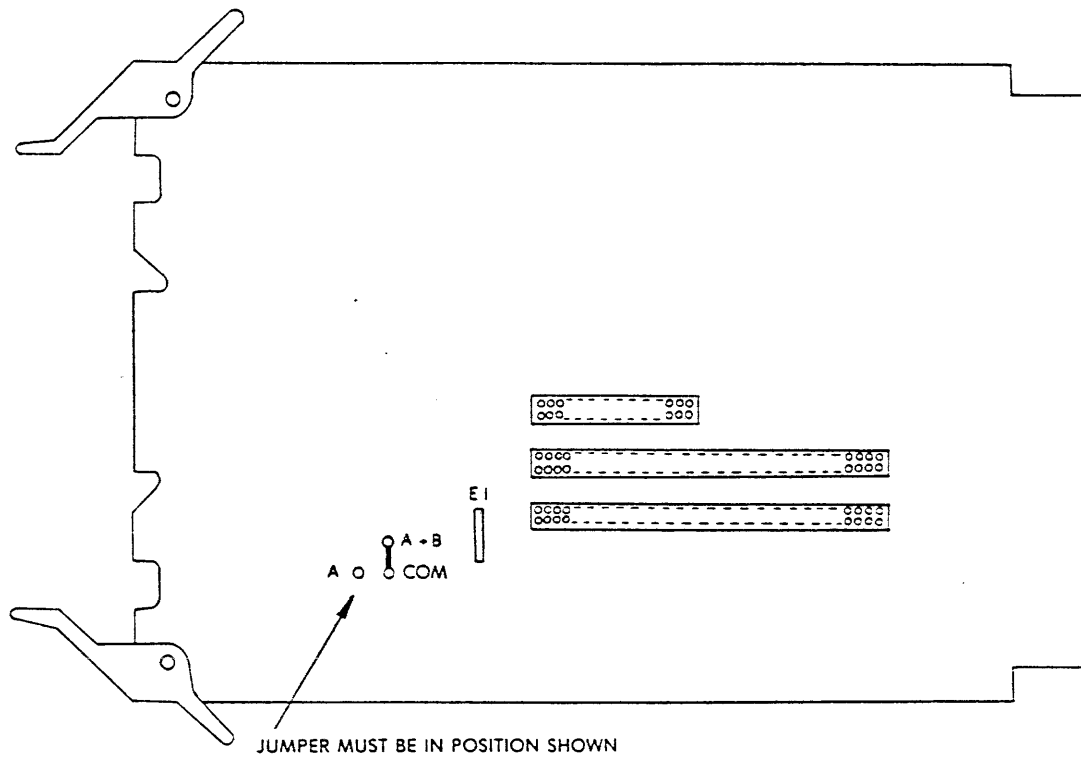

Figure 3-9. MFAX, WFAX, or AAFAX Card Jumpered for B-Cable Continuous

3.6 9775 Radial Cabling

This procedure requires the following mounting hardware:

- Two sets of connector clips
- Four split tooth lockwashers

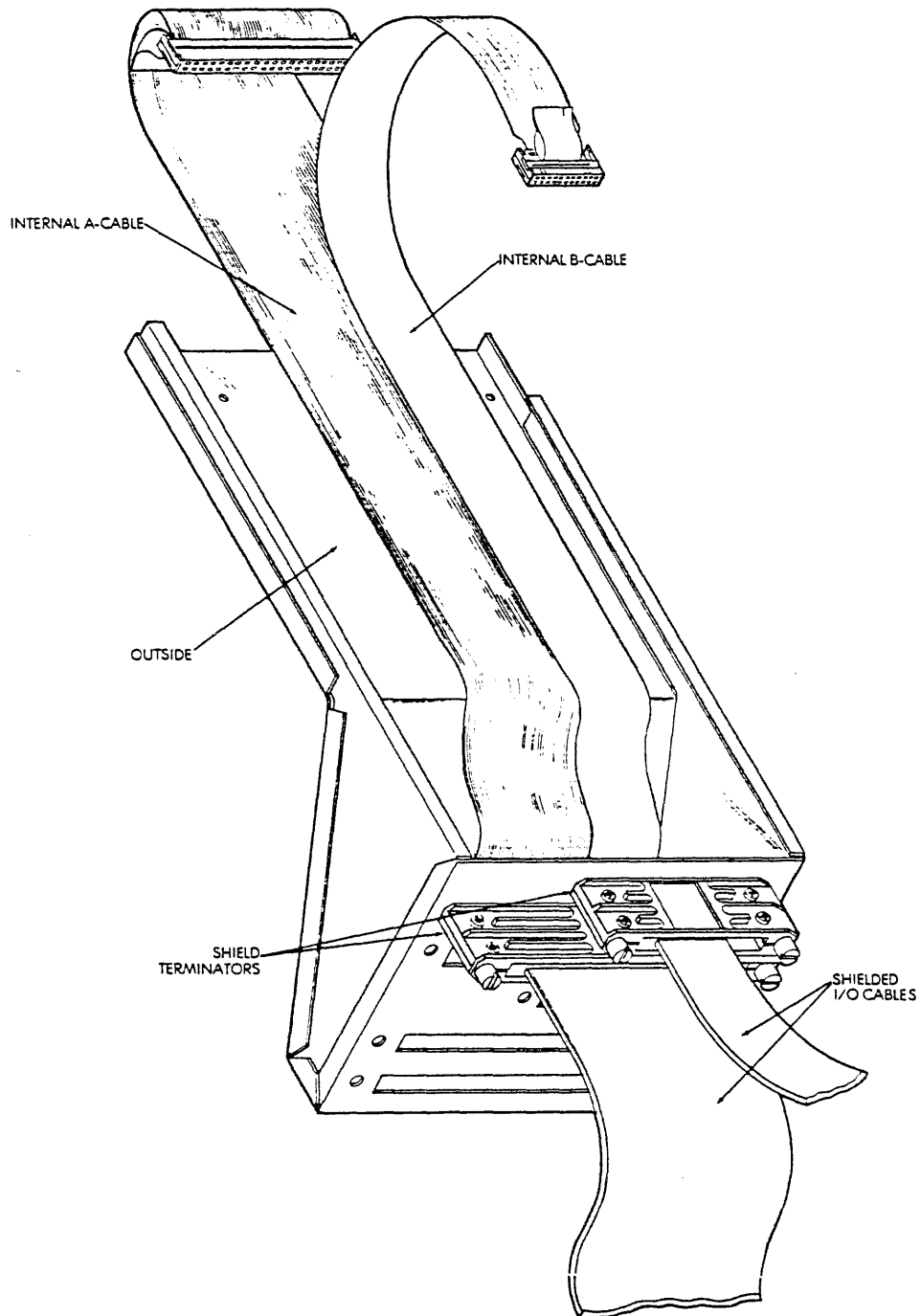

Figure 3-10. SI 9775 Shielded Cable I/O Bracket

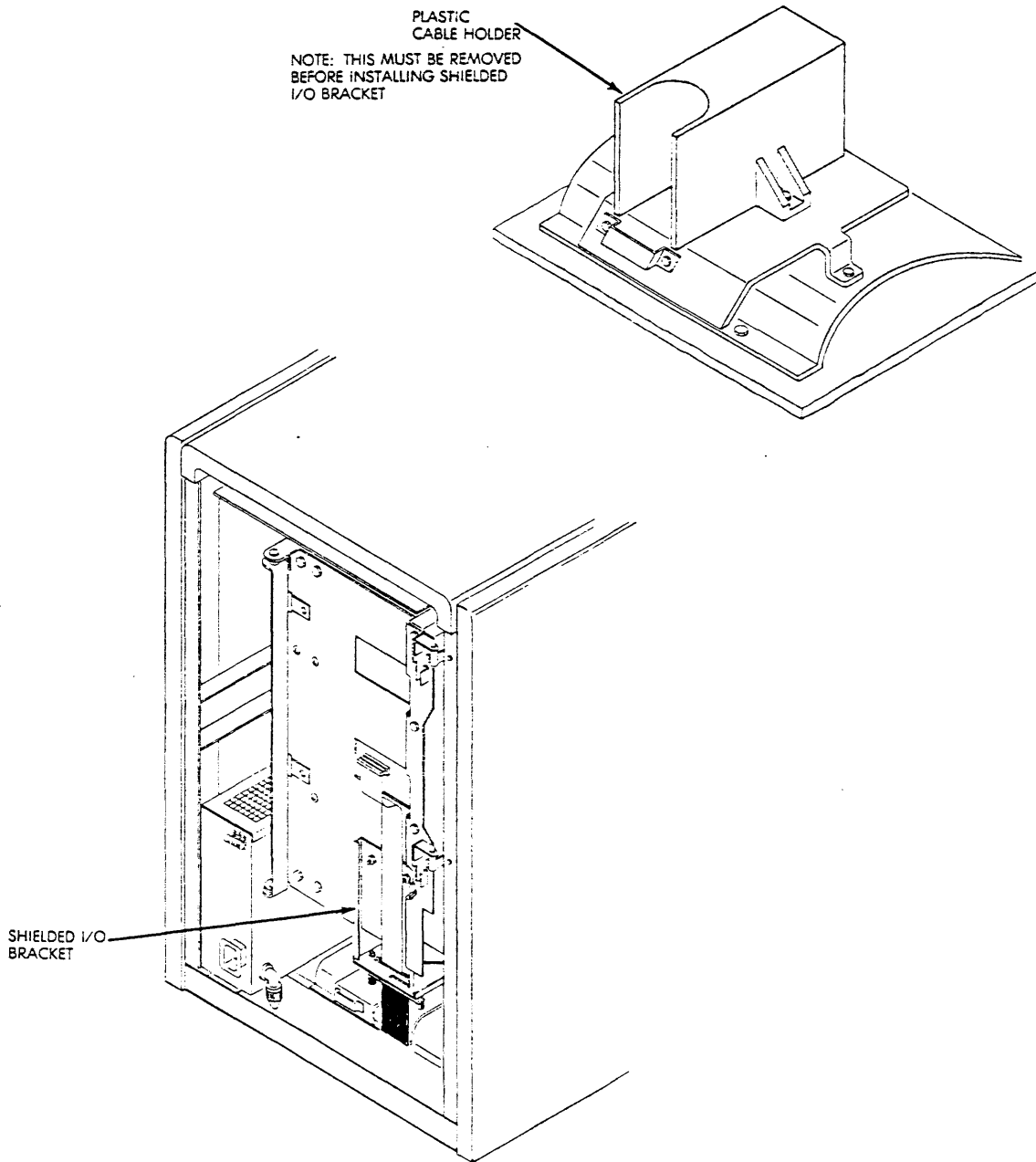

Figure 3-11. SI 9775 Shielded Cable I/O Bracket Location

1. Open the rear door of the drive cabinet and locate the sheet metal assembly that covers the card cage. Remove the cable clamp and mount the bracket using the same hardware that held the cable clamp in place.
2. Mount cable clips on the internal A/B-cable male connectors.
3. Connect the A/B-cables to IJ3 and IJ2 respectively on the SMD interface card.
4. Install a terminator at IJ4.
5. Insert the pigtail ends of the shielded external A/B-cables in the ports at the bottom of the bracket and attach the shield terminators.
6. Connect the pigtails of the shielded I/O cables to the internal cables.

Figure 3-12 illustrates 9775 drive cabling.

For dual channel configurations, repeat steps 2—6 above, connecting the internal A/B-cables to IIJ3 and IIJ2 respectively and installing a terminator at IIJ4.

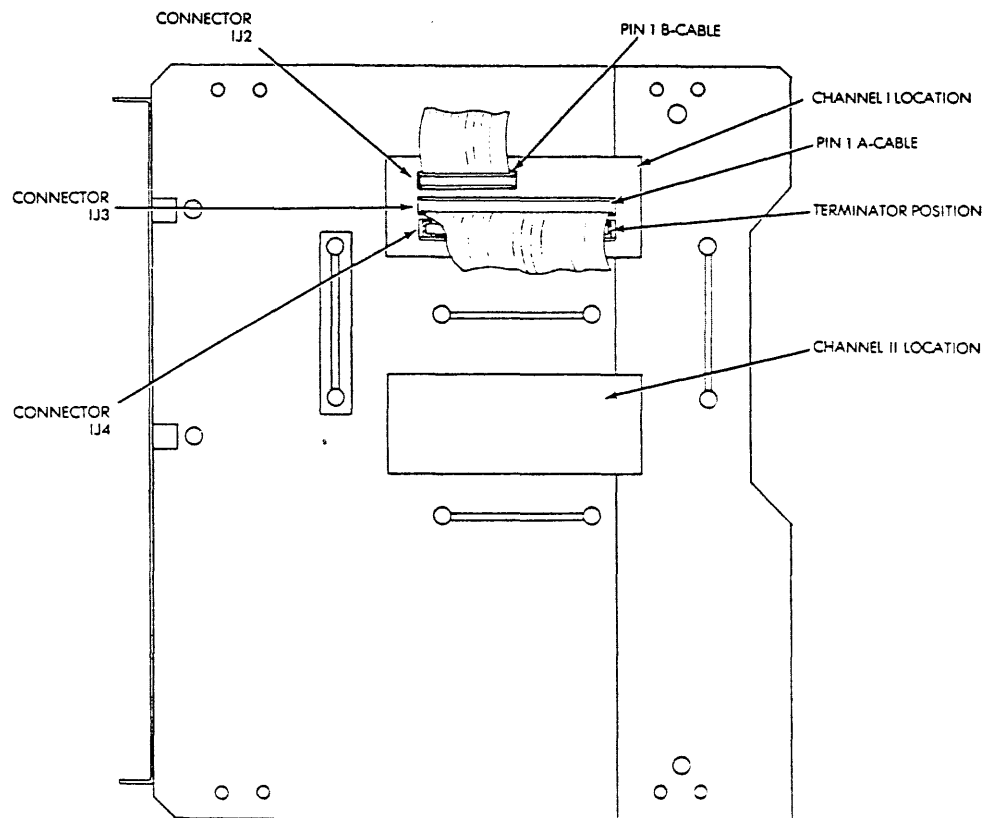

Figure 3-12. SI 9775 Radial Cabling

3.7 9775 Daisy-chain Cabling

This procedure requires the following mounting hardware:

- Two sets of connector clips
- Four split tooth lockwashers

Figure 3-13 illustrates 9775 daisy-chain cabling.

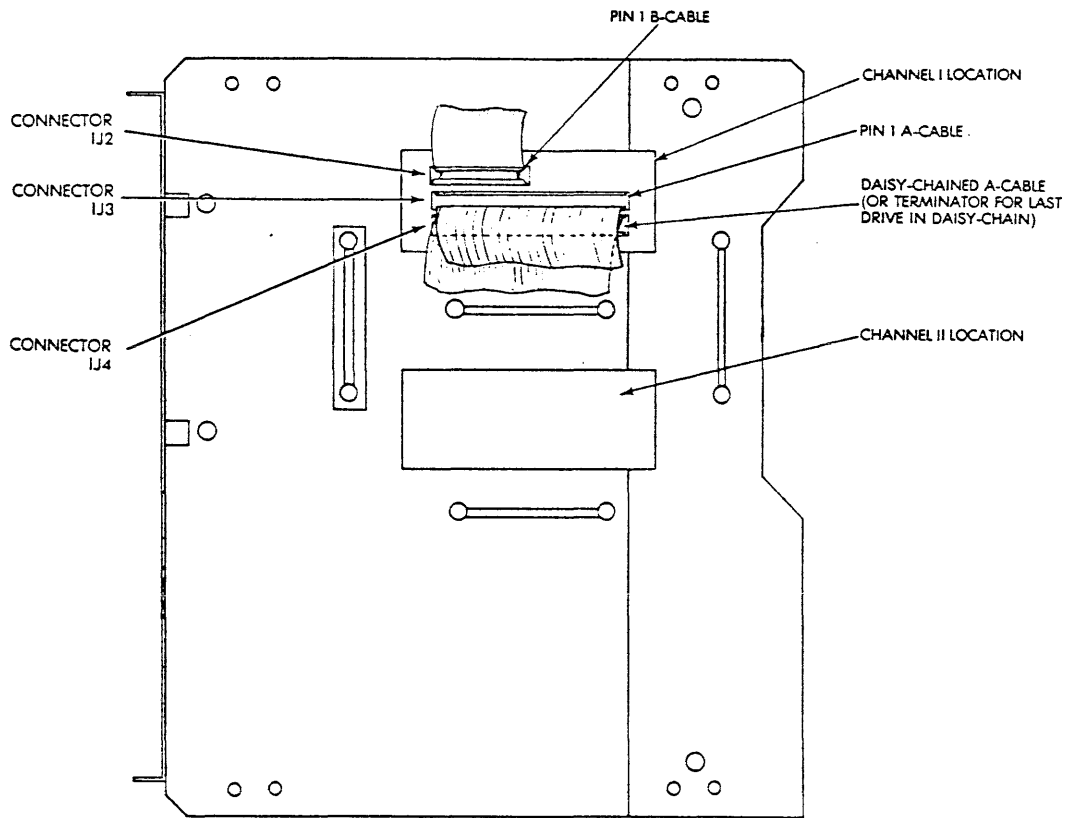

Figure 3-13. 9775 Daisy-chain Cabling

1. Open the rear door of the drive cabinet and locate the sheet metal assembly that covers the card cage. Remove the cable clamp and mount the I/O adapter using the same hardware that held the cable clamp in place.
2. Mount cable clips to the internal A/B-cable male connectors.

3. Connect the A/B-cables to IJ3 and IJ4 respectively on the SMD interface card.
4. Insert the pigtail ends of the shielded external A/B-cables from the controller in the ports at the bottom of the bracket and attach the shield terminators.
5. Connect the pigtails of the shielded I/O cables to the internal cables.
6. Connect an internal A-cable to IJ4.
7. Mount the outgoing shielded A-cable terminator to the I/O bracket and connect the cable to the IJ4 internal A-cable.
8. Route the external A-cable to the next drive in the chain.
9. Connect a shielded B-cable from the controller to each drive in the chain.
10. Repeat the above procedure for each drive in the chain, and install a terminator in IJ4 of the last drive in the chain.
11. For dual-channel configuration repeat steps 2—10 attaching the second set of A/B-cables to IJ3 and IJ2 respectively. Install the terminator at IJ4 on the last drive in the chain.

SECTION 4 SI 9751 DISK DRIVE

The SI 9751 is a 475 Mbyte fixed media disk drive to be rack mounted in an FCC-compliant cabinet.

4.1 9751 Power Requirements

The site must provide an AC power source for each drive.

The drive draws all power from its own power supply unit (an integral part of the drive), which is connected to the site AC power.

Sixty-Hertz power supply units are supplied with a 3-pin, 15-amp, 125-volt power connector (NEMA configuration 5-15P). The mating receptacle must be NEMA configuration 5-15R; (e.g.) Hubbell 5262.

Fifty-Hertz power supply units are not supplied with a power connector.

The AC voltage requirements and the maximum current requirements of the power supply unit are listed in Tables 4-1 and 4-2.

Table 4-1. SI 9751 Voltage Requirements

VAC	RANGE (VAC)	FREQUENCY (HZ)	RANGE (HZ)
100	90—110	50/60	±2
120	108—132	60	±2
220	198—242	50	±2
240	216—264	50	±2

Table 4-2. SI 9751 Maximum Current Requirements

VAC	HZ	OPERATING CURRENT (AMPS)
100	50/60	5.7/5.4
120	60	4.6
220	50	2.8
240	50	2.6

The taps on the power supply control panel must be changed according to the voltage/frequency of the AC input, as shown in Table 4-3.

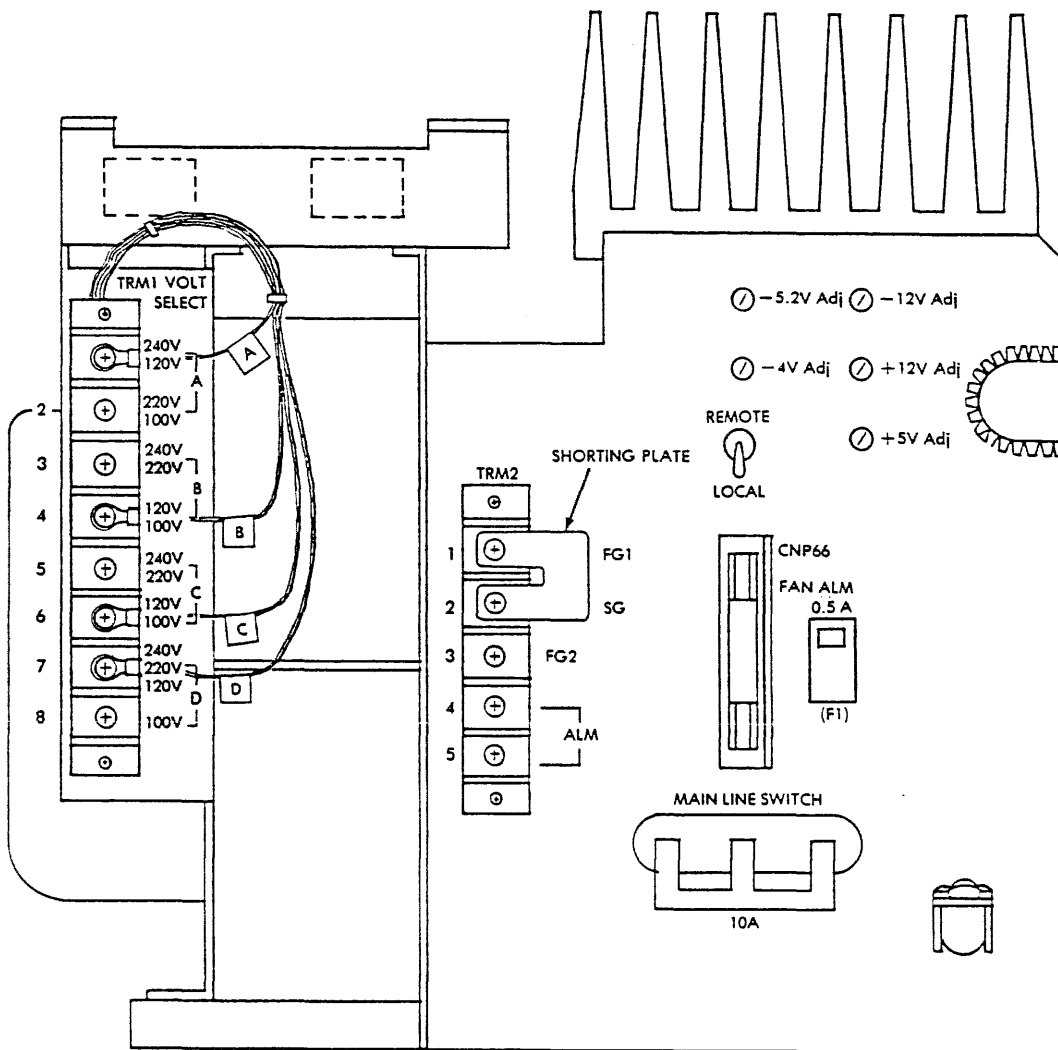

Figure 4-1. SI 9751 Power Supply Unit Control Panel

Table 4-3. SI 9751 Voltage Selection Wire-to-Tap Configuration

VAC (HZ)	TAP NUMBERS			
	WIRE A	WIRE B	WIRE C	WIRE D
100 (50/60)	2	4	6	8
120 (60)	1	4	6	7
220 (50)	2	3	5	7
240 (50)	1	3	5	7

4.2 9751 Grounding Requirements

The grounding lugs are defined as follows:

1. SG is the signal (DC) ground. It is isolated from AC ground within the drive.
2. FG1 is the frame (AC) ground. It is a direct short to the drive chassis.
3. FG2 is a high impedance AC ground connected to FG1 through a 510K ohm resistor. SG is connected to FG2 for shipment.

The drives should always be grounded. If cable lengths exceed ten feet or the drives are daisy-chained, grounding is mandatory. Grounding should be done with insulated flat braided wire.

Grounding methods vary depending upon the site and the system configuration. The following four methods of grounding are listed in order of preference.

1. Isolate FG and SG. Connect SG to controller signal ground. Connect FG1 to the controller chassis (AC ground).
2. Connect SG to FG1, and connect SG to controller signal ground.
3. Connect SG and FG1. Connect FG1 to the controller chassis (AC ground).

The controller should always be earth grounded to ensure that the drives are grounded through the controller. Preferably the drive(s), controller, and CPU have a common AC branch circuit.

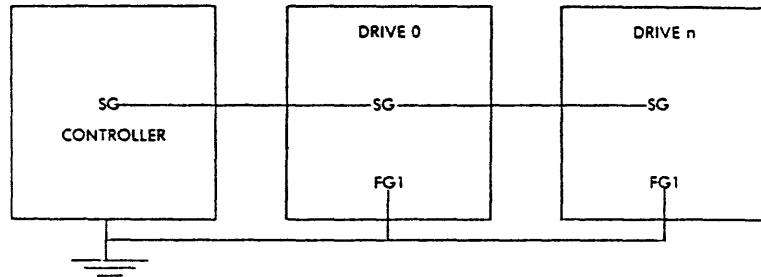

Figure 4-2. SI 9751 Grounding Method 1

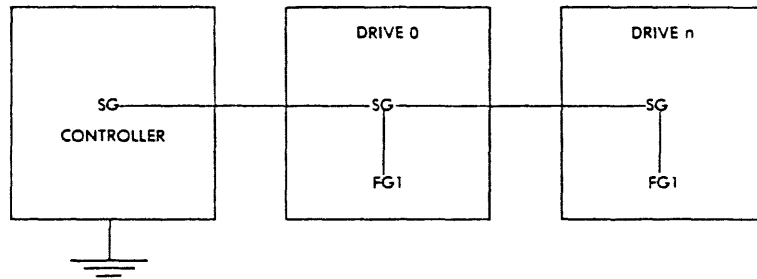

Figure 4-3. SI 9751 Grounding Method 2

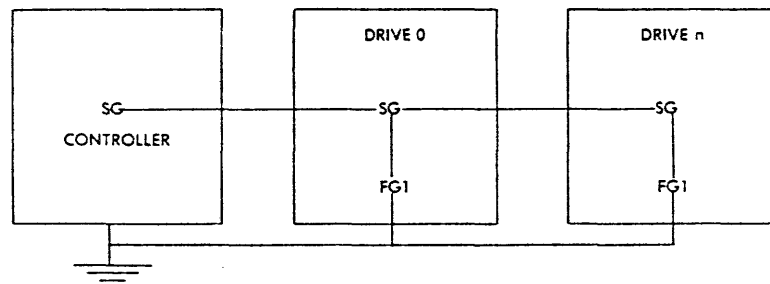

Figure 4-4. SI 9751 Grounding Method 3

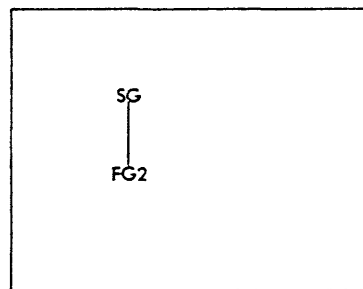

Figure 4-5. Grounding Scheme for Shipping

4.3 9751 Address Selection

Switch pack (CNJ46), located on the interface PCB (DQEMU) sets the drive address (0-7) (see Figure 4-6). Table 4-4 lists the switch settings. Only the first three switches (1, 2, and 3) set the address.

Table 4-4. SI 9751 Address Selection Switch Settings

DISK ADDRESS	SWITCH NUMBERS AND SETTINGS		
	SW1	SW2	SW3
0	OFF	OFF	OFF
1	ON	OFF	OFF
2	OFF	ON	OFF
3	ON	ON	OFF
4	OFF	OFF	ON
5	ON	OFF	ON
6	OFF	ON	ON
7	ON	ON	ON

ON = CLOSED
OFF = OPEN

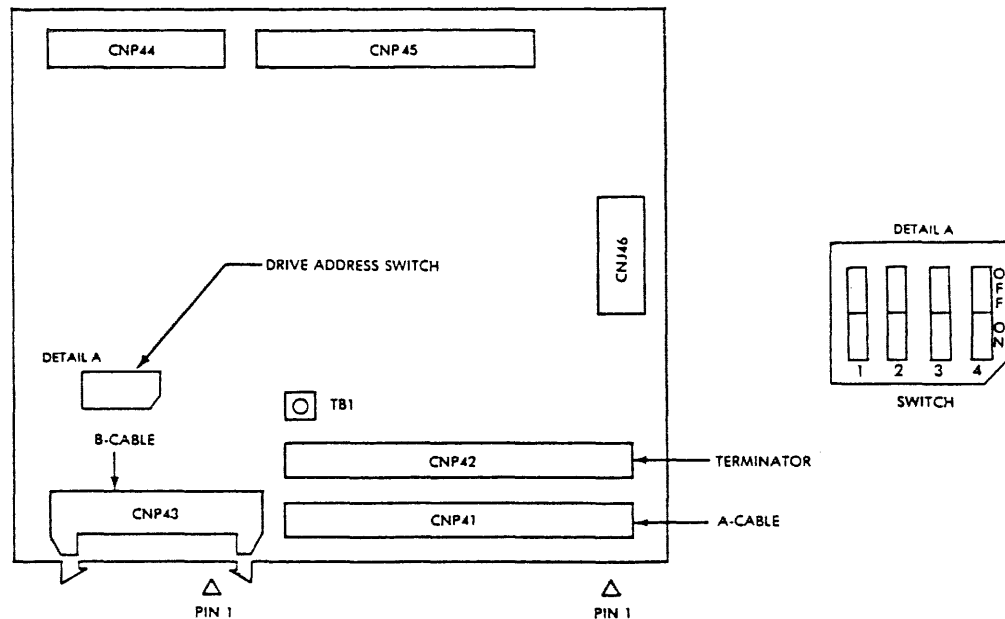

Figure 4-6. SI 9751 Interface PCB (DQEMU)

4.4 9751 Sector Count

The sector count is set by installing jumper plugs on four short circuits (SH09) on the drive logic board. The 16-pin short circuits are at grid locations BC7, BD7, BE7, and BF7. Pin 1 is in the lower right corner, pin 16 in the lower left corner (see Figures 4-7, 4-8, and 4-9). The illustration in Figure 4-9 shows the short circuits configured for 48 sectors per track.

The jumper settings listed in Table 4-4 apply to sector counts required by various controllers. The 3100 series, 3400 series, and 9900 controllers, and the 6100 controller (6100-6021 or 6100-6002) require 48 sectors per track. If the 9900 controller is in RP06 emulation mode with bad block replacement (BBR) enabled, the drive must be configured for 47 sectors per track. Noninterleaved 3400 controllers and 9900 controllers (RP06) require 46 sectors per track. SDA50 and QDA50 controllers must be set for 41 sectors per track.

Table 4-5. SI 9751 Sector Count Jumper Settings

SECTORS PER TRACK	GRID LOCATIONS			
	BC7	BD7	BE7	BF7
	PINS TO BE JUMPERED			
48 SECTORS (3100 Series, 3400 Series, 9900)	2-3 6-7 10-11 12-13	3-4 6-7 9-10 13-14	3-4 5-6 10-11 13-14	3-4 6-7 10-11 13-14
48 SECTORS (6100)	2-3 6-7 9-10 13-14	3-4 6-7 9-10 13-14	3-4 5-6 10-11 13-14	3-4 6-7 10-11 13-14
47 SECTORS (9900 RP06 with BBR)	2-3 5-6 9-10 13-14	2-3 6-7 9-10 13-14	3-4 5-6 10-11 13-14	3-4 6-7 10-11 13-14
46 SECTORS (3400 Series noninterleaved)	2-3 5-6 10-11 13-14	3-4 5-6 9-10 13-14	3-4 5-6 10-11 13-14	3-4 6-7 10-11 13-14
46 SECTORS (9900 - RP06)	3-4 6-7 9-10 13-14	3-4 5-6 9-10 13-14	3-4 5-6 10-11 13-14	3-4 6-7 10-11 13-14
41 SECTORS (SDA50/QDA50)	3-4 5-6 9-10 12-13	3-4 5-6 10-11 12-13	3-4 5-6 10-11 13-14	3-4 6-7 10-11 13-14*
35 SECTORS	2-3 5-6 10-11 13-14	3-4 5-6 10-11 13-14	2-3 5-6 10-11 13-14	3-4 6-7 10-11 13-14
44 SECTORS (QDA40)	2-3 5-6 9-10 12-13	2-3 5-6 9-10 13-14	3-4 5-6 10-11 13-14	3-4 6-7 10-11 13-14

*SPARE
ON = CLOSED
OFF = OPEN

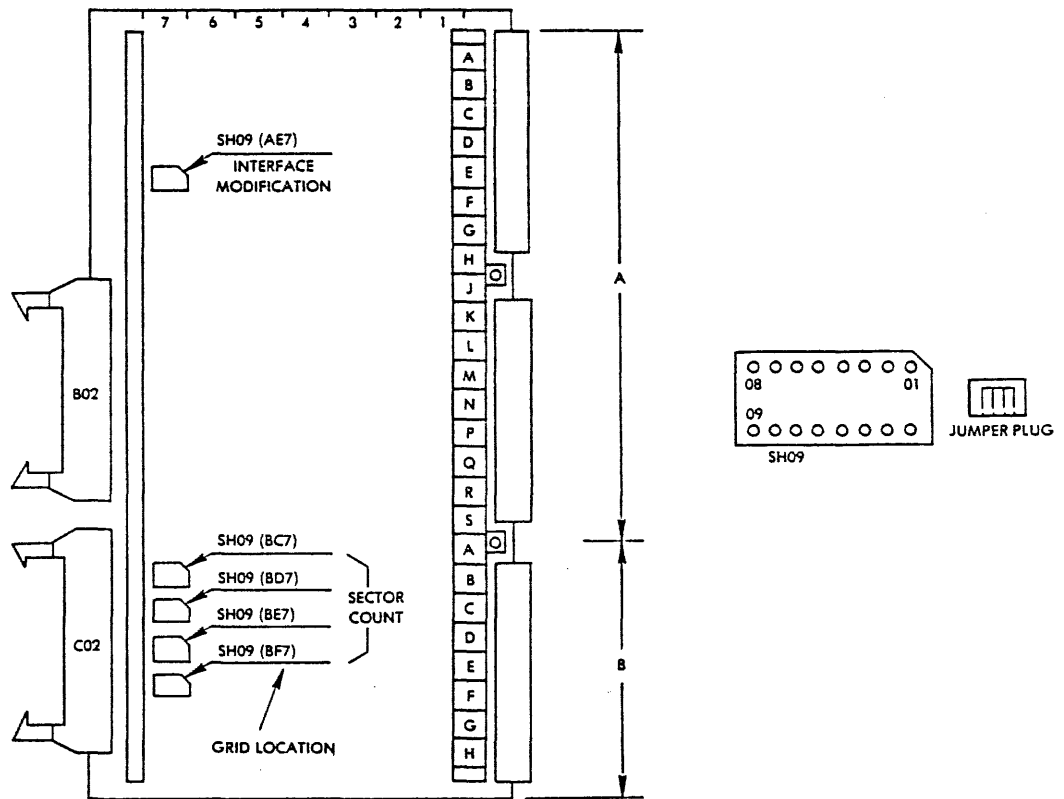

Figure 4-7. SI 9751 Logic PCB

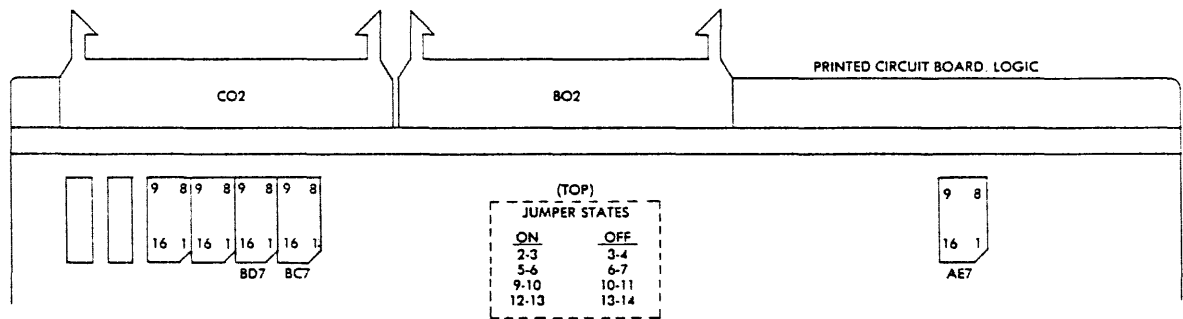

Figure 4-8. SI 9751 Sector Jumper States

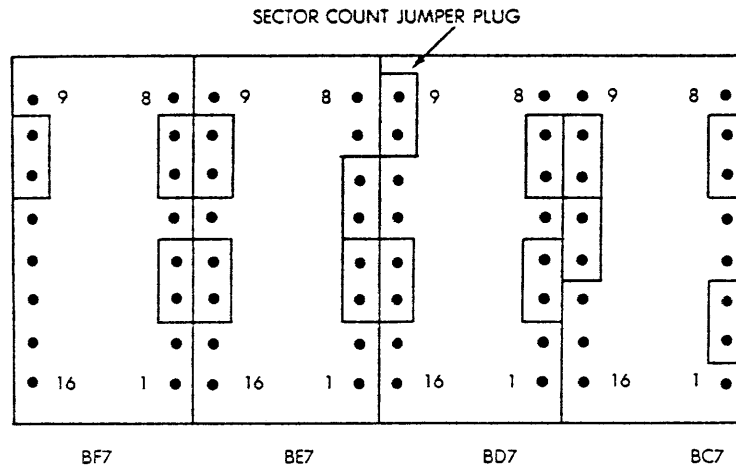

Figure 4-9. SI 9751 Jumper Settings for 48 Sectors

4.5 9751 Drive Index and Sector Signals

This drive has one option: A-cable gated and B-cable continuous. No modifications can be made.

4.6 9751 Cabling

The instructions in this paragraph assume the use of a System Industries FCC-Compliant Cabinet(s). Cable configurations vary depending on the following:

- Type of controller
- Location of the controller
- Number of cabinets being interconnected
- Dual or single channel operation

If the controller is a 99XX or a QDA50, it can be housed in the same cabinet as the drives. If these drives are the only ones in the system, there will be no drive cables connected to the transition panel in the cabinet. The only external cables will be those running to the CPU. For details on drive cabling to QDA50 controllers (they do not support radial cabling) refer to the appropriate user's guide.

Single-board controllers will be in the host CPU or an expansion cabinet. These controllers support only daisy-chain cabling.

4.6.1 9751 Radial Cabling

These procedures assume a 99XX controller housed in the same cabinet as the drives.

1. Run an internal A-cable from the controller RDI board to CNP41 on the drive interface card.
2. Run an internal B-cable from the RDI board to CNP43 on the drive interface card.
3. Install a terminator at CNP42.
4. Repeat steps 1—3 for each drive (maximum of four).
5. For dual channel configurations, connect a second set of A- and B-cables to CNP51 and CNP53 on the dual channel interface board (DQFMU) and install a terminator at CNP52.

4.7 9751 Daisy-chain Cabling

The following instructions assume the use of a 99XX controller and two SI FCC-compliant cabinets with a maximum configuration of one controller and four drives per cabinet.

1. Run an internal A-cable and an internal B-cable from the RDI board to connectors CNP41 and CNP43 respectively on the first drive.
2. Run an internal A-cable from drive connector CNP42 on the first drive to CNP41 on the second drive. Repeat this until the fourth drive in the cabinet has been connected.
3. Run an A-cable from CNP42 on drive four to a feedthrough connector on the transition panel. Label it CNP42.
4. Run three B-cables from the DI board to CNP43 on drives 2, 3, and 4.
5. Run four B-cables from the last DI board to four connectors on the transition panel. Identify the cables and the connectors on the transition panel, e.g., CNP43 drive 5... CNP43 drive 8.
6. Insert the pigtail of a shielded A-cable into one of the ports on the transition panel assembly and mount the shield terminator.
7. Mate the connector on the end of the shielded cable to the CNP43 feedthrough connector.
8. Route the A-cable to the transition panel in the second cabinet, terminate the shield, and mate the connector on the pigtail with the 60-connector feedthrough connector on the panel.
9. Run an internal A-cable from the panel to CNP41 on drive 5. Then from CNP42 to CNP41 on drive 6. Repeat this until all drives in the second cabinet have been connected. Install a terminator in CNP42 on the last drive.

10. Insert four shielded B-cables in the available ports on the transition panel assembly, mount the terminators, and connect the cables to the CNP43 connectors on the panel. Identify the cables.
11. Route the four shielded B-cables to the second cabinet and repeat step 10.
12. Run internal B-cables from the CNP43 connectors on the panel to CNP43 on each drive in the second cabinet.

For dual channel configuration repeat the above procedure using connectors CNP51, 52, and 53 on the drives' dual-channel cards. The drives will be connected to a second 99XX controller.

Figure 4-10 shows the locations of the SMD interfaces on the 9751 interface board.

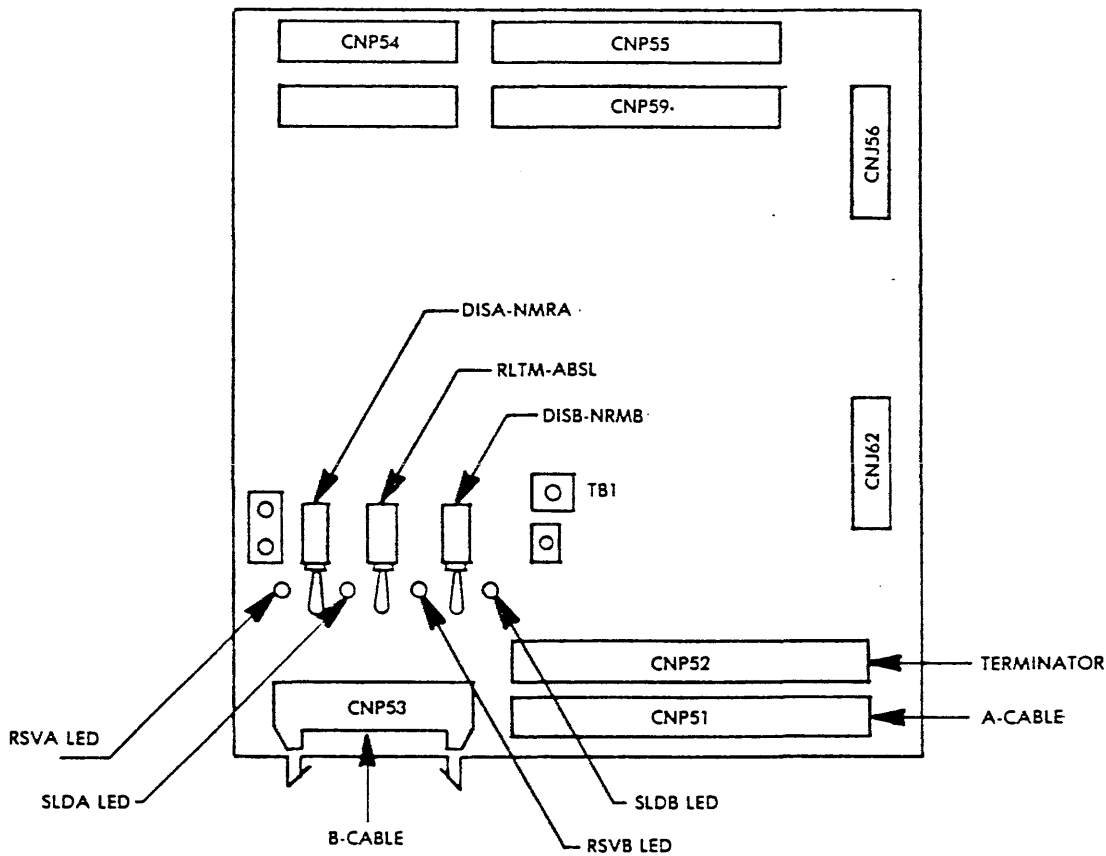

Figure 4-10. 9751 Interface Board (DQEMU), Daisy-chain, Single Channel



SECTION 5

SI 9722 DISK DRIVE

The SI 9722 is a 168 Mbyte FMD that is mounted in an FCC-compliant cabinet.

5.1 9722 Power Requirements

Each drive draws all power from its power supply unit, which is separate from the drive. Ideally, each drive's power supply has a dedicated AC line. However, in cases where there are more than six drives or six drives and a 9X00 controller in one 60-inch cabinet, power cabling could become a problem. That is because all AC power must be routed through an AC power distribution box to a power strip, and the power strip might have only six outlets.

Since 9722 drives can be pair mounted on trays in a standard 19-inch rack, the power cabling problem can be solved by jumpering the AC power on the power supply units. Thus only one AC line is required for two drives. All drive pairs can be connected to one AC line in this way.

CAUTION

In the above configuration, since the power supplies are jumpered in parallel, it is possible to power down one drive independently should one of the pair fail or need servicing. However, for safety reasons the AC power line serving both drives should be disconnected. If one of the jumpered pair is taken off-line for reasons not requiring physical contact with the drive or power supply interiors, the AC line can remain connected.

This drive does not need separate power supplies for 50 or 60 Hz operation because of the AC voltage group select switch on the power supply unit. The drive is powered by DC voltage (+5, +24, and -12 VDC).

In 60 Hz operation the power supply requires a 3-pin, 15-amp, 125-volt power connector (NEMA configuration 5-15P) The mating receptacle must be a NEMA configuration 5-15R, e.g., Hubble 5262.

5.1.1 Power Supply Unit

The power supply unit is mounted at the rear of the drive and is easily accessed by pulling the drive forward on its mounting rails. The following controls, connections, and indicators are on the power supply unit control panel:

- AC input lugs
- Main line switch/circuit breaker
- AC input voltage selection switch
- Frame and signal ground terminals
- Power-on indicator light
- Power and device alarm lights
- +5 VDC adjustment potentiometer

5.1.2 AC Voltage Selection

There are two groups of AC voltages:

- 100 VAC at 50/60 Hz 115 VAC at 60 Hz 120 VAC at 60 Hz
- 220 VAC at 50 Hz 240 VAC at 50 Hz

The unit should come with the switch already set for the appropriate AC voltage group. If not, the setting will have to be changed.

The switch is covered by a plate that locks the switch and serves to prevent inadvertent change from one AC voltage group to another. Remove the plate and reset the switch. Turn the retainer plate over and replace it (Figure 5-1).

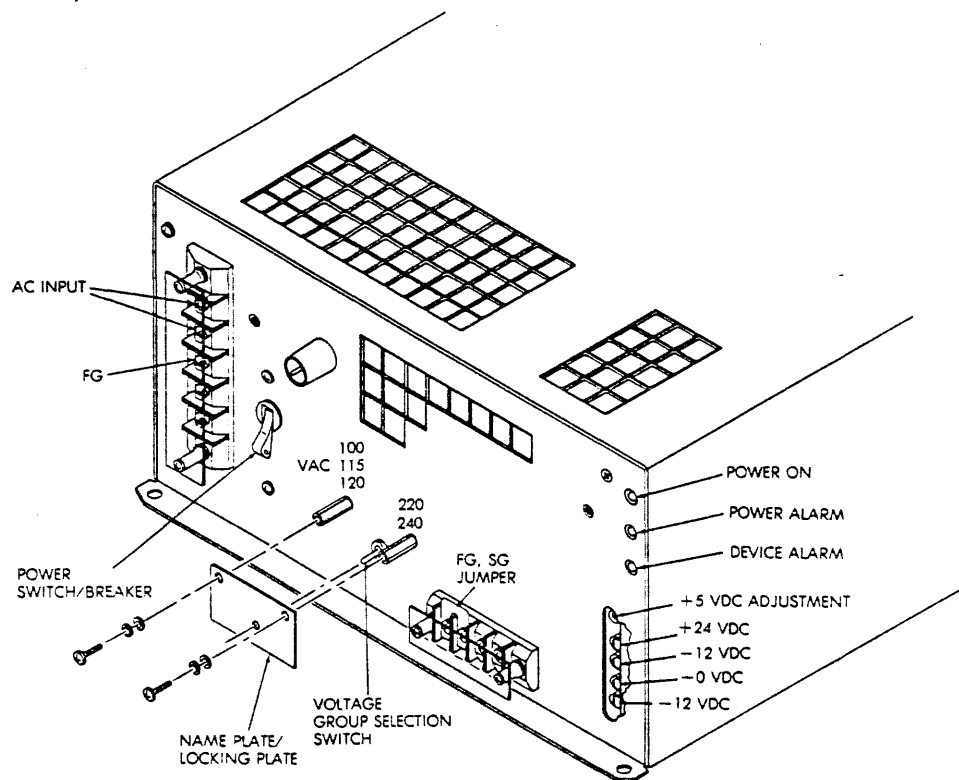

Figure 5-1. 9722 Power Supply Control Panel

AC voltage specifications are in Table 5-1, DC in Table 5-2, and AC current specifications in Table 5-3.

Table 5-1. SI 9722 AC Voltage Specifications

VAC	RANGE (VAC)	FREQUENCY (HZ)	RANGE (HZ)
100	90—110	50/60	48.0—51.0/ 57.6—61.2
115	101—126	60	57.6—61.2
120	108—132	60	57.6—61.2
220	198—242	50	48.0—51.0
240	216—264	50	48.0—51.0

Table 5-2. SI 9722 DC Voltage Specifications

VOLTAGE	RANGE	CURRENT
+5 VDC	+4.85 to +5.15	4.8A
-12 VDC	-11.4 to -12.6	4.0A
+24 VDC	+21.6 to +26.4	4.2A

Table 5-3. SI 9722 Maximum Current Requirements

VAC	HZ	OPERATING CURRENT (AMPS)
100	50/60	3.5
115	50/60	3.3
120	60	3.2
220	50	1.8
240	50	1.7

5.1.3 9722 Power/Device Alarm Indicators

If the power alarm indicator light goes on, any of the following could have occurred:

- +5 VDC over current
over voltage
no voltage
- -12 VDC over current
no voltage
- +24 VDC over current
no voltage
- Overheating within the power supply
- AC output to the fan: over current

The device alarm lamp going on indicates that the thermal switch on the drive fan unit has closed.

5.2 9722 Grounding Requirements

The signal ground (SG) and frame ground (FG) are isolated in this drive. If it is necessary to connect the two, this can be done by using the SG grounding lug at the back of the drive. Normally, SG to FG connection is made by a jumper strap on the ground terminal strip of the power supply (see Figure 5-2).

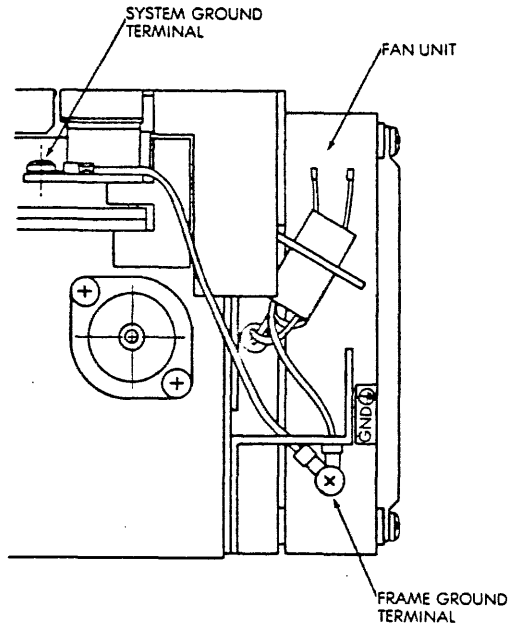

Figure 5-2. SI 9722 Signal Ground to Frame Ground Jumper Strap

The drive must always be grounded, and the grounding should be done with insulated flat braided wire. Grounding schemes will vary depending on site and system configuration.

The controller should always be grounded to earth, thereby ensuring that the drive is grounded through the controller. Ideally, the drive(s), CPU, and controller would share a common AC branch circuit.

The recommended grounding scheme is shown in Figure 5-3.

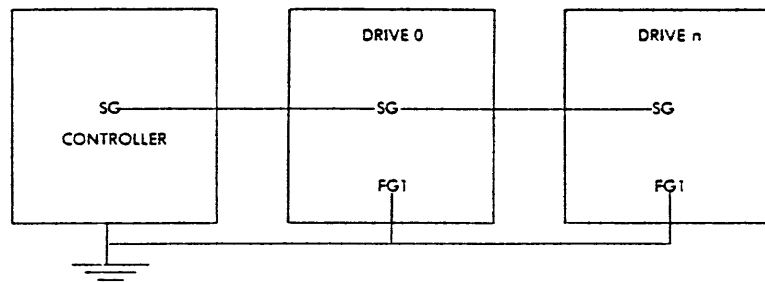

Figure 5-3. SI 9722 Grounding Method 1

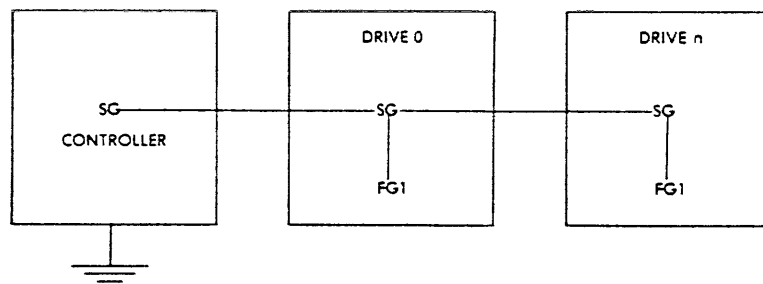

Figure 5-4. SI 9722 Grounding Method 2

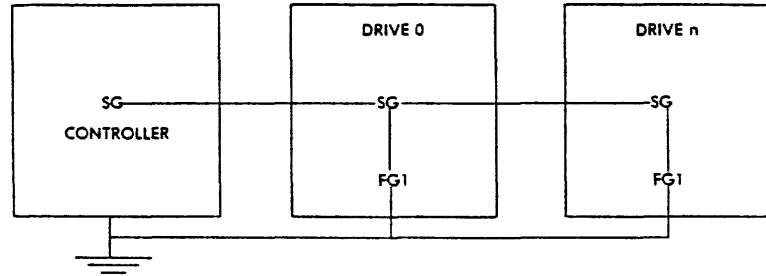

Figure 5-5. SI 9722 Grounding Method 3

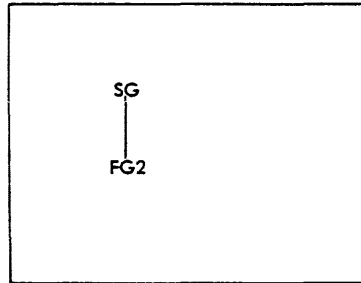

Figure 5-6. Grounding Scheme for Shipping

5.3 9722 Address Selection

Drive address, or unit number, is determined by setting switches one through three (S1 - S3) on switch pack SW1 located at E3 on the drive's interface PCB (CZFM) (see Figure 5-7). The settings are listed in Table 5-4.

Table 5-4. SI 9722 Address Selection Switch Settings

DEVICE ADDRESS	SWITCH SETTINGS		
	S1	S2	S3
0	OFF	OFF	OFF
1	ON	OFF	OFF
2	OFF	ON	OFF
3	ON	ON	OFF
4	OFF	OFF	ON
5	ON	OFF	ON
6	OFF	ON	ON
7	ON	ON	ON

5.4 9722 Sector Count

Two switch packs SW2 and SW3 at locations A26 and A24, respectively, on the drive interface PCB (CZFM) determine the sector count (Figure 5-7). The settings for 24, 29, 32, 33, and 35 sectors are listed in Table 5-5.

NOTE

The 29 sector setting is for SDA50 and QDA50 controllers only.

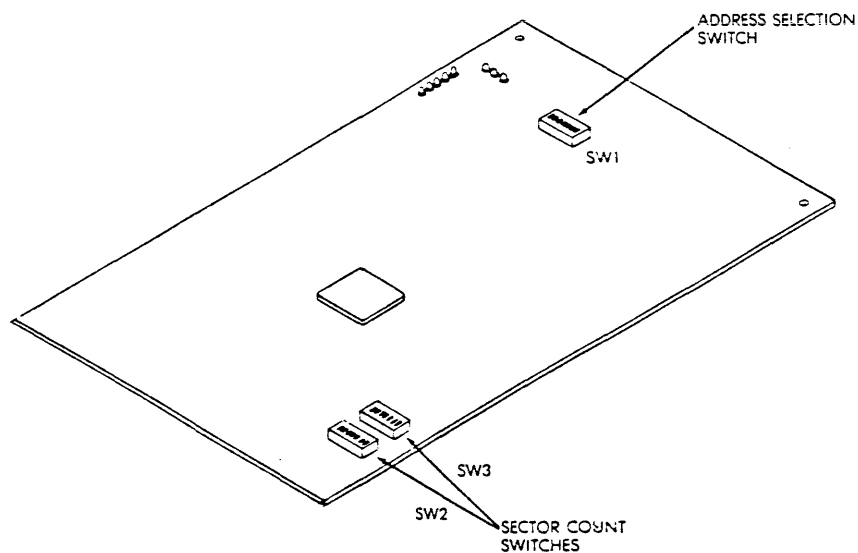

Figure 5-7. 9722 Address and Sector Count Switch Locations on CZFM

Table 5-5. SI 9722 Sector Count Switch Settings

24 SECTORS		29 SECTORS*		32 SECTORS		33 SECTORS		35 SECTORS	
SWITCH#	SETTING	SWITCH#	SETTING	SWITCH#	SETTING	SWITCH#	SETTING	SWITCH#	SETTING
SW2 1	ON	SW2 1	OFF	SW2 1	ON	SW2 1	ON	SW2 1	ON
2	OFF	2	ON	2	ON	2	ON	2	OFF
3	ON	3	OFF	3	ON	3	OFF	3	OFF
4	OFF	4	OFF	4	ON	4	ON	4	ON
5	ON	5	OFF	5	ON	5	OFF	5	OFF
6	OFF	6	OFF	6	ON	6	ON	6	OFF
7	ON	7	ON	7	ON	7	ON	7	ON
SW3 1	OFF	SW3 1	ON	SW3 1	OFF	SW3 1	OFF	SW3 1	OFF
2	ON	2	OFF	2	OFF	2	OFF	2	OFF
3	ON	3	ON	3	ON	3	ON	3	ON
4	OFF	4	OFF	4	OFF	4	OFF	4	OFF
5	OFF	5	OFF	5	OFF	5	OFF	5	OFF
6	OFF	6	OFF	6	OFF	6	OFF	6	OFF
7	OFF	7	OFF	7	OFF	7	OFF	7	OFF

*SDA50E and QDA50E controllers

5.5 9722 Drive Index and Sector Signals

This drive has one configuration: A-cable gated and B-cable continuous. No modifications can be made.

5.6 9722 Radial Cabling

The following instructions assume the use of a System Industries FCC-compliant cabinet.

NOTE

There is no header for installing a terminator on this drive. The terminator consists of four DIP resistor packs mounted directly in front of the A-cable header. The drive is shipped with them already installed.

These micro drives are usually shipped pair-mounted in trays. Assume there are four drives in the cabinet. If the controller is in the same cabinet, no external cabling is required. Do step 1 below. If the controller is in a different cabinet do steps 2 and 3.

1. Run four internal A-cables from the controller RDI boards to CN1 on each drive and four internal B-cables to CN2 on each drive. Be sure the terminators are in place.
2. Route four internal A-cables and four internal B-cables from the controller RDI boards to the transition panel bulkhead connectors. Route four pairs of external A- and B-cables from the controller cabinet transition panel to the drive cabinet. Terminate the cable shields at the transition panel, and connect the cables to the 60- and 26-pin bulkhead connectors in the panel assembly.
3. Run internal A- and B-cables from the panel to CN1 and CN2, respectively, on each drive. Be sure the terminators are in place.

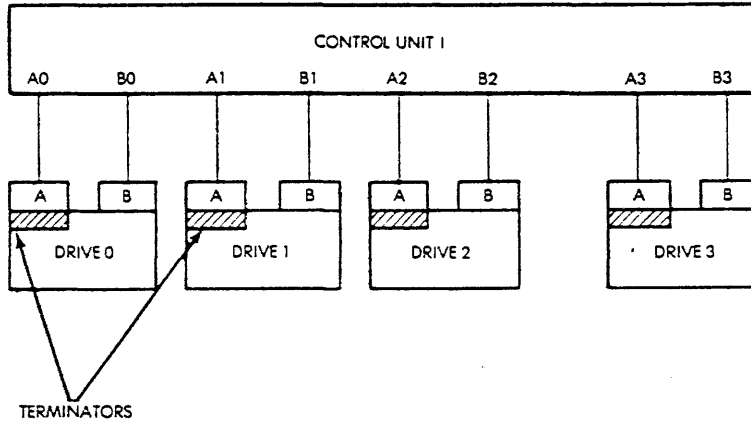

Figure 5-8. 9722 Block Diagram, Radial Cabling, Single Channel

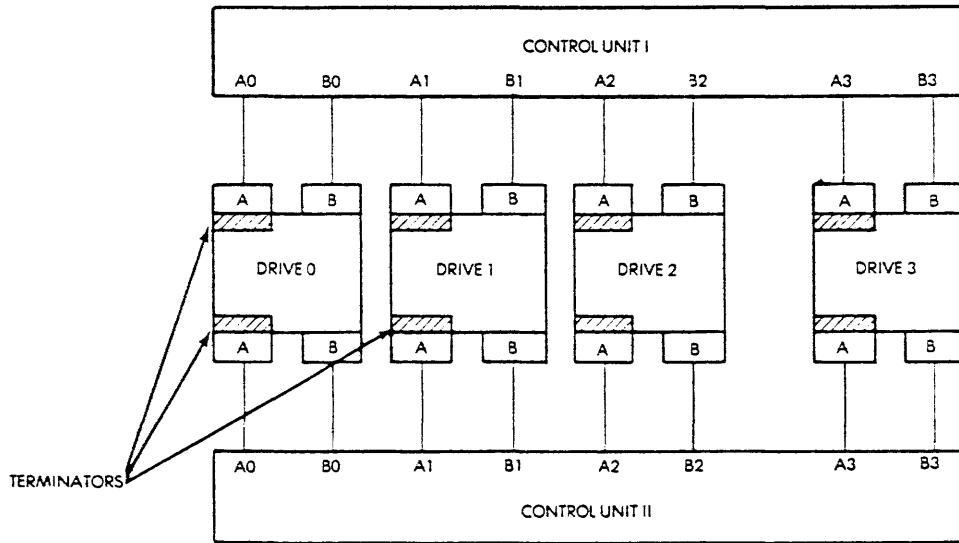

Figure 5-9. 9722 Block Diagram, Radial Cabling, Dual Channel

In a dual channel configuration attach the B-cable from controller II to CN22 on the dual-channel board, which is normally mounted on top of the power supply. Connect an A-cable from controller II to CN21 on the dual-channel board. Be sure the terminators are installed on each drive. (See Appendix C for detailed installation and cabling instructions for dual channel mode.)

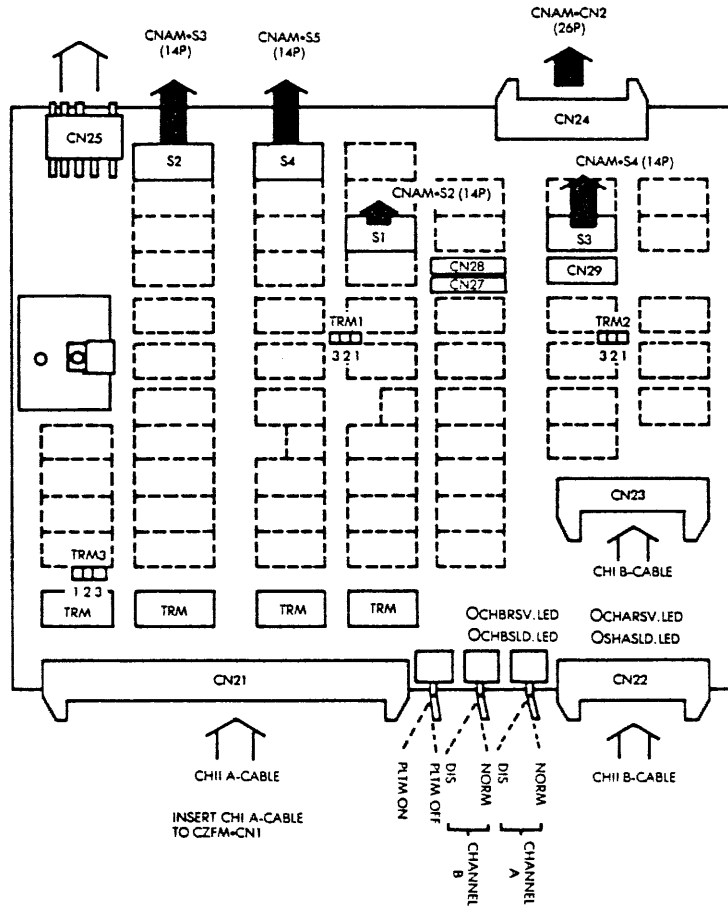

Figure 5-10. 9722 Dual Channel Interface PCB

5.7 9722 Daisy-chain Cabling

The following instructions assume the use of a System Industries FCC-compliant cabinet.

Although the block diagrams suggest that the drives are physically daisy-chained by a common A-cable, electrically the A-cable is functioning as a flexible bus. This means that a drive, or drives, can be taken offline without affecting the other drives in the chain.

There is no second A-cable header on the drive as there is on other drive models. Therefore the A-cable for an 9722 drive is different from the typical A-cable. It has female headers (insulation displacement connectors) distributed along it at intervals determined by the arrangement of the drives or other devices within the cabinet.

NOTE

There is no header for installing a terminator on this drive. The terminator consists of four resistor packs mounted directly in front of the A-cable header. The drive is shipped with them already installed.

Prior to cabling remove the resistor packs (terminator), using an IC extractor from all drives but the last drive in the chain.

1. Run the internal daisy-chain A-cable assembly from the controller and seat the first installation displacement connector to CN1 on the drive interface card. Continue until all drives have been connected.
2. Be sure the terminator (resistor packs) are in place on the last drive, unless there are drives in a second cabinet to be connected. In that case, run the A-cable to a 60-pin connector on the transition panel and run a shielded A-cable to the transition panel in the second cabinet. Run another internal daisy-chain A-cable assembly from the transition panel to the remaining drives in the chain. Terminate the last drive.
3. Run internal B-cable assemblies from the controller to CN2 on each drive. If there are additional drives in another cabinet to be connected, run as many B-cables as necessary from the controller to the transition panel. Run shielded B-cables to the transition panel in the second cabinet. Then run internal B-cables from the panel to each of the remaining drives in the chain.

NOTE

Be sure the resistor packs (terminators) are installed on the last drive in the chain.

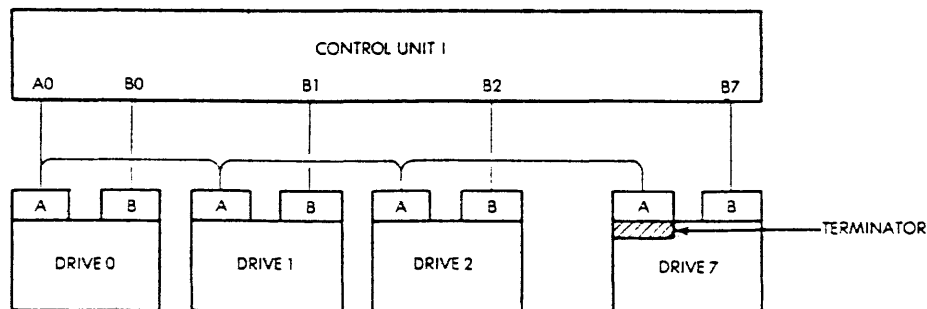

Figure 5-11. 9722 Block Diagram, Daisy-chain, Single Channel

For dual channel operation run an internal daisy-chain A-cable assembly from the second controller to CN21 on the dual-channel PCB on each drive. Run B-cables to CN22. If the drives in an additional cabinet are to be connected, the procedure is the same as in steps 2 and 3 above. (Refer to Appendix C for detailed installation and cabling instructions for the dual-channel option.)

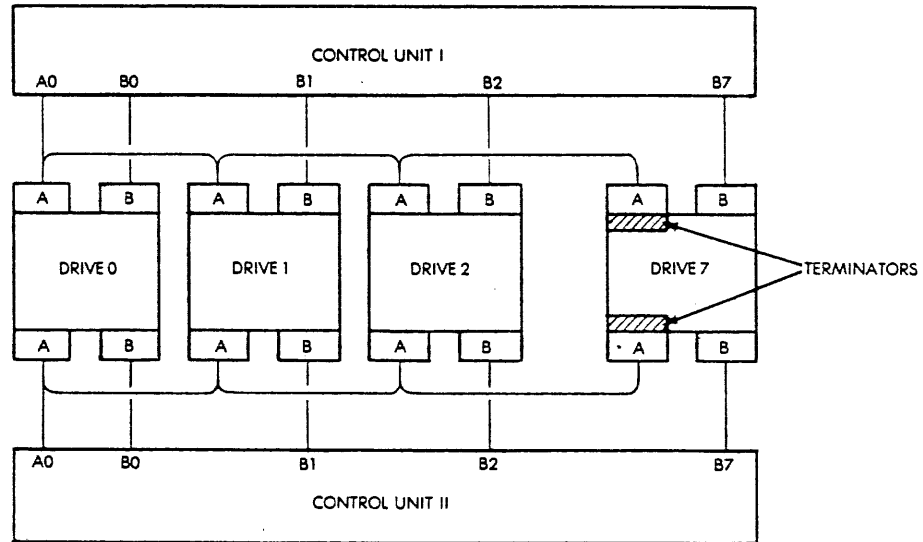

Figure 5-12. 9722 Block Diagram, Daisy-chain Cabling, Dual Channel

SECTION 6

SI 9733 DISK DRIVE

The 9733 is a 337 Mbyte FMD that is mounted in an SI FCC-compliant cabinet.

6.1 9733 Power and Grounding

This paragraph describes the power and grounding requirements of the 9733 FMD.

6.1.1 9733 Power Requirements

Each drive draws all power from its power supply unit, which is separate from the drive. Ideally, each drive's power supply has a dedicated AC line. However, in cases where there are more than six drives or six drives and a 9X00 controller in one 60-inch cabinet, power cabling could become a problem. That is because all AC power must be routed through an AC power distribution box to a power strip, and the power strip might have only six outlets.

Since 9733 drives can be pair mounted on trays in a standard 19-inch rack, the power cabling problem can be solved by jumpering the AC power on the power supply units. Thus only one AC line is required for two drives. All drive pairs can be connected to one AC line in this way.

CAUTION

In the above configuration, since the power supplies are jumpered in parallel, it is possible to power down one drive independently should one of the pair fail or need servicing. However, for safety reasons the AC power line serving both drives should be disconnected. If one of the jumpered pair is taken off-line for reasons not requiring physical contact with the drive or power supply interiors, the AC line can remain connected.

This drive does not need separate power supplies for 50 or 60 Hz operation because of the AC voltage group select switch on the power supply unit. The drive is powered by DC voltage (+5, +24, and -12 VDC).

In 60 Hz operation the power supply requires a 3-pin, 15-amp, 125-volt power connector (NEMA configuration 5-15P) The mating receptacle must be a NEMA configuration 5-15R, e.g., Hubble 5262.

6.1.2 9733 Power Supply Unit

The unit is mounted at the rear of the drive and is easily accessed by pulling the drive forward on its mounting rails. The following controls, connections, and indicators are on the power supply unit control panel:

- AC input lugs
- Main line switch/circuit breaker
- AC input voltage selection switch

- Frame and signal ground terminals
- Power-on indicator light
- Power and device alarm lights
- +5 VDC adjustment potentiometer

6.1.2.1 9733 AC Voltage Selection

There are two groups of AC voltages:

- 100 VAC at 50/60 Hz 115 VAC at 60 Hz 120 VAC at 60 Hz
- 220 VAC at 50 Hz 240 VAC at 50 Hz

The unit should come with the switch already set for the appropriate AC voltage group. If not, the setting will have to be changed.

The switch is covered by a plate that locks the switch and serves to prevent inadvertent change from one AC voltage group to another. Remove the plate and reset the switch. Turn the retainer plate over and replace it (Figure 6-1).

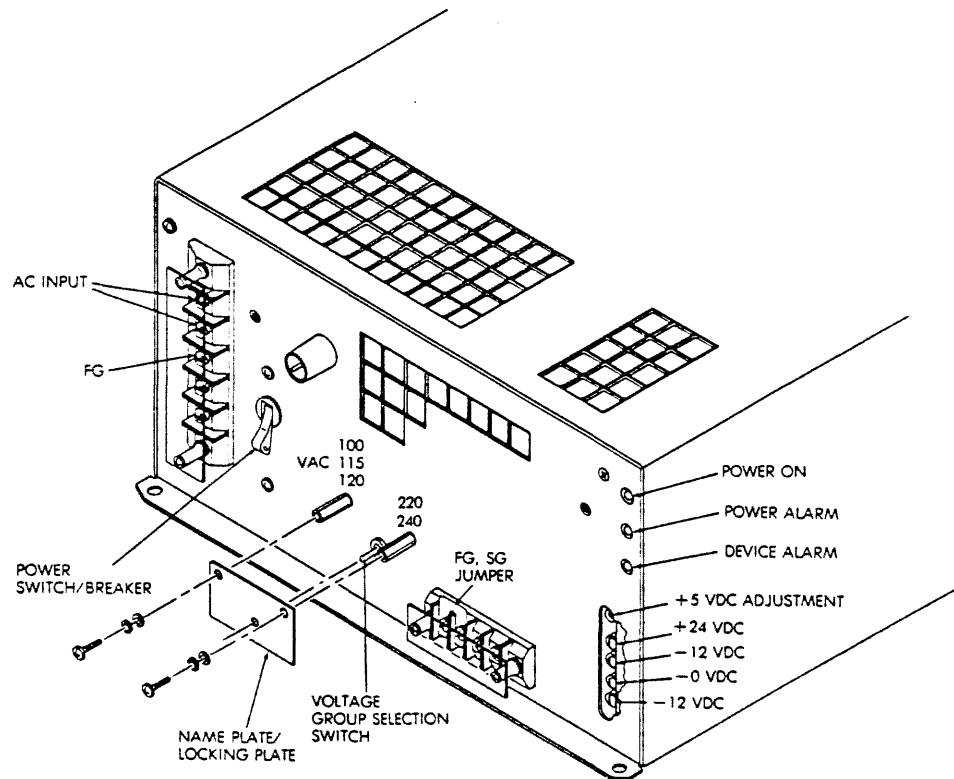

Figure 6-1. 9733 AC Voltage Selection Switch and Retainer Plate

Table 6-1. SI 9733 AC Voltage Specifications

VAC	RANGE (VAC)	FREQUENCY (HZ)	RANGE (HZ)
100	90—110	50/60	48.0—51.0/ 57.6—61.2
115	101—126	60	57.6—61.2
120	108—132	60	57.6—61.2
220	198—242	50	48.0—51.0
240	216—264	50	48.0—51.0

Table 6-2. SI 9733 DC Voltage Specifications

VOLTAGE	RANGE	CURRENT
+5 VDC	+4.85 to +5.15	4.8A
-12 VDC	-11.4 to -12.6	4.0A
+24 VDC	+21.6 to +26.4	4.2A

Table 6-3. SI 9733 Maximum Current Requirements

VAC	HZ	OPERATING CURRENT (AMPS)
100	50/60	3.5
115	50/60	3.3
120	60	3.2
220	50	1.8
240	50	1.7

6.1.2.2 9733 Power/Device Alarm Indicators

If the power alarm indicator light goes on, any of the following could have occurred:

- +5 VDC over current - over voltage - no voltage
- -12 VDC over current - no voltage
- +24 VDC over current - no voltage
- Overheating within the power supply
- AC output to the fan: over current

The device alarm lamp going on indicates that the thermal switch on the drive fan unit has closed (Figure 6-1).

6.1.3 9733 Grounding Specifications

The signal ground (SG) and frame ground (FG) are isolated in this drive. If it is necessary to connect the two, this can be done by using the SG grounding lug at the back of the drive. Normally, SG to FG connection is made by a jumper strap on the ground terminal strip of the power supply (Figure 6-2).

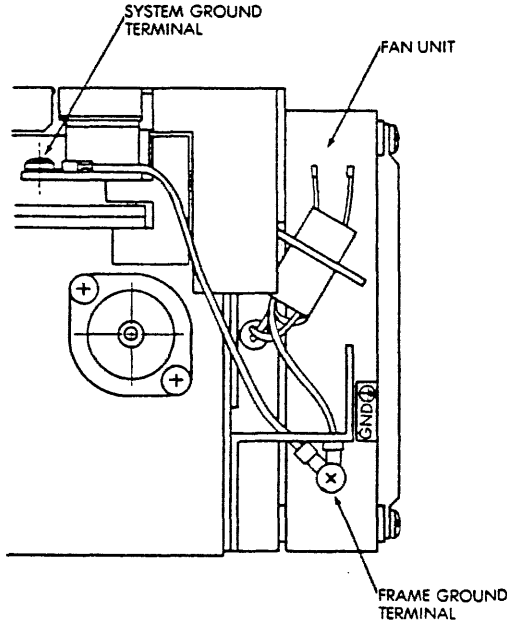

Figure 6-2. 9733 Signal Ground to Frame Ground Jumper

The drive must always be grounded, and the grounding should be done with insulated flat braided wire. Grounding schemes will vary depending on site and system configuration.

The controller should always be grounded to earth, thereby ensuring that the drive is grounded through the controller. Ideally, the drive(s), CPU, and controller would share a common AC branch circuit.

The recommended grounding schemes are shown in Figures 6-3 to 6-6.

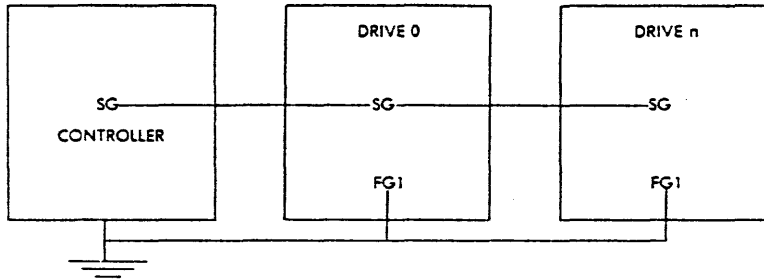

Figure 6-3. SI 9733 Grounding Method 1

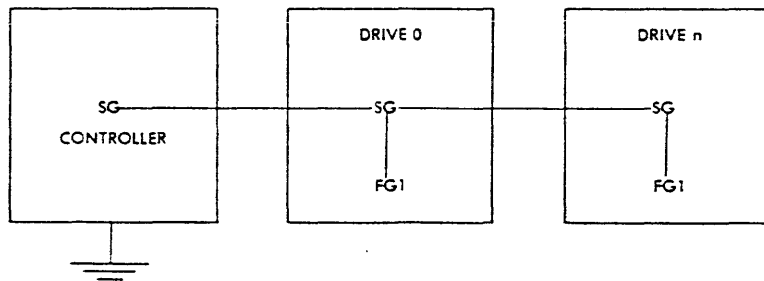

Figure 6-4. SI 9733 Grounding Method 2

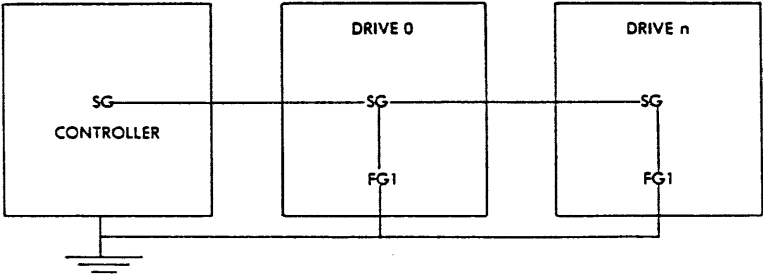

Figure 6-5. SI 9733 Grounding Method 3

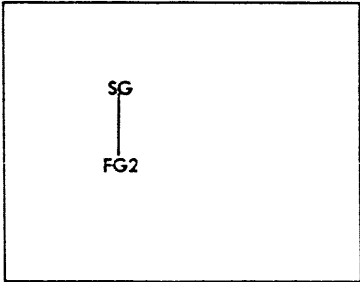

Figure 6-6. Grounding Scheme for Shipping

6.2 9733 Address Selection

Drive address, or unit number, is determined by setting switches one through three (S1—S3) on switch pack SW1 located at E3 on the drive's interface PCB (KGFM) (Figure 6-7). The settings are listed in Table 6-4.

Table 6-4. 9733 Address Selection Switch Settings

DEVICE ADDRESS	SWITCH SETTINGS		
	S1	S2	S3
0	OFF	OFF	OFF
1	ON	OFF	OFF
2	OFF	ON	OFF
3	ON	ON	OFF
4	OFF	OFF	ON
5	ON	OFF	ON
6	OFF	ON	ON
7	ON	ON	ON

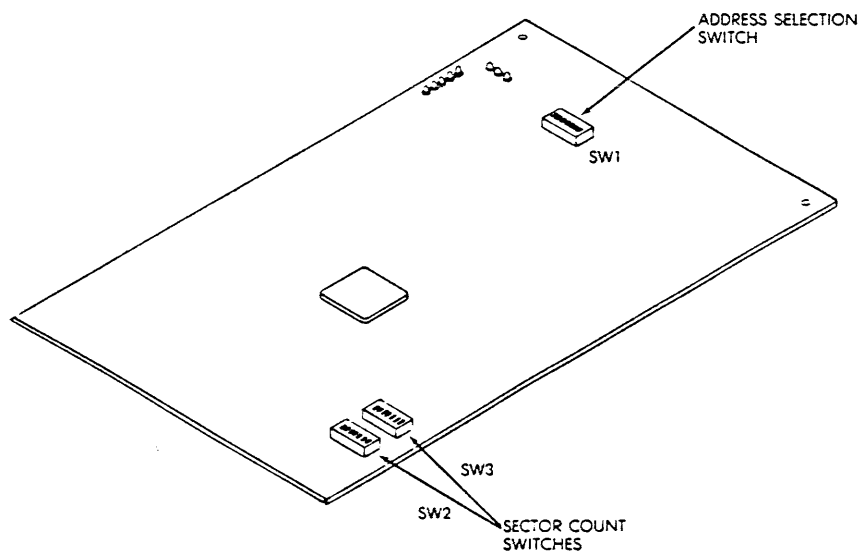

Figure 6-7. 9733 Interface PCB (KGFM)

6.3 9733 Sector Count

Two switch packs SW2 and SW3 at locations A25 and A23, respectively, on the drive interface PCB (KGFM) determine the sector count (Figure 6-7). With the 9900 controller this drive can only be configured for 67 sectors per track, regardless of whether or not bad block replacement is enabled. With QDA50E and SDA50E controllers the drive can only be configured for 60 sectors per track. The sector settings are shown in Table 6-5.

Table 6-5. 9733 Sector Count Settings

67 SECTORS				60 SECTORS				64 SECTORS			
SW2		SW3		SW2		SW3		SW2		SW3	
SWITCH#	SETTING	SWITCH#	SETTING	SWITCH#	SETTING	SWITCH#	SETTING	SWITCH#	SETTING	SWITCH#	SETTING
1	ON	1	OFF	1	OFF	1	OFF	1	ON	1	OFF
2	OFF	2	ON	2	OFF	2	ON	2	ON	2	ON
3	OFF	3	OFF	3	ON	3	OFF	3	ON	3	OFF
4	OFF	4	OFF	4	OFF	4	OFF	4	ON	4	OFF
5	ON	5	OFF	5	ON	5	OFF	5	ON	5	OFF
6	ON	6	OFF	6	OFF	6	OFF	6	ON	6	OFF
7	OFF	7	OFF	7	ON	7	OFF	7	OFF	7	OFF

6.4 9733 Drive Index and Sector Signals

This drive has one configuration: A-cable gated and B-cable continuous. No modifications can be made.

6.5 9733 Radial Cabling

The following instructions assume the use of a System Industries FCC-compliant cabinet.

NOTE

There is no header for installing a terminator on this drive. The terminator consists of four removable DIP resistor packs mounted directly in front of the A-cable header. The drive is shipped with them already installed.

The micro drives are usually shipped pair-mounted in trays. Assume there are four drives in the cabinet. If the controller is in the same cabinet, no external cabling is required. Do step 1 below. If the controller is in a different cabinet do steps 2-3.

- 1. Run four internal A-cables from the controller RDI boards to CN1 on each drive and four internal B-cables to CN2 on each drive. Be sure the terminators are in place.
- 2. Route four internal A-cables and four internal B-cables from the controller RDI boards to the transition panel bulkhead connectors. Route four pairs of external A- and B-cables

from the controller cabinet transition panel to the drive cabinet. Terminate the cable shields at the transition panel, and connect the cables to the 60- and 26-pin bulkhead connectors in the panel assembly.

3. Run internal A- and B-cables from the panel to CN1 and CN2, respectively, on each drive. Be sure the terminators are in place.

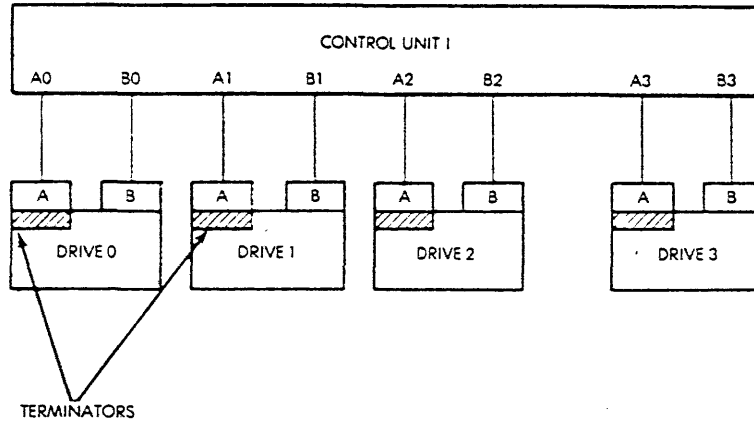

Figure 6-8. 9733 Radial Cabling, Single Channel

In a dual channel configuration attach the B-cable from controller II to CN22 on the dual channel board, which is normally mounted on top of the power supply. Connect an A-cable from controller II to CN21 on the dual channel board. Be sure the terminators are installed on each drive. (See Appendix C for detailed installation and cabling instructions for dual channel mode.)

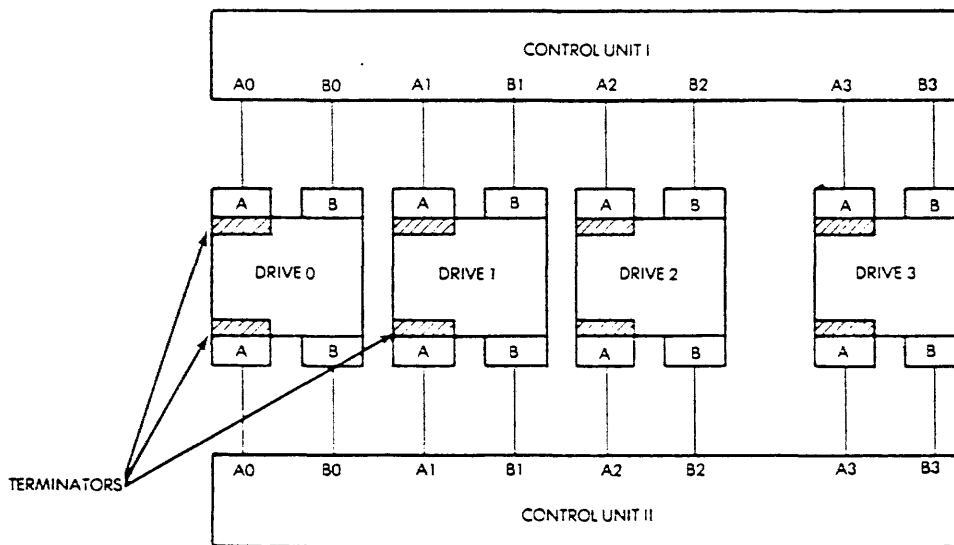

Figure 6-9. 9733 Radial Cabling, Dual Channel

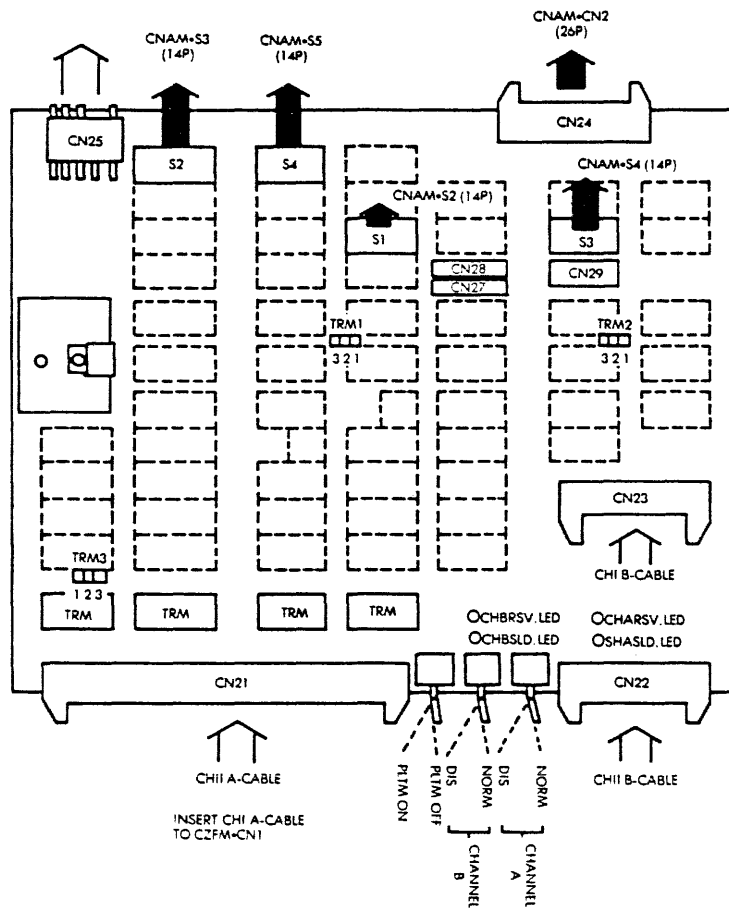

Figure 6-10. Dual Channel Interface PCB

6.6 9733 Daisy-chain Cabling

The following instructions assume the use of a System Industries FCC-compliant cabinet.

Although the block diagrams suggest that the drives are physically daisy-chained by a common A-cable, electrically the A-cable is functioning as a flexible bus (Figures 6-11 and 6-12). This means that a drive, or drives, can be taken off line without affecting the other drives in the chain.

There is no second A-cable header on the drive as there is on other drive models. Therefore the A-cable for a 9733 drive is different from the typical A-cable. It has female headers (insulation displacement connectors) distributed along it at intervals determined by the arrangement of the drives or other devices within the cabinet.

NOTE

There is no header for installing a terminator on this drive. The terminator consists of four resistor packs mounted directly in front of the A-cable header. The drive is shipped with them already installed.

Prior to cabling remove the resistor packs (terminator), using an IC extractor, from all drives but the last drive in the chain.

1. Run the internal daisy-chain A-cable assembly from the controller and seat the first installation displacement connector to CN1 on the drive interface card. Continue until all drives have been connected.
2. Be sure the terminator (resistor packs) are in place on the last drive, unless there are drives in a second cabinet to be connected. In that case, run the A-cable to a 60-pin connector on the transition panel and run a shielded A-cable to the transition panel in the second cabinet. Run another internal daisy-chain A-cable assembly from the transition panel to the remaining drives in the chain. Terminate the last drive.
3. Run internal B-cable assemblies from the controller to CN2 on each drive. If there are additional drives in another cabinet to be connected, run as many B-cables as necessary from the controller to the transition panel. Run shielded B-cables to the transition panel in the second cabinet. Then run internal B-cables from the panel to each of the remaining drives in the chain.

NOTE

Be sure the resistor packs (terminator) are installed on the last drive in the chain.

For dual channel operation run an internal daisy-chain A-cable assembly from the second controller to CN21 on the dual channel PCB on each drive. Run B-cables to CN22. If drives in an additional cabinet are to be connected, the procedure is the same as in steps 2 and 3 above. (Refer to Appendix C for detailed installation and cabling instructions for the dual channel option.)

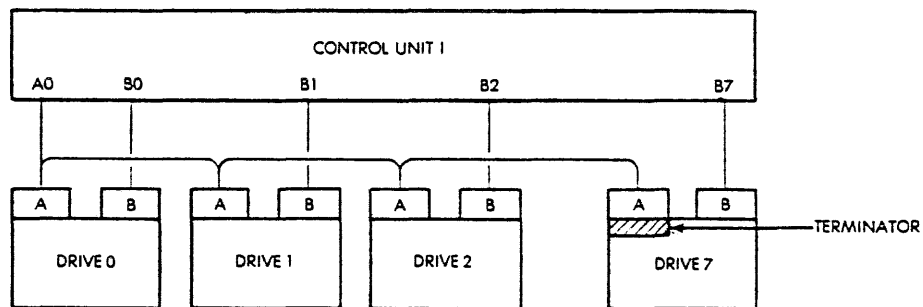

Figure 6-11. 9733 Block Diagram, Daisy-chain Cabling, Single Channel

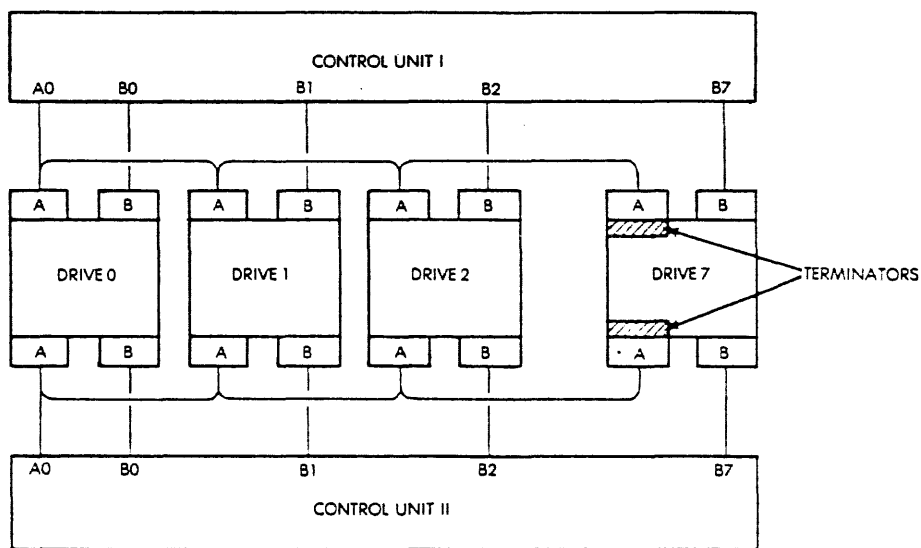

Figure 6-12. 9733 Block Diagram, Daisy-chain Cabling, Dual Channel

SECTION 7 SI 9798 DISK DRIVE

The SI 9798 is a 671 Mbyte fixed media disk drive to be rack mounted in an FCC-compliant cabinet.

7.1 9798 Power Requirements

The site must provide an AC power source for each drive.

The SI 9798 draws all power from its own power supply unit, which is connected to the site AC power.

Sixty-Hertz power supply units are supplied with a 3-pin, 15-amp, 125-volt power connector (NEMA configuration 5-15P). The mating receptacle must be NEMA configuration 5-15R; e.g., Hubbell 5262.

Fifty-Hertz power units are not supplied with a power connector.

The AC and DC voltages and maximum current requirements are listed in Tables 7-1, 7-2, and 7-3.

Table 7-1. SI 9798 Voltage Requirements

VAC	RANGE (VAC)	FREQUENCY (HZ)	RANGE (HZ)
100	90—110	60	57.0—61.0
115	104—132	60	57.6—61.2
100	90—110	50	49.5—51.5
220	195—242	50	49.0—50.5
240	220—264	50	49.0—50.5
100*	90—132	50	49.0—50.5

*Fan Motor

Table 7-2. SI 9798 AC Power Requirements

MODEL	RANGE (VAC)	FREQUENCY	RUN CURRENT	START CURRENT
60 Hertz	90—110	58.2—60.6	4.1A Nominal	9.6A Nominal
	104—132	60 Hz = 1%	4.3A Nominal	10.4A Nominal
50 Hertz	90—110	48.5—50.5	4.1A Nominal	9.6A Nominal
	193—242	49.0—50.5	1.8A Nominal	4.5A Nominal
	213—264	49.0—50.5	1.8A Nominal	4.5A Nominal

Table 7-3. SI 9798 DC Voltage/Current Requirements

VOLTAGE	LOAD CURRENT BASIC UNIT
4.75 to 5.25	4.2A max
11.4 to 12.6	0.43A max
-11.4 to -12.6	2.9A max
19.2 to 32.8	3.8A max

The power supply unit is connected to the SI 9798 by three cable assemblies supplied with the drive. The AC cable supplies AC power to drive the spindle motor, brake, and the blower motor. The DC cable and the attached power control connector supply DC power to the logic and analog circuits.

The procedure for connecting the drive to the power supply unit and selecting the AC input voltage is as follows:

The 60 Hertz power supply operates at 100 or 115 VAC, and the 50 Hertz operates at 220 or 240 VAC.

1. Selecting input AC voltage:

- a. Remove the power supply cover. It is held in place with four screws on each side on the bottom and two screws on the top.
- b. On the right side of the transformer there is a small terminal strip labeled INPUT. A white wire that is fastened to the terminal strip by a screw can be positioned in one of two locations labeled AC120V and AC100V (see Figure 7-1).

NOTE

A label on top of the power supply unit indicates which voltage was set at the factory.

- c. The procedure for selecting 240VAC/220VAC on the 50 Hertz version is the same.

2. Selecting +24 DC Voltage:

Both the 60 and 50 Hertz power supply units have one output which is switch selectable, either +24 VDC or -32 VDC. The 60 Hertz drive unit requires +24 VDC. Confirm that the switch on the rear of the power supply unit is set for +24V (see Figure 7-2).

3. Power Cable Connection:

The SI 9798 has three power cable connectors. Connect the AC cable connector (PW1) to PW1 on the power supply unit. Connect the DC cable connector (PW2) to PW2 on the power supply unit. Connect the power control connector (CN1) to CN18 on the power supply unit (see Figures 7-3 and 7-4).

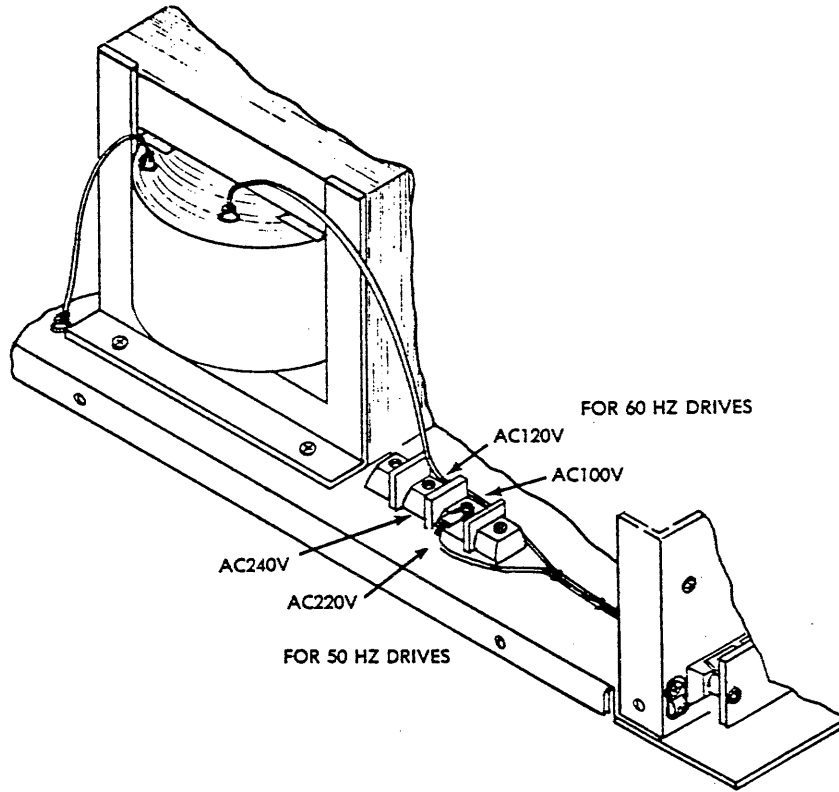

Figure 7-1. 9798 AC Voltage Selection

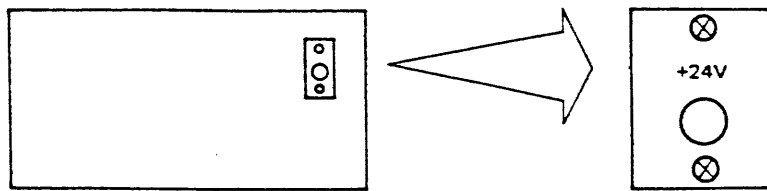

Figure 7-2. 9798 +24/-32 VDC Select Switch

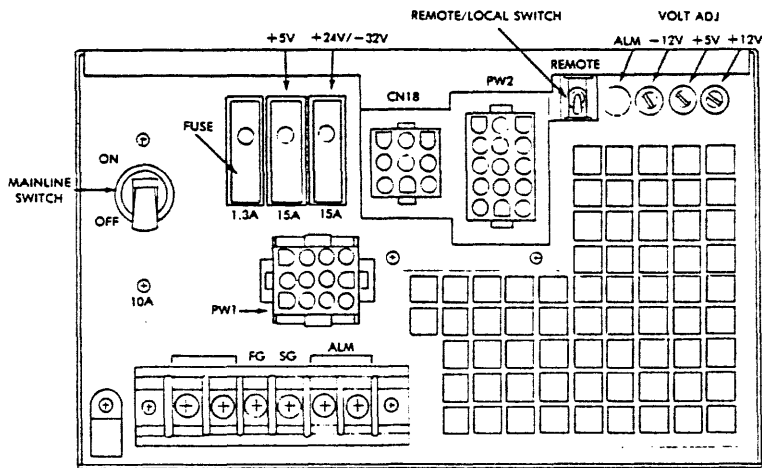

Figure 7-3. Power Cable Connection for 9798 (50 Hz)

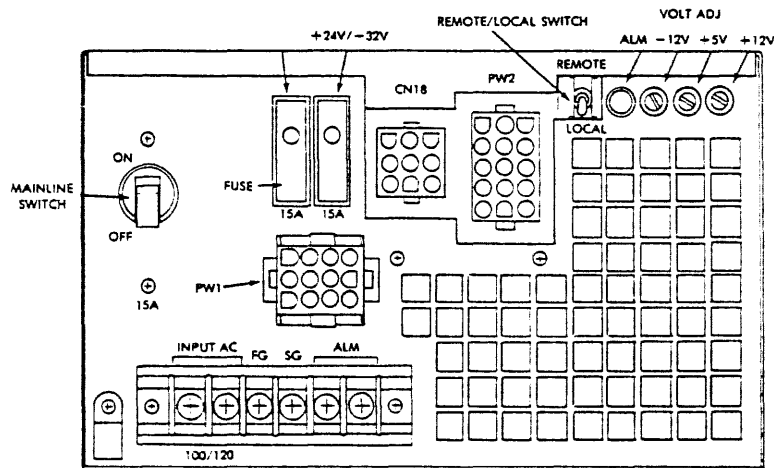

Figure 7-4. Power Cable Connection for 9798 (60 Hz)

7.2 9798 Grounding Requirements

There are three types of grounding. The first two depend on the requirements of the system. The third is mandatory.

1. **Drive Ground** The frame ground (FG) and the signal ground (SG) within the drive are separated. If the system requires FG and SG to be connected, attach the grounding cable between SG and the ground terminal (GND) (see Figure 7-5). If the system requires a ground between the system and the drive, attach the ground conductor to the GND terminal on the drive.
2. **Power Supply Unit Ground** FG and SG terminals are provided on the power supply unit (see Figures 7-3 and 7-4). System ground requirements and power distribution will determine whether or not FG and SG are to be connected.
3. **Daisy-chain Grounding Cable** An auxiliary grounding cable must be daisy-chained from the SG terminal on one drive to the SG terminal on the next drive and from the SG terminal of the last drive in the chain to the controller (see Figure 7-6).

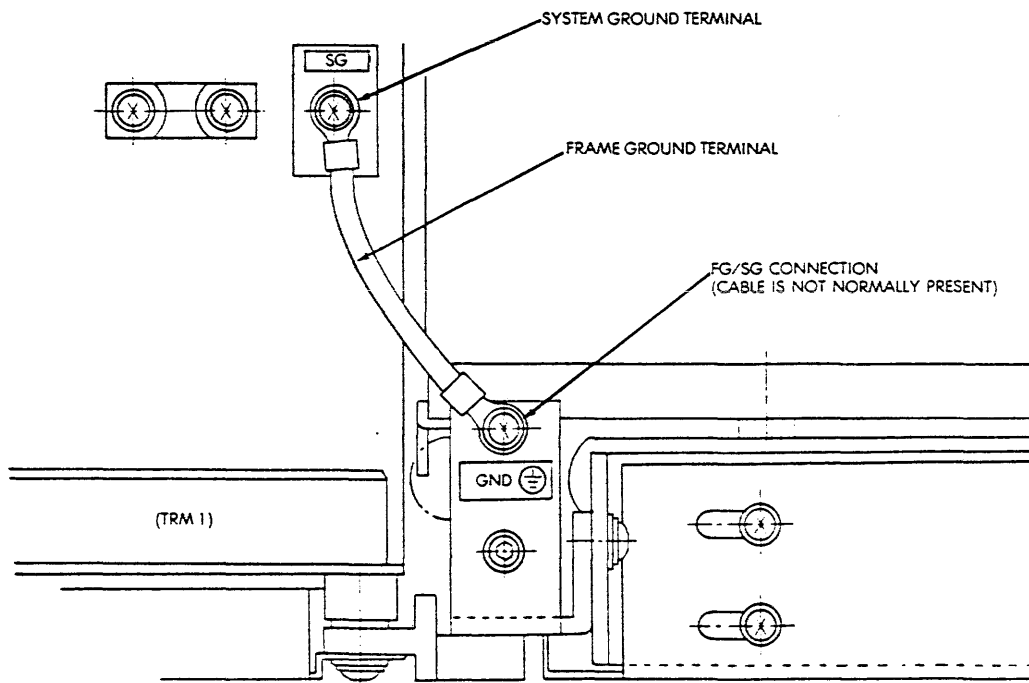

Figure 7-5. SI 9798 Drive Ground Terminal

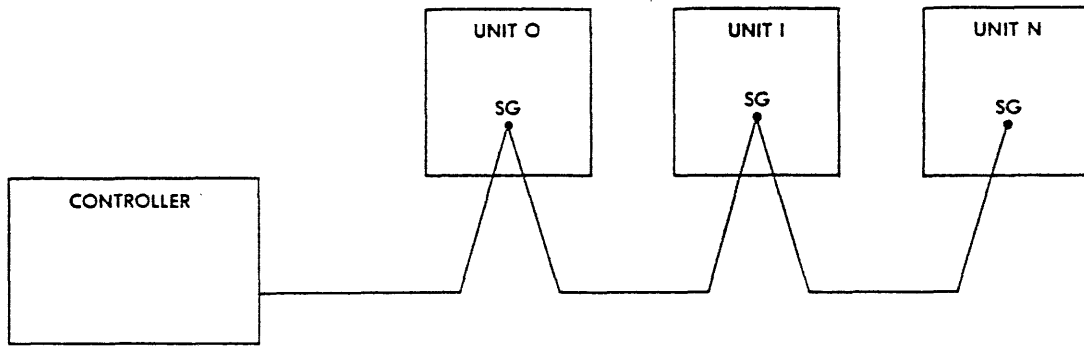

Figure 7-6. SI 9798 Auxiliary Ground Cable

7.3 9798 Address Selection

This paragraph describes the procedures to assign addresses (or unit numbers) to the disk drives supported by System Industries controllers. Refer to the applicable manufacturer's disk drive publication for instructions for accessing the logic chassis of the supported disk drive.

NOTE

Single-board controllers support a maximum of four drives. Therefore the addresses of the drives attached to a single-board controller will be in the range 0 through 3.

Unit addresses are selected for this drive with dip switch assembly SW1, switches SW1-1 through SW1-3. SW1 is located on the KGEM PCB assembly at J2 (see Figure 7-7).

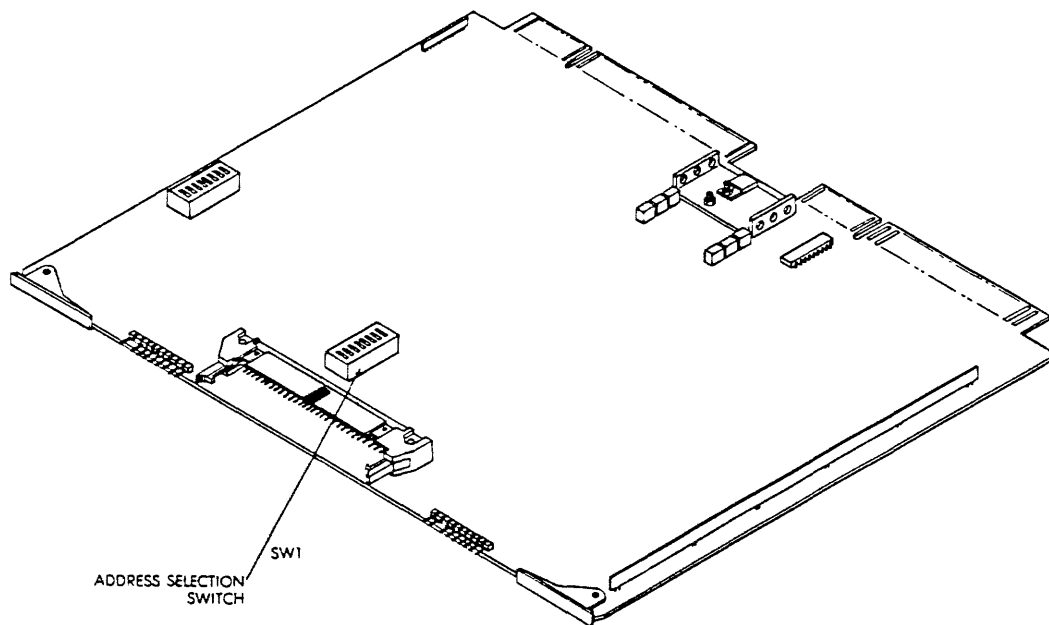

Figure 7-7. SI 9798 Address Switch Location on KGEM PCB

Table 7-4. SI 9798 Address Selection Switch Settings

DISK ADDRESS	SWITCH NUMBERS AND SETTINGS		
	SW1-1	SW1-2	SW1-3
0	OFF	OFF	OFF
1	ON	OFF	OFF
2	OFF	ON	OFF
3	ON	ON	OFF
4	OFF	OFF	ON
5	ON	OFF	ON
6	OFF	ON	ON
7	ON	ON	ON

ON = CLOSED
 OFF = OPEN

7.4 SI 9798 Sector Count

The sector count is set via switch packs SW1 at R10, and SW2 at P10, on the VOIM PCB assembly (Figure 7-8). Each switch pack is numbered 1-7. Switch settings are listed in Table 7-5. Only hard sector mode (1 to 128 sectors) is available. If the system is operating with a 9900 series controller, with or without bad block replacement (BBR) option enabled, the drive must be configured for 67 sectors per track.

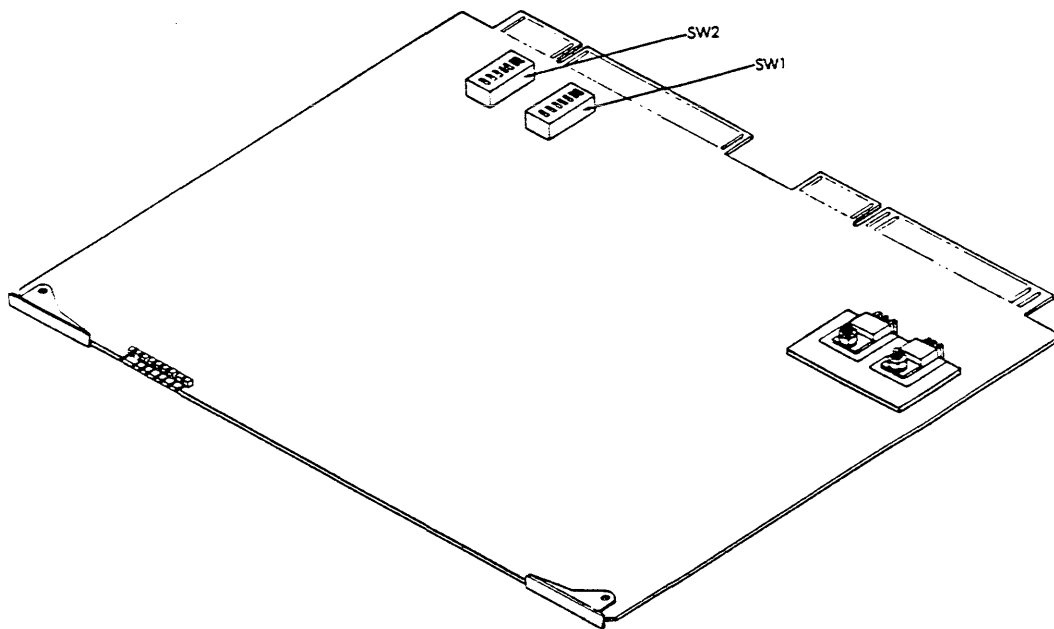

Figure 7-8. SI 9798 Sector Count Switch Locations on VOIM PCB

Table 7-5. SI 9798 Sector Count Switch Settings

SWITCH NUMBER	SECTORS	
	61	67*
SW1 (R10)		
1	OFF	ON
2	ON	OFF
3	ON	OFF
4	ON	OFF
5	OFF	ON
6	OFF	ON
7	ON	OFF
SW2 (P10)		
1	OFF	OFF
2	ON	ON
3	OFF	OFF
4	OFF	OFF
5	OFF	OFF
6	OFF	OFF
7	OFF	OFF

*BBR enabled

7.5 9798 Drive Index and Sector Signals

These drives have one configuration: A-cable gated and B-cable continuous. No modifications can be made.

7.6 9798 Radial Cabling

The following instructions assume the use of a System Industries FCC-compliant cabinet. If the controller and drives are in the same cabinet, no shielded drive cables are needed. Follow steps 1 and 2 below. If the controller is in another cabinet, follow steps 4-7.

1. Run an internal A-cable from the controller RDI board to connector OM2 on the disk drive.
2. Run an internal B-cable from the RDI board to OM3 on the disk drive.
3. Install a terminator at OM1 on each drive.
4. If the controller is in another cabinet, run four internal A- and four internal B-cables from the RDI board to the transition panel in the controller cabinet.
5. Run four pairs of shielded A- and B-cables from the transition panel to the transition panel of the drive cabinet. Terminate the shields and connect the cables to the appropriate connectors on the transition panel.

6. Run internal A- and B-cables from the transition panel assembly connector board to OM2 and OM3, respectively, on each drive.
7. Install terminators at OM1 on each drive.

For dual channel configurations repeat the above procedure connecting the A- and B-cables to OM2B and OM3B on the dual channel adapter board and installing terminators at OM1B.

Figure 7-9 illustrates single channel radial cabling.

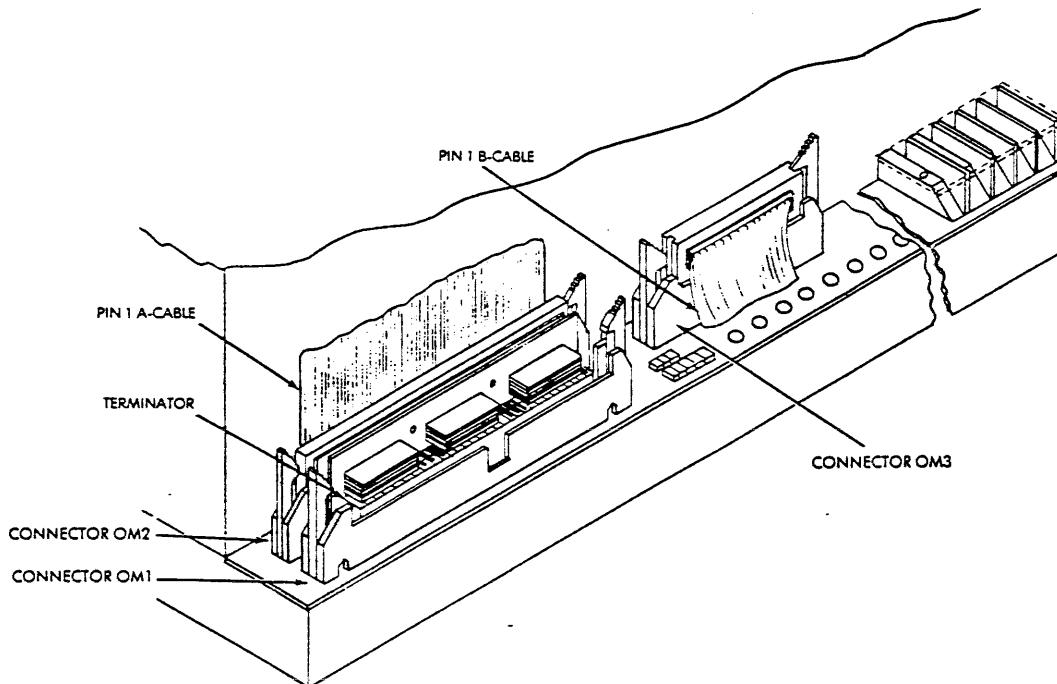

Figure 7-9. 9798 Radial Cabling, Single Channel

7.7 9798 Daisy-chain Cabling

The following instructions assume the use of a System Industries FCC-compliant cabinet. If the drives and controller are in the same cabinet, no shielded drive cables are needed. Follow steps 1-2. If the controller is in another cabinet, do steps 3-10.

1. Remove the terminators from OM1 on all but the last drive. Run an internal A-cable from the controller to OM2 on the first drive. Run another A-cable from OM1 on the first drive to OM2 on the next drive. Repeat until all drives are connected. Install a terminator at OM1 on the last drive.
2. Run B-cables from the controller to OM3 on each drive.
3. If the controller and possibly additional 9798s are in another cabinet, cable the drives as in steps 1-2, but do not terminate the last drive. Run an A-cable from OM1 to the transition panel assembly connector board.

4. Run as many B-cables from the controller as there are remaining drives to be connected in the other cabinet. Connect the B-cables from the controller to the transition panel.
5. Run a shielded A-cable from the transition panel in the controller cabinet to the transition panel in the cabinet housing the remaining drives. Be sure the cable shields are terminated at each cabinet. Connect the shielded A-cable pigtail to a 60-pin connector on the connector board.
6. Run an internal A-cable from the transition panel assembly connector board to OM2 on the first drive.
7. Run another A-cable from OM1 on the first drive to OM2 on the next. Repeat until all drives are connected. Install a terminator at OM1 on the last drive.
8. Run shielded B-cables from the controller cabinet to the other drive cabinet. Terminate the external cables at both cabinets.
9. Connect the pigtails of the shielded B-cables to the 26-pin connectors on the connector board.
10. Run internal B-cables from the connector board to OM3 on each drive.

For dual channel configurations repeat the above procedure connecting the A- and B-cables to OM1B, OM2B, and OM3B on the dual channel adapter board and installing a terminator at OM1B on the last drive.

Figure 7-10 illustrates single channel daisy-chain cabling for the 9798 disk drive.

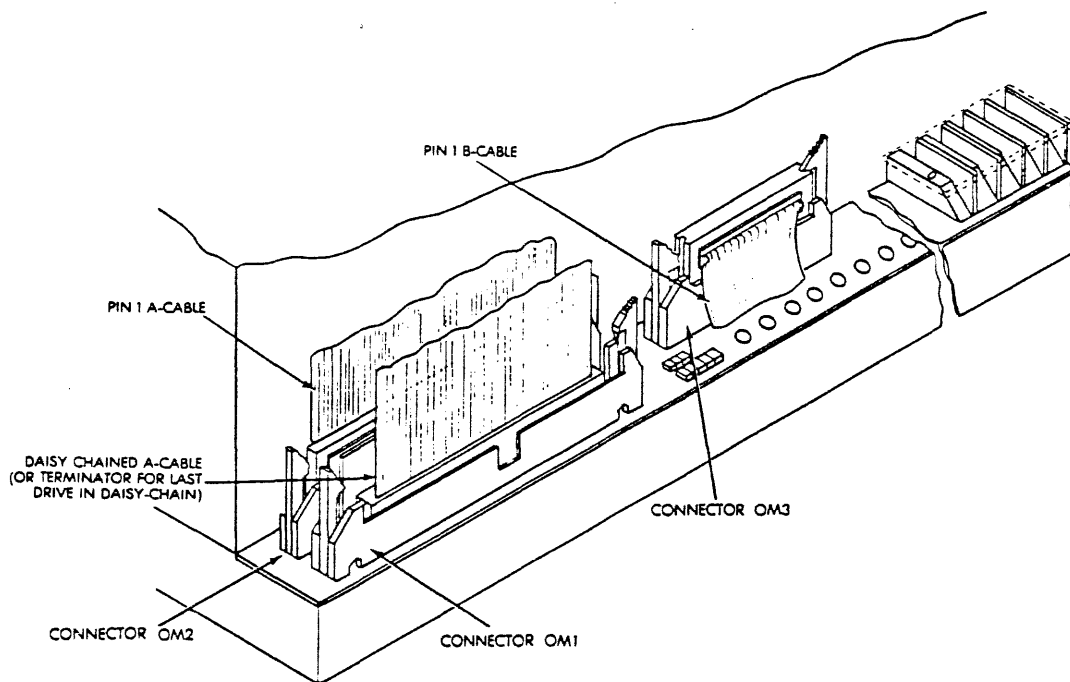

Figure 7-10. Daisy-chain Cabling, Single Channel

SECTION 8 SI 9761 DISK DRIVE

The SI 9761 is a 689 Mbyte FMD that is rack mounted in an SI FCC-compliant cabinet.

8.1 9761 Power Requirements

The site must provide an AC power source for each drive. The drive draws all power from its own power supply unit (an integral part of the drive), which is connected to the site AC power.

Sixty-Hertz power supply units are supplied with a 3-pin, 15-amp, 125-volt power connector (NEMA configuration 5-15R). The mating receptacle must be NEMA configuration 5-15P (e.g., Hubbell 5262).

Fifty-Hertz power supply units are not supplied with a power connector.

AC voltage requirements and maximum current requirements of the power supply unit are listed in Tables 8-1 and 8-2.

Table 8-1. 9761 Voltage Requirements

VAC	RANGE (VAC)	FREQUENCY (HZ)	RANGE (HZ)
100	90—110	50/60	±2
120	108—132	60	±2
200	180—220	50/60	±2
220	198—242	50	±2
240	216—264	50	±2

Table 8-2. 9761 Maximum Current Requirements

VAC	HZ	OPERATING CURRENT (AMPS)
100	50/60	6.0/5.7
120	60	4.6
200	50/60	3.1/3.0
220	50	2.9
240	50	2.6

8.1.1 AC Voltage Selection

At the upper right hand corner of the power supply (back of the drive) are two vertically aligned AC voltage power sockets for 100-120 (upper socket) and 200-240 (lower socket) VAC (Figure 8-1). They have a plastic cover, one end of which has an opening to permit the transition of the power connector CN69. The cover is held in place by two screws.

The AC voltage should have been correctly configured at the factory. If a change is required, disconnect CN69, remove the cover, invert it, and reinstall it to reconfigure for the required voltage. Reconnect CN69.

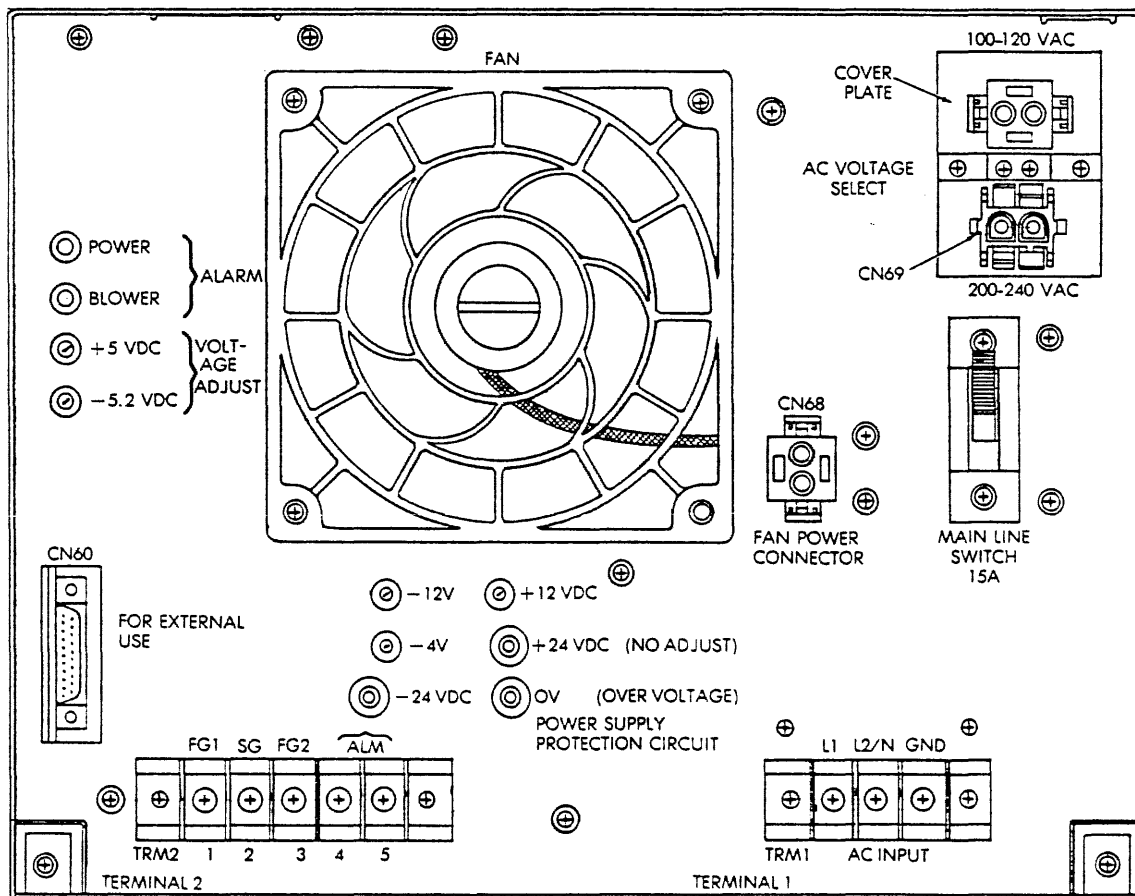

Figure 8-1. SI 9761 Power Supply Control Panel

8.2 9761 Grounding Requirements

The AC ground is located next to the AC inputs at the lower left hand corner of the power supply unit. It is connected to the chassis (Figure 8-1).

There three other grounding lugs at the lower left hand corner and are defined as follows:

- SG The signal (DC) ground. It is isolated from the AC ground within the drive.
- FG1 The frame (AC) ground. It is a direct short to the drive chassis.
- FG2 A high impedance AC ground connected to FG1 through a 510K ohm resistor. SG is connected to FG2 for shipment.

The drives should always be grounded. If cable lengths exceed ten feet or the drives are daisy-chained, grounding is mandatory. Grounding should be done with insulated flat braided wire.

Grounding methods vary depending upon the site and the system configuration. The following four methods of grounding are listed in order of preference.

1. Isolate FG and SG. Connect SG to controller signal ground. Connect FG1 to the controller chassis (AC ground).
2. Connect SG to FG1 and connect SG to controller signal ground.
3. Connect SG and FG1. Connect FG1 to the controller chassis (AC ground).

The controller should always be earth grounded to ensure that the drives are grounded through the controller. Optimally, the drives, controller, and CPU should have a common AC branch circuit.

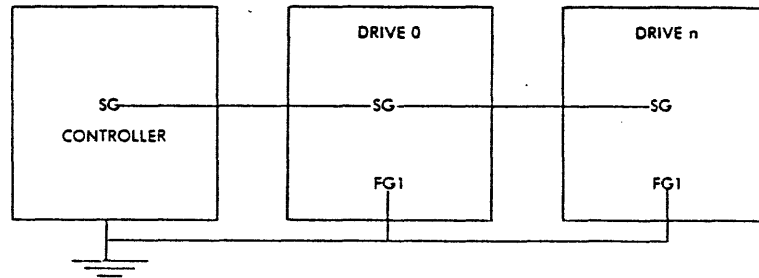

Figure 8-2. 9761 Grounding Method 1

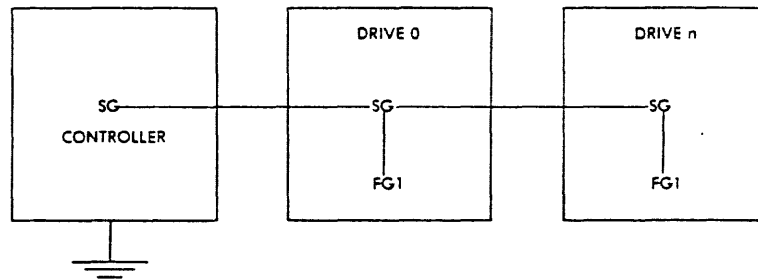

Figure 8-3. 9761 Grounding Method 2

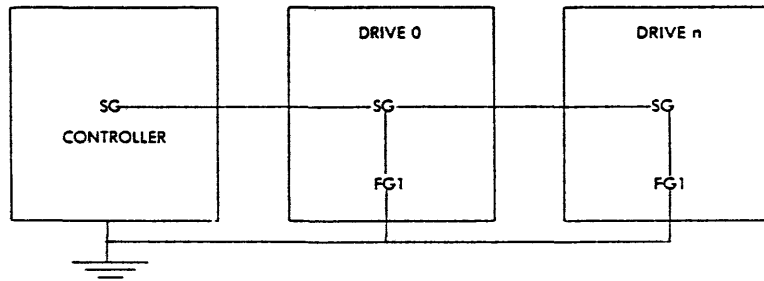

Figure 8-4. 9761 Grounding Method 3

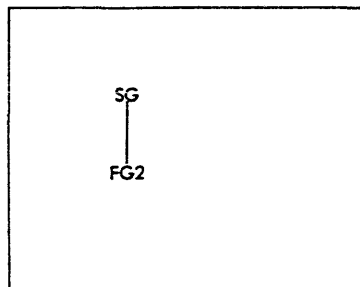

Figure 8-5. Grounding Scheme for Shipping

8.3 9761 Address Selection

The address selection switch pack is located on the drive's front display panel (Figure 8-6). Only switches 3, 4, and 5 set the address. Switch 1 is always OFF. Switch settings are shown in Table 8-3.

Table 8-3. 9761 Address Selection Switch Settings

DISK ADDRESS	SWITCH NUMBERS AND SETTINGS			
	SW1	SW2	SW3	SW4
0	OFF	OFF	OFF	OFF
1	OFF	OFF	OFF	ON
2	OFF	OFF	ON	OFF
3	OFF	OFF	ON	ON
4	OFF	ON	OFF	OFF
5	OFF	ON	OFF	ON
6	OFF	ON	ON	OFF
7	OFF	ON	ON	ON

ON = CLOSED
OFF = OPEN

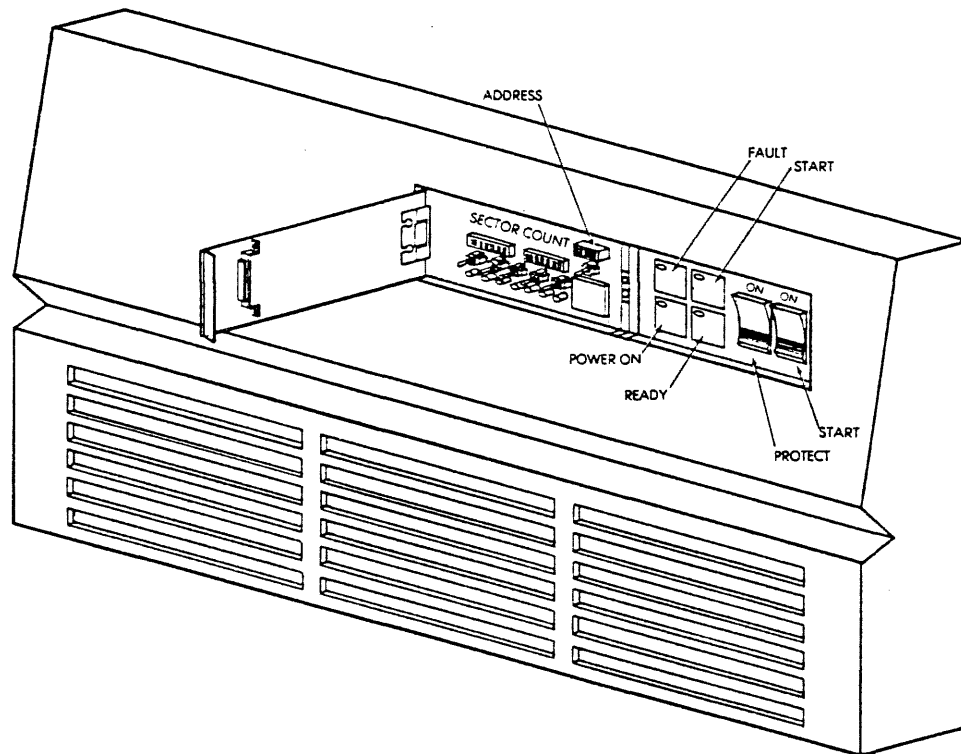

Figure 8-6. 9761 Front Panel

8.4 9761 Sector Count

The sector count switch banks (SWA and SWB) are located on the drive front panel (Figures 8-6 and 8-7). The switch packs are not labeled, but A is on the right, facing the front of the drive, and B is on the left. The switches are numbered 1-8 from left to right. When used with the 9900 controller, the drive can only be configured for 67 sectors/track. When used with SDA50 or QDA50 controllers, the drive must be configured for 60 sectors/track. The switch settings are listed in Table 8-4. Currently, these are the only supported configurations.

Table 8-4. 9761 Sector Count Switch Settings

67 SECTORS			60 SECTORS		
SWITCH NUMBER	SWB SETTING	SWA SETTING	SWITCH NUMBER	SWB SETTING	SWA SETTING
1	OFF	OFF	1	OFF	ON
2	OFF	ON	2	OFF	OFF
3	OFF	ON	3	OFF	ON
4	OFF	OFF	4	OFF	OFF
5	OFF	OFF	5	OFF	ON
6	OFF	OFF	6	OFF	OFF
7	ON	ON	7	ON	OFF
8	OFF	ON	8	OFF	ON

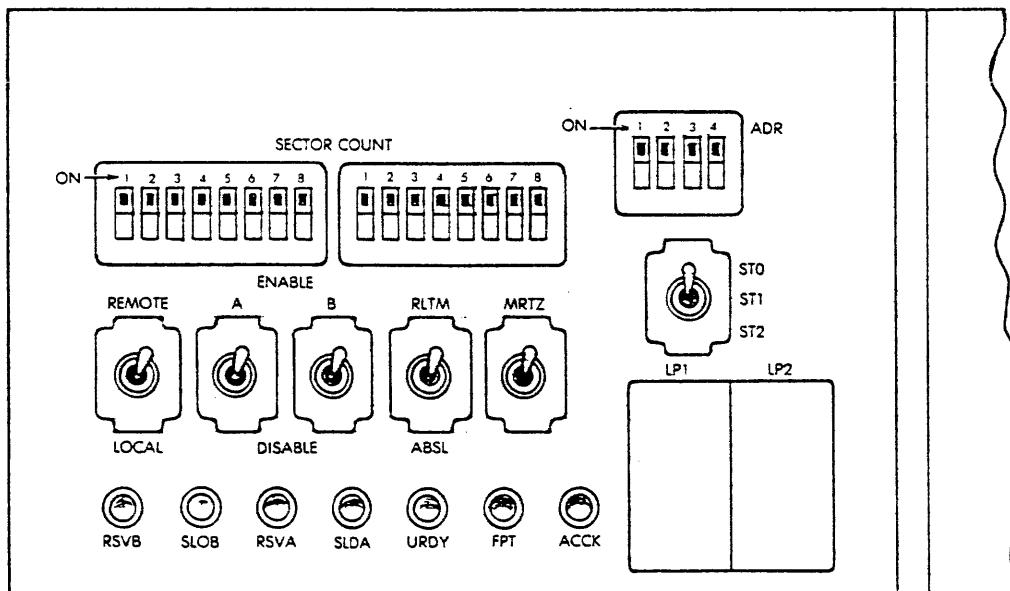

Figure 8-7. 9761 Switch Locations

8.5 9761 Drive Index and Sector Signals

Index and sector signals must be gated on the A-cable and continuous on the B-cable. No modifications can be made.

NOTE

Tags 4 and 5 are not used and must be disabled. Short out pins 3 and 4 at SH09 on the drive logic PCB.

8.6 9761 Radial Cabling

The following instructions assume the use of a System Industries FCC-compliant cabinet. If the drives and controller are in the same cabinet, no shielded cables are needed. Follow steps 1-3. If the controller is in another cabinet, follow steps 5-8.

1. Run an internal A-cable from the controller RDI board to connector CNP41 on the drive interface PCB.
2. Run an internal B-cable from the controller RDI board to connector CNP43 on the drive interface PCB.
3. Repeat steps 1-2 until all drives have been connected.
4. install terminators at CNP42 on each drive (Figure 8-8).
5. If the controller is in another cabinet, run internal A- and B-cables from the RDI board on the transition panel assembly.
6. Run shielded A- and B-cables from the transition panel to the drive cabinet. Terminate the external cables at both cabinets.
7. Plug the pigtails of the shielded A- and B-cables to the appropriate connectors on the transition panel connector board.
8. Run internal A- and B-cables from the connector board to CNP41 and CNP43, respectively, on each drive. Install a terminator at CNP42 on each drive.

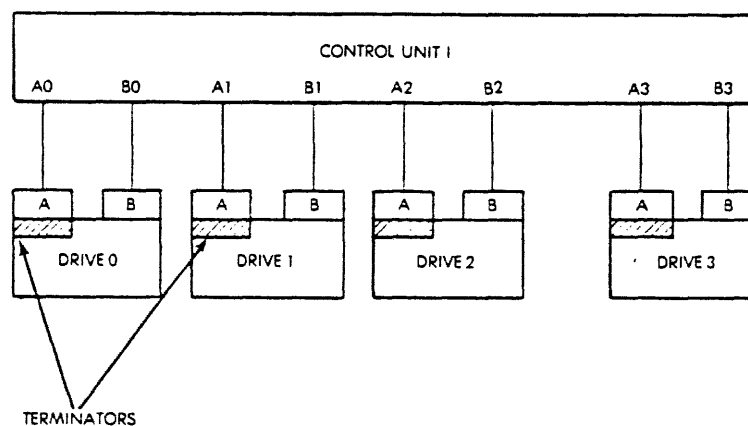

Figure 8-8. 9761 Radial Cabling, Single Channel

For dual channel configurations repeat the above procedures connecting the A- and B-cables from the second controller to CNP51 and CNP52, respectively, on the dual channel interface PCB. Install terminators at CNP52 on each drive.

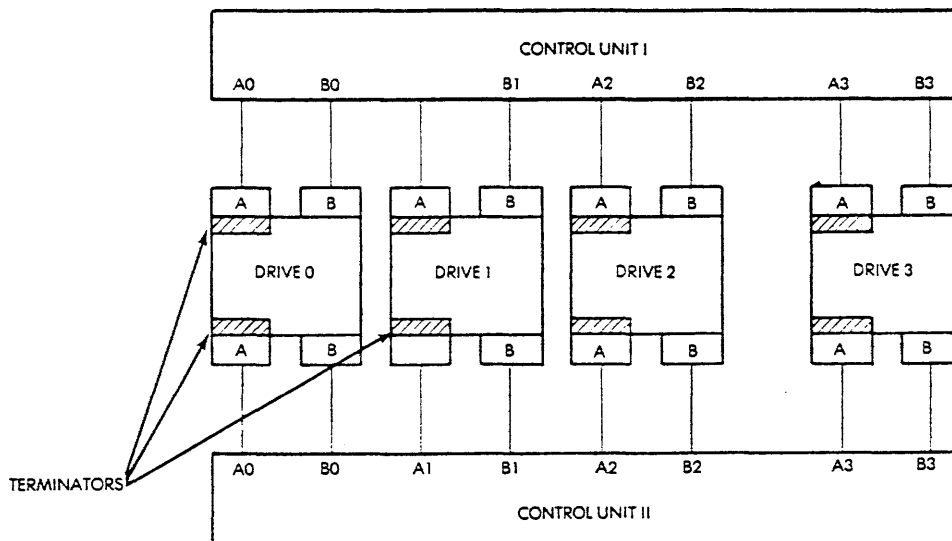

Figure 8-9. 9761 Radial Cabling, Dual Channel

8.7 Daisy-chain Cabling

The following instructions assume the use of a System Industries FCC-compliant cabinet. If the drives and controller are in the same cabinet, no external cables are needed. Follow steps 1-3. If the controller and possibly other 9761 drives are in a different cabinet, follow steps 4-10.

1. Run an internal A-cable from the controller to CNP41 on the on the drive interface PCB.
2. Run a second A-cable from CNP42 on the first drive to CNP41 on the second drive. Repeat this until all drives have been connected. Install a terminator in CNP42 on the last drive.
3. Run B-cables from the controller to CNP43 on each drive.
4. If the controller and additional drives are in another cabinet, do not terminate the last drive in the controller cabinet. Run the A-cable from CNP42 on the last drive to a 60-pin connector on the transition panel connector board. From the controller run as many B-cables as are needed for the drives in the other cabinet to the connector board and plug them into the 26-pin connectors.

5. Run a shielded A-cable from the controller cabinet to the other drive cabinet. Terminate the external cables at both cabinets. Plug the pigtails of the shielded A-cable into the 60-pin connectors on the connector boards of each cabinet.
6. Run an internal A-cable from connector board to CNP41 on the first drive. Run another A-cable from CNP42 to CNP41 on the next drive. Repeat this until the remaining drives have been connected. Terminate the last drive at CNP42 (Figure 8-10).
7. Run the shielded B-cables from the controller cabinet to the transition panel assembly in the other cabinet. Terminate the cables at both cabinets.
8. Plug the pigtails of the shielded B-cables into the 26-pin connectors on the connector boards of each cabinet.
9. Run internal B-cables from the connector board to CNP43 on each of the remaining drives.
10. Be sure there are no unsealed ports on any of the transition panels.

For dual channel configurations repeat the above procedure connecting the A- and B-cables, via the transition panel assembly, it necessary, to CNP51, CNP52, and CNP53 on the dual channel interface PCB. A terminator goes in CNP52 on the last drive in the chain (Figure 8-11).

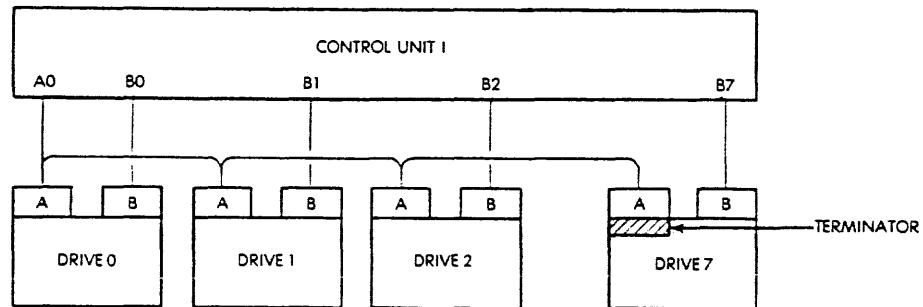

Figure 8-10. Daisy-chain Cabling, Single Channel

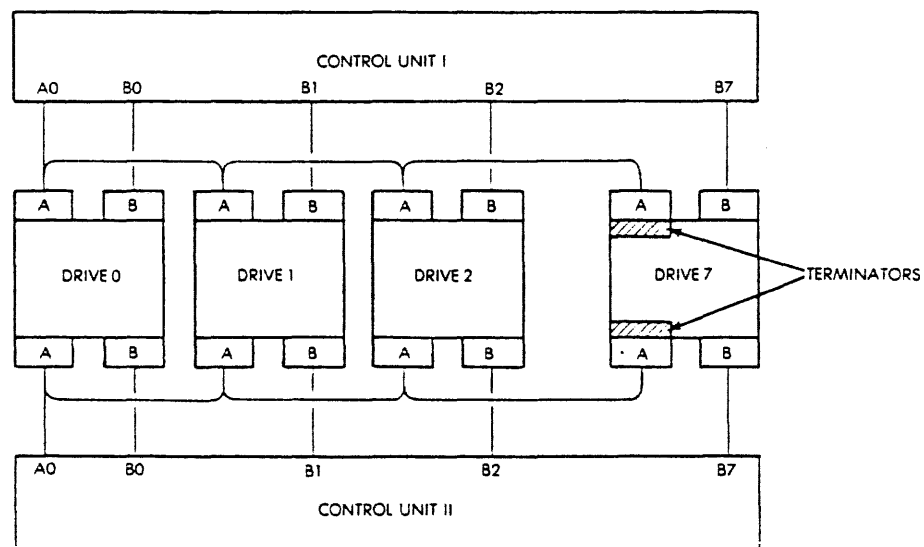

Figure 8-11. Daisy-chain Cabling, Dual Channel

SECTION 9 SI 9762 DISK DRIVE

The SI 9762 is an 80 Mbyte removable media disk drive (RMD) in a pedestal cabinet.

9.1 9762 Power Requirements

The site must have an AC power source for each drive. Each drive connects to the power source by a six-foot cord provided with the drive.

Sixty-Hertz drives are supplied with a 3-pin, 15-amp, 125-volt power connector (NEMA configuration 5-15P). The mating receptacle must be NEMA configuration 5-15R (e.g., Hubbell 5262).

Fifty-Hertz drives are not supplied with a power connector.

The voltage and maximum current requirements are listed in Tables 9-1 and 9-2.

Table 9-1. SI 9762 Voltage Requirements

VAC	RANGE (VAC)	FREQUENCY (HZ)	RANGE (HZ)
100	90—110	60	59.0—60.5
120	102—128	60	59.0—60.5
220	195—235	50	49.0—50.5
240	213—257	50	49.0—50.5

Table 9-2. SI 9762 Maximum Current Requirements

VAC/HZ	CURRENT IN AMPS	
	OPERATING*	STANDBY**
100/60	8.2	1.5
120/60	8.2	1.5
220/50	4.2	1.4
240/50	5.0	1.5

*Carriage and disks in motion

**Disks not rotating

9.2 9762 Grounding Requirements

The site AC power source must provide proper grounding. Two types of grounding are required: safety ground and system ground.

A safety ground is provided by an insulated green (or green with yellow stripe) grounding conductor in the AC power cord. This wire is connected to the drive frame and is grounded to earth through the AC circuit supplying power to the drive.

Adequate system grounding provides additional connections to earth ground. System grounding reduces radio frequency interference (RFI) radiation and can be provided by any of the following methods (listed in preferred order):

Grounded Floor Grid The drives and the controller are connected to a grounded floor grid to ensure a constant ground potential at all connection points. The grid is connected directly to earth ground (see Figure 9-1).

Ungrounded Floor Grid The drives and the controller are connected to an ungrounded floor grid. To ground the grid and the drives, the controller is connected to earth ground (see Figure 9-1).

Daisy-chain The drive ground terminals are connected in a daisy chain from drive to drive and then to the controller. The controller is connected to earth ground. Daisy-chain grounding requires that the controller and drives have common AC and DC ground (see Figure 9-2).

The system ground is attached to the drive by connecting one end of the groundstrap to the ground lug on the rear of the drive. The other end of the groundstrap is then connected either to the floor grid or to the next drive in the chain, depending on which system grounding method was selected (see Figure 9-3).

NOTE

The SI 9762 ground scheme connects the AC and DC ground. There is no provision for grounding AC and DC separately.

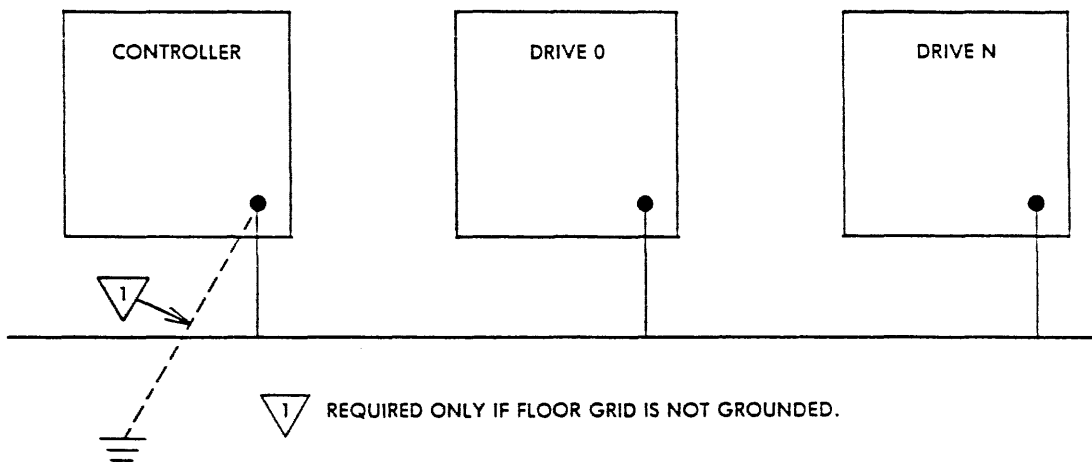

Figure 9-1. SI 9762 Floor Grid System Grounding

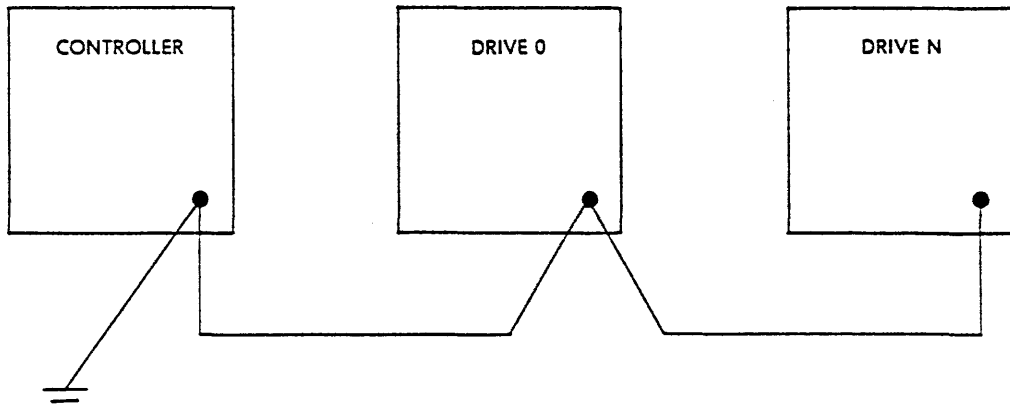

Figure 9-2. SI 9762 Daisy-chain System Grounding

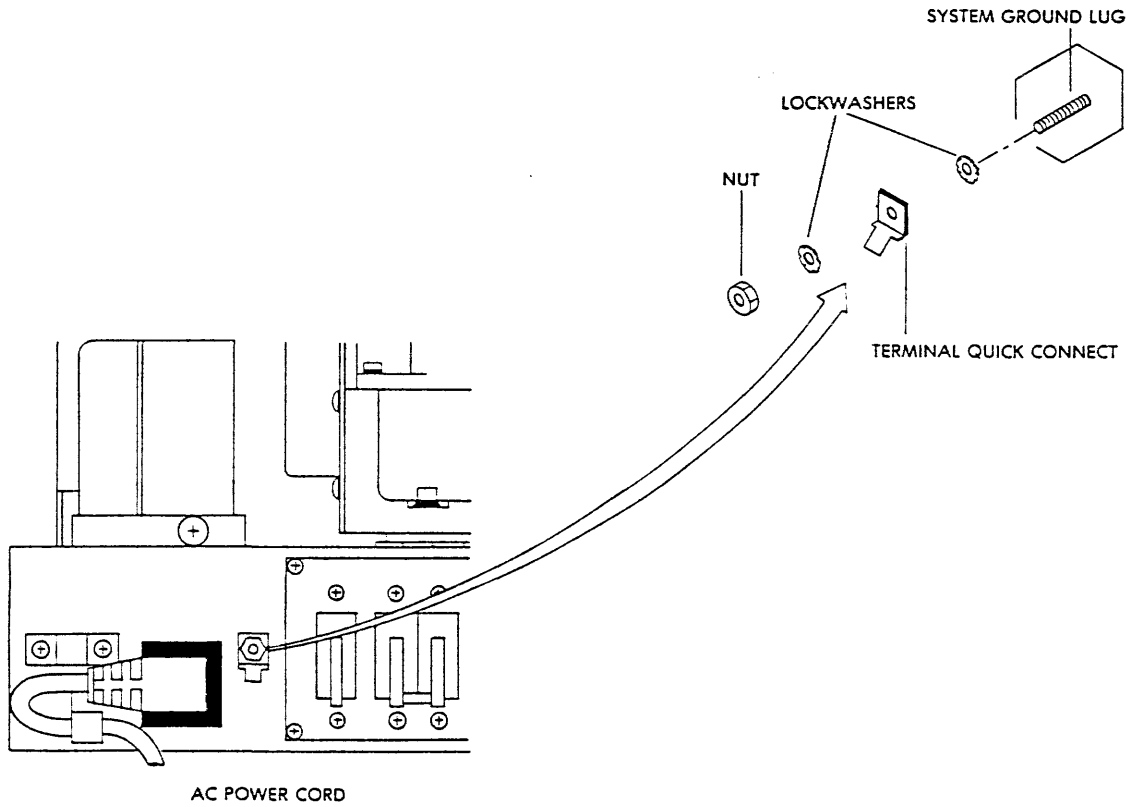

Figure 9-3. SI 9762 Grounding Lug

9.3 9762 Address Selection

This drive is assigned an address by installing a drive identifier plug in the drive front panel.

9.4 9762 Sector Count

Sector switches located on a card in the drive logic chassis must be set. On the SI 9762 drive, the card is the __LTV in slot B08. Figure 9-4 illustrates the switch location for the SI 9762. The switch settings are listed in Table 9-3.

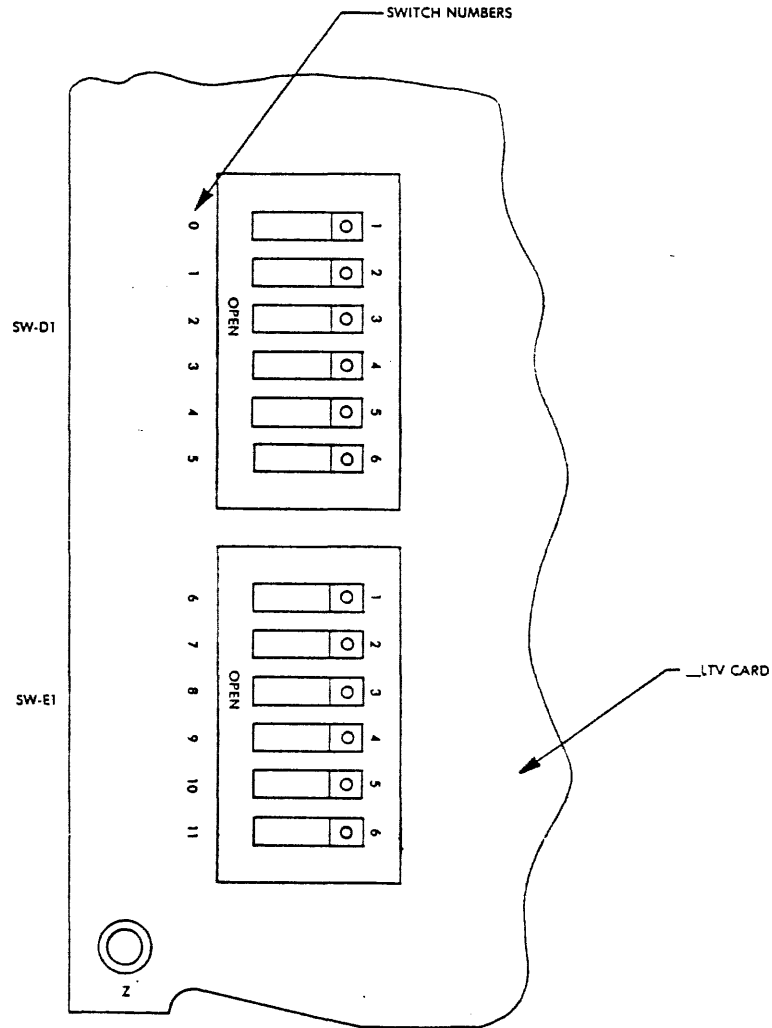

Figure 9-4. SI 9762 Sector Count Switch Location

Table 9-3. SI 9762 Sector Count Switch Settings

24 SECTORS		32 SECTORS		33 SECTORS		35 SECTORS	
SWITCH#	SETTING	SWITCH#	SETTING	SWITCH#	SETTING	SWITCH#	SETTING
0	ON	0	ON	0	OFF	0	ON
1	ON	1	ON	1	ON	1	ON
2	ON	2	OFF	2	ON	2	ON
3	ON	3	OFF	3	OFF	3	ON
4	OFF	4	OFF	4	ON	4	ON
5	ON	5	ON	5	OFF	5	ON
6	OFF	6	OFF	6	OFF	6	OFF
7	OFF	7	ON	7	ON	7	ON
8	OFF	8	ON	8	ON	8	OFF
9	ON	9	OFF	9	OFF	9	OFF
10	OFF	10	OFF	10	OFF	10	OFF
11	OFF	11	OFF	11	OFF	11	OFF

ON=Closed
OFF=Open

9.5 9762 Drive Index and Sector Signals

Unless otherwise specified, this drive is supplied from System Industries with the A-cable gated option. A jumper on the __TVV card (slot B01) changes the A-cable index and sector signals from gated to continuous.

Index and sector signals on older drives can be converted to B-cable only by removing and adding wirewraps on the logic backplane. This physically moves the index and sector signals from the A-cable to the B-cable.

Newer drives have additional B-cable index and sector transmitters that are not gated with unit-selected signals within the drive, and they are independent of the __TVV card jumper. These signals are made available by removing a plug on slot B07 of the backplane. With the plug in place, the signals are disabled and thus are prevented from reaching the B-cable.

Drive index/sector signal routing and gating options are as follows:

- A-cable gated** The jumper on the __TVV card (slot B01) must be in the gated position. The card should be identified as FTVV. Dual channel drives have a second card in slot B03 which must be similarly jumpered and identified (see Figure 9-5).
- A-cable continuous** The jumper on the __TVV card (slot B01) must be in the continuous position. The card should be identified as GTVV. Dual channel drives have a second card in slot B03 which must be similarly jumpered and identified (see Figure 9-6).
- B-cable continuous** On newer drives (series code 39 and later), the B-cable signals must be enabled by removing the grounding plug on slot B07 of the backplane (see Figure 9-7).

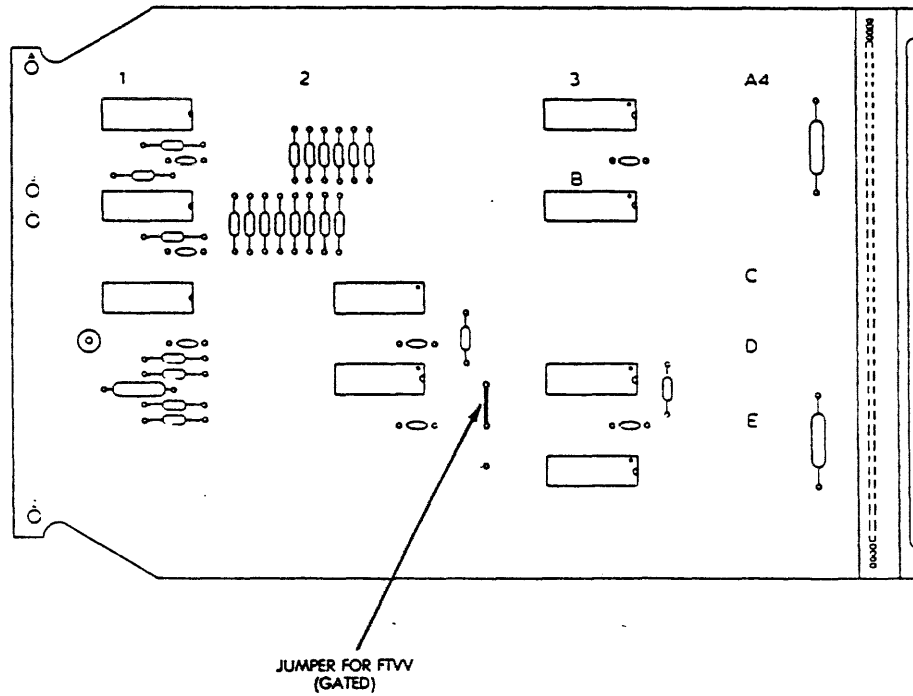

Figure 9-5. TVV Card Jumpered for A-Cable Gated

NOTE

The position of the jumper on the TVV card does NOT affect the B-cable signals on the newer drives. However, it should be in the gated position if B-cable index and sector signals are to be used.

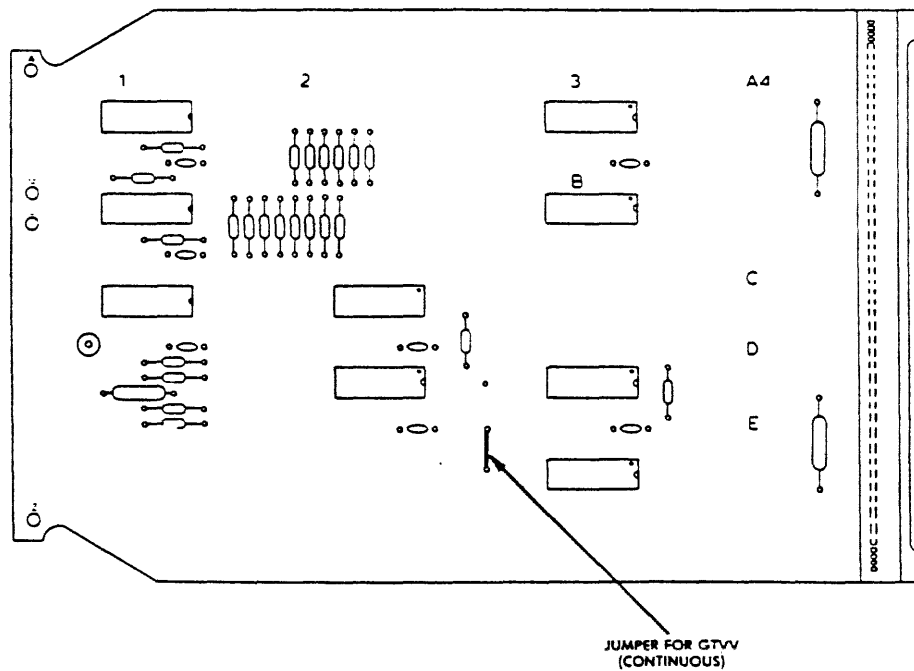

Figure 9-6. TVV Card Jumpered for A- or B-Cable Continuous

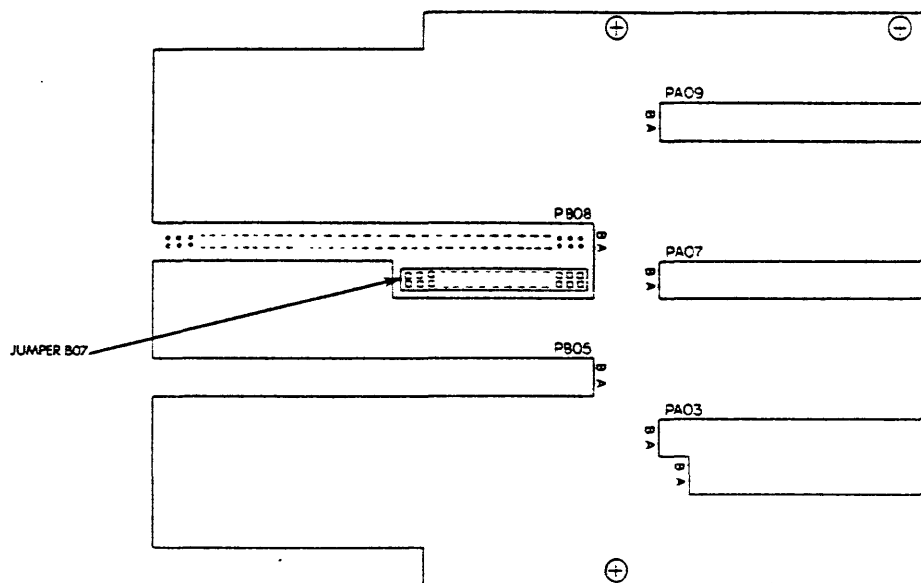

Figure 9-7. 9762 Backplane Slot B07 Grounding Plug

On older drives (prior to series code 39), the index and sector signals must be moved from the A-cable to the B-cable. To do this, remove the following wirewraps on the logic backpanel:

From	To
B01-06B	JA82-18B
B01-06A	JA82-18A
B01-05B	JA82-25B
B01-05A	JA82-25A
B03-06B	JA83-18B
B03-06A	JA83-18A
B03-05B	JA83-25B
B03-05A	JA83-25A

Add the following wirewraps to the logic backpanel:

From	To
B01-06B	JA82-43B
B01-06A	JA82-44A
B01-05B	JA82-45B
B01-05A	JA82-45A
B03-06B	JA83-43B
B03-06A	JA83-44A
B03-05B	JA83-45B
B03-05A	JA83-45A

Be sure the jumper(s) on the __TVV card(s) (slots B01 and B03 for dual channel) are in the continuous position and the card(s) are identified as GTVV (see Figure 9-6).

9.6 9762 Radial Cabling

The shielded cable I/O bracket for this drive is mounted at the back of the cabinet at its base. The bracket is illustrated in Figure 9-8. The internal A- and B-cable assemblies should have been mounted on the bracket and connected to the IF card, in which case follow step 1 and steps 7-10 in the procedure below. If not, do steps 2-6 also. The installation of the internal cables requires the following hardware:

- 10-32 3/8 inch machine screws
- 10-32 hex nuts
- #10 split tooth lock washers
- Connector clip sets

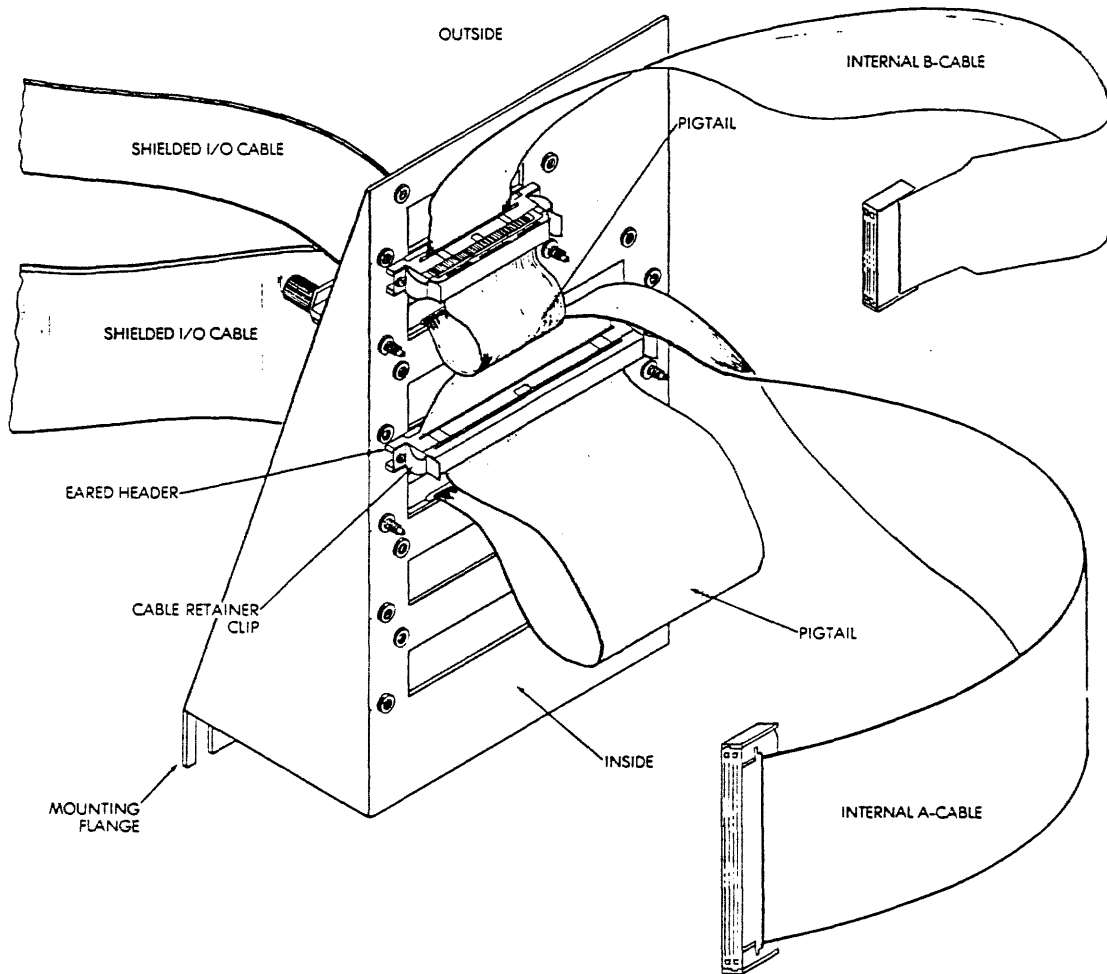

Figure 9-8. 9762 Shielded Cable I/O Bracket

1. Open the rear door of the cabinet and remove the adapter bracket.
2. Install a cable clip in each of the ears on the internal B-cable flanged connector. Using the screws, lock washers, and hex nuts provided, mount the header immediately above one of the 26-size ports at the top of the bracket on the inside.
3. Connect the internal B-cable to IJ2 on the drive interface card.
4. Repeat steps two and three for the A-cable flanged connector using a 60-size port, connecting the A-cable to IJ3 on the IF card.
5. Install a terminator at IJ4.
6. Remount the I/O bracket.
7. Feed the pigtails of the external I/O cables through the appropriate slots and mount the shield terminators.
8. Loop the pigtails back and seat the connectors on the A- and B-cable flanged connectors on the inside of the bracket.
9. Remount the bracket.
10. Repeat this procedure until all drives have been connected.

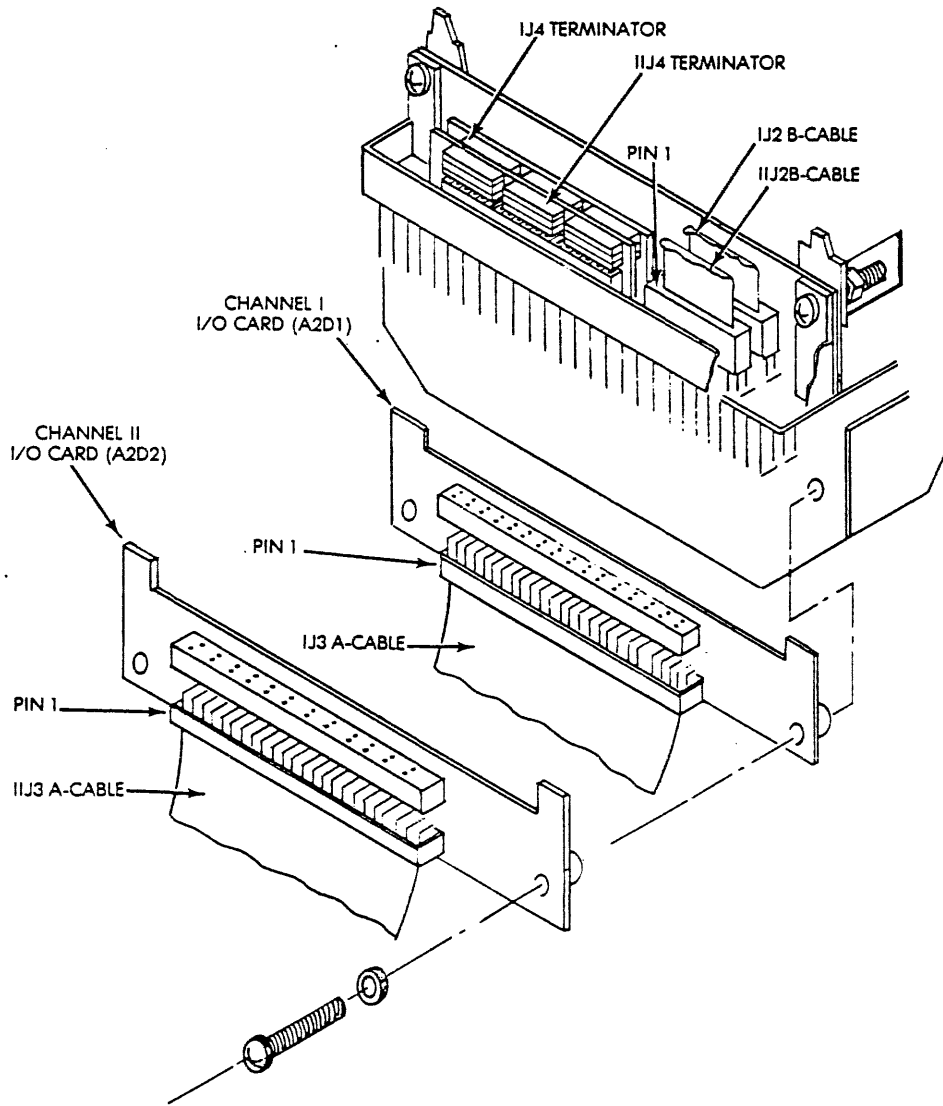

Figure 9-9. SI 9762 Radial Cabling

9.7 9762 Daisy-chain Cabling

The shielded cable I/O adapter bracket is located at the back of the drive at the base. The bracket is shown in Figure 9-8. Figure 9-10 illustrates daisy-chain cabling for the 9762 drives (single channel shown for clarity). The internal A- and B-cable assemblies should have been mounted on the bracket and connected to the IF card, in which case follow step 1 and steps 6-12 in the procedure below. If not, do steps 2-5 also. The installation of the internal cables requires the following hardware:

- 10-32 3/8 inch machine screws
- 10-32 hex nuts
- #10 split tooth lock washers
- Connector clip sets

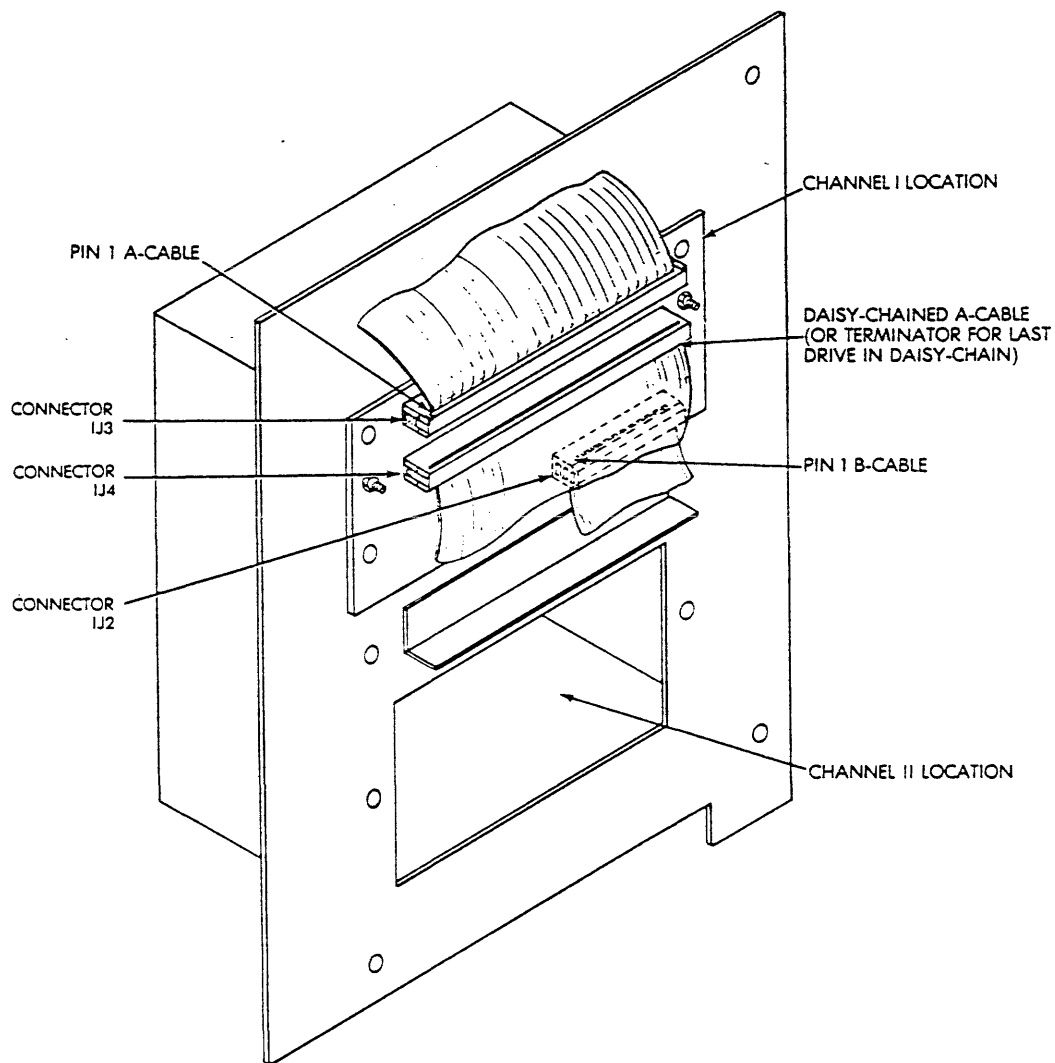

Figure 9-10. 9762 Daisy-chain Cabling

1. Open the rear door and remove the adapter bracket.
2. Install a cable clip in each of the ears on the internal B-cable flanged connector. Using the screws, lock washers, and hex nuts provided, mount the header immediately above one of the 26-size ports at the top of the bracket on the inside.
3. Run the internal B-cable to IJ2 in the drive IF card.
4. Repeat steps two and three for the A-cable flanged connector using a 60-size port, connecting the internal A-cable to IJ3 on the IF card.
5. Remount the I/O bracket.
6. Feed the pigtails of the external I/O cables through the appropriate slots and mount the shield terminators.
7. Loop the pigtails back and seat the connectors on the A- and B-cable flanged connectors on the inside of the bracket.
8. Repeat steps 1-5 for each additional drive if necessary.
9. Insert the pigtail of the outgoing shielded A-cable in the next 60-size port and mount the shield terminator.
10. Connect the pigtail to IJ4 on the IF card.
11. Run the shielded A-cable to the next drive in the chain and repeat whichever of the above steps are applicable.
12. Install a terminator in IJ4 on the last drive in the chain.

SECTION 10 SI 9784 DISK DRIVE

The SI 9784 is a 160 Mbyte fixed media disk drive to be rack mounted in an FCC-compliant cabinet.

10.1 9784 Power Requirements

The site must provide an AC power source for each drive. The SI 9784 draws all power from its own power supply unit, which is connected to the site AC power.

Sixty-Hertz power supply units are supplied with a 3-pin, 15-amp, 125-volt power connector (NEMA configuration 5-15P). The mating receptacle must be NEMA configuration 5-15R; e.g., Hubbell 5262. Fifty-Hertz drives are not supplied with a power connector.

The AC voltage requirements and the maximum current requirements are listed in Tables 10-1 and 10-2.

Table 10-1. SI 9784 Voltage Requirements

VAC	RANGE (VAC)	FREQUENCY (HZ)	RANGE (HZ)
100	90—110	60	57.6—61.2
120	106—128	60	57.6—61.2
220	203—235	50	49.0—50.5
240	213—257	50	49.0—50.5

Table 10-2. SI 9784 Maximum Current Requirements

VAC	HZ	OPERATING* CURRENT (AMPS)
100	60	2.5
115	60	3.0
220	50	2.0
240	50	2.0

*This drive does not operate in standby mode. The disks are always in motion while the drive is powered up.

The power supply unit is connected to the SI 9784 by three cable assemblies furnished with the drive. The AC cable supplies AC power to drive the spindle motor, brake, and the blower motor. The DC cable and the attached power control connector supply DC power to the logic and analog circuits.

The 60 Hz version of the power supply unit operates at 100 or 120 VAC, and the 50 Hz version operates at 220 or 240 VAC. The procedure for connecting the drive to the power supply unit and selecting the AC input voltage is as follows:

1. Selecting input AC voltage:

- a. Remove the power supply cover. It is held in place with four screws on each side on the bottom and two screws on the top.
- b. On the right side of the transformer is a small terminal strip labeled INPUT. A white wire fastened to the terminal strip by a screw can be positioned in one of two locations labeled AC100V and AC120V (Figure 10-1).

NOTE

A label on top of the power supply unit indicates which voltage was set at the factory.

- c. The procedure for selecting 220 VAC/240 VAC on the 50 Hz version is the same.

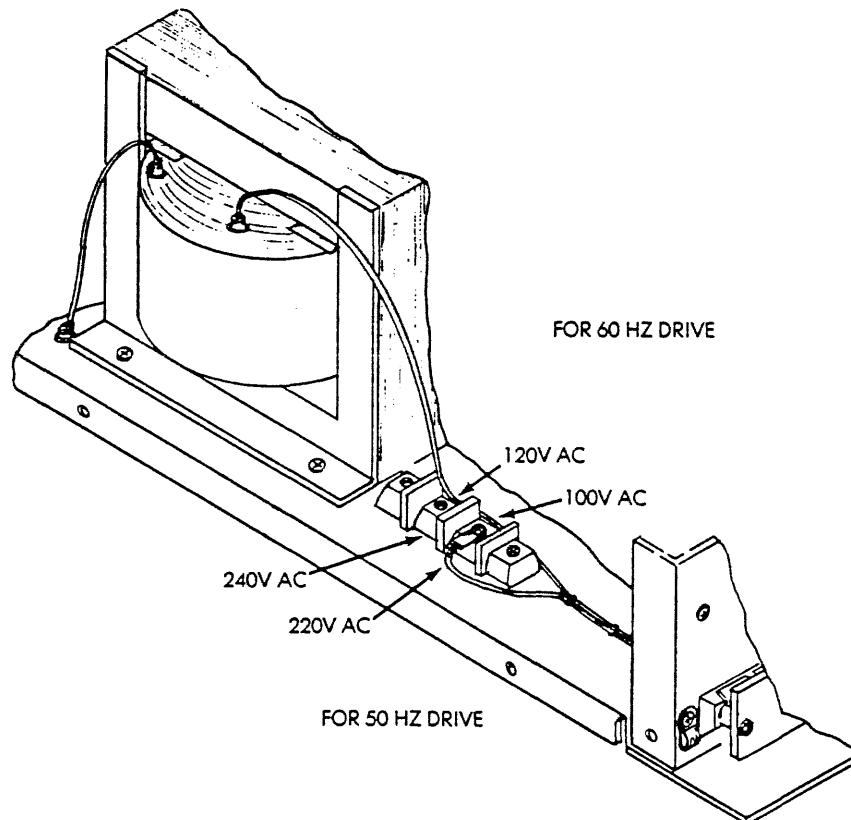

Figure 10-1. SI 9784 AC Voltage Selection, 50/60 Hz

2. Selecting +24 DC Voltage:

Both the 60 Hz and 50 Hz versions of the power supply have one output which is switch selectable, either +24 VDC or -32 VDC. The 60 Hz drive requires +24 VDC. Confirm that the switch on the rear of the power supply unit is set for +24V (Figure 10-2).

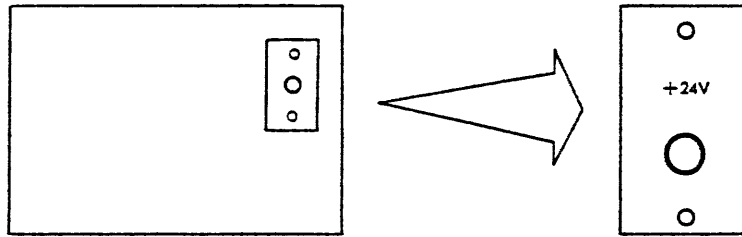

Figure 10-2. 9784 +24 or -32 VDC Select Switch

3. Power Cable Connection:

The SI 9784 has three power cable connectors. Connect the AC cable connector (PW1) to PW1 on the power supply unit. Connect the DC cable connector (PW2) to PW2 on the power supply unit. Connect the power control connector (CN1) to CN18 on the power supply unit (Figures 10-3 and 10-4).

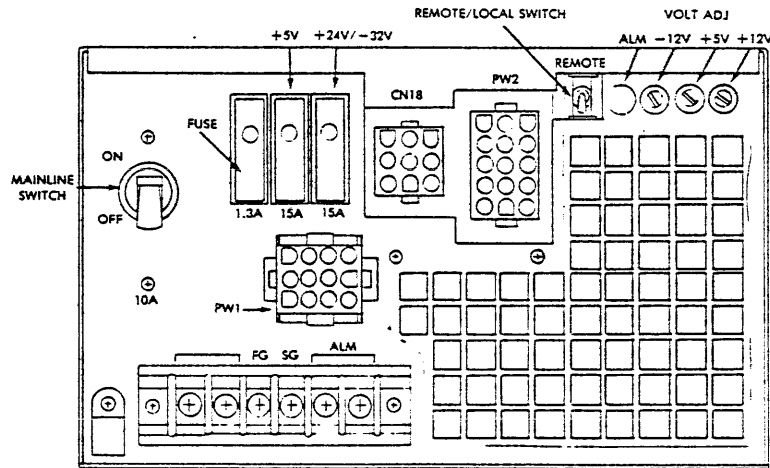

Figure 10-3. Power Cable Connection for SI 9784, 50 Hz

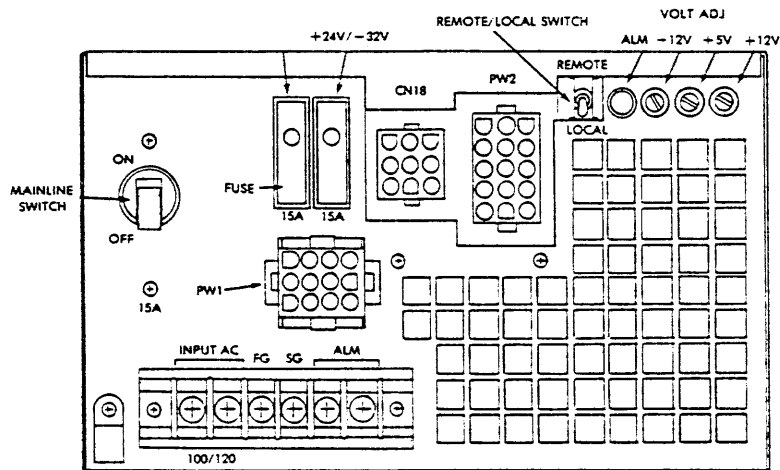

Figure 10-4. Power Cable Connection for SI 9784, 60 Hz

10.2 9784 Grounding Requirements

There are three types of grounding. The first two depend on the requirements of the system. The third is mandatory.

1. Drive Ground

The frame ground (FG) and the signal ground (SG) within the drive are separated. If the system requires FG and SG to be connected, attach the grounding cable between SG and the ground terminal (GND) (Figure 10-5). If the system requires a ground between the system and the drive, attach the ground conductor to the GND terminal on the drive.

2. Power Supply Unit Ground

FG and SG terminals are provided on the power supply unit (Figures 10-3 and 10-4). System ground requirements and power distribution will determine whether or not FG and SG are to be connected.

3. Daisy-chain Grounding Cable

An auxiliary grounding cable must be daisy-chained from the SG terminal on one drive to the SG terminal on the next drive and from the SG terminal of the last drive in the chain to the controller (Figure 10-6).

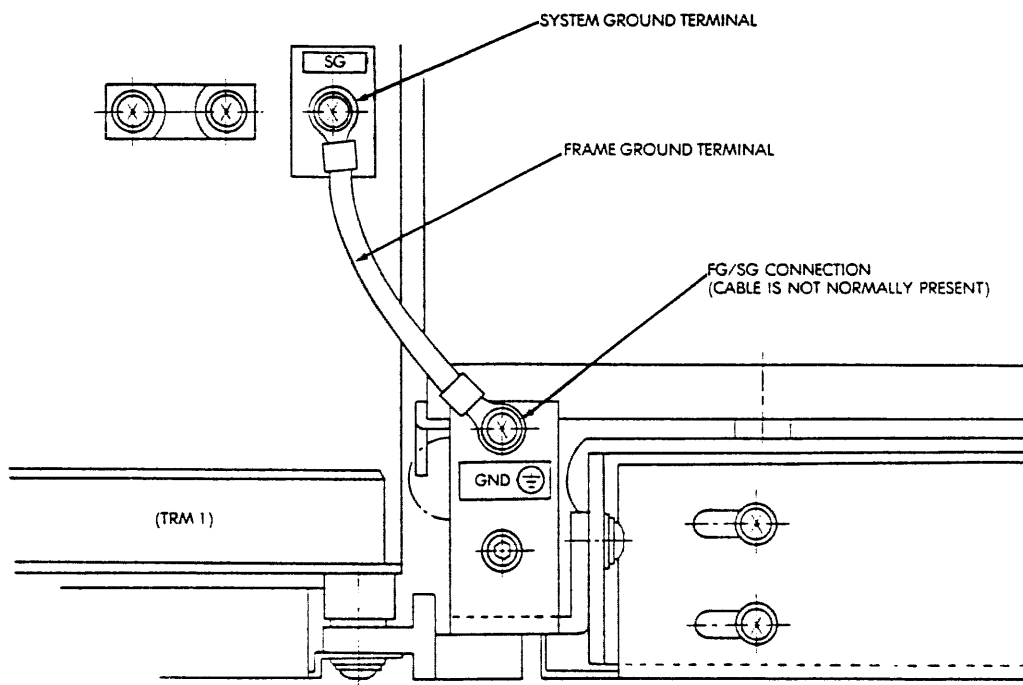

Figure 10-5. SI 9784 Drive Ground Terminal

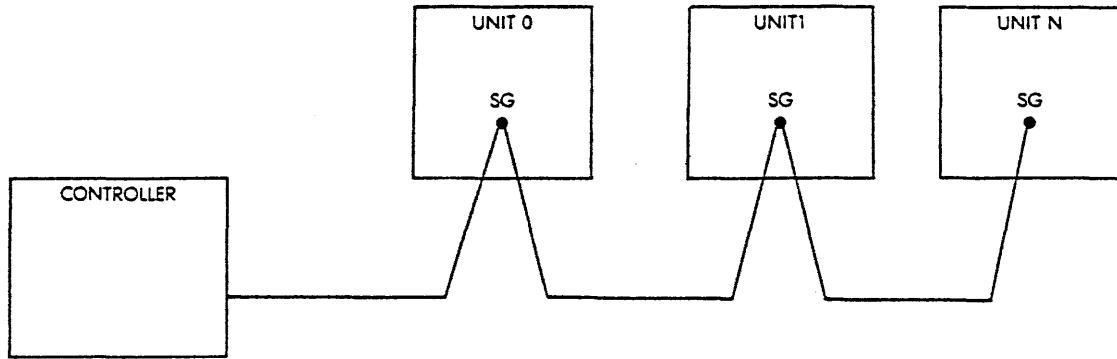

Figure 10-6. SI 9784 Auxiliary Ground Cable

10.3 9784 Address Selection

Unit addresses are selected for this drive with dipswitch assembly SW1, switches SW1-1 through SW1-3., SW1 is located on the CQFM PCB assembly at J2 (Figure 10-7). Table 10-3 lists the switch settings.

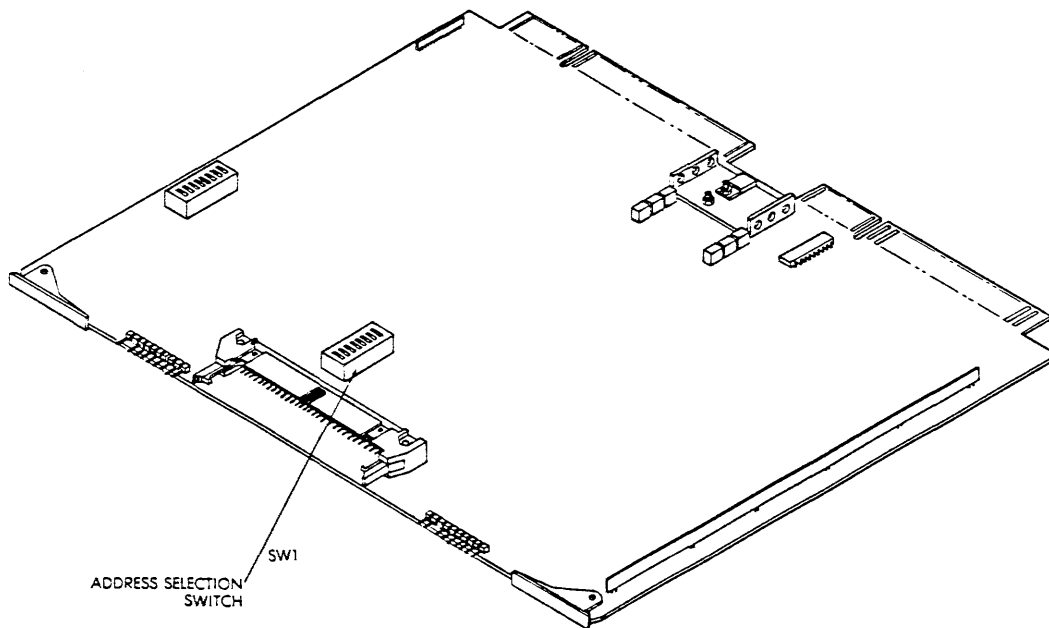

Figure 10-7. SI 9784 Address Switch Location on CQFM PCB

Table 10-3. SI 9784 Address Selection Switch Settings

DISK ADDRESS	SWITCH NUMBERS AND SETTINGS		
	SW1-1	SW1-2	SW1-3
0	OFF	OFF	OFF
1	ON	OFF	OFF
2	OFF	ON	OFF
3	ON	ON	OFF
4	OFF	OFF	ON
5	ON	OFF	ON
6	OFF	ON	ON
7	ON	ON	ON

ON = CLOSED
OFF = OPEN

10.4 9784 Sector Count

The sector count is set via switch packs SW1 and SW2. These switch packs are located at L2 and L1 on the VOFM PCB assembly (Figure 10-8). Each switch pack is numbered 1-7. Switch settings are listed in Table 10-4.

NOTE

If it is necessary to set up the SI 9784 to enable soft sectoring, set switch 7 in SW2 to the ON position. This switch is located at P3 on the CMKM board. In newer drives the card designation is CQFM, but the switch setting is the same.

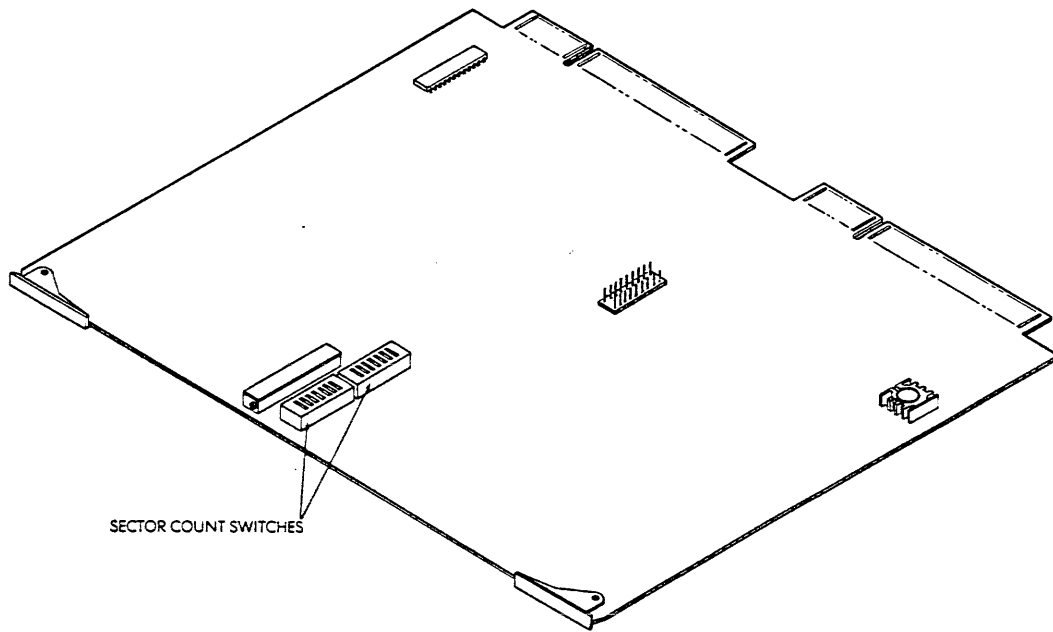

Figure 10-8. SI 9784 Sector Count Switch Locations on VOFM PCB

Table 10-4. SI 9784 Sector Count Switch Settings

24 SECTORS		29 SECTORS*		32 SECTORS		33 SECTORS		35 SECTORS	
SWITCH#	SETTING	SWITCH#	SETTING	SWITCH#	SETTING	SWITCH#	SETTING	SWITCH#	SETTING
SW1 1	ON	SW1 1	OFF	SW1 1	ON	SW1 1	ON	SW1 1	ON
2	OFF	2	ON	2	ON	2	ON	2	OFF
3	ON	3	OFF	3	ON	3	OFF	3	OFF
4	OFF	4	OFF	4	ON	4	ON	4	ON
5	ON	5	OFF	5	ON	5	OFF	5	OFF
6	OFF	6	OFF	6	ON	6	ON	6	OFF
7	ON	7	ON	7	ON	7	ON	7	ON
SW2 1	OFF	SW2 1	ON	SW2 1	OFF	SW2 1	OFF	SW2 1	OFF
2	ON	2	OFF	2	OFF	2	OFF	2	OFF
3	ON	3	ON	3	ON	3	ON	3	ON
4	OFF	4	OFF	4	OFF	4	OFF	4	OFF
5	OFF	5	OFF	5	OFF	5	OFF	5	OFF
6	OFF	6	OFF	6	OFF	6	OFF	6	OFF
7	OFF	7	OFF	7	OFF	7	OFF	7	OFF

*SDA50E and QDA50E Controllers.

NOTE

For SI 9784 drives used in conjunction with System Industries disk controllers, the 35 sector switch settings are different from the 35 sector switch settings as calculated from the Fujitsu Fixed Disk Unit Customer Engineering Manual.

10.5 SI 9784 Drive Index and Sector Signals

This drive has one option: A-cable gated and B-cable continuous. No modifications can be made.

10.6 SI 9784 Radial Cabling

The following instructions assume the use of a System Industries FCC-compliant cabinet. If the controller and drives are in the same cabinet, no shielded drive cables are needed. Follow steps 1 and 2 below. If the controller is in another cabinet, follow steps 4-7.

1. Run an internal A-cable from the controller RDI board to connector OM2 on the disk drive.
2. Run an internal B-cable from the RDI board to OM3 on the disk drive.
3. Install a terminator at OM1 on each drive.

4. If the controller is in another cabinet, run four internal A- and four internal B-cables from the RDI board to the transition panel in the controller cabinet.
5. Run four pairs of shielded A- and B-cables from the transition panel to the transition panel of the drive cabinet. Terminate the shields and connect the cables to the appropriate connectors on the transition panel.
6. Run internal A- and B-cables from the transition panel assembly connector board to OM2 and OM3, respectively, on each drive.
7. Install terminators at OM1 on each drive.

For dual channel configurations repeat the above procedure connecting the A- and B-cables to OM2B and OM3B on the dual channel adapter board and install terminators at OM1B.

Figures 10-9 and 10-10 illustrate single channel and dual channel radial cabling.

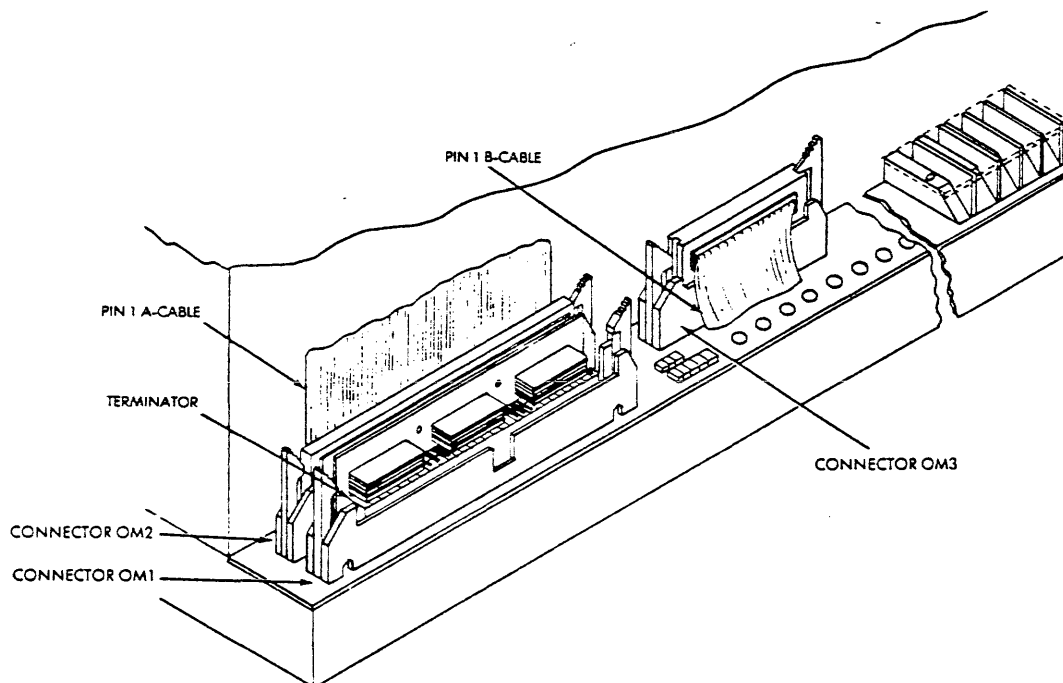

Figure 10-9. 9784 Radial Cabling, Single Channel

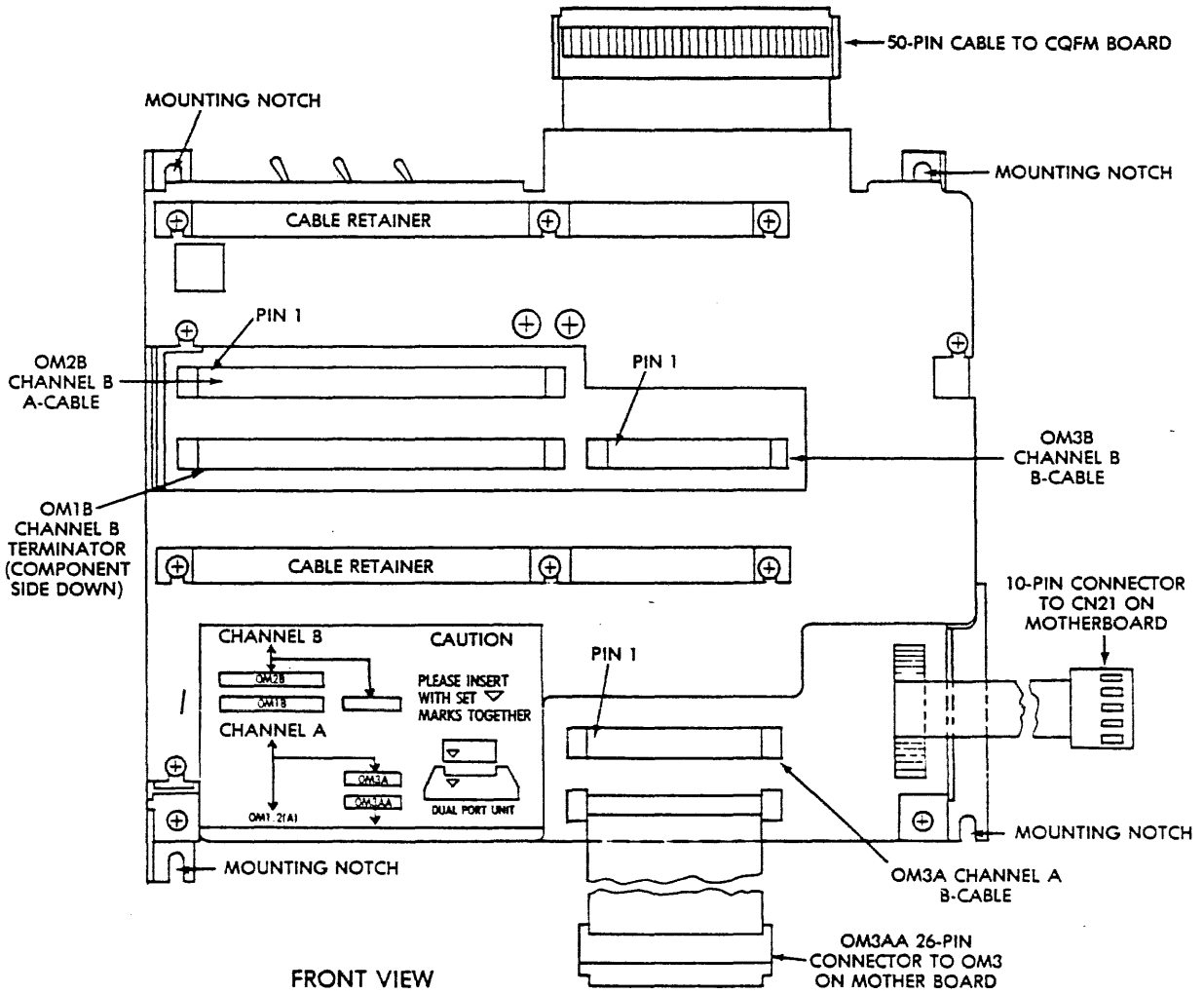

Figure 10-10. 9784 Radial Cabling, Dual Channel

10.7 9784 Daisy-chain Cabling

The following instructions assume the use of the System Industries FCC-compliant cabinet. If the controller and drives are in the same cabinet, no shielded drive cables are needed. Follow steps 1 and 2 below. If the controller is in another cabinet, do steps 3-10.

1. Remove the terminators from OM1 on all but the last drive. Run an internal A-cable from the controller to OM2 on the first drive. Run another A-cable from OM1 on the first drive to OM2 on the next drive. Repeat until all drives are connected. Install a terminator at OM1 on the last drive.
2. Run B-cables from the controller to OM3 on each drive.
3. If the controller and possibly additional 9798s are in another cabinet, cable the drives as in steps 1-2, but do not terminate the last drive. Run an A-cable from OM1 to the transition panel assembly connector board.
4. Run as many B-cables from the controller as there are remaining drives to be connected in the other cabinet. Connect the B-cables from the controller to the transition panel.
5. Run a shielded A-cable from the transition panel in the controller cabinet to the transition panel in the cabinet housing the remaining drives. Be sure the cable shields are terminated at each cabinet. Connect the shielded A-cable pigtail to a 60-pin connector on the connector board.
6. Run an internal A-cable from the transition panel assembly connector board to OM2 on the first drive.
7. Run another A-cable from OM1 on the first drive to OM2 on the next. Repeat until all drives are connected. Install a terminator at OM1 on the last drive.
8. Run shielded B-cables from the controller cabinet to the other drive cabinet. Terminate the external cables at both cabinets.
9. Connect the pigtails of the shielded B-cables to the 26-pin connectors on the connector board.
10. Run internal B-cables from the connector board to OM3 on each drive.

For dual channel configurations repeat the above procedure connecting the A- and B-cables to OM1B, OM2B, and OM3B and install the terminator at OM1B on the last drive.

Figures 10-11 and 10-12 illustrate single and dual channel daisy-chain cabling for the 9784 disk drive. Figure 10-13 provides more detail of dual channel cabling.

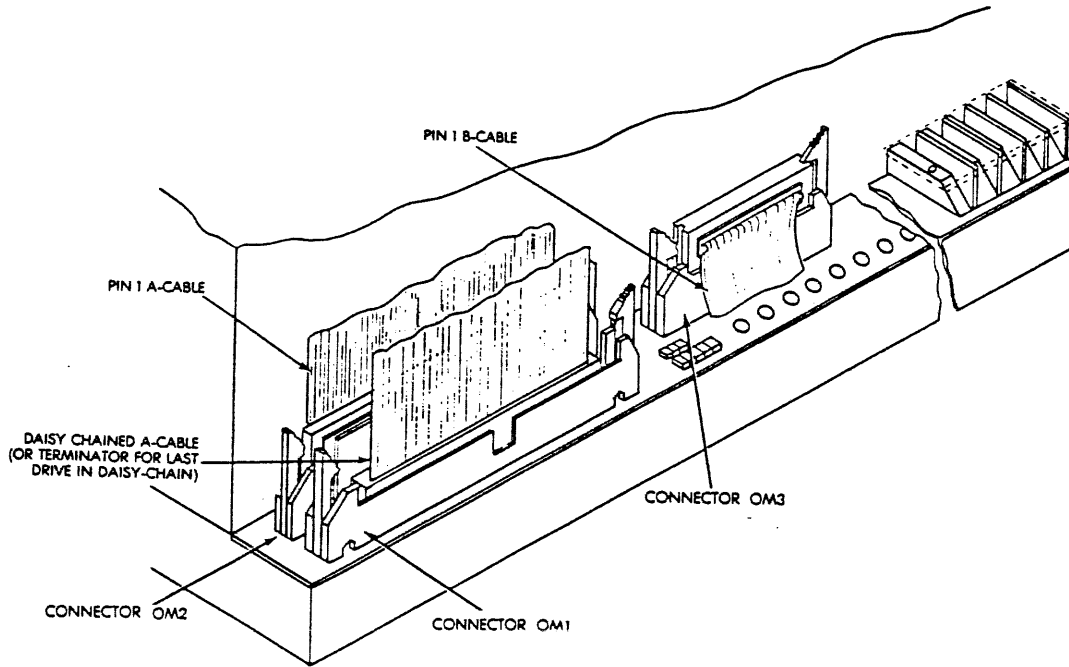

Figure 10-11. 9784 Daisy-chain Cabling, Single Channel

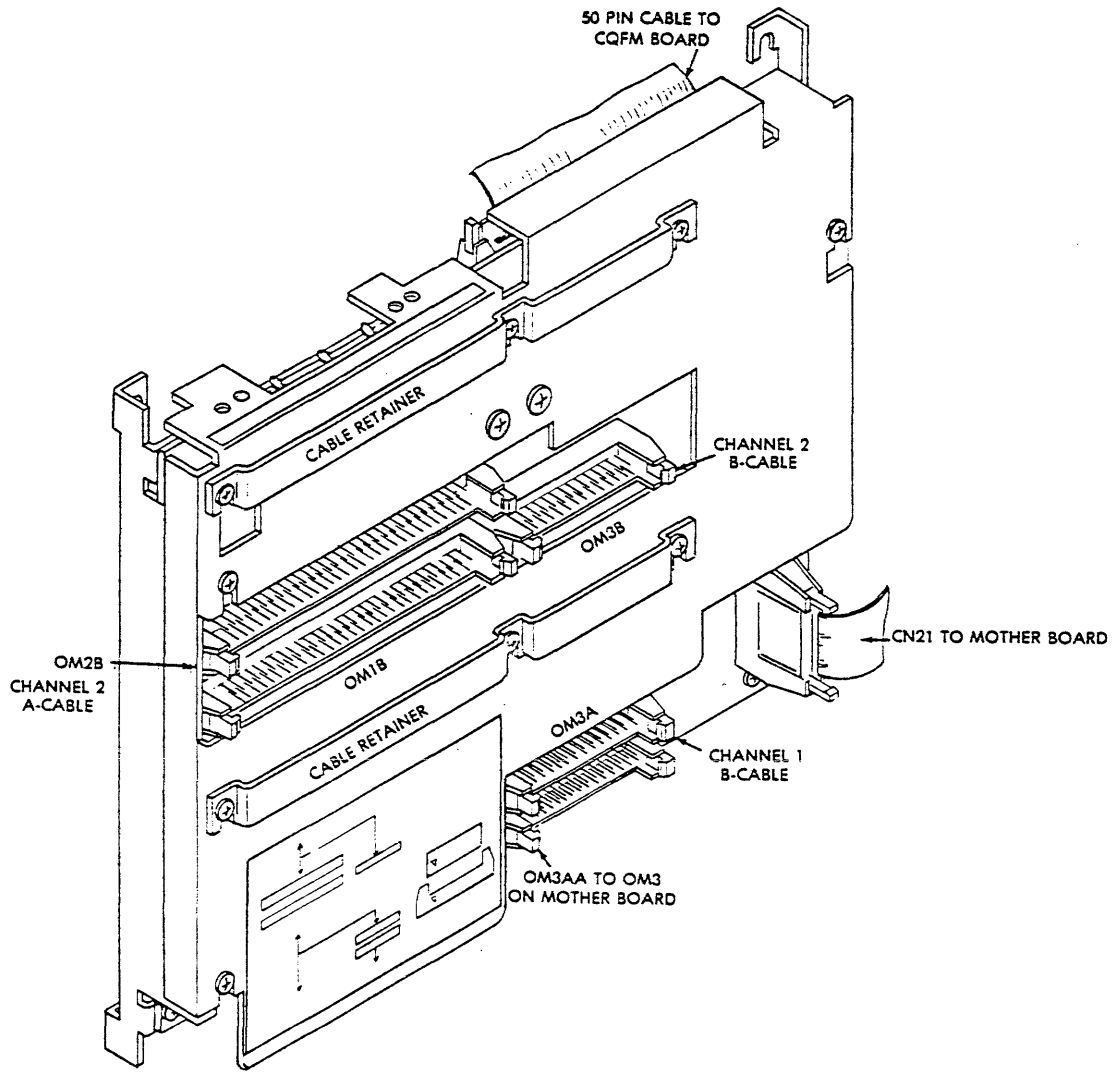

Figure 10-12. 9784 Daisy-chain Cabling, Dual Channel

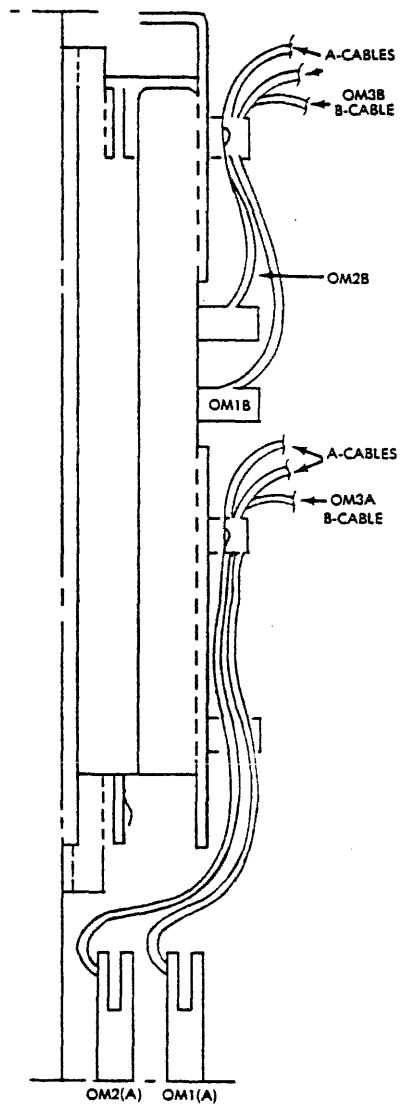

Figure 10-13. 9784 Daisy-chain Cabling, Dual Channel, (Side Detail)

APPENDIX A DAISY-CHAIN ADAPTER

The SI Daisy-chain Adapter allows one or more disk drives to be removed from the user's system without disturbing the operation of the remaining daisy-chained drives. The adapter is used in both single- and dual-channel disk drive applications. Currently, the daisy-chain adapter is used only with System Industries 9400/9800/9900 Controllers.

A.1 Configurations

The daisy-chain adapter is compatible with any 9400/9800/9900 daisy-chain system configuration. No operating system modifications are necessary.

A.2 Physical Description

The daisy-chain adapter assembly consists of a printed circuit board mounted in a sheet metal box. The PCB measures 5 inches × 9 inches (12.7 cm × 22.9 cm) and is attached inside the box with seven machine screws. The enclosure measures 5½ inches × 10½ inches (14.0 cm × 26.7 cm) and has a hinged top panel that allows for the termination of shielded cables (Figures A-1 and A-2).

A.3 Controller Interface

Each daisy-chain adapter is connected to any pair of controllers via four shielded interface cables. These cables consist of two A/B pairs, one pair assigned to each controller.

One A-cable from each controller is connected to the first adapter in the daisy-chain. The A-cables are then daisy-chained from one succeeding adapter to the next. The B-cables are radially connected from each controller to each of the adapters in the chain (Figure A-3).

The A-cables are shielded 60-conductor flat cables. The B-cables are shielded 26-conductor flat cables. All cables are SMD interface compatible.

A.4 Disk Drive Interface

Each daisy-chain adapter interfaces to the system disk drives with standard shielded SMD-interface cables. One A-/B-pair is assigned to each channel of a dual-channel drive.

A.5 Functional Description

The daisy-chain adapter assembly allows removal of one or more drives from a disk storage subsystem with no effect on the remaining on-line drives. This is accomplished through the use of an electrically passive adapter board. The adapter PCB provides a parallel current path for signals carried by the A-cables, which is common to all drives.

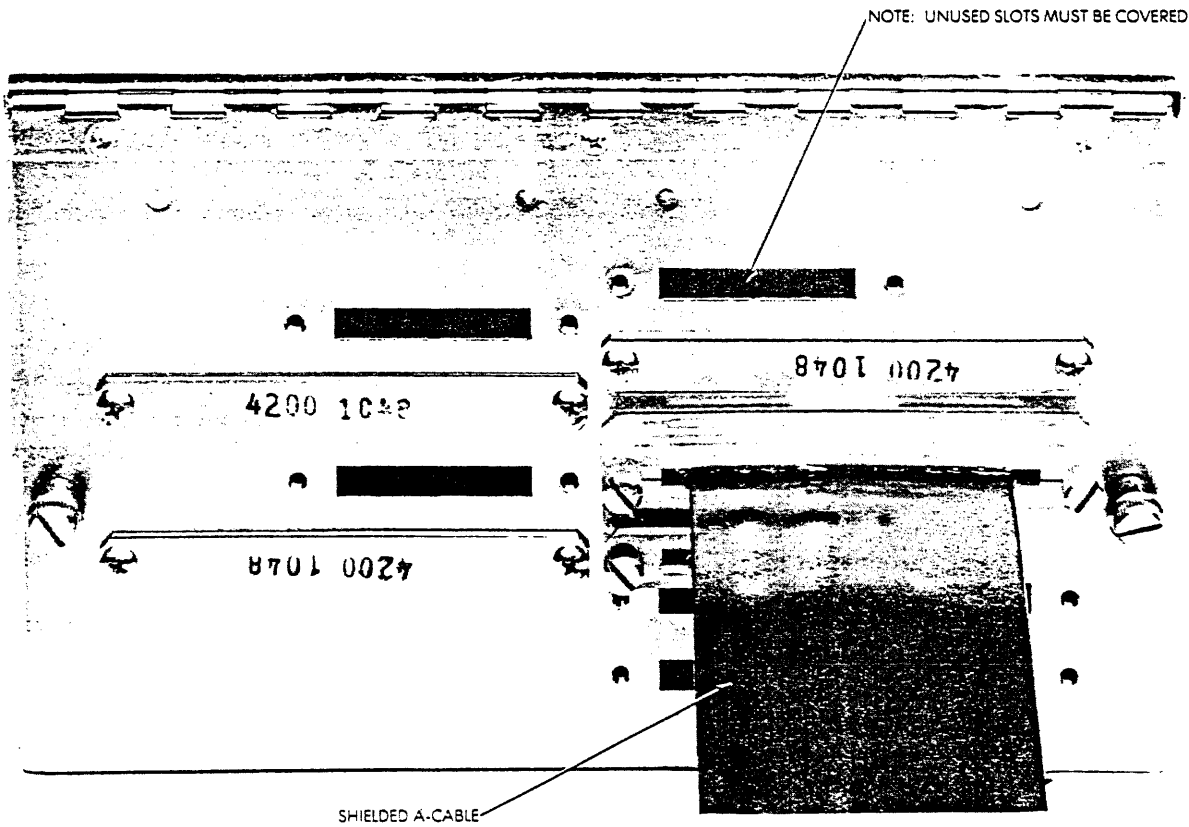

Figure A-1. Daisy-chain Adapter Housing

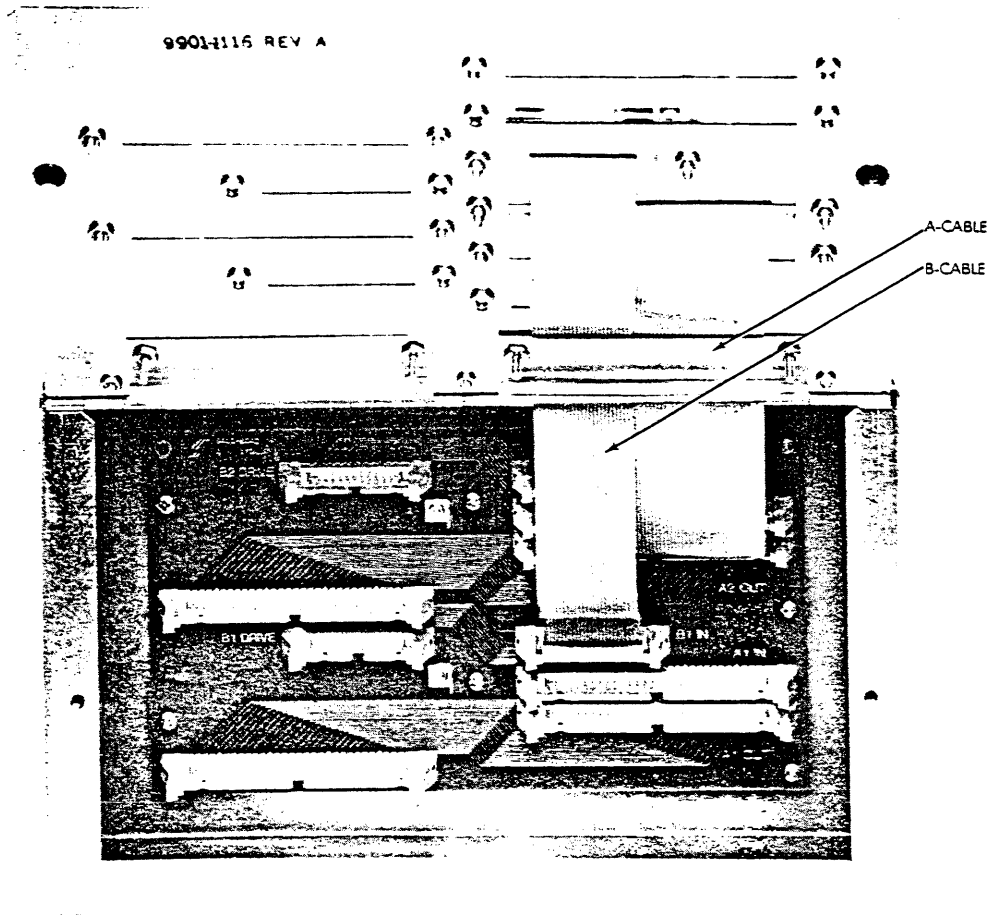

Figure A-2. . Daisy-chain Housing (Interior View)

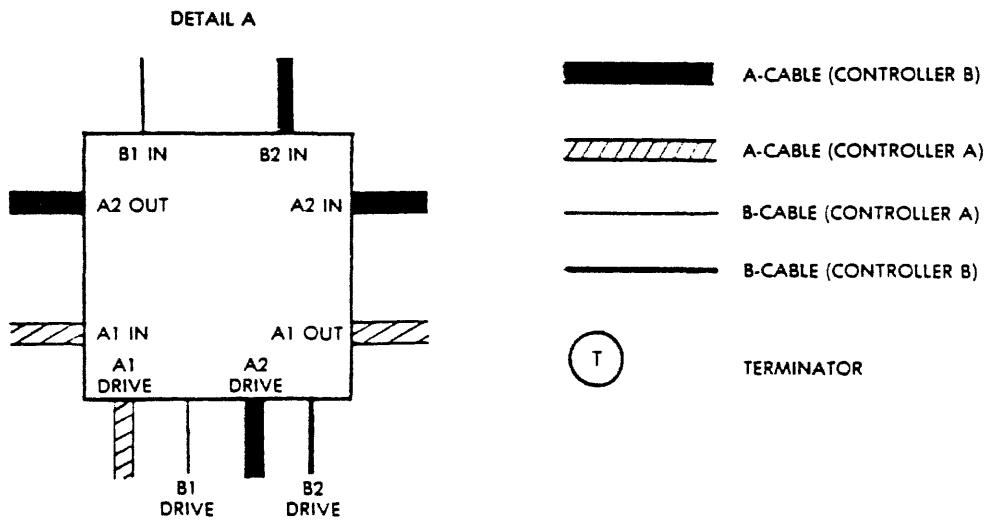
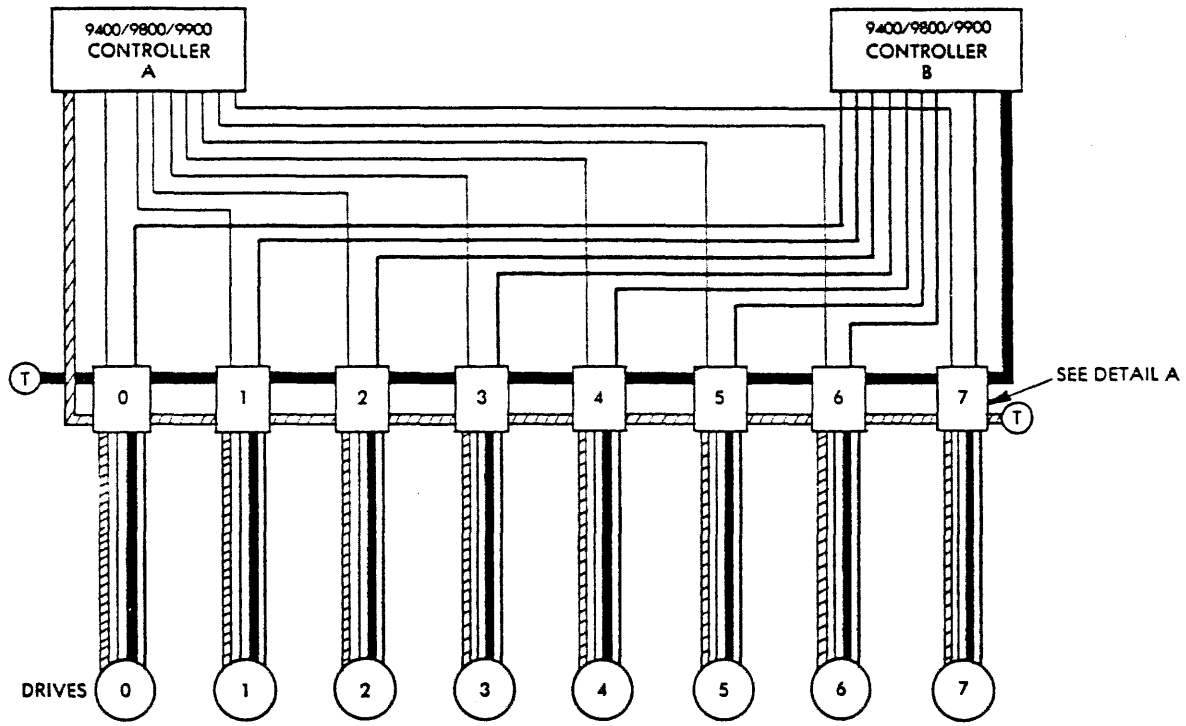

Figure A-3. Daisy-chain Adapter Interconnect Diagram

A.6 Installation

This paragraph describes the procedures to cable a daisy-chain adapter to a user's system in a dual channel configuration.

A.6.1 Visual Inspection

Before attempting to cable the adapter, do a visual inspection of the assembly to verify the following:

- All components are undamaged, in place and secure.
- Connector pins for the A-/B-cables are undamaged.
- Cables are undamaged, and the pin receptacles are secure.
- Shield terminators are properly installed on the cable shields.

A.6.2 Daisy-chain Adapter Cabling

The following procedure describes how to cable a maximum of eight daisy-chain adapters and disk drives to a pair of controllers designated in this procedure as I and II.

CAUTION

Before performing any cabling, verify that the system is powered down.
Refer to the applicable DEC publication.

Whenever inserting cables into connectors, be sure that the arrow on the cable is aligned with the corresponding arrow on the connector.

Two pairs of A-/B-cables (9901-7116 and 9901-7118) are supplied with each adapter assembly. They are standard 5-foot (1.52 m) shielded SMD interface cables. These cables connect the drive to the daisy-chain adapter.

A.6.2.1 A-cabling for Controller I

The following steps describe how to connect the A-cables from the Controller I cable distribution assembly to the daisy-chain adapters:

1. Attach the cable shield terminators to the controller cable interface and the cable connector to the appropriate header on the PCB.
2. Loosen the two panel screws and open the hinged cover on the first daisy-chain adapter assembly.
3. Insert the flat cable connectors through the appropriate opening. Attach the shield terminators and connect the 60-conductor A-cable connector to A11N on the first adapter assembly.
4. After inserting the flat cable connectors through the panel openings, attach the shield terminators to the adapter assembly cover.

5. Install an A-cable connector from connector A1OUT on the first adapter assembly to connector A1IN on the second adapter assembly.
6. Repeat step 4 until all daisy-chain adapters are connected. Note that one adapter is required for each drive in the chain.
7. Terminate the A-cable at the last adapter in the chain at connector A1OUT.
8. Ensure that all shielded cable terminators are securely fastened.

A.6.2.2 B-cabling for Controller I

The following steps describe how to connect the B-cables from controller I to the daisy-chain adapter.

1. Attach the cable shield terminators to the controller cable transition panel and the 26-conductor cable connector to the appropriate header on the PCB.
2. Additional B-cable connectors are located on the transition boards. Attach one end of each of the remaining B-cables to these connectors terminating the shields. Label each cable sequentially.
3. After attaching the cable shield terminators to the adapter box cover, connect the free end of each B-cable to connector B1IN of each succeeding daisy-chain adapter

A.6.2.3 A-/B-cabling for Controller II

Follow the preceding cabling instructions to cable controller II. Label A-cables A2. A connectors on the adapters are labelled A2IN/A2OUT. B-cables are connected as in the preceding subparagraph. B connectors on the adapters are designated as B2IN. Be sure that the B-cables going to controller II are connected to the adapters in the same sequence as the B-cables going to controller I (i.e., each set of B0, B1, B2, ..., Bn cables should be connected to the same set of adapters). Terminate the A-cable at the last adapter in the chain at connector A2OUT.

A.6.3 Drive Cabling

The following steps describe how to connect the 5-foot (1.52-meter) SMD interface cables from the drives to be daisy-chained to the daisy-chain adapters.

1. Secure the shield terminators on the appropriate controller transition panels and the daisy-chain adapter assemblies.
2. Attach one end of the A-cable to channel 1 of drive 0. Attach the free end to connector A1DRIVE on the daisy-chain adapter.
3. Attach one end of a B-cable to channel 1 of drive 0. Attach the free end to connector B1DRIVE on the daisy-chain adapter cabled in the preceding step.
4. Attach one end of the A-cable to channel 2 of drive 0. Attach the free end to connector A2 DRIVE on the adapter cabled in the preceding step.

5. Attach one end of a B-cable to channel 2 of drive 0. Attach the free end to connector B2DRIVE on the adapter cabled in the preceding step.
6. To cable the remaining drives, repeat steps 1-4 above. Be sure that each drive is cabled to an adapter that has B-cables corresponding to the drive's logical unit number, e.g. B0, B1, ...,B7.

NOTE

To ensure maximum shielding integrity, all unused I/O bracket ports must have port cover plates securely mounted.

7. Secure the controller transition panel and all daisy-chain adapter top panels.

NOTE

The A-cable terminators in the drives must be removed when using the daisy-chain adapter.

A.6.4 Adapter Cabling in Single Channel Configuration

The adapter cabling procedure can be modified to allow cabling of daisy-chain adapters to systems with single channel configurations. This is accomplished by omitting the following:

- A-/B-Cabling: Controller II
- Steps 3 and 4 in Drive Cabling



APPENDIX B DUAL CHANNEL ADAPTER FOR 9784 DRIVE

The SI Dual Channel Adapter (107-9001) provides for dual-channel configurations in SI 9784 drives with serial numbers above 1200. The following paragraphs describe the adapter and explain how to install it.

The adapter consists of a printed circuit board (XCBM), left and right mounting brackets, a cover plate, three cables (50-, 26-, and 10-conductor), one cable retainer, and four mounting screws. The unit comes with the mounting brackets attached to the PCB (XCBM) and the three cables already connected to the board (XCBM).

The 50-conductor cable is connected to the adapter at location CN31, the 26-conductor at Location CN34, and the 10-conductor at location CN32 (Figure B-1).

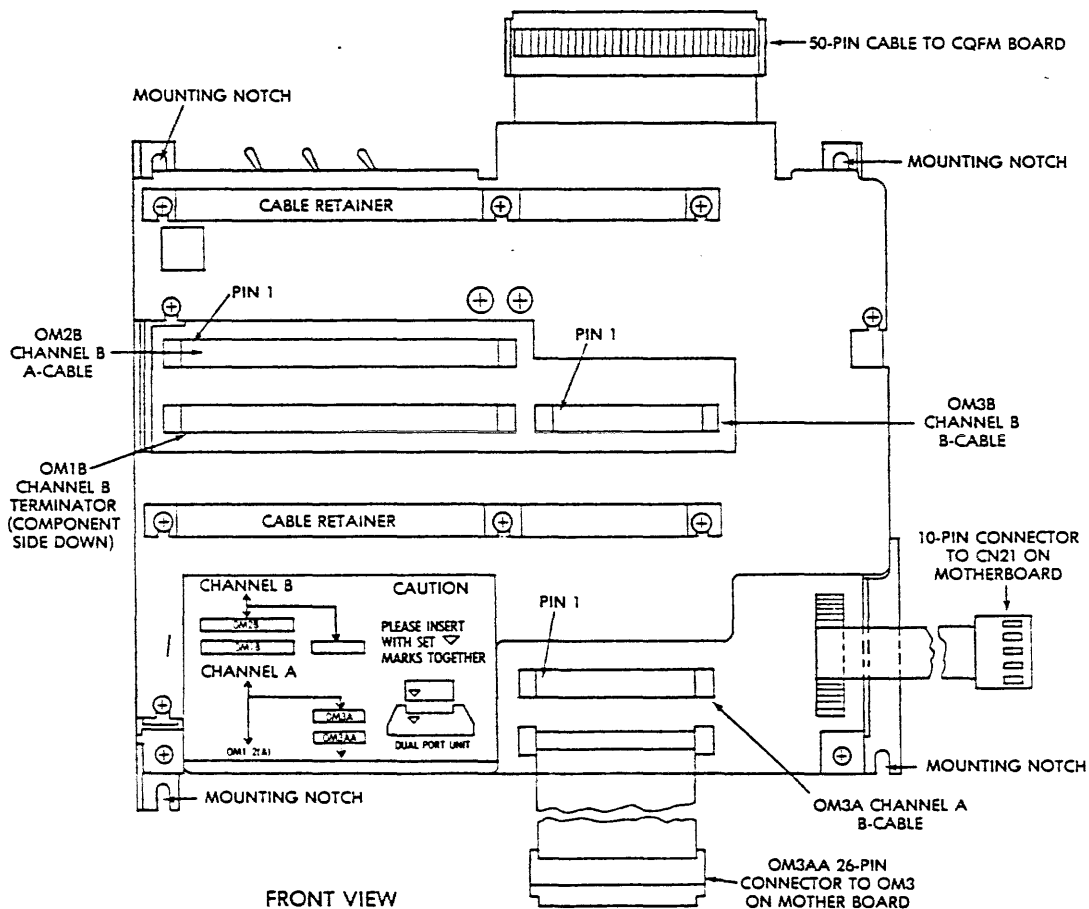

Figure B-1. Dual Channel Adapter

B.1 Installing the Dual Channel Adapter

1. Install the four mounting screws in the four tapped holes on the rear of the drive PCB chassis.
2. Remove the cable retainer and save it for use on the adapter cover plate when cabling the drive.
3. Place the adapter in such a manner that the elongated notches on the mounting brackets rest on the screws. Tighten the screws. See Figure B-1.
4. After the adapter has been mounted, connect the three cables as follows:
 - a. Remove the top cover of the drive card cage. Plug the free end of the 50-conductor cable onto CN30 on the CQFM PCB. Replace the top cover.
 - b. Plug the free end of the 26-conductor cable onto OM3 on the motherboard.
 - c. Plug the free end of the 10-conductor cable onto CN21 on the motherboard. (Note that this cable is keyed by a plugged pin receptacle.)
5. Install the Channel B terminator with the components facing down in order to maintain pin 1 to pin 1 correspondence. Figure B-1 shows the adapter cabled for dual-channel operation.

B.2 Operation Switches and LEDs

The unit's operation switches and LEDs are located on top of the adapter, as shown in Figure B-2. There are four LEDs and three switches. The LEDs, their colors, and what they indicate are as follows:

- CHB Orange: Indicates the Channel B controller has reserved this drive.
- CHB Green: Indicates the Channel B controller has selected this drive.
- CHA Orange: Indicates the Channel A controller has reserved this drive.
- CHA Green: Indicates the Channel A controller has selected this drive.

Switch	Function
DB-NRB	Setting the switch to DB (Disable B) disconnects the drive from the channel B controller. Setting the switch to NRB (Normal B) connects the drive to the channel B controller.
RLTM-ABSL	Setting this switch to RLTM (Release Timer) releases the reserved condition from the drive side 500 ms after the drive was last selected. Setting the switch to ABSL (Absolute) releases the reserved condition from the controller side by a software command from the computer.
DA-NRA	Setting the switch to DA (Disable A) disconnects the drive from the channel A controller. Setting the switch to NRA (Normal A) connects the drive to the channel A controller.

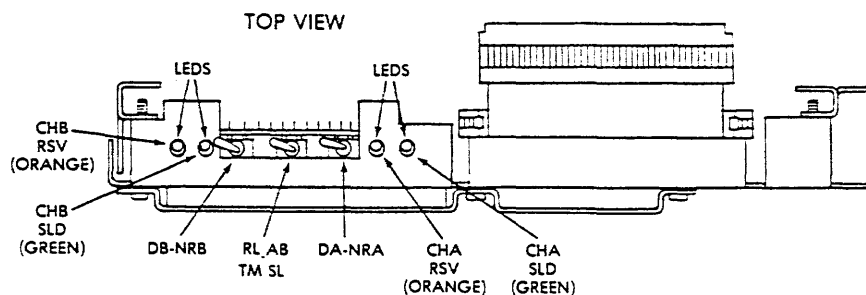

Figure B-2. Location of Dual-Channel Adapter Switches and LEDs



APPENDIX C

SI 9722/9733 DUAL PORT OPTION

The dual port option allows two controllers to access a given drive. The dual port PCB mounts on top of the power supply unit. The dual port unit consists, basically, of the following components:

- PCB mounted in a metal frame
- Mounting rails
- Retainer springs
- Brackets
- Four 14-conductor ribbon cables
- Cover
- B-cable
- Cable guide.

C.1 Installation

This paragraph describes installation and cabling procedures, referencing Figures C-1 and C-2.

CAUTION

When mounting anything on the power supply unit the maximum screw length is 6.00 mm. Using longer screws could cause a short within the power supply. Use only metric screws.

C.1.1 Assembling and Mounting the Dual Port Option

CAUTION

Before proceeding with the installation be sure that the drive(s) has been disconnected from the AC power source.

The procedure for installing the dual port option is as follows:

1. Mount the brackets on the rails. Brackets are mounted so that the bracket lips face inward.
2. Install the two retainer springs on the two rails.
3. Attach the rails to the top of the power supply unit using the six screws provided. Be sure the ends of the rails that the springs are attached to face toward the power supply control panel.
4. Mount the PCB on the frame with the four screws provided.
5. Install the PCB and frame assembly as follows:
 - a. Tilt the assembly by lowering the front end a bit (the end with the A- and B-cable connectors) and push the assembly forward on the rails until it compresses the springs slightly.
 - b. Lower the rear of the assembly and release it, allowing the PCB unit to automatically latch onto the bracket lips and seat itself.
6. Mount the cable guide with the two screws provided on the power supply control panel.
7. Install the PCB cover.

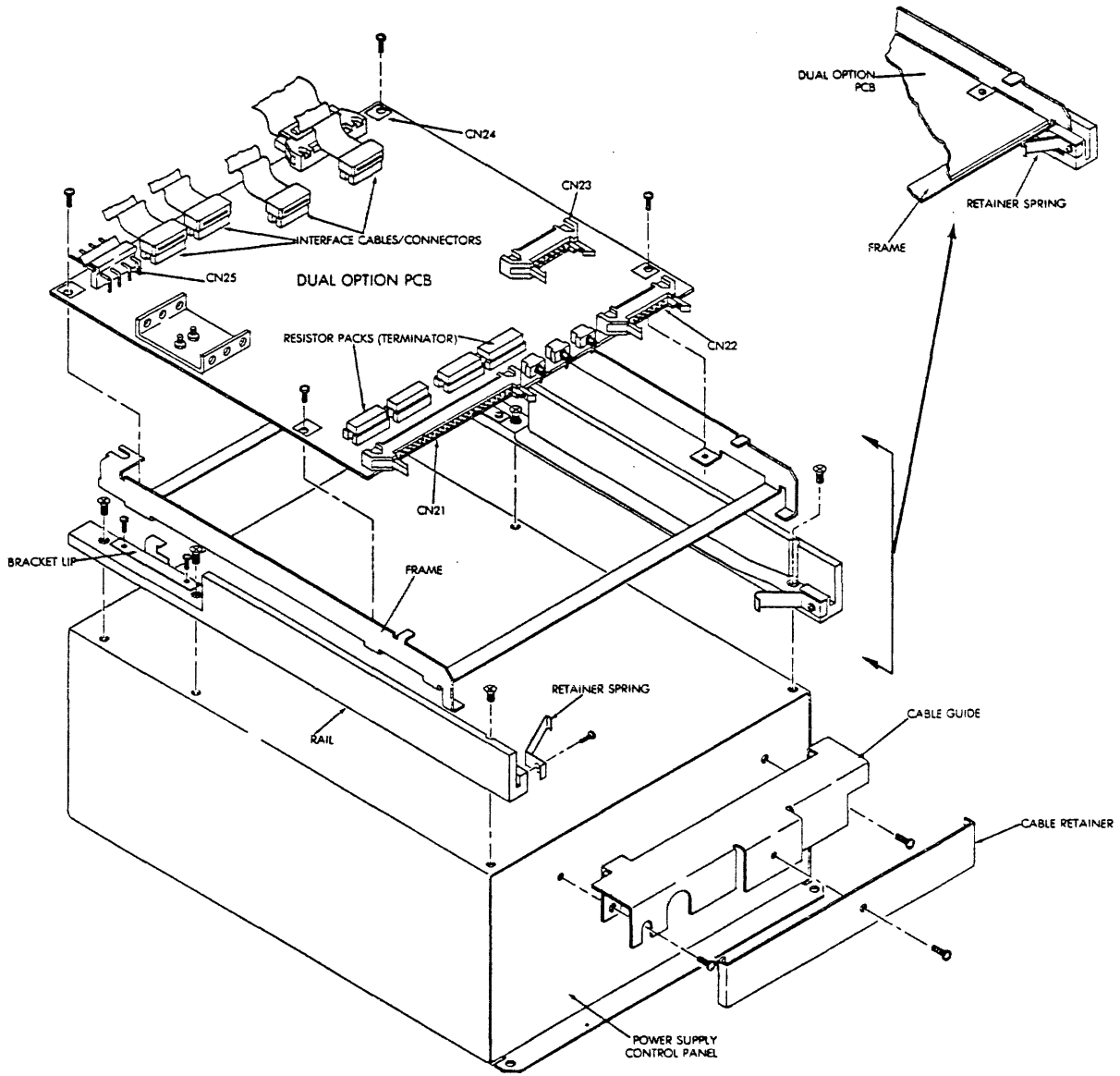

Figure C-1. Dual Option PCB Installation

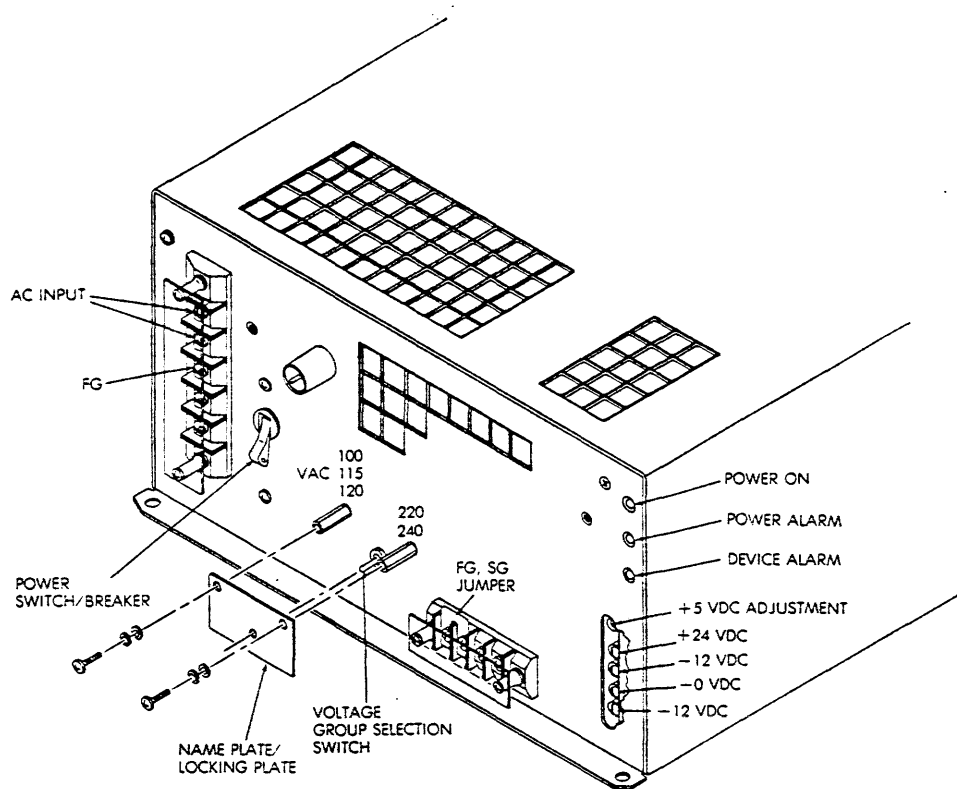

Figure C-2. Power Supply Control Panel

C.1.2 Cabling the Dual Port Option PCB

On this drive the channels are referred to as I and II. Cable the dual channel PCB as follows:

1. Remove the dual channel unit from the rails.
2. Run an A-cable (channel I or channel A) from CN1 on the CZFM board across the top of the power supply unit and out the back.
3. Replace the dual channel PCB.
4. Connect CN25 on the PCB to CN33 on the power supply with the power cable.
5. Connect the channel I or channel A B-cable to CN23 and run it behind the power supply.
6. Connect the 7.50 inch (19.1 cm) B interface cable from CN24 on the dual channel PCB to CN2 on the CZFM board.
7. Connect the four 14-conductor interface cables from the dual channel PCB to the CZFM board.
8. Connect the channel II or channel B A-/B-cables to CN21 and CN22 respectively.
9. Remove the retainer bar from the cable guide and fold the cables in the guide.
10. Replace the retainer bar.

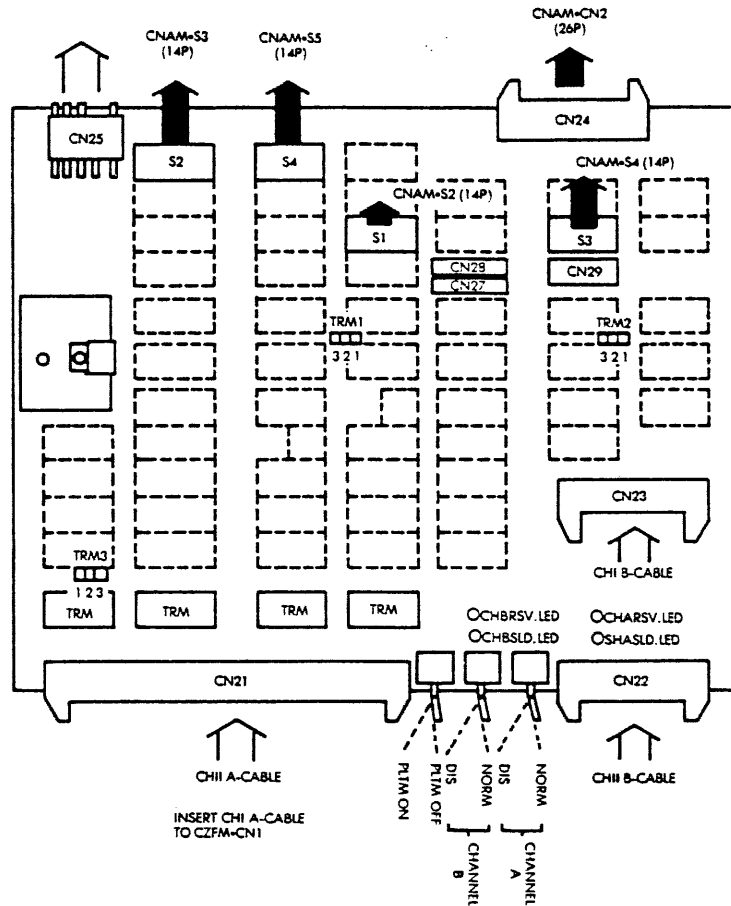

Figure C-3. Dual Channel PCB Layout

C.1.3 Dual Channel Option Controls and Indicators

There are three switches and four LEDs (two green and two orange) on the PCB (Figure C-3). The LEDs when lit indicate the following:

- CHBRSV (orange) That the channel B (II) controller has reserved this unit.
- CHARSV (orange) That the channel A (I) controller has reserved this unit.
- CHBSLD (green) That the channel B (II) controller has selected this unit.
- CHASLD (green) That the channel A (I) controller has selected this unit.

Behind the LEDs and between the B-cable connectors are three two-position switches. There are no function or designation labels on the switches. For purposes of this discussion they are designated, from left to right, 1, 2, and 3 (Figure C-3). Their functions and settings, referred to as 'left' and 'right' are listed in Table C-1.

Table C-1. Dual Option PCB Switch Settings and Functions

SWITCH NUMBER	SETTING	FUNCTION
1	Left	This is the RLTM (release timer) switch. When in the left position (release timer ON), RESERVED and PRIORITY SELECT are released approximately 500 ms after the drive has been deselected.
1	Right	Release timer OFF. When in this position, the RESERVED condition is released from the controller by TAG 3, BUS 9.
2	Left	Setting the switch in this position (DIS) disconnects the drive from the channel B (II) controller.
2	Right	Setting the switch in this position (NORM) connects the drive to the channel B (II) controller.
3	Left	Setting the switch in this position (DIS) disconnects the drive from the channel A (I) controller.
3	Right	Setting the switch in this position (NORM) connects the drive to the channel A (I) controller.

C.2 SI 9722 Front Panel Controls and Indicators

The SI 9722 drive is not equipped with a power switch on the front (operator) panel. The drive is powered up by the ON/OFF switch on the power supply.

There are four LEDs and two switches on the power supply control panel. The indicators are as follows:

- Power (red) LED lights when power is applied to the drive.
- Ready (red) Indicates one of the following:
Initial seek completed.
Termination of seek.
Termination of RTZ operation.
- Protect (white) Indicates that the drive is write protected.
- Check (red) Indicates a fault condition.

The two switches are protect (PTCT) and check clear. The PTCT switch sets write protect, and the clear switch resets device check status.



APPENDIX D

QUICK DISCONNECT SYSTEM

This appendix describes the SI Quick Disconnect Disk System and installation procedures.

The Quick Disconnect (QD) System allows the fast, easy removal of a modified SI 9722 or 9733 disk drive from a system without disturbing power and signal cabling. The QD can be used in all configurations supporting 9722 and 9733 drives.

It is intended for use in installations where it is necessary to remove hard disk drives from computing areas for security purposes, for interchanging data or programming disks, or for easy transport between computer sites.

D.1 Physical Description

The system consists of two main components:

- A chassis measuring 18 by 25 inches (45.7 by 63.5 cm) with mounting slides. The chassis contains the following:
 - Power supply
 - Backplane with controller and power cable interfaces
 - Quick release mechanism
- A modified 9722 or 9733 drive.

The system can be installed in any SI 42- or 60-inch FCC-compliant cabinet and requires a minimum of 10.5 inches (26.7 cm) of vertical rack space.

The modified drive's front panel, measuring 8.13 by 9 inches (20.6 by 22.9 cm), has a window that exposes the drive status LEDs and the write-protect switch.

At the rear of the chassis is the backplane that interfaces the power and signal cables to the drive (Figures D-1 and D-2). The drive's power supply is mounted on the left side of the chassis.

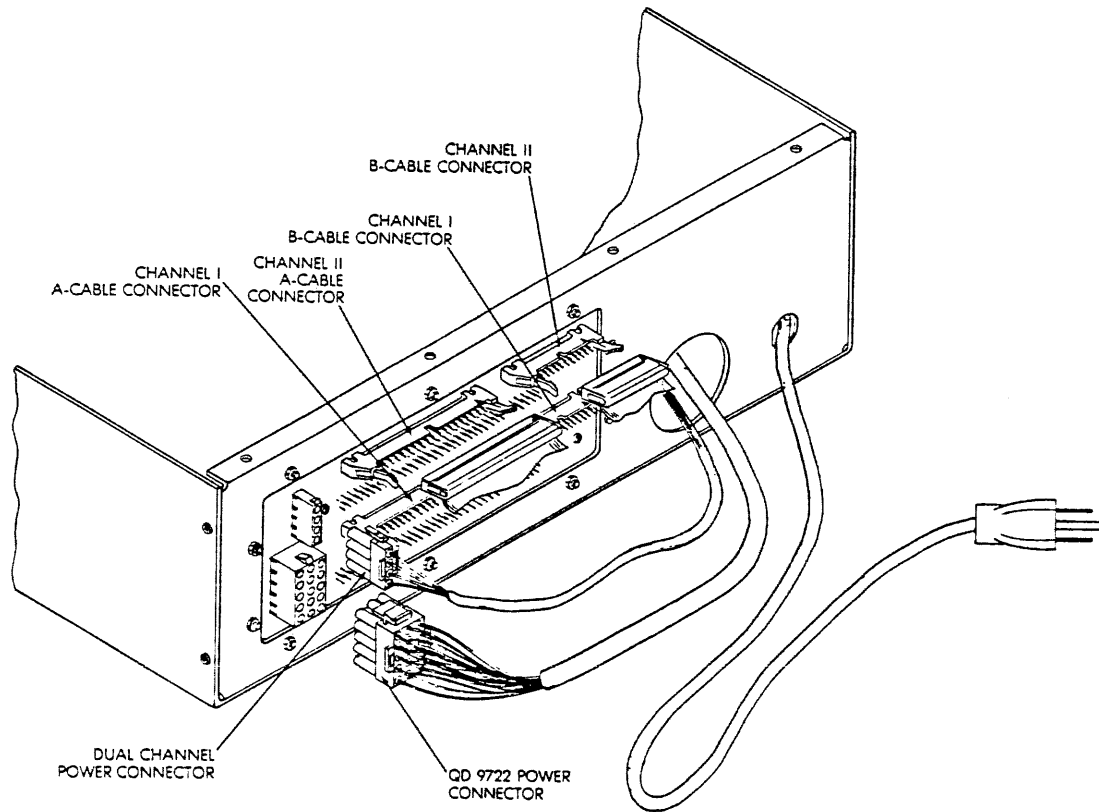

Figure D-1. Quick Disconnect (Rear View)

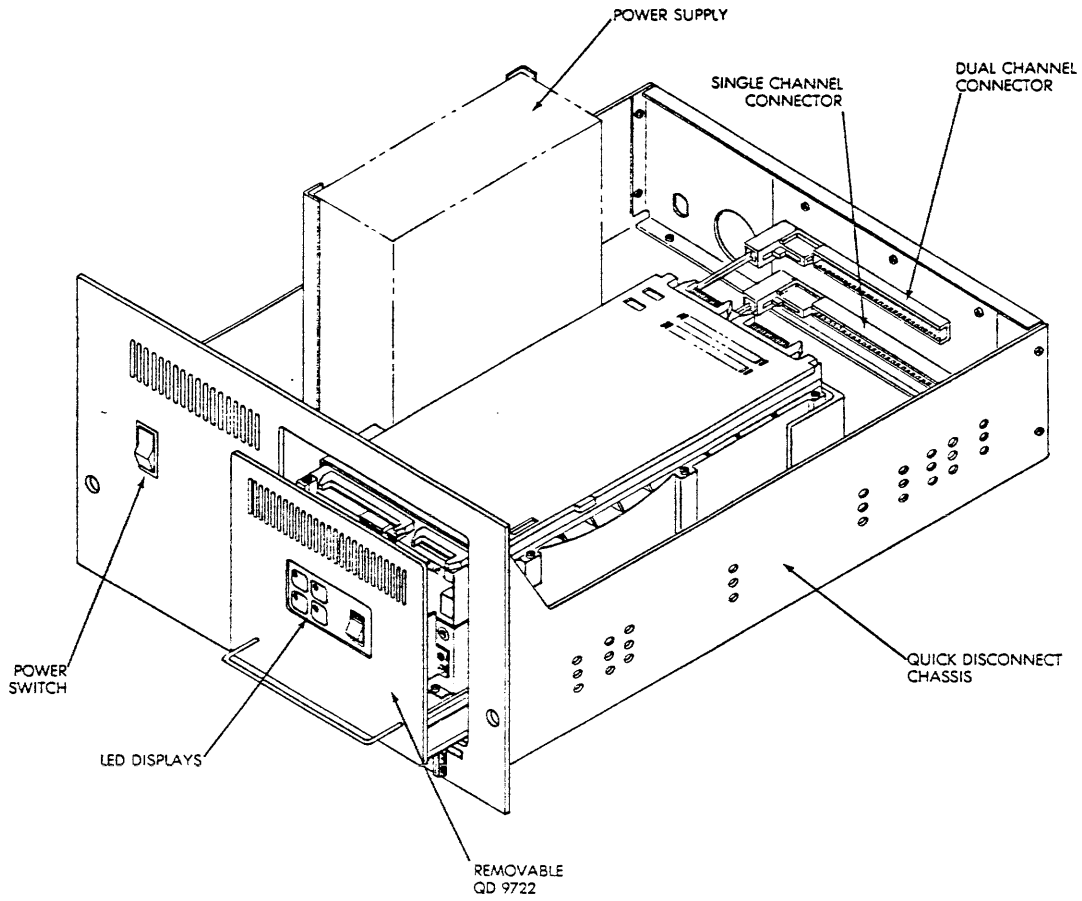

Figure D-2. Quick Disconnect (Interior View)

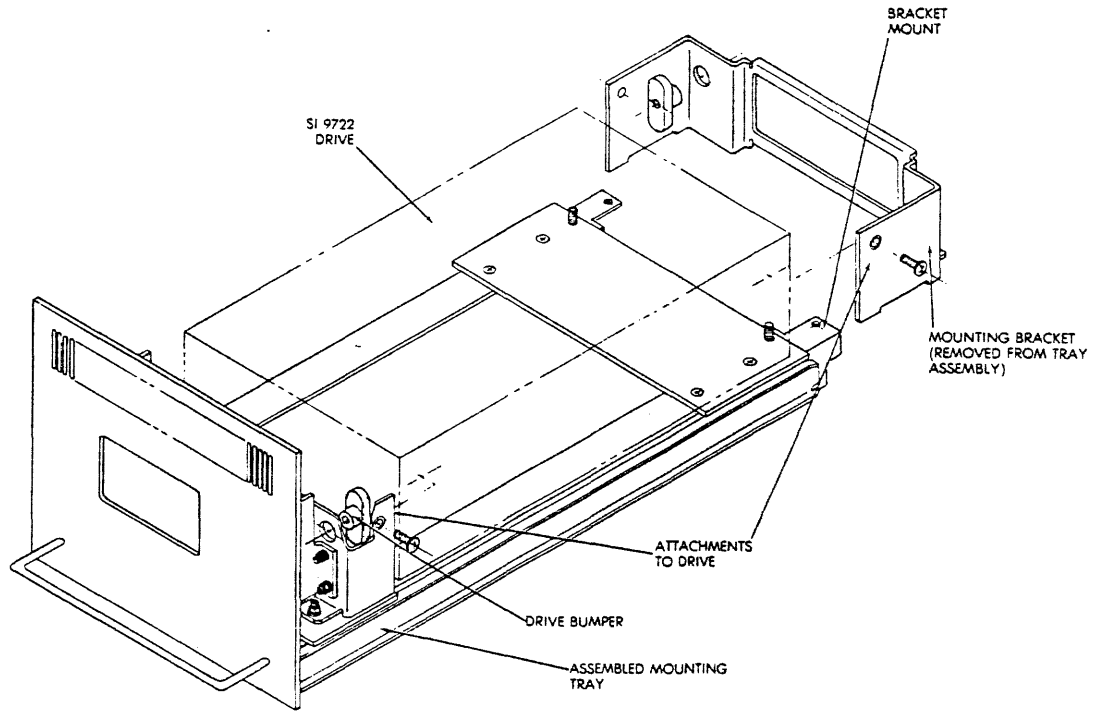

Figure D-3. Modified 9722/9733 Drive

D.2 Cabling

At the rear of the chassis are two pairs of A- and B-cable connectors for interfacing the drive with the controller, or controllers in dual channel mode, and a socket for the drive power cord. The lower pair of connectors are for single channel operation. Removing a drive or inserting another modified drive into the chassis does not affect the system, because the controller is connected to the chassis and not directly to the drive.

D.3 Drive Modification

The SI 9722/33 drive has been factory modified to adapt to the QD chassis. The procedures for configuring the modified drive are the same as for a standard drive. Dual port option is also available for both modified drive models, but the installation procedure (Paragraph D.6) is different from that described in the Disk Drive User's Guide.

D.4 9722/33 Quick Disconnect Installation

This paragraph details the procedures for retrofitting a standard system with the QD system in an SI 42-or 60-inch FCC-compliant cabinet.

NOTE

There must be at least 10.5 inches (26.7 cm) of vertical rack space available.

The installation kit contains the following:

- QD chassis assembly containing
 - Power supply
 - Power cable
 - Backplane
 - A- and B-cable headers
 - Drive extractor (locking arm)
- Factory modified 9722 or 9733 drive which includes
 - Front panel with handle
 - Rear mounting bracket and bracket mounts
 - Rear handle
 - Mounting tray

The installation procedure is as follows:

1. Shut off the power switch on the power distribution box in the cabinet.
2. Slide the QD chassis assembly into the 10.5-inch (26.7 cm) space in the cabinet. (This vertical space should already have been made available.)
3. Run a 60-conductor A-cable and a 26-conductor B-cable from the lower set of A- and B-connectors at the rear of the QD to the appropriate controller.
4. Make the appropriate settings on the power supply unit. (See the Disk Drive User's Guide.)

5. Connect the DC power supply cord to the plug at the rear of the chassis. Connect the AC power cord to the power distribution strip in the cabinet.
6. Check the locking arm to make sure it moves easily from side to side and that the connectors on the backplane open and close properly.

This completes the QD chassis installation.

D.5 Insertion and Removal of the Modified 9722/9733

This paragraph describes the procedure for inserting and removing the drive from the chassis. The procedure will also have to be made available to site personnel that will be using the QD system.

The procedure for installing the drive is as follows:

1. Before inserting the drive make certain that the locking arm is all the way to the right (the OPEN position). Failure to do this can result in damage to the connectors and the backplane.
2. Grasp the drive by the front and rear handles, making sure that the drive is level, and set it on the chassis rails. Move it slowly toward the rear of the chassis until it just touches the backplane.

WARNING

Do not attempt to force the drive into the backplane.

3. Move the locking arm all the way to the left (CLOSED position). This seats the drive in the backplane connector slots.
4. If the drive has been correctly configured, power it up.

The removal procedure is as follows:

1. Power down the drive.

WARNING

Wait at least 60 seconds for the drive to spin down completely.

2. After the drive has spun down, slide the locking arm all the way to the right (OPEN position). This disconnects the drive from the backplane.
3. Pull the drive forward on the chassis rails until the rear handle can be reached.
4. Using the front and rear handles remove the drive.

CAUTION

Personal injury and/or equipment damage could result if care is not taken when removing the drive. The modified drive weighs about forty pounds. Be sure that it is properly supported as it is withdrawn from the chassis.

D.6 Dual Channel Option Installation

The 9722/9733 dual channel kit contains the following:

- Dual channel option board
- Adapter board frame
- Mounting hardware
- Five cable assemblies

The installation procedure is as follows:

1. Power down the drive.

CAUTION

Wait 60 seconds for the drive to spin down.

2. After the drive has spun down, move the locking arm of the quick disconnect chassis all the way to the right to release the drive from the backplane.
3. Pull the drive forward far enough to expose the rear fold-down handle.

CAUTION

The modified 9722/9733 quick disconnect drive weighs about 40 pounds.

4. Grasp the front and rear handles and slide the drive out of the chassis.
5. Put it in a convenient work space to do the dual channel installation.
6. Remove the dual channel PCB cover plate. It is held in place by two screws at the end of the board where the five cables are attached.

NOTE

The cables might have been packed separately, in which case they will have to be mounted on the dual channel PCB as shown in Figure D-1.

CAUTION

The pins on the 14-conductor cable connectors are very fragile and bend or break easily.

7. Pass the cables under the board, keeping them correctly oriented as shown in Figure D-1. The cables should extend a few inches beyond the edge of the card.
8. Using two number six screws mount the dual option board on the cover plate of the drive interface board. Orient the board as shown in Figure D-1.

NOTE

The 9722 interface board is designated CZFM. The 9733 is designated KGFM.

9. Remove the cover plate of the CZFM/KGFM board. (At this point the cover plate from the CZFM/KGFM board and the dual channel board are attached to each other.)
10. Connect the 14-conductor interface cables from the dual channel PCB to the drive interface board. Loop the ends of the cables back to meet the headers on the interface board (Figure D-1). The dual channel PCB interface headers are designated S3, S1, S4, S2. Connect the cables to their corresponding headers on the drive interface board as follows:
 - S3 to S4 (CZFM/KGFM)
 - S1 to S2 (CZFM/KGFM)
 - S4 to S5 (CZFM/KGFM)
 - S2 to S3 (CZFM/KGFM)
11. Replace the CZFM/KGFM cover plate and tighten the screws.
12. Disconnect the B-cable from CN2 on the CZFM/KGFM board and reconnect it to CN23 on the dual channel board. This is the channel 1 B-cable.
13. Run the B-cable from CN24 on the dual channel board to CN2 on the CZFM/KGFM board.
14. Run the power cord from CN25 on the dual channel board to CN33 on the power supply.
15. Replace the cover plate on the dual channel board.
16. Attach A- and B-cables to the upper set of A- and B-connectors at the rear of the QD chassis and run them to the appropriate controller.
17. Reinstall the drive, making sure that the locking arm is all the way to the right before inserting the drive. Move it slowly toward the rear of the chassis until it touches the backplane. Move the locking arm all the way to the left to seat the drive in the backplane.

This completes the dual channel option installation procedure.

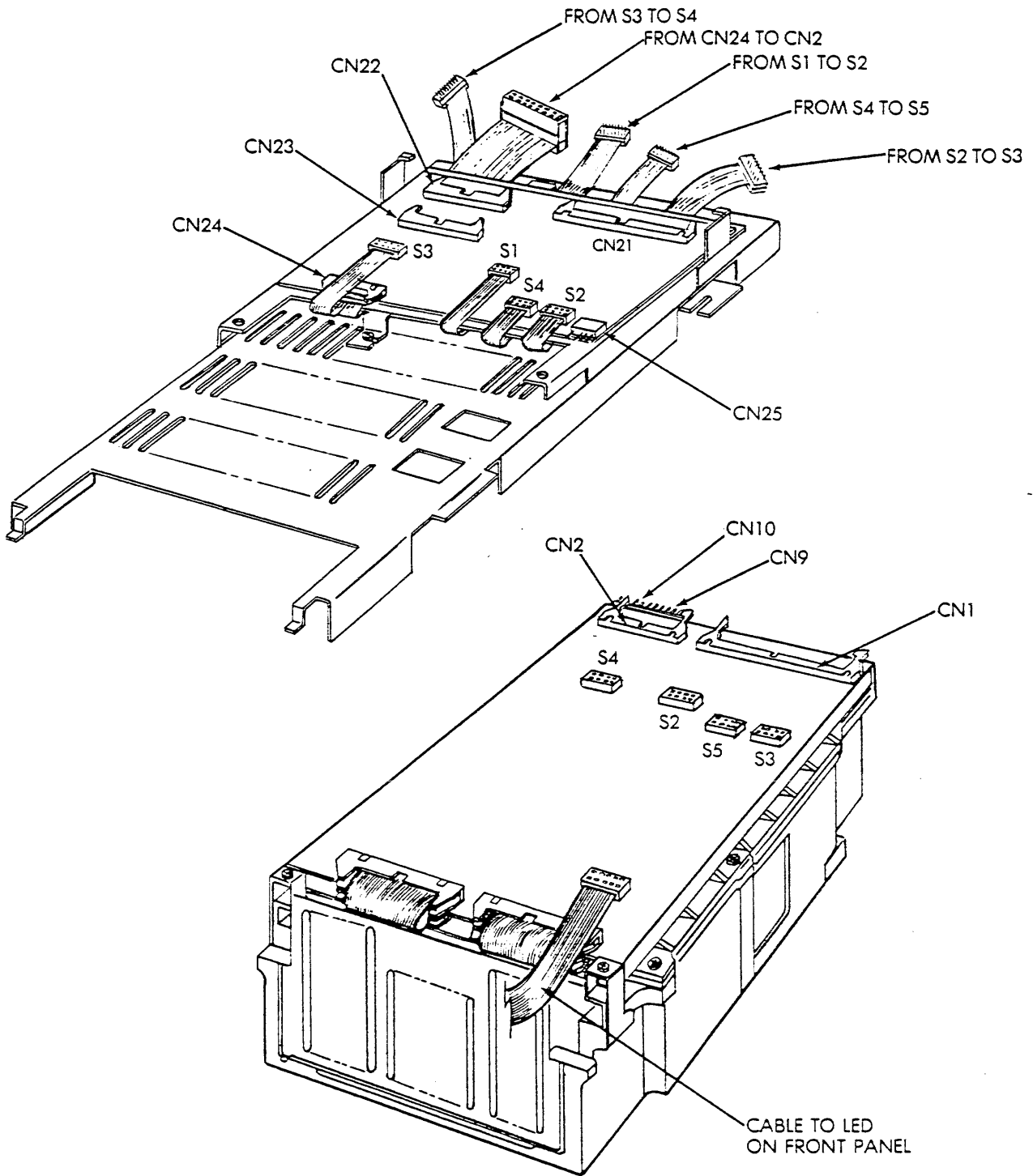

Figure D-4. Dual Channel Option Installation

